



(19) **United States**

(12) **Patent Application Publication**
Matsumura et al.

(10) **Pub. No.: US 2002/0107453 A1**

(43) **Pub. Date: Aug. 8, 2002**

(54) **BIOLOGICAL SIGNAL TRANSMISSION APPARATUS**

(30) **Foreign Application Priority Data**

(75) Inventors: **Fumiyuki Matsumura**, Tokyo (JP);
Tetsushi Sekiguchi, Tokyo (JP);
Hiroshi Sakata, Tokyo (JP); **Hidehiro Hosaka**, Tokyo (JP)

Dec. 25, 1997 (JP) P. HEI. 9-358536
Dec. 26, 1997 (JP) P. HEI. 9-359933

Publication Classification

(51) **Int. Cl.⁷** **A61B 5/04**
(52) **U.S. Cl.** **600/509**

Correspondence Address:
SUGHRUE MION, PLLC
2100 Pennsylvania Avenue, NW
Washington, DC 20037-3213 (US)

(57) **ABSTRACT**

(73) Assignee: **NIHON KOHDEN CORPORATION**

(21) Appl. No.: **10/113,558**

(22) Filed: **Apr. 2, 2002**

Related U.S. Application Data

(62) Division of application No. 09/657,630, filed on Sep. 8, 2000, now Pat. No. 6,389,309, which is a division of application No. 09/220,751, filed on Dec. 28, 1998, now Pat. No. 6,161,036.

An electrode **4** for detecting a biological signal and a loop antenna **3** are integrally mounted on a support **2** placed on the surface of a living body and a transmitter **5** is placed on the support **2**. A biological signal detected on the electrode **4** is input through a connector **11** to electric circuitry **10** of the transmitter **5** and an electric signal processed by the electric circuitry **10** is output through connectors **12** and **13** to both ends of the loop antenna **3** from which the biological signal is emitted to a receiver. At this time, the opening face of the loop antenna **3** is in a direction almost perpendicular to the surface of a living body for improving sensitivity.

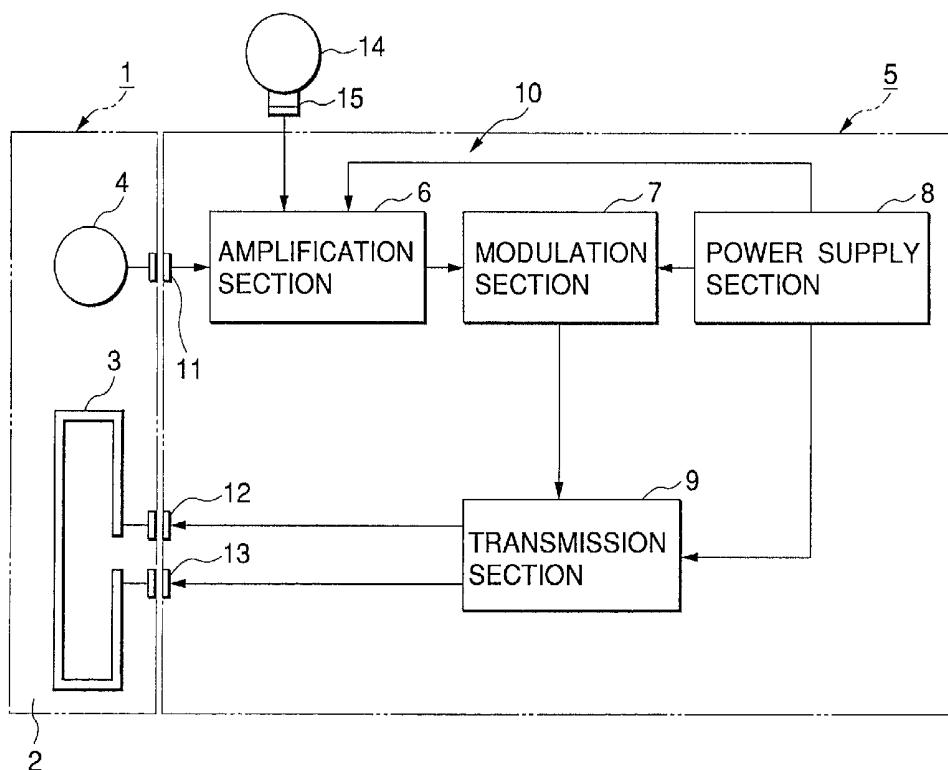

FIG.1

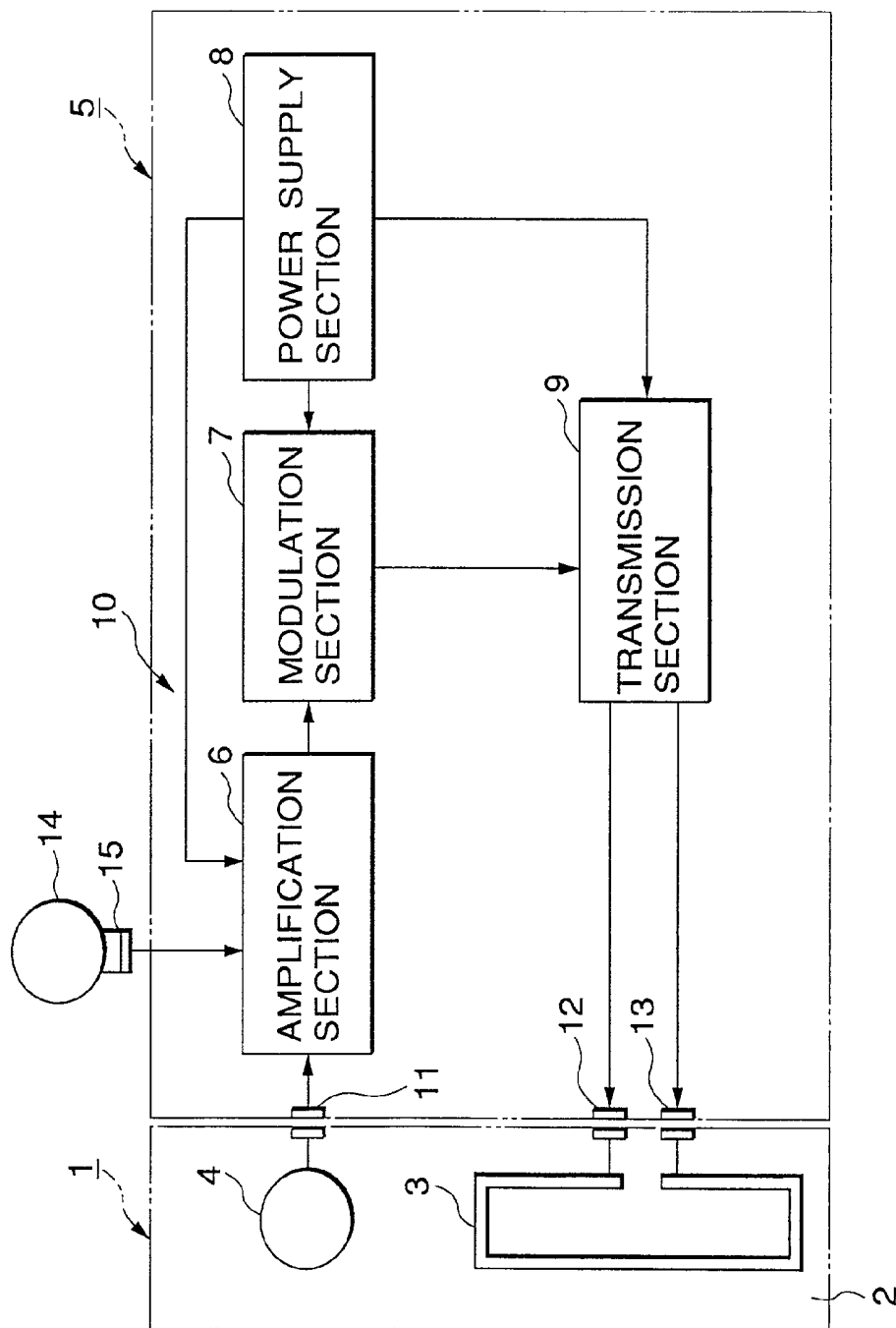

FIG.2

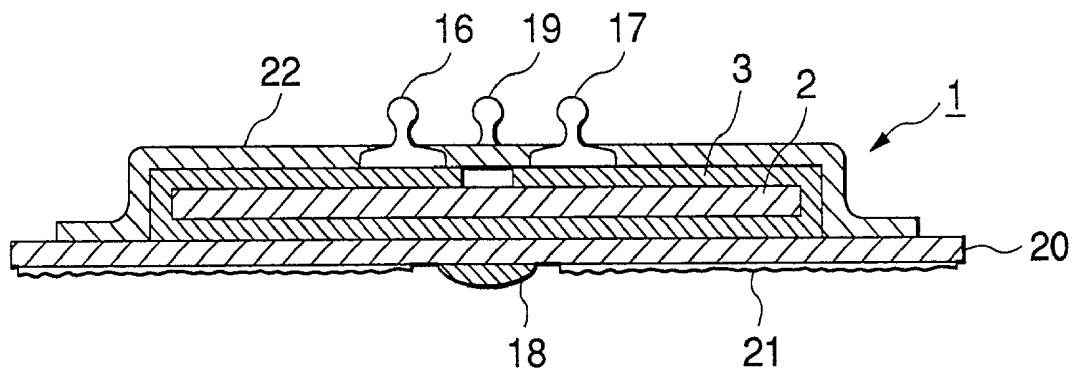

FIG.3

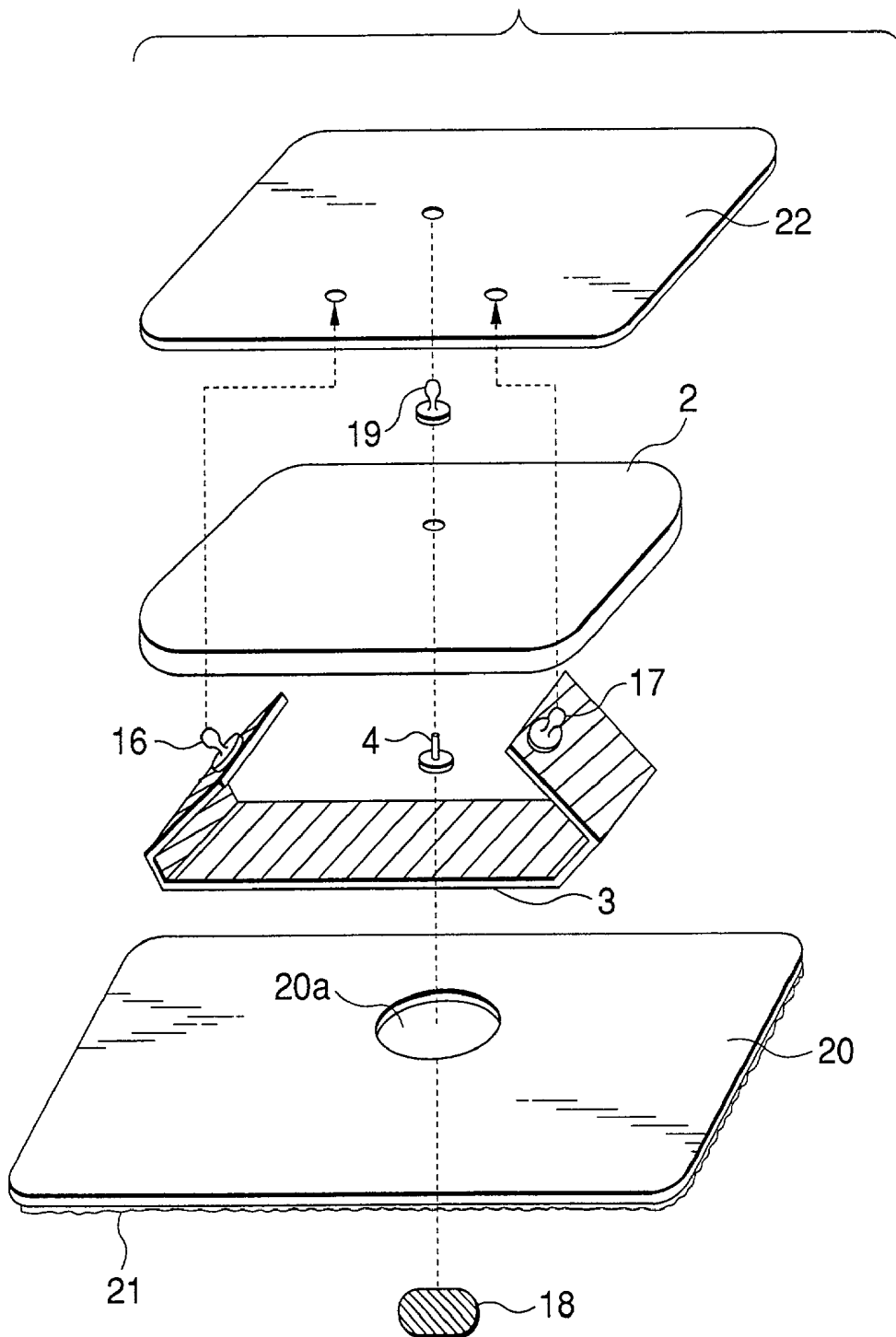

FIG. 4

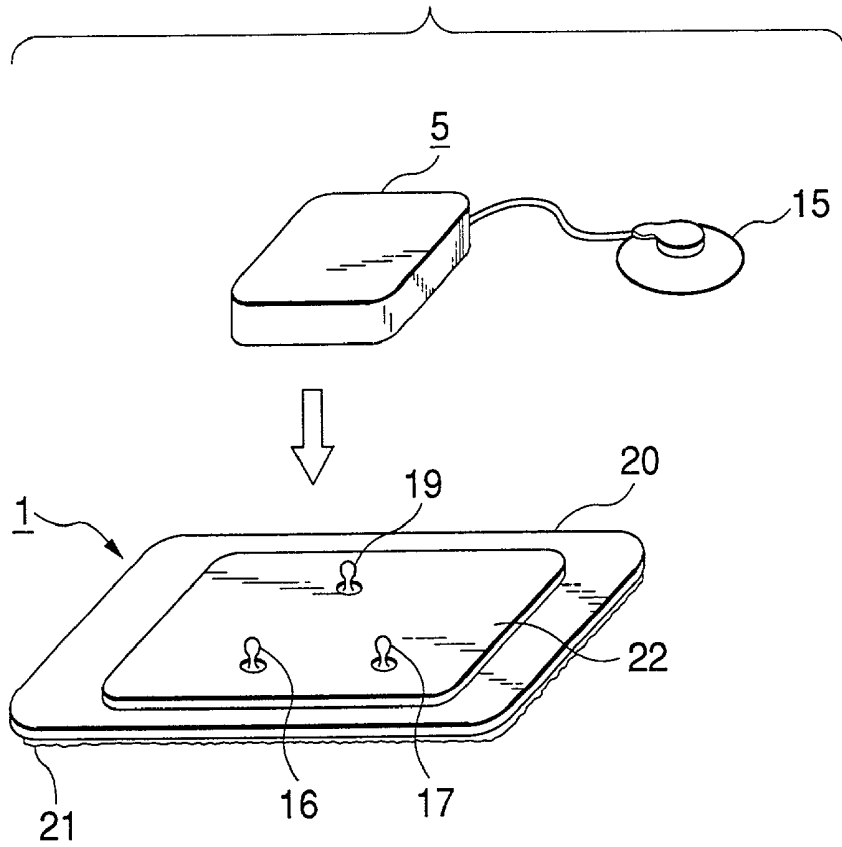

FIG.5

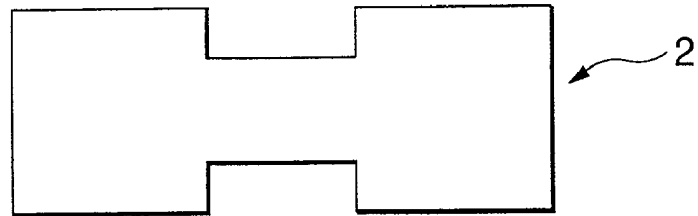

FIG.6



FIG.7

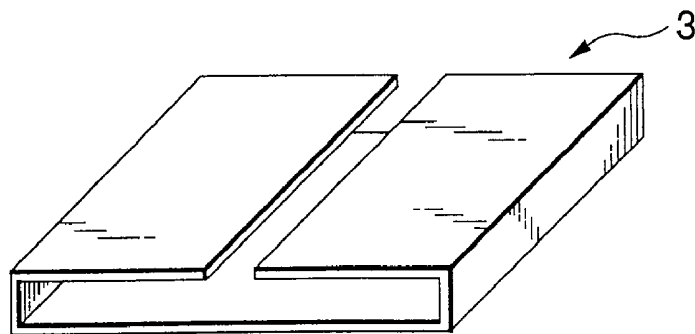

FIG. 8

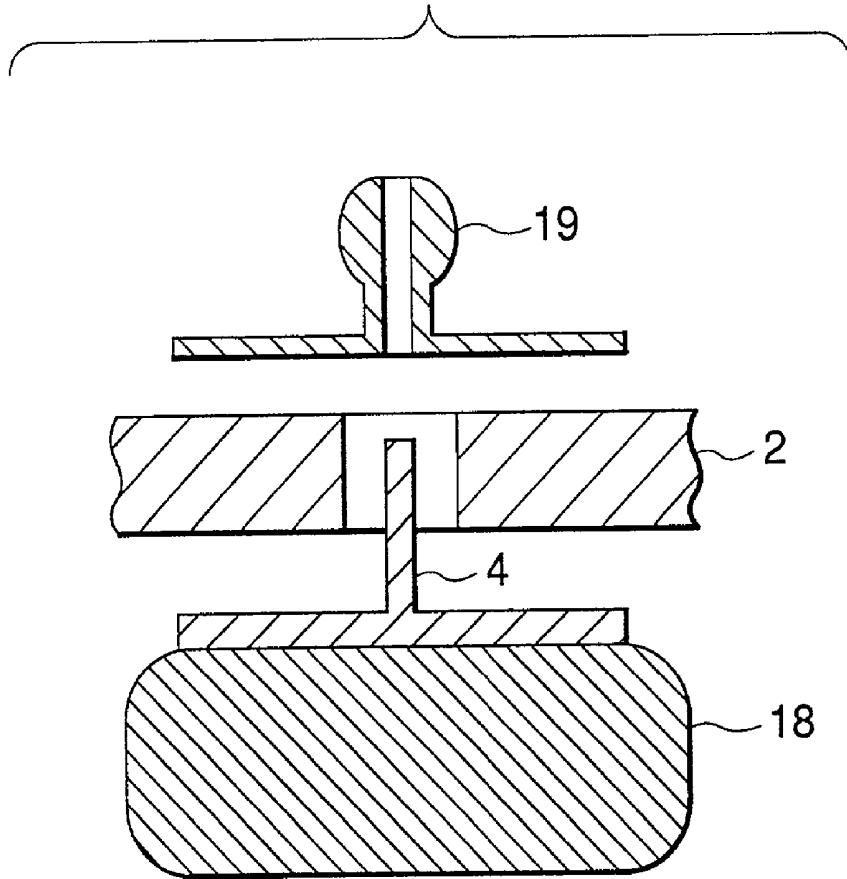

FIG.9

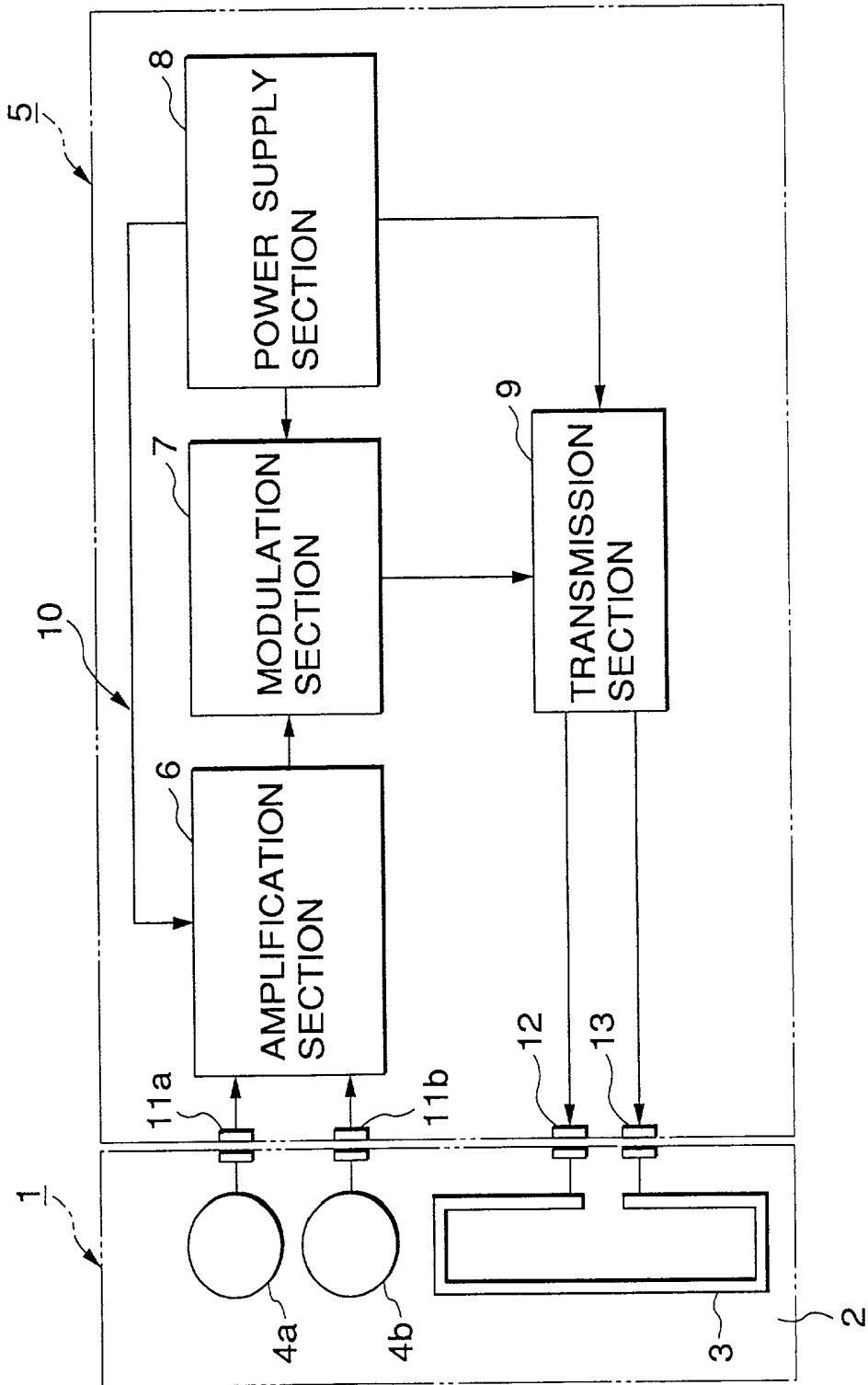

FIG.10

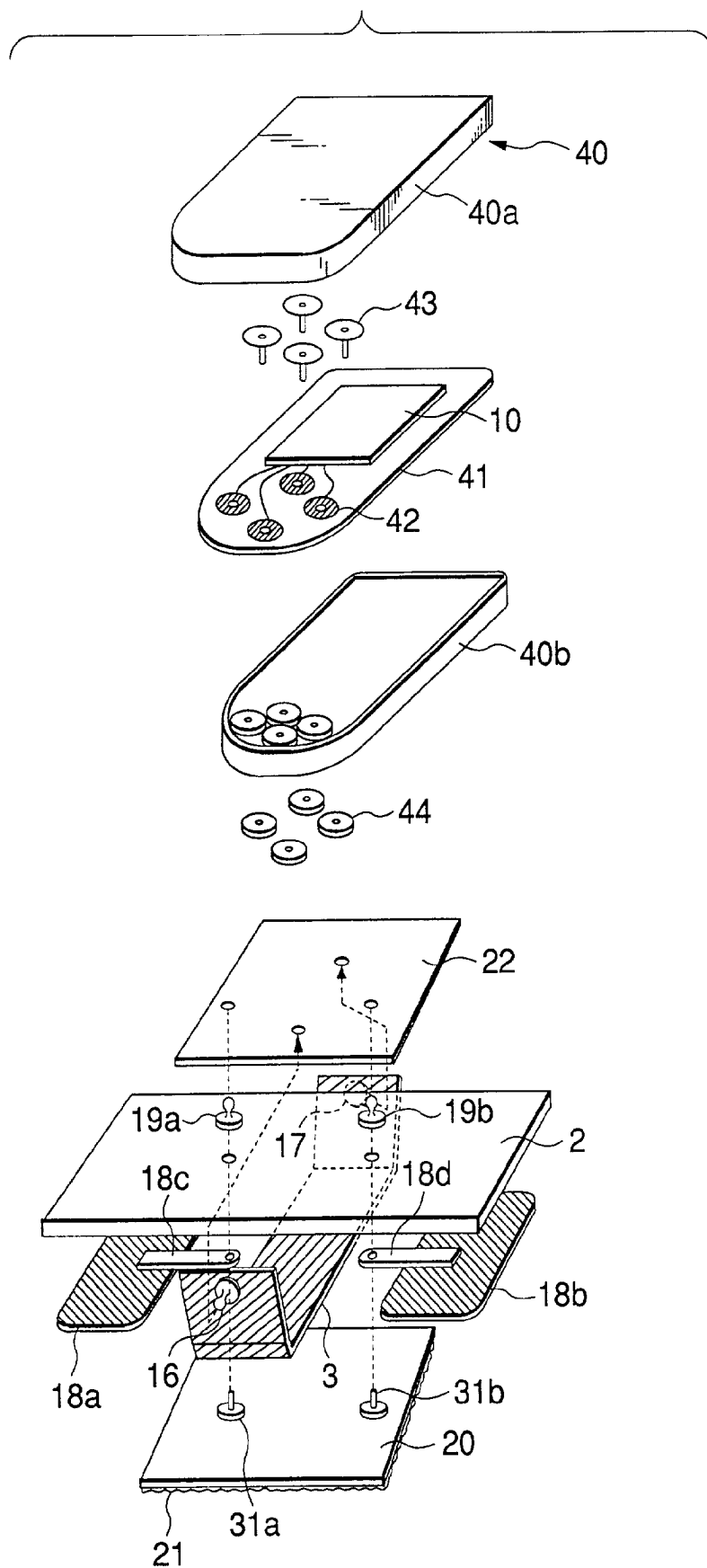

FIG.11

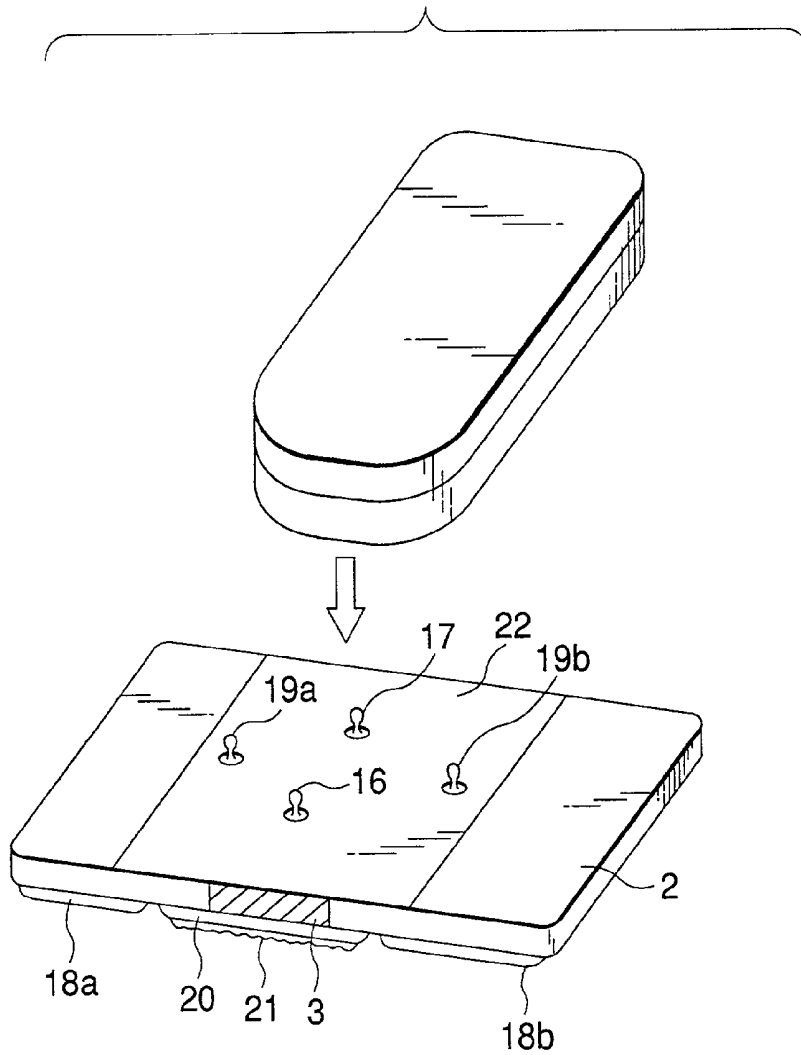

FIG.12

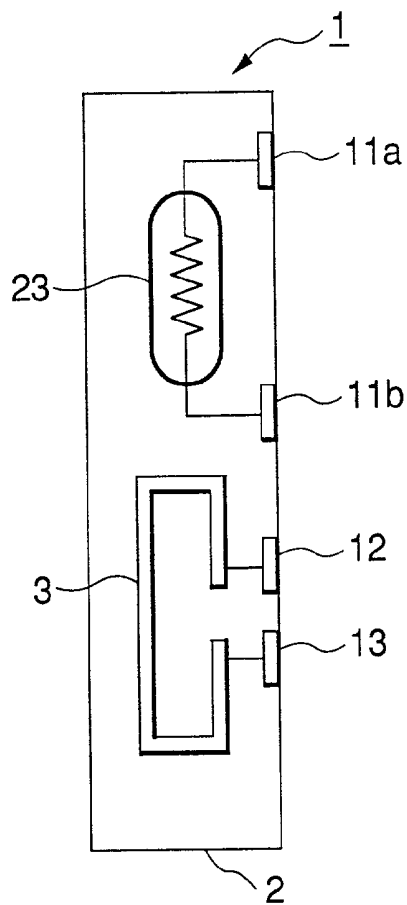

FIG.13

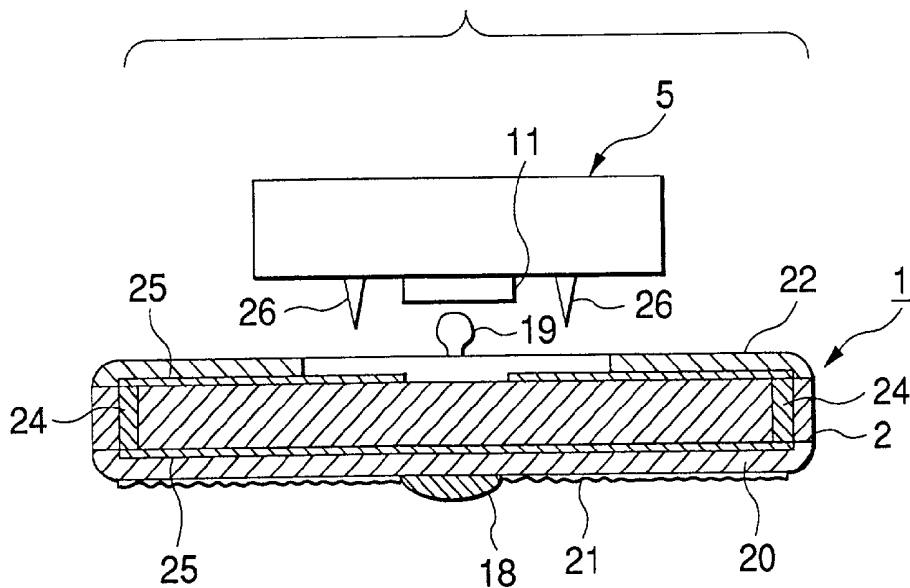

FIG. 14

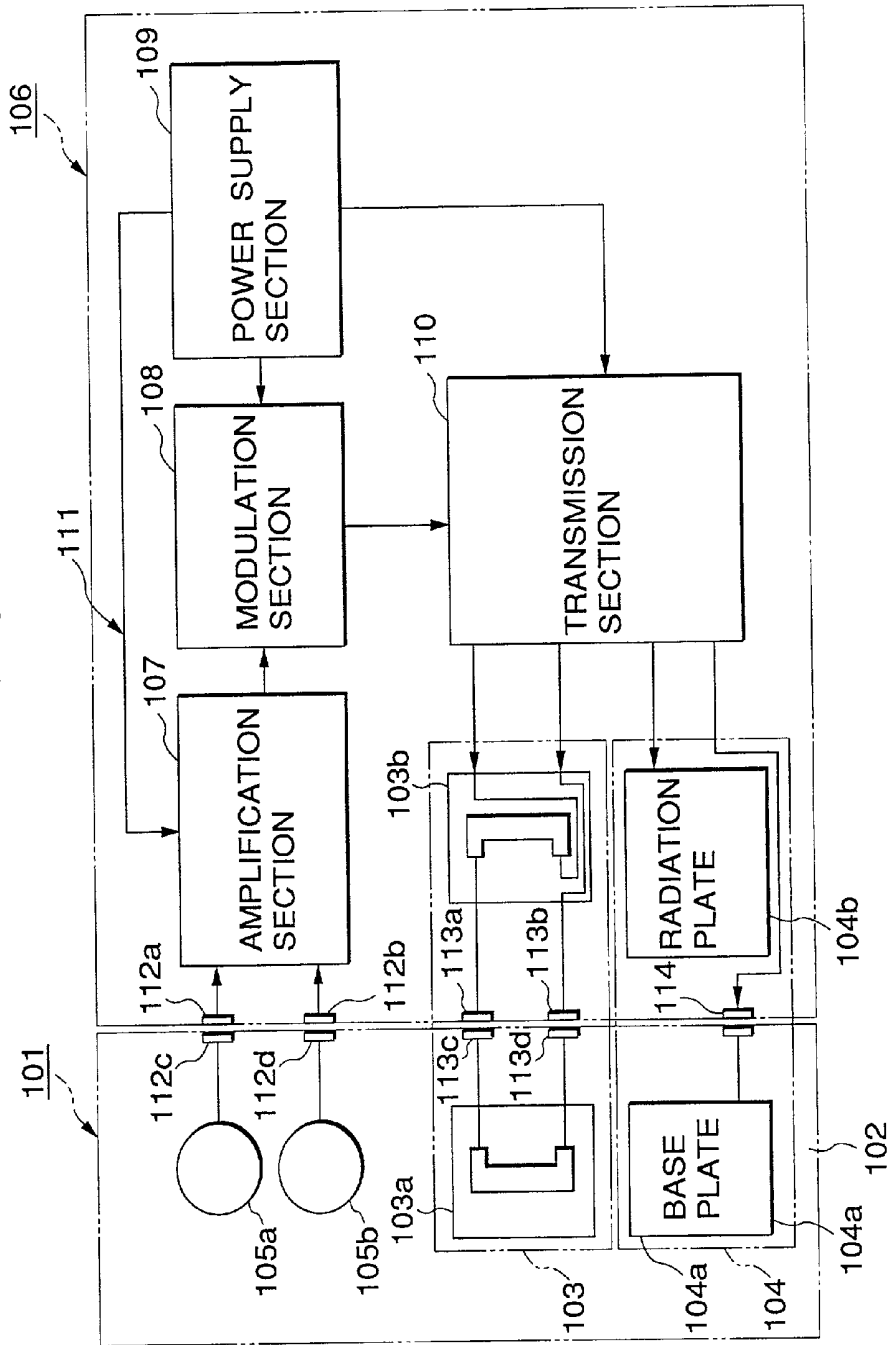

FIG. 15

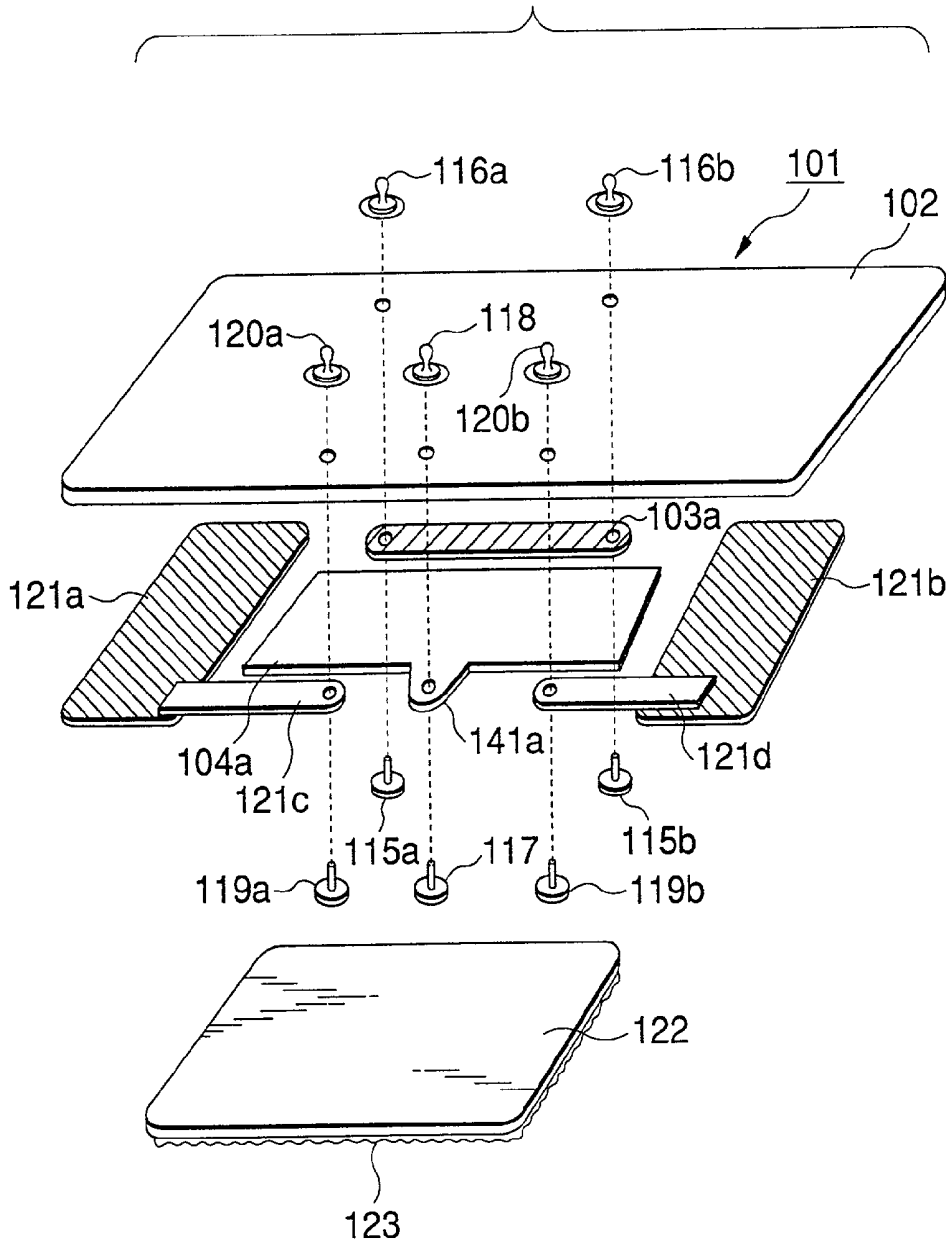

FIG.16

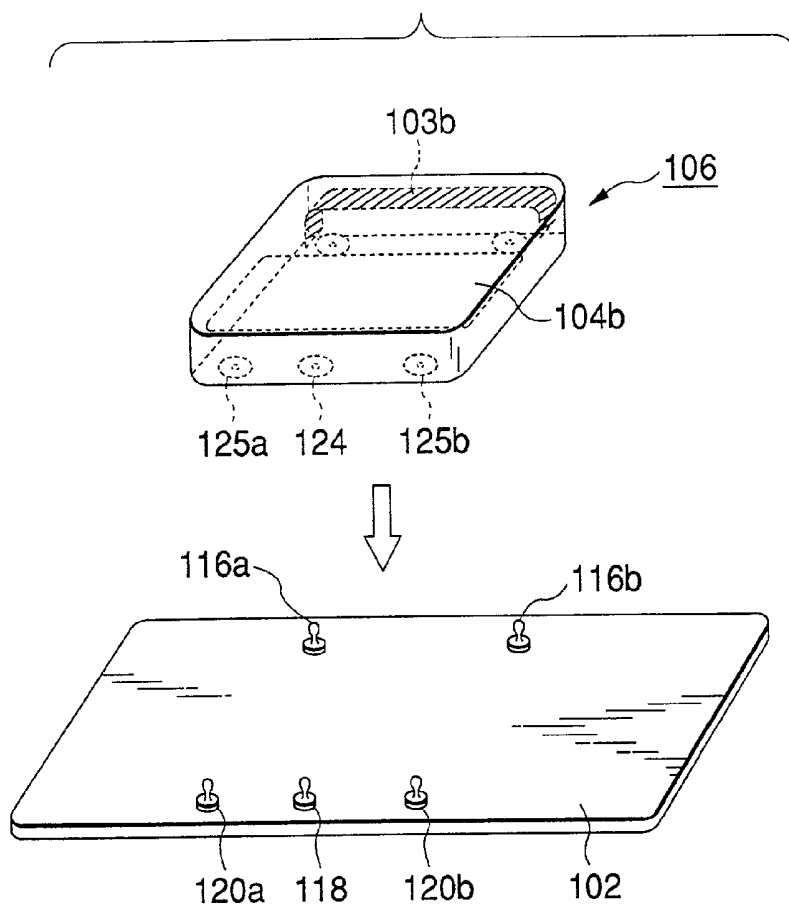

FIG.17

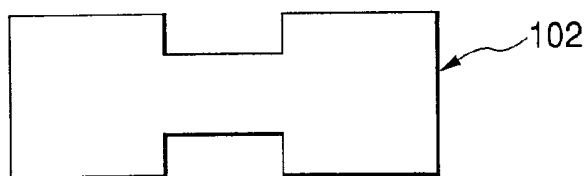

FIG.18

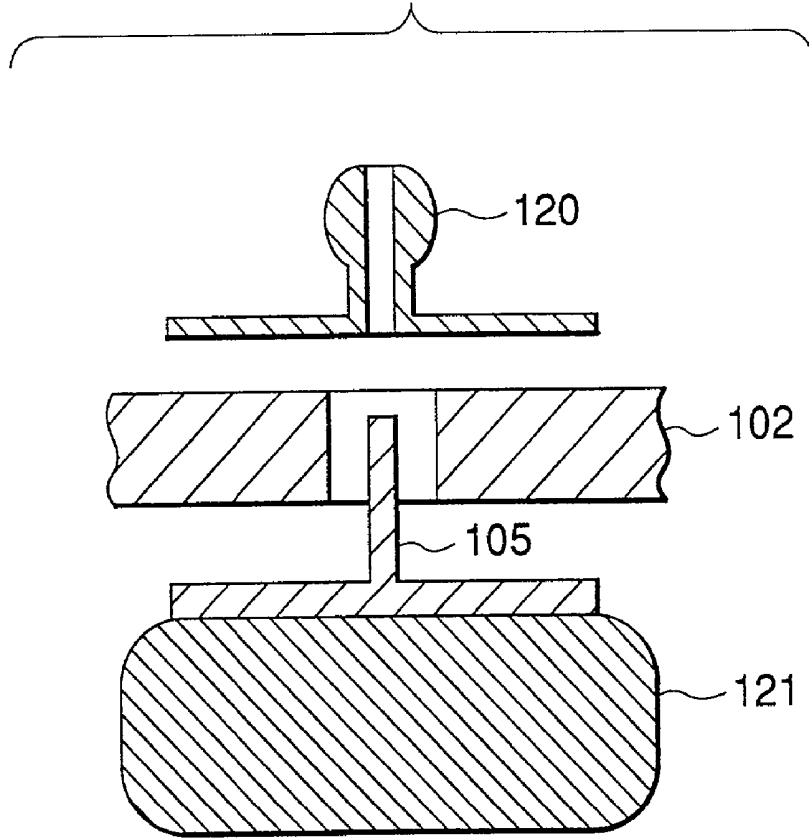

FIG.19

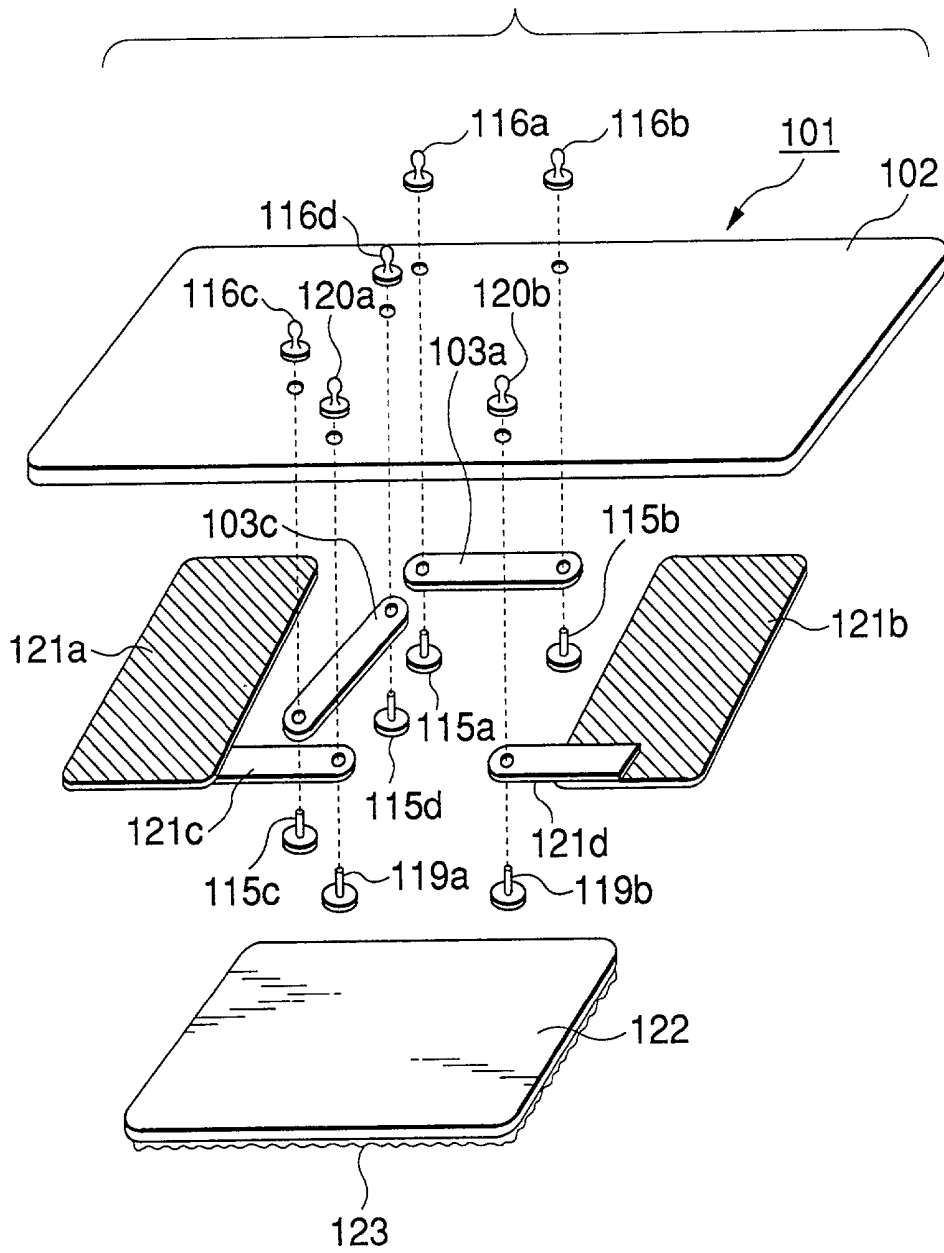

FIG.20

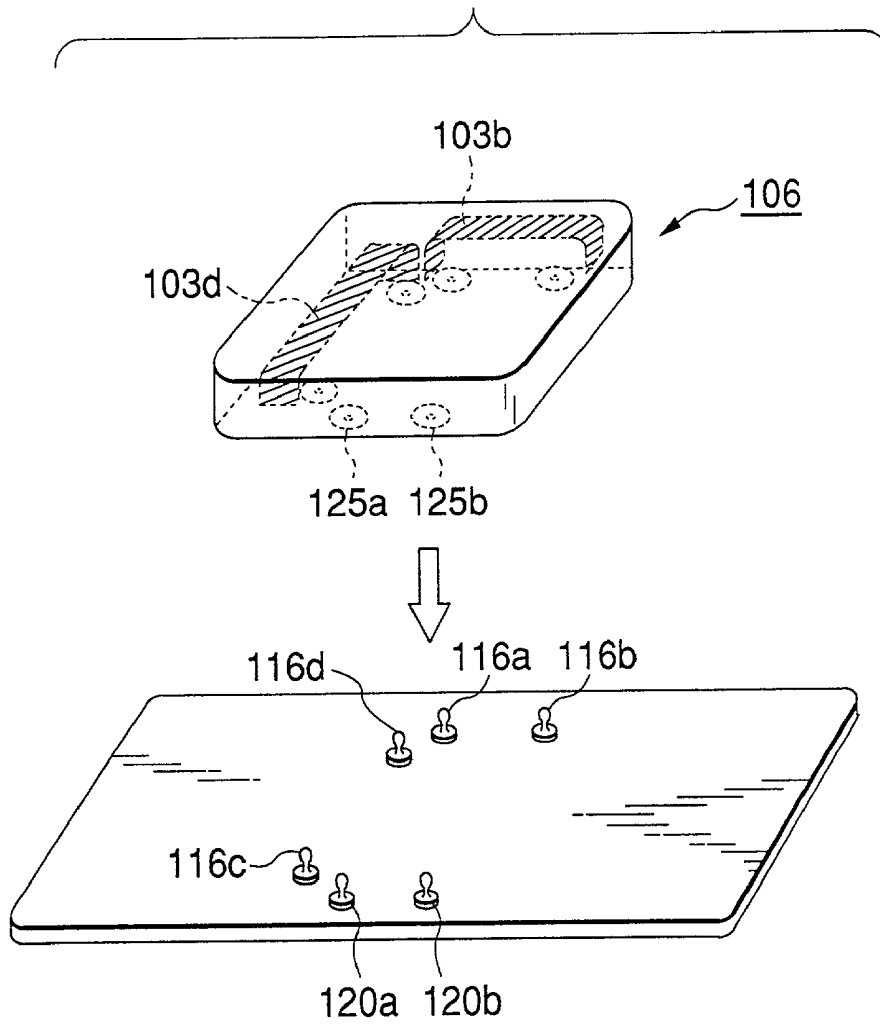

FIG. 21

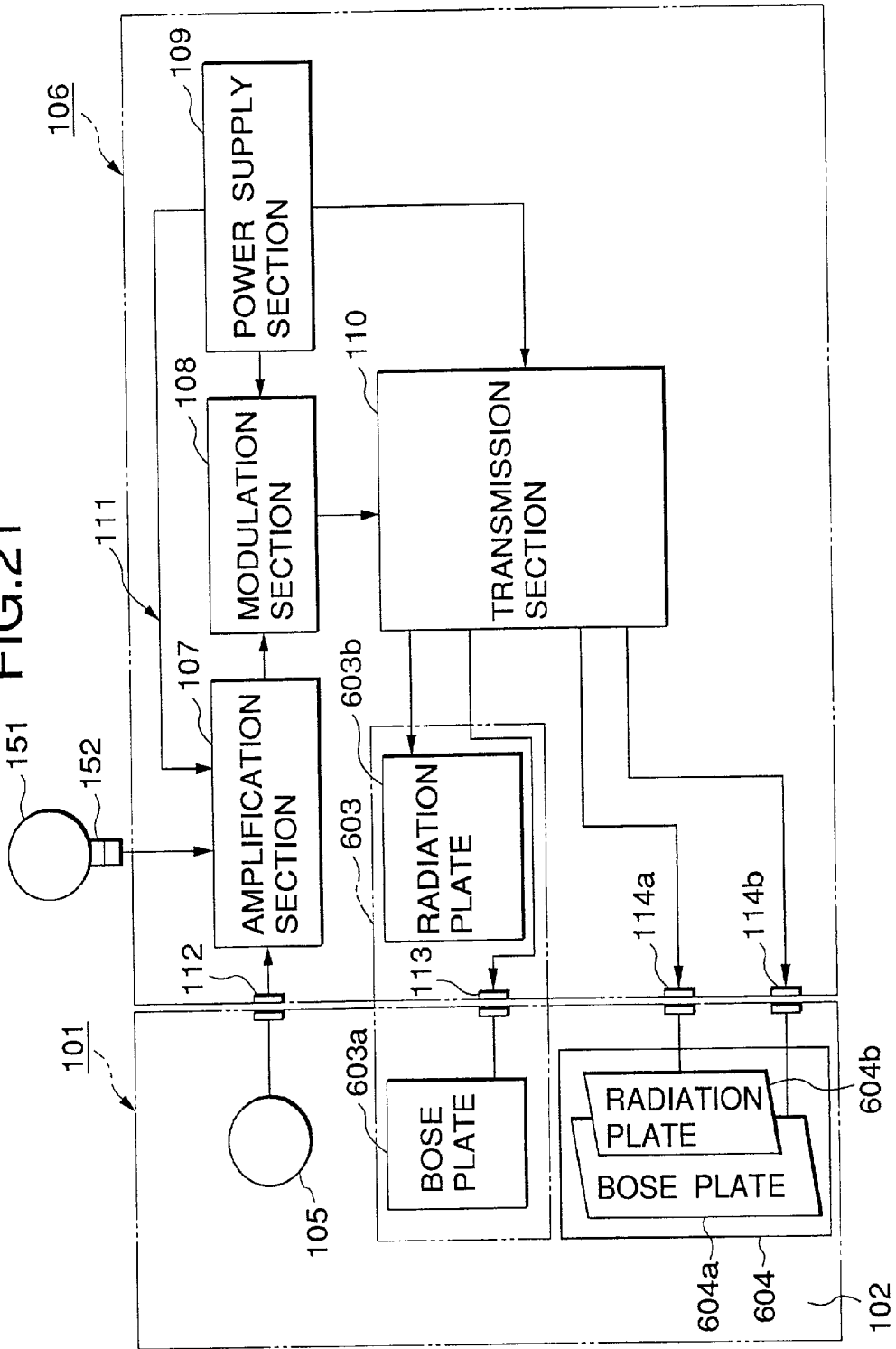

FIG.22

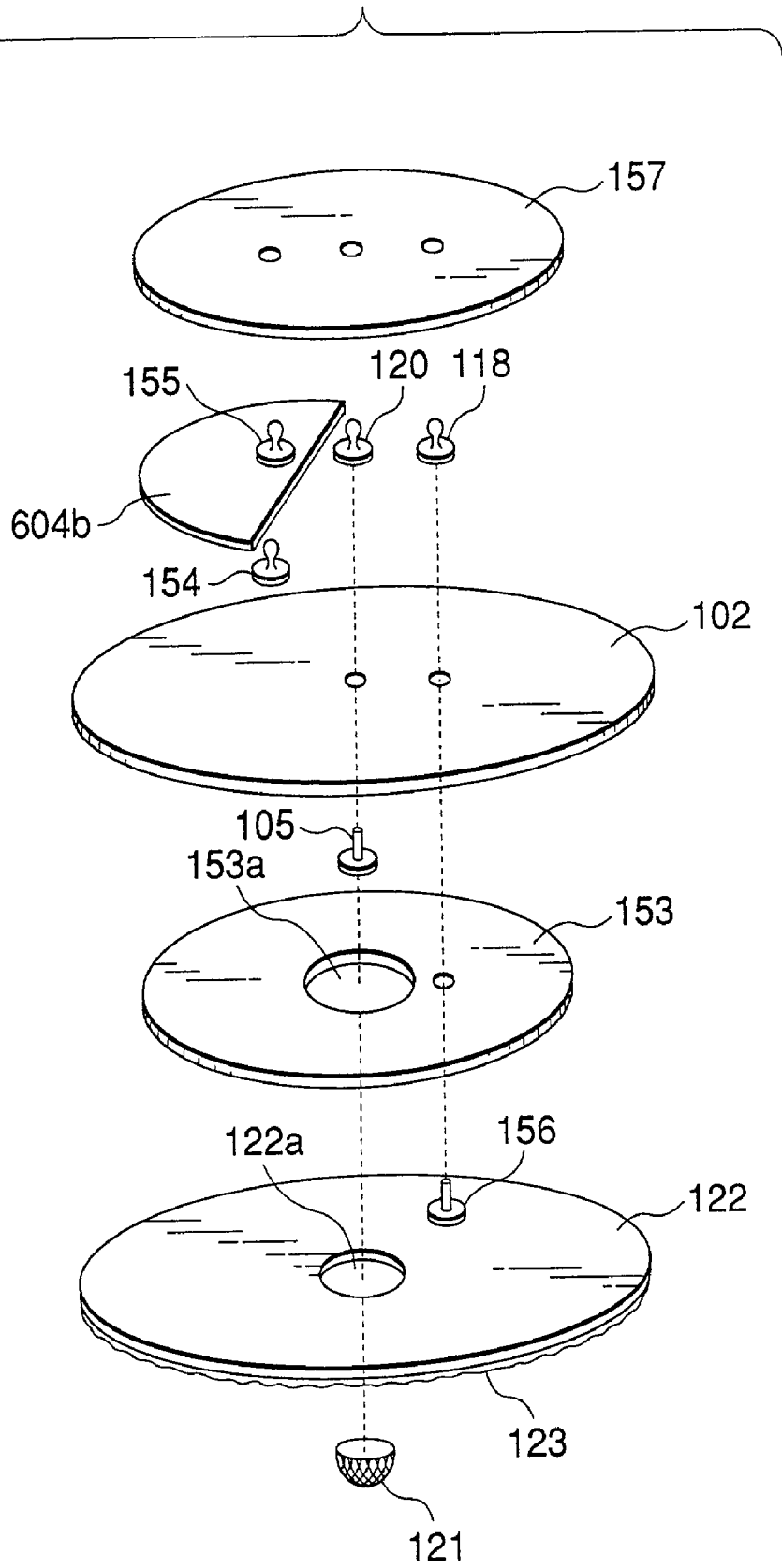

FIG.23

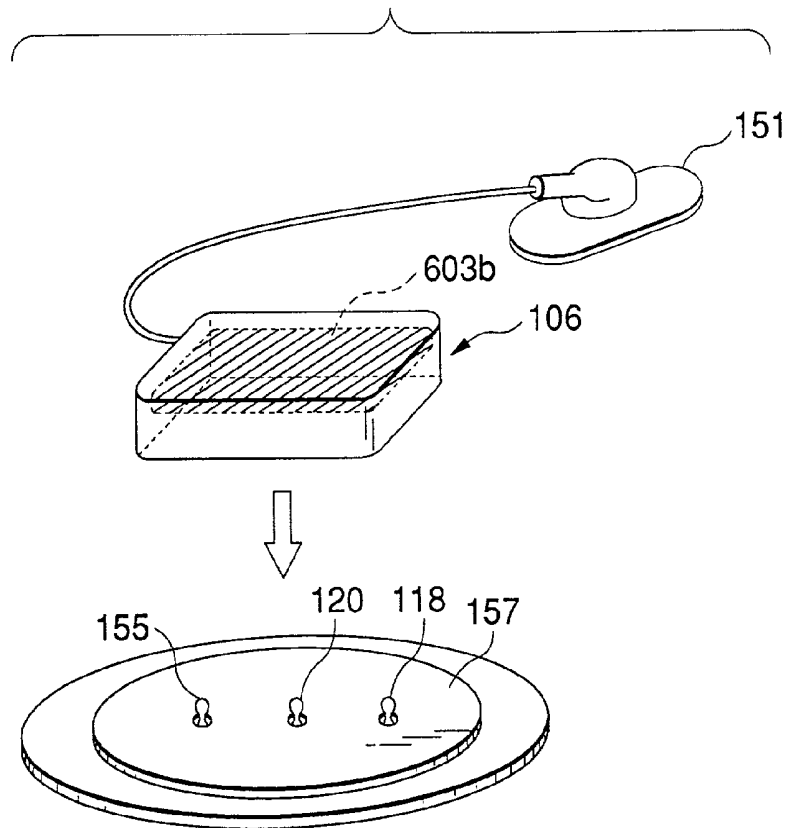

FIG.24

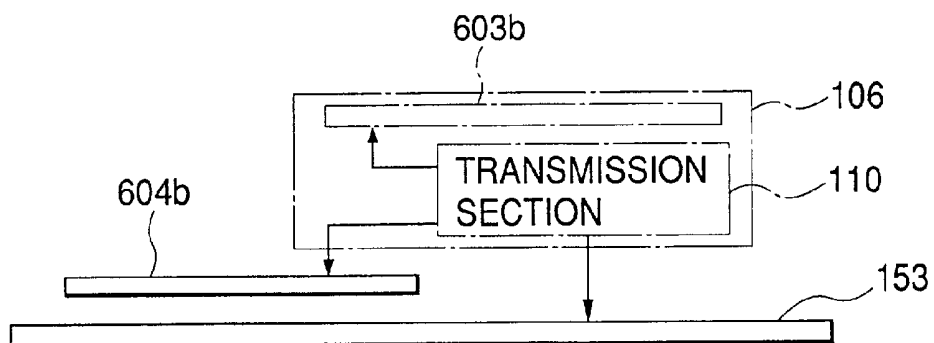

FIG. 25

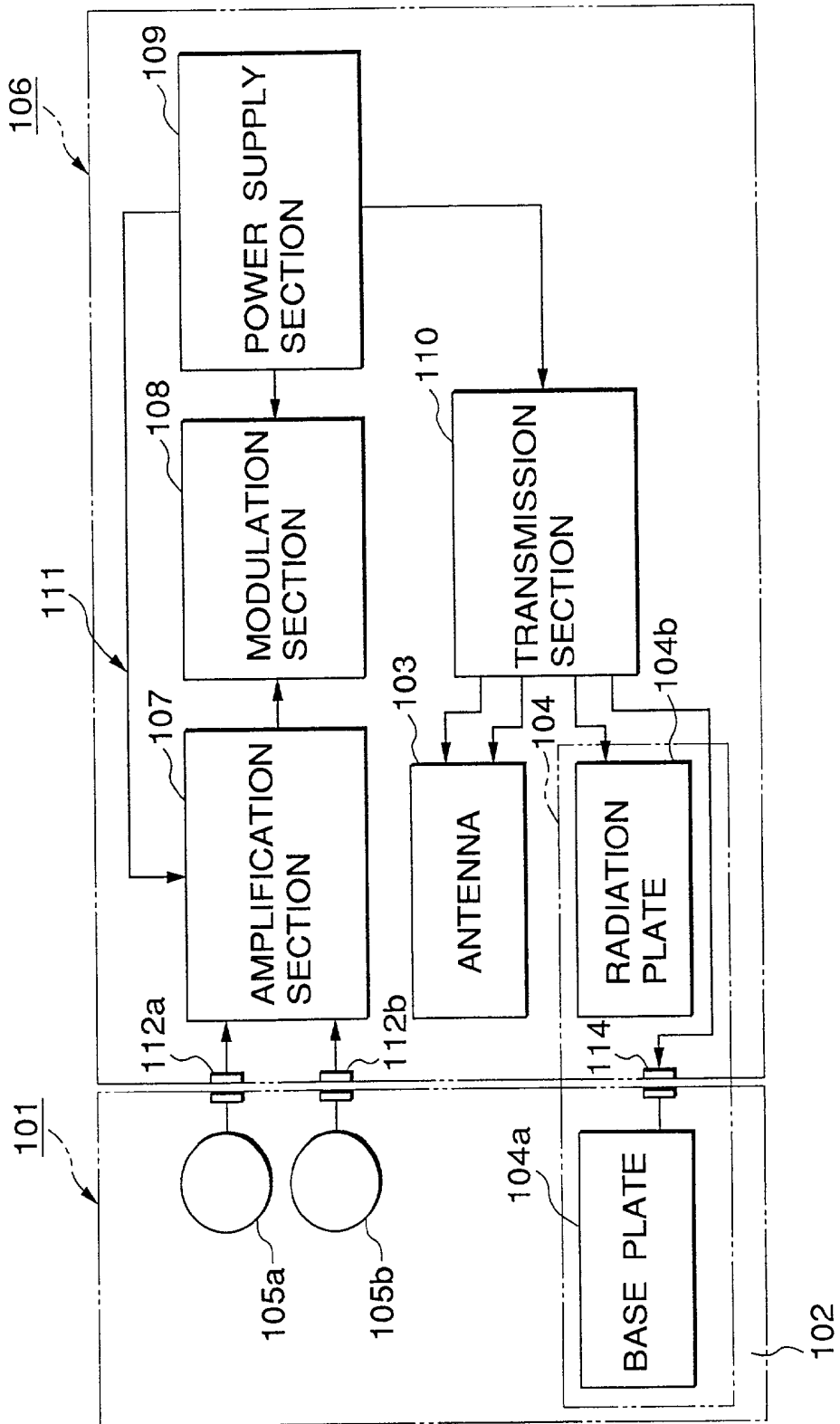

FIG.26

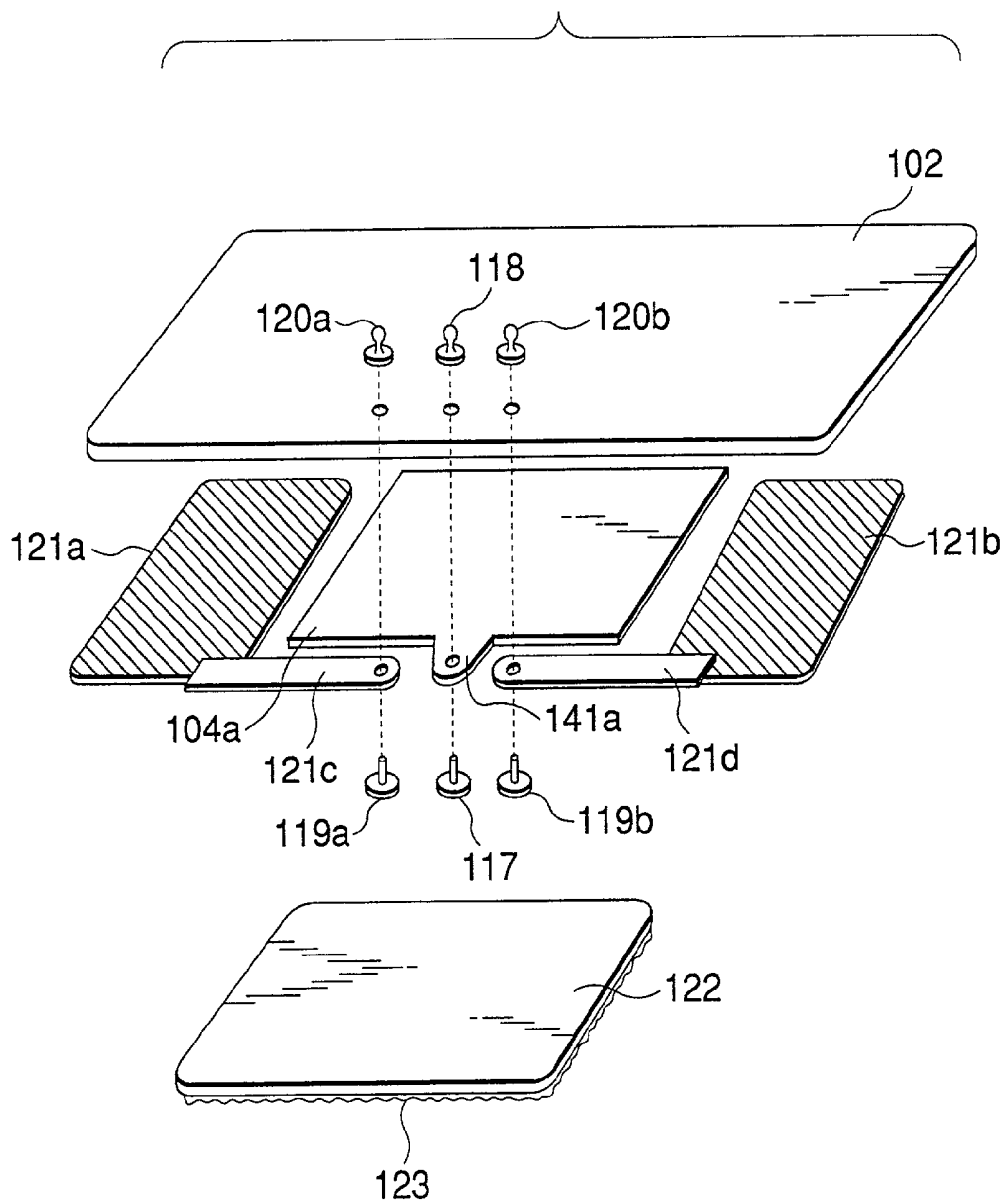

FIG.27

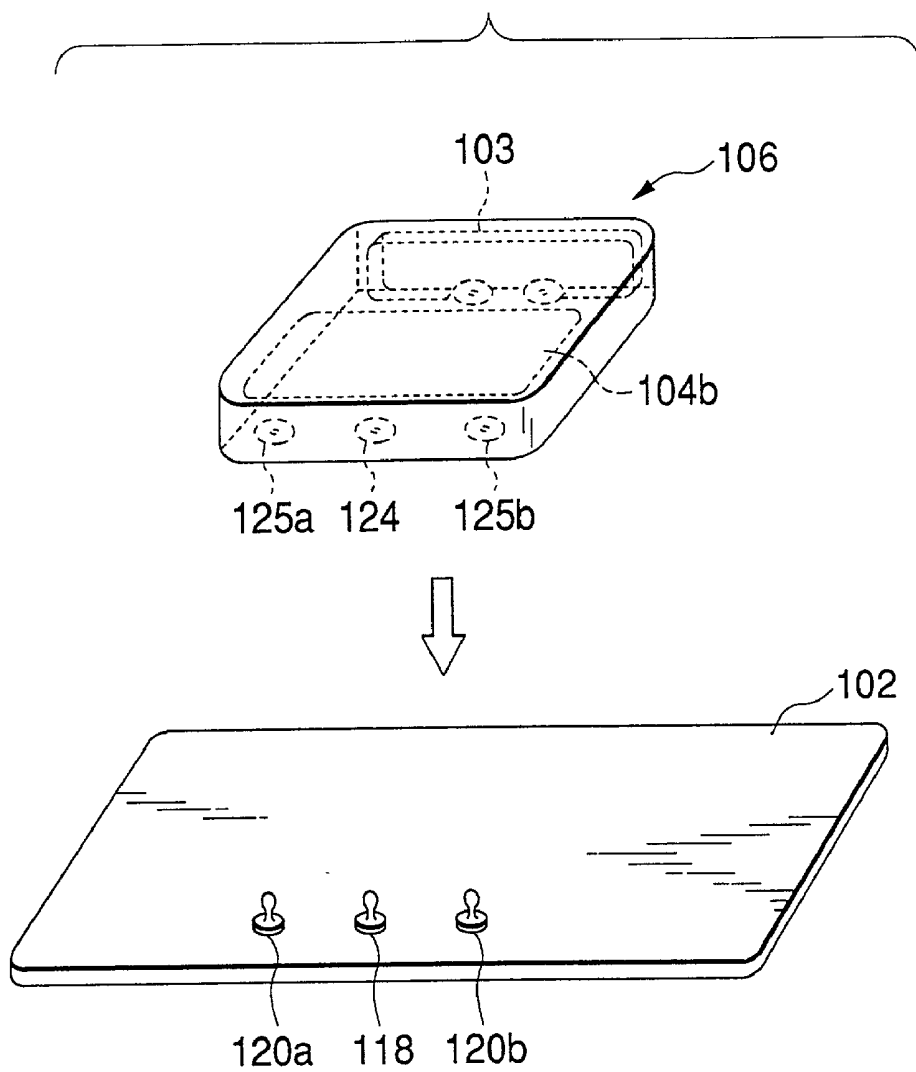

FIG. 28

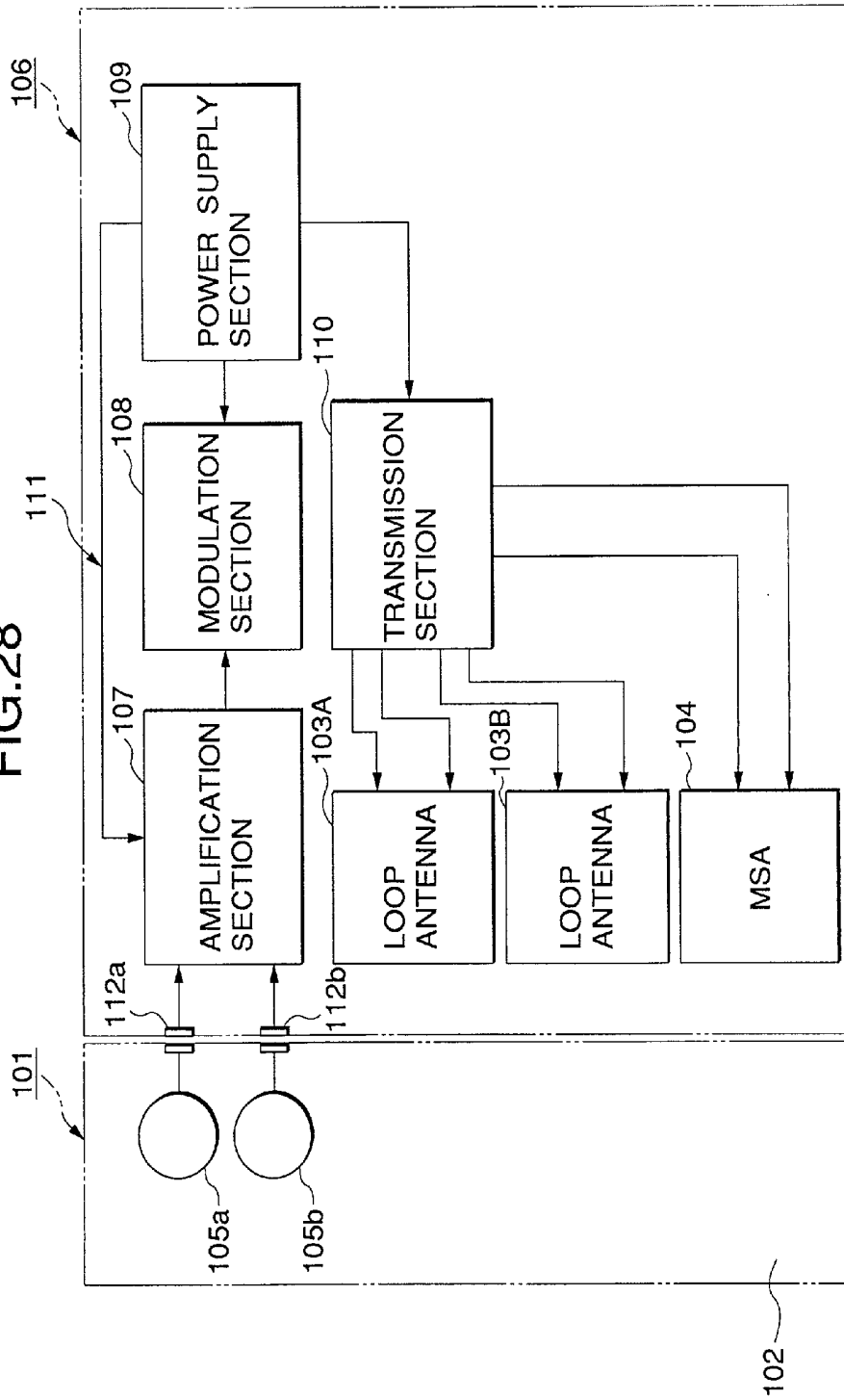

FIG.29

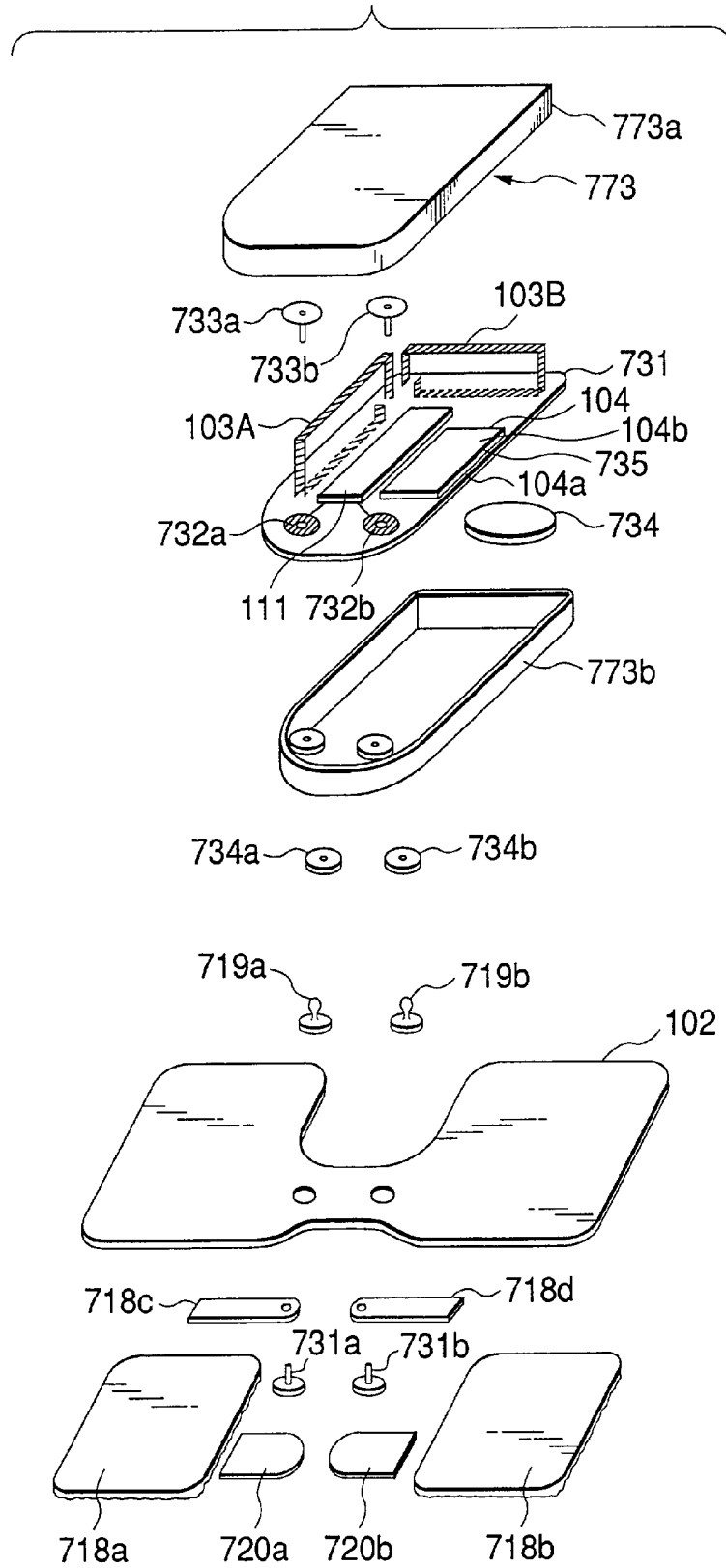

FIG.30

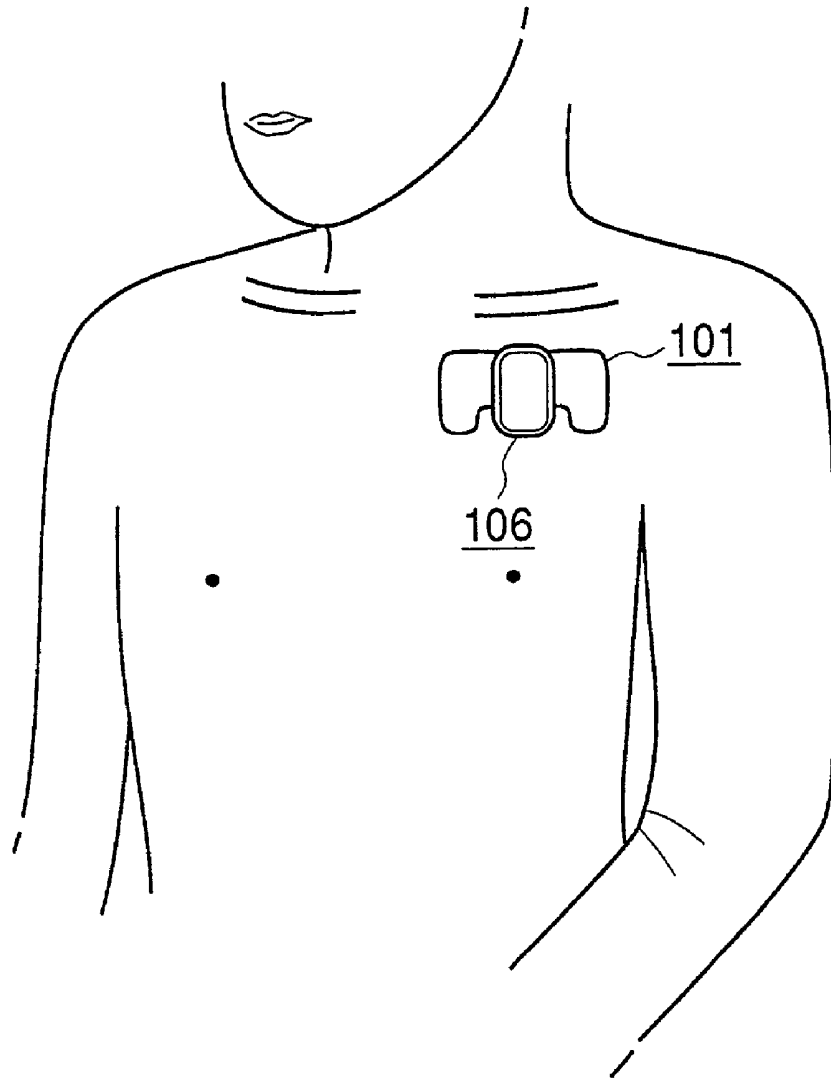

FIG.31(a)

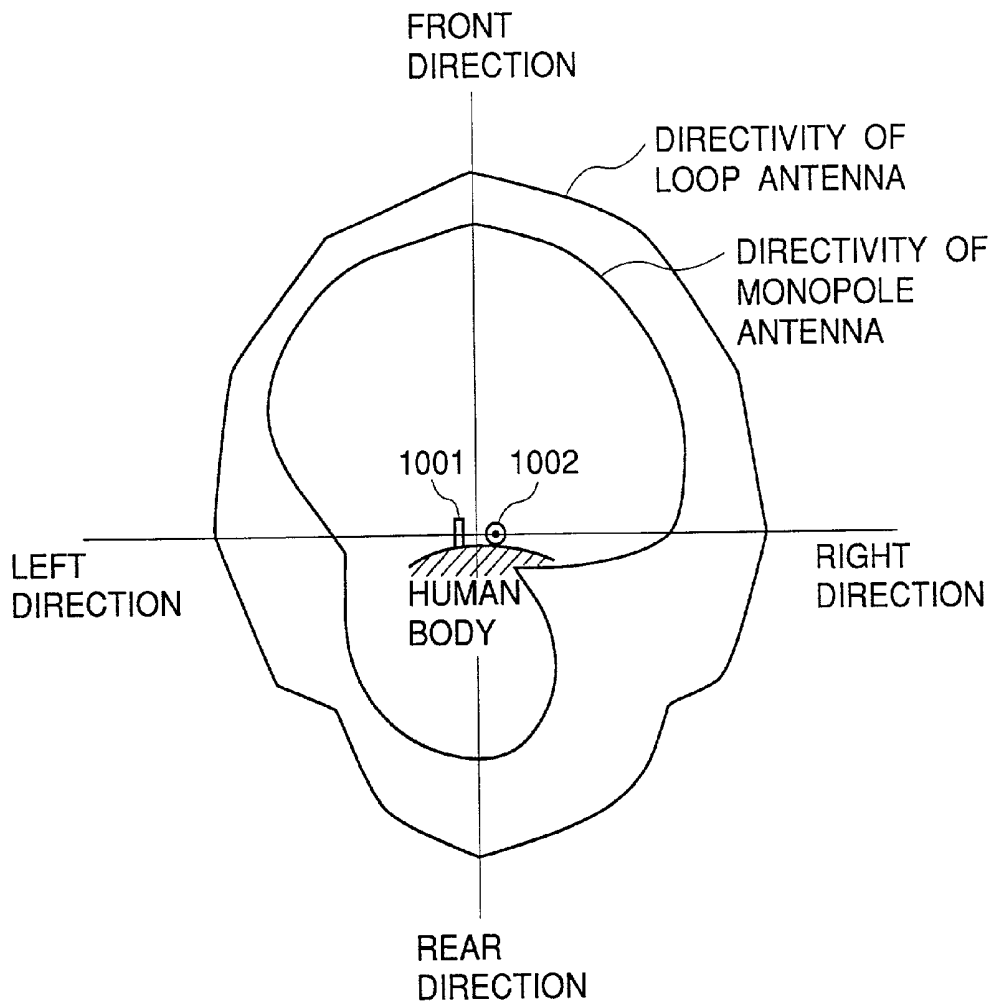

FIG.31(b)

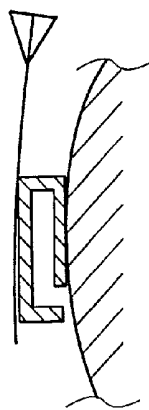

FIG.32(a)

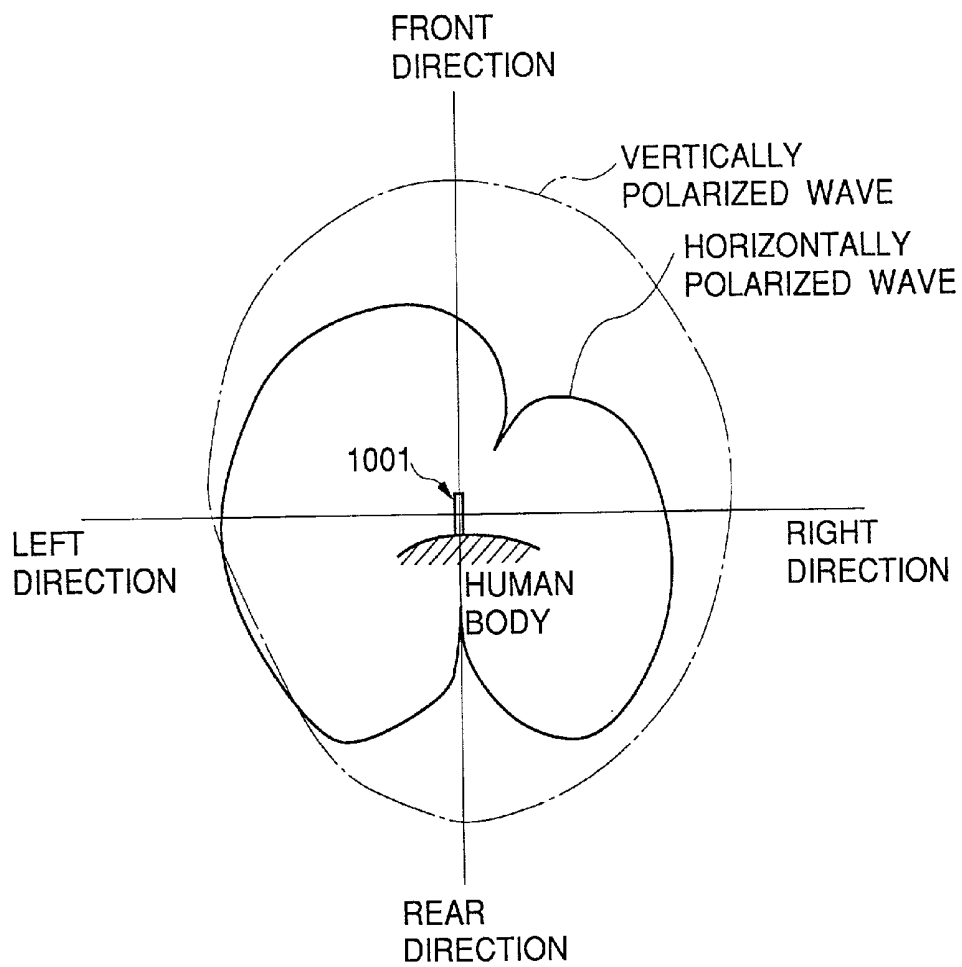

FIG.32(b)

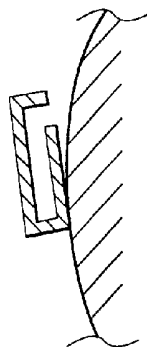

FIG.33(a)

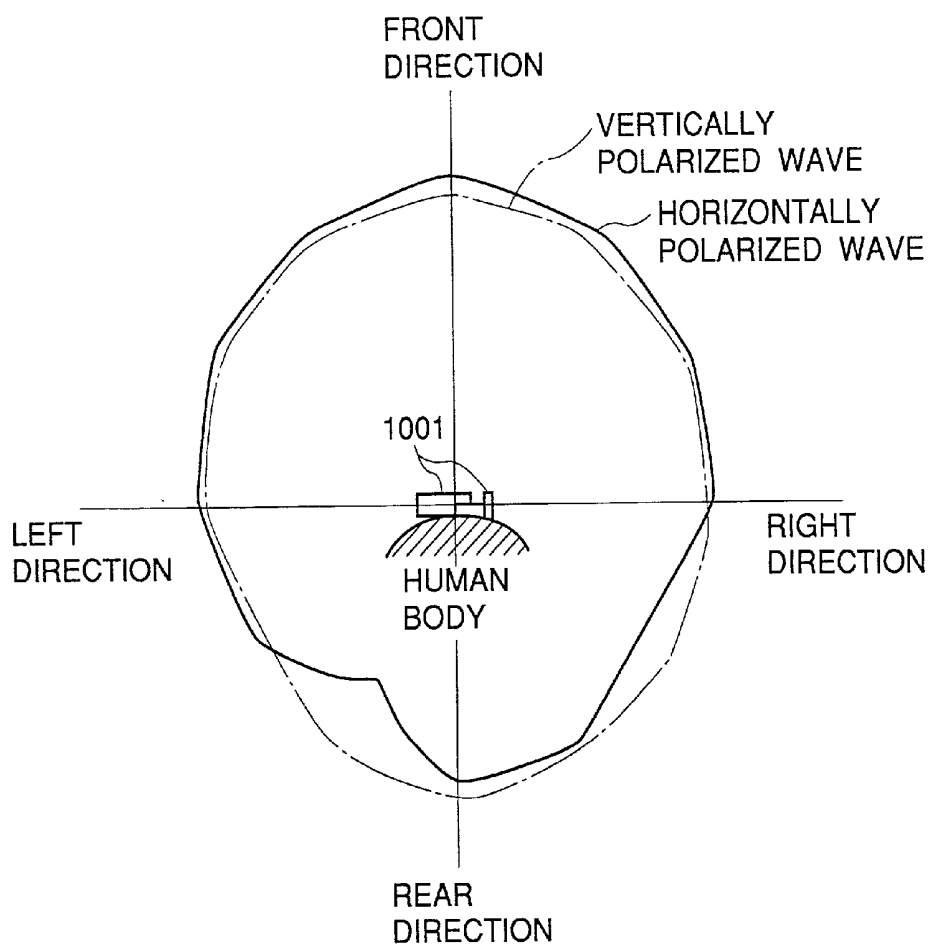

FIG.33(b)

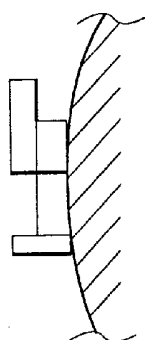

FIG.34 PRIOR ART

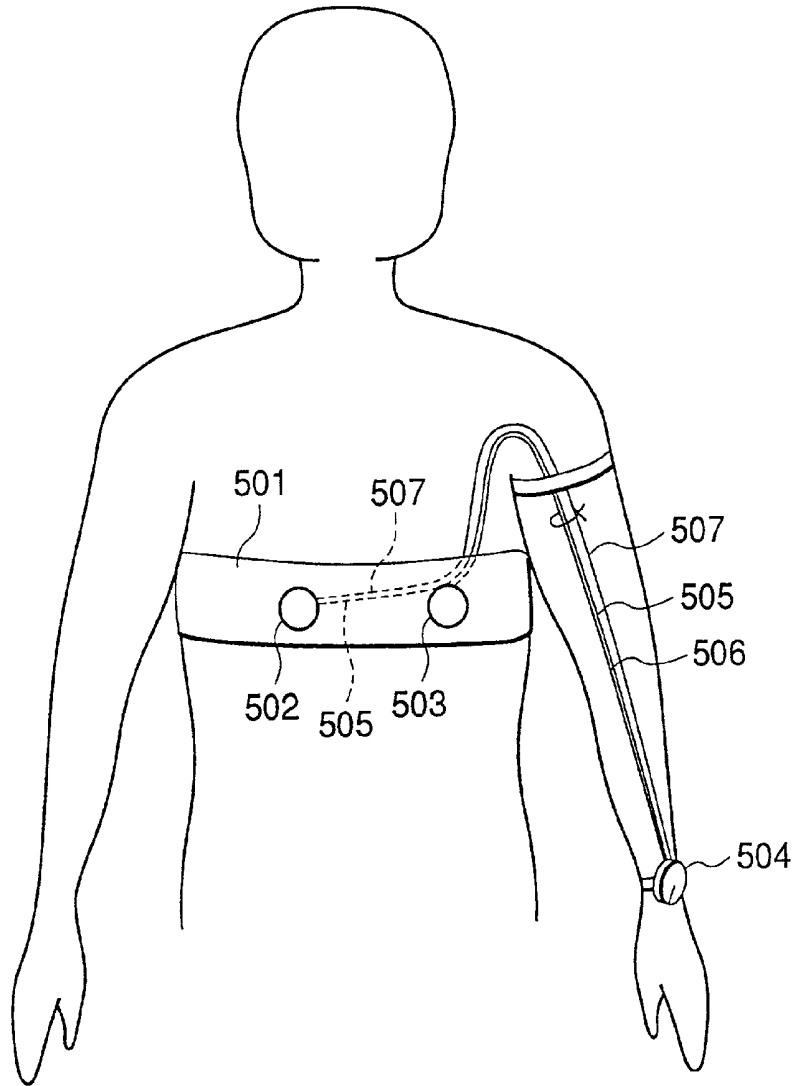

FIG.35 PRIOR ART

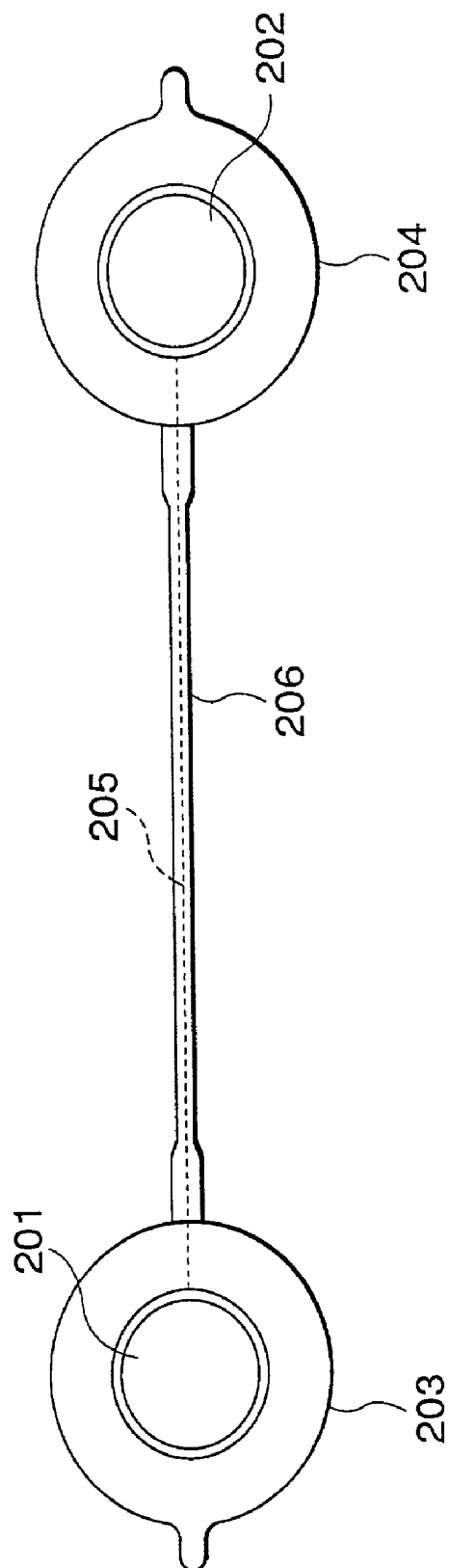

FIG.36 PRIOR ART

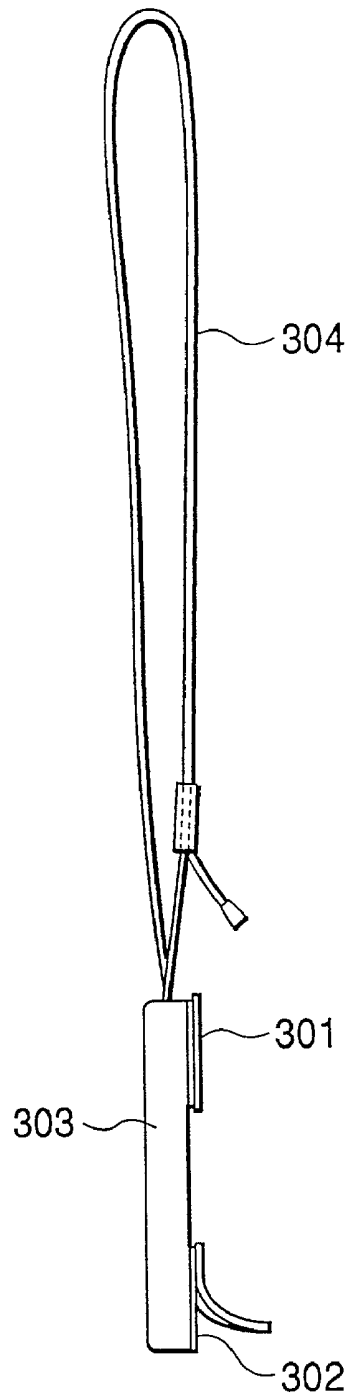

FIG.37 PRIOR ART

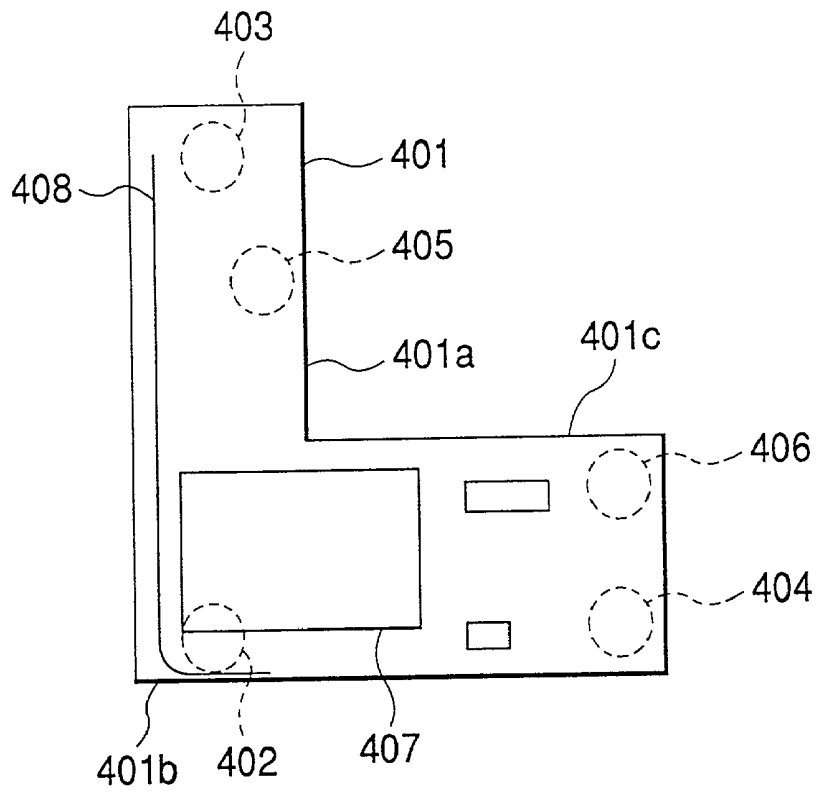

FIG.38

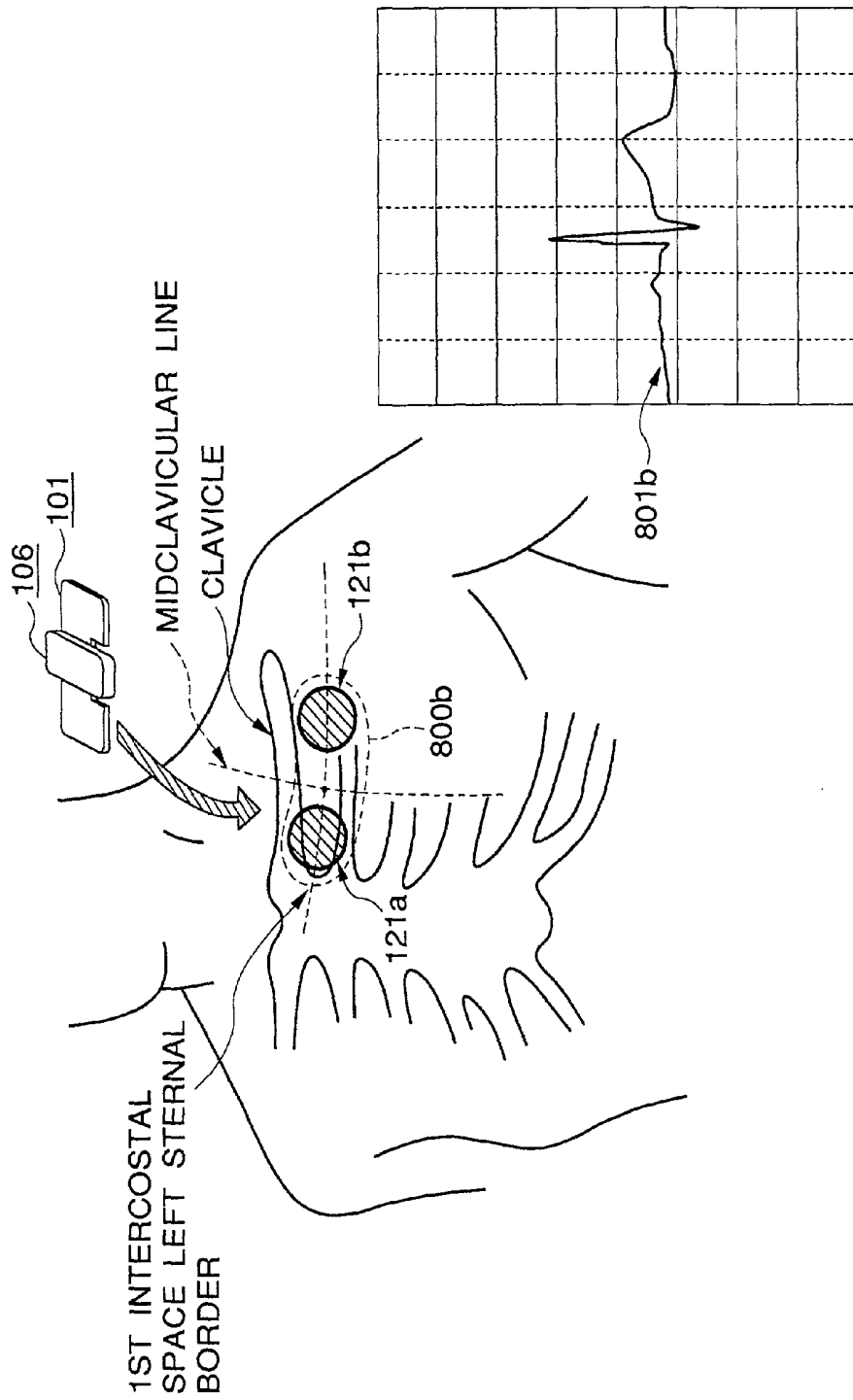
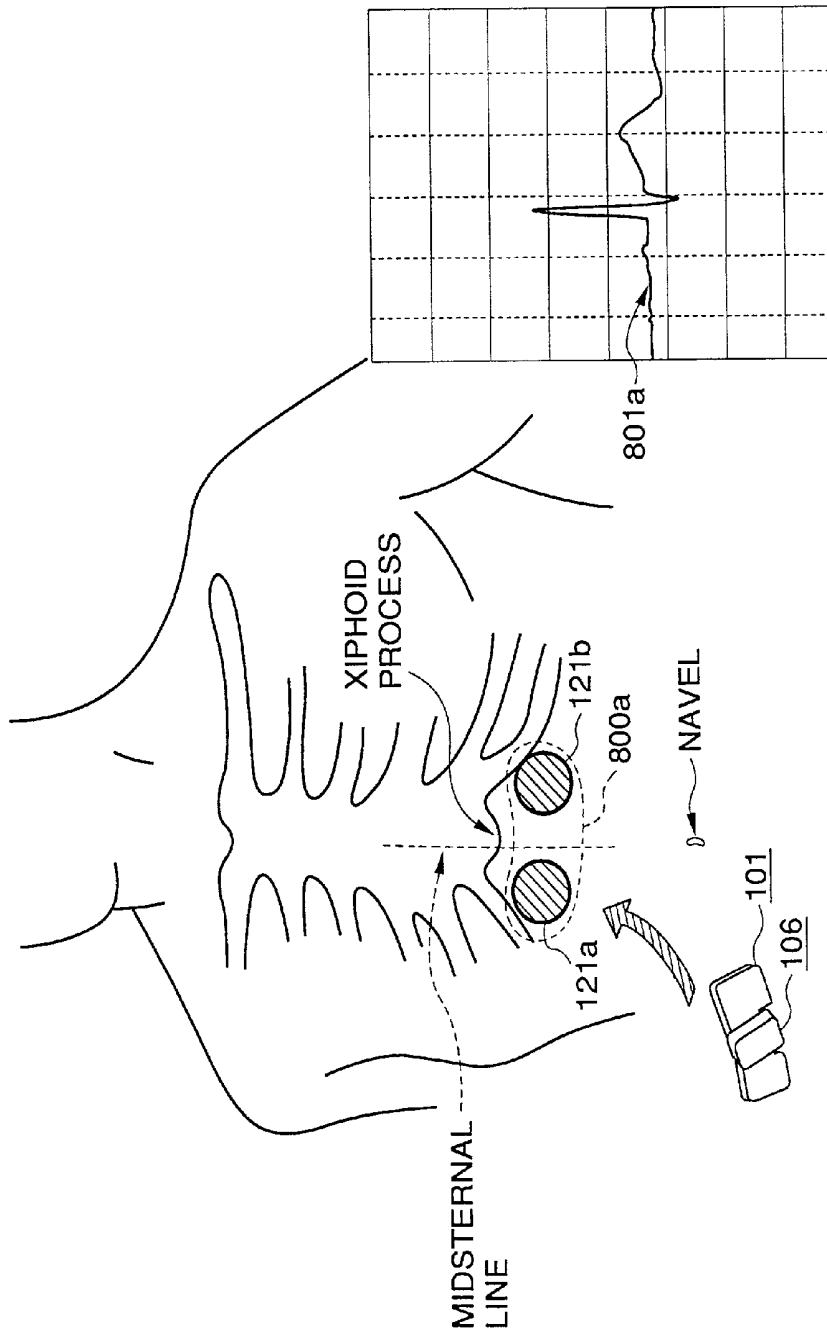

FIG.39



BIOLOGICAL SIGNAL TRANSMISSION APPARATUS

BACKGROUND OF THE INVENTION

[0001] 1. Field of the Invention

[0002] This invention relates to a biological signal transmission apparatus of a medical telemeter for transmitting a biological signal from a transmitter through an antenna to a receiver and in particular to a biological signal transmission apparatus using a loop antenna, a microstrip antenna as an antenna.

[0003] 2. Related Art

[0004] A system for transmitting by radio a biological signal detected on an electrode placed on a subject to a nearby computer diagnostic apparatus, etc., via an antenna for diagnosis is known. Hitherto, various propositions have been made as a transmission apparatus used with such a system.

[0005] In a proposition described in JP-A-60-97103U, two electrodes **502** and **503** attached to a chest belt **501** and a transmitter main unit **504** placed on a wrist of a subject are connected by electrode leads **505** and **506**, as shown in FIG. 34. An antenna line **507** from the transmitter main unit **504** is placed closely on the leads **505** and **506** in parallel therewith and an end of the antenna line **507** is buried in the chest belt **501**. The electrode leads **505** and **506** and the antenna line **507** are insulated from each other and the end of the antenna line **507** is also electrically insulated so as not to touch the body surface of the subject.

[0006] According to the proposition, the antenna line **507** is placed closely on the leads **505** and **506** and thus can be made 1 m or longer without disturbing any motion, and the efficiency of the transmitter **504** can be improved and miniaturized for enhancing portability of the transmitter.

[0007] In a proposition described in JP-A-62-202804U, a pair of electrodes **201** and **202** is placed in unit cases **203** and **204**, which are opened at bottoms for exposing the electrodes **201** and **202**, and both ends of an antenna line **205** are connected to the electrodes **201** and **202**, as shown in FIG. 35. The unit cases **203** and **204** are coupled by a connection cable **206** and the antenna line **205** is inserted into the connection cable **206**.

[0008] According to the proposition, the electrodes **201** and **202** placed in a pair of unit cases **203** and **204** are fitted to a heart rate detection part of a living body and a signal from the antenna line **205** is transmitted, so that the device is easily attached and detached and moreover can be placed without an oppressive feeling or a feeling of wrongness on the chest of the subject.

[0009] In a proposition described in JP-A-63-32501U, a device comprises a pair of electrodes **301** and **302**, a transmitter main unit **303** having electric circuitry for processing an electrocardiographic signal detected on the electrodes **301** and **302**, and an antenna **304** for sending the resultant signal to a receiver by a radio wave, as shown in FIG. 36. The antenna **304** is covered with water-repellent fibers and is put on the surface of a human body.

[0010] According to the proposition, the antenna **304** is covered with water-repellent fibers and is connected to the

transmitter main unit **303** so that it is put on the surface of a human body. Thus, when the device is attached to a subject, clothes of the subject do not swell locally and moreover it is not feared that the electrode **301**, **302** may be off the attachment point. Resultantly, sufficiently strong radio waves can be sent to the receiver in addition to ease of use.

[0011] In a proposition described in JP-A-9-108194, a base sheet **401** placed on the anterior chest wall of a subject is formed like an L letter, a longwise portion **401a** is put along the breast bone line of the subject, and a widthwise portion **401c** is directed toward the heart side from a corner **401b** positioned near the xiphisternum of the subject, as shown in FIG. 37. The base sheet **401** is formed on a rear with an adhesion layer made to adhere to the anterior chest wall. A first electrode **402** is attached in the proximity of the corner **401b**, a second electrode **403** is attached in the proximity of the upper end part of the longwise portion **401a**, and a third electrode **404** is attached in the proximity of a side end part of the widthwise portion **401c**. Further, a fourth electrode **405** is attached slantingly below the second electrode **403** and a fifth electrode **406** is attached above the third electrode **404**.

[0012] Of the five electrodes arranged as described above, α induction is detected between the electrodes **402** and **403** and β induction is detected between the electrodes **403** and **404**. γ induction for ischaemia of side and front and rear walls in a high-potential direction weak in sensitivity only with α induction and β induction is detected by means of the electrodes **405** and **406**. The electrocardiographic signals induced to the electrodes are amplified and modulated by a circuit unit **407** attached to the base sheet **401** and are transmitted to the receiver through an antenna **408** attached along the longwise portion **401a**.

[0013] According to the proposition, the electrodes **402** to **406**, the circuit unit **407**, and the antenna **408** are mounted integrally on the base sheet **401**, so that the device is easily placed on the subject and action is not limited.

[0014] In the examples in the related arts described above, the antennas are monopole antennas using the electricity length of a quarter the wave length. For example, assuming that the transmission frequency is 300 MHz, the wave length is 1 m and the antenna length becomes 25 cm. To place the monopole antenna so that it is not affected by a human body as much as possible, the monopole antenna may be placed in a direction perpendicular to the surface of a human body and distant from the human body. However, the antenna length is long (in this case, 25 cm), thus when the transmitter is placed on a human body, it disturbs the motion of the human body. If the transmitter is placed along the surface of the human body so as to facilitate the motion, radio waves radiated from the antenna are affected by the human body as described above, thus the gain is easily degraded. Also, although employing small and compact transmitter and electrode, there is still a problem that long using for standard limb lead (II) between electrodes disturb patient.

SUMMARY OF THE INVENTION

[0015] It is therefore an object of the invention to provide a small-sized biological signal transmission apparatus that can emit a biological signal detected on an electrode placed

on the surface of a living body to a receiver with stable and good sensitivity and can be easily placed on the living body.

[0016] According to an aspect of the present invention, there is provided a biological signal transmission apparatus comprising an electrode for detecting a biological signal, a support for supporting the electrode, the support being placed on a living body surface, a transmitter having electric circuitry for processing the biological signal detected on the electrode, and at least one loop antenna for emitting the biological signal processed by the electric circuitry to a receiver, the loop antenna being disposed so that an opening face is placed in a direction almost perpendicular to the living body surface.

[0017] According to another aspect of the present invention, there is provided a biological signal transmission apparatus comprising an electrode for detecting a biological signal, a support for supporting the electrode, the support being placed on a living body surface, a transmitter having electric circuitry for processing the biological signal detected on the electrode, and two loop antennas for emitting the biological signal processed by the electric circuitry to a receiver, the loop antennas being disposed so that opening faces are placed in a direction almost perpendicular to the living body surface and are almost at right angles to each other.

[0018] According to another aspect of the present invention, in the biological signal transmission apparatus, at least one of the loop antennas is contained in the transmitter.

[0019] According to another aspect of the present invention, in the biological signal transmission apparatus, at least one of the loop antennas is divided into two parts, one loop antenna division part is placed in the support and the other is placed in the transmitter, and the transmitter is placed on the support, thereby putting the loop antenna division parts into one piece.

[0020] According to another aspect of the present invention, in the biological signal transmission apparatus, the loop antenna is integral with the support and is connected at both ends to output of the electric circuitry through connection members and the transmitter is placed on the support.

[0021] According to another aspect of the present invention, there is provided a biological signal transmission apparatus comprising an electrode for detecting a biological signal, a support for supporting the electrode, the support being placed on a living body surface, a transmitter having electric circuitry for processing the biological signal detected on the electrode, at least one loop antenna for emitting the biological signal processed by the electric circuitry to a receiver, the loop antenna being disposed so that an opening face is placed in a direction almost perpendicular to the living body surface, and a microstrip antenna having a radiation plate and a base plate opposed in parallel with the living body surface, the base plate being placed nearer to the living body surface.

[0022] According to another aspect of the present invention, there is provided a biological signal transmission apparatus comprising an electrode for detecting a biological signal, a support for supporting the electrode, the support being placed on a living body surface, a transmitter having electric circuitry for processing the biological signal detected on the electrode, two loop antennas for emitting the

biological signal processed by the electric circuitry to a receiver, the loop antennas being disposed so that opening faces are placed in a direction almost perpendicular to the living body surface and are almost at right angles to each other, and a microstrip antenna having a radiation plate and a base plate opposed in parallel with the living body surface, the base plate being placed nearer to the living body surface.

[0023] In the biological signal transmission apparatus of the present invention, at least one of the loop antennas and the microstrip antenna is contained in the transmitter.

[0024] In the biological signal transmission apparatus of the present invention, at least one of the loop antennas and the microstrip antenna is integral with the support and the loop antenna or the microstrip antenna is connected to output of the electric circuitry through a connection member and the transmitter is placed on the support.

BRIEF DESCRIPTION OF THE DRAWINGS

[0025] In the accompanying drawings:

[0026] FIG. 1 is a block diagram to show a configuration example of a first embodiment of a biological signal transmission apparatus of the invention;

[0027] FIG. 2 is a longitudinal sectional view to show the configuration of a living body placement section in FIG. 1;

[0028] FIG. 3 is an exploded perspective view of the living body placement section shown in FIG. 2;

[0029] FIG. 4 is an external perspective view of the living body placement section and a transmitter in FIG. 1;

[0030] FIG. 5 is a plan view to show the form of a modified example of a support in FIG. 3;

[0031] FIG. 6 is a perspective view to show the structure of a loop antenna in FIG. 3;

[0032] FIG. 7 is a perspective view to show the structure of a modified example of the loop antenna in FIG. 3;

[0033] FIG. 8 is an exploded longitudinal sectional view to show the attachment structure of an electrode in FIG. 2 and FIG. 3;

[0034] FIG. 9 is a block diagram to show a configuration example of a second embodiment of the invention;

[0035] FIG. 10 is an exploded perspective view to show a configuration example of a living body placement section and a transmitter in FIG. 9;

[0036] FIG. 11 is an external perspective view of the living body placement section and the transmitter in FIG. 9;

[0037] FIG. 12 is a block diagram of a living body placement section to show a configuration wherein electrodes in FIG. 9 are replaced with a transducer;

[0038] FIG. 13 is a longitudinal sectional view to show a configuration example of a third embodiment of the invention;

[0039] FIG. 14 is a block diagram to show the configuration of a fourth embodiment of a biological signal transmission apparatus of the invention;

[0040] FIG. 15 is an exploded perspective view to show a configuration example of a living body placement section in FIG. 14;

[0041] FIG. 16 is an external perspective view of the living body placement section shown in FIG. 15 and a transmitter placed thereon;

[0042] FIG. 17 is a plan view to show the form of a modified example of a support in FIG. 15;

[0043] FIG. 18 is an exploded longitudinal sectional view to show the attachment structure of an electrode in FIG. 17;

[0044] FIG. 19 is an external perspective view to show another configuration example of the living body placement section in FIG. 14;

[0045] FIG. 20 is an external perspective view of the living body placement section shown in FIG. 19 and a transmitter placed thereon;

[0046] FIG. 21 is a block diagram to show a configuration example of a fifth embodiment of the invention;

[0047] FIG. 22 is an exploded perspective view to show a configuration example of a living body placement section in FIG. 21;

[0048] FIG. 23 is an external perspective view of the living body placement section shown in FIG. 22 and a transmitter placed thereon;

[0049] FIG. 24 is a schematic representation to show placement of antennas when the transmitter in FIG. 23 is placed on the living body placement section;

[0050] FIG. 25 is a block diagram to show a configuration example of a sixth embodiment of the invention;

[0051] FIG. 26 is an exploded perspective view to show a configuration example of a living body placement section in FIG. 25;

[0052] FIG. 27 is an external perspective view of the living body placement section shown in FIG. 26 and a transmitter placed thereon;

[0053] FIG. 28 is a block diagram to show a configuration example of a seventh embodiment of the invention;

[0054] FIG. 29 is an exploded perspective view to show a configuration example of a living body placement section and a transmitter in FIG. 28;

[0055] FIG. 30 is an illustration to show an example of placing the biological signal transmission apparatus of the invention on a living body;

[0056] FIG. 31(a) is a plan view of an illustration to compare a loop antenna and a monopole antenna placed on a human body in directivity and FIG. 31(b) is side view of the arrangement of the loop antenna and the monopole antenna attached with the human body along with FIG. 31(a);

[0057] FIG. 32(a) is a plan view of an illustration to show the directivity of one loop antenna placed on a human body, and FIG. 32(b) is side view of the arrangement of one loop antenna attached with the human body along with FIG. 32(a);

[0058] FIG. 33(a) is a plan view of an illustration to show the directivity of two loop antennas placed on a human body, and FIG. 33(b) is side view of the arrangement of two loop antennas attached with the human body along with FIG. 33(a);

[0059] FIG. 34 is a front view to show the configuration of a first example of a biological signal transmission apparatus in a related art;

[0060] FIG. 35 is a plan view to show the configuration of a second example of a biological signal transmission apparatus in a related art;

[0061] FIG. 36 is a front view to show the configuration of a third example of a biological signal transmission apparatus in a related art;

[0062] FIG. 37 is a plan view to show the configuration of a fourth example of a biological signal transmission apparatus in a related art;

[0063] FIG. 38 is a front view of the water-containing gels positioned through midclavicular line and parallel to a clavicle; and

[0064] FIG. 39 is a front view of the water-containing gels attached on a chest defined between a xiphoid process and a navel through and perpendicular to a midsternal line.

DETAILED DESCRIPTION OF THE PREFERRED EMBODIMENTS

[0065] Referring now to the accompanying drawings, there are shown preferred embodiments of a biological signal transmission apparatus of the invention. FIG. 1 is a block diagram to show a configuration example of a first embodiment of the invention. FIG. 2 is a longitudinal sectional view to show the configuration of a living body placement section in FIG. 1. FIG. 3 is an exploded perspective view of the living body placement section shown in FIG. 2. FIG. 4 is an external perspective view of the living body placement section and a transmitter in FIG. 1.

[0066] In FIG. 1, a living body placement section 1 comprises a loop antenna 3 and an electrode 4 integrally mounted on a flat support 2 formed of an insulating material. A transmitter 5 comprises electric circuitry 10 made up of an amplification section 6, a modulation section 7, a power supply section 8, and a transmission section 9. The electrode 4 and the amplification section 6 and the loop antenna 3 and the transmission section 9 are electrically connected through connectors 11, 12, and 13. Numeral 14 is an electrode placed on another part of a living body. The electrode 14 is connected to the amplification section 6 by a connector 15.

[0067] Power is supplied from the power supply section 8 to the amplification section 6, the modulation section 7, and the transmission section 9. When the support 2 is placed on the living body surface of a subject, a biological signal detected on the electrode 4 is amplified by the amplification section 6 and is modulated by the modulation section 7, then is sent from the transmission section 9 to the loop antenna 3. The biological signal is transmitted by radio from the loop antenna 3 to a receiver (not shown).

[0068] In FIG. 2 and FIG. 3, the support 2 is formed of an insulating material like a square plate. The loop antenna 3 formed of a conductive material like a belt is placed along

one side of the lower face of the support **2** and the loop antenna **3** is folded at both ends back to the upper face of the support **2** so as to sandwich the support **2**. Convex hooks **16** and **17** forming a connector are fixed at both ends of the loop antenna **3**.

[0069] The electrode **4** passes through the support **2** from the lower face thereof, projects upward, and is fixedly secured in the portion of the support **2** where the loop antenna **3** is not placed. Conductive water-containing gel **18** is applied to the lower end face of the electrode **4**. A hook **19** is attached to one end of the electrode **4** passing through the support **2** from the lower face thereof and projecting upward. An insulating sheet **20** covering the loop antenna **3** is bonded to the full lower face of the support **2** and the electrode **4** is exposed to the lower face through a hole **20a** made in the insulating sheet **20**. An adhesive **21** is applied to the lower face of the insulating sheet **20**. The upper face of the support **2** is also covered with an insulating sheet **22** and the hooks **16**, **17**, and **19** pass through the insulating sheet **22** and project upward.

[0070] The transmitter **5** is placed on and fixed to the described living body placement section **1**, as shown in FIG. 4. At this time, the hooks **16**, **17**, and **19** are connected to the corresponding connectors (not shown) of the transmission section **9** and the amplification section **6** in the transmitter **5**. As shown in FIG. 30, when the living body placement section **1** is bonded to the surface of the living body of a subject via the adhesive **21**, a biological signal detected on the electrode **4** is sent through the hook **19** to the transmitter **5** and is processed by the electric circuitry **10** in the transmitter **5**, then is sent through the hooks **16** and **17** to the loop antenna **3** from which the biological signal is transmitted to the receiver (not shown) by radio.

First Embodiment

[0071] Next, specific structures and materials of the parts of the first embodiment shown in FIG. 1 to FIG. 4 will be discussed in detail. The support **2** is several ten μm to several mm thick, for example, and has reasonable rigidity for holding the living body placement section **1**. In the above-described example, the support **2** is shaped like a square plate, but may be of any shape like a center-constricted plate, for example, as shown in FIG. 5. For example, the support **2** is formed of a material of paper or a macromolecular dielectric substance, such as vinyl chloride, polyurethane, polystyrene, polycarbonate, polypropylene, fluororesin, silicone resin, cellulose acetate, polyester, rayon, nylon, vinylon, epoxy resin, or ceramics.

[0072] The loop antenna **3** is several μm to several mm thick, for example, has a surrounding length of about a several'th to a several tenth the wave length, and is formed of an elongated conductive film. The planar shape is not limited; for example, the loop antenna **3** may be narrow as shown in FIG. 6 or may be wide as shown in FIG. 7. For example, metal, carbon, a macromolecular conductive substance, or resin to which conductive plating is given is used as the material of the loop antenna **3**.

[0073] The electrode **4** is fixed to the support **2** through the connector **11**, is a conductive substance itself, and acts as an electrode for deriving a living body electricity phenomenon. It may be of any structure if it can be stably fixed to the hook **19** as the connector, for example, as shown in FIG. 8. The

material of the electrode **4** may be a conductive substance similar to connector described later, and is not limited. For example, a macromolecular conductive substance, such as conductive rubber or water-containing resin, metal, such as copper, stainless steel, or aluminum, carbon, such as carbon fibers or graphite, resin to which conductive plating is given (for example, a conductive metal film of gold, silver, copper, nickel, aluminum, palladium, platinum, etc., is formed on the surface of a macromolecular insulating substance or a macromolecular conductive substance by means of sputtering evaporation, electrolytic plating, electroless plating, etc.) is used as the material of the electrode **4**.

[0074] The water-containing gel **18** makes electric conduction between the electrode **4** and a living body surface and preferably it has adhesion to a living body. For example, gelatin, polyacrylic acid, its salt, karaya gum, any other water-soluble or water-dispersable acrylic-family polymer, water-soluble or water-dispersable polymer of polyacrylamide, polyvinyl alcohol, carboxymethyl cellulose, polyurethane, etc., or the like can be named as the base material for forming the gel layer.

[0075] In the above-described example, the hooks **16**, **17**, and **19** are used as the parts forming the connectors **11**, **12**, and **13**, but the scope of the invention is not limited to them. For example, a structure of a general-purpose electric connector, a contact-type connector, etc., may be used. A material similar to that of the electrode **4** described above can be used.

[0076] The insulating sheets **20** and **22** are provided so that a human body and the loop antenna **3** do not come in direct contact with each other. They may be made of any material if the material has an insulating property; the material is not limited.

[0077] The adhesive **21** is provided for strongly fixing the living body placement section **1** to a living body; preferably it is a substance not giving an impetus to the living body. For example, a known adhesive material excellent in intimate contact with the living body placement section **1**, such as double-sided adhesive tape, an acrylic family, a rubber family, or a vinyl ether family, can be used.

[0078] According to the embodiment, the loop antenna **3** is placed near the surface of a living body through the support **2** and moreover the opening face of the loop antenna **3** is almost at right angles to the living body surface, so that the sensitivity can be improved and the gain can be increased because of the known loop antenna characteristics.

Second Embodiment

[0079] FIG. 9 to FIG. 11 show a configuration example of a second embodiment of the invention. Parts identical with or similar to those previously described with reference to FIG. 1 to FIG. 4 are denoted by the same reference numerals in FIG. 9 to FIG. 11 and will not be discussed again in detail.

[0080] In the second embodiment, the number of electrodes **4** is two and biological signals detected on electrodes **4a** and **4b** are sent through connectors **11a** and **11b** to an amplification section **6**, as shown in FIG. 9. Other components and functions are almost similar to those of the first embodiment previously described with reference to FIG. 1 to FIG. 4.

[0081] FIG. 10 is an exploded perspective view to show a configuration example of a living body placement section 1 and a transmitter 5 in FIG. 9. FIG. 11 is an external perspective view of the living body placement section 1 and the transmitter 5 in FIG. 9. In FIG. 10, ends of conductive terminals 18c and 18d disposed on the lower face of a support 2 are electrically connected to caulking devices 31a and 31b respectively, and conductive water-containing gels 18a and 18b are attached to opposite ends of the conductive terminals 18c and 18d. The caulking devices 31a and 31b pass through the support 2 and project upward and are fixed to the support 2 together with the conductive terminals 18c and 18d.

[0082] A loop antenna 3 is placed on the lower face of the support 2 between the conductive terminals 18c and 18d and is folded at both ends back to the upper face of the support 2 so as to sandwich the support 2. An insulating sheet 20 for covering the loop antenna 3, the caulking devices 31a and 31b, and the conductive terminals 18c and 18d is bonded to the space between the conductive water-containing gels 18a and 18b on the lower face of the support 2, and an adhesive 21 is applied to the lower face of the insulating sheet 20.

[0083] The upper face of the support 2 is also covered with an insulating sheet 22. Convex hooks 19a and 19b placed at the upper ends of the caulking devices 31a and 31b and convex hooks 16 and 17 fixed to both ends of the loop antenna 3 pass through the insulating sheet 22 and project upward. A transmitter 5 is made up of an upper lid 40a and a lower lid 40b making up a cabinet 40, a board 41 housed therein, and electric circuitry 10 mounted on the board 41. The board 41 is formed on a surface with four lands 42 connected to the electric circuitry 10. It is fixed to the lower lid 40b through the lands 42 by a caulking device 43 and a concave hook 44. Also in the embodiment, as shown in FIG. 11, the transmitter 5 is placed on and fixed to a living body placement section 1 through the convex hooks 16, 17, 19a, and 19b and the concave hook 44, and the functions and advantages similar to those of the first embodiment previously described with reference to FIG. 1 to FIG. 4 can be provided. The structures and materials of the members shown in FIG. 9 to FIG. 11 are almost similar to those of the first embodiment previously described with reference to FIG. 1 to FIG. 4.

[0084] In the second embodiment, the number of the electrodes 4 is two, but three or more electrodes 4 may be used. In this case, the electrodes 4 are placed at appropriate positions of the living body placement section 1 and are related to the connectors 11 and the amplification section 6 and a modulation section 7 in the electric circuitry 10, whereby a large number of biological signals can be derived and amplified, then transmitted from a transmission section 9, needless to say.

[0085] As shown in FIG. 12, the electrodes 4 are replaced with a transducer 23, whereby the temperature, blood pressure, etc., of a living body can also be detected.

Third Embodiment

[0086] FIG. 13 is a longitudinal sectional view to show a configuration example of a third embodiment of the invention. Parts identical with or similar to those previously described with reference to FIG. 1 to FIG. 4 are denoted by the same reference numerals in FIG. 13 and will not be

discussed again in detail. The third embodiment is characterized by the fact that a part of a loop antenna 3 is formed according to a thin film technology of silk print, etc. As shown in FIG. 13, through holes are made near two opposed sides of a support 2 and are filled with conductive material 24. The support 2 is formed on both faces with conductive thin films 25 according to the thin film technology and the upper conductive thin film 25 is divided into two portions. The upper and lower conductive thin films 25 are electrically connected at both ends to the conductive material 24 with which the through holes are filled, forming the loop antenna 3.

[0087] The upper and lower faces of the support 2 are covered with insulating sheets 20 and 22 for covering the conductive thin films 25 and the upper insulating sheet 22 is cut at the center for exposing the conductive thin film 25 at both ends thereof. When a transmitter 5 is placed on a living body placement section 1, a pair of conductive contact connectors 26 projecting from the lower face of the transmitter 5 abuts the exposure parts of the conductive thin film 25 at both ends thereof for introducing a signal transmitted from the transmitter 5 into the loop antenna formed of the conductive thin films 25. A hook 19 fixed to an electrode 4 is coupled to a connector 11 like a concave hook to the transmitter 5, as in the first embodiment.

[0088] According to the third embodiment, the manufacturing process is simplified and costs can be reduced as compared with the case where the loop antenna 3 is formed as a thin-film separate body and is folded at both ends back to the support 2 and fixed as in the configuration examples of the first and second embodiments.

[0089] In FIG. 13, one electrode 4 is shown, but the third embodiment can also be applied to the case where the number of the electrodes 4 is two or more as in the configuration example of the second embodiment shown in FIG. 9 and FIG. 10 and the case where the electrode 4 is the transducer 23 as shown in FIG. 12; similar advantages can be provided.

Fourth Embodiment

[0090] FIG. 14 is a block diagram to show a configuration example of a fourth embodiment of the invention. FIG. 15 is an exploded perspective view to show a specific configuration example of a living body placement section in FIG. 14. FIG. 16 is an external perspective view of the living body placement section shown in FIG. 14 and a transmitter placed thereon. FIG. 17 is a plan view to show the form of a modified example of a support in FIG. 15. FIG. 18 is a drawing to show the attachment structure of an electrode in FIG. 17.

[0091] In FIG. 14, a living body placement section 101 comprises division parts 103a and 104a of two antennas 103 and 104 each divided into two parts and two electrodes 105a and 105b mounted on a flat support 102 formed of an insulating material. In the embodiment, the antenna 103 is a loop antenna and the antenna 104 is a microstrip antenna (MSA). A transmitter 106 comprises electric circuitry 111 made up of an amplification section 107, a modulation section 108, a power supply section 109, and a transmission section 110 and other division parts 103b and 104b of the two antennas 103 and 104. The electrodes 105a and 105b and the amplification section 107 are connected through

connectors **112a** and **112b**, one end of the part **103a** of the antenna **103** and one end of the part **103b** of the antenna **103** are connected through a connector **113a**, and the opposite end of the part **103a** of the antenna **103** and the transmission section **110** are connected through a connector **113b**. The opposite end of the part **103b** of the antenna **103** is connected to the transmission section **110**. The part **104a** of the antenna **104** (MSA) is a base plate and the part **104b** of the antenna **104** is a radiation plate. The base plate **104a** is connected to the transmission section **110** through a connector **114** and the radiation plate **104b** is directly connected to the transmission section **110**.

[0092] Power is supplied from the power supply section **109** to the amplification section **107**, the modulation section **108**, and the transmission section **110**. When the support **102** is placed on the living body surface of a subject, biological signals detected on the electrodes **105a** and **105b** are amplified by the amplification section **107** and are modulated by the modulation section **108**, then are sent from the transmission section **110** to the antennas **103** and **104**. The biological signals are transmitted by radio from the antennas **103** and **104** to a receiver (not shown).

[0093] In **FIG. 15** and **FIG. 16**, the support **102** is formed of a dielectric material like a rectangular plate. The loop antenna **103** formed of a conductive material like a belt is divided into two parts. One loop antenna part **103a** is placed on one side of the lower face of the support **102** and caulking devices **115a** and **115b** are inserted into both ends of the loop antenna part **103a**. The caulking devices **115a** and **115b** pass through the loop antenna part **103a** from the lower face thereof and further pass through the support **102** and project upward. Hooks **116a** and **116b** are fixed to the projection ends of the caulking devices **115a** and **115b** by caulking. The loop antenna part **103b** is connected at one end to the hook **116a**. The hook **116b** is connected to the transmission section **110**.

[0094] As described above, the MSA **104** consists of the base plate **104a** and the radiation plate **104b**, which are opposed to each other in parallel. As shown in **FIG. 15**, the base plate **104a** is fixed almost at the center of the lower face of the support **102** and is formed with a projection **141a** at the center of one side opposite to the loop antenna part **103a**. A caulking device **117** is inserted into the projection **141a**; it passes through the base plate **114a** from the lower face thereof and further passes through the support **102** and projects upward. A hook **118** for the base plate is fixed to the projection ends of the caulking device **117** by caulking.

[0095] A pair of plate-like conductive terminals **121c** and **121d** is placed at both sides of the projection **141a** of the base plate **104a** in parallel with one side of the base plate **104a** and are fixed to the lower face of the support **102**. Caulking devices **119a** and **119b** are inserted into opposed ends of the conductive terminals **121c** and **121d**; they pass through the conductive terminals **121c** and **121d** from the lower faces thereof and further pass through the support **102** and project upward. Hooks **120a** and **120b** for deriving electrocardiographic signals are fixed to the projection ends of the caulking devices **119a** and **119b** by caulking. Conductive water-containing gels **121a** and **121b** are attached to outer ends of the conductive terminals **121c** and **121d**. Further, the lower faces of the loop antenna part **103a**, the base plate **104a**, and the conductive terminals **121c** and **121d**

are covered with an insulating sheet **122** and an adhesive **123** is applied to the lower face of the insulating sheet **122**.

[0096] The transmitter **106** is shaped like a square can as shown in **FIG. 16** and contains a board (not shown) on which the electric circuitry **111** is mounted. On the board, the loop antenna part **103b** and the radiation plate **104b** are placed at the positions corresponding to the loop antenna part **103a** and the base plate **104a** in the living body placement section **101**, as shown in **FIG. 15**. When the transmitter **106** is attached to the living body placement section **101**, the hook **116a** projecting from the top of the support **102** of the living body placement section **101** is fitted to one end of the loop antenna part **103b** and the convex hooks **118**, **120a**, and **120b** are connected to concave hooks **124**, **125a**, and **125b** formed at predetermined positions of the board. The concave hooks **124**, **125a**, and **125b** are connected to the electric circuitry **111**. Further, the opposite end of the loop antenna part **103b** is also connected to the electric circuitry **111**.

[0097] Next, specific structures and materials of the parts of the fourth embodiment shown in **FIG. 14** to **FIG. 18** will be discussed in detail. The support **102** is formed of a dielectric substance which is several ten μm to several mm thick, for example, and has reasonable rigidity and dielectric constant for holding the living body placement section **101**. In the above-described example, the support **102** is shaped like a rectangular plate, but may be of any shape like a hand drum, for example, as shown in **FIG. 17**. The support **102** may be formed of a material of a dielectric substance having a dielectric constant fitted to the use frequency and the shapes of the base plate **104a** and the radiation plate **104b**, for example, paper or a macromolecular dielectric substance, such as vinyl chloride, polyurethane, polystyrene, polycarbonate, polypropylene, fluoroplastics, silicone resin, cellulose acetate, polyester, rayon, nylon, vinylon, epoxy resin, or ceramics.

[0098] The loop antenna **103** is several μm to several mm thick, for example, has a surrounding length of about a several'th to a several tenth the wave length, and is formed of an elongated conductive film. The planar shape is not limited. For example, metal, carbon, a macromolecular conductive substance, or resin to which conductive plating is given is used as the material of the loop antenna **103**.

[0099] The base plate **104a** basically has a large area in the allowable range and a structure for making a signal emitted from the radiation plate **104b** hard to be affected by a human body, etc. For example, metal, carbon, a macromolecular conductive substance, or resin to which conductive plating is given is used as the material of the base plate **104a**. The shape of the base plate **104a** also changes corresponding to the antenna characteristics.

[0100] The radiation plate **104b** is formed of a conductive film which is several μm to several mm thick, for example, and has an area determined by frequency. In the above-described example, the radiation plate **104b** is shaped like a rectangular plate, but may be of any shape. For example, metal, carbon, a macromolecular conductive substance, or resin to which conductive plating is given is used as the material of the radiation plate **104b** like the base plate **104a**.

[0101] The caulking devices **115a**, **115b**, **117**, **119a**, and **119b** and the conductive terminals **121c** and **121d** are fixed

to the support **102** through the hooks **116a**, **116b**, **118**, **120a**, and **120b**, are conductive substances themselves, and act as electrodes for deriving a living body electricity phenomenon and electrodes for transferring signals to the base plate **104a**. They may be of any structure if it can be stably fixed to the hook **120** as the connector, for example, as shown in **FIG. 18**. The material may be a conductive substance and is not limited. For example, a macromolecular conductive substance, such as conductive rubber or water-containing resin, metal, such as copper, stainless steel, or aluminum, carbon, such as carbon fibers or graphite, resin to which conductive plating is given (for example, a conductive metal film of gold, silver, copper, nickel, aluminum, palladium, platinum, etc.), is formed on the surface of a macromolecular insulating substance or a macromolecular conductive substance by means of sputtering evaporation, electrolytic plating, electroless plating, etc.) is used as the material.

[0102] In the above-described example, the hooks **116a**, **116b**, **118**, **120a**, and **120b** are used as the parts forming the connectors **112c**, **112d**, **113c**, **113d**, and **114**, but the scope of the invention is not limited to them. For example, a structure of a general-purpose electric connector, a contact-type connector, etc., may be used. A material similar to that of the caulking devices **115a**, **115b**, **117**, **119a** and **119b** described above can be used.

[0103] The water-containing gel **121a**, **121b** makes electric conduction between the conductive terminal **121c**, **121d** and a living body surface and preferably it has adhesion to a living body. For example, gelatin, polyacrylic acid, its salt, karaya gum, any other water-soluble or water-dispersible acrylic-family polymer, polyacrylic-family polymer, water-soluble or water-dispersible polymer of polyacrylamide, polyvinyl alcohol, carboxymethyl cellulose, polyurethane, etc., or the like can be named as the base material for forming the gel layer. The length and breadth of the water-containing gels **121a**, **121b** to be attached to living body is the range from approximately 2 to 6 cm. But the shape of the water-containing gels are not limited as described shape, and any figure like a square, rectangle, circle, oval are applicable.

[0104] Preferably, the distance between nearest of water-containing gels **121a**, **121b** is the range from approximately 1.0 to 7.5 cm to detect heart rate information and etc. And more specifically, it's preferable to make the distance approximately 2.0 to 7.5 cm to detect a small amplitude P wave of ECG sufficiently.

[0105] The insulating sheet **122** is provided so that a human body and the radiation plate **104b** and the base plate **104a** making up the antenna do not come in direct contact with each other. It may be made of any material if the material has an insulating property; the material is not limited.

[0106] The adhesive **123** is provided for strongly fixing the living body placement section **101** to a living body; preferably it is a substance not giving an impetus to the living body. For example, a known adhesive material excellent in intimate contact with the living body placement section **101**, such as double-sided adhesive tape, an acrylic family, a rubber family, a silicone family, or a vinyl ether family, can be used.

[0107] The transmitter **106** is attached to the living body placement section **101** as described above, whereby the loop

antenna parts **103a** and **103b** are connected, forming one loop antenna **103**, and the base plate **104a** and the radiation plate **104b** are connected through the circuit on the board, forming the MSA **104**. When the described biological signal transmission apparatus is placed on a living body surface as shown in **FIG. 30**, the living body placement section **101** is bonded to the surface of the living body of a subject via the adhesive **123** and the water-containing gels **121a** and **121b** are attached at a first intercostal space left sternal border on a left chest along a position **800b** in such a manner that the water-containing gels **121a** and **121b** are positioned through midclavicular line and are parallel to a clavicle, as shown in **FIG. 38**. Thus, there is obtained biological signals **801b** which is highly correct to ECG detected in the method of standard limb lead (II). In addition, the stable ECG having high correction with ECG of standard limb lead (II) can be obtained as long as the living body placement section is attached to area within the range of 2.5 cm apart from the **800b**, or second intercostal space and it's not always needed to position water-containing gels **121a** and **121b** through midclavicular line.

[0108] Upon the attachment, as shown in **FIG. 39**, the water-containing gels **121a** and **121b** are attached on a chest defied between a xiphoid process and a navel through and perpendicular to a midsternal line so as to obtain biological signals **801a** which is highly correlative to ECG detected in the method of standard limb lead (II).

[0109] In addition, the stable ECG having high correlation to ECG of standard limb lead (II) can be obtained as long as the living body placement section is attached to area within the range of 2.5 cm apart from the **800a**, and it's not always needed to position water-containing gels **121a** and **121b** through midsternal line.

[0110] Biological signals detected on the conductive terminals **121c** and **121d** are sent through the hooks **120a** and **120b** to the transmitter **106** and are processed by the electric circuitry **111** in the transmitter **106**, then are sent through the hooks **116a** and **116b** to the loop antenna **103** and through the hook **118** to the MSA **104** from which the biological signals are transmitted to the receiver (not shown) by radio.

[0111] According to the embodiment, the biological signals detected on the electrodes **105a** and **105b** are transmitted by radio through the loop antenna **103** and the MSA **104** different in characteristics, so that the directivity can be improved, the radiation capability can be enhanced, and the radio wave band width can be enlarged. The loop antenna **103** and the MSA **104** are each divided into two parts, one of which is placed in the support **102** and the other in the transmitter **106**. Thus, the transmitter **106** can be miniaturized as compared with the case where the whole antennas are installed in the transmitter **106**.

[0112] In the embodiment, the two electrodes **105** are used, but similar functions and advantages can be provided if one electrode **105** is used. Two loop antennas **103** each divided into two parts (**103a** and **103b** and **103c** and **103d**) may be provided in place of the MSA **104**, as shown in **FIG. 19** and **FIG. 20**. In this case, the **103a** and **103c** are placed in a direction orthogonal to each other and the **103b** and **103d** are placed in a direction orthogonal to each other, whereby the directivity can be improved. In this case, the hooks **116a** and **116c** are connected to ends of the loop antenna parts **103b** and **103c** and the hooks **116d** and **116b**

are connected to the transmission section 110 of the electric circuitry 111. Opposite ends of the loop antenna parts 103b and 103c are connected to the transmission section 110 of the electric circuitry 111.

Fifth Embodiment

[0113] FIG. 21 to FIG. 24 show a configuration example of a fifth embodiment of the invention and FIG. 25 to FIG. 27 show a configuration example of a sixth embodiment of the invention. Parts identical with or similar to those previously described with reference to FIG. 14 to FIG. 16 are denoted by the same reference numerals in FIG. 21 to FIG. 27 and will not be discussed again in detail.

[0114] FIG. 21 is a block diagram to show a configuration example of the fifth embodiment of the invention. FIG. 22 is an exploded perspective view to show a specific configuration example of a living body placement section in FIG. 21. FIG. 23 is an external perspective view of the living body placement section shown in FIG. 22 and a transmitter placed thereon. FIG. 24 is a schematic representation to show placement of antennas when the transmitter in FIG. 23 is placed on the living body placement section.

[0115] The embodiment is characterized by the fact that one antenna 603 of two antennas 603 and 604 is divided into two parts, that one antenna division part 603a, an electrode 105, and the whole antenna 604 are placed on a support 102, and that the other antenna division part 603b is placed in a transmitter 106, as shown in FIG. 21. In the embodiment, one electrode 105 is used and a connector 151 placed on another part of a living body is connected to an amplification section 107 through a connector 152, but two or more electrodes 105 may be used. In the embodiment, the antennas 603 and 604 are MSAs, one antenna 603 is divided into two parts, and only the radiation plate 603b of the divided antenna 603 is placed in the transmitter 106.

[0116] In FIG. 22, a radiation plate 604b like a semi-disk is fixed to the upper face of the support 102 formed of a dielectric material like a disk and a base plate 153 like a disk is fixed to the lower face of the support 102 concentrically. A caulking device 154 is inserted into the radiation plate 604b of the MSA 604 from the lower face thereof and a hook 155 for the radiation plate is fixed to the upper end of the caulking device 154 projecting from the radiation plate 604b by caulking.

[0117] A caulking device 156 is inserted into the base plate 153 from the lower face thereof and passes through the support 102 and projects upward. A hook 118 for the ground plate is fixed to the projection end by the caulking. The electrode 105 is inserted into the center of the support 102 from the lower face thereof and passes through the support 102 and projects upward. A hook 120 for deriving an electrocardiographic signal is fixed to the projection end by the caulking. Further, conductive water-containing gel 121 is attached to the lower end of the electrode 105.

[0118] The upper face of the support 102 is covered with a disk-like insulating sheet 157 and the hooks 118, 120, and 155 pass through the insulating sheet 157 and project upward. Likewise, the lower face of the support 102 is covered with a disk-like insulating sheet 122 and the electrode 105 and the water-containing gel 121 pass through openings 153a and 122a made in the centers of the base plate 153 and the insulating sheet 122 and project downward.

[0119] On the other hand, the radiation plate 603b is placed in the transmitter 106. When the transmitter 106 is placed on the support 102 through the hooks 118, 120, and 155, the radiation plate 603b is opposed to the base plate 153 placed on the support 102, forming one MSA 603. Since the radiation plate 604b and the base plate 153 are opposed to each other on the support 102, another MSA 604 is formed on the support 102. The two MSAs 603 and 604 share the base plate 153, as shown in FIG. 24.

[0120] According to the embodiment, functions and advantages almost similar to those of the fourth embodiment can be provided. In the fifth embodiment, one electrode 105 is installed in a living body placement section 101, but if two electrodes 105 are installed, they are placed in a similar manner to that shown in FIG. 15.

Sixth Embodiment

[0121] FIG. 25 is a block diagram to show a configuration example of the sixth embodiment of the invention. FIG. 26 is an exploded perspective view to show a specific configuration example of a living body placement section in FIG. 26. FIG. 27 is an external perspective view of the living body placement section shown in FIG. 26 and a transmitter placed thereon.

[0122] The embodiment basically has almost the same configuration as the fifth embodiment except that an antenna 103 not divided into two parts is placed in a transmitter 106 as shown in FIG. 25 or that two electrodes 105 are provided. The number of the electrodes 105 may be one.

[0123] In FIG. 26 and FIG. 27, the antenna 103 is a loop antenna, an antenna 104 is an MSA, the loop antenna 103 is placed in the transmitter 106, and a base plate 104a and a radiation plate 104b of the MSA 104 are placed in a living body placement section 101 and the transmitter 106 respectively. The attachment structure of the base plate 104a, the electrodes 105, and an insulating plate 122 is similar to that in the fourth embodiment shown in FIG. 15. When the transmitter 106 is placed on the living body placement section 101, the base plate 104a and the radiation plate 104b are opposed to each other, forming the MSA 104.

[0124] According to the embodiment, functions and advantages almost similar to those of the fourth embodiment can be provided. In the sixth embodiment, the number of the electrodes 105 is two, but if one electrode 105 is used, it is placed in a similar manner to that shown in FIG. 22.

Seventh Embodiment

[0125] A seventh embodiment of the invention will be discussed. FIG. 28 is a block diagram to show a configuration example of the seventh embodiment of the invention. FIG. 29 is an exploded perspective view. In the embodiment, two loop antennas 103A and 103B and an MSA 104 are attached to a transmitter 106.

[0126] As shown in FIG. 28, a living body placement section 101 comprises a pair of electrodes 105a and 105b integrally mounted on a support 102. The transmitter 5 contains electric circuitry 111 made up of an amplification section 107, a modulation section 108, a power supply section 109, and a transmission section 110. The loop antennas 103A and 103B and the MSA 104 are electrically connected to the electric circuitry 111. The amplification

section 107 and the electrodes 105 are connected electrically and mechanically through connectors 112.

[0127] Power is supplied from the power supply section 109 to the amplification section 107, the modulation section 108, and the transmission section 110. When the support 102 is placed on the living body surface of a subject, biological signals detected on the electrodes 105a and 105b are amplified by the amplification section 107 and are modulated by the modulation section 108, then are sent from the transmission section 109 to the loop antennas 103A and 103B and the MSA 104. The biological signals are transmitted by radio from the antennas 103A, 103B, and 104 to a receiver (not shown).

[0128] As shown in FIG. 29, a board 731 is housed in a cabinet 773 consisting of an upper lid 773a and a lower lid 773b. The two loop antennas 103A and 103B are installed so that their loop opening faces are orthogonal to the board face of the board 731 and are orthogonal to each other. The two loop antennas 103A and 103B are placed in the proximity of the margins of the board 731 and are connected to the electric circuitry 111.

[0129] The board 731 is provided with lands 732a and 732b for guiding biological signals detected from water-containing gels 718a and 718b and transferred through conductive terminals 718c and 718d, caulking devices 731a and 731b, and convex hooks 719a and 719b into the electric circuitry 111. The board 731 is fixed to the lower lid 773b in parallel with the bottom face thereof by means of caulking devices 733a and 733b inserted into holes made in the centers of the lands 732a and 732b and holes made in projections of the inside of the lower lid 773b from above and concave hooks 734a and 734b corresponding to the caulking devices 733a and 733b. When the apparatus is placed on a living body, the bottom face of the lower lid 773b becomes almost parallel with the living body surface, so that the opening faces of the two loop antennas 103A and 103B become almost orthogonal to the living body surface.

[0130] Further, the MSA 104 consisting of a radiation plate 104b and a base plate 104a placed in parallel on a dielectric support member 735 is installed on the board 731. As described above, the board 731 is fixed to the lower lid 773b in parallel with the bottom face thereof. Thus, when the apparatus is placed on a living body, the radiation plate 104b and the base plate 104a become almost parallel with the living body surface. At this time, the base plate 104a is nearer to the lower lid 773b side than the radiation plate 104b is, and thus is nearer to the living body surface than the radiation plate 104b is.

[0131] A battery storage section is provided in the rear face of the board 731 and a battery 734 is stored in the battery storage section.

[0132] The support 102 is formed of an insulating material like a plate and is narrow at the center. Projections of the caulking devices 731a and 731b are inserted into the holes made in ends of the conductive terminals 718c and 718d placed on the lower face of the support 102 and are fixed to the support 102 together with the conductive terminals 718c and 718d by means of the convex hooks 719a and 719b. The conductive water-containing gels 718a and 718b are attached to the opposite ends of the conductive terminals 718c and 718d. Insulating sheets 720a and 720b are attached to the bottom faces of the caulking devices 731a and 731b for electrically insulating from a living body.

[0133] The structures and materials of the members in the embodiment are almost similar to those of the corresponding members used with the above-described embodiments.

[0134] According to the embodiment, the two loop antennas 103A and 103B, which are orthogonal to each other, are excellent in directivity, and since the opening faces of the loop antennas 103A and 103B are orthogonal to the living body surface, the sensitivity improves and the gain can be increased. In addition, all the antennas 103A, 103B, and 104 are contained in the transmitter, thus the living body placement section 101 can be removed from the transmitter 106 so that only the living body placement section 101 can be made disposable; costs for use can be reduced.

[0135] FIG. 31(a) shows radio wave directivity of a loop antenna 1001 and a monopole antenna 1002, affected by a human body. As shown here, when the opening face of the loop antenna is placed at right angles to the surface of a human body, remarkably excellent directivity is provided as compared with the case where the monopole antenna is placed in roughly parallel with the surface of the human body. FIG. 31(b) is side view of the arrangement of the loop antenna and the monopole antenna attached with the human body along with FIG. 31(a). FIG. 32(a) is an illustration to show directivity provided when the opening face of one loop antenna 1001 is placed at right angles to the surface of a human body. FIG. 32(b) is side view of the arrangement of one loop antenna attached with the human body along with FIG. 32(a). FIG. 33(a) is an illustration to show directivity provided when the opening faces of two loop antennas 1001 are placed at right angles to the surface of a human body and are orthogonal to each other. FIG. 33(b) is side view of the arrangement of two loop antennas attached with the human body along with FIG. 33(a). As shown here, if two loop antennas 1001 are provided, they make a complement to each other in directivity and are less affected by the human body.

[0136] According to the biological signal transmission apparatus of the present invention, when the apparatus is placed on a living body, it can be placed so that the loop opening face of the loop antenna becomes almost at right angles to the living body surface. Thus, the loop opening face can hold a constant direction relative to the living body surface and the human body, etc., does not block the opening face, so that attenuation of radio waves because of the effect of the human body can be lessened, the gain can be improved, and stable directivity can be provided.

[0137] According to the biological signal transmission apparatus of the present invention, when the apparatus is placed on a living body, the loop opening faces of the two loop antennas become almost at right angles to the living body surface and are placed in a direction almost perpendicular to each other. Thus, the loop antennas make a complement to each other in directivity and the gain can be improved.

[0138] According to the biological signal transmission apparatus of the present invention, at least one loop antenna is contained in the transmitter, thus the person on whom the apparatus is placed is not restrained as compared with an antenna placed on the outside such as a monopole antenna ($\lambda/4$ antenna). The manufacturing cost of the support supporting the electrode and placed on the living body surface can be reduced and can be made disposable.

[0139] According to the biological signal transmission apparatus of the present invention, at least one of the loop antennas is divided into two parts, one loop antenna division part is placed in the support and the other is placed in the transmitter, and the transmitter is placed on the support, thereby putting the loop antenna division parts into one

piece. Thus, the transmitter can be miniaturized or the loop opening face can be enlarged as compared with the case where all loop antennas are installed in the transmitter. Since the loop antenna is closely fixed in the proximity of a living body with the opening face orthogonal to the living body surface, the gain is also improved.

[0140] According to the biological signal transmission apparatus of the present invention, the loop antenna for emitting a biological signal is integral with the support supporting the electrode, on which the transmitter is placed, and when the support is placed on the living body surface, the opening face of the loop antenna becomes almost at right angles to the living body surface, thus attenuation of radio waves of the loop antenna can be lessened and the gain can be improved.

[0141] According to the biological signal transmission apparatus of the present invention, the loop antenna disposed so that the opening face is placed in a direction almost perpendicular to the living body surface, and the microstrip antenna having a radiation plate and a base plate opposed in parallel with the living body surface, the base plate being placed nearer to the living body surface, are placed, so that attenuation of radio waves because of the effect of the human body can be lessened and the two antennas make a complement to each other in directivity, thus the gain can be improved.

[0142] According to the biological signal transmission apparatus of the present invention, the two loop antennas disposed so that the opening faces are placed in a direction almost perpendicular to the living body surface and are almost at right angles to each other, and a microstrip antenna having a radiation plate and a base plate opposed in parallel with the living body surface, the base plate being placed nearer to the living body surface, are provided, so that the three antennas make a complement to each other in directivity and the gain can be improved.

[0143] According to the biological signal transmission apparatus of the present invention, at least one of the loop antennas and the microstrip antenna is contained in the transmitter, so that the person on whom the apparatus is placed is not restrained as compared with a monopole antenna, etc., placed on the outside. Further, the manufacturing cost of the support supporting the electrode and placed on the living body surface can be reduced.

[0144] According to the biological signal transmission apparatus of the present invention, the loop antenna or the microstrip antenna can be placed on the support occupying a larger area than the transmitter, so that the loop opening area of the loop antenna can be enlarged and the areas of the radiation plate and the base plate of the microstrip antenna can be made large. Thus, the gain and band width can be improved.

[0145] According to the biological signal transmission apparatus of the present invention, the microstrip antenna having a radiation plate and a base plate opposed in parallel with the living body surface, the base plate being placed nearer to the living body surface, is provided, so that the microstrip antenna placed in parallel with the living body surface can be thinned and a large projection such as a monopole antenna is removed from the living body surface.

Since the base plate is placed between the radiation plate and the living body surface, the antenna performance is less affected by the living body.

[0146] According to the biological signal transmission apparatus of the present invention, the microstrip antenna is contained in the transmitter, whereby the patient is not restrained as compared with an antenna placed on the outside such as a monopole antenna. Further, the manufacturing cost of the support supporting the electrode and placed on the living body surface can be reduced.

[0147] According to the biological signal transmission apparatus of the present invention, the microstrip antenna is integral with the support and is connected to output of the electric circuitry through a connection member and the transmitter is placed on the support. Thus, the radiation plate and the base plate can be placed on the support occupying a larger area than the transmitter, so that they can be formed largely and the gain and band width can be improved.

[0148] According to positioning of biological signal transmission apparatus of the present invention, ECG wave which is highly correlative to ECG detected in the method of standard limb lead (II) can be obtained by positioning two electrodes in the vicinity of first and second intercostal space left sternal border parallel to clavicle on a left chest or at area defined between a xiphoid process and a navel perpendicular to a midsternal line on a chest that help diagnosis of ECG wave easily.

What is claimed is:

1. A method of detecting a ECG wave of a subject, comprising:

(a) positioning two electrodes within 2.5 cm of an area defined between a xiphoid process and a navel perpendicular to a midsternal line; and

(b) detecting a ECG wave from signals from said two electrodes according to a standard limb lead method.

2. A method according to claim 1, wherein said electrodes are spaced from each other within a range of 1 to 7.5 cm.

3. A method according to claim 1, wherein said electrodes are spaced from each other in a range of 2 to 7.5

4. A method of detecting a ECG wave of a subject, using a ECG signal transmission apparatus which comprises: two electrodes for detecting a ECG signal; a support for supporting said electrodes, said support operative to be placed on a living body; a transmitter having an electric circuit for processing the ECG signal detected on said electrodes; said method comprising:

(a) positioning said two electrodes at an area defined between a xiphoid process and a navel perpendicular to a midsternal line; and

(b) detecting a ECG wave from signals from said two electrodes according to a standard limb lead method.

5. A method according to claim 4, wherein said electrodes are spaced from each other within a range of 1 to 7.5 cm.

6. A method according to claim 4, wherein said electrodes are spaced from each other within a range of 2 to 7.5 cm.

* * * * *

专利名称(译)	生物信号传输装置		
公开(公告)号	US20020107453A1	公开(公告)日	2002-08-08
申请号	US10/113558	申请日	2002-04-02
[标]申请(专利权)人(译)	日本光电工业株式会社		
申请(专利权)人(译)	日本光电公司		
当前申请(专利权)人(译)	日本光电公司		
[标]发明人	MATSUMURA FUMIYUKI SEKIGUCHI TETSUSHI SAKATA HIROSHI HOSAKA HIDEHIRO		
发明人	MATSUMURA, FUMIYUKI SEKIGUCHI, TETSUSHI SAKATA, HIROSHI HOSAKA, HIDEHIRO		
IPC分类号	A61B5/00 A61B5/0404 A61B5/0408 A61B5/0432 A61B5/04		
CPC分类号	A61B5/0006 A61B5/0008 A61B5/0404 A61B5/04085 A61B5/04325 A61B2560/0412 A61B2560/045 A61B2560/0475 Y10S128/903		
优先权	1997359933 1997-12-26 JP 1997358536 1997-12-25 JP		
其他公开文献	US7089048		
外部链接	Espacenet USPTO		

摘要(译)

用于检测生物信号的电极4和环形天线3一体地安装在放置在活体表面上的支撑件2上，发射器5放置在支撑件2上。在电极4上检测到的生物信号通过连接器11连接到发射器5的电路10，并且由电路10处理的电信号通过连接器12和13输出到环形天线3的两端，生物信号从该端部发射到接收器。此时，环形天线3的开口面在几乎垂直于活体表面的方向上，以提高灵敏度。

