



US009310257B2

(12) **United States Patent**  
**Bieberich et al.**

(10) **Patent No.:** **US 9,310,257 B2**  
(45) **Date of Patent:** **Apr. 12, 2016**

(54) **DEEP TISSUE TEMPERATURE PROBE CONSTRUCTIONS**

(75) Inventors: **Mark T. Bieberich**, Edina, MN (US);  
**Albert P. Van Duren**, Chaska, MN (US)

(73) Assignee: **3M INNOVATIVE PROPERTIES COMPANY**, St. Paul, MN (US)

(\*) Notice: Subject to any disclaimer, the term of this patent is extended or adjusted under 35 U.S.C. 154(b) by 1000 days.

(21) Appl. No.: **12/798,945**

(22) Filed: **Apr. 14, 2010**

(65) **Prior Publication Data**

US 2010/0268113 A1 Oct. 21, 2010

**Related U.S. Application Data**

(60) Provisional application No. 61/212,749, filed on Apr. 15, 2009.

(51) **Int. Cl.**

**A61B 19/00** (2006.01)  
**G01K 1/16** (2006.01)  
**A61B 5/01** (2006.01)  
**A61B 5/00** (2006.01)  
**G01K 13/00** (2006.01)

(52) **U.S. Cl.**

CPC . **G01K 1/165** (2013.01); **A61B 5/01** (2013.01);  
**A61B 5/6833** (2013.01); **A61B 5/6843**  
(2013.01); **G01K 1/16** (2013.01); **G01K 13/002**  
(2013.01); **A61B 2562/0271** (2013.01); **A61B**  
**2562/0276** (2013.01); **A61B 2562/164**  
(2013.01)

(58) **Field of Classification Search**

USPC ..... 136/211, 212, 225; 206/306; 374/134,  
374/163, 169, 209, 29, 30, 44; 600/549;  
607/108; 702/131

See application file for complete search history.

(56) **References Cited**

U.S. PATENT DOCUMENTS

1,363,259 A 12/1920 Mills  
1,526,641 A 2/1925 Mulvany et al.  
1,528,383 A 3/1925 Schmidt  
1,638,943 A 8/1927 Little  
2,378,804 A 6/1945 Sparrow et al.  
2,381,819 A 8/1945 Graves et al.  
2,519,785 A 8/1950 Okolicsanyi  
2,629,757 A 2/1953 McKay  
2,807,657 A 9/1957 Jenkins et al. .... 136/4

(Continued)

FOREIGN PATENT DOCUMENTS

CA 2 538 940 A1 6/2006 ..... A61B 5/00  
CA 2 583 034 A1 9/2007 ..... A61B 5/01

(Continued)

OTHER PUBLICATIONS

International Search Report and Written Opinion, PCT/US2011/000549, mailed Jun. 26, 2011.

(Continued)

*Primary Examiner* — Sean Dougherty

(74) *Attorney, Agent, or Firm* — X. Christina Huang

(57) **ABSTRACT**

Disposable, zero-heat-flux, deep tissue temperature probes are constructed using a support assembly constituted of a flexible substrate that supports elements of the probe. One support assembly embodiment includes a folded substrate with a heater and thermal sensors disposed on it. Another support assembly includes multiple sections separable into strata supporting a covering guard heater, a central thermal sensor, and a thermal sensor displaced at least radially from the central thermal sensor.

**9 Claims, 5 Drawing Sheets**

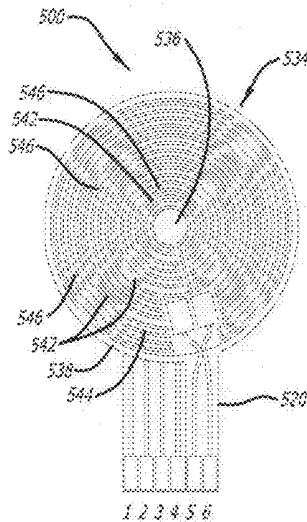

(56)

## References Cited

## U.S. PATENT DOCUMENTS

2,969,141 A	1/1961	Katzin	206/16.5	6,255,622 B1	7/2001	May et al.	219/209
3,099,575 A	7/1963	Hill	117/212	6,278,051 B1	8/2001	Peabody	136/225
3,099,923 A	8/1963	Benzinger	73/341	6,280,397 B1	8/2001	Yarden et al.	600/549
3,215,265 A	11/1965	Welin-Berger	206/63.2	6,283,632 B1	9/2001	Takaki	374/161
3,235,063 A	2/1966	Jarund	206/16.5	6,292,685 B1	9/2001	Pompei	600/474
3,238,775 A	3/1966	Watts	73/190	6,300,554 B1 *	10/2001	Du et al.	136/201
3,301,394 A	1/1967	Baermann et al.	206/63.2	6,312,391 B1	11/2001	Ramadhyan et al.	600/549
3,367,182 A	2/1968	Baxter	73/190	6,355,916 B1	3/2002	Siefert	219/494
3,427,209 A	2/1969	Hager, Jr.	136/225	6,377,848 B1	4/2002	Garde et al.	604/20
3,469,685 A	9/1969	Baermann	206/63.2	6,398,727 B1	6/2002	Bui et al.	600/300
3,552,558 A	1/1971	Poncy	206/63.2	6,495,806 B2	12/2002	Siefert	219/494
3,581,570 A	6/1971	Wortz	73/355 R	6,553,243 B2	4/2003	Gurley	600/340
3,607,445 A	9/1971	Hines	136/225	6,595,929 B2	7/2003	Stivoric et al.	600/549
3,720,103 A	3/1973	Adams et al.	73/190 H	6,626,037 B1 *	9/2003	Wado	G01F 1/6845 73/204.11
3,767,470 A	10/1973	Hines	136/225	6,676,287 B1	1/2004	Mathis et al.	374/1
3,781,749 A	12/1973	Iles et al.	338/25	6,773,405 B2	8/2004	Fraden et al.	600/549
3,809,230 A	5/1974	Poncy	206/306	6,827,487 B2	12/2004	Baumbach	374/164
3,833,115 A	9/1974	Schapker	206/63.2	6,886,978 B2	5/2005	Tokita et al.	374/169
3,877,463 A	4/1975	Cary et al.	128/2 H	6,929,611 B2	8/2005	Koch	600/549
3,933,045 A	1/1976	Fox et al.	73/359	7,059,767 B2	6/2006	Tokita et al.	374/163
3,942,123 A	3/1976	Georgi	328/1	7,270,476 B2	9/2007	Tokita et al.	374/107
4,022,063 A	5/1977	West et al.	73/362	7,276,076 B2 *	10/2007	Bieberich	607/108
4,024,312 A	5/1977	Korpman	428/343	7,299,090 B2	11/2007	Koch	600/547
4,142,631 A	3/1979	Brandriff	206/306	7,306,283 B2	12/2007	Howick et al.	297/180.12
4,190,058 A	2/1980	Sagi		7,318,004 B2	1/2008	Butterfield	702/130
4,253,469 A	3/1981	Aslan	128/736	7,354,195 B2	4/2008	Sakano	374/208
4,275,741 A	6/1981	Edrich	128/653	7,364,356 B2	4/2008	Dicks et al.	374/121
4,347,854 A	9/1982	Gosline et al.	128/736	7,410,291 B2	8/2008	Koch	374/163
4,407,292 A	10/1983	Edrich	128/653	7,426,872 B2	9/2008	Dittmar et al.	73/818
4,494,550 A	1/1985	Blazek et al.	128/664	7,470,280 B2 *	12/2008	Bieberich	607/104
4,539,994 A	9/1985	Baumbach et al.	128/635	8,025,690 B2 *	9/2011	Bieberich	607/108
4,541,734 A	9/1985	Ishizaka	374/169	8,123,790 B2 *	2/2012	Bieberich	607/107
4,572,213 A	2/1986	Kawahara	128/736	8,123,792 B2 *	2/2012	Bieberich	607/108
4,574,359 A	3/1986	Ishizaka et al.	364/557	8,226,294 B2 *	7/2012	Bieberich et al.	374/163
4,577,976 A	3/1986	Hayashi et al.	374/29	8,292,495 B2 *	10/2012	Bieberich et al.	374/1
4,592,000 A	5/1986	Ishizaka et al.	364/557	8,292,502 B2 *	10/2012	Bieberich et al.	374/163
4,629,336 A	12/1986	Ishizaka	364/557	2002/0097775 A1	7/2002	Hamouda et al.	374/29
4,648,055 A	3/1987	Ishizaka et al.	364/557	2003/0130590 A1	7/2003	Bui et al.	600/537
4,652,145 A	3/1987	Bjornberg	374/194	2004/0210280 A1	10/2004	Liedtke	607/96
4,669,049 A	5/1987	Kosednar et al.	364/557	2005/0245839 A1	11/2005	Stivoric et al.	600/549
4,747,413 A	5/1988	Bloch	128/736	2007/0167859 A1	7/2007	Finneran et al.	600/546
4,841,543 A	6/1989	Dittmar et al.	374/44	2007/0206655 A1	9/2007	Haslett et al.	374/141
4,859,078 A	8/1989	Bowman et al.	374/44	2007/0282218 A1	12/2007	Yarden	600/549
4,899,297 A	2/1990	Sano et al.	364/557	2008/0170600 A1	7/2008	Sattler et al.	374/163
4,955,380 A	9/1990	Edell	128/635	2008/0264166 A1 *	10/2008	Wienand	G01F 1/6845 73/204.26
4,987,579 A	1/1991	Yoshinaka et al.	377/25	2009/0129433 A1	5/2009	Zhang et al.	374/102
5,002,057 A	3/1991	Brady	128/652	2010/0121217 A1 *	5/2010	Padiy et al.	600/549
5,015,102 A	5/1991	Yamaguchi	374/107	2010/0292605 A1	11/2010	Grassl et al.	600/549
5,033,866 A	7/1991	Kehl et al.	374/179	2011/0051776 A1 *	3/2011	Bieberich et al.	374/163
5,040,901 A	8/1991	Suzuki	374/183	2011/0249699 A1 *	10/2011	Bieberich et al.	374/1
5,050,612 A	9/1991	Matsumura	128/670	2011/0249701 A1 *	10/2011	Bieberich et al.	374/163
5,062,432 A	11/1991	James et al.	128/736	2012/0289855 A1 *	11/2012	Bieberich et al.	600/549
5,088,837 A	2/1992	Shiokawa et al.	374/185	2013/0010828 A1 *	1/2013	Bieberich et al.	374/163
5,149,200 A	9/1992	Shiokawa et al.	374/185				
5,172,979 A	12/1992	Barkley et al.	374/147				
5,178,468 A	1/1993	Shiokawa et al.	374/185				
5,199,436 A	4/1993	Pompei et al.	128/664				
5,255,979 A	10/1993	Ferrari	374/158				
5,263,775 A	11/1993	Smith et al.	374/134				
5,293,877 A	3/1994	O'Hara et al.	128/736				
5,483,190 A	1/1996	McGivern	327/34				
5,516,581 A	5/1996	Kreckel et al.	428/317.3				
5,816,706 A	10/1998	Heikkila et al.	374/134				
5,884,235 A	3/1999	Ebert	702/87				
5,990,412 A	11/1999	Terrell	136/225				
5,993,698 A	11/1999	Frentzel et al.	252/511				
6,001,471 A	12/1999	Bries et al.	428/343				
6,014,890 A	1/2000	Breen	73/29.02				
6,019,507 A	2/2000	Takaki	374/161				
6,059,452 A	5/2000	Smith et al.	374/169				
6,203,191 B1	3/2001	Mongan	374/43				
6,220,750 B1	4/2001	Palti	374/164				
6,224,543 B1	5/2001	Gammons et al.	600/124				
6,231,962 B1	5/2001	Bries et al.	428/317.3				
6,253,098 B1	6/2001	Walker et al.	600/344				

## FOREIGN PATENT DOCUMENTS

DE	3527942 A1	2/1987	G01K 7/00
EP	0239824 B1	5/1992	G01K 13/00
GB	2266771 A	11/1993	G01K 1/18
JP	55-29794	3/1980	G01K 1/16
JP	57-183832	12/1982	A61B 5/00
JP	08-211000	8/1996	G01N 25/00
JP	2002202205 A	7/2002	G01K 7/00
JP	2007-212407 A	8/2007	A61B 5/01
JP	2009-080000 A	4/2009	A61B 5/04
WO	WO 99/60356 A1	11/1999	G01K 17/00
WO	WO 00/58702 A1	10/2000	G01K 7/02
WO	WO 01/31305 A1	5/2001	G01K 7/42
WO	WO 02/066946 A2	8/2002	G01K 13/00
WO	WO 2007/060609 A2	5/2007	A61B 5/0408
WO	WO 2008/068665 A1	6/2008	G01K 1/16
WO	WO 2008068665 A1 *	6/2008	G01K 1/16
WO	WO 2008/078271 A1	7/2008	G01K 1/16
WO	WO 2009/141780 A1	11/2009	G01K 1/16
WO	WO 2010/082102 A2	7/2010	G01K 1/14
WO	WO 2010/103436 A1	9/2010	G01K 1/16
WO	WO 2010/116297 A1	10/2010	G01K 1/14

(56)

## References Cited

## FOREIGN PATENT DOCUMENTS

WO WO 2010/120360 A1 10/2010 ..... G01K 13/00  
 WO WO 2010/120362 A1 10/2010 ..... G01K 13/00  
 WO WO 2011/025521 A1 10/2010  
 WO WO 2011/126543 A1 10/2011  
 WO WO 2011/146098 A1 11/2011

## OTHER PUBLICATIONS

International Search Report and Written Opinion, PCT/US2011/000552, mailed Jun. 29, 2011.

Fox RH, et al, A new technique for monitoring the deep body temperature in man from the intact skin surface. *J. Physiol.* 1971; 212(2): 8P-10P.

Solman AJ, et al, New thermometers for deep tissue temperature. *Biomedical Engineering* 1973; 8(10): 432-435.

Fox RH, et al, A new method for monitoring deep body temperature from the skin surface. *Clin. Sci.* 1973; 44: 81-86.

Togawa, T, et al, A modified internal temperature measurement device, *Medical and Biological Engineering*, May 1976, pp. 361-364.

Togawa T, Non-invasive deep body temperature measurement. In: Rolfé P (ed) *Non-invasive Physiological Measurements*. 1979; vol. 1: 261-277.

Zhang X, et al, Application of the Heat Flux Meter in Physiological Studies, *J. therm. Biol.*, 1993, vol. 18: 473-476. Yamakage M, et al,

Deep temperature monitoring-comparative study between conventional and new developed monitors, *Anesthesiology*, 2002; 96: A501. Suleman M-I, et al, Insufficiency in a new temporal-artery thermometer for adult and pediatric patients, *Anesth Analg*, 2002; 95: 67-71. Yamakage M, Evaluation of a newly developed monitor of deep body temperature, *J. Anesth.*, 2002; 16:354-357.

Thurbide, K., Excuse me, but my Band-Aid is beeping, Haslett's smart Band-Aid/University of Calgary, Jul. 18, 2007, pp. 1-2.

Gunga H-C, et al, A non-invasive device to continuously determine heat strain in humans. *J. Ther. Bio.* 2008; 33: 297-307.

Kimberger O, Accuracy and precision of a novel non-invasive core thermometer. *BJA*. 2009; 103(2): 226-231.

Langham GE, et al, Noninvasive temperature monitoring in postanesthesia care units, *Anesthesiology*, 2009, 111; 1:1-7.

Kitamura, K, et al, Development of a new method for the noninvasive measurement of deep body temperature without a heater, *Med. Eng. Phys.*, 2010; 32(1): 1-6. Epub Nov. 10, 2009.

Zeiner A, et al, Non-invasive continuous cerebral temperature monitoring in patients treated with mild therapeutic hypothermia: an observational pilot study, *Resuscitation*, Jul. 2010; 81(7) 861-866. Epub Apr. 15, 2010.

International Search Report and Written Opinion, PCT/US2010/001108, mailed Jul. 23, 2010.

International Search Report and Written Opinion, PCT/US2010/001104, mailed Jul. 26, 2010.

International Search Report and Written Opinion, PCT/US2010/002185, mailed Dec. 13, 2010.

\* cited by examiner

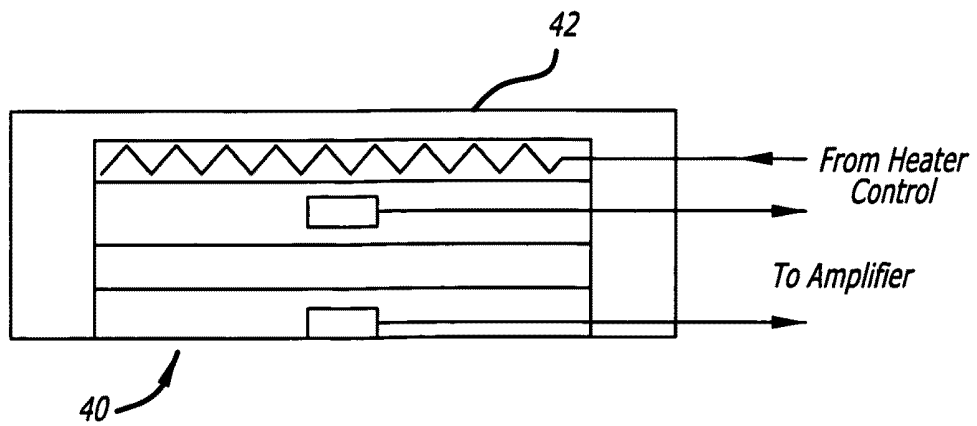
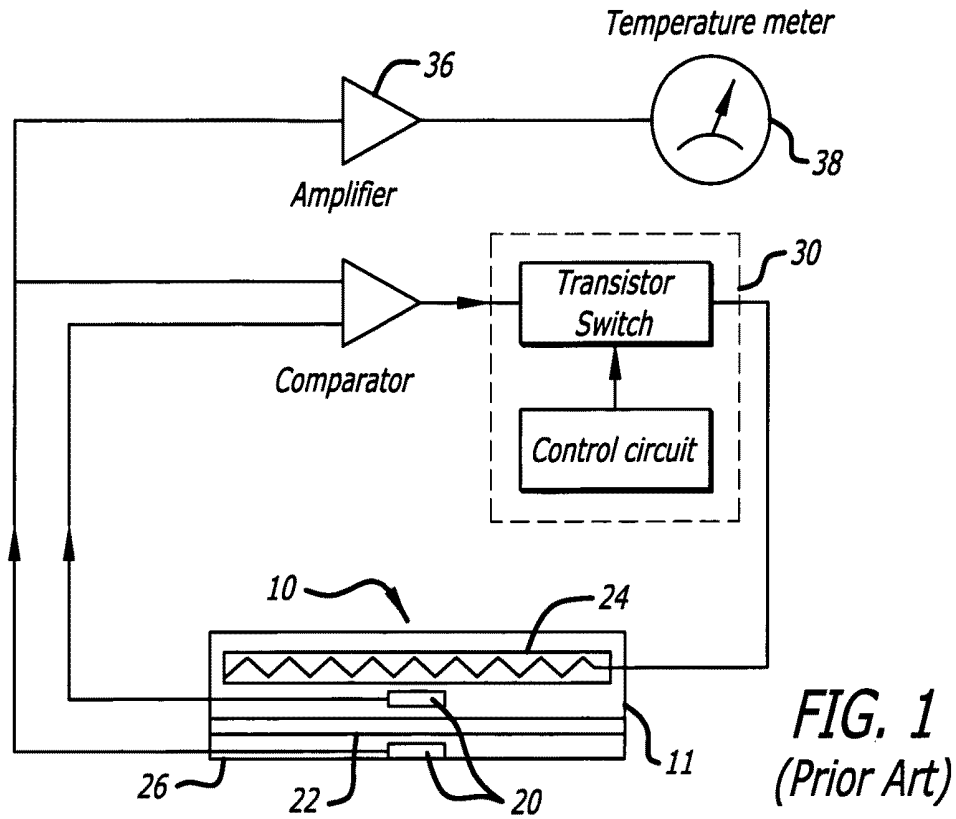

**FIG. 2**  
*(Prior Art)*

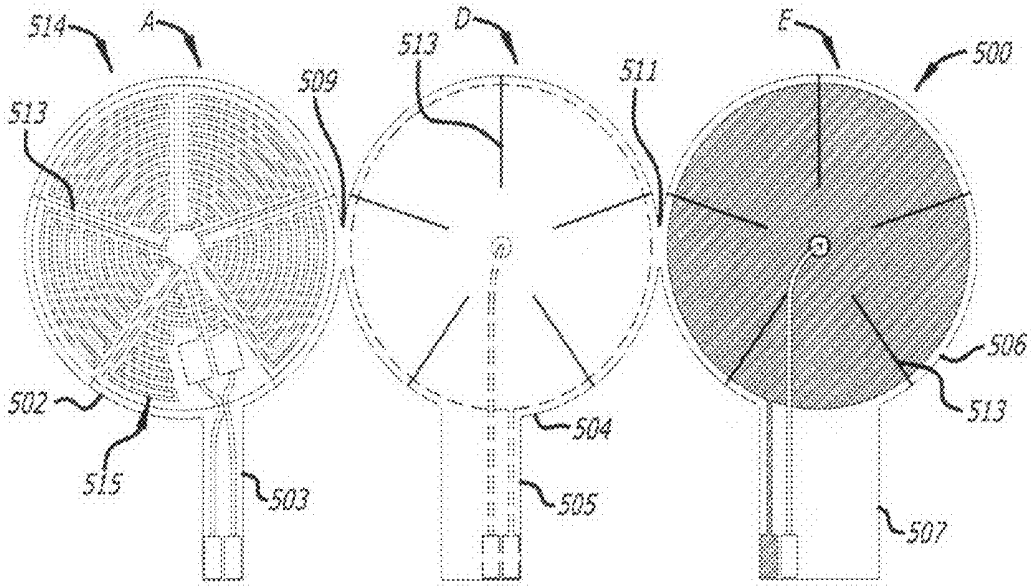

FIG. 3A

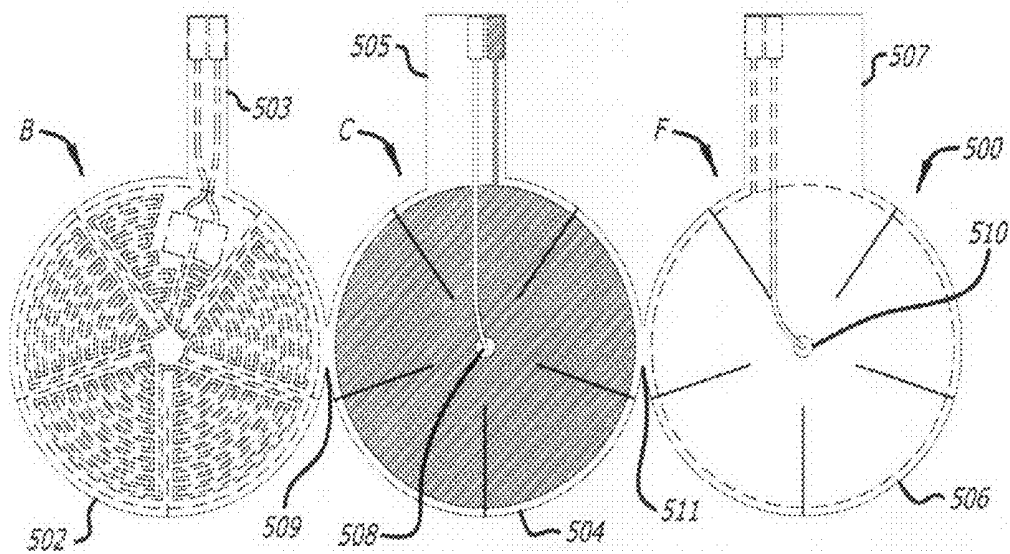

FIG. 3B

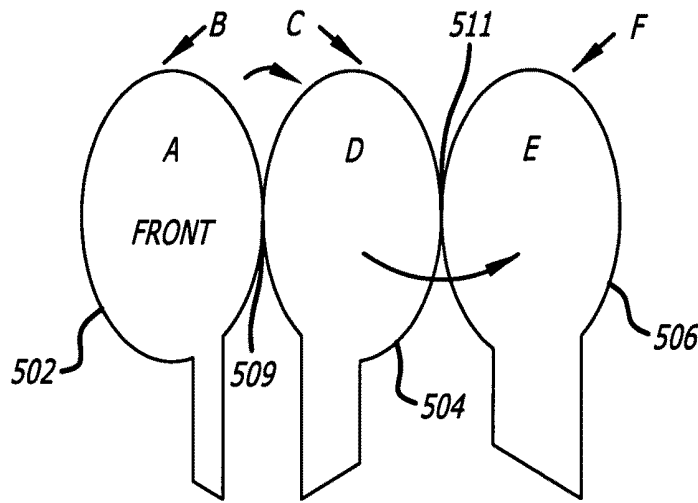

FIG. 3C

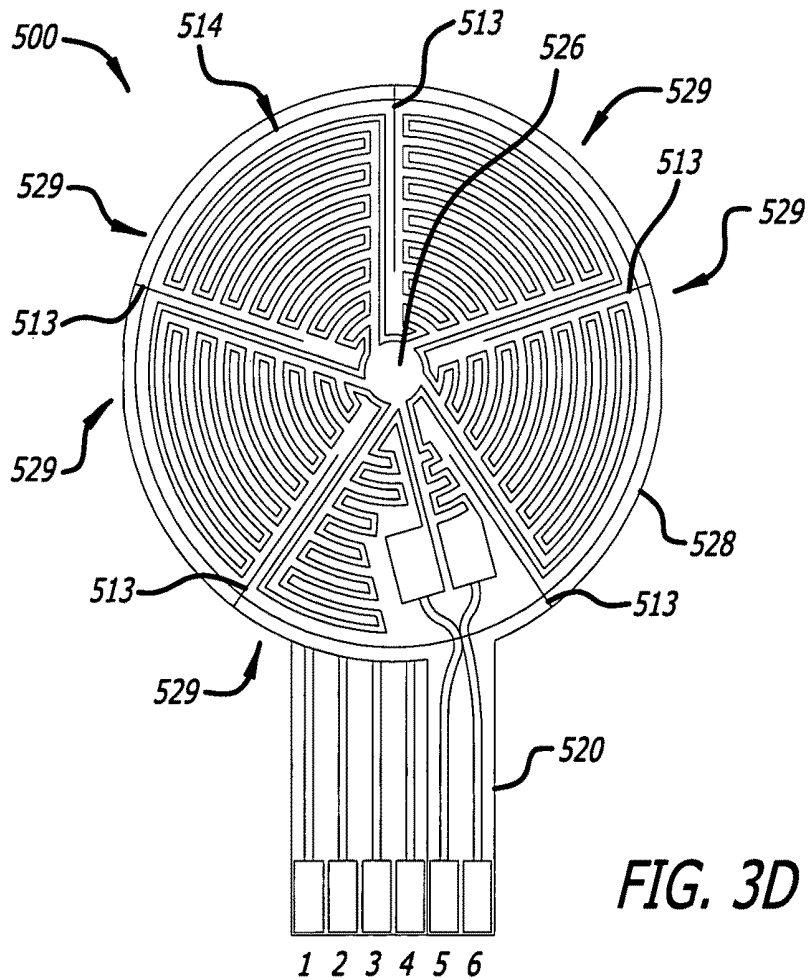

FIG. 3D

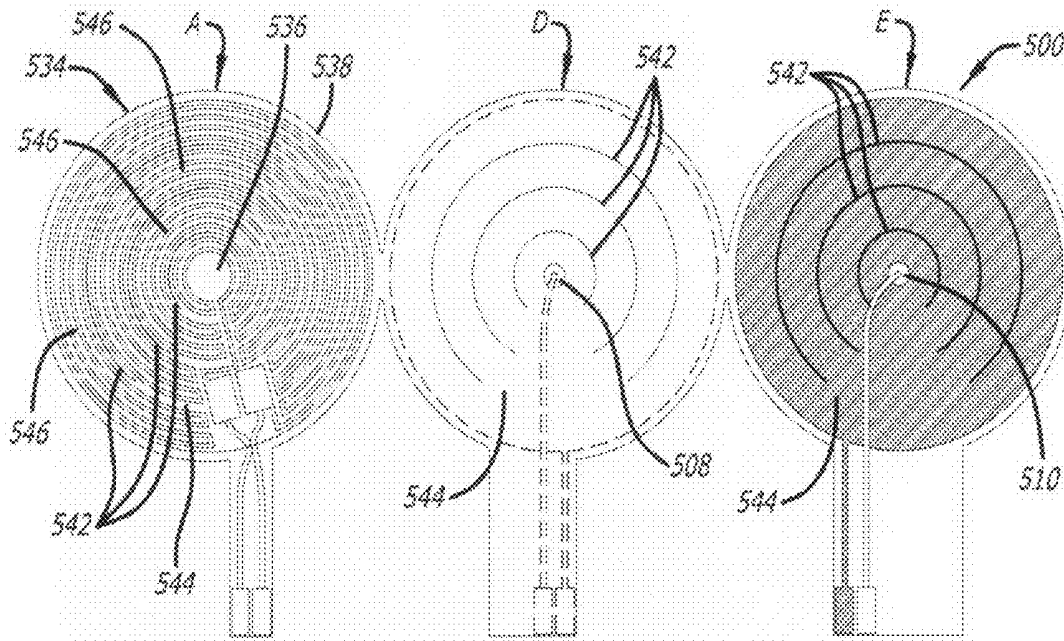

FIG. 3E

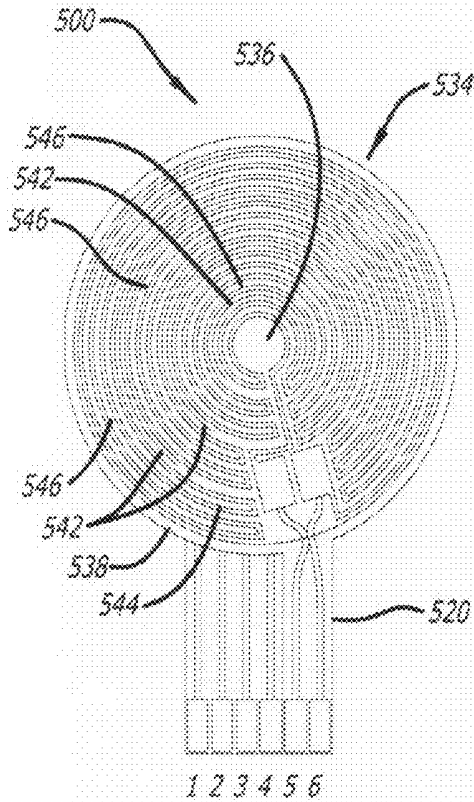

FIG. 3F

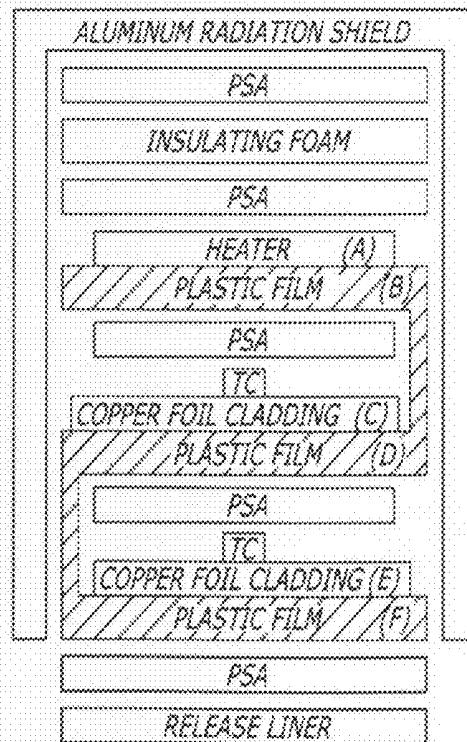

FIG. 4



## DEEP TISSUE TEMPERATURE PROBE CONSTRUCTIONS

### PRIORITY

This application claims priority to U.S. Provisional Application for patent 61/212,749 filed Apr. 15, 2009.

### RELATED APPLICATIONS

This application contains material related to the following US patent applications:

U.S. patent application Ser. No. 12/584,108, filed Aug. 31, 2009.

### BACKGROUND

The subject matter relates to a temperature probe—a device placed on the skin of a subject to measure temperature. More particularly, the subject matter pertains to a deep tissue temperature (DTT) probe. Deep tissue temperature measurement is a non-invasive determination of the core temperature of a human body in which a probe is located over a region of deep tissue that is representative of the body core. The probe reads the temperature of that region as the core temperature.

A system for non-invasively measuring deep tissue temperature was described by Fox and Solman in 1971 (Fox R H, Solman A J. A new technique for monitoring the deep body temperature in man from the intact skin surface. *J. Physiol.* January 1971:212(2): pp 8-10). The system, illustrated in FIG. 1, estimates body core temperature by indirect means using a specially designed probe **10** that stops or blocks heat flow through a portion of the skin. The components of the probe **10** are contained in a housing **11**. The probe **10** includes two thermistors **20** mounted on either side of a thermal resistance **22**, which may be constituted of a layer of insulating material capable of supporting the thermistors **20**. The probe **10** also includes a heater **24** disposed at the top of the probe **10**, over the elements **20**, **22**, and **24**. In use, the probe **10** is placed on a region of skin where deep tissue temperature is to be measured. With the bottom surface **26** of the probe resting on a person's body, in contact with the skin, the thermistors **20** measure a temperature difference, or error signal, across the thermal resistance **22**. The error signal is used to drive a heater controller **30**, which, in turn, operates to minimize the error signal by causing the heater **24** to provide just enough heat to equalize the temperature on both sides of the thermal resistance **22**. When the temperatures sensed by the thermistors **20** are equal, there is no heat flow through the probe, and the temperature measured by the lower thermistor **20** by way of a temperature meter circuit constituted of an amplifier **36** and a temperature meter **38** is equivalent to DTT. The probe **10** essentially acts as a thermal insulator that blocks heat flow through the thermal resistor **22**; DTT probes that operate in the same manner are termed “zero-heat-flux” (“ZHF”) probes. Since the heater **24** operates to guard against loss of heat along the path of measurement through the probe, it is often referred to as a “guard heater”.

Togawa improved the Fox/Solman design with a DTT probe structure that accounted for the strong multi-dimensional heat transfer of dermal blood flow through the skin. (Togawa T. *Non-Invasive Deep Body Temperature Measurement*. In: Rolfe P (ed) *Non-Invasive Physiological Measurements*. Vol. 1. 1979. Academic Press, London, pp. 261-277). The probe, illustrated in FIG. 2, encloses a ZHF sensor design **40**, which blocks heat flow normal to the body, in a thick

aluminum housing **42** with a disk-like construction that also reduces or eliminates radial heat flow from the center to the periphery of the probe.

Both Fox/Solman and Togawa use heat flux normal to the body (and the skin where the probe is placed) to control the operation of a heater that blocks heat flow through a thermal resistance. This results in a construction that stacks probe components, which gives the probe a substantial vertical profile. The thermal mass added by Togawa's probe design also improves the stability of the Fox/Solman design. Basic engineering for heat flux measurement would suggest that a large thermal resistance in the probe makes the measurement more accurate, but also slows the transient response rate. Since the goal is zero heat flux across the gage the more thermal resistance the better. However, additional thermal resistance adds mass and size.

Maintenance of body core temperature in a normothermic range during a perioperative cycle has been shown to reduce the incidence of surgical site infection, and so it is beneficial to monitor a patient's body core temperature before, during, and after surgery. Of course non-invasive measurement is very desirable, for both the comfort and the safety of a patient. Deep tissue temperature measurement using a probe supported on the skin provides an accurate and non-invasive means for monitoring body core temperature. However, the size and mass of the Fox/Solman and Togawa probes do not promote disposability. Consequently, they must be sterilized after each use, and stored for reuse. As a result, use of these probes to measure deep tissue temperature may raise the costs associated with DTT measurement and may increase the risk of cross contamination between patients. It is therefore useful to reduce the size and mass of a DTT probe, without sacrificing its performance, in order to promote disposability.

### SUMMARY

Disposable, zero-heat-flux, deep tissue temperature probes are constructed using an assembly constituted of a flexible substrate that supports elements of the probe. One support assembly embodiment includes a layer with a multi-zone heater, thermal sensors, and a thermal resistor disposed on it. The heater has multiple zones defined by openings formed through the layer, between the zones, to enhance the flexibility of the probe. Another support assembly includes multiple layers supporting a covering guard heater, a central thermal sensor, and a thermal sensor displaced at least radially from the central thermal sensor.

### BRIEF DESCRIPTION OF THE DRAWINGS

FIG. 1 is a schematic block diagram of a first prior art deep tissue temperature measurement system including a ZHF deep tissue temperature probe.

FIG. 2 is a schematic side sectional diagram of a second prior art deep tissue temperature measurement system including a ZHF deep tissue temperature probe with an aluminum cap.

FIGS. 3A-3D illustrate layout and assembly of a first embodiment of a thermal measurement support assembly with a multi-zone heater for a ZHF probe;

FIGS. 3E and 3F illustrate layout and assembly of a second embodiment of a thermal measurement support assembly with a multi-zone heater for a ZHF probe.

FIG. 4 sectional view in elevation showing an assembled DTT probe with the first or second support assembly embodiment.

FIG. 5A is a side sectional view of a third support assembly embodiment.

FIG. 5B is a top plan view of the third support assembly embodiment.

#### DETAILED DESCRIPTION OF THE PREFERRED EMBODIMENTS

It is desirable that zero-heat-flux, deep tissue temperature probe (DTT probe) constructions be disposable. Thus the constructions should be easy and inexpensive to fabricate and assemble, have a low mass and a low profile, and comprise inexpensive materials and parts.

It is particularly desirable that disposable DTT constructions be assembled from low-profile, light weight, flexible assemblies that enable zero-heat-flux measurement at various locations on a human or animal body.

A thermal measurement support assembly for zero-heat-flux deep tissue temperature probe (DTT probe) constructions includes a flexible substrate with at least two thermal sensors disposed in a spaced-apart relationship and separated by one or more layers of thermally insulating material. Preferably the sensors are spaced apart vertically as in FIGS. 1 and 2, and they may further be spaced apart horizontally or radially with respect to a center of measurement of vertical heat flux. The substrate supports at least the thermal sensors and the separating thermal insulating material, and it may also support one or more heaters. Once constructed, the support assembly is ready to be incorporated into the structure of a DTT probe.

Support assembly constructions illustrated in FIGS. 3A and 3B include a plurality of layers to support a heater and thermal sensors. The layers have multiple zones with slits formed through the layers, between the zones, to enhance the flexibility of the probe. The slits enable the zones to flex independently of one another.

As seen in FIGS. 3A and 3B, a support assembly 500 includes a flexible substrate, preferably a sheet of flexible, thermally insulative material that is formed to include a plurality of contiguous sections. For example three contiguous paddle-shaped sections with disks 502, 504, and 506 of equal diameter are formed and aligned so that their centers lie on a straight line. Each disk transitions to a tab for supporting one or more electrical leads. The tabs are indicated by reference numerals 503, 505, and 507, respectively. The inner periphery of each disk is continuous with each adjacent inner periphery at a point that is tangent to the perimeter of the inner circle and which intersects the line upon which the centers are aligned. Thus, the inner periphery of the outer disk 502 is continuous with the periphery of the inner disk 504 at 509, and the inner periphery of the outer disk 506 is continuous with the periphery of the inner disk 504 at 511, which is diametrically opposite 509 on the periphery of the inner disk 504. Each disk has two opposite-facing, disk-shaped major surfaces. Thus, the outer disk 502 has major surfaces A and B, the inner disk 504 has major surfaces C and D, and the outer 506 has surfaces E and F. The major surfaces A, D, and E are on one side of the support assembly 500; the major surfaces B, C, and F are on the opposite side. Each of the sections is divided into a circular array of wedge-shaped zones by a pattern of radial slits 513 that extend from the circumferential periphery toward the center of each disk. The slits 513 extend up to an undivided central portion of each disk. The slit patterns are identical so that the slits of each section align with the slits of the other sections when the sections are folded together.

As seen in FIGS. 3A and 3B, a heater 514 is supported on the major surface A. Preferably, the heater 514 is constituted

of a trace pattern of etched copper which in each wedge-shaped zone contains a corresponding wedge-shaped zone 515 of the heater 514. In order to maximize the thermal capacity of the heater, the heater trace pattern describes a series of switchbacks in each zone, with the connections between zones traversing the un-slitted central portion of the section. The etching includes formation of leads and pins for the heater on the tab 503. The etching also includes formation of rings of exposed insulative material at the peripheries of the major surfaces A, C and E. The disk of copper film inside the ring on the surface C may be used as one element of a thermocouple. For example, a thermocouple junction 508 may be assembled by soldering, brazing, or welding one end of an insulated chromel wire to the copper film, preferably, but not necessarily, at or near the center of the surface C. The other end of the chromel wire is soldered, brazed, or welded to a chromel electrode mounted to the tab 505. Another thermocouple junction 510 may be similarly assembled on the major surface E. Copper is etched from the major surfaces B, D, and F so that those surfaces have no copper thereon.

With the heater and thermocouple junctions thus formed, the support assembly 500 may be Z-folded as shown in FIG. 3C. Preferably, the sections 502 and 504 are folded at 509 by swinging the major surfaces B and C together and the sections 504 and 506 are folded at 511 by swinging the major surfaces D and E together. The folded support assembly is seen in the top plan view of FIG. 3D. In this aspect, the support assembly 500 is preferably oriented with respect to a location on a body where a deep tissue temperature reading is to be taken by denominating the heater as the top of the assembly, and major surface F as the bottom. In this aspect, the tabs 503, 505, and 507 are aligned by the folding so as to position all of the leads and pins on a single side of a composite tab 520. Preferably, but not necessarily, the composite tab 520 is oriented with the aligned pins facing in the same direction as the heater on major surface A. Table I below sets forth the pin assignments. In the table, the lower thermocouple is on major surface E and the upper thermocouple is on major surface C. The connectors on the composite tab 520 provide electrical access to each of the thermal sensors and to the heater. A compression connector may be attached to the composite tab.

TABLE I

PIN	DESCRIPTION
1	COPPER-OUTER THERMOCOUPLE
2	CHROMEL-OUTER THERMOCOUPLE
3	COPPER-INNER THERMOCOUPLE
4	CHROMEL-INNER THERMOCOUPLE
5	HEATER
6	HEATER

With reference to the paddle-shaped support assembly 500 seen in FIG. 3D, the view is toward the top side; that is to say the view is toward the side that does not contact the skin region where temperature is being measured. On the top side, the heater 514 is centered on the center portion 526 of the support assembly 500. The zones of the heater form a pinwheel-like pattern whose individual blades extend from the center portion 526 toward the periphery 528 of the support assembly 500. The pinwheel configuration of the copper traces defines wedge-shaped heater zones 529 in the support assembly 500, each including a pinwheel blade trace and a slightly thicker wedge of support assembly structure underlying the trace. The slits 513 are aligned through the support assembly structure, extending entirely through the support assembly components, including the layers of substrate and

thermal resistance. The slits permit the zones to move independently with respect to each other, thereby investing the support assembly 500 with additional flexibility.

An alternate embodiment of a slitted, multi-zone support structure is shown in FIGS. 3E and 3F, where a multi-zone heater 534 is formed with partially circular or arcuate traces which increase in radius from an unheated center portion 536 to the periphery 538 of the support assembly 500. Thermocouple junctions 508 and 510 are formed as disclosed above. Partially circular or arcuate slits 542 are formed through the contiguous sections of the support assembly structure. When the sections are folded as per FIG. 3C the slits 542, are aligned so as to extend entirely through the support assembly components, including the layers of substrate and thermal resistance. The slits 542 are concentric with the disks and mutually aligned at their ends so as to define a non-slitted, generally wedge-shaped portion 544 of the support assembly 500. The slits are positioned between heater traces so as to define partially circular heater zones 546 in the support assembly 500, each including partially circular heater traces and a slightly thicker partial circle of support assembly structure underlying the traces. The slits 542 permit the partially circular heater zones to move independently with respect to each other, thereby investing the support structure with additional flexibility. Pin assignments on the tab are as per Table I.

Final assembly of a DTT probe construction with a support assembly according to the embodiments described above is illustrated in FIG. 4. In the unfolded assembly, there are three circular disks and six surface regions. Layers formed by folding the support assembly are labeled as shown in the figures. The layers are, as follows:

Major surface A is the electric heater

Major surface B is a plastic film

Major surface C is a copper layer that supports a thermal sensor

Major surface D is a plastic film

Major surface E is a copper layer that supports a thermal sensor

Major surface F is a plastic film

The assembled DTT probe may include additional layers added to the structure of the probe during assembly. For example, layers of pressure-sensitive adhesive (PSA) may be disposed between the folded sections and on the top and bottom major surfaces, an insulating layer may be disposed on the layer of PSA above the heater, and a further layer of PSA may be disposed on the top of the insulating layer. Further, a release liner may be provided on the bottom PSA layer, and an aluminum radiation shield may be supported on the top PSA layer.

As per FIG. 4, the support assembly embodiments of FIGS. 3D and 3F include thermal sensors TC (thermocouples, preferably) mounted on the center portions of the top side of the support assembly sections. As the thermal sensors are mounted substantially in the centers of folded-together disks, they are vertically aligned along a central axis passing through the centers.

The third support assembly embodiment illustrated in FIGS. 5A and 5B is characterized by a structure with a single substrate layer formed into a plurality of contiguous sections that are separated into strata on which thermal sensors are disposed in a spaced-apart relationship. Preferably, the thermal sensors are disposed on separate concentric support members in a radially separated relationship. Preferably, the substrate has a paddle-like shape with nested partially circular heaters disposed thereon. At least two sensor support sections are separated by a thermally insulating layer separate from the substrate. It is desirable to provide a lead support tab

projecting outwardly of the paddle's disk and supporting leads for the heaters and the thermal sensors.

With reference to FIGS. 5A and 5B, the plan view shows a flexible, two-sided substrate 602 formed into a paddle shape with a disk 620 and a tab 621. Concentric, partially circular heater traces 613 and 615 are formed on one side of the substrate 602. A notched area 625 extends into the inside edge of the outside heater trace 613. The thermal sensors 610 and 612 are disposed on the same side of the substrate 602 as the heater traces. The thermal sensor 612 is located substantially in a center portion 619 of the disk 620. The thermal sensor 610 is located in the notch 625 formed in the outermost heater trace 613. Traces for leads and pins extend along the tab 621. The substrate 602 is die-cut to form paddle-shaped slits 630 which extend through the substrate. A first slit has a partially circular section between the heater traces 613, 615 and spaced apart elongate sections along the tab 621. Another slit has a partially circular section between the innermost heater trace 615 and the center portion 619 and also includes spaced apart elongate sections along the tab 621.

As best seen in FIG. 5A, the paddle-shaped slits 630 define separable sections 604, 606, 608 of the support assembly that can be separated into strata. Preferably, the sections are separated so that the section 608 is disposed between the sections 604 and 606, and the sections 606 and 608 are disposed so that the heater 615 is positioned above the thermal sensor 612, while the heater 613 and thermal sensor 610 are positioned below the thermal sensor 612. At least one layer 617 of thermally insulating material that is separate from the substrate is interposed between the sections 604 and 606, which produces a vertical separation, and inserts a thermal resistance, between the thermal sensors 610 and 612. If necessary, a second layer 623 of thermally insulating material that is separate from the substrate 602 may also be interposed between the sections 608 and 606, which produces a vertical separation, and inserts a thermal resistance, between the thermal sensor 612 and the heater 615. A flexible layer of insulating material 640 is applied by pressure sensitive adhesive to the section 606, over the heater 613, and a layer of patient adhesive 642, with a removable backing is applied to the bottom of the section 604.

A support assembly according to any of the embodiments disclosed herein may be constructed using a substrate constituted of a single double-sided sheet of plastic film such as Kapton® polyimide, Kaptrex® polyimide, polyester or another film of flexible, thermally insulating material. The sheet may be coated on one or both sides with a copper film and various elements such as heaters, copper disks, and copper leads and pins may be made by photo-etching before the support assembly is folded or separated. The sheet may then be die-cut to the required shape and folded or separated as described above. Other metals with high thermal conductivities, like gold or aluminum, may also be used, although copper is preferred because it can form one half of a T-type thermocouple; however, other types of thermocouples are possible, and it may be possible to dispense with metal films altogether if other thermal sensors such as balanced RTD's, thermistors, and/or point junction thermocouples are used to measure temperature. Chromel traces and leads may be formed by deposition, or by peening.

A disposable DTT probe may be easily and inexpensively made using the support assembly construction embodiments described above. Disposability makes the commercialization of a DTT probe possible. Also, a single-use probe limits the potential for cross-contamination and makes it possible for more patients to benefit from perioperative temperature monitoring.

Although the invention has been described with reference to the presently preferred embodiment, it should be understood that various modifications can be made without departing from the spirit of the invention. Accordingly, the invention is limited only by the following claims.

The invention claimed is:

1. A support assembly for a deep tissue temperature probe, comprising:

a substrate with two sides;

a plurality of sections defined in the substrate, in which each section is joined to at least one adjacent section at a peripheral location common to both sections;

a first thermal sensor and a second thermal sensors, each supported on a respective one of two adjacent sections; and, a heater supported on the substrate; and,

a pattern of slits in one of the two adjacent sections, wherein each of the pattern of slits comprises an opening extending within and through the substrate, wherein the pattern of slits in the one of the two adjacent sections includes at least three slits.

2. The support assembly of claim 1, wherein the first thermal sensor is mounted on a surface of a first section of the two adjacent sections, the second thermal sensor is mounted on a surface of a second section of the two adjacent sections, each section of the two adjacent sections has a pattern of slits, the pattern of slits define a plurality of zones in the heater, and the sections are capable of being folded together such that the slits are aligned and open through all of the sections.

3. The support assembly of claim 2, wherein the zones are wedge shaped and the slits are radial slits.

4. The support assembly of claim 2, wherein the zones are arcuately shaped and the slits are arcuately-shaped slits.

5. The support assembly of claim 2, wherein the zones are partially circular and the slits are partially circular slits.

6. A support assembly for a deep tissue temperature probe, comprising:

a flexible substrate with at least two sections;

a plurality of zones defined in one of the sections;

two thermal sensors, each supported on a respective one of two adjacent sections, at least one of the sections having a pattern of slits, wherein the pattern of slits includes at least three slits, wherein each of the pattern of slits comprises an openings extending within and through the substrate; and,

a heater supported on the flexible substrate and including a heater zone positioned on each of the plurality of zones.

7. The support assembly of claim 6, wherein the plurality of zones are wedge shaped and form a pinwheel configuration in which each zone is flexible independently of the other one of the plurality of zones.

8. The support assembly of claim 6, wherein the zones are arcuately shaped and each zone is flexible independently of any other zone.

9. The support assembly of claim 6, wherein the zones are partially circularly shaped and each zone is flexible independently of any other zone.

\* \* \* \* \*

专利名称(译)	深层组织温度探针结构		
公开(公告)号	<a href="#">US9310257</a>	公开(公告)日	2016-04-12
申请号	US12/798945	申请日	2010-04-14
[标]申请(专利权)人(译)	阿里贊特保健公司		
申请(专利权)人(译)	ARIZANT HEALTHCARE INC.		
当前申请(专利权)人(译)	3M创新有限公司		
[标]发明人	BIEBERICH MARK T VAN DUREN ALBERT P		
发明人	BIEBERICH, MARK T. VAN DUREN, ALBERT P.		
IPC分类号	A61B5/00 G01K1/16 A61B5/01 G01K13/00		
CPC分类号	A61B5/01 A61B5/6833 A61B5/6843 G01K1/16 G01K1/165 G01K13/002 A61B2562/0271 A61B2562/0276 A61B2562/164		
优先权	61/212749 2009-04-15 US		
其他公开文献	US20100268113A1		
外部链接	<a href="#">Espacenet</a> <a href="#">USPTO</a>		

摘要(译)

使用由支撑探针元件的柔性基底构成的支撑组件构造一次性零热通量深层组织温度探针。一个支撑组件实施例包括具有加热器的折叠基板 and 设置在其上的热传感器。另一个支撑组件包括可分离成支撑覆盖保护加热器的层的多个部分，中央热传感器和至少从中心热传感器径向移位的热传感器。

