



US007314752B2

(12) **United States Patent**
Kritzman et al.

(10) **Patent No.:** **US 7,314,752 B2**
(45) **Date of Patent:** **Jan. 1, 2008**

(54) **SECRETION-MONITORING ARTICLE**
(75) Inventors: **Amnon Kritzman**, Zichron Yaakov
(IL); **Nitsa G. Nachshon**, Kibbutz Geva
(IL); **Yael Behar**, Moshav Ein Ayala
(IL)

(73) Assignee: **Common Sense, Ltd.**, Caesarea (IL)

(*) Notice: Subject to any disclaimer, the term of this patent is extended or adjusted under 35 U.S.C. 154(b) by 268 days.

(21) Appl. No.: **11/105,438**

(22) Filed: **Apr. 14, 2005**
(Under 37 CFR 1.47)

(65) **Prior Publication Data**

US 2007/0003993 A1 Jan. 4, 2007

Related U.S. Application Data

(63) Continuation-in-part of application No. 10/285,499, filed on Nov. 1, 2002, now Pat. No. 6,921,647, which is a continuation-in-part of application No. PCT/IL02/00588, filed on Jul. 18, 2002, which is a continuation-in-part of application No. 09/907,926, filed on Jul. 19, 2001, now Pat. No. 6,627,394.

(60) Provisional application No. 60/365,684, filed on Mar. 18, 2002.

(51) **Int. Cl.**
C12M 1/34 (2006.01)

(52) **U.S. Cl.** **435/288.7**; 422/56; 604/358

(58) **Field of Classification Search** 435/288.7;
422/56-60; 436/163, 169; 604/318, 358
See application file for complete search history.

(56) **References Cited**

U.S. PATENT DOCUMENTS

2,664,879 A	1/1954	Hardy	128/2
3,427,225 A	2/1969	Harvill	195/103.5
3,509,872 A	5/1970	Truhan	128/2
4,029,597 A	6/1977	Neisius et al.	252/408
4,029,598 A	6/1977	Neisius et al.	252/408
4,532,216 A	7/1985	Wang	436/2
4,666,833 A	5/1987	Roy et al.	435/26
5,063,930 A	11/1991	Nucci	128/632
5,094,955 A	3/1992	Calandra et al.	435/291
5,217,444 A	6/1993	Schoenfeld	604/361
5,275,591 A	1/1994	Mavinkurve	604/387
5,312,591 A	5/1994	Doi	422/56

5,384,411 A	1/1995	Robotti et al.	549/31
5,425,377 A	6/1995	Caillouette	128/759
5,445,147 A	8/1995	Schoendorfer et al.	128/632
5,468,236 A	11/1995	Everhart et al.	604/361
5,660,790 A	8/1997	Lawrence et al.	422/56
5,823,953 A	10/1998	Roskin et al.	600/367
5,823,954 A	10/1998	Chaffringeon	600/367
5,853,669 A	12/1998	Wolfbeis	424/82.05
5,876,389 A	3/1999	Bouchard et al.	604/385.1
5,897,834 A	4/1999	Lawrence et al.	422/56
5,910,447 A	6/1999	Lawrence et al.	436/111
6,099,801 A	8/2000	Lawrence et al.	422/56
6,106,461 A	8/2000	Roskin et al.	600/309
6,126,597 A	10/2000	Smith et al.	600/362
6,149,590 A	11/2000	Smith et al.	600/367
6,200,817 B1	3/2001	Lawrence	436/111
6,203,496 B1	3/2001	Gael et al.	600/362
6,395,955 B1	5/2002	Roe et al.	604/361
6,426,227 B1*	7/2002	Kritzman et al.	436/43
6,610,904 B1	8/2003	Thomas et al.	604/383
6,627,394 B2*	9/2003	Kritzman et al.	435/4
6,627,790 B2	9/2003	Bouchard et al.	604/383
6,689,114 B2	2/2004	Bouchard et al.	604/385.14
6,921,647 B2*	7/2005	Kritzman et al.	435/12
2001/0025140 A1	9/2001	Torok et al.	600/367
2003/0120180 A1*	6/2003	Kaylor et al.	600/584
2003/0166293 A1	9/2003	Kritzman et al.	436/111
2007/0073192 A1*	3/2007	Caillouette	600/584

FOREIGN PATENT DOCUMENTS

DE	199 14 037 A1	9/2000
DE	100 16 383 A1	6/2001

* cited by examiner

Primary Examiner—Ralph Gitomer
(74) *Attorney, Agent, or Firm*—Winston & Strawn LLP

(57) **ABSTRACT**

A secretion-monitoring article for identifying a secreted biological fluid. The article includes a body with an absorbent material for absorbing a biological fluid secreted from a person and an indicator system. The indicator system includes an indicator agent and an ion-balance reagent, wherein the indicator system provides an indication of physiological conditions associated with the pH or the buffer capacities of the biological fluid, which indication is stable for at least 48 and preferably at least 72 hours. The article can be embodied as a swab, gauze, shield, hygienic napkin, diaper or interlabial absorbent structure and can be used to indicate the presence of amniotic fluid, or secretions associated with bacterial vaginosis without giving a false positive result upon exposure to urine or after drying.

22 Claims, 8 Drawing Sheets

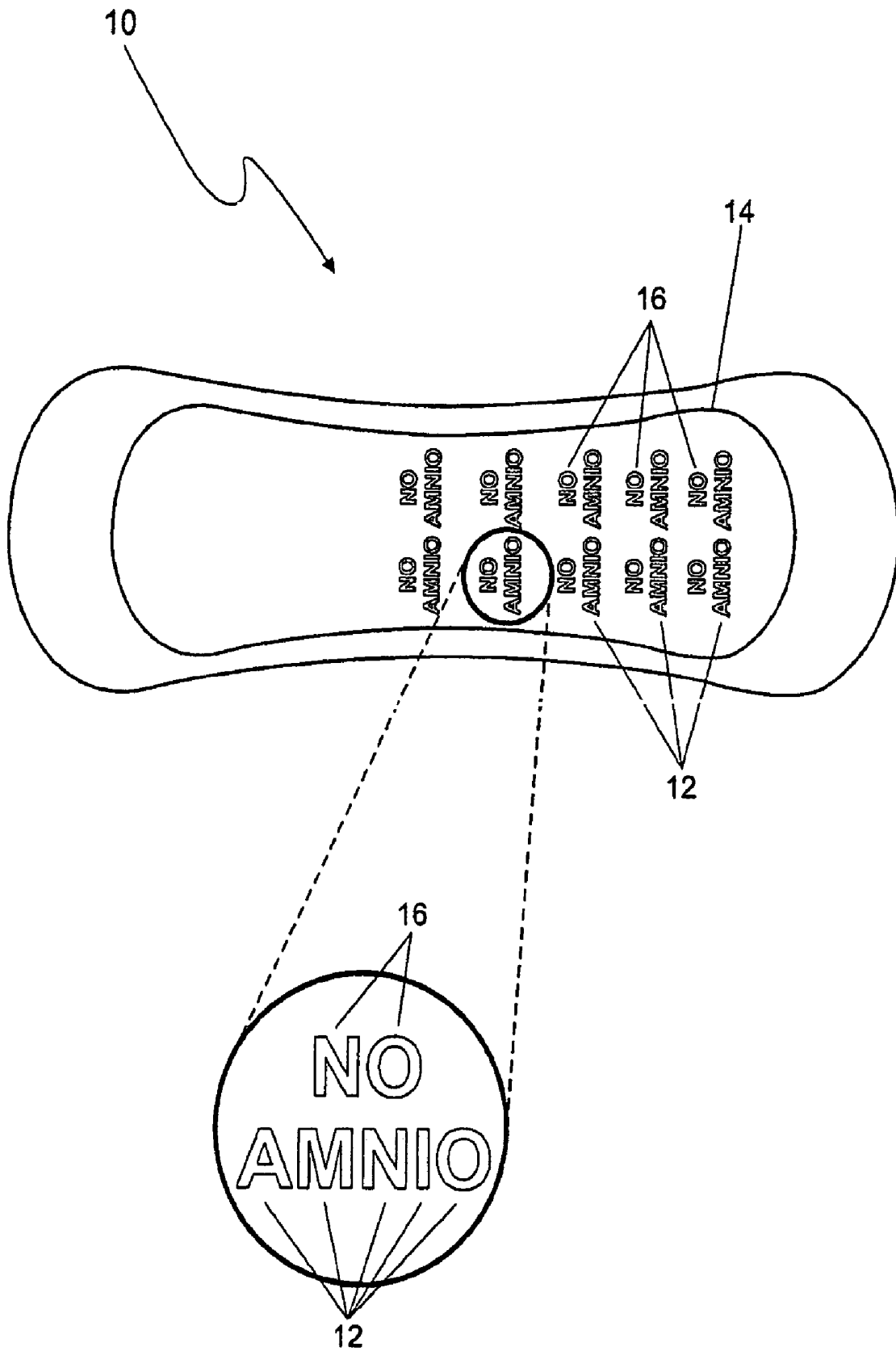

Fig. 1A

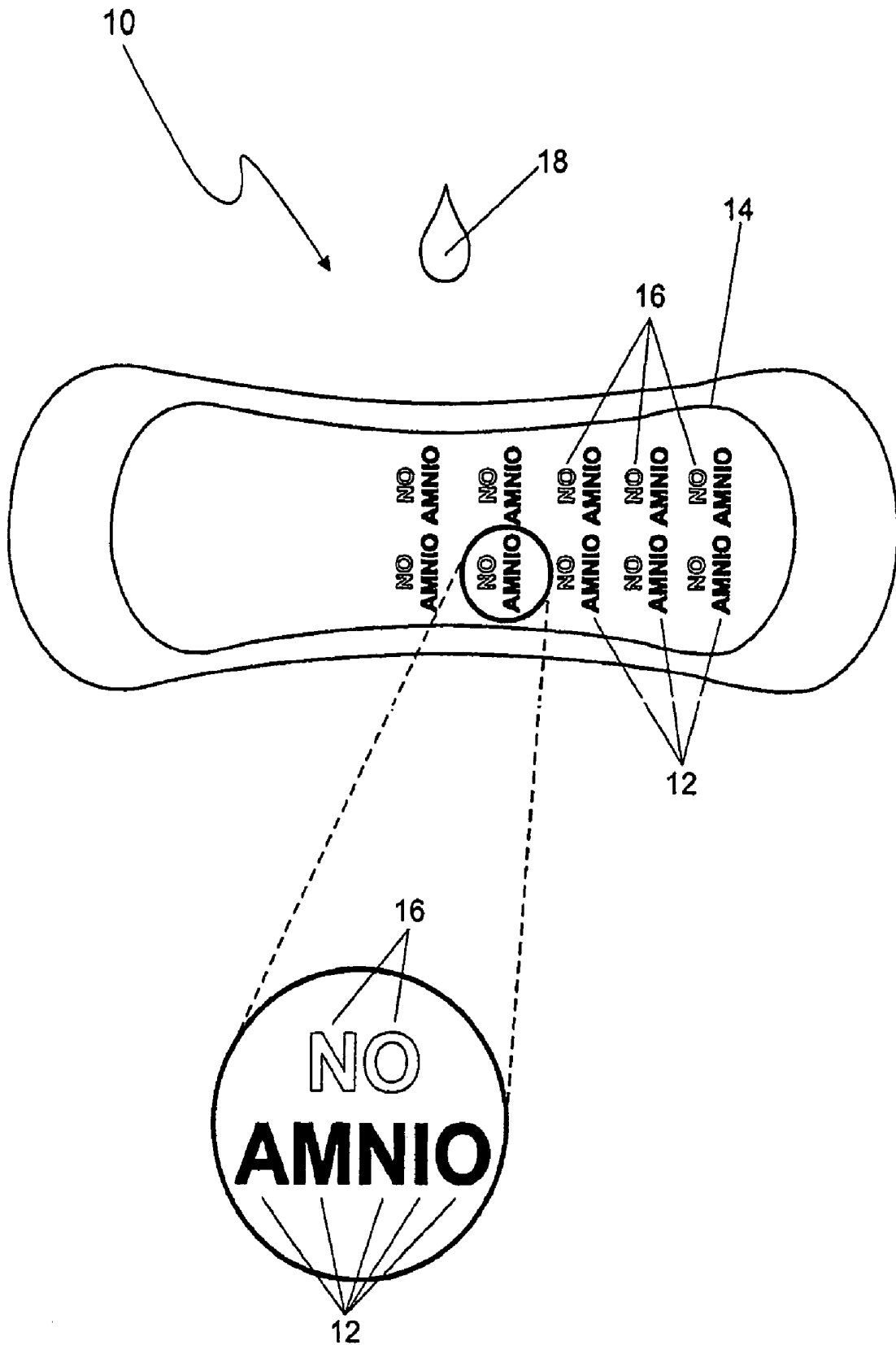

Fig. 1B

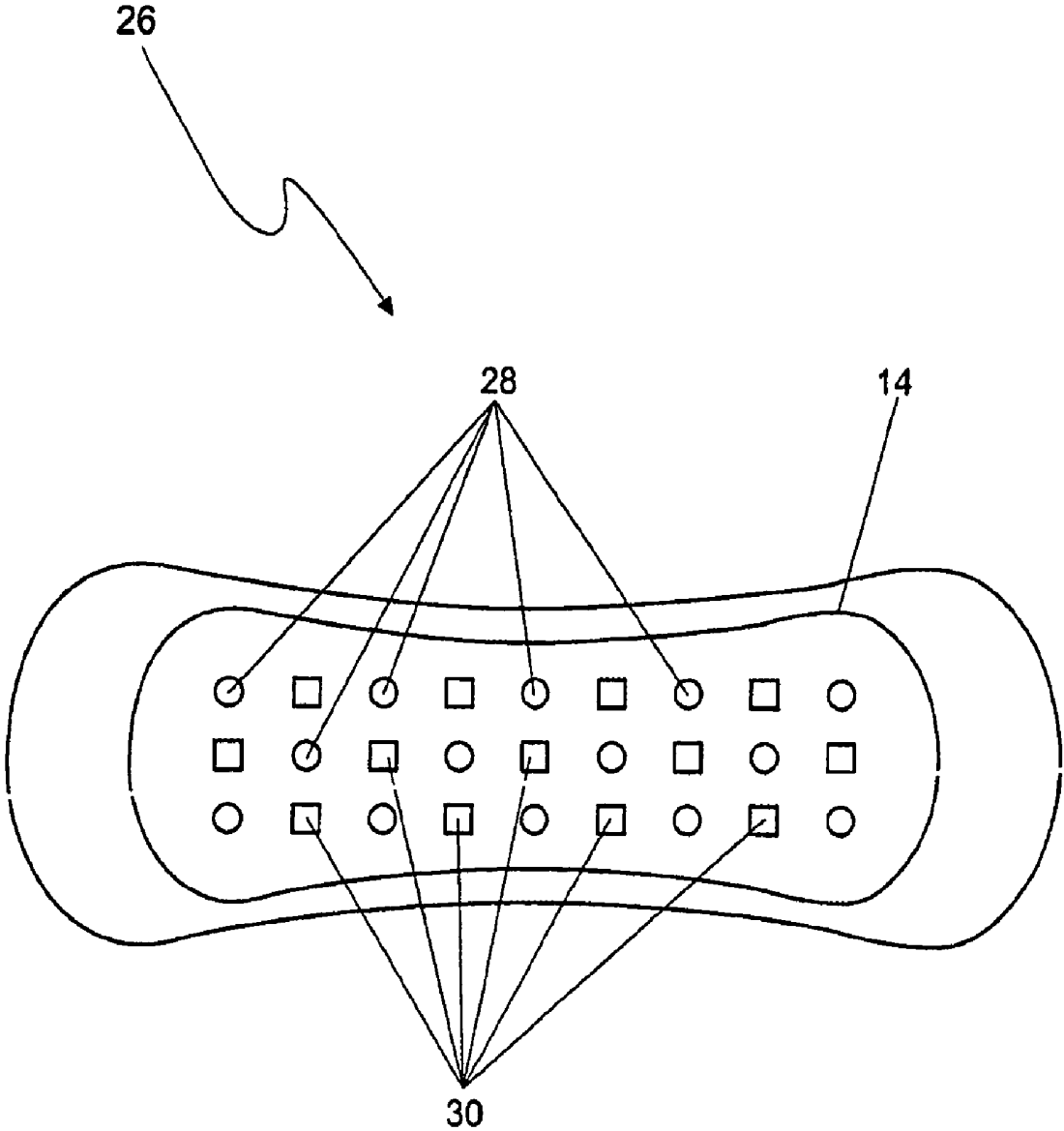

Fig. 2

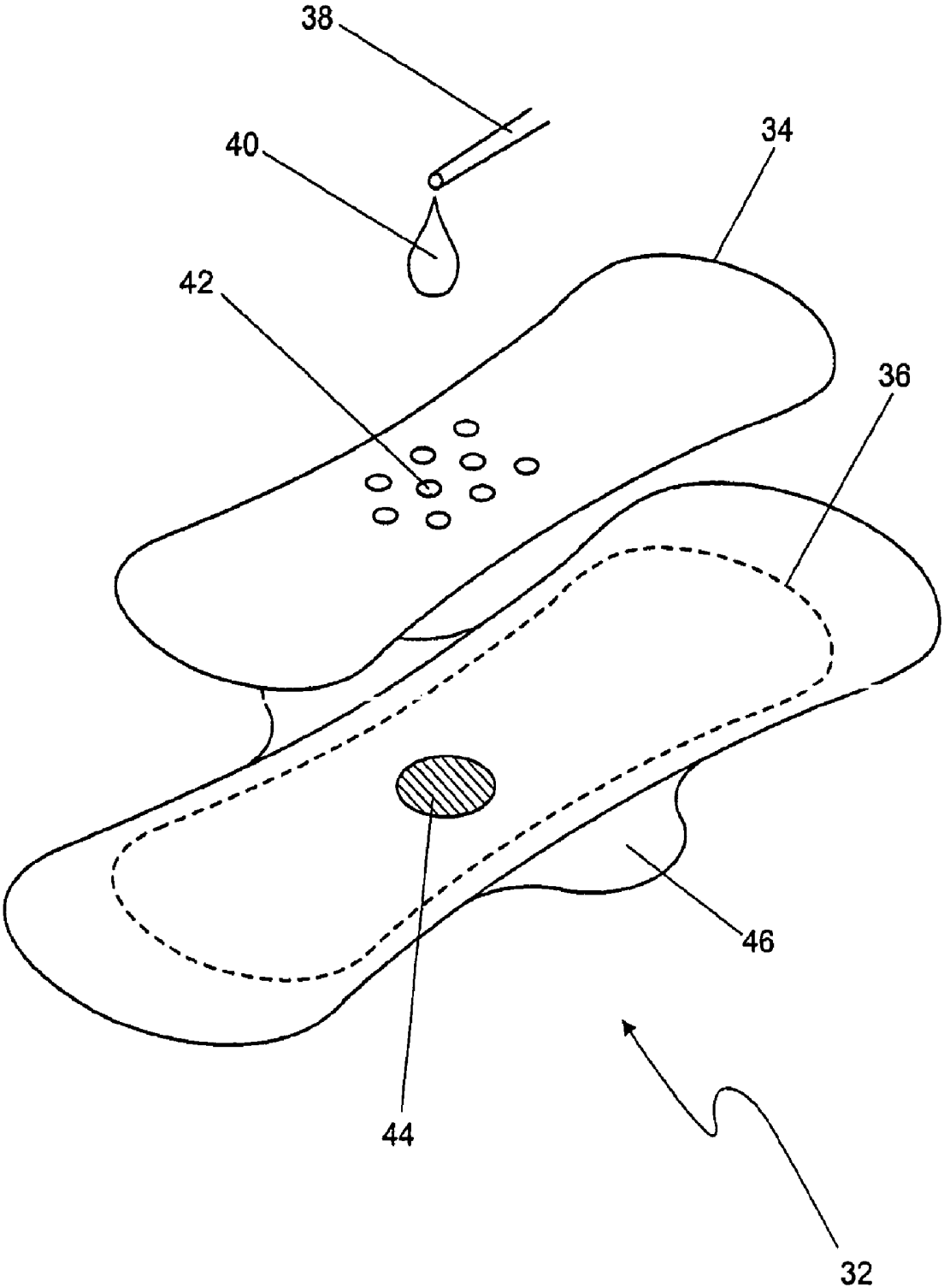

Fig. 3

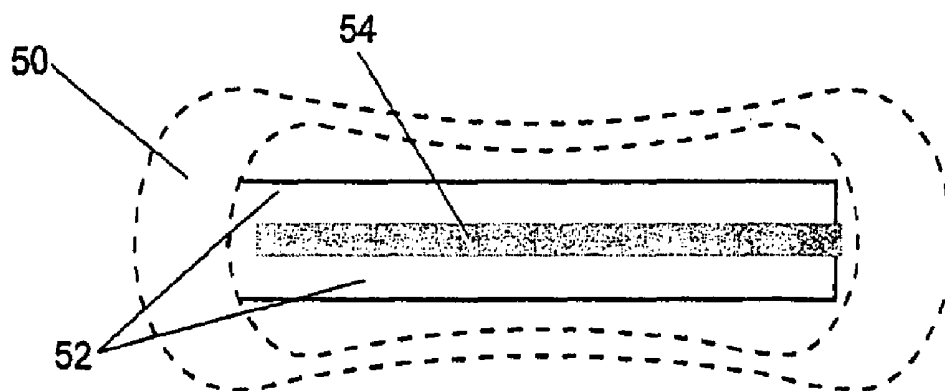

Fig. 4A

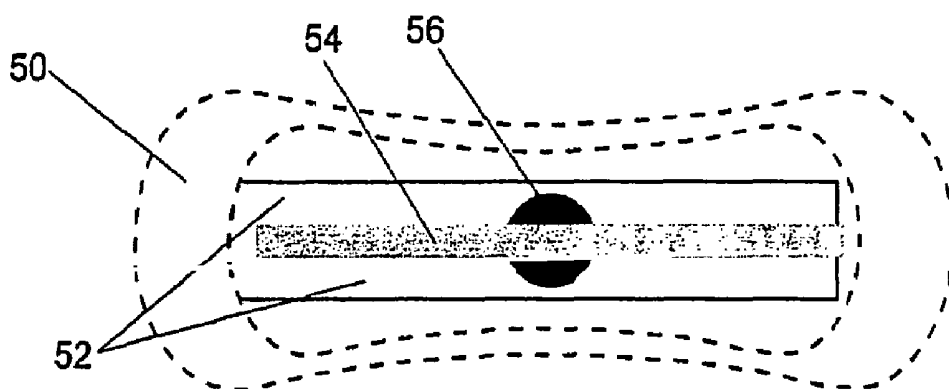

Fig. 4B

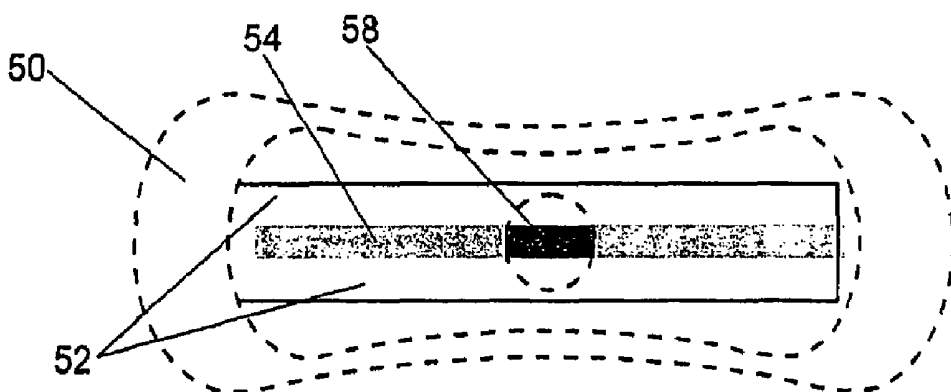

Fig. 4C

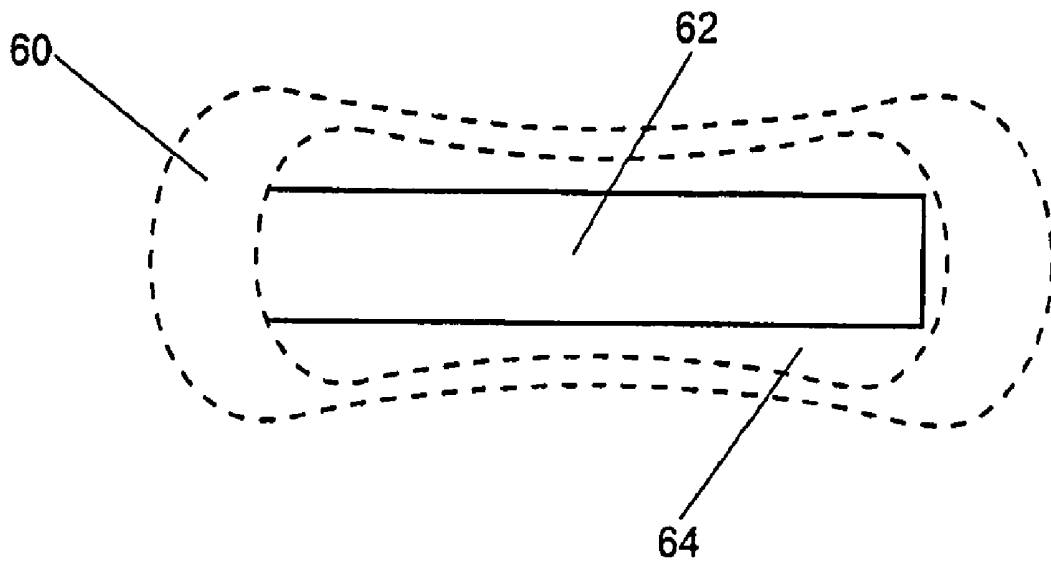

Fig. 5A

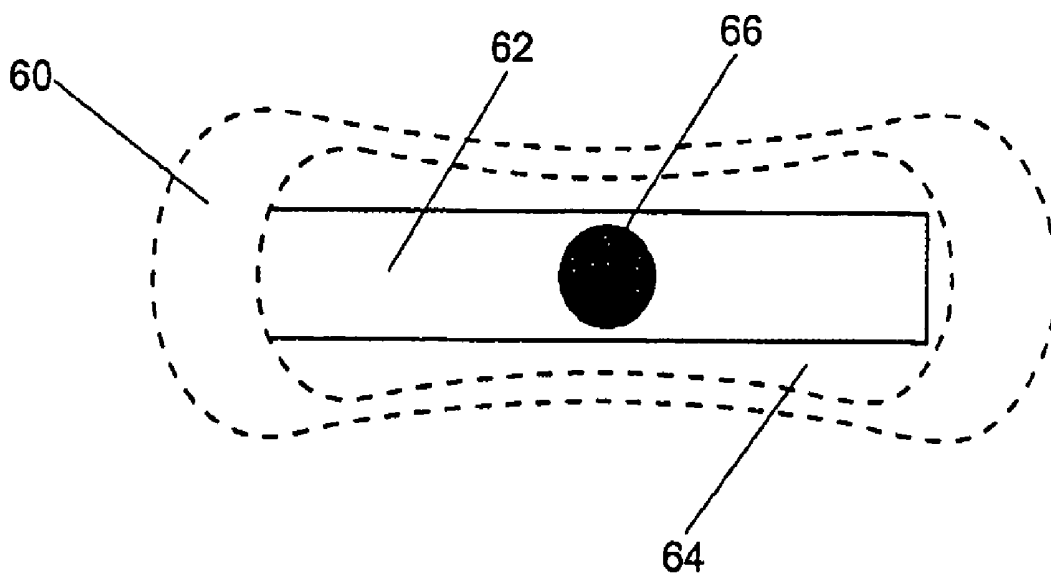

Fig. 5B

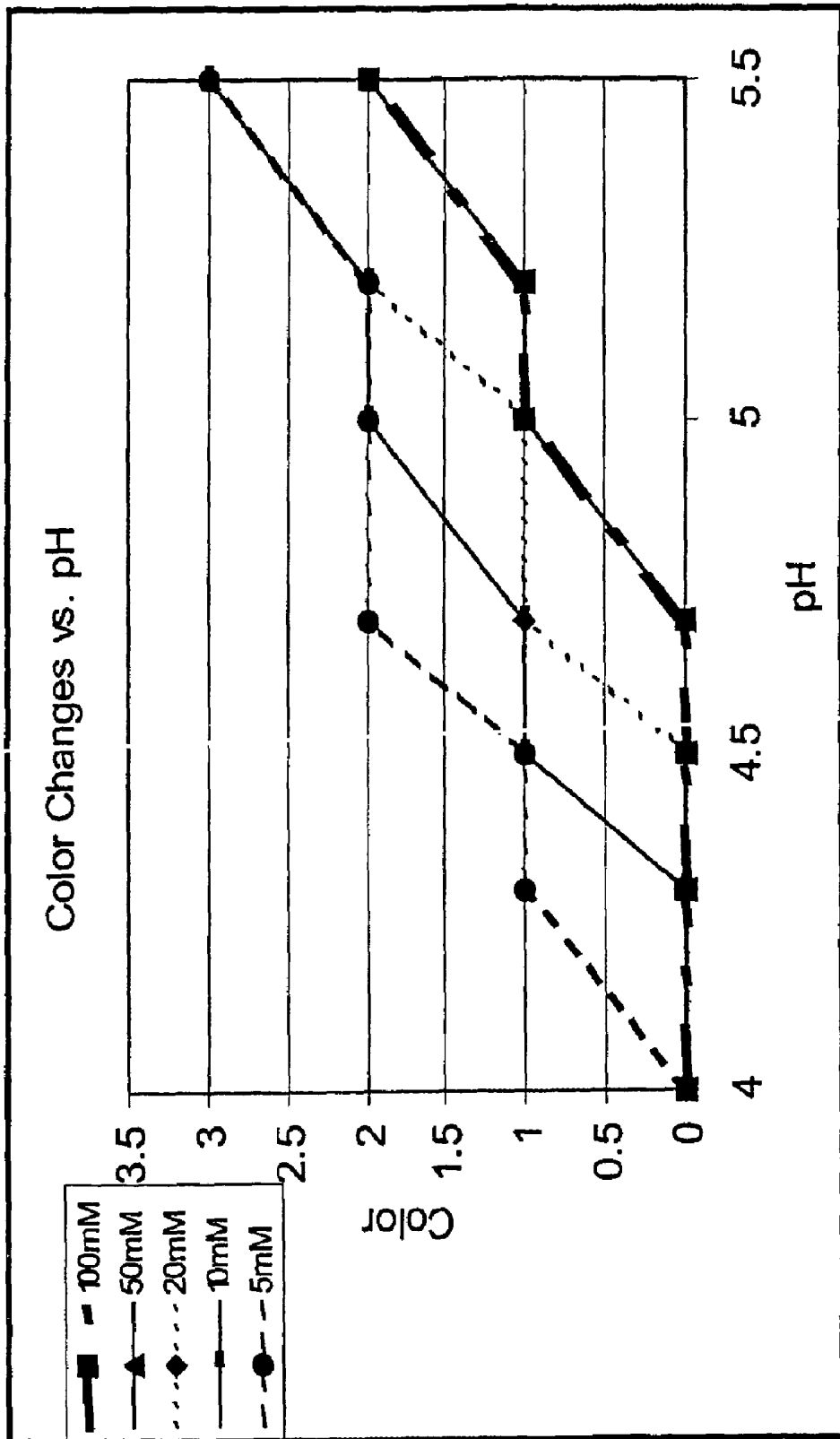

Fig. 6

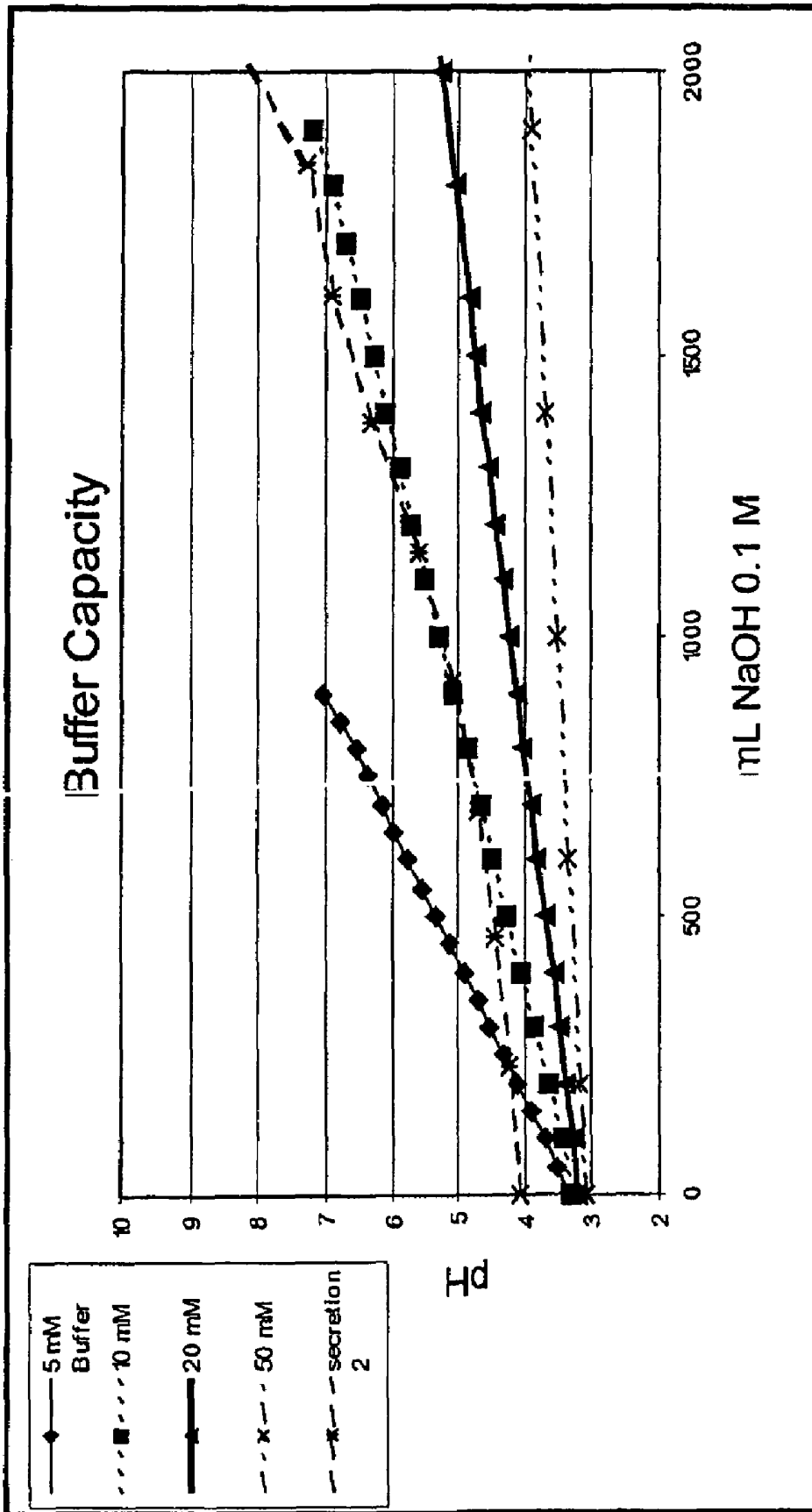

Fig. 7

SECRETION-MONITORING ARTICLE

CROSS-REFERENCE TO RELATED APPLICATIONS

This application is a continuation-in-part of U.S. application Ser. No. 10/285,499 (issued as U.S. Pat. No. 6,921,647), filed Nov. 1, 2002, which in turn is a continuation-in-part of International Application PCT/IL 02/00588, filed Jul. 18, 2002, which claims the benefit of U.S. Provisional Application Ser. No. 60/365,684, filed Mar. 18, 2002 and is a continuation-in-part of U.S. application Ser. No. 09/907,926 (issued as U.S. Pat. No. 6,627,394), filed Jul. 19, 2001.

TECHNICAL FIELD

The present invention relates to the field of medical diagnostics and more specifically, to an improved identification of secreted biological fluids using a secretion-monitoring article to identify amniotic fluid or secretions associated with bacterial, parasite, fungal, or yeast infections even in the presence of interfering biological fluids. The present invention also relates to improved methods of attaching an indicator to a substrate and methods of preparing and using a secretion monitoring article to identify a secretion.

BACKGROUND OF THE INVENTION

Many bodily fluids can be readily identified by chemical properties such as pH. One exceptionally useful method of determining the pH of a liquid sample is through the use of an indicator, a chemical compound or combination of compounds, that has a pH dependent color. Well known examples include tea and wine. General details and descriptions of some indicators can be found, for example, in "Indicators," E. Bishop, Pergamon Press, 1972, chapter 3.

Often an indicator is attached to a solid substrate such as paper. A sample of a liquid of which the pH needs to be determined is applied to the substrate. The pH of the liquid is determined by the color of the indicator present on the substrate. Depending on how the indicator is attached to the substrate, application of the liquid sample may cause the indicator to leach out of the substrate. Indicator leaching is undesirable and so the indicator is often substantially immobilized on the substrate.

Various medical conditions can be diagnosed by identifying the chemical and physical properties of a vaginal secretion, such as, salts of volatile amines as disclosed in U.S. Pat. No. 6,099,801. Identifying the pH of the secretions also indicates the presence of medical conditions. U.S. Pat. Nos. 5,660,790 and 5,910,447 disclose test devices for analyzing the pH of an aqueous liquid sample, however, the pH range identified by these devices is extremely narrow, namely 4.6-4.8. Moreover, the pH indicator composition is hydrophilic and thus cannot readily retain a stable indication, particularly indications requiring dehydrated environment. U.S. Pat. No. 5,468,236 discloses a disposable absorbent product comprising a chemically reactive means adapted to provide a visual indication as a result of interacting with biological fluids. The properties of the chemical means however are not defined. Moreover, the visual indication is not adapted to provide a distinct indication for a desired substance in the presence of interfering fluids.

A number of devices involving panty shields with pH indicators are known in the art, for example in U.S. Pat. Nos. 5,217,444; 5,823,953; 6,106,461 and 6,689,114. These

devices can be worn by the user and whenever there is a secretion it is immediately detected by the pH indicator. U.S. Pat. No. 6,562,297 discloses an indicator bound to a hydrophilic synthetic membrane substrate and a device, such as a panty shield with an indicator bound to hydrophilic synthetic membrane substrate. A general problem, however, with these pH indicators is that they often provide "false positives" due to changes in pH on drying, interfering biological fluids and repetitive cycles of drying/wetting. Often a vaginal secretion cannot be identified with absolute certainty by an indicator due to the existence of a plurality of fluids collected with a similar pH. The "false positive" readings can be stressful and time consuming to the user. A device that minimizes these "false positive" readings is needed.

False positive readings can be caused, for example, by interfering biological fluids, such as urine. Vaginal secretions of a patient with vaginosis have a pH between 4.7 and 6.5. Because urine of a healthy patient has a pH between 5.0 and 8.0, it is very difficult to diagnose a secretion as arising from vaginosis with a high degree of confidence by just using a pH based indicator test. One solution known in the art is to sample fluid from within the vagina, where urine is not ordinarily found. This is uncomfortable and requires a visit to a health-care professional.

A second example is the identification of amniotic fluid leaking from the vagina of a pregnant woman. During pregnancy amniotic sac integrity may be compromised and a small amount of amniotic fluid may leak out through the cervix and from the vagina. If diagnosed as such, measures such as patient rest or sealing of the amniotic sack using biological glue may be prescribed. If not diagnosed the amniotic sack may later rupture causing abortion of the pregnancy, or require hospitalization of the woman and infant. If the infant is born prematurely, death or severe handicap may be a result. Extended hospitalization of the infant in an incubator is often necessary.

Due to the severe consequences of amniotic fluid leakage, pregnant women undergo severe stress and often go to a health-care professional upon secretion of any liquid from the vicinity of the vagina. The health-care professional looks for the presence of amniotic fluid by checking the pH of the vaginal secretions, amniotic fluid having a pH of between 6.0 and 8.0. Since pregnant women often have urinary incontinence and since urine typically has a pH of between 5.0 and 8.0, if only pH is checked, a false positive result may occur: urine being identified as amniotic fluid. Consequently, it is necessary that such a vaginal secretion be examined using a microscope for the presence of a fern-shaped pattern indicative of amniotic fluid.

As the time between the fluid secretion and the arrival at the health-care professional may be long, there is often no evidence of amniotic fluid upon examination. The secretion may mistakenly be assumed to be urine, often with tragic consequences. On the other hand, the healthcare professional may decide to err on the side of caution, misdiagnosing the secretion of urine as amniotic fluid leading to an unnecessary hospitalization and patient stress.

U.S. Pat. No. 6,126,597 (the '597 patent) and U.S. Pat. No. 6,149,590, (the '590 patent) a continuation-in-part of the '597 patent, are directed to a device in the form of a sanitary napkin with a pH indicator configured to identify the presence of amniotic fluid in a vaginal secretion. The '597 and '590 patents are subject to the problem of giving false positive results. The device of the '590 patent addresses this problem by further including in the device a microscope visualizable slide configured to gather a portion of a vaginal secretion. If the indicator shows the pH corresponding to

that of amniotic fluid, the user presents a health-care professional with the slide. The health-care professional examines the slide with the help of a microscope for the typical fern-shaped patterns indicative of the presence of amniotic fluid.

There are a couple of disadvantages associated with this device. First, it requires that the patient visits the health-care professional to distinguish between positive and false-positives and second, a significant amount of time is lost in having the slide viewed by a professional to determine if amniotic fluid is actually leaking.

U.S. Pat. No. 5,897,834 discloses a device useful in a clinical setting for the differentiation between urine and vaginal secretions associated with vaginosis or urine and amniotic fluid. The device includes the use of indicators with a negatively charged group immobilized to a solid polymer substrate containing quaternary ammonium groups. Further the device includes a gaseous amine-releasing reagent and an amine indicator. The use of the polymer substrate containing quaternary ammonium groups is disclosed to have an advantage of sharpening the pH dependent color transition. However, these polymer substrates have been found to be less useful in non-clinical settings: the indicated pH of dried vaginal secretions is low enough to be misdiagnosed as indicating vaginosis. Thus although the device disclosed in U.S. Pat. No. 5,897,834 is useful in a clinical setting where the health care professional applies the vaginal secretion to the device and observes the color change, if integrated in a patient useable device, such as a panty shield, the device gives abundant false positive results.

There is a need for an indicator system that can differentiate between a specific biological fluid of interest and an interfering biological fluid, such as, urine. Further there is a need for a device that can distinguish between normal vaginal secretions and those associated with amniotic fluid leakage or vaginosis. Further, a system in which false positive results are minimized and a reliable indication is stable over time, while reducing the amount of time required to get the reliable result is also needed. Such a system is ideally useable by the patient to lead to greater peace of mind and to minimize unnecessary hospital visits. The characteristics of such an indicator system must not change due to long use or as a result of a wetting drying cycle and must distinguish between interfering biological fluids and minimize false positive readings. The present invention now overcomes these problems and satisfies these needs.

SUMMARY OF THE INVENTION

The present invention overcomes the disadvantages of the prior art by the use of an indicator system integrated into various self useable products. Generally, the invention provides a secretion-monitoring article comprising an absorbent material for absorbing a biological fluid secreted from a person and an indicator system that has a hydrophobic chemical composition comprising an indicator agent and an ion-balance reagent. The indicator system is associated with the absorbent material such that the biological fluids absorbed by the absorbent material further contact the indicator system so that a reliable indication of the pH and/or buffer capacity of that fluid can be obtained, wherein a positive indication remains detectable for at least 48 hours, and preferably at least 72 hours.

The article can be presented to the user in many forms. It is preferable, however, that the article is in the form of a swab, gauze, panty shield, hygienic napkin, a diaper or interlabial absorbent structure. Furthermore, any user, male

or female, young or old, can use the article. The particular examples of the invention as presented herein are not intended to limit the scope of the invention, but simply to illustrate and represent the numerous potential forms in which the invention can be used.

Unexpectedly, indications corresponding to pathological conditions, such as, bacterial vaginosis and amniotic fluids, are stable and remain indicative for at least 48 hours.

Advantageously, the indicator system has a chemical composition that reacts with biological fluids containing protonated amine cations differently than with bodily fluids that do not contain protonated amine cations.

Preferably, the article has a mounting means for positioning the absorbent body to receive the fluids secreted during the normal activity of the user, such mounting means being, for example, an adhesive strip or other attachment member.

Typically, the indicator system is associated with the absorbent material such that the biological fluids contact the indicator system while being worn.

Further, the invention provides a method of attaching an indicator to a substrate. The substrate can be made of many materials, for example, polypropylene, paper or cotton, polyester membranes and can be of many structures including of a membrane, fabric, mesh, gauze, thread, fiber and a sheet. A mixture comprising a pre-formed polymer (such as a cellulose), a plasticizer, a wetting agent, an ion-balance reagent and an indicator is prepared. In some embodiments, a solvent is added to the mixture. The mixture is applied to a substrate for example by dipping the substrate in the mixture or by spraying or spreading the mixture onto the substrate. The substrate with the applied mixture is allowed to dry. When dry, the indicator is bound to the substrate with the help of the polymer. This method is exceptionally useful when the indicators have a substantially negatively charged functional group such as an acetate or a sulfonate.

There is also provided according to the teachings of the present invention an additional method of making a diagnostic article comprising of the steps of attaching an indicator to a substrate, especially a neutral substrate, by applying a surfactant solution to the substrate and letting it dry, preferably under vacuum, then once the surfactant is dry, an indicator solution or a solution with a reagent is applied to the substrate and allowed to dry, preferably under vacuum, wherein the indicator to be attached to the substrate preferably is a substantially negatively charged functional group with a cationic surfactant. The method further comprises placing the indicator in association with an absorbent body.

According to one aspect, the present invention provides a secretion-monitoring article comprising a body that includes an absorbent material for absorbing a biological fluid secreted from a person and an indicator system having a hydrophobic chemical composition comprising an indicator agent and an ion-balance reagent, wherein the indicator system provides an indication of physiological conditions associated with the pH or the buffer capacities of the biological fluid, which indication is stable for at least 48 hours.

According to one embodiment, the molar ratio of the ion-balance reagent to the indicator agent is within the range of 5:1 to 15:1.

According to another embodiment, the pKa of the indicator agent is lower than the pH of the biological fluid, said pH is determined by a physiological condition. According to yet another embodiment, the indicator agent is negatively charged. According to yet another embodiment the indicator agent is a weak acid. According to yet another embodiment, the indicator agent is nitrazine yellow.

According to yet another embodiment, the ion-balance reagent is a quaternary amine. According to another embodiment, the ion-balance reagent is selected from the group consisting of: di(long-chain alkyl)dimethyl ammonium chloride, N-methyl-N,N-bis(long-chain alkanoyl oxyethyl)-N-(2-hydroxyethyl)ammonium methylsulfate, vinylbenzyl dimethylcocoammonium chloride, and methyl trioctyl ammonium chloride. According to a preferred embodiment, the quaternary ammonium salt is selected from the group consisting of: tricapyrylmethyl ammonium chloride, tri-dodecylmethyl ammonium chloride and cetyltrimethyl ammonium chloride.

According to yet another embodiment, the stable indication is detectable for at least 72 hours. According to yet another embodiment, secretion-monitoring article comprises a plurality of indicator systems.

In a preferred embodiment, the secretion-monitoring article further comprises mounting means for placing the absorbent body in a position to receive the biological fluid secreted from the person.

In a non-limiting embodiment, the absorbent material is selected from the group consisting of: swab, gauze, panty shield, hygienic napkin, a diaper and interlabial absorbent structure.

According to certain embodiments, the biological fluid is a vaginal secretion, amniotic fluid or urine. According to yet other embodiments, the indicator system irreversibly changes color for at least 48 hours when contacted by a vaginal secretion associated with vaginosis or amniotic fluid leakage, but preferably reversibly changes color when contacted by urine.

Preferably the indicator mixture comprises: a pre-formed polymer in an amount of about 20% to 50%; a plasticizer polymer in an amount of about 15% to 40%; a wetting agent polymer in an amount of about 15% to 45%; an ion-balance reagent polymer in an amount of about 0.1% to 10%; and an indicator agent in an amount of about 0.05% to 5%; wherein the percents are weight percent based on the total weight of the mixture and the total weight of the mixture equals 100%.

According to some embodiments, the pH indicator mixture comprises: a pre-formed polymer in an amount of about 36% to 39%; a plasticizer polymer in an amount of about 27% to 29%; a wetting agent polymer in an amount of about 29% to 31%; an ion-balance reagent polymer in an amount of about 4% to 6%; and an indicator agent in an amount of about 0.2% to 0.4%.

According to a preferred embodiment, the molar ratio of ion-balance reagent to indicator agent is within the range of 5:1 to 15:1.

Advantageously, the pre-formed polymer can be a weakly acidic polyelectrolyte polymer. According to yet another embodiment, the polymer is cellulose or cellulose derivative. According to a preferred embodiment, the polymer is selected from the group consisting of: cellulose, sodium carboxymethyl cellulose, ethyl cellulose, nitrocellulose and cellulose acetate.

The wetting agent preferably is selected from the group consisting of: triethylene glycol, ethylene glycol, sorbitol and 2-ethoxy ethanol and the plasticizer is selected from the group consisting of: castor oil, diacetylated monoglycerides, diethyl phthalate, glycerin, mono- and di-acetylated monoglycerides, polyethylene glycol, propylene glycol, triacetin, triethyl citrate, bis-(2-butoxyethyl)adipate, bis-(2-ethylhexyl)sebacate and dibutylphthalate. According to a preferred embodiment, the plasticizer is selected from the group consisting of: diethyl phthalate, dibutylphthalate, bis-(2-butoxyethyl)adipate and bis-(2-ethylhexyl)sebacate.

Preferably the ion-balance reagent polymer is a quaternary ammonium salt. More preferably the ion-balance reagent is selected from the group consisting of: di(long-chain alkyl)dimethyl ammonium chloride, N-methyl-N,N-bis(long-chain alkanoyl oxyethyl)-N-(2-hydroxyethyl)ammonium methylsulfate, vinylbenzyl dimethylcocoammonium chloride, and methyl trioctyl ammonium chloride. According to a preferred embodiment, the quaternary ammonium salt is selected from the group consisting of: tricapyrylmethyl ammonium chloride, tri-dodecylmethyl ammonium chloride and cetyltrimethyl ammonium chloride.

According to yet another embodiment, the indicator is negatively charged. Preferably the indicator agent is a negatively charged functional group selected from acetate and sulfonate. In a preferred embodiment, the indicator agent is selected from the group consisting of: cresol red, alizarin, bromocresol purple, chlorophenol red, nitrazine yellow, bromthymol blue, bromoxyleneol blue, neutral red, phenol red, thymol blue, xylenol blue and m-cresol purple. According to a preferred embodiment, the indicator agent is nitrazine yellow.

According to another preferred embodiment, the indicator mixture comprises: a pre-formed cellulose acetate in an amount of about 20% to 30%; dibutylphthalate in an amount of about 10% to 20%; ethoxy ethanol polymer in an amount of about 20% to 30%; a quaternary ammonium salt in an amount of about 1% to 10%; and nitrazine yellow in an amount of about 0.05% to 5%; wherein the percents are weight percent based on the total weight of the mixture and the total weight of the mixture equals 100%.

According to yet another aspect, the present invention provides a method of attaching an indicator to a substrate, the method comprising: (a) providing a indicator mixture comprising pre-formed polymer, plasticizer, wetting agent, ion-balance reagent and an indicator; (b) applying the mixture onto a substrate; and (c) allowing said indicator mixture to attach to the substrate and to dry.

According to one embodiment, the mixture further comprises a solvent. According to another embodiment, the volume ratio between said mixture and the solvent is about 150:1 to about 150:30. According to yet another embodiment, the solvent is selected from the group consisting of: acetone, alcohol, diluted alcohol, amylene hydrate, benzyl benzoate, butyl alcohol, carbon tetrachloride, chloroform, corn oil, cottonseed oil, ethyl acetate, glycerin, hexylene glycol, isopropyl alcohol, methyl alcohol, methylene chloride, methyl isobutyl ketone, mineral oil, peanut oil, polyethylene glycol, propylene carbonate, propylene glycol, volatile ethers, tetrahydrofuran, sesame oil and water. According to a preferred embodiment the solvent is selected from the group consisting of: acetone, tetrahydrofuran and volatile ethers.

According to yet another embodiment, the substrate is selected from the group consisting of: polyester membranes, polypropylene membranes, cellulose membranes, paper, cotton and linen.

According to one embodiment the substrate is treated prior to application of the pH indicator mixture, the treatment includes applying a surfactant solution over said substrate following evaporation of the surfactant solution from said substrate. According to some embodiments, evaporation is conducted under pressure; preferably the pressure is less than 600 mmHg. According to other embodiment, the indicator mixture is negatively charged. According to certain embodiments the surfactant is positively charged.

According to another embodiment, said pH indicator mixture is applied to said substrate by a method selected from the group consisting of: dipping said substrate in said mixture, spraying said mixture on said substrate and spreading said mixture over said substrate.

According to yet another embodiment, the method further comprises integrating the substrate obtained in step (c) into a secretion monitoring article.

BRIEF DESCRIPTION OF THE DRAWINGS

The invention is herein described, by way of example only, with reference to the accompanying drawings.

FIGS. 1A-B are schematic top views of an embodiment of the secretion-monitoring article of the present invention with magnification of details of indicators applied to the substrate.

FIG. 2 is a schematic top view of a different embodiment of the secretion-monitoring article of the present invention.

FIG. 3 is a schematic perspective view of a different embodiment of the secretion-monitoring article of the present invention with a microporous membrane.

FIG. 4A-C are schematic top views of an embodiment of the secretion-monitoring article with two pH indicators.

FIGS. 5A-B are schematic top views of an embodiment of the secretion-monitoring article with one pH indicator device that can distinguish between urine and other body fluids, such as amniotic fluid.

FIG. 6 is a graph showing the change in color of the polymer vs. the change in pH, wherein the color scale conversion is as follows: 0-Yellow; 1-Light Green; 2-Green; 3-Dark green.

FIG. 7 is a graph demonstrating the buffering capacity of vaginal secretions.

The graph compares the pH of the butter or secretion being titrated to the mL NaOH 0.1 M added.

DETAILED DESCRIPTION OF THE PREFERRED EMBODIMENTS

Before turning to details of the present invention, it should be appreciated that the present invention provides secretion-monitoring article and a method for use thereof that allows an untrained user to monitor secreted biological fluids with confidence. The present invention allows for the identification of a specific biological fluid even when there is a possibility for the presence of an interfering biological fluid with a similar pH. The present invention further teaches an indicating mixture and method of attaching the mixture to a substrate.

The present invention is an improvement over the prior art, providing a secretion monitoring article that is more reliable and convenient for the user. The secretion-monitoring article of the present invention comprises an absorbent material for absorbing a biological fluid secreted from a person and an indicator system that has an indicator agent that identifies the pH associated with the secretion. The indicator system is associated with an absorbent material such that the biological fluids absorbed by the absorbent material further contact the indicator system so that a reliable indication of the pH of that fluid can be obtained. The indicator system may provide a visible indication of pathological conditions, wherein the visual indication is stable for about a week.

The terms "stable indication" and "irreversible indication" are interchangeably used herein to describe an indication, typically a color indication, that once obtained remains

sufficiently altered for a time sufficient for clinical examination by a professional. Preferably the color change is stable for at least 48 hours, more preferably at least 72 hours, and in some embodiments, preferably the color change is stable for about a week.

In one embodiment of the invention, the secretion-monitoring article comprises a body that includes an absorbent material for absorbing a biological fluid secreted from a person and an indicator system comprising an indicator agent that reacts with biological fluid differently. One example of such an indicator agent is a composition that reacts with fluids containing protonated amine cations, such as urine, in a different way than it reacts to other biological fluids that have a low concentration of protonated amine cations, such as amniotic fluid.

In another embodiment of the invention, the secretion-monitoring article comprises a body that includes an absorbent material for absorbing a biological fluid secreted from a person and an indicator system comprising an indicator mixture that reacts with normal urine differently than infected or protein containing urine. In one non-limiting

example, the indicator reacts with normal urine (pH 5-8), which changes the color from yellow to green or turquoise. During the drying process the color change of the indicator that has been contacted with normal urine fades as it dries and becomes yellow again. In contrast, when the indicator is contacted by infected or protein containing urine the indicator strip changes color from yellow to green or turquoise and does not fade when dried. Advantageously, this embodiment is well suited for all types of use, for example in pediatrics, geriatrics, and gynecology, and could be presented to the user in many forms, preferably as a diaper or a panty liner.

The secretion-monitoring article can be implemented using many devices and methods. In a preferred embodiment, the article of the present invention is implemented in a manner that can be easily used by non-skilled personnel, specifically a user. The body of the secretion-monitoring article of the present invention comprising the absorbent material can be supplied to the user, for example, in the form of a pad, gauze, a swab, a fiber ball, but most preferably, as a sanitary napkin, diaper, panty shield, and interlabial structure. Details of manufacture of these are well known to one skilled and have been fully described in the prior art, for example U.S. Pat. Nos. 5,217,444, 5,897,834, and 6,149,590.

Furthermore, any user, male or female, young or old, can use the article in a variety of forms. The particular examples of the invention as presented herein are not intended to limit the scope of the invention, but simply to illustrate and represent the numerous potential forms in which the invention can be used.

Preferably the indication system comprises an indicator mixture as described herein below. As will be discussed in more detail below, more than one indicator systems can be part of the indicator system. The indicator system should be capable of determining substantially different pH ranges, buffer capacities, or capable of reacting differently to different biological fluids to produce a different color change.

The term "substantially different pH ranges" is to be construed in its most general sense and refers to any pH ranges that do not span exactly the same range. Namely, pH ranges having different upper limits and/or different lower limits are substantially different. These different pH ranges may comprise overlapping pH values, such as a pH range of 5.0-8.0 and a pH range of 4.0-7.0 and may be also essentially different, namely, devoid of any overlapping pH values.

In yet another embodiments of the secretion-monitoring article, a means for mounting the article to facilitate the collection of the secreted biological fluid is included. An example of a mounting means that is well known in the art is an adhesive strips associated with the article. In a preferred embodiment the article has one or more adhesive strips. The user removes the release tape to expose the adhesive strip of the article and places the article in the crotch portion of their undergarment. This prevents the article from moving out of position during regular use. Types of adhesive compounds that can be used are well known in the art.

The present invention will be exemplified by embodiments of the secretion-monitoring article of the present invention in the form of a panty shield as presented in FIGS. 1-5. The article can be configured to identify amniotic fluid and secretions associated with bacterial, parasite, fungal, or yeast infection, such as infected urine or vaginal secretions. Furthermore, the article is designed to minimize false positive readings associated with interfering biological fluids.

In some embodiments, the article further comprises a second pH indicator chosen so that it indicates the change of pH as a result of the reaction with a reagent. For example, second indicator in FIGS. 1A-B is m-cresol purple. m-cresol purple is yellow at a pH of below 7.5 and is violet at a pH above 8.0. The second indicator and the reagent are applied at second area 16 on substrate 14, distinct from the first area 12 on substrate 14, FIG. 1A.

In FIG. 1B, amniotic fluid 18 comes in contact with panty shield 10. Amniotic fluid 18 makes contact with first area 12 and second area 16. As the pH of amniotic fluid 18 is between 7.0 and 7.5, the nitrazine yellow present at first area 12 become blue violet, spelling out the word "AMNIO". It is clear to one skilled in the art that if a small amount of fluid is applied to panty shield 20, it is possible that only part of first area 12 will change color. The m-cresol purple present at second area 16 remains yellow.

When the user of panty shield 20 in FIG. 1B examines panty shield 10, she reads the word "AMNIO" and can go to a health-care professional who can take action corresponding to a high degree of certainty of amniotic fluid secretion.

It is clear to one skilled in the art that arranging first area 12 and second area 16 so as to spell out words is not necessary, and in alternative embodiments of the present invention first area 12 and second area 16 may have any shape. For example, in FIG. 2, a panty shield 26 configured in accordance with the present invention is depicted where each one of first area 28 is of substantially circular shape and each one of second area 30 is substantially square shaped.

When used in a medical setting, it is imperative that there be substantially no leaching of indicator system components from the substrate to which the indicator system is attached. The attachment of indicators to a substrate is well within the ability of one skilled in the art. One family of chemical compounds that are suitable for use as the indicators of the present invention without leaching are indicators with negative functional groups. Suitable indicators include nitrazine yellow, thymol blue, bromthymol blue, xylenol blue, bromoxylenol blue, phenol red, m-cresol purple, chlorophenol red, bromcresol purple, alizarin, neutral red, and cresol red, see Table 1. A list of other suitable indicators can be found, for example, in U.S. Pat. No. 5,897,834. It is clear to one skilled in the art that the indicators specifically mentioned herein are just examples and any suitable indicators may be used. Further, there may be instances where the first indi-

cator and/or the second indicator are made up of a combination of individual indicators.

TABLE 1

Indicator	aqueous pH transition range	color change	CAS
1. Cresol Red	7.2-8.8	yellow to reddish purple	1733-12-6
2. Alizarin	5.5-6.8	yellow to violet	72-48-0
3. Bromcresol Purple	5.2-6.8	yellow to purple	115-40-2
4. Chlorophenol Red	5.2-8.8	yellow to red	4430-20-0
5. Nitrazine Yellow	6.0-7.2	yellow to bright blue	5423-07-4
6. Bromthymol Blue	6.0-7.6	yellow to blue	34722-90-2
7. Bromoxylenol Blue	6.0-7.6	yellow to blue	40070-59-5
8. Neutral Red	6.8-8.0	red to yellow	553-24-9
9. Phenol Red	6.8-8.2	yellow to red	34487-61-1
10. Thymol Blue	8.0-9.2	yellow to blue	81012-93-3
11. Xylenol Blue	8.0-9.6	yellow to blue	125-31-5
12. m-Cresol purple	7.4-9.0	yellow to purple	2303-01-7

Another non-limiting embodiment of the indicator system of the present invention is a secretion-monitoring article for the identification of vaginal infections such as bacterial vaginosis (BV) or parasitic. According to the present invention, an indicator system is made with a first indicator agent that indicates the presence of a fluid with a pH of around 4.7 to 7.0. The first indicator agent can be chosen, for example, from one or more of the group including nitrazine yellow, bromthymol blue and bromoxylenol blue. As can be seen in Table 1, these three indicators typically exhibit a bluish color when exposed to a fluid with a pH above 7.0. The second indicator can be chosen, for example, from the group including phenol red, thymol blue, xylenol blue and m-cresol purple. As can be seen in Table 1, upon exposure to a fluid with a pH above 8.0 these four indicators become reddish-purple, red, blue and violet.

As discussed hereinabove, urine of a healthy patient has a pH between 5.0 and 8.0. A patient having BV or parasite also has vaginal secretions with a pH between 4.7 and 6.5. If the liquid examined in the second embodiment of the secretion-monitoring article of the present invention is associated with BV or parasite, the indicator changes color.

The following examples set forth preferable embodiments of the present invention.

EXAMPLE 1

Reducing Erroneous Readings of Color-Changing Devices that Give an Indication of Elevated pH in the Vaginal Secretion

The following example discloses the solution to produce an indicator that needs no color-table or scale to read results, that shows the user a stable indication for a few days, and that does not leach even when in contact with liquids for any practical length of time. For the non-invasive continuous monitoring version, the invention discloses a solution to avoid false positive readings due to urine contamination.

The device is a sticker or a pantyliner that contains two different indicator strips, embedded between layers of one-way absorbent tissues. The two indicators have a color transition-point at different pH levels. The color-reactions of the two indicators also have different reversibility in vaginal secretion Vs urine.

The first indicator strip changes color to stable blue, when sensing elevated pH in vaginal secretions (pH strip). The pH

strip contains the pH indicator-nitrazine-yellow, which has a pKa of 6.6 in aqueous solution, and with the innovative specific composition, changes the color when the vaginal secretion has a pH level of 5.0 or higher (the same innovative specific composition produces indicators for various pH levels, by using other negatively-charged members of the ionizable phenol group).

In a case where vaginal secretion with elevated pH (5.0-7.0) will reach the strips only the pH strip will change color and the change will remain stable for a few days.

Method of Preparation

(1) pH Strip:

Step 1: To a 10 ml of Acetone add 150 mg Cellulose acetate, 107 μ l Dibutylphthalate, 23 μ l Aliquat, 150 μ l 2-Ethoxy ethanol and 2.4 mg nitrazine yellow dissolved in 150 μ l DDW.

Step 2: Stir the mixture for few minutes to complete dissolving.

Step 3: Coat a polyester monofilament screening fabric with the polymer solution (coating other materials insensitive to acetone will produce various devices for various using instructions, with the same features).

(2) Urine Strip:

First layer-step 1: To a 4.15 mL DDW add 45 mg PVP, 0.325 mL urease/glycerol solution.

First layer-step 2: Coat a polyester monofilament screening fabric with the polymer solution.

First layer-step 3: The coated strips are dried-out over night at room temperature.

Second layer-step 1: To a 10 ml of THF add 150 mg Cellulose acetate, 107 μ l Dibutylphthalate, 23 μ l Aliquat, 150 μ l 2-Ethoxy ethanol and 1.2 mg m-Cresol purple dissolved in 120 μ l 1-Propanol.

Second layer-step 2: Stir the mixture for few minutes to complete dissolving

Second layer-step 3: Coat the strip with the second polymer solution.

Second layer-step 4: After drying over night the wash the strip in a saline solution.

The device can be in the form of a swab with a tip produced in the same way as mentioned above, under the header: pH strip. The tip may be prepared by using a short strip, rolled on the stick of the swab, or by coating the tip of an integrated swab (implementing step 3), where the tip consists of any screening fabric.

EXAMPLE 2

A Device Able to Distinguish Accurately Between an Amniotic Fluid Leak or an Elevated pH Vaginal

Discharged Secretion and Wetness Caused by Urine Incontinence

Due to the severe consequences of amniotic fluid leakage, pregnant women undergo heavy stress and tend to seek for a health care provider upon any wet sensation in the area of

the vagina. The common ways to checks for the presence of amniotic fluid are by examining the pH of vaginal secretions with pH indicators such as nitrazine indicators, running the Fern-test or by visually identifying the source of the leakage.

Amniotic fluid has a pH level that varies between 6-8 and can be identified by a purple-blue color of a nitrazine indicator. Since urine, has a pH level that varies between 5.0-8.0, measuring pH levels as a sole criterion can mislead to erroneous decisions. As the other two ways can be performed only in clinics and hospitals, and by trained staff, there is no practical solution for home monitoring.

In some situation, after amniocentesis tests and other occasions such as hi-risk pregnancies, there is a possibility of small amniotic leaks that can be detected only by continuous monitoring.

Current solutions and earlier inventions fail to serve as a home-use continuous monitoring device, as they leach in fluids, the color change is unstable, and the overlap between amniotic fluid pH level and the urine pH level misleads the users in as 30% of the cases.

The overlap of pH levels, between amniotic fluids and urine is also a great disadvantage for physicians treating patients with wet sensations. Providing pregnant women with a home-use continuous monitoring device, that distinguishes amniotic fluid leakage from urine incontinence with no false alarms, enabling the result reading at personal timing and discretion, and detects any small amniotic leak instantaneously, can on one hand help bring the user in-time to hospital when needed, and on the other hand avoid unnecessary hospitalization and concomitant patient stress.

Providing physicians with a reliable clinic instantaneous detecting article, that distinguishes amniotic fluid leakage from urine incontinence with no false alarms, can serve them by far better than available solutions today.

The article can be a sticker or a pantyliner with an embedded indicator strip. The strip contains the pH indicator-nitrazine-yellow which has a pKa of 6.6 in aqueous solution.

Reaction of the indicator with amniotic fluid (pH 6-8) changes the color from yellow to stable dark blue. Reaction of the indicator with urine (pH 5-8) changes the color to fading green or fading turquoise. Urine with lower pH 5-5.5 does not change the indicator color.

The difference between the color reaction of the indicator with amniotic fluid and with urine consists of two parameters: the chemical composition of the fluids and the indicator's polymer chemical structure.

The following two equations demonstrates the different reactions:

Equation 1:

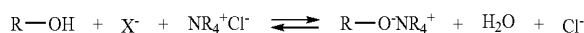

Equation 2:

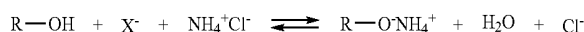

60

KEY:

X⁻=Base

NR₄⁺=Ion balance reagent

R-O⁻NR₄⁺=phenolate-ion balance reagent

The ratio of ion-balance reagent versus indicator in the polymer matrix controls the transition point of the color and

65

the color stability while drying. In the drying process the ion pair phenolate (the active site of the indicator)-ion-balance reagent is stable, which cause a stable performance of the color (equation 1—the relative concentration of the component does not change). In a different case where the concentration of the ion-balance reagent in the polymer is higher, the color of the indicator is getting dark while drying. The color darkening while drying is due to continuance deprotonation of the indicator's phenol by the basic excess of the ion balance reagent (equation 1—while drying the base concentration is getting high and the equilibrium turned to the right). The optimum molar ratio of ion-balance reagent to indicator is 10:1.

Ammonium ions in solution react like the ion-balance reagent and compete with the phenolate active site. While drying the ion pair phenolate-Ammonium hydrolyzed spontaneously to give the protonated yellow phenol (equation 2) while the phenolate-ion-balance reagent pair is stable (equation 1).

In a case where the medium contain ammonium ion the color changes govern by the relative concentration of the ion balance reagent in the polymer and the ammonium ion in the medium.

For example: in 100 mM buffer solution that contains 25 mM ammonium ion the concentration of the ammonium is in two orders of magnitude higher than the ion balance reagent in the polymer. These differences govern the turquoise color in solution and the fading color on drying.

Urine contains ammonium ions in concentration of 30-50 mM; amniotic fluid doesn't contain any substantial amount of ammonium ions, thus causing no fading influence as urine does.

Method of Preparation:

Step 1: To a 10 ml of Acetone add 150 mg Cellulose acetate, 107 μ l Dibutylphthalate, 23 μ l Aliquat, 150 μ l 2-Ethoxy ethanol and 2.4 mg nitrazine yellow dissolved in 150 μ l DDW.

Step 2: Stir the mixture for few minutes to complete dissolving.

Step 3: Coat a polyester monofilament screening fabric with the polymer solution to give the desired product.

The device can be a swab with a tip produced in the same way as mentioned above, under the header: pH strip. The tip may be prepared by using a short strip, rolled on the stick of the swab, or by coating the tip of an integrated swab (implementing step 3), where the tip consists of any screening fabric.

EXAMPLE 3

A Device Able to Distinguish Accurately Between Normal Urine and Infected Urine

The reoccurrence of urinary tract infections in certain patients present the need to quickly and easily diagnose whether the patient has another urinary tract infection. Presently, to determine if a patient has a urinary tract infection they must make an appointment to visit a doctor. Furthermore, if the patient is susceptible to the reoccurrence of urinary tract infections they must make periodic visits to the doctor's office to ensure that the infection has not reoccurred. Having a device that would allow the user to determine if they had a urinary tract infection again would minimize stress and time consumed by visits to the doctors office and result in quicker diagnosis of the infection, resulting in a reduction in pain suffered by the patient and a more timely treatment of the infection.

The article in this example is a diaper or a panty liner with an indicator that can distinguish between normal urine and infected urine. The user wears the article so that urine can come in contact with the article. The reaction of the indicator with urine (pH 5-8) changes the color from yellow to green or turquoise. The drying process of the indicator strip at room temperature is short (5 minutes). When normal urine comes in contact with the indicator strip the color changes fade while drying. The color change is completely reversible and the strip becomes yellow again. On the other hand when infected urine comes in contact with the indicator strip the color changes to green or turquoise and stay constant while drying.

The reversibility of the color changes depends on two different environmental factors:

1. Chemical environment:

- (a) The pH level of the fluid-pH level higher than the pKa gives a stable color change.
- (b) Buffer capacity of the solution explained extensively in EXAMPLE 4.
- (c) Ammonium salts content in the solution-explained extensively in EXAMPLE 2.

2. Biological environment:

- (a) Protein presence in urine gives a stable color change and the reaction is not reversible.

Infected urine provides a stable color change to the indicator, which color change is not reversible. Furthermore, bacteria presence in vaginal secretion fluid also gives a stable color change so that the color change is not reversible.

EXAMPLE 4

A Device Able to Distinguish Between Bacterial or Parasitic Infected Secretions and Normal or Candida Vaginal Secretions. Advantageous Attributes of Polymer Matrix Compared to Commercially Available pH Indicator Paper

The buffering capacity of vaginal secretions was studied. In view of these findings the chemical attributes of the polymer matrix of the invention compared to commercially available pH indicator paper were also studied. It was determined that because of the high quantity of homogenous secretions typical of BV, that vaginal secretion associated with BV have a low buffer capacity due to transudation of extracellular fluid.

Bacterial vaginosis (BV) is characterized by production of increased quantities of malodorous vaginal discharge. The vaginal discharge of women with BV is described as being thin (low viscosity), off-white-gray (milk-like consistency), and homogeneous (distinctly not curd-like).

In the vagina there are no glands so that the fluid which it contain results from cervical secretion, vulvar secretions from sebaceous, sweat, Bartholine and Skeens glands, exfoliated cells, endometrial and oviductal fluids but mainly from liquid transudation through the vaginal epithelial walls.

As mentioned above, one of the characteristic of BV is the homogeneous discharge. A women having BV typically has an increase in the discharge amount. The source of this liquid is extracellular fluid (interstitial fluid) that surrounds the epithelial cells in the vagina wall.

The ionic composition of the extracellular fluid and the plasma is quite similar with some differences reflecting the inability of large solutes, like proteins, to cross the cells wall.

A decrease in protein levels and other large organic molecules and the increase of water content in BV secretions

lowers the buffering capacity of the secretions. Thus, secretions associated with BV have a lower buffer capacity than healthy vaginal secretions.

Experimental and Results

Polymer Color Change in Solution:

TABLE 2

Color change of polymer mixture dependent on pH					
PH (± 0.05)	100 mM	50 mM	20 mM	10 mM	5 mM
4.0	0	0	0	0	0
4.3	0	0	0	0	1
4.5	0	0	0	1	1
4.7	0	0	1	1	2
5.0	1	1	1	2	2
5.2	1	1	2	2	2
5.5	2	2	3	3	3

*Color scale conversion: 0—Yellow; 1—Light Green; 2—Green; 3—Dark green;

A follow-up experiment was done using commercially available nitrazine Paper (APOTHECON Inc., Princeton, N.J.) with the same regime of pH buffer solutions. The nitrazine Paper did not significantly change color in any of the pH buffer solutions. The results indicated that the commercially available nitrazine paper sensitivity was insufficient to indicate a color change significant enough to distinguish and identify the difference in pH of any of the measured solutions.

It is known that nitrazine yellow is a weak acid pH indicator, which when dissolved in water dissociates slightly and form the conjugate base:

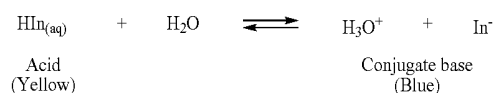

It is clear from the results (Table 2; FIG. 6) that when the buffer capacity of the solution is lower the color change occurs at a lower pH. The variation between the first color change in the 5 mM buffer solution is approximately 0.7 pH units lower than the first color change of the 50 mM buffer solution.

This is achieved in the polymer matrix of the invention indicator because of its unique formulation. The nitrazine yellow (NY) environment in the polymer matrix is hydrophobic, composed of electronic neutral organic substrate except of the ion balance reagent that does not contribute to the acid-base balance. In contrast, the chemical composition of the commercial nitrazine Paper is a hydrophilic formulation that contains some degree of ionic buffer.

The mechanism of the color changes of the polymer matrix is described in the following equation:

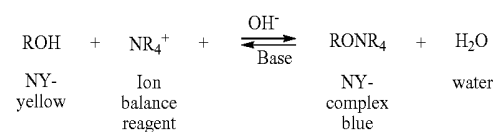

The reaction is in equilibrium and the color of the polymer depends on the ratio of free NY compared to the NY complex.

In solution the color change is governed by the pH and the buffer capacity. On the drying process of the polymer matrix, the NY complex dissociates easily when the buffering system is highly concentrated or when there is high concentration of protonated cations like NH_4^+ in urine. The dissociation of the complex occurs due to the basic nature of the phenolate ion in the NY complex and the high concentration of protons compare to the Ion balance reagent. The dissociation of the complex express in color changes from green or blue to yellow. On the other hand when the buffer is weak or the medium is highly watery the NY-complex stay stable at any color including the light green one. The stability of the color is due to the lack of protons compared to the Ion balance reagent concentration.

Assessment of Buffer Capacity of Vaginal Secretion:

In order to examine the buffer capacity of vaginal secretions, different buffer solutions were titrated with 0.1 N NaOH in comparison with vaginal secretions.

The vaginal secretions were collected with a sterile swab. The sterile swab was weighted on an analytical balance before and after secretion sampling. The secretion was then diluted in double distilled H_2O and titrated as the other buffer solutions with NaOH 0.1M. The dilution factor was taken in account in determining the buffer capacity of the vaginal secretion. The results of the titrations are summarized in FIG. 7.

This study validates that the nature of color changes of the polymer matrix of the invention has an advantage compare to commercial nitrazine paper or devices based on nitrazine paper in detecting infection which has low buffer capacity characteristics. For example infected vaginal secretion with pH levels of 4.3-4.9 and low buffer capacity will be detected by the polymer of the invention while will not be detected by commercial nitrazine paper.

Improved Methods for Attaching Indicators to a Substrate

Details and variations concerning the method of manufacture of a secretion-monitoring article for implementing the indicator system of the present invention or applying the method of the present invention are well described in the prior art.

As described hereinabove, U.S. Pat. No. 5,897,834 describes a solid pre-formed polymer to which quaternary ammonium groups are covalently bound. Negatively charged-indicators are non-covalently bound to the polymer. The non-covalent bonds are strong enough so that the attached indicators do not leach out in an aqueous solution. In addition, the indicators bound to the polymer have a sharpened pH color transition, allowing an accurate determination of the pH of the applied fluid. The polymer can be applied to various substrates. However, indicators bound to these polymers are less useful in non-clinical settings as the indicated pH of vaginal secretions after drying is lower than that of fresh vaginal secretions, leading to false positive results.

In the present invention is disclosed a method suitable for attaching indicators to a substrate so that the indicators do not leach out in an aqueous fluid. Especially suitable indicators are those with a negatively charged group, such as those listed in Table 1 or, for example, in U.S. Pat. No. 5,897,834. The polymer of the present invention is exceptionally suited for attaching the indicator system of the present invention to a substrate. Further, experiments show that unlike other methods and polymers known in the art, changes in color of indicator attached according to the methods of the present invention are fast. The color is retained over a long period of time, as detailed in Example

7, and even when the applied liquid dries. Repeated cycles of drying and wetting also do not change the color. Thus, in practical terms, there is time for a user to get to a health care professional without the color of the indicator changing.

Application of Indicator to a Substrate.

In a first embodiment of the method of the invention for attaching an indicator to a substrate, an indicator is mixed with a preformed polymer in a suitable solution and then applied to a substrate.

In more detail, a polymer solution is prepared containing dry pre-formed polymer, plasticizer, a wetting agent, an ion-balance reagent, a solvent and an indicator. When practicing the method of the present invention, a reagent as described is also added.

The preformed polymer can be selected from various preformed polymers, although cellulose polymers such as nitrocellulose, cellulose acetate or ethyl cellulose are preferred. The preformed polymer makes up 20% to 50% of the weight of the solution. In certain embodiments, the polymer makes up 25% to 45% of the solution. In other embodiments, the polymer makes up 30% to 43% of the solution. In yet other embodiments, the polymer makes up 36% to 39% by weight of the solution. As is clear to one skilled in the art, it is also possible to use a combination of suitable preformed polymers when making one polymer solution.

Although any suitable plasticizer can be used bis-(2-butoxyethyl)adipate (BBPA, CAS 141-18-4), bis-(2-ethylhexyl)sebacate (DOS, CAS 122-62-3), diethyl phthalate (DEP, CAS 84-66-2) or dibutyl phthalate (DBP, CAS 84-74-2) are preferred. The plasticizer makes up 15% to 40%, 20% to 35%, 25% to 31%, 27% to 29% by weight of the solution. As is clear to one skilled in the art, it is also possible to use a combination of suitable plasticizers when making one polymer solution.

Although any suitable wetting agent can be used, triethylene glycol, ethylene glycol, sorbitol or 2-ethoxy ethanol are preferred. The wetting agent makes up 15% to 45%, 21% to 40%, 26% to 34% and 29% to 31% by weight of the solution. As is clear to one skilled in the art, it is also possible to use a combination of suitable wetting agents when making one polymer solution.

Although any suitable ion-balance reagent can be used, tricaprilylmethyl ammonium chloride (Aliquat 336; CAS 5137-55-3), tridodecylmethyl ammonium chloride (TDMAC; CAS 7173-54-8) or cetyltimethyl ammonium chloride (CTAC; CAS 112-02-7) are preferred. The ion-balance reagent makes up 0.1% to 10%, 1% to 8%, 3% to 7% and 4% to 6% by weight of the solution. As is clear to one skilled in the art, it is also possible to use a combination of suitable ion-balance reagents when making one polymer solution.

The components of the solution are added so that the sum of weights of pre-formed polymer, plasticizer, wetting agent and ion-balance reagent is equal to 100%.

The desired indicator is added to the solution. Although any suitable indicator can be used, it is preferred that the indicator molecules have a negatively charged functional group such as acetate or sulfonate. Most preferably, the indicators used, separately or in combination, are chosen from amongst indicators listed in Table 1 and in U.S. Pat. No. 5,897,834. The total amount of indicator added is 0.05% to 5%, 0.05% to 3%, 0.1% to 1% and 0.2% to 0.4% of the weight of the polymer solution.

Further, an amount of solvent is added that is suitable for making any easily applied solution/indicator mixture. Typically, 150 mg of polymer solution is dissolved in between 1 ml and 30 ml of solvent or 5 ml and 15 ml solvent. Although

any suitable solvent or mixture of solvents may be used, preferred are ethyl acetate or substantially volatile ethers such as diethyl ether, isopropyl ether, t-butyl methyl methyl ether or tetrahydrofuran.

Once the mixture is ready, it is applied by suitable means to the substrate. Application can be done, for example, by spraying or spreading the mixture on the substrate, or by dipping the substrate in the mixture. The substrate can be of many suitable woven or non-woven materials known in the art such as polyester membranes, polypropylene membranes, cellulose membranes, paper, cotton or linen. The structure of the substrate may be, for example, a fiber, a mesh, gauze, a fabric or a membrane. The solvent of the mixture is allowed to evaporate. Once the mixture dries onto the substrate, the substrate is integrated into whatever secretion-monitoring article is desired, such as a panty shield.

As is clear to one skilled in the art that when the indicator system of the present invention is implemented, a first mixture with a first indicator is made, and a second mixture with a second indicator and a reagent is made, both mixtures as described hereinabove. Each of the two mixtures is applied to a predefined area on the substrate, as described hereinabove. Preferably the area of application of the first mixture is substantially distinct from the area of application of the second mixture.

In certain applications, the liquid to be tested may contain biological polymers such as proteins or fats. For example, amniotic fluid and urine often contain proteins. The biological polymers may plug up the pores in the substrate reducing the effectiveness of the testing method. This can be exceptionally significant in panty shield applications such as panty shield **32** depicted in FIG. **3**. In such cases, it is preferable to interpose a microporous membrane **34**, such as a dialysis membrane (e.g., cellulose membrane, catalog no. D-9402, Sigma-Aldrich, St. Louis Mo.), between indicator substrate **36** and a source **38** of secretion **40**. Large-sized materials **42** in secretion **40** cannot penetrate microporous membrane **34** whereas fluid component **44** of secretion **40** penetrates microporous membrane **34** to react with indicator substrate **36**. Panty shield **32** in FIG. **3** further includes two side flaps **46** (only one is visible in FIG. **3**) configured to allow attachment of panty shield **32** to an undergarment of a user, in such a way keeping panty shield **32** in the proximity of the vagina of a user.

In a second embodiment of the method of attaching an indicator to a substrate according to the present invention, a substrate is first treated with a surfactant solution. After the solution dries, an indicator solution is applied to the substrate. The substrate can then be integrated into a product.

Although any surfactant can be used, when it is desired to attach negatively charged indicators to a neutral substrate, a surfactant with a cationic functional group is used, preferably Aliquat 336, TDMAC or CTAC. Although any suitable solvent or mixture of solvents may be used, preferred are ethyl acetate or substantially volatile ethers such as diethyl ether, isopropyl ether, t-butyl methyl ether or tetrahydrofuran. The surfactant is dissolved in the solvent at any suitable concentration. Preferred is that the surfactant makes up 0.01% to 2% of the solution, more preferred is that the surfactant makes up 0.1% to 0.5% of the solution, and most preferred is that the surfactant makes up 0.15% to 0.25% by weight of the solution.

As is clear to one skilled in the art, it is also possible to use a combination of suitable surfactants. The surfactant solution is applied to the substrate. Application is done, for example, by spraying or spreading the mixture on the substrate, or by dipping the substrate in the mixture. The

substrate can be of many suitable materials known in the art such as polyester membranes, polypropylene membranes, cellulose membranes, paper, cotton or linen. The structure of the substrate may be, for example, a fiber, a mesh, gauze, a fabric or a membrane. The solvent of the surfactant solution is allowed to evaporate. Although the solvent may be allowed to evaporate at ambient pressure, it is preferable to evaporate the solvent under vacuum, preferably at a pressure of less than 600 mm Hg, more preferably less than 200 mm Hg, and even more preferably less than 100 mm Hg.

After the solvent of the surfactant solution has evaporated, an indicator solution is applied to the substrate. Although any solvent or mixture of solvents may be used, preferred are ethyl acetate or substantially volatile ethers such as diethyl ether, isopropyl ether, t-butyl methyl ether, or tetrahydrofuran. Although any suitable indicator can be used, it is preferred that the indicator molecules have a negatively charged functional group such as acetate or sulfonate when the surfactant used is a cationic surfactant. Most preferably, the indicators used, separately or in combination are chosen from amongst those listed in Table 1 or, for example, in U.S. Pat. No. 5,897,834. The amount of indicator added is 0.00001% to 1% of the weight of the indicator solution as described above. Preferred is that the indicator is 0.0001% to 0.1% of the indicator solution, more preferred is that the indicator is 0.001% to 0.01% of the indicator solution, and most preferred is that the indicator is 0.002% to 0.004% of weight of the indicator solution.

When it is desired to add a reagent in preparation of the indicator system of the present invention, reagent is added to the indicator solution. For example, when urease is used, any suitable amount of urease can be added. Although any suitable concentration of urease can be used, preferred is a concentration of between 1 and 100 unit/ml. More preferred is a concentration of 2 and 50 unit/ml and even more preferred a concentration of 5 and 20 unit/ml.

In an additional embodiment of the present invention, a reagent solution is prepared separately from the indicator solution. When urease is used as a reagent, any suitable concentration of urease can be used. It is preferred that a concentration of between 1 and 100 unit/ml urease be used, more preferred is a concentration of 2 and 50 unit/ml and even more preferred a concentration of 5 and 20 unit/ml.

The indicator solution (or indicator/reagent solution) is applied to the substrate. Application can be done, for example, by spraying or spreading the indicator solution on the substrate, or by dipping the substrate in the indicator solution. The solvent of the indicator solution is allowed to evaporate. Although the solvent may be allowed to evaporate at ambient pressure, it is preferable to evaporate the solvent under vacuum, preferably at a pressure of less than 600 mm Hg, more preferably less than 200 mm Hg, and even more preferably less than 100 mm Hg.

100 mM buffer phosphate citrate was prepared with seven different pH values. Each buffer was diluted to four different concentrations: 50, 20, 10 and 5 mM and the pH was adjusted using NaOH 1M or HCl 1M. A nitrazine polymer matrix of the invention was dipped in each buffer and the change in color was noted and represented by a numeric values as follows: 0=Yellow; 1=Light Green; 2=Green; 3=Dark green. The results are summarized in Table 2 and FIG. 6.

When a reagent solution is prepared separately from the indicator solution, the reagent solution is applied in substantially the same way as described hereinabove, either before or after application of the indicator solution.

Irrespective of the exact concentration of the indicator solution and of the surfactant solution used, it is preferable to apply an amount of each one of the solutions so that the molar concentration of surfactant applied per unit area of substrate is roughly one hundred times greater than the molar concentration of indicator applied per unit area of substrate. The indicator solution is applied to the substrate to areas where surfactant was previously applied.

As is clear to one skilled in the art, when the indicator system of the present invention is implemented, a first solution with a first indicator is made, and a second solution with a second indicator and a reagent is made, both solutions as described hereinabove. Each of the two solutions is applied in distinct areas on the substrate, as described hereinabove.

EXAMPLE 5

Stability of Indication I

Solution A: 370 mg cellulose acetate, 280 mg DBP, 150 mg sorbitol, 150 mg 2-ethoxyethanol, 50 mg TDMAC were combined. 3 mg Bromthymol blue were added, 20 ml THF were added. The solution was vigorously stirred.

Solution B: 370 mg cellulose acetate, 280 mg BBPA, 300 mg ethylene glycol, 50 mg TDMAC were combined. 3 mg m-cresol purple and 30 units urease were added. 20 ml 20 THF were added. The solution was vigorously stirred.

Solution C: 10 mM buffer Citrate Phosphate solution at different pH values ranging from 3.0 to 7.0. The 10 mM buffer solution was obtained by diluting 100 mM buffer solution. The different pH levels are result of mixtures at different ratios between the buffer components (100 mM Citric acid and 200 mM dibasic Sodium Phosphate) adjusted to the final pH values with 1M Hydrochloric Acid or 1M Sodium Hydroxide solutions.

Solution D: 0.1% BSA in double distilled water and pH 4.5 adjusted to the final pH values with 1M Hydrochloric Acid or 1M Sodium Hydroxide solutions.

(1a) Cotton gauze was dipped in Solution A. When the solution dried, the cotton gauze was cut in half. The first half was dipped in a pH 7 test solution. The first half became purple. The first half was allowed to dry in ambient conditions, with no substantial change of color. After three hours, the second half was dipped in a pH 7 test solution. The second half became purple. The colors of the first half and of the second half were substantially the same.

(1b) Cotton gauze was dipped in Solution B. When the solution dried, the cotton gauze was cut in half. The first half was dipped in urine. The first half became violet. The first half was allowed to dry in ambient conditions, with no substantial change of color. After three hours, the second half was dipped in urine. The second half became violet. The colors of the first half and of the second half were substantially the same.

(1c) Solution A and Solution B were applied in alternating stripes on cotton gauze at a density of about 50 $\mu\text{l}/\text{mm}^2$. Amniotic fluid was applied to the gauze, changing the color of the stripes of Solution A to purple. Urine was applied to the gauze, changing the color of the stripes of Solution B to violet. The gauze was allowed to dry at ambient conditions for three hours and cut in half. Urine was applied to the first half. The colors of the stripes in the first half and the second half of the gauze were substantially the same.

(1d) Strips coated with solutions A or B were dipped in Solutions C and D of various pH values. A color change was observed in all strips. The intensity of the color of strips

dipped in Solution C was slightly reduced after 15 minutes of drying however the color maintained for at least 72 hours. The intensity of the color of strips dipped in Solution D was did not change after drying and for the next 72 hours.

Stability of Indication II

Product Preparation:

To a 10 ml of Acetone the following ingredients were added: 210 mg Cellulose acetate, 107 μ l Dibutylphthalate, 32 μ l Aliquat, 210 μ l 2-Ethoxy ethanol and 3.2 mg nitrazine yellow dissolved in 210 μ l DDW. All ingredients were dissolved by stirring the mixture for a few minutes. A polyester monofilament screening fabric was then coated with the polymer solution to give the desired product.

The stability of indication provided by the product of the invention was compared with the stability of indication provided by the following commercial pH indicating articles: nitrazine Paper (Apothecon) and Merck's pH-Indicator strips for pH ranges of 4.0-7.0. The color changes were compared to a reference PANTONE color guide catalogue and the results are summarized in Table 3. The test solutions which were used in this study consisted of 0.1% BSA in water (double distilled) at pH 5.5. The pH was adjusted with solutions of 1M Hydrochloric Acid or 1M Sodium Hydroxide solutions.

TABLE 3

Time	Stability of Indication		
	Indicator solution	nitrazine Paper (Apothecon)	pH Indicator Strip (Merck)
0	120	131	457
5 minutes	577	1245	457
1 hour	578	117*	456
2 hours	578	110*	456
24 hours	578	110*	4515*
48 hours	578	110*	4515*
72 hours	578	110*	4515*

*indicating incorrect pH values in comparison to manufacturer color scale.

EXAMPLE 6

Articles for Detecting Amniotic Fluids

Three solutions were prepared:

Solution A: 0.2% Aliquot 336 in DDW (double distilled water);

Solution B: 10 unit/ml urease and 0.003% m-cresol purple in DDW; and

Solution C, 0.003% nitrazine yellow in isopropyl ether.

A nitrocellulose membrane was dipped in Solution A and transferred to an atmosphere of 50 mm Hg. After 30 minutes, the membrane was removed from the vacuum. Solution B was applied in a pattern resembling the word "NO" at a density of 50 μ l/mm². Solution C was applied in a pattern resembling the word "AMNIO" at a density of 50 μ l/mm². The membrane was transferred to an atmosphere of 50 mm Hg. After 30 minutes, the membrane was removed from the vacuum. The membrane was dipped in a pH 7 test solution. The word AMNIO appeared in purple. After drying at ambient conditions for three hours, no substantial change of color was observed. The membrane was dipped in urine. The word NO appeared in violet.

Method of Constructing the Article

FIGS. 4A-C and 5A-B provide visual examples of two methods non-limiting examples of constructing the article.

FIGS. 4A-C show an article in the form of a panty shield 50 constructed with two indicators 52 and 54. In FIG. 4A, the panty shield 50 is constructed with a pH indicator 52 for detecting normal biological fluids and a second pH indicator with high pH dye and a reagent, such as urease, for detecting interfering biological fluids, such as urine. FIG. 4B depicts the panty shield 50 wherein a normal fluid, without an interfering fluid, changes the color 56 of the pH indicator 52. In contrast, FIG. 4C depicts the panty shield 50, wherein an interfering biological fluid, such as urine, changes the color 58 of the second pH indicator 54.

In a separate embodiment, the article can be made with only a single indicator as shown in FIGS. 5A and 5B. FIG. 5A depicts the article in the form of a panty shield 60, comprising a sticker 64, with an indicator 62 constructed so as not to react with an interfering biological fluid like urine. When a biological fluid to be detected comes in contact with the indicator, as show in FIG. 5B, the indicator changes color 66, whereas if the indicator comes in contact with urine it will not change colors.

The foregoing description of the specific embodiments will so fully reveal the general nature of the invention that others can, by applying current knowledge, readily modify and/or adapt for various applications such specific embodiments without undue experimentation and without departing from the generic concept, and, therefore, such adaptations and modifications should and are intended to be comprehended within the meaning and range of equivalents of the disclosed embodiments. It is to be understood that the phraseology or terminology employed herein is for the purpose of description and not of limitation. The means, materials, and steps for carrying out various disclosed chemical structures and functions may take a variety of alternative forms without departing from the invention. Thus the expressions "means to . . ." and "means for . . .," or any method step language, as may be found in the specification above and/or in the claims below, followed by a functional statement, are intended to define and cover whatever chemical structure, or whatever function, which may now or in the future exist which carries out the recited function, whether or not precisely equivalent to the embodiment or embodiments disclosed in the specification above, i.e., other means or steps for carrying out the same functions can be used; and it is intended that such expressions be given their broadest interpretation.

What is claimed is:

1. A secretion-monitoring article comprising a body that includes an absorbent material for absorbing a biological fluid secreted from a person and an indicator system having a hydrophobic chemical composition comprising an indicator agent and an ion-balance reagent, wherein the indicator system provides an indication of physiological conditions associated with the pH or the buffer capacities of the biological fluid, which indication is stable for at least 48 hours, wherein the ion-balance reagent is a quaternary amine.

2. The secretion-monitoring article of claim 1, wherein the ion-balance reagent is selected from the group consisting of: di(long-chain alkyl)dimethyl ammonium chloride, N-methyl-N,N-bis(long-chain alkanoyl oxyethyl)-N-(2-hydroxyethyl) ammonium methylsulfate, vinylbenzyl dimethylcocoammonium chloride, methyl trioctyl ammonium chloride tricapylylmethyl ammonium chloride, tridodecylmethyl ammonium chloride and cetyltrimethyl ammonium chloride.

3. The secretion-monitoring article of claim 1, wherein the indication is stable for at least 72 hours.

4. The secretion-monitoring article of claim 1, wherein the indicator system comprises two or more indicator mixtures.

5. The secretion-monitoring article of claim 1, further comprising mounting means for placing the absorbent body in a position to receive the biological fluid secreted from the person.

6. The secretion-monitoring article of claim 1, wherein the absorbent material is selected from the group consisting of: swab, gauze, panty shield, hygienic napkin, a diaper and interlabial absorbent structure.

7. The secretion-monitoring article of claim 1, wherein the indicator system irreversibly changes color for at least 48 hours when contacted by a vaginal secretion associated with vaginosis or amniotic fluid leakage.

8. The secretion-monitoring article of claim 7, wherein the indicator system reversibly changes color when contacted by urine.

9. The secretion-monitoring article of claim 1, wherein the indicator system comprises a preformed polymer in an amount of about 20% to 50%; a plasticizer in an amount of about 15% to 40%; a wetting agent in an amount of about 15% to 45%; an ion-balance reagent in an amount of about 0.1% to 10%; and an indicator agent in an amount of about 0.05% to 5%; wherein the percents are weight percent based on the total weight of the indicator system and the total weight of the indicator system equals 100% and the indicator system provides an indication of physiological conditions associated with the pH or the buffer capacities of the biological fluid, which indication is stable for at least 48 hours.

10. The secretion-monitoring article of claim 9, wherein: the pre-formed polymer is present in an amount of about 36% to 39%; the plasticizer is present in an amount of about 27% to 29%; the wetting agent is present in an amount of about 29% to 31%; the ion-balance reagent is present in an amount of about 4% to 6%; and the indicator agent is present in an amount of about 0.2% to 0.4%.

11. The secretion-monitoring article of claim 9, wherein the pre-formed polymer is a weakly acidic polyelectrolyte polymer.

12. The secretion-monitoring article of claim 11, wherein the pre-formed polymer is cellulose or a cellulose derivative.

13. The secretion-monitoring article of claim 11, wherein the pre-formed polymer is selected from the group consisting of: cellulose, sodium carboxymethyl cellulose, ethyl cellulose, nitrocellulose and cellulose acetate.

14. The secretion-monitoring article of claim 9, wherein the wetting agent is selected from the group consisting of: triethylene glycol, ethylene glycol, sorbitol and 2-ethoxy ethanol.

15. The secretion-monitoring article of claim 9, wherein the plasticizer is selected from the group consisting of: castor oil, diacetylated monoglycerides, diethyl phthalate, glycerin, mono- and di-acetylated monoglycerides, polyethylene glycol, propylene glycol, triacetin, triethyl citrate, bis-(2-butoxyethyl) adipate, bis-(2-ethylhexyl) sebacate and dibutylphthalate.

16. The secretion-monitoring article claim 9, wherein the pre-formed polymer is cellulose acetate in an amount of about 20% to 30%; the plasticizer is dibutylphthalate in an amount of about 10% to 20%; the wetting agent is an ethoxy ethanol polymer in an amount of about 20% to 30%; the ion reagent is a quaternary amine in an amount of about 1% to 10%; and the indicator agent is nitrazine yellow in an amount of about 0.05% to 5%; wherein the percents are weight percent based on the total weight of the mixture and the total weight of the mixture equals 100%.

17. The secretion-monitoring article claim 9, further comprising a solvent in an amount of about 1 to 30 ml of solvent for each 150 mg of pH indicator mixture.

18. The secretion-monitoring article of claim 1, wherein the ion-balance reagent and the indicator agent are present in amounts sufficient to provide a molar ratio that is within the range of 5:1 to 15:1.

19. The secretion-monitoring article of claim 1, wherein the biological fluid has a pH and the indicator agent has a pKa that provides a pH that is lower than the pH of the biological fluid, wherein the pH of the biological fluid is determined by a physiological condition.

20. The secretion-monitoring article of claim 19, wherein the indicator agent is negatively charged.

21. The secretion-monitoring article of claim 19, wherein the indicator agent is a weak acid.

22. The secretion-monitoring article of claim 19, wherein the indicator agent is selected from the group consisting of: cresol red, alizarin, bromcresol purple, chlorophenol red, nitrazine yellow, bromthymol blue, bromoxylene blue, neutral red, phenol red, thymol blue, xylene blue and m-cresol purple.

* * * * *

专利名称(译)	分泌物监测文章		
公开(公告)号	US7314752	公开(公告)日	2008-01-01
申请号	US11/105438	申请日	2005-04-14
[标]申请(专利权)人(译)	KRITZMAN阿姆农 Nachshon尼察G YAEL贝沙尔		
申请(专利权)人(译)	KRITZMAN阿姆农 Nachshon尼察G YAEL贝沙尔		
当前申请(专利权)人(译)	常识, LTD.		
[标]发明人	KRITZMAN AMNON NACHSHON NITSA G BEHAR YAEL		
发明人	KRITZMAN, AMNON NACHSHON, NITSA G. BEHAR, YAEL		
IPC分类号	C12M1/34 A61B5/00		
CPC分类号	A61B5/14539 A61F13/42 C12Q1/04 G01N33/528 G01N33/54366 A61B10/0048 A61B10/007 A61B2010/0074 A61F2013/427 A61F2013/8497 G01N31/221		
审查员(译)	吉特默, RALPH		
优先权	60/365684 2002-03-18 US		
其他公开文献	US20070003993A1		
外部链接	Espacenet USPTO		

摘要(译)

一种用于鉴定分泌的生物流体的分泌物监测物品。该制品包括具有吸收材料的主体，用于吸收人体分泌的生物流体和指示系统。指示剂系统包括指示剂和离子平衡试剂，其中指示剂系统提供与pH或生物流体的缓冲能力相关的生理条件的指示，该指示稳定至少48，优选至少72小时。该制品可以体现为拭子，纱布，护罩，卫生巾，尿布或阴唇间吸收结构，并且可以用于指示羊水或与细菌性阴道病相关的分泌物的存在，而不会在暴露于尿液时产生假阳性结果或干燥后。

Equation 1:

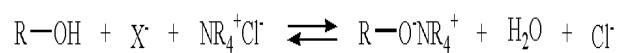

Equation 2:

