



US006821255B2

(12) **United States Patent**
Amano

(10) **Patent No.:** **US 6,821,255 B2**
(45) **Date of Patent:** **Nov. 23, 2004**

(54) **MERIDIAN POINT-PROBING DEVICE AND CURATIVE EFFECT-DETERMINING DEVICE**

5,730,138 A 3/1998 Wang
6,248,064 B1 6/2001 Gopinathan et al.
6,306,160 B1 * 10/2001 Nidetzky 607/89

(75) Inventor: **Kazuhiko Amano**, Yokohama (JP)

FOREIGN PATENT DOCUMENTS

(73) Assignee: **Seiko Epson Corporation**, Tokyo (JP)

DE	198 05 939 A1	8/1999	
DE	19805939	* 8/1999 600/500
DE	199 08 853 A1	9/2000	
DE	19908853	* 9/2000 600/481
EP	0689855	* 6/1994 607/1
WO	WO 97/24980	9/1997	

(*) Notice: Subject to any disclaimer, the term of this patent is extended or adjusted under 35 U.S.C. 154(b) by 0 days.

(21) Appl. No.: **10/224,370**

OTHER PUBLICATIONS

(22) Filed: **Aug. 21, 2002**

translation of German Patent 198 05 939.*

(65) **Prior Publication Data**

* cited by examiner

US 2003/0125631 A1 Jul. 3, 2003

(30) **Foreign Application Priority Data**

Primary Examiner—Robert L. Nasser
(74) *Attorney, Agent, or Firm*—Oliff & Berridge, PLC

Aug. 22, 2001 (JP) 2001-251876

(57) **ABSTRACT**

(51) **Int. Cl.**⁷ **A61B 5/00**

A meridian point-probing device includes a pulse wave-detecting unit for detecting pulse waves, a stimulation unit having an end that stimulates a position of skin of a trial subject, a memory unit for storing pulse waveforms detected by the pulse wave-detecting unit before and after the stimulation of the position by the stimulation unit, and a meridian point determination unit for determining whether the stimulation position is a meridian point, according to the pulse waveforms stored in the memory unit. The position of the meridian point can be objectively determined with high reproducibility.

(52) **U.S. Cl.** **600/500; 600/548**

(58) **Field of Search** **600/485-503, 600/548**

(56) **References Cited**

U.S. PATENT DOCUMENTS

3,207,151 A	*	9/1965	Takagi	600/547
4,160,447 A	*	7/1979	Teshima et al.	600/548
4,408,617 A	*	10/1983	Auguste	600/548
4,556,064 A		12/1985	Pomeranz et al.		
5,144,554 A		9/1992	Zhang et al.		

3 Claims, 9 Drawing Sheets

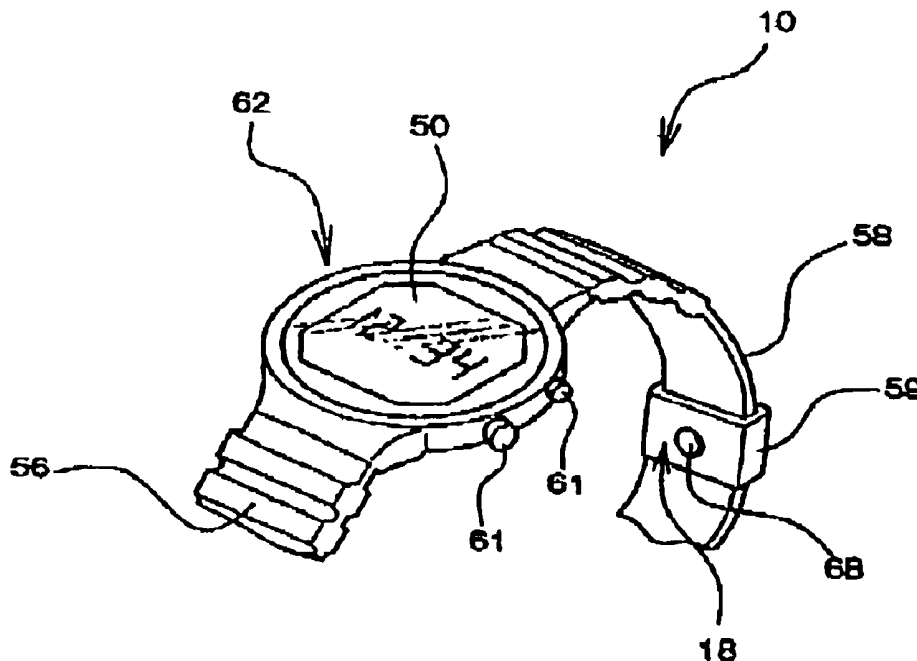

[FIG. 1]

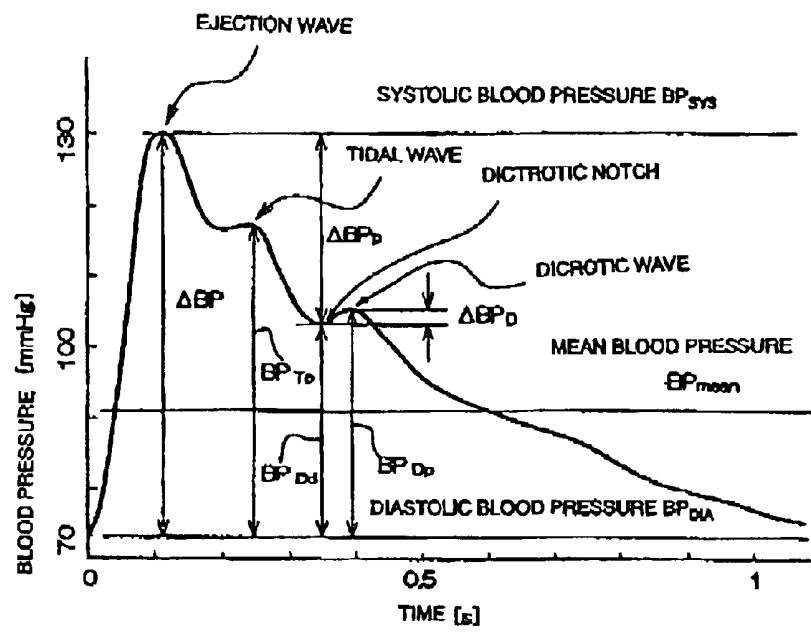

[FIG. 2]

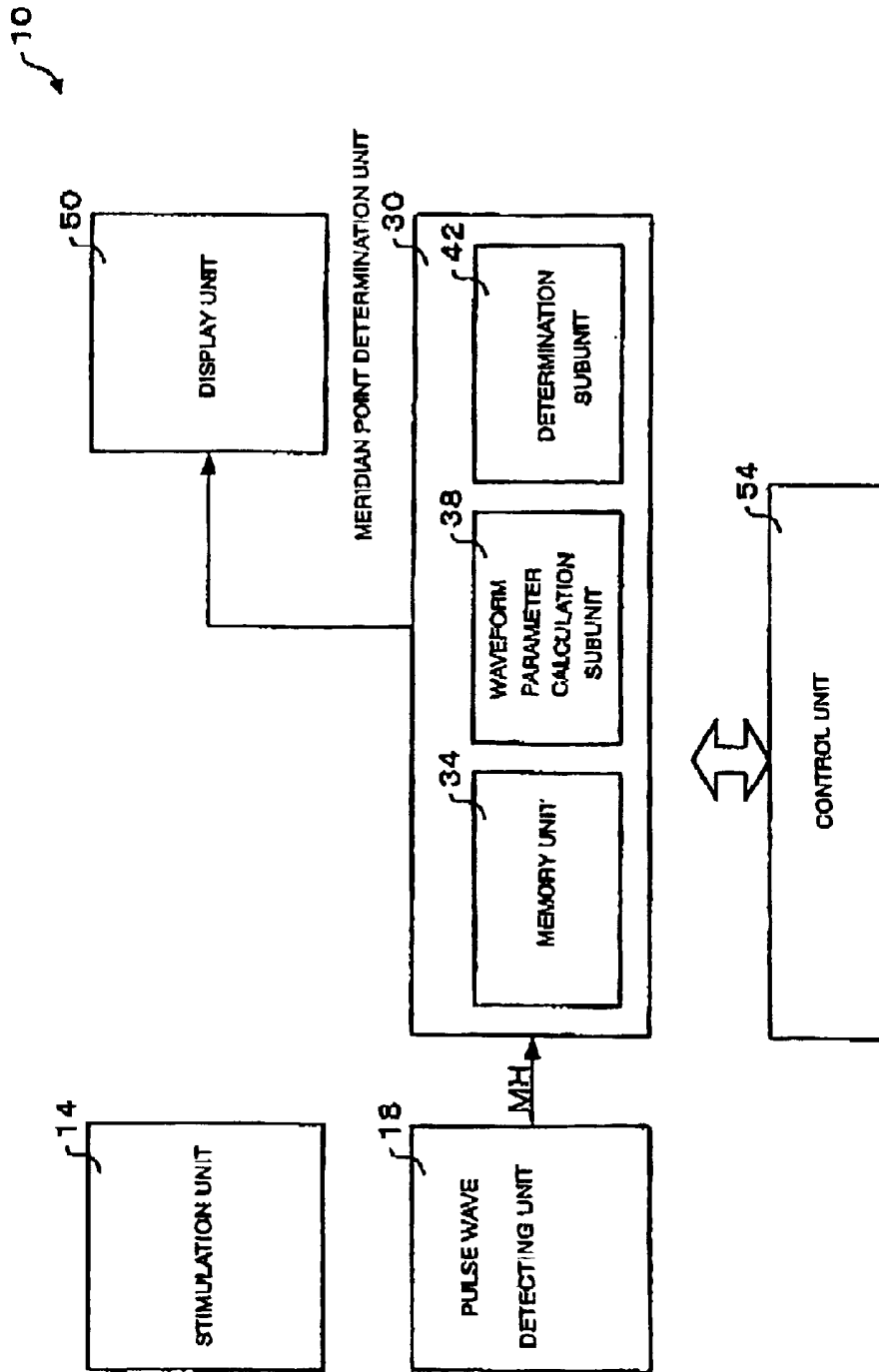

[FIG. 3]

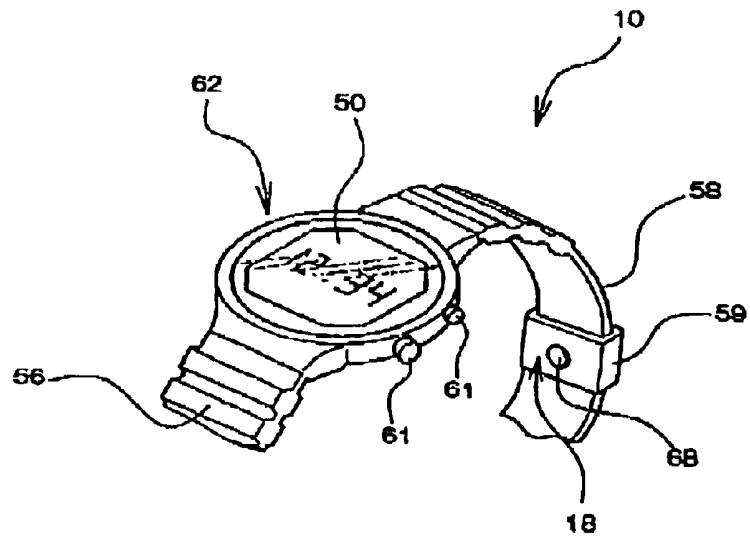

[FIG. 4]

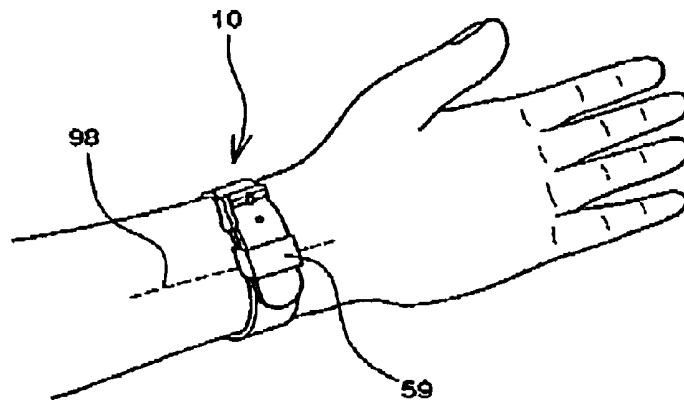

[FIG. 5]

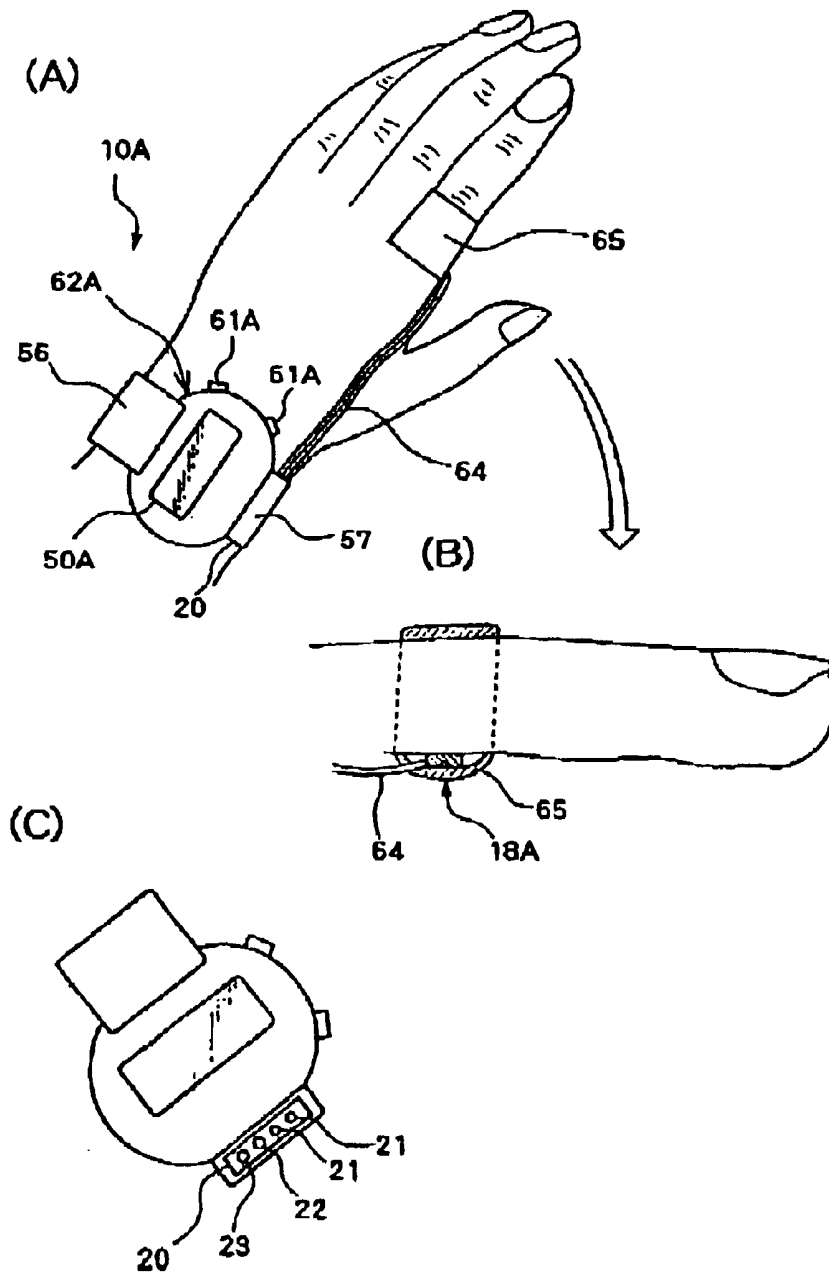

[FIG. 6]

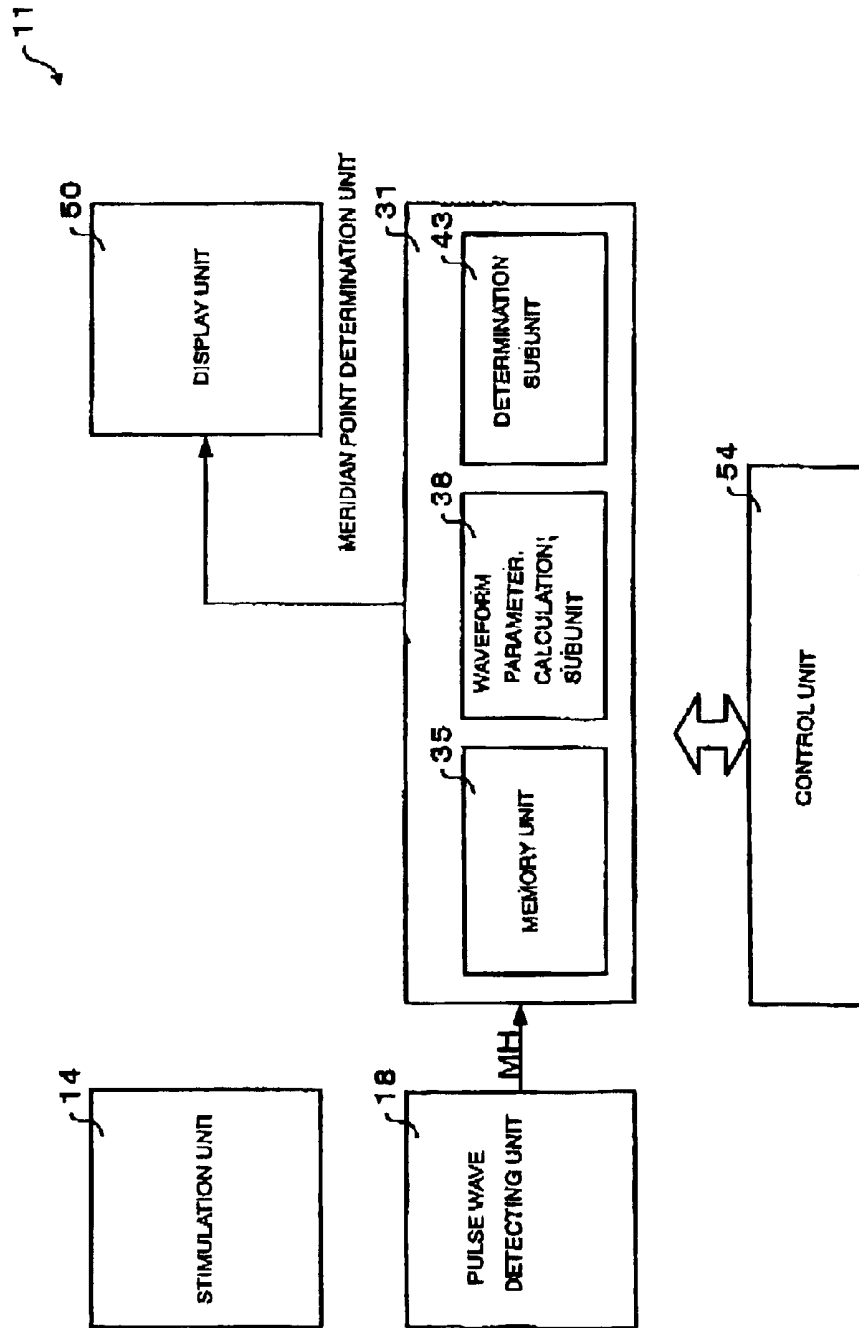
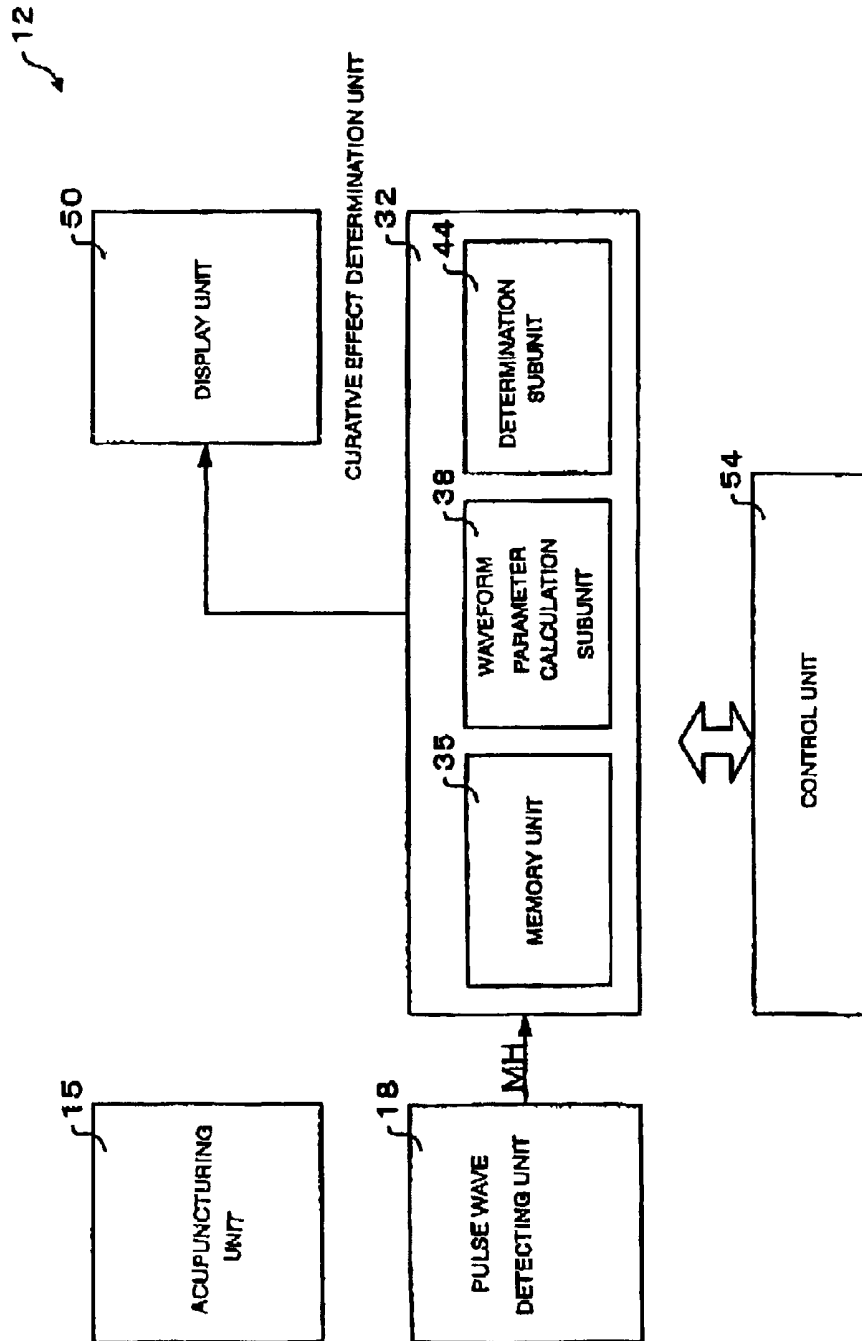
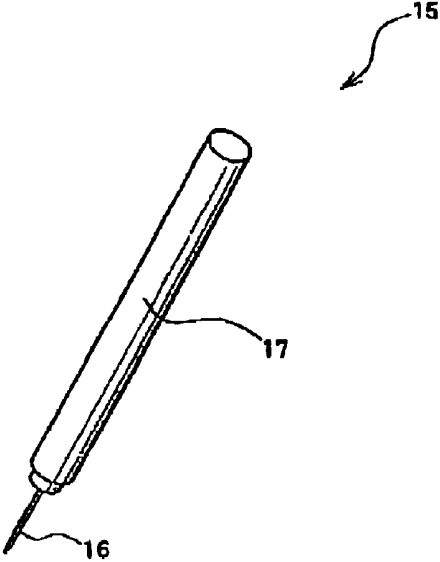

FIG. 7



[FIG. 8]



[FIG. 9]

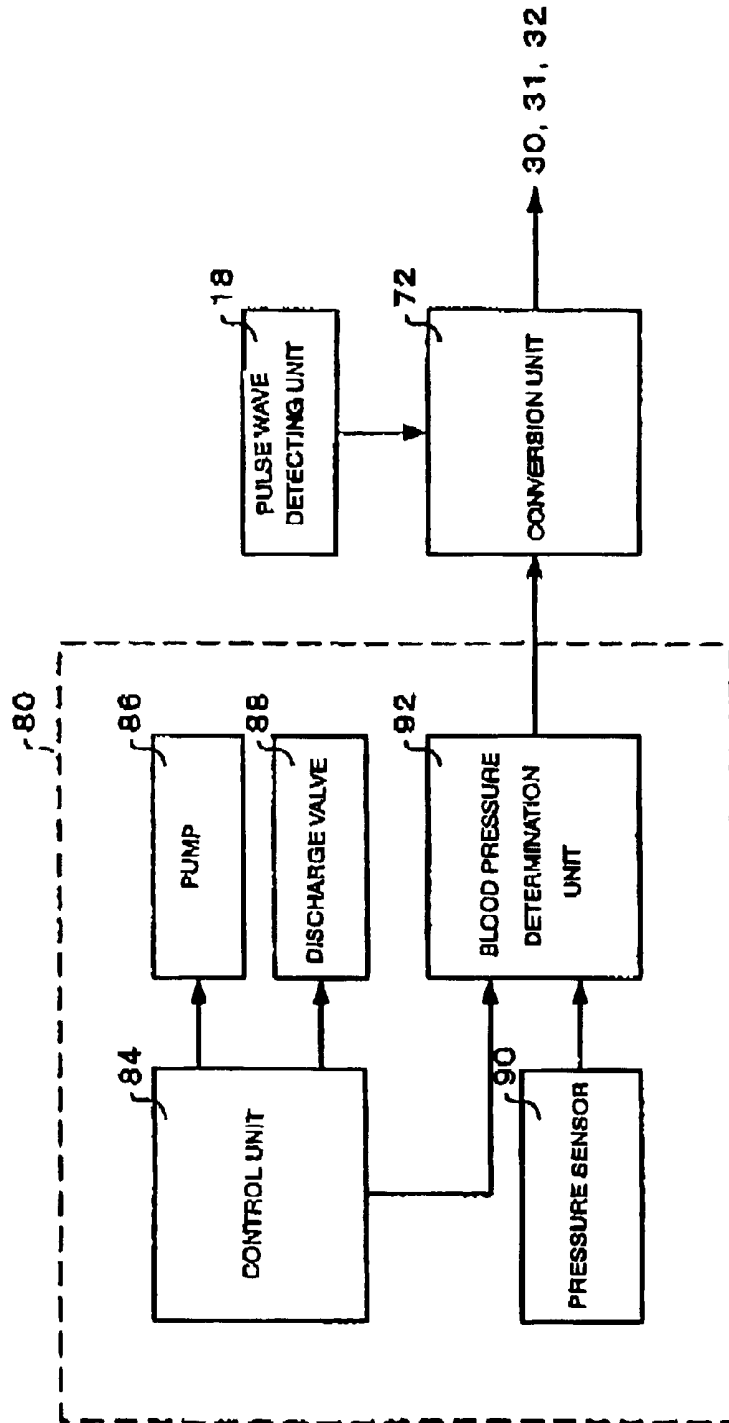

[FIG. 10]

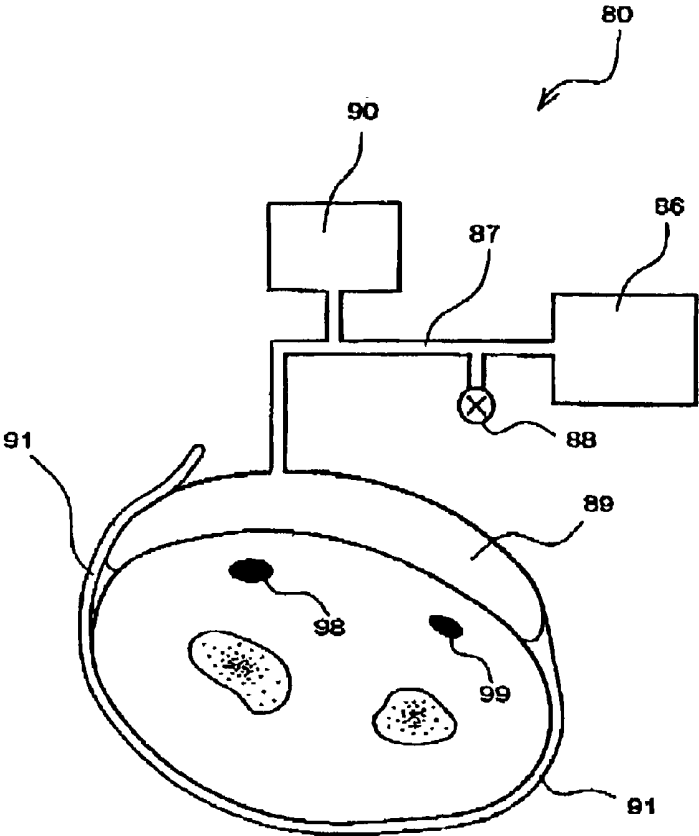

MERIDIAN POINT-PROBING DEVICE AND CURATIVE EFFECT-DETERMINING DEVICE

FIELD OF THE INVENTION

The present invention relates to a meridian point-probing device and a curative effect-determining device, which relate to meridian points ("tsubo" in Japanese) in oriental medicine.

DESCRIPTION OF RELATED ART

In acupuncture and moxibustion therapy, acupuncture and/or moxibustion is applied to spots called meridian points (tsubo) in oriental medicine for therapy. It is known that the curative effect largely depends on whether such therapy is performed at proper meridian points. Thus, it is important to determine proper meridian points in the acupuncture and moxibustion therapy.

However, in current acupuncture and moxibustion therapy, the meridian points are subjectively determined based on rough positions in a "keiraku" (energy system) diagram that is shown in many oriental medicine documents and by intuition and trial therapy according to clinical experiences. Accordingly, the meridian points have been determined subjectively without reproducibility.

The effects of the acupuncture and moxibustion therapy that targets the above-determined meridian points are also confirmed by a diagnostic process with an interview to a patient and pulse diagnosis called "myakushin" (sphygmopalpation) by an acupuncture and moxibustion therapist. Thus, the effects are also determined subjectively. In the pulse diagnosis, the therapist touches the radial artery of the patient to observe the pulse state.

A commercially available meridian point-probing device identifies a point having a lower contact resistance than that of its peripheries as a meridian point, but the results are unreliable.

SUMMARY OF THE INVENTION

An object of the present invention is to provide a meridian point-probing device and a curative effect-determining device having the following advantages:

- A. Capable of detecting meridian points objectively and reproducibly and
- B. Capable of determining the effects of the acupuncture and moxibustion therapy objectively.

(1) A meridian point-probing device according to the present invention includes a pulse wave-detecting unit which detects pulse waves, a stimulation unit having an end that stimulates a position of skin of a trial subject, a memory unit which stores pulse waveforms detected by the pulse wave-detecting unit before and after the stimulation of the position by the stimulation unit, and a meridian point determination unit which determines whether the stimulated position is a meridian point, according to the pulse waveforms stored in the memory unit.

According to the present invention, the pulse wave-detecting unit detects pulse waveforms before and after the stimulation unit stimulates a position, the memory unit stores the pulse waveforms, and the meridian point determination unit determines whether the position stimulated by the stimulation unit is a meridian point according to the pulse waveforms. The position of the meridian point can thereby be objectively determined with high reproducibility.

(2) A meridian point-probing device according to the present invention includes a pulse wave-detecting unit which detects pulse waves a stimulation unit having an end that stimulates skin of a trial subject, a memory unit which stores pulse waveforms detected by the pulse wave-detecting unit after the stimulation of a plurality of positions of the skin of the trial subject by the stimulation unit, and a meridian point determination unit which determines whether each of the stimulated positions is a meridian point, according to the pulse waveforms stored in the memory unit.

According to the present invention, the pulse wave detecting unit detects pulse waveforms after the stimulation unit stimulates a plurality of positions, the memory unit stores the pulse waveforms, and the meridian point determination unit determines whether each of the positions stimulated by the stimulation unit is a meridian point according to the corresponding pulse waveform. The positions of the meridian points can thereby be objectively determined with high reproducibility.

(3) The meridian point determination unit may include a waveform parameter calculation subunit that calculates a parameter on the pulse waveforms and determines whether the stimulated position is a meridian point, according to the parameter.

(4) The waveform parameter calculation subunit may calculate a pulse pressure that is a differential pressure between a systolic blood pressure and a diastolic blood pressure, a post-ejection pressure that is a differential pressure between a blood pressure at a dicrotic notch and the systolic blood pressure, a dicrotic wave height that is a differential pressure between the blood pressure at the dicrotic notch and a maximum blood pressure of the dicrotic wave, an post-ejection pressure ratio that corresponds to the post-ejection pressure normalized by the pulse pressure, a dicrotic wave height ratio that corresponds to the dicrotic wave height normalized by the pulse pressure, a tidal wave height ratio that corresponds to the tidal wave height normalized by the pulse pressure wherein the tidal, wave height is a differential pressure between the blood pressure of the post-ejection pressure and a maximum blood pressure of a tidal wave, or a pulse from the pulse waveforms stored in the memory unit.

(5) A curative effect-determining device according to the present invention includes a pulse wave-detecting unit which detects pulse waves, an acupuncture unit having an acuminate tip for performing an acupuncture treatment, a memory unit which stores pulse waveforms detected by the pulse wave-detecting unit before and after the acupuncturing treatment by the acuminate tip, and a curative effect determination unit which determines the curative effect of the acupuncturing treatment, according to the pulse waveforms stored in the memory unit.

According to the present invention, the pulse wave-detecting unit detects pulse waveforms before and after the acupuncturing treatment by the acupuncture unit, the memory unit stores the pulse waveforms, and the curative effect determination unit determines the effect of the acupuncturing treatment by the acupuncture unit according to the pulse waveforms stored in the soft magnetic assist film. The effect of the acupuncturing treatment can thereby be objectively determined.

(6) The curative effect determination unit may include a waveform parameter calculation subunit that calculates a parameter on the pulse waveforms and determines the curative effect of the acupuncturing treatment by the acuminate tip according to the parameter.

(7) The waveform parameter calculation subunit may calculate a pulse pressure that is a differential pressure

between a systolic blood pressure and a diastolic blood pressure a post-ejection pressure that is a differential pressure between a blood pressure at a dicrotic notch and the systolic blood pressure, a dicrotic wave height that is a differential pressure between the blood pressure at the dicrotic notch and a maximum blood pressure of the dicrotic wave, an post-ejection pressure ratio that corresponds to the post-ejection pressure normalized by the pulse pressure, a dicrotic wave height ratio that corresponds to the dicrotic wave height normalized by the pulse pressure, a tidal wave height ratio that corresponds to the tidal wave height normalized by the pulse pressure wherein the tidal wave height is a differential pressure between the blood pressure of the post-ejection pressure and a maximum blood pressure of a tidal wave, or a pulse from the pulse waveforms stored in the memory unit.

BRIEF DESCRIPTION OF THE DRAWINGS

FIG. 1 is a graph of a typical blood-pressure waveform in an artery;

FIG. 2 is a block diagram of a functional configuration of a meridian point-probing device according to Embodiment A

FIG. 3 is an outline view other than a stimulation unit of the meridian point-probing device according to Embodiment FIG. 4 is an isometric view of the meridian point-probing device shown in FIG. 3 that is worn on a wrist;

FIGS. 5(A), 5(B), and 5(C) are outline views other than a stimulation unit of a meridian point-probing device according to a modification;

FIG. 6 is a block diagram of a functional configuration of a meridian point-probing device according to Embodiment B;

FIG. 7 is a block diagram of a functional configuration of a meridian point-probing device according to Embodiment C;

FIG. 8 is an isometric view of an exemplary acuminate tip;

FIG. 9 is a block diagram of a functional configuration and an additional part of a blood pressure measuring unit and

FIG. 10 is a schematic view illustrating a measurement of blood pressure by the blood pressure measuring unit.

DESCRIPTION OF THE PREFERRED EMBODIMENTS

Preferred embodiments of the present invention will now be described in further detail with reference to the drawings.

1. Fundamental Principle

FIG. 1 is a graph of a typical blood-pressure waveform in an artery, for example, a radial artery. As shown in this drawing, a blood pressure waveform in the artery has an ejection wave having the highest peak, a tidal wave having the second highest peak, and a dicrotic wave having the third highest peak. The minimum point or inflection point between the tidal wave and the dicrotic wave is called a dicrotic notch. The peak of the ejection wave corresponds to the systolic blood pressure (maximum pressure) BP_{sys} in the waveform. The diastolic blood pressure BP_{dia} corresponds to the minimum blood pressure in the waveform. A differential pressure between the systolic blood pressure BP_{sys} and the diastolic blood pressure BP_{dia} is called a pulse pressure ΔBP . The mean blood pressure BP_{mean} is obtained by time-averaging the integral value of the blood pressure waveform.

In this specification, a differential pressure between the systolic blood pressure ΔBP_{sys} and the blood pressure at the

dicrotic notch is called a post-ejection pressure ΔBP_p ; a differential pressure between the blood pressure at the dicrotic notch and the maximum blood pressure of the dicrotic wave is called a dicrotic wave height ΔBP_D ; and the differential pressure between the diastolic blood pressure BP_{dia} and the maximum blood pressure of the tidal wave is called a tidal wave height ΔBP_{TP} .

Meanwhile nifedipine, a calcium antagonist having vasodilatation, is known to have a pharmacological action that temporarily improves distensibility of blood vessel. This action is similar to a physiological state in which parasympathetic nerve dominantly works as a result of suppression of the activity of sympathetic nerve.

The present inventors measured the post-ejection pressures ΔBP_p (mmHg) of a plurality of trial subjects before and after nifedipine was administrated. Table 1 shows the results, wherein the post-ejection pressure ΔBP_p (mmHg) before administration was obtained by arithmetic average of pulse waveforms of the radial artery one hour before administration, and the post-ejection pressure ΔBP_p (mmHg) after administration was obtained by arithmetic average of pulse waveforms of the radial artery one hour after administration.

FIG. 1(A) shows that trial subjects A and B had no significant difference in the post-ejection pressure ΔBP_p between before and after nifedipine administration, but other four trial subjects C to F had an obvious increase in the post-ejection pressure ΔBP_p between before and after nifedipine administration. Accordingly, the post-ejection pressure ΔBP_p , one parameter obtained from the radial artery pulse waveforms, is distinctly dependent on the physiological state.

Accordingly, monitoring the change in one parameter such as the post-ejection pressure ΔBP_p obtained from the radial artery pulse waveforms enables detection of a change in physiological states of trial subjects.

2. Embodiment A

2.1 Functional Configuration of Meridian Point-probing Device

FIG. 2 is a block diagram of a functional configuration of a meridian point-probing device 10 according to this embodiment. As shown in the drawing, the meridian point-probing device 10 includes a stimulation unit 14, a pulse wave-detecting unit 18, a meridian point determination unit 30, a display unit 50, and a control unit 54.

The stimulation unit 14 has an end that stimulates skin of a human body.

The pulse wave-detecting unit 18, for example, has a pressure sensor and detects pulse waves generated by progressive expansion of an artery that follows left ventricular systole.

The meridian point determination unit 30 determines whether a position stimulated by the stimulation unit 14 is a meridian point according to the pulse waveforms detected by the pulse wave-detecting unit 18. For example, the meridian point determination unit 30 includes a memory unit 34, a waveform parameter calculation subunit 38, and a determination subunit 42. In other words, the meridian point determination unit 30 includes a CPU and a memory storing programs for operating the CPU.

The memory unit 34 stores the pulse waveforms detected by the pulse wave-detecting unit 18 before and after the stimulation unit 14 stimulates a position. The memory unit 34 may be any recording medium, for example, a semiconductor memory, a magnetic recording medium, or an optical recording medium.

The waveform parameter calculation subunit 38 calculates a pulse waveform parameter such as the post-ejection pressure ΔBP_p from the pulse waveforms stored in memory unit 34.

The determination subunit **42** determines whether the position stimulated by the stimulation unit **14** is a meridian point according to a parameter such as the post-ejection pressure ΔBP_p before and after the stimulation unit **14** stimulates the position.

The display unit so displays the determined results on the stimulated position by the meridian point determination unit **30** in the form of text, symbol, or graph.

2.2 Outline Configuration of Meridian Point-probing Device

For example, the meridian point-probing device **10** excluding the stimulation unit **14** may be used in the form of a wristwatch, as shown in FIGS. **3** and **4**. FIG. **3** is an isometric view of the device itself, and FIG. **4** is an isometric view of the device that is worn on a wrist.

As shown in these drawings, the meridian point-probing device **10**, excluding the stimulation unit **14**, includes a main portion **62**, a pair of bands **56** and **58** attached to the main portion **62**, a sensor holder **59** movable along the band **58**. The sensor holder **59** includes a pulse wave-detecting unit **18** having a protruding pressure sensor **68**. The protruding pressure sensor **68** transmits signals to the main portion **62** through a connection not shown in the drawing, for example, a flexible printed circuit (PPC) board.

The main portion **62** includes at least one semiconductor integrated circuit (IC) now shown in the drawing. In this embodiment, the display unit **50** displays time information. Operating knobs **61** switches between a measuring mode for measuring pulse waveforms and a watch mode for displaying time. The operating knobs **61** are also used for inputting various data.

When the meridian point-probing device **10** is used, as shown in FIG. **4**, the meridian point-probing device **10** is worn on a wrist of a trial subject like a wristwatch such that the sensor holder **59** lies near the radial artery **98**. The sensor holder **59** is slid along the band **58** so that the pressure sensor **68** of the sensor holder **59** is disposed on the radial artery **98**.

When the pressure sensor **68** presses the radial artery **98** of the trial subject, pulse waves corresponding to vibrations of the vessel wall caused by a change in blood flow in the artery are transmitted from the pressure sensor **68** to the pulse wave-detecting unit **18**. The meridian point-probing device **10** can thereby detect pulse waveforms. The detected pulse waveforms are substantially the same as blood pressure waveforms of the artery.

2.3 Operation of Meridian Point-probing Device

The meridian point-probing device **10** determines whether a position of a trial subject stimulated by the stimulation unit is a meridian point, according to the following operation.

The band **58** is wound around the wrist and the sensor holder **59** is fixed near the radial artery **98**.

Before the stimulation unit **14** stimulates a position of the trial subject, the pressure sensor **68** of the pulse wave-detecting unit **18** detects the pulse waveform (vibration waveform of the vessel wall that follows a blood flow in an artery of the wrist such as the radial artery **98**) as a pressure waveform. The pulse waveform detected by the pressure sensor **68** is stored in the memory unit **34**. The waveform parameter calculation subunit **38** calculates a parameter according to the pulse waveform stored in the memory unit **34**.

A portion presumed to be a meridian point is stimulated by the stimulation unit **14**.

After the stimulation to the trial subject by the stimulation unit **14**, the pressure sensor **68** redetects a pulse waveform. The pulse waveform detected by the pressure sensor **68** is stored in the memory unit **34**. According to the pulse

waveform stored in the memory unit **34**, the waveform parameter calculation subunit **38** calculates a parameter of the pulse waveform such as the post-ejection pressure ΔBP_p .

The determination subunit **42** determines whether the position stimulated by the stimulation unit **14** is a meridian point according to the parameter, for example, the post-ejection pressures ΔBP_p calculated by the waveform parameter calculation subunit **38** before and after the stimulation by the stimulation unit **14**.

The results appear on the display unit **50**, for example, including a liquid crystal display, in the form of text and graph.

2.4 Modifications of Embodiment A

2.4.1 In the above embodiment, the parameter, which is calculated by the waveform parameter calculation subunit **38** of the meridian point determination unit **30** and is used for determining whether the stimulated position is a meridian point in the determination subunit **42**, is the post-ejection pressure ΔBP_p . Alternatively, the parameter which is calculated in the waveform parameter calculation subunit **38** of the meridian point determination unit **30** and is used for determination in the determination subunit **42**, may be the pulse pressure ΔBP , which is a differential pressure between the systolic blood pressure and the diastolic blood pressure; the dicrotic wave height ΔBP_p , which is a differential pressure between the blood pressure at the dicrotic notch and the maximum blood pressure of the dicrotic wave; a post-ejection pressure ratio $\Delta BP_p/\Delta BP$, which corresponds to the post-ejection pressure (–a differential pressure between the systolic blood pressure and the blood pressure at the dicrotic notch) normalized by the pulse pressure; a dicrotic wave height ratio $\Delta BP_p/\Delta BP$, which corresponds to the dicrotic wave height (–a differential pressure between the blood pressure at the dicrotic notch and the maximum blood pressure of the dicrotic wave) normalized by the pulse pressure; a tidal wave height ratio $\Delta BP_{tp}/\Delta BP$, which corresponds to the tidal wave height (–a differential pressure between the diastolic blood pressure ΔBP_{dia} and the maximum blood pressure of the tidal wave) normalized by the pulse pressure; or a pulse.

2.4.2 In the above embodiment, the pulse wave-detecting unit detects pulse waveforms of the radial artery **98**. Alternatively, the pulse wave-detecting unit may detect pulse waveforms of any appendicular or finger arteries, such as an ulnar artery of a wrist, a palmar digital artery of a finger, a brachial artery of an upper arm, or a popliteal artery of a lower limb. Alternatively, the pulse wave-detecting unit may detect pulse waveforms of any other arteries flowing near the surface, such as carotid artery and femoral artery.

2.4.3 In the above embodiment, the pulse wave-detecting unit is a pressure sensor. Since the pulse waveform is substantially the same as a change waveform of a blood flow rate, the pulse wave-detecting unit may be an optical sensor that emits light toward an artery and detects a change in reflected light intensity or transmitted light caused by the blood flow in the artery, in place of the pressure sensor.

For example, such an optical sensor is composed of a light-emitting diode (LED) and a phototransistor. The wavelength of light emerging from the LED is set near the peak wavelength of reflection or absorption of hemoglobin in the blood while the wavelength range of light received by the phototransistor is set near the peak wavelength of reflection or absorption of the hemoglobin. Thus, the received light intensity changes with the blood flow rate. The pulse waveform can thereby be detected as a change in the received light intensity.

Such an optical sensor detects pulse waves that change in response to the blood flow rate, namely, volume pulse waves

as a change in the red blood count in the capillary plexus near skin and thus as a change in transmittance or reflectance of light emerging toward the skin. Thus, the optical sensor can detect pulse waves without aligning the sensor to, for example, a radial artery. Thus, the pulse wave-detecting unit including such an optical sensor can stably detect a change in the red blood count in the capillary plexus near skin as pulse waves (volume pulse waves) in a peripheral artery.

As described above, the meridian point-probing device **10** according to the present invention can use the post-ejection pressure ratio $\Delta BP_p/\Delta BP$, which corresponds to the post-ejection pressure (—a differential pressure between the maximum blood pressure and the blood pressure at the dicrotic notch) normalized by the pulse pressure (—a differential pressure between the maximum pressure and the minimum pressure), the dicrotic wave height ratio $\Delta BP_d/\Delta BP$, which corresponds to the dicrotic wave height (—a differential pressure between the blood pressure at the dicrotic notch and the maximum blood pressure of the dicrotic wave) normalized by the pulse pressure, the tidal wave height ratio $\Delta BP_T/\Delta BP$ which corresponds to the tidal wave height normalized by the pulse pressure, or the pulse, as a parameter used for determining whether the position stimulated by the stimulation unit **14** is a meridian point. Thus, the pulse wave-detecting unit does not need to detect the blood pressure itself directly. Accordingly, a pulse wave-detecting unit including a photoelectric sensor capable of detecting a waveform that is substantially the same as the waveform of the blood pressure can be used in the above meridian point-probing device.

FIGS. 5(A), 5(B), and 5(C) are outline views of a meridian point-probing device **10A** including such a pulse wave-detecting unit **18A** (not including the stimulation unit **14**). The meridian point-probing device **10A** includes a main portion **62A** having a structure like a wrist watch, a cable **64** connected to a connector **20** of the main portion **62A** with a connector piece **57**, and the pulse wave-detecting unit **18A** provided at an end of the cable **64**. The main portion **62A** has a wristband **56** for fixing the main portion **62A** to a wrist of a trial subject.

The main portion **62A** includes the connector **20**. The detachable connector piece **57** at the other end of the cable **64** is connected to the connector **20**.

FIG. 5(C) shows the connector **20** from which the connector piece **57** is detached. For example, the connector **20** includes connection pins **21** for connecting to the cable **64**, an LED **22** for transmitting data, and a phototransistor **23**.

At the surface of the main portion **62A**, a display unit **50A** composed of a liquid crystal panel is provided. The display unit **50A** has a segment display region and a dot display region and displays a central blood pressure waveform, a central blood pressure waveform parameter, or analytical results, for example. The display unit **50A** may be any other display devices in place of the liquid crystal panel.

The main portion **62A** includes a central processing unit (CPU) for controlling various calculations and conversions and a memory (not shown) for storing programs for CPU operation in the interior and includes operation knobs **61A** for various operations and inputting at the periphery.

As shown in FIG. 5(B) the pulse wave-detecting unit **18A** is shaded by a band **65** for fixing the sensor and is fixed near the bottom of the index finger of a trial subject. Since the pulse wave-detecting unit **18A** is fixed in such a manner, a abort cable **64** can be used and is not a hindrance of fixing. Since a change in blood flow rate with temperature at the bottom of a finger is smaller than that at the fingertip, the detected pulse waveform is not so affected by the environmental temperature.

2.4.4 In the above embodiment, the meridian point determination unit **30**, the display unit **50**, and the control unit **54** are built into the main portion **62**. Any one of these units may be separated from the main portion **62** and may be electrically connected to the pulse wave-detecting unit **18** or the stimulation unit **14**.

2.4.5 In the above embodiment, the display unit **50** including the liquid crystal display is used as a disclosure portion, and the display unit **50** display a text and graph. Alternatively, a printer, a voice synthetic unit, or a speaker may be used as a disclosure portion instead of or together with the display unit **50** to display the information as display, printed text, or voice.

2.5 Effects of Embodiment A

As described above, in the meridian point-probing device **10** according to this embodiment, the pulse wave-detecting unit **18** detects pulse waveforms before and after the stimulation unit **14** stimulates a position, the memory unit **34** stores the pulse waveforms, and the meridian point determination unit **30** determines whether the position stimulated by the stimulation unit **14** is a meridian point according to the pulse waveforms. The position of the meridian point can thereby be objectively determined with high reproducibility.

3. Embodiment B

The meridian point-probing device in this embodiment differs from that according to Embodiment A in that the memory unit stores pulse waveforms detected by the pulse wave-detecting unit after the stimulation of a plurality of positions by the stimulation unit and the meridian point determination unit determines whether each of the stimulated positions is a meridian point, according to the pulse waveforms stored in the memory unit. The differences from Embodiment A will now be intensively described. Since other features are the same as those in Embodiment A, the description thereof is omitted. The same reference numerals are allocated to the same components in the drawings

3.1 Functional Configuration of Meridian Point-probing Device

FIG. 6 is a block diagram of a functional configuration of a meridian point-probing device **11** according to this embodiment. The functional configuration of this embodiment is substantially the same as that in Embodiment A.

The operation of the meridian point determination unit, however, is partly different.

In this embodiment, the meridian point determination unit **31** stores pulse waveforms that are detected by the pulse wave-detecting unit **18** after the stimulation of a plurality of positions by the stimulation unit. The meridian point determination unit **31** includes a memory unit **35**, a waveform parameter calculation subunit **38**, and a determination Subunit **43**.

The memory unit **35** stores the pulse waveforms a plurality of positions detected by the pulse wave-detecting unit **18** after the stimulation unit **14** stimulates these positions.

The waveform parameter calculation subunit **38** calculates a pulse waveform parameter such as a post-ejection pressure ΔBP_p from each of the pulse waveforms stored in the memory unit **35**.

The determination subunit **43** determines whether each of the positions stimulated by the stimulation unit **14** is a meridian point according to a parameter corresponding to each position. For example, the determination subunit **43** compares post-ejection pressures ΔBP_p that are calculated in the waveform parameter calculation subunit **38** to determine whether each of the positions simulated by the stimulation unit **14** it a meridian point.

3.2 Outline Configuration of Meridian Point-probing Device

The outline configuration of the meridian point-probing device **10** according to this embodiment may be the same as that in Embodiment A.

3.3 Operation of Meridian Point-probing Device

The meridian point-probing device **11** determines whether each of the positions of a trial subject stimulated by the stimulation unit **14** is a meridian point, according to the following operation.

The band **59** is wound around the wrist and the sensor holder **59** is fixed near the radial artery **98**.

A portion presumed to be a meridian point is stimulated by the stimulation unit **14**.

After a predetermined time from the stimulation to the trial subject by the stimulation unit **14**, the pressure sensor **68** redetects a pulse waveform. The pulse waveform detected by the pressure sensor **68** is stored in the memory unit **34**.

The stimulation by the stimulation unit **14** and detecting and storing of the pulse waveform after the predetermined time from the stimulation are repeated for a plurality of positions.

According to the pulse waveform corresponding to each stimulated position stored in the memory unit **34**, the waveform parameter calculation subunit **38** calculates a parameter of the pulse waveform such as the post-ejection pressure ΔBP_p . Next, the determination subunit **43** compares the parameters corresponding to the stimulated positions to determine whether each of the stimulated positions is meridian point.

The determined results appear on the display unit **50**, which for example, includes a liquid crystal display device, in the form of text, symbol, or graph.

3.4 Modifications of Embodiment B

3.4.1 In the above embodiment, the memory unit stores pulse waveforms corresponding to the stimulated positions and the waveform parameter calculation subunit calculates the parameters after these pulse waveforms are stored. Alternatively, the waveform parameter calculation subunit may calculate each parameter after a pulse waveform corresponding to each of the stimulated positions is stored.

3.4.2 Each modification shown in Embodiment A may also be applied to this Embodiment.

3.5 Effects of Embodiment B

As described above, the pulse wave-detecting unit **18** detects pulse waveforms after the stimulation unit **14** stimulates a plurality of positions, the memory unit **35** stores the pulse waveforms, and the meridian point determination unit **31** determines whether each of the positions stimulated by the stimulation unit **14** is a meridian point according to the corresponding pulse waveform. The positions of the meridian points can thereby be objectively determined with high reproducibility.

4. Embodiment C

A curative effect-determining device according to this embodiment fundamentally differs from the meridian point-probing device according to Embodiment A in that the stimulation unit is replaced with an acupuncture unit and the meridian point determination unit is replaced with a curative effect determination unit. The differences from Embodiment A will now be intensively described. Since other features are the same as those in Embodiment A, the description thereof is omitted. The same reference numerals are allocated to the same components in the drawings.

4.1 Functional Configuration of Curative Effect-Determining Device

FIG. 7 is a block diagram of a functional configuration of a curative effect-determining device **12** according to this

embodiment. The functional configuration of this embodiment is substantially the same as that in Embodiment A. However, the stimulation unit **14** is replaced with an acupuncture unit **15** and the meridian point determination unit **30** is replaced with a curative effect determination unit **32**.

The acupuncture unit **15** has an acuminate tip used for performing an acupuncture treatment.

The curative effect determination unit **32** determines the curative effect of the acupuncture treatment, according to the pulse waveforms detected by the pulse wave-detecting unit **18** before and after the acupuncture treatment. For example, the curative effect determination unit **32** includes a memory unit **36**, a waveform parameter calculation subunit **38**, and a determination subunit **44**. In other words, the curative effect determination unit **32** includes a CPU and a memory storing programs for operating the CPU.

The memory unit **36** stores the pulse waveforms detected by the pulse wave-detecting unit **18** before and after the acupuncture treatment by the acupuncture unit **15**. The memory unit **36** may be any recording medium, for example, a semiconductor memory, a magnetic recording medium, or an optical recording medium.

The waveform parameter calculation subunit **38** calculates a pulse waveform parameter such as the post-ejection pressure ΔBP_p from the pulse waveforms stored in the memory unit **36**.

The determination subunit **44** determines the curative effect of the acupuncture treatment according to the pulse waveforms detected by the pulse wave-detecting unit **18** before and after the acupuncture treatment by the acupuncture unit **15**. For example, the determination subunit **44** determines the curative effect according to a change in post-ejection pressure ΔBP_p before and after the acupuncture treatment, wherein the post-ejection pressure is one of the parameters calculated from the pulse waveforms.

The display unit **50** displays the determined results on the curative effect of the acupuncture treatment by the acupuncture unit **15** in the form of text, symbol, or graph.

4.2 Outline Configuration of Curative Effect-Determining Device

The outline configuration of the curative effect-determining device **12** is substantially the same as that in Embodiment A except that the acupuncture unit **15** is included.

FIG. 8 shows a schematic example of the acupuncture unit **15**. The acupuncture unit **15** includes an acuminate tip **16** and a holder **17** for holding the acuminate tip **16**.

4.3 Operation of Curative Effect-Determining Device

The curative effect-determining device **12** determines the curative effect of the acuminate tip according to the following operation.

The band **58** is wound around the wrist and the sensor holder **59** is fixed near the radial artery **98**.

Before the acupuncture treatment by the acupuncture unit **15**, the pressure sensor **68** of the pulse wave-detecting unit **18** detects the pulse waveform. The pulse waveform detected by the pressure sensor **68** is stored in the memory unit **36**. The waveform parameter calculation subunit **38** calculates a parameter, for example, a post-ejection pressure ΔBP_p , according to the pulse waveform stored in the memory unit **36**.

Next, the acupuncture unit **15** stimulates a portion of a trial subject according to the medical treatment.

After the stimulation of the position by the acupuncture unit **15**, the pressure sensor **68** redetects the pulse waveform. The memory unit **36** stores the pulse waveform detected by the pressure sensor **68**. The waveform parameter calculation

subunit **38** calculates a parameter of the pulse waveform according to the pulse waveform stored in the memory unit **36**.

Next, the determination subunit **44** determines the effect of the acupuncture treatment by the acupuncture unit **15** according to the parameters before and after the stimulation by the acupuncture unit **15**.

The results appear on the display unit **50**, for example, including a liquid crystal display, in the form of text and graph.

4.4 Modifications of Embodiment C

4.4.1 In the above embodiment, the parameter, which is calculated by the waveform parameter calculation subunit **38** of the curative effect determination unit **32** and is used for determining the curative effect by the determination subunit **44**, is the post-ejection pressure ΔBP_p . Alternatively, the parameter, which is calculated in the waveform parameter calculation subunit **38** of the curative effect determination unit **32** and is used for determination in the determination subunit **44**, may be the pulse pressure ΔBP , which is a differential pressure between the systolic blood pressure and the diastolic blood pressure; the dicrotic wave height ΔBP_p , which is a differential pressure between the blood pressure at the dicrotic notch and the maximum blood pressure of the dicrotic wave: a post-ejection pressure ratio $\Delta BP_p/\Delta BP$, which corresponds to the post-ejection pressure (–a differential pressure between the systolic blood pressure and the blood pressure at the dicrotic notch) normalized by the pulse pressure; a dicrotic wave height ratio $\Delta BP_p/\Delta BP$, which corresponds to the dicrotic wave height (–a differential pressure between the blood pressure at the dicrotic notch and the maximum blood pressure of the dicrotic wave) normalized by the pulse pressure; a tidal wave height ratio $\Delta BP_{Tp}/\Delta BP$, which corresponds to the tidal wave height (–a differential pressure between the diastolic blood pressure ΔBP_{dia} and the maximum blood pressure of the tidal wave) normalized by the pulse pressure; or a pulse.

4.4.2 Modifications 2.4.2, 2.4.3, 2.4.4, and 2.4.5 in Embodiment A can also be applied to this embodiment.

4.5 Effects of Embodiment C.

As described above, in the curative effect-determining device **12** according to this embodiment, the pulse wave-detecting unit **18** detects pulse waveforms before and after the acupuncture treatment by the acupuncture unit **15**, the memory unit **36** stores the pulse waveforms, and the curative effect determination unit **32** determines the effect of the acupuncture treatment by the acupuncture unit **15** according to the pulse waveforms stored in the soft magnetic assist film **36**. The effect of the acupuncture treatment can thereby be objectively determined.

5. Embodiment D

In the above embodiments, the probing of the meridian points and the determination of the curative effect are performed using pulse waveforms detected by the pulse wave-detecting unit **18** or **18A**. Alternatively, a blood pressure measuring unit and a conversion unit may be included together with the pulse wave-detecting unit so that the pulse waveforms are converted into blood pressure waveforms that are used for probing the meridian points or determining the curative effect.

FIG. **9** is a block diagram showing a functional configuration of the blood pressure measuring unit **80** and a portion relating to the blood pressure measuring unit **80**, namely, the relationship between the pulse wave-detecting in addition to the pulse wave-detecting units **18** and **18A** shown in the above embodiments any other pulse wave-detecting units having sensors for detecting pulse waveforms may be used.

The blood pressure measuring unit **80** measures the blood pressure at the same positions that are used for detecting pulse waves by the pulse wave-detecting unit **18**. An embodiment of the blood pressure measuring unit **80** will be described below in detail.

The **72** converts the pulse waveform detected by the pulse wave-detecting unit **18** into a blood pressure waveform at the position, according to the blood pressure value measured by the blood pressure measuring unit **80**. For example, the conversion unit **72** converts the pulse waveform into the blood pressure waveform using the amplitude between the systolic blood pressure and the diastolic blood pressure that are measured by the blood pressure measuring unit **80**. The resulting blood pressure waveform is input into the meridian point determination unit **30** or **31** or the curative effect determination unit **32** to perform determination using the blood pressure waveform instead of the pulse waveform.

FIG. **10** is a schematic view of the blood pressure measuring unit **80** for measuring the blood pressure. The blood pressure measuring unit **80** measures a blood pressure by winding a band **91** around a position for detecting the pulse wave by the pulse wave-detecting unit **18**, for example, a wrist. The band **91** has a pressure bag **89** therein and is wound around the wrist such that the pressure bag **89** faces the radial artery **98**.

The pressure bag **89** connects with a pump **86** and a discharge valve **88** via a pipe **87**. The pump **86** and the discharge valve **88** control the volume of a liquid charged in the pressure bag **89** to control the pressuring force of the pressure bag **89** to the radial artery **98**.

The pipe **87** is provided with a pressure sensor **90** for detecting the change in liquid pressure. The pressure sensor **90** detects vibration of the radial artery **98** as a change in pressure of the liquid that transmitted via the pressure bag **89** and the pipe **87**. Since the pressure bag **89** lying above the radial artery **98** is pressured in response to the vibration of the radial artery **98**, the pressure of the liquid in the pressure bag **89** changes in response to the vibration of the radial artery **98**. Thus, the pressure sensor **90** detecting such a change in pressure can output signals corresponding to the vibration of the radial artery **98**.

The blood pressure measuring unit **80**, constituting a part of the configuration shown in FIG. **9**, further includes a control unit **84** and a blood pressure determination unit **92**, in addition to the above units.

The control unit **84** controls the operation of the pump **86** and the discharge valve **88** to cause a change in pressure of the pressure bag **89** by controlling the volume of the liquid in the pressure bag **89** so that the pressure bag **89** presses the radial artery **98** with a variable applying pressure within a predetermined range. For example, the control unit **84** includes a CPU and a memory such a semiconductor memory for storing programs for CPU operation.

The blood pressure determination unit **92** inputs a variety of pressure information from the pressure bag **89** through the control unit **84** and detection signals from the pressure sensor **90** at each pressure and determines the maximum blood pressure and the minimum blood pressure according to the input information. For example, the blood pressure determination unit **92** includes a CPU and a memory for storing programs for CPU operation.

The operation of blood pressure measurement of the blood pressure measuring unit **80** will now be described.

The cuff band **91** is wound around a wrist such that the pressure bag **89** lies above the radial artery **98**.

The pump **86** and the discharge valve **88** are controlled by the control unit **84** to control the volume of the liquid in the

pressure bag 89. The applying pressure in the pressure bag 89 is thereby changed. The pressure bag 89 presses the radial artery at a variable applying pressure within a predetermined range. Specifically, the control unit 84 controls the applying pressure of the pressure bag 89 within the range of, for example, 250 to 20 mg, the range being slightly wider than a typical blood pressure range.

The pressure sensor 90 for detecting the vibration of the radial artery 98 detects signals corresponding to the vibration of the vascular wall due to blood flow in the blood vessel which is narrowed by each applying pressure from the pressure bag 89. The results are stored in the blood pressure determination unit 92 together with the corresponding applying pressure from the pressure bag 89. The applying pressure from the pressure bag 89 is transmitted from the control unit 84 for controlling the applying pressure to the blood pressure determination unit 92.

After a sufficient number of data that covers the above applying pressure range of the pressure bag 89 is sampled, the blood pressure determination unit 92 determines the blood pressure. The highest applying pressure from the pressure bag 89 that is detected as the vibration caused by the blood flow in the blood vessel in the narrowed state by the pressure sensor 90 is defined as the maximum blood pressure, whereas the lowest applying pressure from the pressure bag 89 that is detected as the vibration caused by the blood flow in the blood vessel in the narrowed state by the pressure sensor 90 is defined as the minimum blood pressure. The principle of this blood pressure measurement is the same as that of stethoscopy in which the blood pressure is determined by monitoring vibration of the vessel wall caused by blood flow in the narrowed blood vessel at an abaxial side of the artery pressed by a wrist band.

The embodiments according to the present invention have been described above. The present invention, however, is not limited to these embodiments, and can include various modifications within the scope of the spirit of the present invention and the claims.

What is claimed is:

1. A meridian point-probing device, comprising:

- a pulse wave-detecting unit which detects pulse waves;
- a stimulation unit having an end that stimulates a position of skin of a trial subject;
- a memory unit which stores pulse waveforms detected by the pulse wave-detecting unit before and after the stimulation of the position by the stimulation unit; and

a meridian point determination unit which determines whether the stimulated position is a meridian point, according to the pulse waveforms stored in the memory unit, the meridian point determination unit including a waveform parameter calculation subunit that calculates a pressure parameter based on a point located on the pulse waveforms and determines whether the stimulated position is a meridian point, according to the pressure parameter.

2. A meridian point-probing device, comprising:

- a pulse wave-detecting unit which detects pulse waves;
- a stimulation unit having an end that stimulates skin of a trial subject;
- a memory unit which stores pulse waveforms detected by the pulse wave-detecting unit after the stimulation of a plurality of positions of the skin of the trial subject by the stimulation unit; and
- a meridian point determination unit which determines whether each of the stimulated positions is a meridian point, according to the pulse waveforms stored in the memory unit, the meridian point determination unit including a waveform parameter calculation subunit that calculates a pressure parameter based on a point located on the pulse waveforms and determines whether the stimulated position is a meridian point, according to the pressure parameter.

3. The meridian point-probing device according to claim 2, wherein the waveform parameter calculation subunit calculates the pressure parameter that includes at least one of a pulse pressure that is a differential pressure between a systolic blood pressure and a diastolic blood pressure, a post-ejection pressure that is a differential pressure between a blood pressure at a dicrotic notch and the systolic blood pressure, a dicrotic wave height that is a differential pressure between the blood pressure at the dicrotic notch and a maximum blood pressure of the dicrotic wave, a post-ejection pressure ratio that corresponds to the post-ejection pressure normalized by the pulse pressure, a dicrotic wave height ratio that corresponds to the dicrotic wave height normalized by the pulse pressure, a tidal wave height ratio that corresponds to the tidal wave height normalized by the pulse pressure wherein the tidal wave height is a differential pressure between the blood pressure of the post-ejection pressure and a maximum blood pressure of a tidal wave, or a pulse from the pulse waveforms stored in the memory unit.

* * * * *

专利名称(译)	经络点探测装置和疗效决定装置		
公开(公告)号	US6821255	公开(公告)日	2004-11-23
申请号	US10/224370	申请日	2002-08-21
[标]申请(专利权)人(译)	精工爱普生株式会社		
申请(专利权)人(译)	SEIKO EPSON CORPORATION		
当前申请(专利权)人(译)	SEIKO EPSON CORPORATION		
[标]发明人	AMANO KAZUHIKO		
发明人	AMANO, KAZUHIKO		
IPC分类号	A61H39/00 A61B5/021 A61H39/02 A61B5/053 A61B5/0245 A61H39/08 A61B5/00		
CPC分类号	A61B5/021 A61B5/02116 A61H39/02 A61B5/6826 A61B5/6838 A61B5/681 A61B5/0532		
优先权	2001251876 2001-08-22 JP		
其他公开文献	US20030125631A1		
外部链接	Espacenet USPTO		

摘要(译)

子午点探测装置包括：脉搏波检测单元，用于检测脉搏波；刺激单元，具有刺激试验对象的皮肤位置的端部；存储单元，用于存储由脉搏波检测单元检测的脉冲波形在刺激单元刺激位置之前和之后，根据存储在存储单元中的脉冲波形，用于确定刺激位置是否是子午线的子午点确定单元。可以以高再现性客观地确定子午点的位置。

