

(19) **United States**  
(12) **Patent Application Publication**  
**Fernandez et al.**

(10) **Pub. No.: US 2009/0318782 A1**  
(43) **Pub. Date: Dec. 24, 2009**

(54) **OBJECT CONDITION SENSING**

**Publication Classification**

(76) Inventors: **Dennis Sunga Fernandez,**  
Woodside, CA (US); **Irene Hu**  
Fernandez, Woodside, CA (US)

(51) **Int. Cl.**  
*A61B 5/00* (2006.01)  
*G06N 5/02* (2006.01)  
*G06F 17/00* (2006.01)  
*G06F 15/00* (2006.01)  
(52) **U.S. Cl.** ..... **600/301; 706/54; 700/90; 706/47;**  
702/188

Correspondence Address:  
**Sadler, Breen, Morasch & Colby, ps**  
**422 W. Riverside Ave, Suite 424**  
**Spokane, WA 99201 (US)**

(57) **ABSTRACT**

Embodiments are described for multi-sensor systems for real-time embedded monitoring of object senses and mixed-mode object conditions. In one or more embodiments, various sensors can separately provide disparate analog signals representing different measurable attributes regarding a sensed object. For example, sensors may separately sense temperature, pressure, or other biometric values. In some embodiments and according to specified rule sets or other qualifying parameters, a digital signal can be generated by a processor and/or controller to indicate one or more conditions of the sensed object according to sensor input values. Additionally or alternatively, a multi-sensor scheme may be coupled to a digital network and/or coupled thereto for simulation and/or communication applications.

(21) Appl. No.: **12/508,405**

(22) Filed: **Jul. 23, 2009**

**Related U.S. Application Data**

(60) Continuation of application No. 11/058,780, filed on Feb. 15, 2005, which is a continuation of application No. 09/949,257, filed on Sep. 7, 2001, now Pat. No. 6,922,664, which is a division of application No. 09/220,784, filed on Dec. 23, 1998, now Pat. No. 6,415,188.

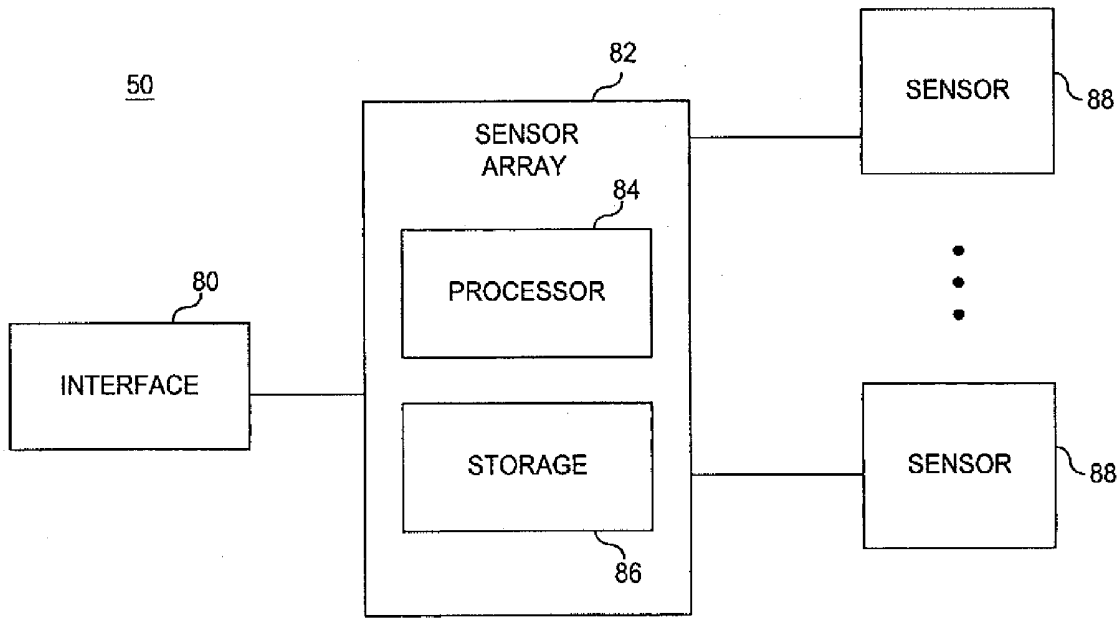

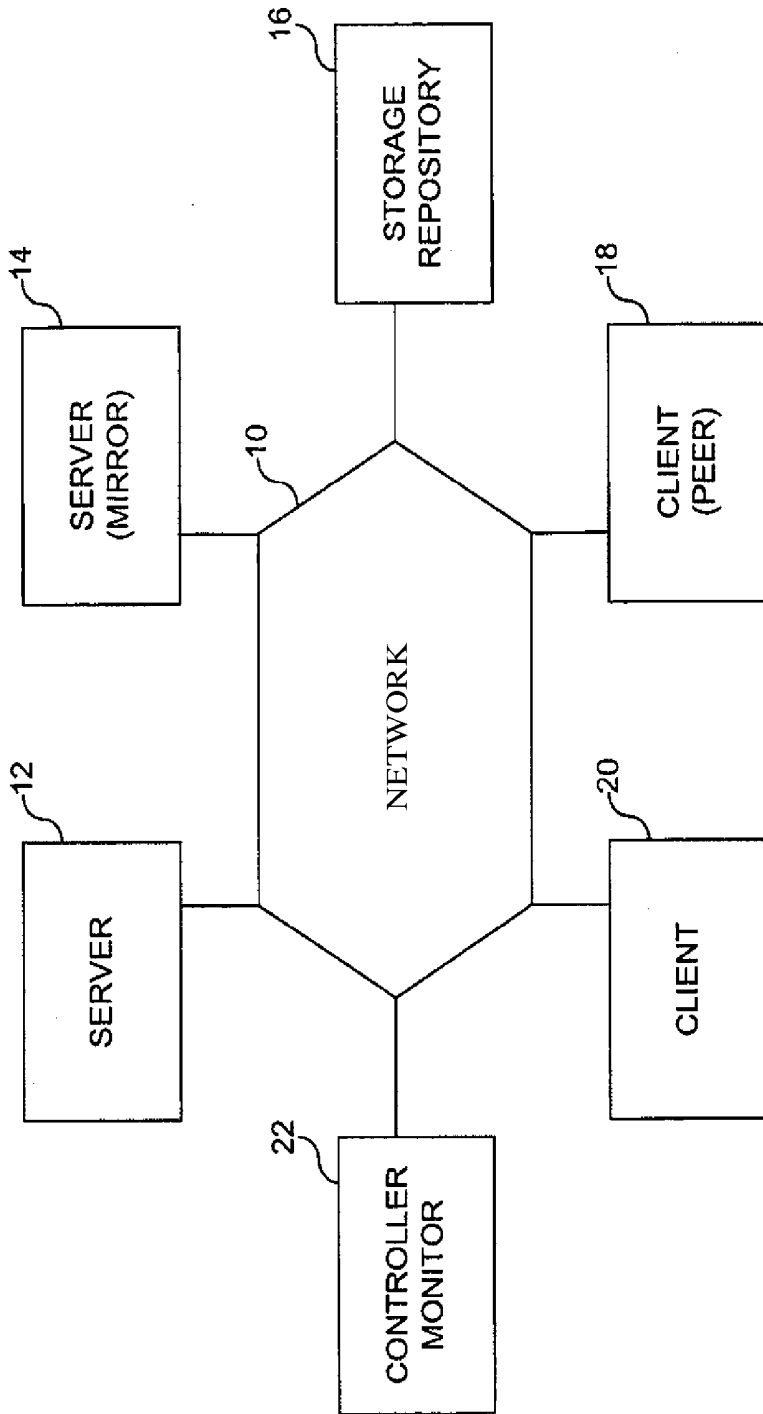

FIG. 1

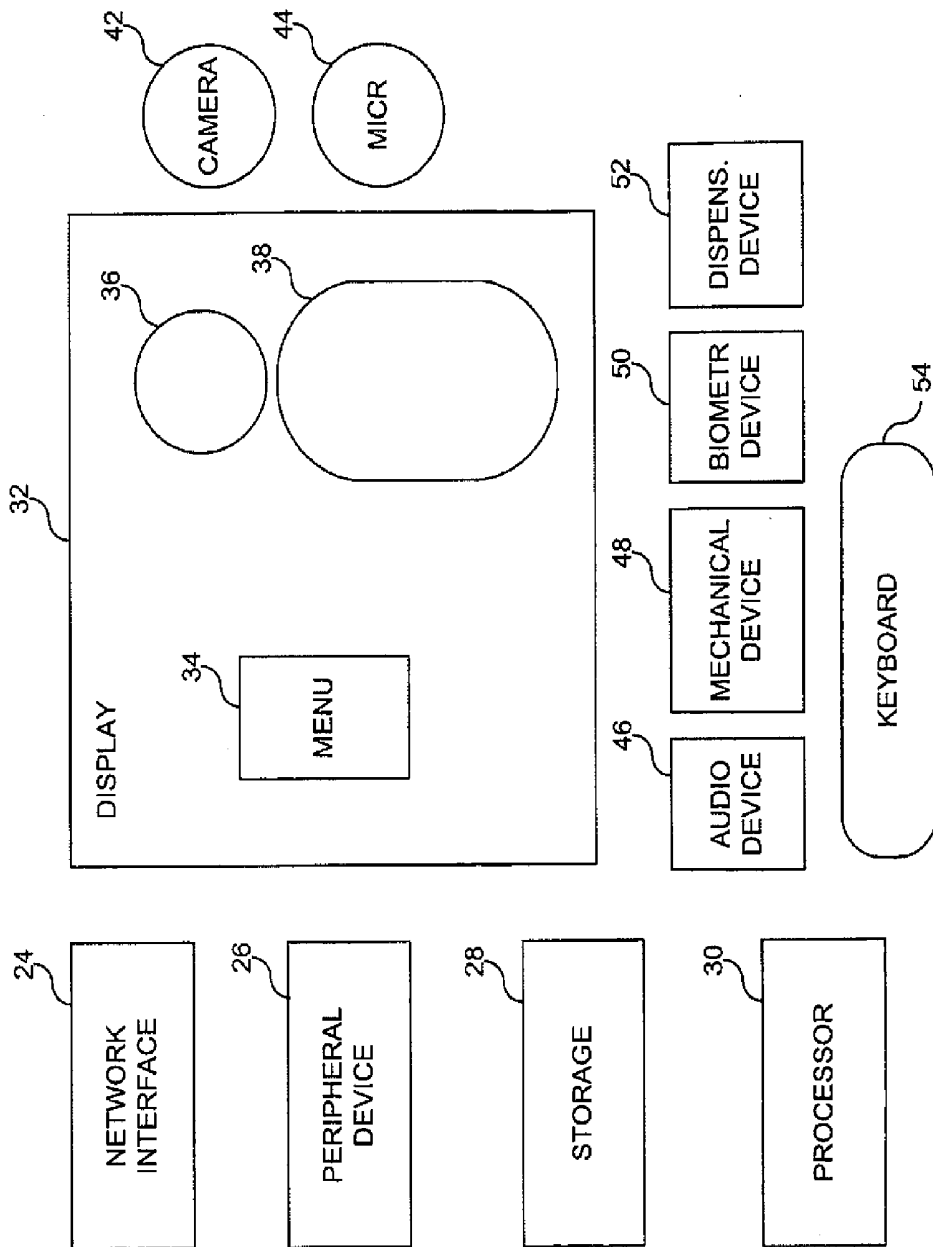
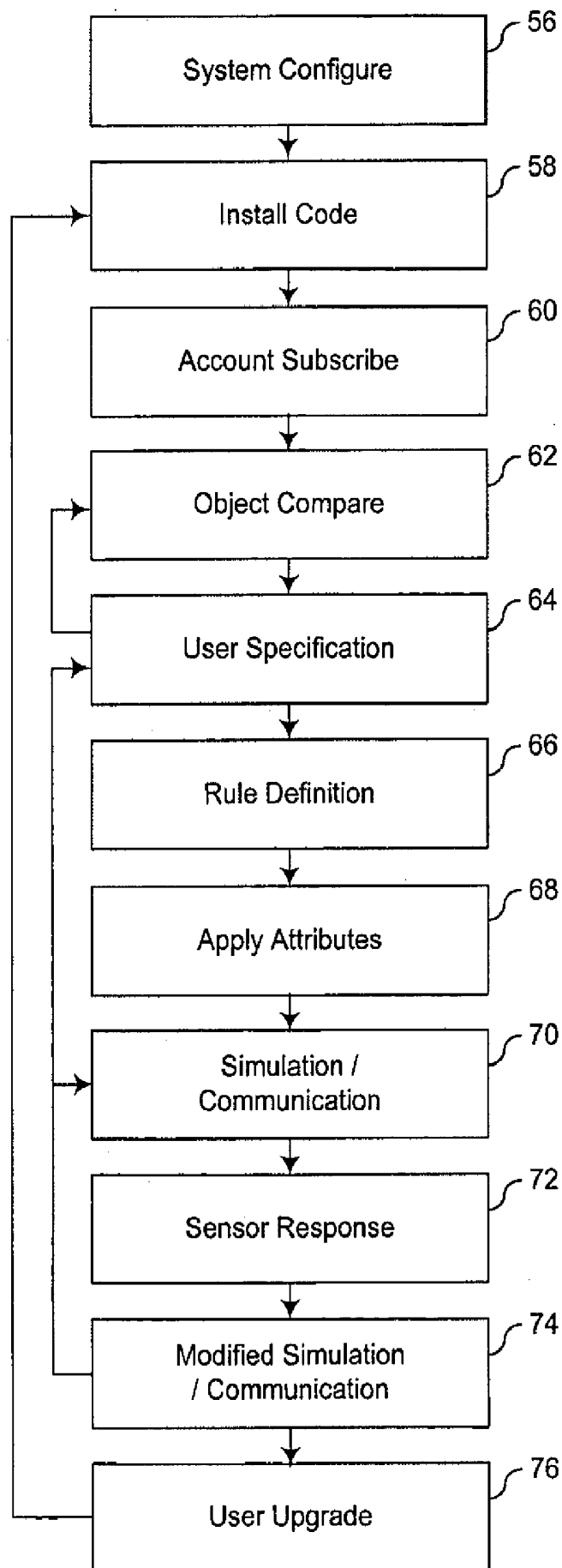

FIG. 2

**FIG. 3**



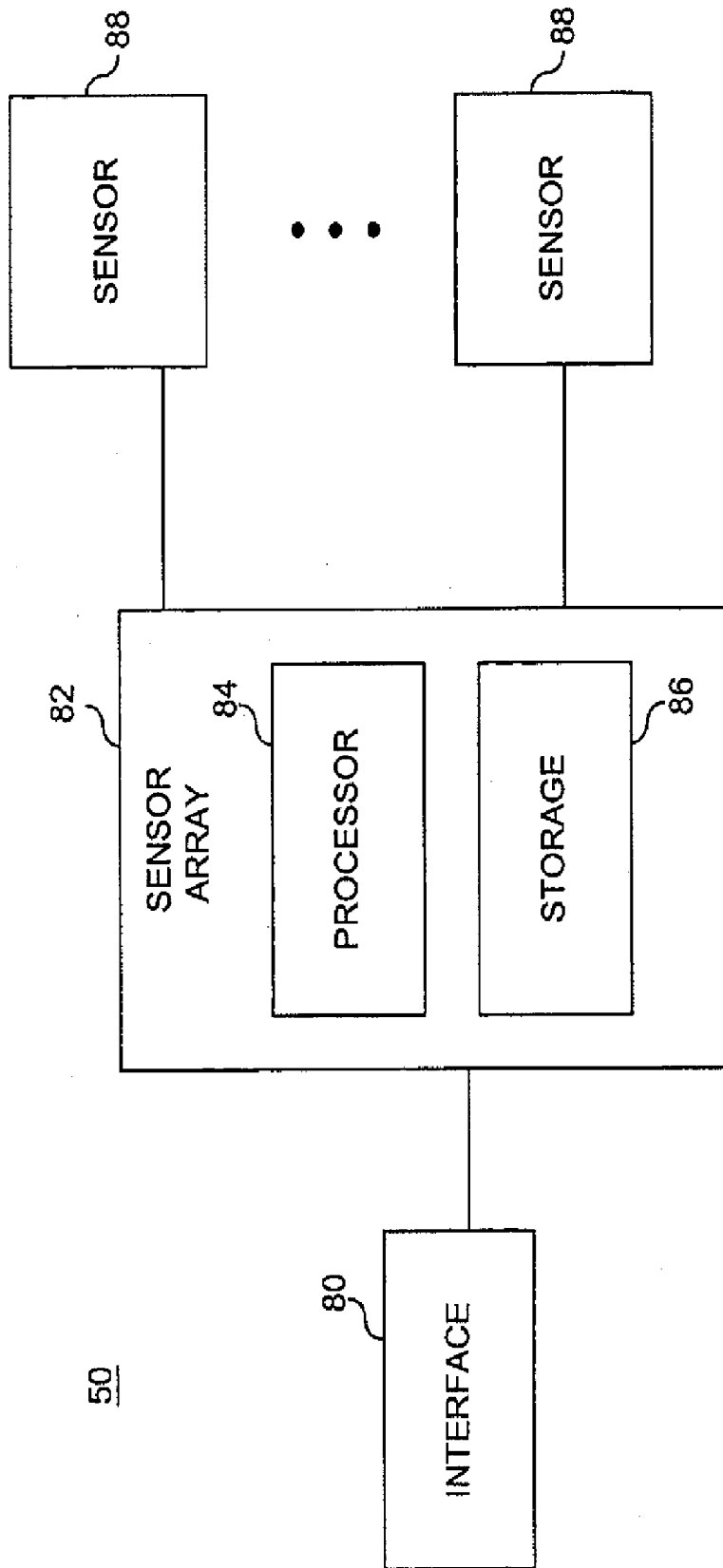
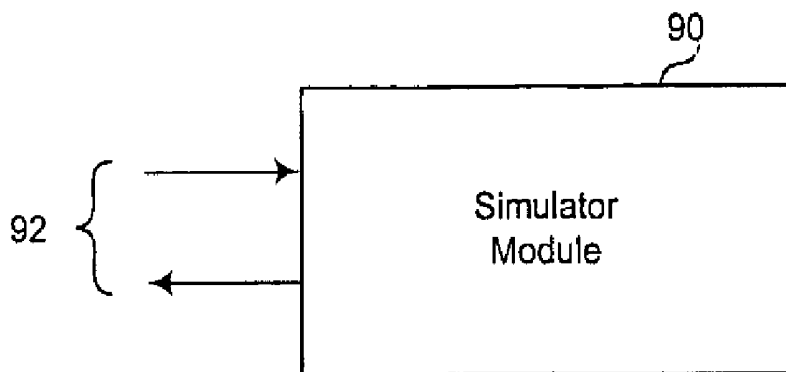
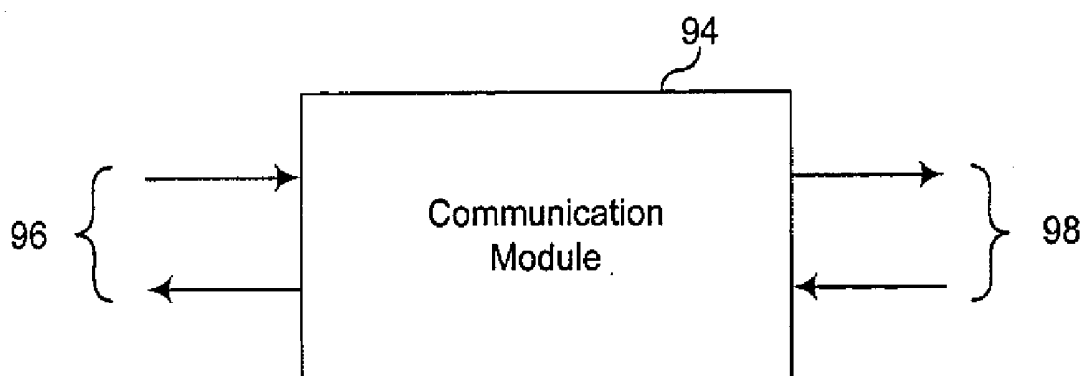

FIG. 4



**FIG. 5A**



**FIG. 5B**

## OBJECT CONDITION SENSING

### RELATED APPLICATIONS

[0001] This application is a continuation of and claims priority to U.S. patent application Ser. No. 11/058,780, entitled "Method and Apparatus for Multi-Sensor Processing," filed on Feb. 15, 2005, which in turn is a continuation of and claims priority to U.S. patent application Ser. No. 09/949,257, entitled "Method and Apparatus for Multi-Sensor Processing," filed on Sep. 7, 2001 and now issued as U.S. Pat. No. 6,922,664, which in turn is a divisional of and claims priority to U.S. patent application Ser. No. 09/220,784, entitled "Method and Apparatus for Multi-Sensor Processing," filed on Dec. 23, 1998 and now issued as U.S. Pat. No. 6,415,188, the disclosures of which are incorporated in their entirety by reference herein.

### BACKGROUND

[0002] Conventional electronic sensors are used in various industrial and commercial applications, for example, whereby certain transducer-type device may measure a physical condition and generate an electrical signal which represents such measured condition. Conventional sensors, however, typically generate analog signals and are not designed to interface easily to digital networks. Although more recently, electronic industry attention has increasingly turned toward coupling so-called embedded processing elements to digital networks, such recent approaches provide limited capability in processing multi-sensor systems, particularly for digital networks.

### BRIEF DESCRIPTION OF DRAWINGS

[0003] FIG. 1 is general system and network diagram according to one or more embodiments.

[0004] FIG. 2 is block diagram of a client according to one or more embodiments.

[0005] FIG. 3 is flow chart of steps in a method according to one or more embodiments.

[0006] FIG. 4 is a block diagram of biometric and/or multi-sensor modules according to one or more embodiments.

[0007] FIG. 5A is a diagram of a simulator module according to one or more embodiments.

[0008] FIG. 5B is a diagram of a communication module according to one or more embodiments.

### DETAILED DESCRIPTION

[0009] Embodiments discussed herein include multi-sensor systems and methods that can enable interactive sensing of mix-signal attributes to determine one or more object conditions. Sensors can separately measure different physical attributes to generate corresponding analog signals. According to one or more specified rule sets and/or other qualifying parameters, a digital signal can be generated by a processor and/or controller to represent one or more conditions of the sensed object according to such sensor signals. According to some embodiments, multi-sensor schemes may be coupled to a digital network or electronic facility for simulation and/or communication.

[0010] FIG. 1 illustrates a general diagram of a digital system having an interconnected network 10 configured to couple servers 12, 14, clients 18, 20, a storage repository 16, and a controller 22. The network 10 may include one or more local, medium or wide area interconnections or other digital

wired or wireless linkages accessible according to one or more standard networking protocols, such as the Internet, World-Wide Web, TCP/IP, or other Internet Protocol (IP) convention. The clients 18, 20, servers 12, 14, controller 22, and storage 16 may include one or more network-accessible computers, processors, controllers or other system nodes for processing and/or storing digital data.

[0011] According to some embodiments, the server 14 can serve as a fault-tolerant functional mirror or data replication facility for server 12, such that servers 12, 14 can be managed to store some or all of the same data. Additionally or alternatively, the client 18 can serve as a peer of the client 20, such that client-to-client communication may be accomplished for direct data or signal transfer therebetween. According to some embodiments, the storage repository 16 can serve as one or more network-accessible peripheral storage or memory facilities for storing digital data, such as the temporary caching of simulation data, communications data, control files, and/or signals.

[0012] In some embodiments, the controller or monitor 22 can serve as one or more network-accessible computing or processing facilities for enabling sensing and/or related functions or other network system management tasks, according to one or more embodiments described herein. For example, the controller 22 may serve as a system manager for initializing, coordinating, and/or controlling network tasks or other client-server distributed applications, such as video-conferencing or simulation programs executed among a number of client users coupled to the network.

[0013] FIG. 2 illustrates a block diagram of the client 20 according to one or more embodiments. In this particular example, the client 20 includes a video or screen display 32, a network interface 24, a peripheral device 26, a storage or memory 28, a processor 30, a speaker or audio device 46, an actuator or mechanical device 48, a sensor or biometric device 50, a dispenser device 52, a keyboard or mouse device 54, a camera 42, and a microphone 44. The display 32 may include a graphics-based user menu interface 34 and one or more symbolic, simulated, video, animated, or otherwise graphics-based depictions of individual or objects 38 having an identifiable face 36, icon, avatar, or other representation thereof.

[0014] In some embodiments, the display 32 may provide visual information according to holographic, 3-dimensional, virtual reality, or other similarly enhanced graphic dimensional effects. The speaker or audio device 46 may provide multi-channel or other enhanced stereoscopic or "surround-sound" effects. Additionally or alternatively, the mechanical device 48 may operate as a micro or miniaturized actuator, a robotic link, a vibrator, or other movable element. The dispenser device 52 may electro-mechanically provide a client user with requested, programmed, or otherwise computer-assisted packaged goods, medicine, liquids, solutions, consumable items, and/or other dispensable material.

[0015] In some embodiments, the dispenser device 52 may indicate to the server 12, 14 or other network node one or more current conditions related to dispensing material, such as a remaining amount. Optionally or additionally, one or more sensors may be implemented on the keyboard 54 or mouse device, such that user finger or hand condition sensing can be facilitated.

[0016] It is contemplated herein that client 20 may be configured, at least in part, by assembling a conventional personal computer, a TV set-top device, a laptop, a palmtop, an

engineering workstation, a computer-implemented automated transaction booth or “kiosk”, and/or other network-accessible processing node, which is programmed and equipped to function according to one or more embodiments described herein. In some embodiments of the present invention, it is further contemplated that the biometric device or sensor array module **50** may be coupled directly to the network **10**, without being included in, or having to couple through, the client **20**.

**[0017]** FIG. **3** is a flow chart illustrating steps in a method for implementing a multi-sensor system for real-time embedded monitoring of one or more objects under mixed-mode sensing conditions in accordance with one or more embodiments. Further, in this regard, as shown in the block diagram of FIG. **4**, the biometric sensing device **50** can include a network interface **80** and/or various sensors **88** for separately providing, through analog-to-digital (A/D) converter circuit, to a processor **84** and a storage **86** of a sensor array **82** disparate analog signals representing different measurable attributes regarding sensed object.

**[0018]** According to some embodiments, sensor subsystem integration can be achieved through a microelectromechanical systems (MEMS) approach by providing most or all electronic circuits, including the processor **84**, the storage **86**, the interface **80**, the sensors **88**, and/or any A/D converter circuits on a common semiconductor substrate or die, although the interface **80** and/or the sensors **88** can be provided on separate substrates or dice. In some embodiments, it is contemplated that multiple sensors may be coupled and provide mix-mode sensed signals to a common processing circuit.

**[0019]** In some example embodiments, one or more sensor modules may be implemented, at least in part, for functional operation according to some embodiments described herein, using commercially available devices, such as product part numbers EDI 520 (smart sensor module), EDM 710 (sensor interface circuit), and/or RS-485 (network node) from Electronics Development Corporation (Columbia, Md.).

**[0020]** According to some embodiments, one set of one or more sensors **88** may sense and monitor one type of object condition, and another set of one or more sensors **88** may sense and monitor another type of object condition. For example, for a given individual subject being monitored, a first sensor set may monitor person temperature at one or more bodily sources, while a second sensor set may monitor same person perspiration rate at one or more bodily sources.

**[0021]** In some embodiments, such multi-sensor set system can monitor related and/or possibly unrelated conditions associated with a common object or object set that is monitored during simultaneous, temporally close, or otherwise relatively proximate time periods. In accordance with some embodiments, the sensor array processing circuitry **82** can operate to receive multi-sensor signals which indicate sensed conditions representing different sensor or sensing signal types, classes, attributes, and/or other monitorable grouping, and thus process such effectively mix-mode signals to determine whether certain monitored object(s) or individual(s) previously, currently, or is likely to, fall within certain specified condition(s), as determined by processing such mix-mode sensor signals.

**[0022]** Some embodiments can utilize a mix-mode approach whereby signal processing by the processor **84** can be performed in an effectively combined and integrated manner according to one or more common rule sets, user specifications, and/or other programmed instructions, which can

classify and indicate one or more monitored object conditions or sensed states logically or inferentially according to actual input sensed signal values corresponding to different modes or other physically measured groupings.

**[0023]** In some embodiments, to achieve improved overall system or partial subsystem integration, the processor **82** or functionally comparable digital signal processing circuit can serve separately to receive and process multiple-type sensor signals or signal sets, whereupon such sensor signals or signal sets represent different physically sensed or otherwise electronically monitorable conditions, states, attributes, modes, or quality of sensing thereof.

**[0024]** For example, the processor **84** may locally execute an instruction set in the storage **86** to analyze, compare, correlate, and/or process received mix-mode signals according to specified rules or heuristics to indicate remotely whether subject individual may be diagnosed as having symptoms of one or more medical conditions, and therefore require dispensing of certain medicines or other goods or supplies. Such “smart sensor” processing and analysis may also be accomplished using a digital signal processor having logically or functionally equivalent programming and/or circuit configuration.

**[0025]** Thus, according to some embodiments, such intelligently determined conditions may be generated as findings, flags, warnings, or other indications provided as feedback in a digital packet, datagram, frame, or other capsulized format through the interface **80** for network access, for example, to serve as input values to the simulator module **90** for fantasy gaming applications, or the communication module **94** for video-conferencing applications. Optionally or additionally, the interface **80** may provide sensor feedback data signal through the network **10** according to one or more established or known network or bus interface standards, such as IEEE 1451 standard for interfacing to smart sensors.

**[0026]** In some embodiments, the sensors **88** may be fixed, mobile, wirelessly-connected or wired, and separately sense temperature, pressure, physiological vital information (e.g., heart beat rate, blood pressure, etc.), and/or other biometric values. For example, one or more sensors in the array **82** may be worn, implanted, attached, or provided by individual objects on clothing or vehicle, and/or provided in contact thereto with one or more external or internal bodily locations.

**[0027]** In some embodiments, it is contemplated herein that the sensors **88** may be provided, for example, as one or more silicon-based micro-machined microstructure cavities which may be implanted for applicable modes such as neuro-electronic monitoring of cell metabolism and/or controlling of cell activity.

**[0028]** According to one or more embodiments, the sensors **88** may be configured to monitor one or more voluntary and/or involuntary conditions, such as distinct sensory modes, of a subject user or other observed party, such as skin temperature, perspiration rate, or other measurable physiological conditions. In particular, the sensor array **82** can operate in an intelligent or “smart” manner, such that, for example, distributed sensors, actively or passively, synchronously or asynchronously, sense and generate sensing signals according to pre-programmed logical rules and/or other user specifications, such as determining acceptable manufacturing tolerance or safety conditions.

**[0029]** In some embodiments, the sensor array **82** can function selectively or logically to screen, filter, censor, and/or exclude or enable access of representative signaling of certain

sensed or otherwise observed conditions, such as during specified times, dates, or other specified temporal segments, such as control of mature-audience programming. For example, within given monitoring period, the processor **84** may compute or compare to determine, and accordingly indicate for network access, that received sense signals comply or violate a certain specified range, or fall within particular margins. Optionally or additionally, the processor **84** may selectively access one or more of the sensors **88** belonging to one or more selected modes, groupings, or other pre- or user-specified classifications, such as higher-resolution, reliability, or quality sensor groups.

**[0030]** Additionally or alternatively, in some embodiments the present distributed sensor array architecture may provide for directed, hierarchical, self-navigating and/or organizing, adaptive, or flexibly programmable access to one or more sensors in the array **82**, such as by providing tiered quality of service access to varying levels of sensor sensitivity, reliability, accuracy, performance, or other relevant sensor parameters.

**[0031]** In some hierarchical-style embodiments, a first set of mix-mode sensed signals can be received for processing as described herein to generate a first processed signal indicating one monitored mode or other level of functional abstraction, which represents a logical determination according to rule-based interpretations or analyses of the first set of received mix-mode signals. According to some embodiments, a second set of mix-mode sensed signals can then be received for processing as well to generate a second processed signal indicating another monitored mode or other level of functional abstraction, which represents a different logical determination according to rules-based interpretation and/or analysis on such second set of received mix-mode signals.

**[0032]** According to some embodiments, such mix-mode first and second processed signals can be received, in hierarchical or tiered fashion, for further processing according to rules-based interpretation and/or analysis as described herein to generate a third processed signal to serve as sensory feedback according to higher-level monitored mode and/or other level of functional abstraction.

**[0033]** In some embodiments and according to specified rule set or other qualifying parameters, a digital signal can be generated by the processor or controller **84** to indicate one or more conditions of the sensed object according to sensor input values. Additionally or alternatively, referring to FIGS. **5A** and **5B**, such multi-sensor scheme may be coupled to the digital network **10** and/or coupled thereto for simulation and/or communication applications **90**, **94**, as described in more detail herein.

**[0034]** Referring to FIG. **3**, initially, the multi-sensor system can be configured **56** functionally with system components as illustrated in FIG. **2**, and source or object software, computer program, or other instruction code can be installed **58** in such system for operation as described herein.

**[0035]** Optionally or additionally, one or more system users or corresponding clients **18**, **20** can subscribe **60** to, or can be otherwise provided with, authorized user or group user accounts for secure system access, for example, as a member for enabling exclusive access to one or more network-accessible programs, files, or other restricted objects. Authorization may be accomplished by identifiable user entry and/or other input through a keyboard, a mouse, voice, facial image recognition, finger print detection, retinal scan, smart card

input, or other unique user entry, for example, by using the peripheral device **26** as an input processing device.

**[0036]** Optionally or additionally, authorization may be provided by user entry of a unique password or other identifiable signature, such as genetic sequencing or other related data. Also, optionally or additionally, upon user authorization **60**, an authorized user may cause client **20** to conduct one or more comparison **62** of various objects available from a number of source nodes accessible through the network **10**.

**[0037]** In some embodiments, object compare **62** can enable a user to conduct on-line product catalog shopping and/or select one or more desired objects using a conventional network user interface, such as Internet browser application software. In this way, a user may specify **64** one or more objects for searching and subsequent comparison **62** thereof, enabling desired objects to be found and/or identified for a subsequent transaction. Furthermore, an identifiable user entry for authorization purposes can provide a server source with a tracking basis to bill or credit a user account for service, as well as to monitor and/or record user usage history, behaviors and/or preferences.

**[0038]** In some embodiments, the server **12** or the storage **16** may serve as network-accessible sources for requesting, searching, renting, buying, and/or down-loading various software components, upgrades, or other code or data, such as text, graphics, audio, video, models, vectors, images, fantasy or sports games, instructions, commands, or other electronically transmittable messages or signals, which are sensed, user-selected and/or programmed or monitored according to one or more embodiments discussed herein.

**[0039]** According to some embodiments, the source server **12** and/or the controller **22** may monitor usage and/or license distribution, usage or copying of such down-loaded software to certain target or requesting clients **20**, **18**. Additionally or alternatively, in a code distribution scheme, the network **10** can serve as a real-time or interactive channel, architectural interface, or transaction platform for enabling secure subscription by multiple users or clients, particularly for providing multi-sensor related applications.

**[0040]** Optionally or additionally, in some embodiments a user may define **66** one or more rules and/or other heuristic instruction sets according to one or more high-level functional or programming languages or application programming interfaces, which may be applied as attributes and/or conditions **68** to a sensing scheme, as described herein. For example, applied attributes **68** may include user-selected object characteristics, mappable facial imaging features, and/or language translation dictionary for processing simulated or communicated applications data.

**[0041]** In some embodiments, multi-sensor functionality can be implemented in the context of, or overlaid upon, simulation and/or communication **70**, respectively using simulator module **90** and/or communication module **94**, as shown in FIGS. **5A** and **5B**. For example, sensor functionality can provide input/output sensed signals **92**, **96**, **98**, whereupon certain sensor signals can be generated **72** in response to detection and measurement of physical conditions or attributes.

**[0042]** Regarding deployment of simulator module **90**, in some embodiments the client **20**, **18** can be provided with, and/or have access to, one or more software and/or hardware-based simulation or emulation programs or functionalities for representing the logic, behavior, functionality or other simu-

latable attributes of a modeled design, operation, condition, prototype, component, circuit, environment, or other computer-representable entity.

**[0043]** In some example embodiments, the simulator module **90** may include one or more commercially-available computer-implemented simulation programs which operate using, at least in part, one or more simulation models. Thus, during simulation of such provided models, one or more input vectors, data or other signals can be applicable thereto, such that the simulator may compute and thereby generate one or more proper output vectors, data or other signals responsively therefrom. Such output signals may cause one or more client output devices, such as the audio device **46**, the mechanical device **48**, the display **32**, and/or the dispenser device **52** to function accordingly and/or interact responsively with client use.

**[0044]** In some example embodiments, the simulator module **90** may be embodied to provide single and/or multiuser interactive gaming, therapy, and/or exercise functionality. In some embodiments, such simulation functionality can operate in response to, among other things, multi-sensor input signals to enhance a simulation experience, as generated according to one or more embodiments discussed herein.

**[0045]** According to some embodiments and regarding deployment of the communication module **94**, the client **20**, **18** can be provided with, or has access to, one or more software and/or hardware-based communications programs, functionalities, or other facilities for transmitting and/or receiving communications signals for bidirectional or duplex signal interaction between a number of network-accessible processors or other nodes therein. For example, the communication module **94** may be embodied in a videoconferencing system configured between two or more networked computers for effectively real-time exchange of images and/or live video between communicating clients or peer parties. In some embodiments, such communication can functionality operate by transmitting and/or receiving, among other things, multi-sensor signals to enhance communication experience, as generated according to one or more embodiments discussed herein.

**[0046]** Further to some embodiments and in accordance with such sensor response, at block **74** the communication and/or simulation modules **94**, **90** and/or prior user specification may be modified, corrected, and/or changed. Optionally or additionally, from time to time, client software and other system parameters may be updated, such that client and/or system code may be remotely programmably upgraded or remapped **76**.

**[0047]** In some embodiments discussed herein, a multi-sensor system is provided for networked cooperation or feature overlay with simulators and/or video-conferencing applications, whereupon, for example, conventional networked, interactive fantasy gaming programs and/or video-conferencing systems are enabled with effectively enhanced input or physical sensing of user or other object associated therewith.

**[0048]** In some embodiments an overlaid approach can be utilized to enable variously categorized sets of real-time sensory feedback to be collected, computed, and/or transmitted from one or more smart sensor arrays to provide additional advanced ways for improving networking and control, and thereby raise the level and quality of electronic communication and general user interactivity.

**[0049]** Foregoing described embodiments are provided as illustrations and descriptions. They are not intended to limit the scope of the claimed embodiments to the precise forms or applications described. In particular, it is contemplated that functional implementations of the embodiments described herein may be implemented in hardware, software, firmware, and/or other available functional components or building blocks for various sensor-related commercial, industrial, medical, educational, media, broadcast, entertainment, food, agriculture, clothing, retail, fashion, defense, military, aerospace, automotive, transport, shipping, construction, design, finance, biotech, manufacturing, electronic, security, communications, information, or other related applications, systems or implementations.

**[0050]** Other variations and embodiments are possible in light of the discussion herein, and it is thus intended that the scope of invention not be limited by this Detailed Description.

1. A sensor architecture comprising:

- a first sensor configured to monitor a first physical attribute of an object and generate a corresponding first signal;
- a second sensor configured to monitor a second physical attribute of the object and generate a corresponding second signal, wherein the first and second sensors are configured to be coupled as peers on a network;
- a sensor array configured to control accessibility of the first and second sensors and to process the first signal and the second signal to indicate one or more physiological conditions associated with the object; and
- an output device configured to provide output based on the one or more physiological conditions.

2. The sensor architecture of claim 1, wherein the output is a video signal.

3. The sensor architecture of claim 1, wherein the output is configured to enable a client device to implement one or more of gaming, therapy, or exercise functionality.

4. The sensor architecture of claim 1, wherein one or more of the first signal or the second signal are configured to be utilized to diagnose one or more medical conditions.

5. The sensor architecture of claim 1, wherein the output device is configured to dispense one or more medications.

6. The sensor architecture of claim 1, wherein the output device comprises one or more of:

- a display device;
- an audio device;
- a dispenser device; or
- a mechanical device.

7. The sensor architecture of claim 1, wherein one or more of the first physical attribute or the second physical attribute comprises one or more of:

- temperature;
- perspiration rate; or
- blood pressure.

8. An apparatus comprising:

- a first sensor configured to monitor a first physical condition of an object and generate a corresponding first signal according to a first rule;
- a second sensor configured to monitor a second physical condition of the object and generate a corresponding second signal according to a second rule; and
- a storage configured to provide the apparatus with one or more of the first rule or the second rule according to one or both of a usage license or subscription.

9. The apparatus of claim 8, further comprising a sensor array configured to process the first signal and the second signal to indicate one or more physiological conditions associated with the object.

10. The apparatus of claim 8, wherein one or more of the first signal or the second signal are configured to enable the apparatus to implement one or more of gaming, therapy, or exercise functionality.

11. The apparatus of claim 8, wherein one or more of the first sensor or the second sensor are configured to monitor one or more of the first physical condition or the second physical condition via contact with a person.

12. The apparatus of claim 8, wherein the output signal is configured to cause the apparatus to perform a function associated with a physiological condition indicated by one or more of the first physical condition or the second physical condition.

13. The apparatus of claim 12, wherein the apparatus comprises one or more of:

- a display device;
- an audio device;
- a dispenser device; or
- a mechanical device.

14. A tangible computer-readable medium having stored thereon, computer-executable instructions that, if executed by a computing device, cause the computing device to perform a method comprising:

monitoring a first physical condition of an object with a first sensor to generate, according to a first rule, a corresponding first signal;

monitoring a second physical condition of the object with a second sensor to generate, according to a second rule, an associated second signal, wherein the first sensor and second sensor are coupled as peers on a network, and wherein each of the first sensor and second sensor is accessible on the network based on one or more sensor parameters; and

determining a physiological condition of the object based on the first signal and the second signal.

15. The tangible computer-readable medium of claim 14, wherein the method further comprises:

monitoring a third physical condition of the object with a third sensor to generate, according to a third rule, a corresponding third signal, wherein the third sensor is coupled to the first and second sensors as peers on the network, and wherein the third sensor is accessible on the network based on one or more of the sensor parameters; and

determining the physiological condition of the object based additionally on the third signal.

16. The tangible computer-readable medium of claim 14, wherein the first sensor is configured to operate according to a high-level programming language or application programming interface.

17. The tangible computer-readable medium of claim 14, wherein data associated with one or both of the first signal or second signal is accessible to a client device.

18. The tangible computer-readable medium of claim 17, wherein one or both of the first signal or the second signal are configured to cause the client device to implement one or more of gaming, therapy, or exercise functionality.

19. The tangible computer-readable medium of claim 18, wherein one or both of the first signal or the second signal are configured to cause an output device associated with the client device to perform an output function comprising at least one of:

- producing sound;
- causing a display;
- producing video; or
- dispensing a good.

20. The tangible computer-readable medium of claim 14, wherein at least one of the one or more sensor parameters is associated with:

- sensor sensitivity;
- sensor reliability;
- sensor accuracy; or
- sensor performance.

\* \* \* \* \*

专利名称(译)	对象条件感知		
公开(公告)号	<a href="#">US20090318782A1</a>	公开(公告)日	2009-12-24
申请号	US12/508405	申请日	2009-07-23
[标]申请(专利权)人(译)	FERNANDEZ DENNIS SUNGA FERNANDEZ IRENE 胡		
申请(专利权)人(译)	FERNANDEZ DENNIS SUNGA FERNANDEZ IRENE 胡		
当前申请(专利权)人(译)	FERNANDEZ DENNIS SUNGA FERNANDEZ IRENE 胡		
[标]发明人	FERNANDEZ DENNIS SUNGA FERNANDEZ IRENE HU		
发明人	FERNANDEZ, DENNIS SUNGA FERNANDEZ, IRENE HU		
IPC分类号	A61B5/00 G06N5/02 G06F17/00 G06F15/00 G05B23/02		
CPC分类号	G05B23/0227		
外部链接	<a href="#">Espacenet</a> <a href="#">USPTO</a>		

摘要(译)

描述了用于多传感器系统的实施例，用于对象感觉和混合模式对象条件的实时嵌入式监视。在一个或多个实施例中，各种传感器可以分别提供表示关于感测对象的不同可测量属性的不同模拟信号。例如，传感器可以分别感测温度，压力或其他生物特征值。在一些实施例中并且根据指定的规则集或其他限定参数，可以由处理器和/或控制器生成数字信号，以根据传感器输入值指示所感测的对象的一个或多个条件。附加地或替代地，多传感器方案可以耦合到数字网络和/或耦合到数字网络以用于仿真和/或通信应用。

