



US 20090270691A1

(19) **United States**

(12) **Patent Application Publication**
Arizaga Ballesteros

(10) **Pub. No.: US 2009/0270691 A1**

(43) **Pub. Date: Oct. 29, 2009**

(54) **FLEXIBLE MEDICAL SENSOR ENCLOSURE**

Related U.S. Application Data

(75) **Inventor: Adolfo Arizaga Ballesteros,**
Pleasanton, CA (US)

(63) Continuation of application No. 11/528,293, filed on
Sep. 27, 2006, now Pat. No. 7,574,245.

Correspondence Address:
NELCOR PURITAN BENNETT LLC
ATTN: IP LEGAL
6135 Gunbarrel Avenue
Boulder, CO 80301 (US)

Publication Classification

(51) **Int. Cl. A61B 5/00** (2006.01)

(52) **U.S. Cl. 600/300**

(57) **ABSTRACT**

A sensor is provided that includes a flexible wrap enclosure which is folded about the sensor. The flexible wrap includes primary flaps and at least one reinforcement flap. The reinforcement flap may be used to enclose areas of the sensor not enclosed by the primary wrap and/or may be used to provide reinforcement of the enclosure to prevent tearing of the flexible wrap enclosure. The sensor may be placed on a patient's finger, toe, ear, and so forth to obtain pulse oximetry or other physiological measurements.

(73) **Assignee: Nellcor Puritan Bennett LLC,**
Boulder, CO (US)

(21) **Appl. No.: 12/491,940**

(22) **Filed: Jun. 25, 2009**

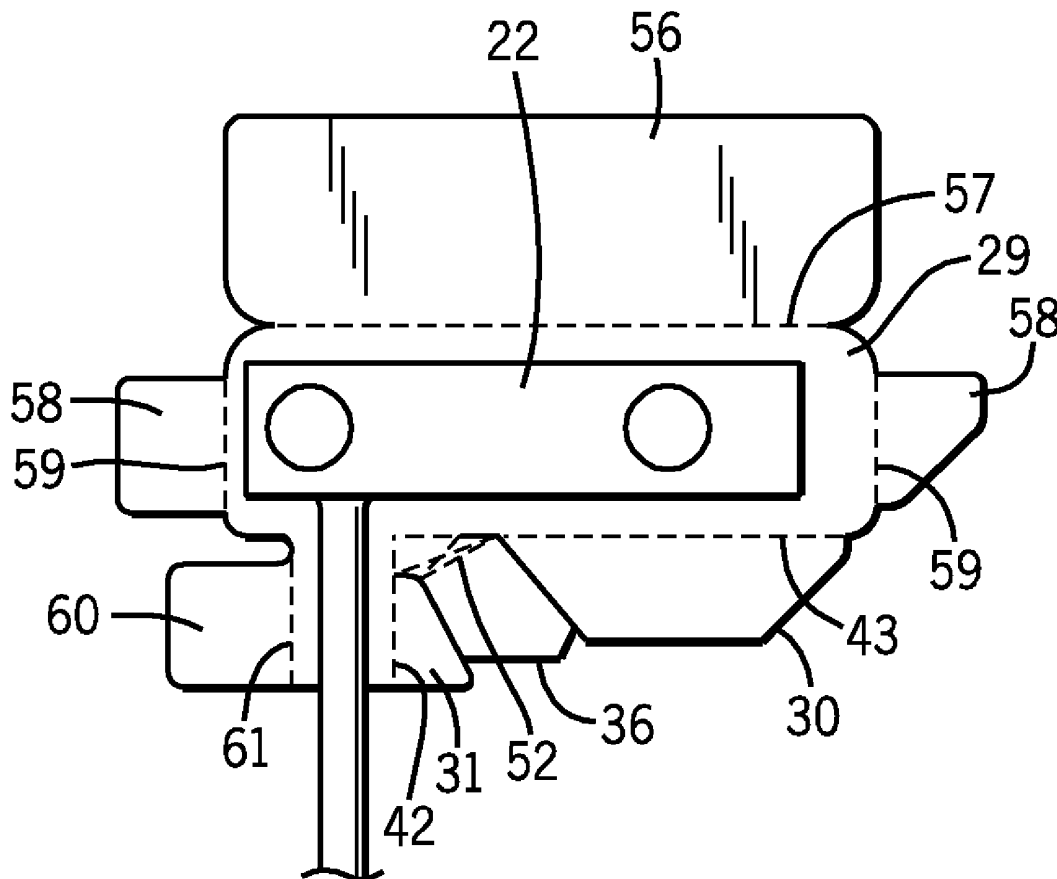

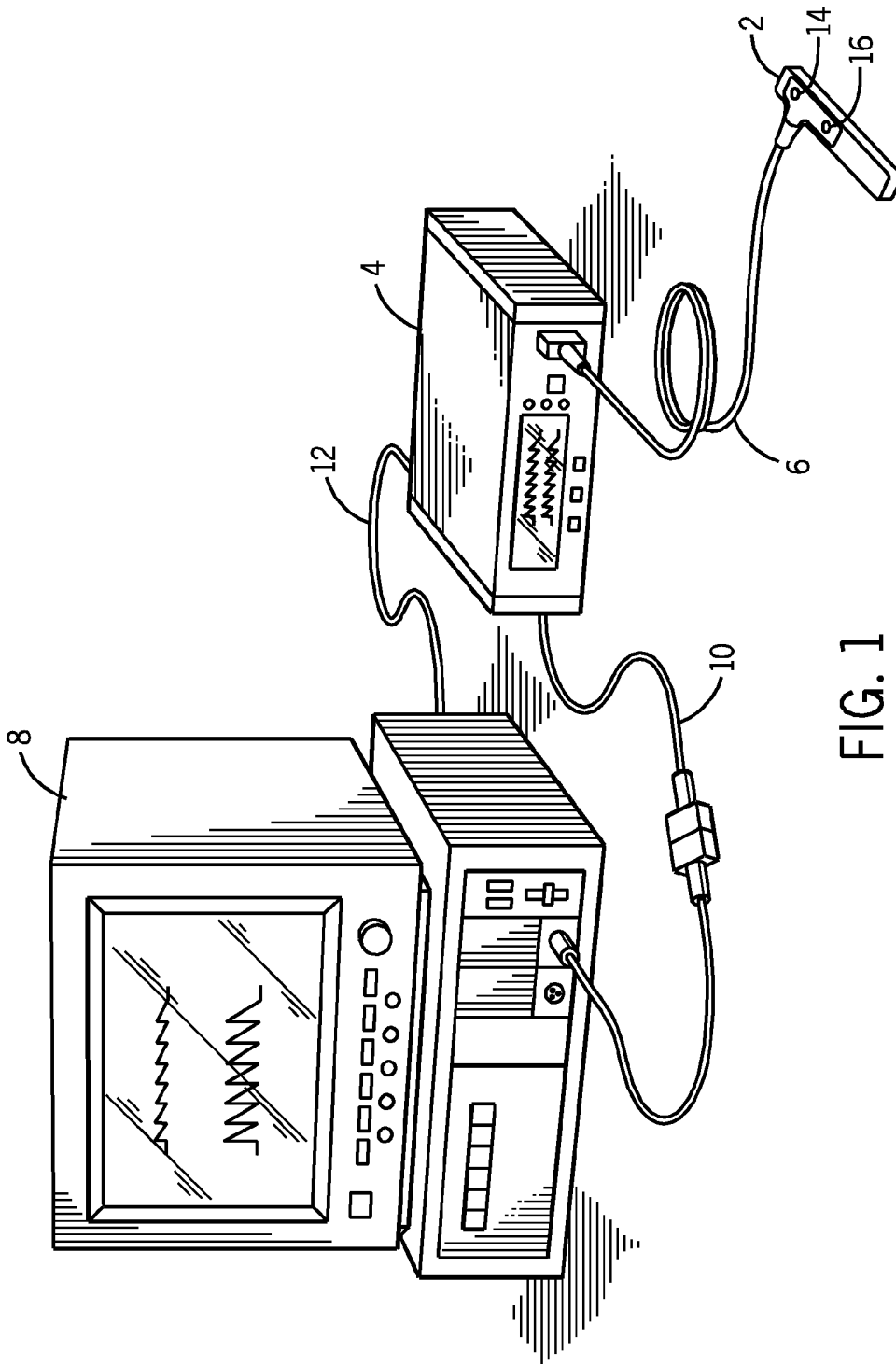

FIG. 1

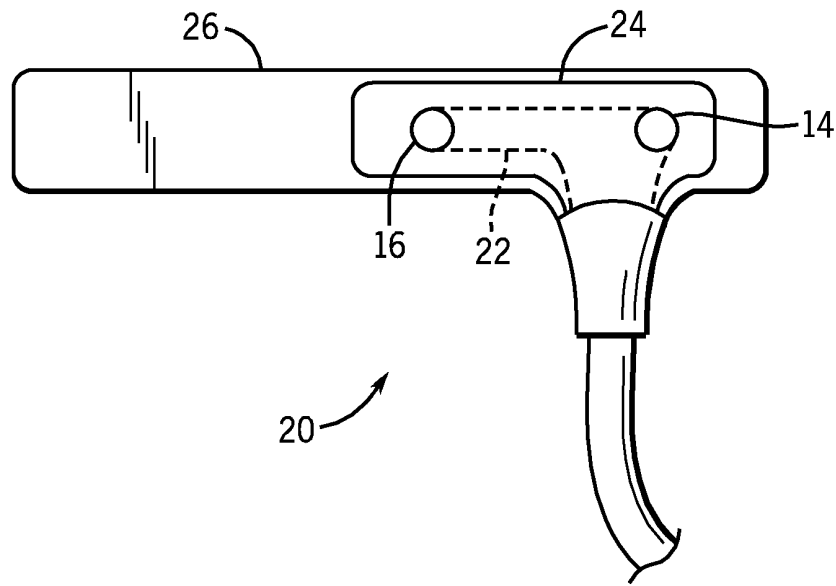

FIG. 2

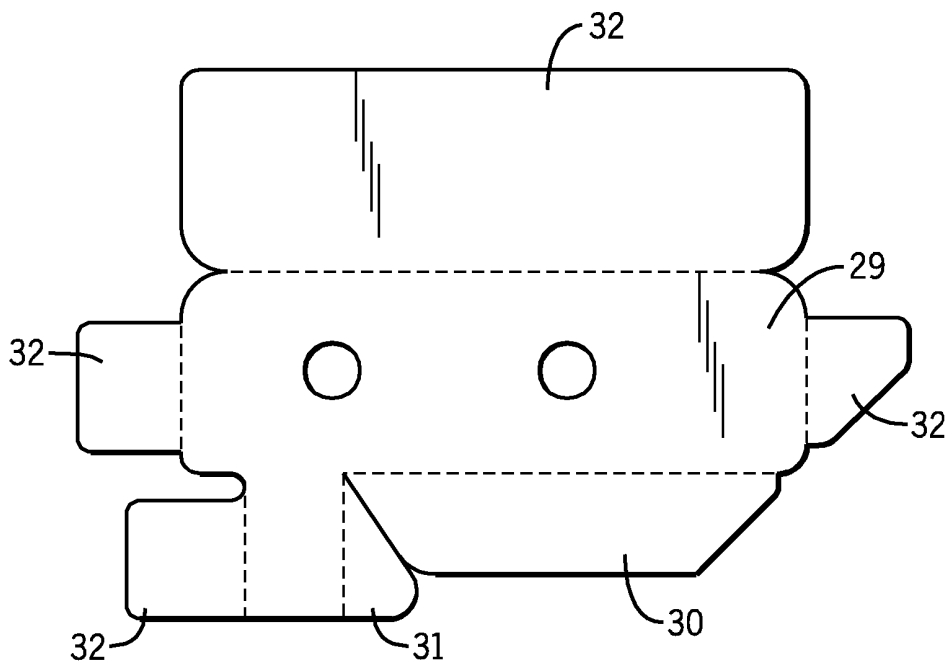

FIG. 3
PRIOR ART

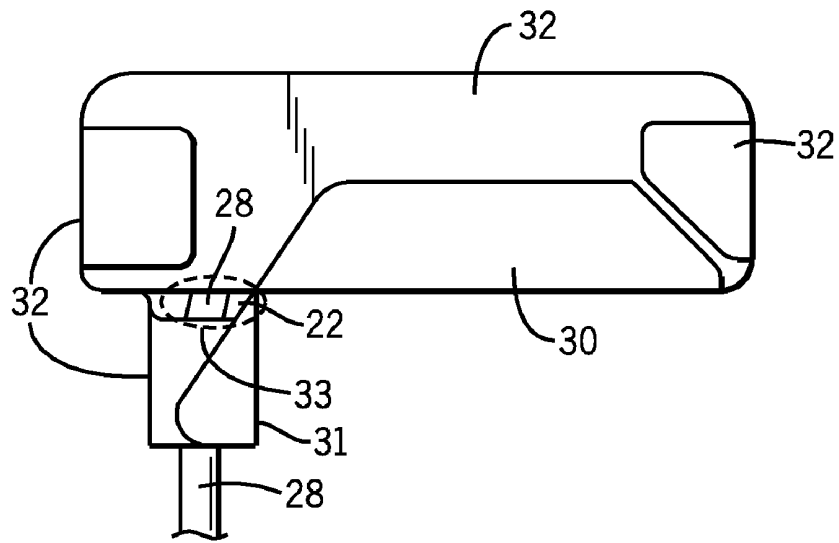

FIG. 4
PRIOR ART

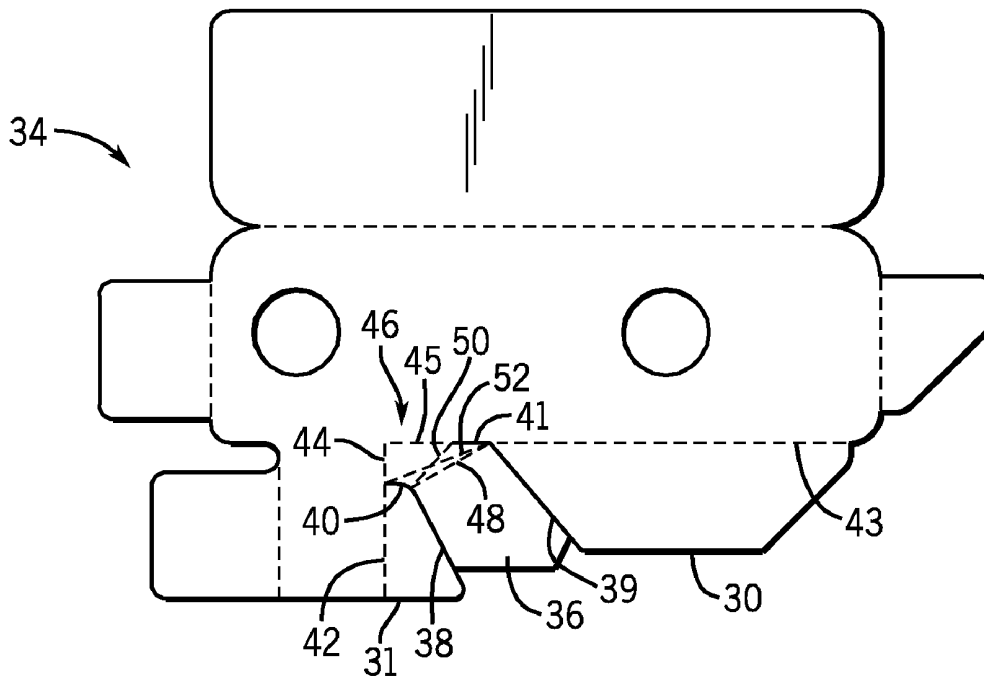

FIG. 5

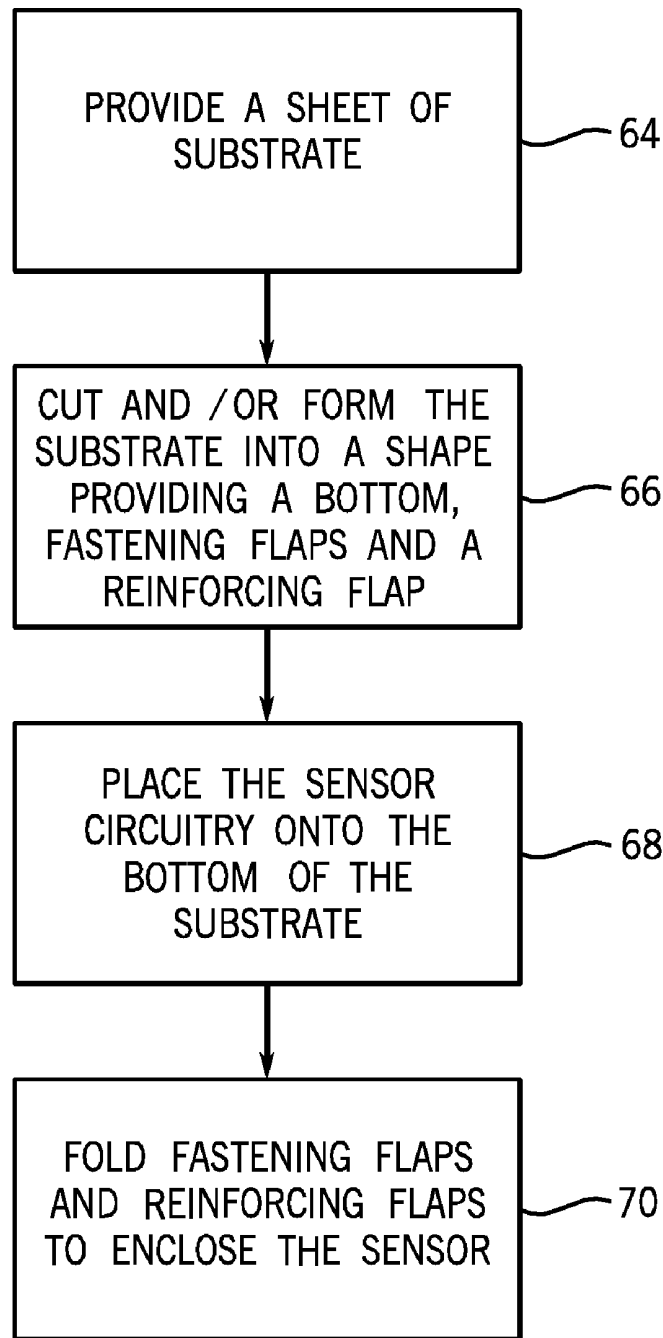

FIG. 6

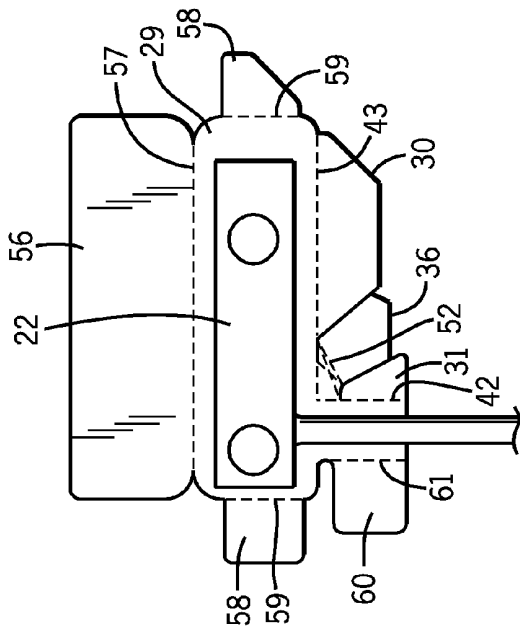

FIG. 7A

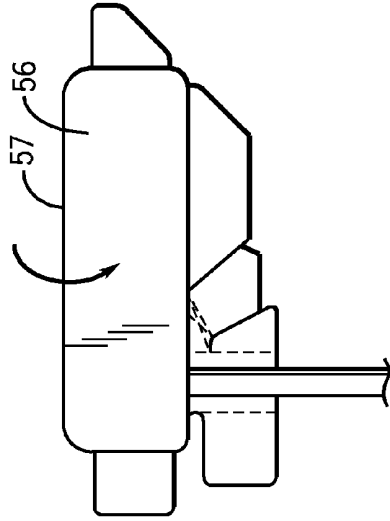

FIG. 7B

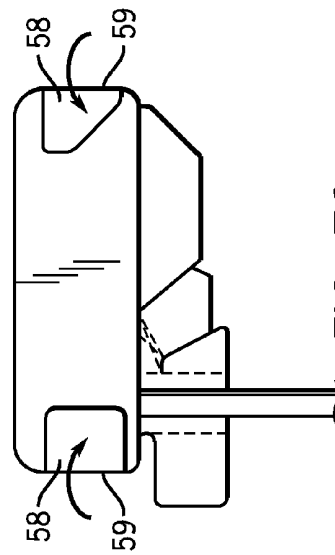

FIG. 7C

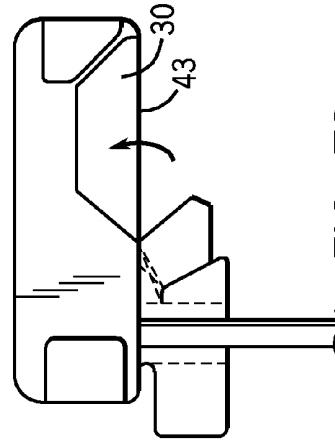

FIG. 7D

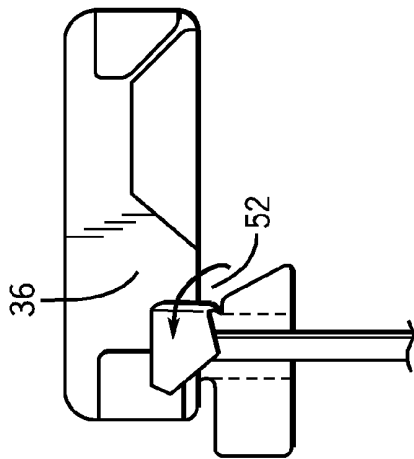

FIG. 7E

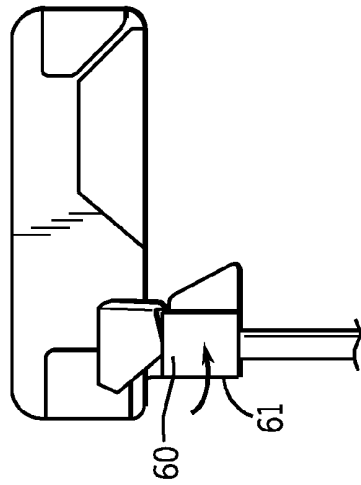

FIG. 7F

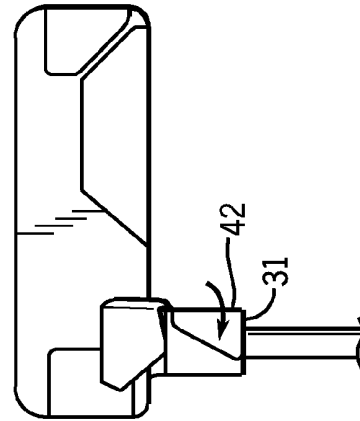

FIG. 7G

FLEXIBLE MEDICAL SENSOR ENCLOSURE

BACKGROUND OF THE INVENTION

[0001] This application is a continuation of U.S. application Ser. No. 11/528,293 filed Sep. 27, 2006, the disclosure of which is hereby incorporated by reference in its entirety.

[0002] 1. Field of the Invention

[0003] The present invention relates generally to medical devices and, more particularly, to sensors used for sensing physiological parameters of a patient.

[0004] 2. Description of the Related Art

[0005] This section is intended to introduce the reader to various aspects of art that may be related to various aspects of the present invention, which are described and/or claimed below. This discussion is believed to be helpful in providing the reader with background information to facilitate a better understanding of the various aspects of the present invention. Accordingly, it should be understood that these statements are to be read in this light, and not as admissions of prior art.

[0006] In the field of medicine, doctors often desire to monitor certain physiological characteristics of their patients. Accordingly, a wide variety of devices have been developed for monitoring physiological characteristics. Such devices provide doctors and other healthcare personnel with the information they need to provide the best possible healthcare for their patients. As a result, such monitoring devices have become an indispensable part of modern medicine.

[0007] One technique for monitoring certain physiological characteristics of a patient is commonly referred to as pulse oximetry, and the devices built based upon pulse oximetry techniques are commonly referred to as pulse oximeters. Pulse oximetry may be used to measure various blood flow characteristics, such as the blood-oxygen saturation of hemoglobin in arterial blood, the volume of individual blood pulsations supplying the tissue, and/or the rate of blood pulsations corresponding to each heartbeat of a patient.

[0008] Pulse oximeters typically utilize a non-invasive sensor that is placed on or against a patient's tissue that is well perfused with blood, such as a patient's finger, toe, forehead or earlobe. The pulse oximeter sensor emits light and photoelectrically senses the absorption and/or scattering of the light after passage through the perfused tissue. The data collected by the sensor may then be used to calculate one or more of the above physiological characteristics based upon the absorption or scattering of the light. More specifically, the emitted light is typically selected to be of one or more wavelengths that are absorbed or scattered in an amount related to the presence of oxygenated versus de-oxygenated hemoglobin in the blood. The amount of light absorbed and/or scattered may then be used to estimate the amount of the oxygen in the tissue using various algorithms.

[0009] In many instances, it may be desirable to employ, for cost and/or convenience, a pulse oximeter sensor that is secured with adhesives and is reusable. To facilitate this requirement, pulse oximeters may be assembled by wrapping a sensor in a flexible material. The wrapped sensor may then be secured to a cover material that is used to affix the wrapped sensor to the patient. Finally a packaging film may be applied over the adhesive and cover materials to protect the adhesive portion prior to the application of the sensor to the patient.

[0010] Such adhesive and reusable sensors, however, may be subject to stresses during unpackaging, application, and use. For example, when the film covering of an oximetry sensor, such as a neonate sensor, is removed before applica-

tion, the force of pulling away the film from the adhesive may cause stresses in the flexible material that cause the flexible material to tear. Tears in the flexible wrapping material may expose portions of the pulse oximeter sensor's circuitry and decrease the sensor's performance. These tears may be more common in corners of the flexible material where the stresses of pulling on the sensor are at their highest. As a further example, after the sensor is attached to the patient, stresses due to movement of the patient or the sensor may also lead to tears in the flexible material.

[0011] Also, it is desirable that the pulse oximeter sensor be assembled in a manner that eliminates exposure of the sensor's circuitry. Exposure of the sensor circuitry may lead to apprehension by the end user, and exposed circuitry may be susceptible to external sources of interference that may decrease the performance of the sensor. Therefore, the reusable sensor should be assembled in a manner that provides for complete enclosure of the pulse oximeter's circuitry. For example, when a pulse oximeter is assembled, the flexible material wrapped around the sensor should cover all portions of the pulse oximeter sensor. More specifically, when the flexible material is wrapped around the sensor, corner regions should not be void of material due to folds into adjacent areas.

SUMMARY

[0012] Certain aspects commensurate in scope with the originally claimed invention are set forth below. It should be understood that these aspects are presented merely to provide the reader with a brief summary of certain forms the invention might take and that these aspects are not intended to limit the scope of the invention. Indeed, the invention may encompass a variety of aspects that may not be set forth below.

[0013] In accordance with one aspect of the present invention, there is provided a sensor enclosure assembly, comprising: a substrate, comprising: a plurality of fastening flaps; and a reinforcing flap, wherein the fastening flaps are folded about primary fold lines, wherein the primary fold lines, or their projections, intersect to form a corner, and wherein the reinforcing flap spans a region near the corner not covered by the folded fastening flaps when the reinforcing flap is folded.

[0014] In accordance with another aspect of the present invention, there is provided a sensor assembly, comprising: a sensor; and a sensor enclosure assembly, comprising: a substrate, comprising: a plurality of fastening flaps; and a reinforcing flap, wherein the fastening flaps are folded about primary fold lines, wherein the primary fold lines, or their projections, intersect to form a corner, and wherein the reinforcing flap spans a region near the corner not covered by the folded fastening flaps when the reinforcing flap is folded.

[0015] In accordance with yet another aspect of the present invention, there is provided a method of manufacturing a sensor assembly, the method comprising: affixing a sensor to a sensor enclosure, wherein the sensor enclosure comprises: fastening flaps; and at least one reinforcing flap; folding the fastening flaps about a sensor; and folding the reinforcing flap about the sensor.

BRIEF DESCRIPTION OF THE DRAWINGS

[0016] Advantages of the invention may become apparent upon reading the following detailed description and upon reference to the drawings in which:

[0017] FIG. 1 illustrates a patient monitoring system coupled to a multi-parameter patient monitor and a sensor, in accordance with aspects of the present technique;

[0018] FIG. 2 illustrates a patient sensor assembly in accordance with aspects of the present technique;

[0019] FIG. 3 illustrates a flexible wrap in accordance with aspects of the prior art;

[0020] FIG. 4 illustrates a sensor assembly wherein the flexible wrap is folded about the sensor, and gap region remains that exposes sensor circuitry in accordance with aspects of the prior art;

[0021] FIG. 5 illustrates a modified flexible wrap in accordance with aspects of the present technique;

[0022] FIG. 6 depicts a flowchart of a method for cutting and assembling a modified flexible wrap about a sensor;

[0023] FIG. 7A-7G illustrates a sequence of folding the modified flexible wrap to enclose a sensor, in accordance with aspects of the present technique.

DETAILED DESCRIPTION OF SPECIFIC EMBODIMENTS

[0024] One or more specific embodiments of the present invention will be described below. In an effort to provide a concise description of these embodiments, not all features of an actual implementation are described in the specification. It should be appreciated that in the development of any such actual implementation, as in any engineering or design project, numerous implementation-specific decisions must be made to achieve the developers' specific goals, such as compliance with system-related and business-related constraints, which may vary from one implementation to another. Moreover, it should be appreciated that such a development effort might be complex and time consuming, but would nevertheless be a routine undertaking of design, fabrication, and manufacture for those of ordinary skill having the benefit of this disclosure.

[0025] It is desirable to provide a comfortable and reusable patient sensor, such as for use in pulse oximetry or other applications utilizing spectrophotometry, that does not expose portions of the sensor's circuitry and that is resistant to tearing. In accordance with some aspects of the present technique, a reusable patient sensor is provided that is wrapped in a flexible material that prevents exposure of the sensor and that is resistant to tearing. The flexible material may include an additional flap of material that prevents exposure of the sensor circuitry and which may provide added strength to resist tearing of the flexible material.

[0026] Prior to discussing such exemplary sensors in detail, it should be appreciated that such sensors are typically designed for use with a patient monitoring system. For example, referring now to FIG. 1, a sensor 2 according to an exemplary embodiment may be used in conjunction with a patient monitor 4. In the depicted embodiment, a cable 6 connects the sensor 2 to the patient monitor 4. As will be appreciated by those of ordinary skill in the art, the sensor 2 and/or the cable 6 may include or incorporate one or more integrated circuit devices or electrical devices, such as a memory, processor chip, or resistor, that may facilitate or enhance communication between the sensor 2 and the patient monitor 4. Likewise the cable 6 may be an adaptor cable, with or without an integrated circuit or electrical device, for facilitating communication between the sensor 2 and various types of monitors, including older or newer versions of the patient monitor 4 or other physiological monitors. In other embodi-

ments, the sensor 2 and the patient monitor 4 may communicate via wireless means, such as using radio, infrared, or optical signals. In such embodiments, a transmission device (not shown) may be connected to the sensor 2 to facilitate wireless transmission between the sensor 2 and the patient monitor 4. As will be appreciated by those of ordinary skill in the art, the cable 6 (or corresponding wireless transmissions) are typically used to transmit control or timing signals from the monitor 4 to the sensor 2 and/or to transmit acquired data from the sensor 2 to the monitor 4. In some embodiments, however, the cable 6 may be an optical fiber that allows optical signals to be conducted between the monitor 4 and the sensor 2.

[0027] In one embodiment, the patient monitor 4 may be a suitable pulse oximeter, such as those available from Nellcor Puritan Bennett Inc. In other embodiments, the patient monitor 4 may be a monitor suitable for measuring tissue water fractions, or other body fluid related metrics, using spectrophotometric or other techniques. Furthermore, the monitor 4 may be a multi-purpose monitor suitable for performing pulse oximetry and measurement of tissue water fraction, or other combinations of physiological and/or biochemical monitoring processes, using data acquired via the sensor 2. Furthermore, to upgrade conventional monitoring functions provided by the monitor 4 to provide additional functions, the patient monitor 4 may be coupled to a multi-parameter patient monitor 8 via a cable 10 connected to a sensor input port and/or via a cable 12 connected to a digital communication port.

[0028] The sensor 2, depicted in FIG. 1, is an adhesive style sensor that is flexible to conform to the surface of a patient's skin. The sensor 2 includes an emitter 14 and a detector 16 which may be of any suitable type. For example, the emitter 14 may be one or more light emitting diodes adapted to transmit one or more wavelengths of light, such as in the red to infrared range, and the detector 16 may be a photodetector, such as a silicon photodiode package, selected to receive light in the range emitted from the emitter 14. In the depicted embodiment, the sensor 2 is coupled to a cable 6 that is responsible for transmitting electrical and/or optical signals to and from the emitter 14 and detector 16 of the sensor 2. The cable 6 may be permanently coupled to the sensor 2, or it may be removably coupled to the sensor 2—the latter alternative being more useful and cost efficient in situations where the sensor 2 is disposable.

[0029] The sensor 2 described above is generally configured for use as a "transmission type" sensor for use in spectrophotometric applications, though in some embodiments it may instead be configured for use as a "reflectance type sensor." Transmission type sensors include an emitter 14 and detector 16 that are typically placed on opposing sides of the sensor site. If the sensor site is a fingertip, for example, the sensor 2 is positioned over the patient's fingertip such that the emitter 14 and detector 16 lie on either side of the patient's nail bed. For example, the sensor 2 is positioned so that the emitter 14 is located on the patient's fingernail and the detector 16 is located opposite the emitter 14 on the patient's finger pad. During operation, the emitter 14 shines one or more wavelengths of light through the patient's fingertip, or other tissue, and the light received by the detector 16 is processed to determine various physiological characteristics of the patient.

[0030] Reflectance type sensors generally operate under the same general principles as transmittance type sensors. However, reflectance type sensors include an emitter and

detector that are typically placed on the same side of the sensor site. For example, a reflectance type sensor may be placed on a patient's fingertip such that the emitter and detector are positioned side-by-side. Reflectance type sensors detect light photons that are scattered back to the detector.

[0031] As described previously, the sensor 2 discussed herein may be configured for either transmission or reflectance type sensing. For simplicity, the exemplary embodiment of the sensor 2 described herein is adapted for use as a transmission-type sensor. As will be appreciated by those of ordinary skill in the art, however, such discussion is merely exemplary and is not intended to limit the scope of the present technique.

[0032] Referring now to FIG. 2, a sensor assembly 20 is depicted. As shown, the sensor assembly 20 is a neonate transmission type sensor. Such a neonate sensor may include, for example, pulse oximeter sensor circuitry 22, which is enclosed within a flexible wrap 24, and which is secured to a patient by a bandage 26. Generally, a pulse oximeter sensor is assembled by enclosing the sensor circuitry 22 within the flexible wrap 24. The flexible wrap 24 is generally formed from a substrate, such as a sheet of plastic, that is cut into a shape that provides for the substrate to enclose and conform to the shape of the sensor circuitry 22, as depicted in FIG. 3. To enable a single sheet of two-dimensional substrate to enclose all sides of the sensor circuitry 22, the substrate shape may contain a bottom 29, as well as primary flaps 30, 31, and 32 which may be folded over the sensor circuitry 22 to enclose the sensor circuitry 22. However, generally, this procedure may result in folds which do not cover all portions of the sensor circuitry or sensor cable. For example, as depicted by FIG. 4, the primary flaps 30, 31, and 32 of flexible wrap 24 may be folded leaving a gap region 33 that does not provide for coverage a the sensor cable 28 or sensor circuitry 22. This gap region 33 may allow exposure of the sensor circuitry 22 and of a sensor cable 28. Further, the absence of material in the gap region 33 promotes localized stresses that may result in increased instances of tearing in or near the gap region 33.

[0033] Referring now to FIG. 5, a modified flexible wrap 34 is depicted. In the depicted example, the modified flexible wrap 34 includes a reinforcing flap 36 that may be folded over the sensor circuitry 22 to cover the gap region 33 (see FIG. 4) and to increase the flexible wrap's 34 resistance to tearing. Such a reinforcing flap 36 may include a variety of shapes and locations. For example, the reinforcing flap 36 may be located in a region between two primary flaps 30 and 31 and formed by reinforcing cuts 38 and 39. In one embodiment, the reinforcing cuts 38 and 39 may be aligned at angle not substantially parallel to the primary fold lines 42 and 43 about which the primary flaps 30 and 31 are folded. By making reinforcing cuts 38 and 39 that are not substantially parallel to the primary fold lines 42 and 43, there may be provided additional material to be used in forming the primary flaps 30 and 31 adjacent to the reinforcing flap 36. For example, as depicted in FIG. 5, the reinforcing cuts 38 and 39 are made at an angles that generally dissect the angle of the corner 46 formed by the projections 44 and 45 of the primary fold lines 42 and 43. It should be noted that, the angle of the reinforcing cut 38 provides for additional material available for the primary flap 31. The reinforcing flap 36 may then be folded about reinforcing fold line A 48, which is formed between the ends of the reinforcing cuts 38 and 39 nearest the corner 46.

[0034] In one embodiment, relief cuts 40 and 41 may be made at the ends of the reinforcing cuts 38 and 39 wherein the

relief cuts 40 and 41 are not parallel to the reinforcing cuts 38 and 39. For example, as depicted in FIG. 5, the relief cuts 41 and 40 may be made from the ends of the reinforcing cuts 38 and 39 in a direction parallel to primary fold line 43. The relief cuts 40 and 41 provide for folding the reinforcing flap 36 in a multitude of angles without promoting tearing at the end of the reinforcing cuts 38 and 39 nearest the corner 46 or the relief cuts 40 and 41. For example, the relief cuts 40 and 41 provide for folding of the reinforcing flap 36 about multiple fold lines. As depicted, the reinforcing flap 36 may be folded about reinforcing fold line A 48, reinforcing fold line B 50, or reinforcing fold line C 52, or it may be folded at any angle between the reinforcing fold line B 50 and the reinforcing fold line C 52. As a person of ordinary skill in the art will appreciate, the length and angle of the reinforcing cuts 38 and 39 and the relief cuts 40 and 41 may be varied in number, length, angle, and shape to provide for the needs of various folding applications.

[0035] Turning now to FIG. 6, a flowchart of a method to assemble the flexible wrap 24 to the sensor circuitry 22 is depicted. First, a substrate of flexible wrap 24 may be provided (Block 64) from which the modified flexible wrap 24 may be shaped (Block 66). For example, a sheet of flexible wrap 24 may be provided and cut to shape of the modified flexible wrap 34, as depicted in FIG. 5. As will be appreciated by a person of ordinary skill in the art, the method of forming the modified flexible wrap 34 may be varied to accommodate various means of manufacture. For example, the flexible wrap 24 may include a single sheet of substrate cut to the shape of the modified flexible wrap 34, or the flexible wrap 24 may initially be formed in the shape of the modified flexible wrap 34, and require minimal or no modification. The sensor circuitry 22 may then be placed (Block 68) onto the bottom 29 of the modified flexible wrap 34. The primary folding flaps 30, 31 and 32 and reinforcing flap(s) 36 may be folded (Block 70) about the fold lines to enclose the sensor circuitry 22. For example, FIG. 7 depicts the method of manufacturing a pulse oximeter sensor by placing and wrapping sensor circuitry 22 in the modified flexible wrap 34. FIG. 7A depicts placing the sensor circuitry 22 on the bottom 29 of the modified flexible wrap 34. FIG. 7B depicts folding a top primary flap 56 about a top primary fold line 57. FIG. 7C depicts folding side primary flaps 58 about side primary fold lines 59. FIG. 7D depicts folding the primary flap 30 about the primary fold line 43. FIG. 7E depicts folding the reinforcing flap 36 about reinforcing fold line C 52. FIG. 7F depicts folding a lower primary flap 60 about a lower primary fold line 61. FIG. 7G depicts folding the primary flap 31 about a primary fold line 42. As will be appreciated by those ordinarily skilled in the art, the number and sequence of steps to enclose the sensor circuitry may vary to provide for various applications. For example, the sequence of folding the flaps as depicted in FIG. 7 may be varied in any sequence.

[0036] While the exemplary medical sensors 2 discussed herein are some examples of adhesive and disposable medical devices, other such devices are also contemplated and fall within the scope of the present disclosure. For example, other medical sensors and/or contacts applied externally to a patient may be advantageously applied using a modified flexible enclosure as discussed herein. Examples of such sensors or contacts may include glucose monitors or other sensors or contacts that are generally held adjacent to the skin of a patient such that a conformable and comfortable fit is desired. Similarly, and as noted above, devices for measuring tissue

water fraction or other body fluid related metrics may utilize a sensor as described herein. Likewise, other spectrophotometric applications where a probe is attached to a patient may utilize a sensor as described herein.

[0037] While the invention may be susceptible to various modifications and alternative forms, specific embodiments have been shown by way of example in the drawings and have been described in detail herein. However, it should be understood that the invention is not intended to be limited to the particular forms disclosed. Rather, the invention is to cover all modifications, equivalents, and alternatives falling within the spirit and scope of the invention as defined by the following appended claims. Indeed, the present techniques may not only be applied to transmission type sensors for use in pulse oximetry, but also to retroflective and other sensor designs as well. Likewise, the present techniques are not limited to use on fingers and toes but may also be applied to placement on other body parts such as in embodiments configured for use on the ears or nose.

What is claimed is:

1. A sensor enclosure assembly capable of being wrapped about a sensor to protectively cover the sensor and strengthen a bandage assembly incorporating the sensor, comprising:

a pliable substrate, comprising:

a bottom bounded by primary fold lines;

a plurality of fastening flaps extending from the bottom and capable of folding over at least a portion of the bottom along the primary fold lines, wherein the primary fold lines or their projections intersect to form a corner; and

a reinforcing flap, wherein the reinforcing flap spans a region near the corner not covered by the folded fastening flaps when the reinforcing flap is folded about a reinforcing flap fold line of the substrate.

2. The sensor enclosure assembly of claim 1, wherein a first edge of the reinforcing flap extending from the bottom is adjacent a first fastening flap, and a second edge of the reinforcing flap extending from the bottom is adjacent a second fastening flap.

3. The sensor enclosure assembly of claim 2, wherein the reinforcing flap fold line is formed by a span between an intersection of the first edge with the bottom and an intersection of the second edge with the bottom.

4. The sensor enclosure assembly of claim 2, wherein the first edge extends in a direction substantially parallel to at least one of the primary fold lines.

5. The sensor enclosure assembly of claim 1, wherein the bottom comprises an L-shape.

6. The sensor enclosure assembly of claim 1, wherein a first flap of the plurality of fastening flaps folds over a first portion of a cable when the sensor is arranged on the bottom and coupled with the cable, and the reinforcing flap covers a second portion of the cable between the first flap and a second flap of the plurality of fastening flaps.

7. A sensor assembly, comprising:

a sensor; and

a sensor enclosure assembly wrapped about the sensor, comprising:

a substrate, comprising:

a bottom;

a plurality of fastening flaps extending from the bottom, wherein the plurality of fastening flaps fold about primary fold lines along the bottom and over

the sensor, wherein the sensor is positioned adjacent the bottom and the primary fold lines or their projections intersect to form a corner; and
a reinforcing flap extending from the bottom, wherein the reinforcing flap spans a region near the corner not covered by the folded fastening flaps when the reinforcing flap is folded.

8. The sensor assembly of claim 7, wherein a first edge of the reinforcing flap extending from the bottom is adjacent a first fastening flap, and a second edge of the reinforcing flap extending from the bottom is adjacent a second fastening flap.

9. The sensor assembly of claim 8, wherein the reinforcing flap is folded along a reinforcing flap fold line that is formed by a span between an intersection of the first edge with the bottom and an intersection of the second edge with the bottom.

10. The sensor assembly of claim 7, wherein the reinforcing flap covers a portion of a cable communicatively coupled to the sensor when the reinforcing flap is folded.

11. The sensor assembly of claim 10, wherein the reinforcing flap directly contacts the cable.

12. The sensor assembly of claim 7, wherein the bottom is substantially L-shaped and a portion of the bottom is adjacent a cable communicatively coupled with the sensor.

13. The sensor assembly of claim 7, wherein the reinforcing flap covers exposed portions of the sensor when folded on top of at least one of the plurality of fastening flaps that was previously folded.

14. The sensor assembly of claim 7, comprising a material affixed to the sensor enclosure, wherein the material provides for attachment of the sensor assembly to a surface.

15. A method of manufacturing a sensor assembly, the method comprising:

affixing a sensor to a sensor enclosure, wherein the sensor enclosure comprises:

a bottom;

fastening flaps extending from the bottom; and

at least one reinforcing flap;

folding the fastening flaps about a sensor; and

folding the reinforcing flap about the sensor.

16. The method of claim 15, wherein the sensor is a pulse oximeter sensor.

17. The method of claim 15, comprising folding the reinforcing flap about the sensor such that the reinforcing flap covers an area not covered by at least one of the fastening flaps that has been folded.

18. The method of claim 15, comprising affixing material to the sensor enclosure to provide for attachment of the sensor assembly to a surface.

19. The method of claim 15, wherein folding the reinforcing flap about the sensor comprises folding the reinforcing flap about a reinforcing fold line, wherein the reinforcing fold line is a span between an intersection of a first edge of the reinforcing flap extending from the bottom and a second edge of the reinforcing flap extending from the bottom such that the reinforcing fold line is at an angle with the length of the bottom.

20. The method of claim 19, wherein the first edge of the reinforcing flap is adjacent a first fastening flap, and the second edge of the reinforcing flap is adjacent a second fastening flap.

* * * * *

专利名称(译)	灵活的医疗传感器外壳		
公开(公告)号	US20090270691A1	公开(公告)日	2009-10-29
申请号	US12/491940	申请日	2009-06-25
[标]申请(专利权)人(译)	内尔科尔普里坦贝内特公司		
申请(专利权)人(译)	NELLCOR PURITAN BENNETT LLC		
当前申请(专利权)人(译)	COVIDIEN LP		
[标]发明人	ARIZAGA BALLESTEROS ADOLFO		
发明人	ARIZAGA BALLESTEROS, ADOLFO		
IPC分类号	A61B5/00		
CPC分类号	A61B5/02444 A61B2562/164 A61B5/14552		
其他公开文献	US8315685		
外部链接	Espacenet USPTO		

摘要(译)

提供了一种传感器，其包括围绕传感器折叠的柔性包裹外壳。柔性包裹物包括主翼片和至少一个加强翼片。加强翼片可用于封闭未被初级包裹物包围的传感器区域和/或可用于提供外壳的加强以防止柔性包裹外壳的撕裂。传感器可以放置在患者的手指，脚趾，耳朵等上，以获得脉搏血氧测定法或其他生理测量值。

