



(19) **United States**
(12) **Patent Application Publication**
Clark et al.

(10) **Pub. No.: US 2007/0055116 A1**
(43) **Pub. Date: Mar. 8, 2007**

(54) **MOBILE CLINICAL WORKSTATION**

is a continuation of application No. 10/171,582, filed on Jun. 13, 2002, now Pat. No. 6,721,178, which is a continuation of application No. 09/397,817, filed on Sep. 17, 1999, now Pat. No. 6,493,220.

(76) Inventors: **Richard A. Clark**, Atlanta, GA (US);
Michael R. Jacobs, Las Vegas, NV (US);
Steven B. Flemig, Woodstock, GA (US);
Fouad Abu-Akel, Duluth, GA (US);
Darin Janoschka, Roswell, GA (US);
Keith Washington, Alpharetta, GA (US)

Publication Classification

(51) **Int. Cl.**
A61B 5/00 (2006.01)
(52) **U.S. Cl.** **600/300**

Correspondence Address:
SUTHERLAND ASBILL & BRENNAN LLP
999 PEACHTREE STREET, N.E.
ATLANTA, GA 30309 (US)

(57) **ABSTRACT**

(21) Appl. No.: **11/358,164**
(22) Filed: **Feb. 21, 2006**

A mobile workstation for use with a computer network. The mobile workstation may include a medical monitoring device, a radio transceiver in communication with the medical monitoring device operable for receiving and sending data to the computer network, a display screen, and a wheeled chassis for mounting the medical monitoring device, the radio transceiver and the display screen.

Related U.S. Application Data

(63) Continuation-in-part of application No. 10/783,333, filed on Feb. 20, 2004, now Pat. No. 7,009,840, which

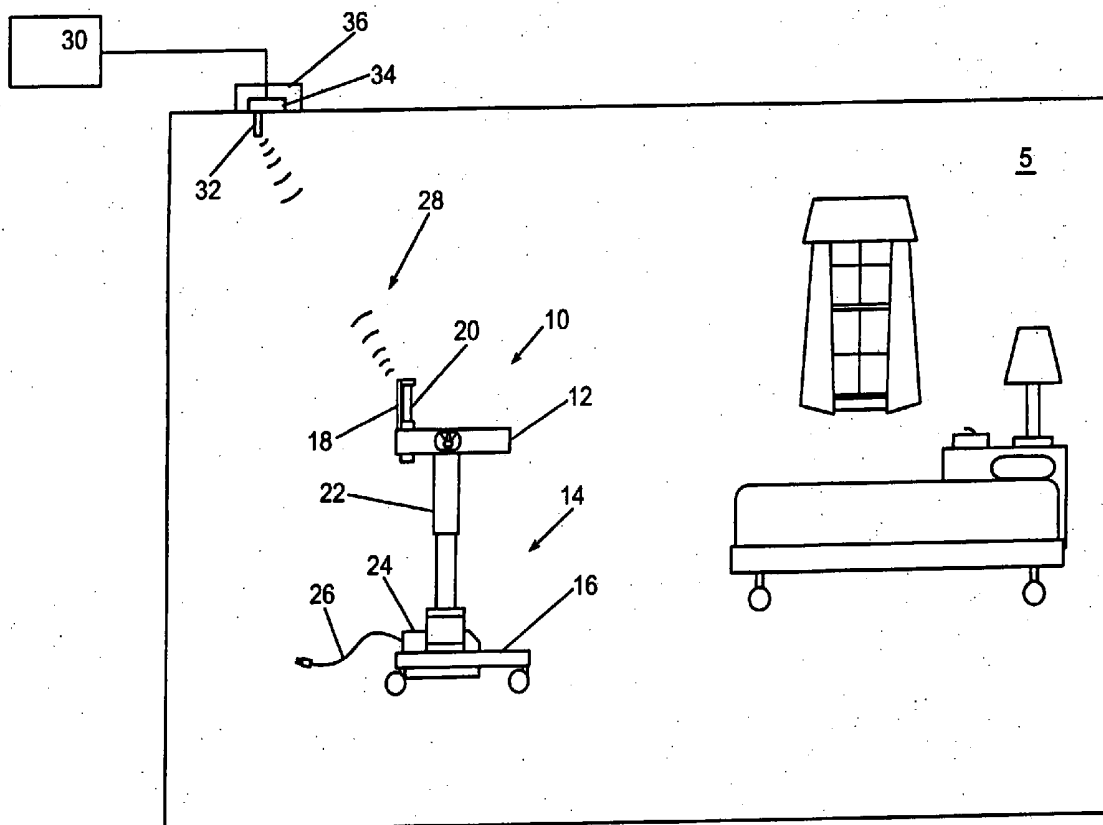

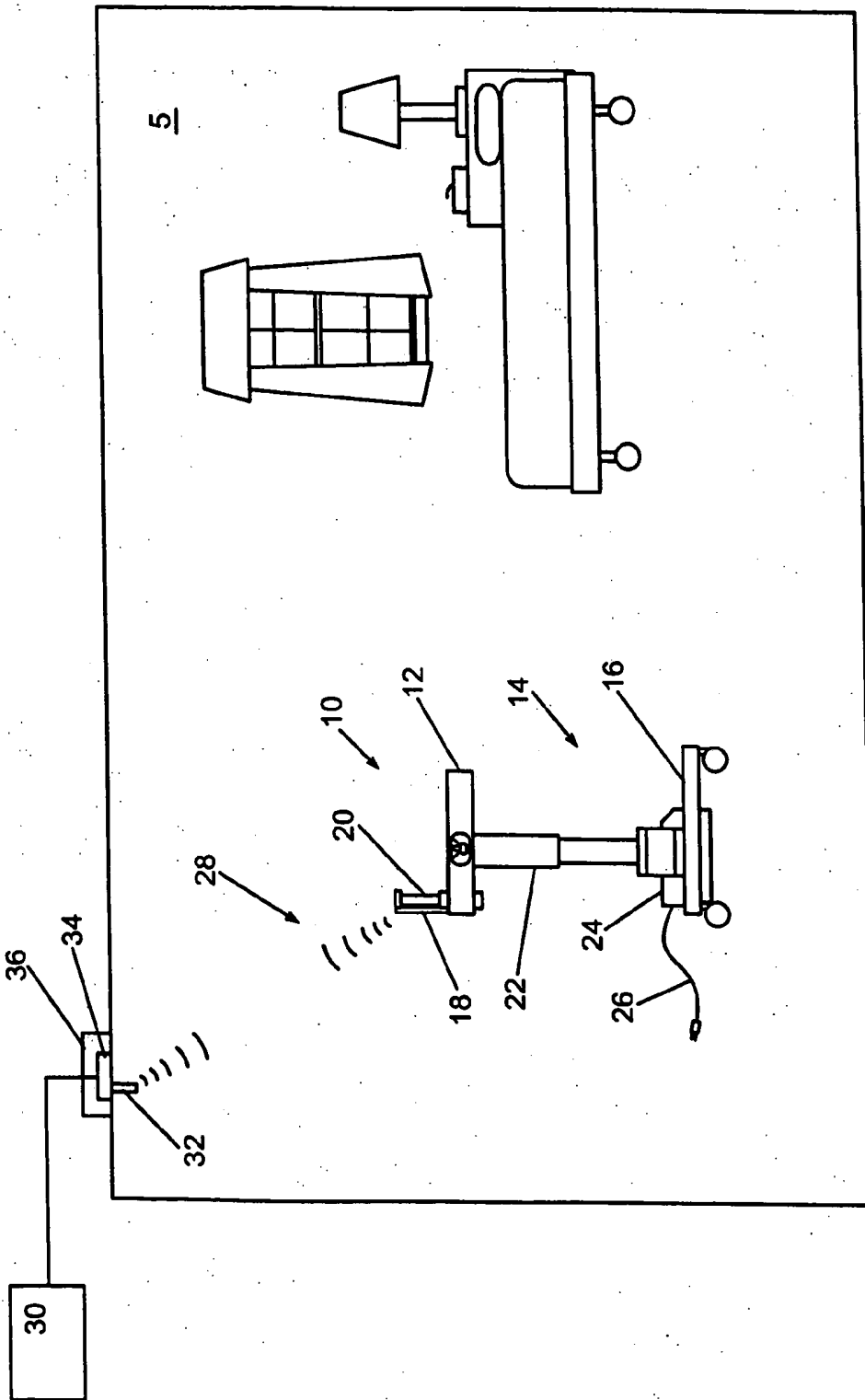

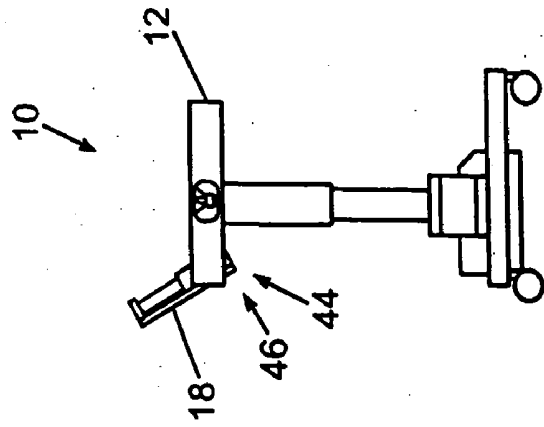

Fig. 20

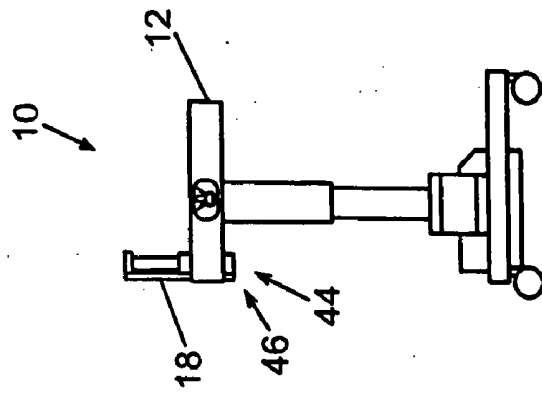

Fig. 21

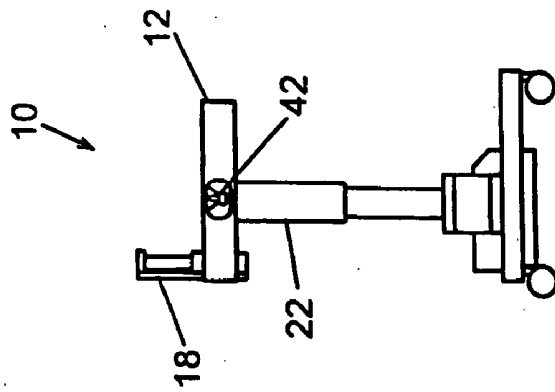

Fig. 22

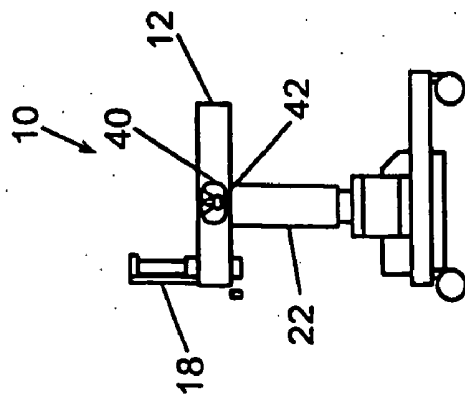

Fig. 23

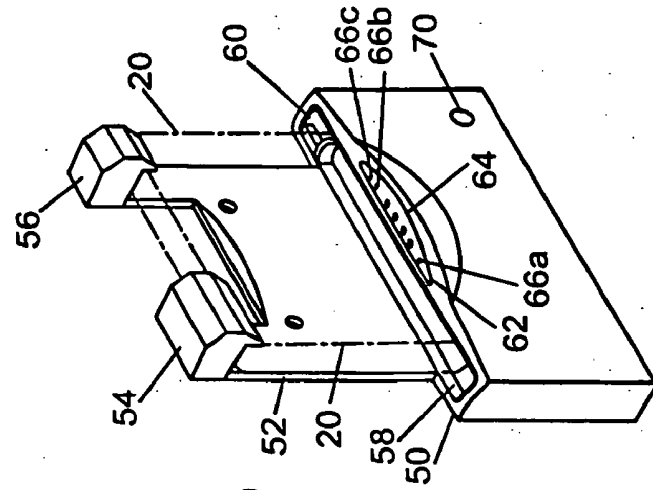

Fig. 3A

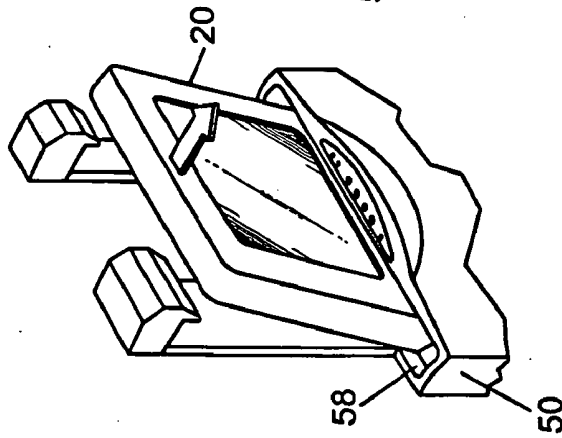

Fig. 3B

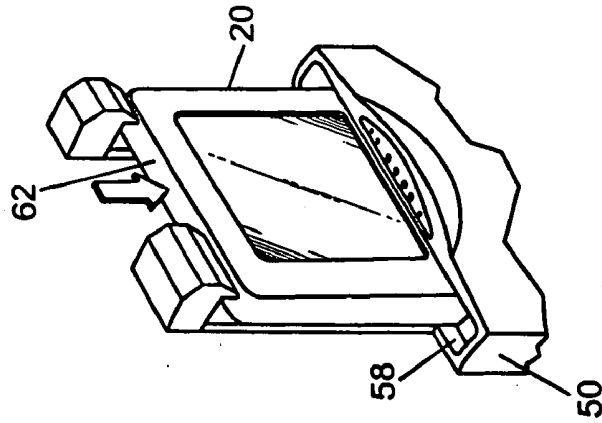

Fig. 3C

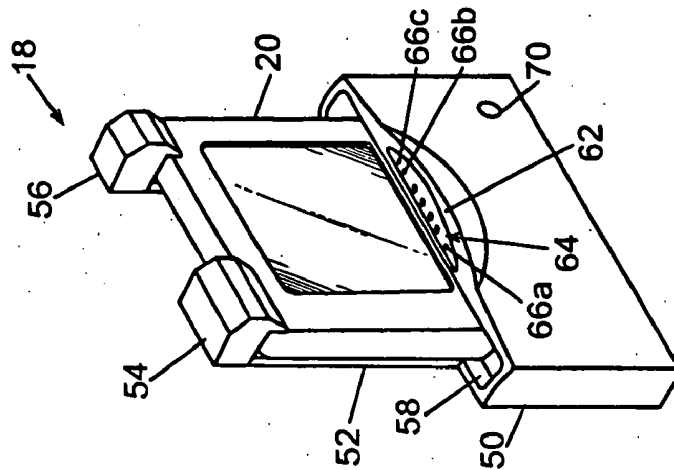

Fig. 3D

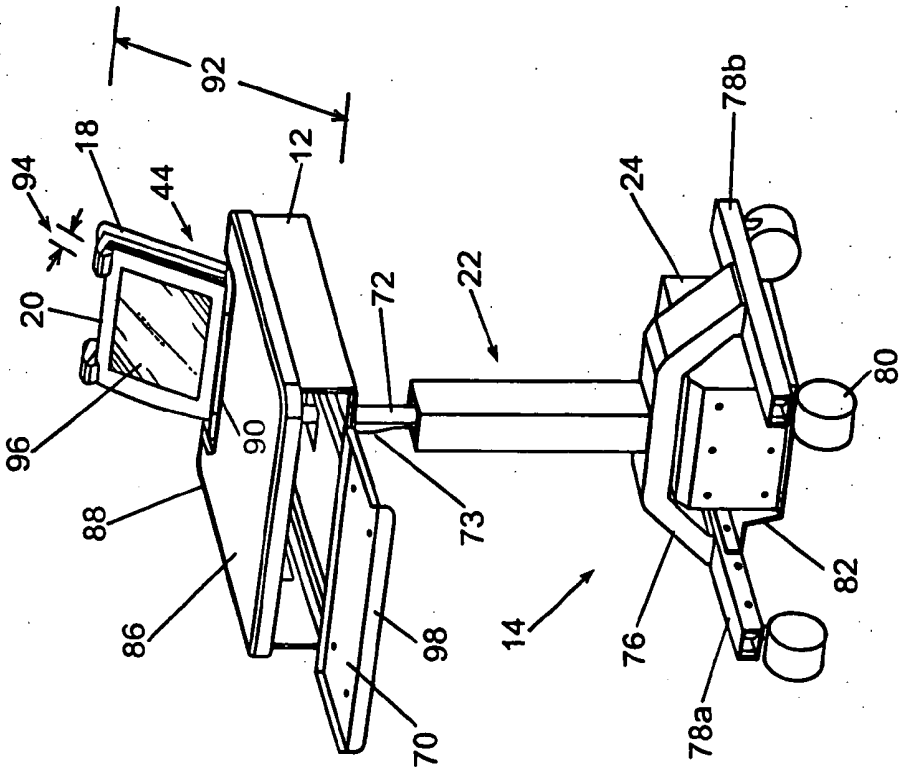

Fig. 4B

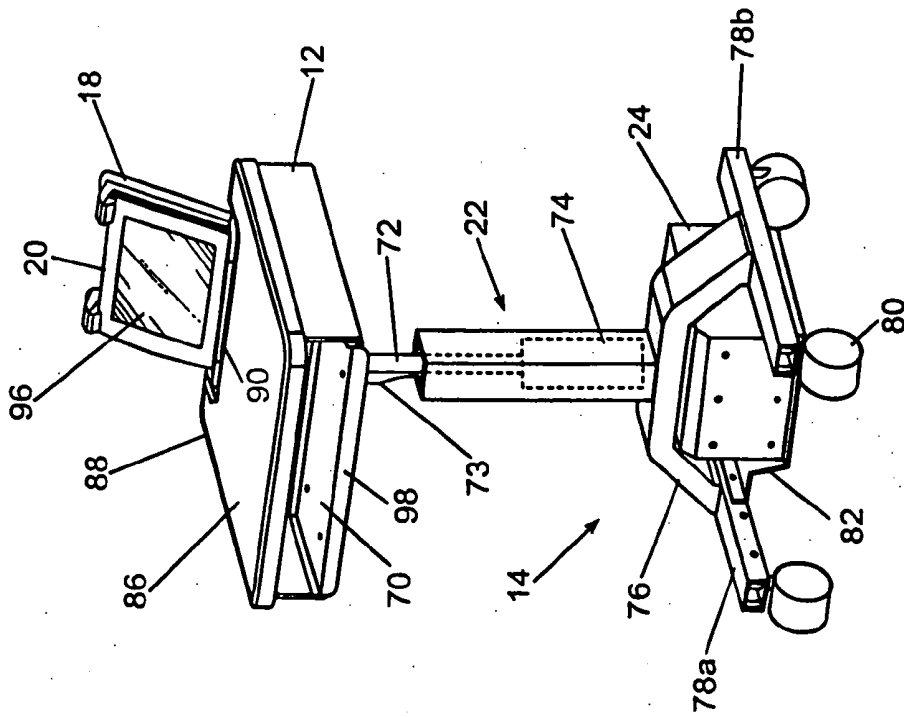

Fig. 4A

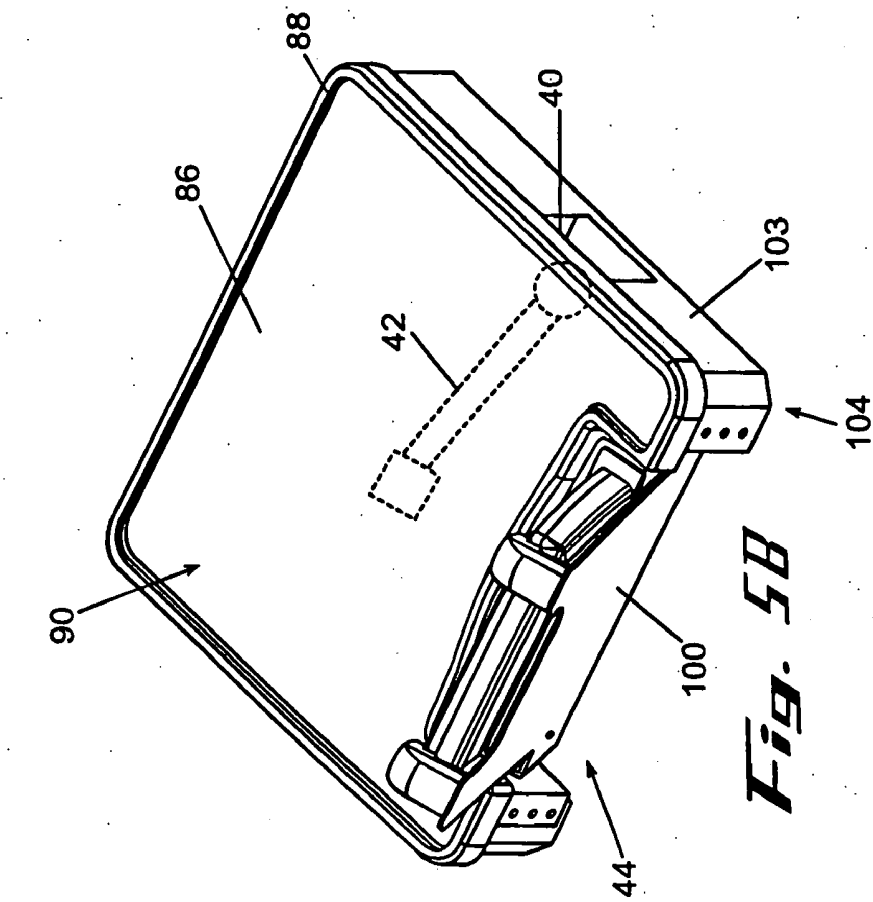

Fig. 5A

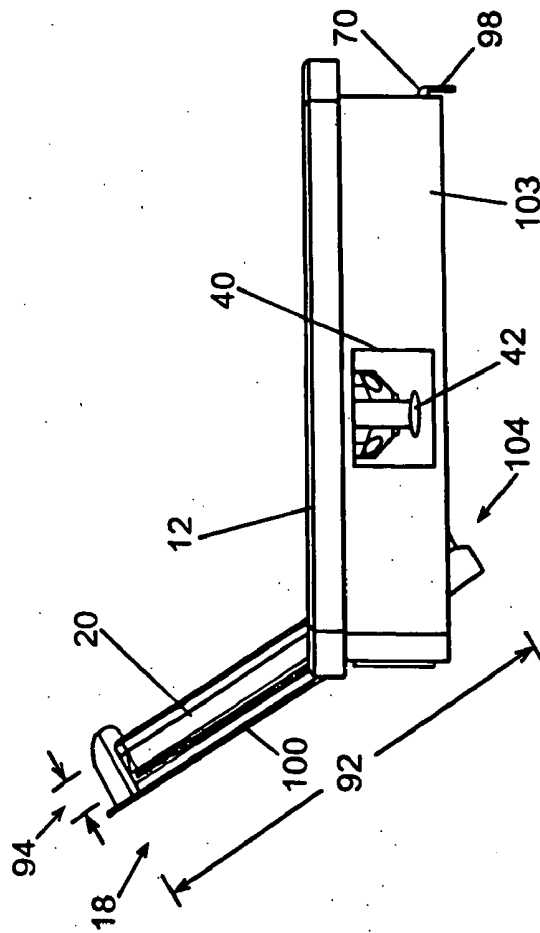

Fig. 5B

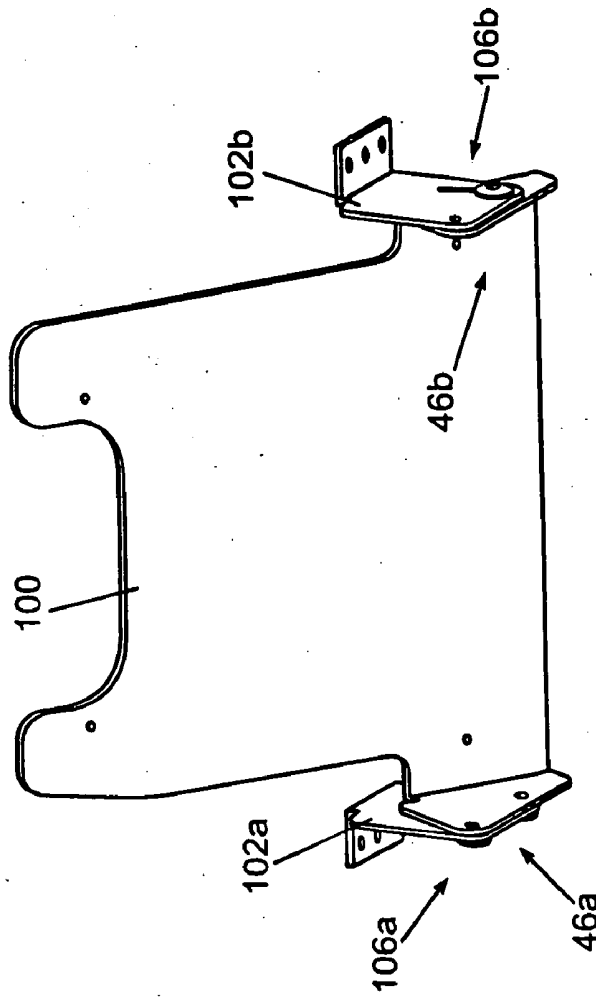

Fig. 6B

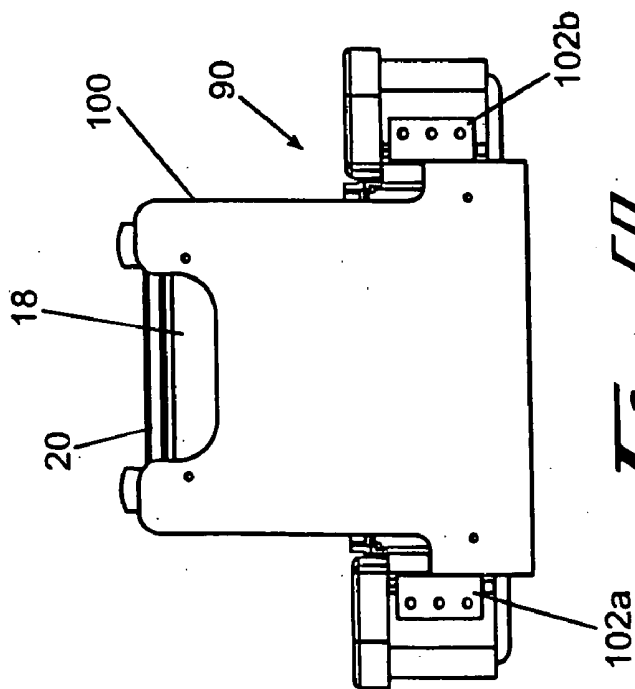

Fig. 6A

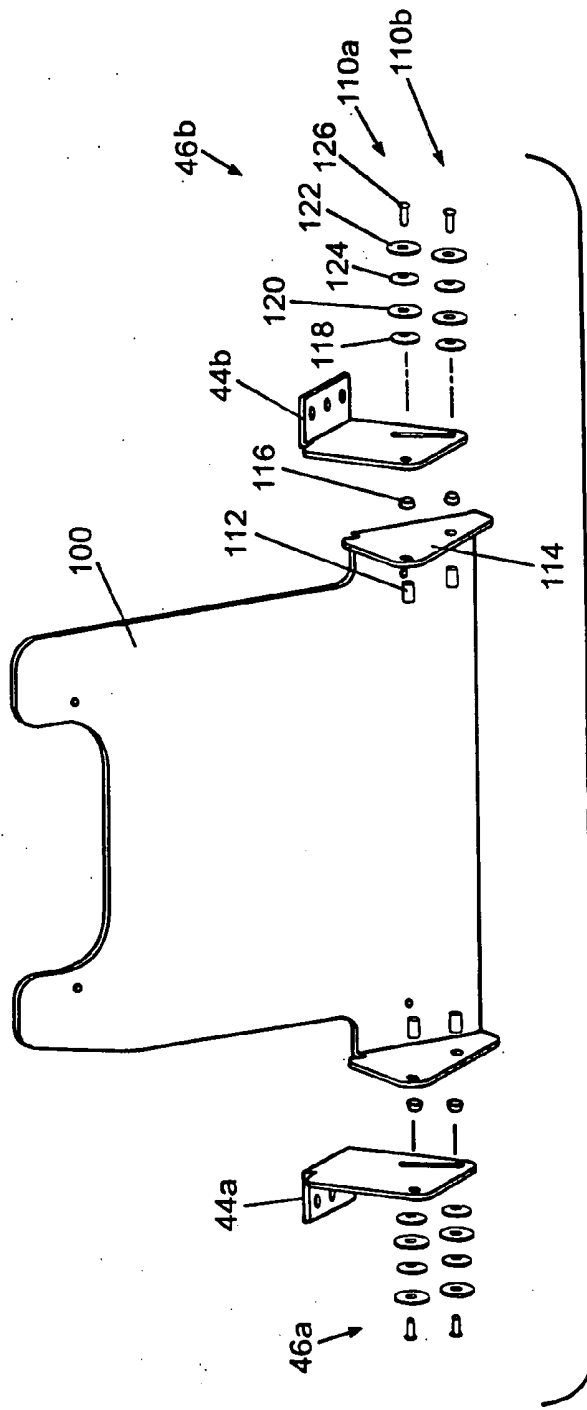

Fig. 7A

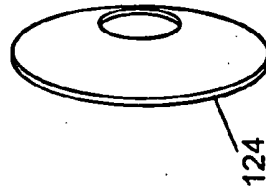

Fig. 7B

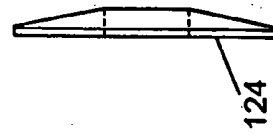

Fig. 7C

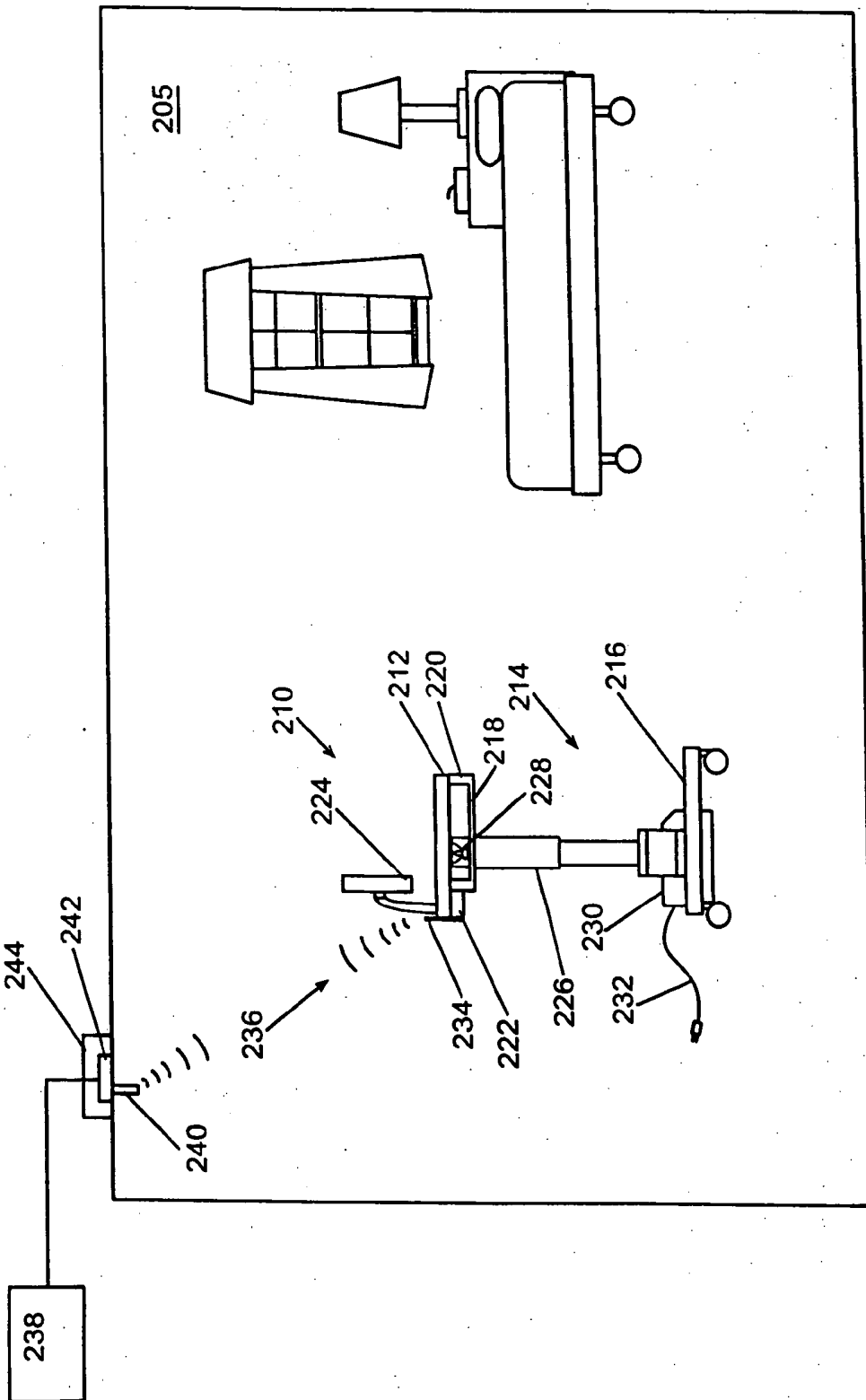

Fig. 8

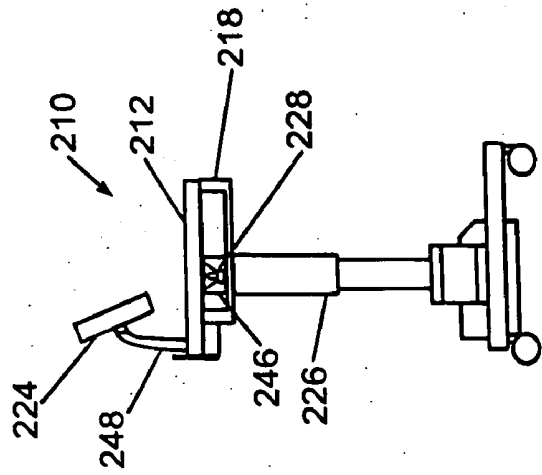

Fig. 9A

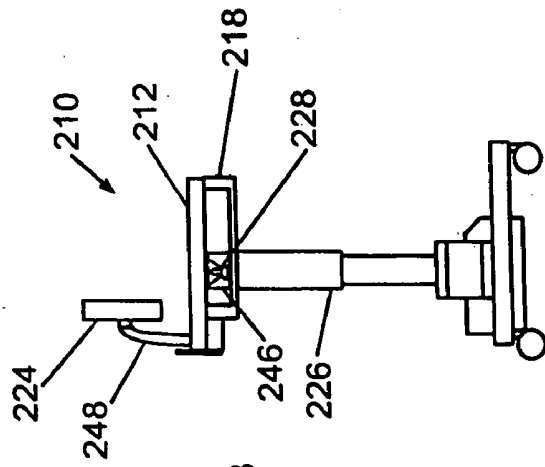

Fig. 9B

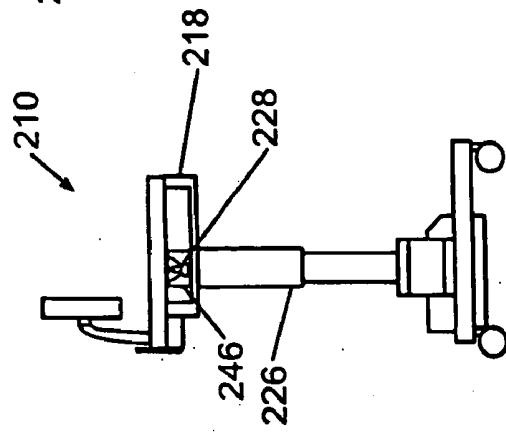

Fig. 9C

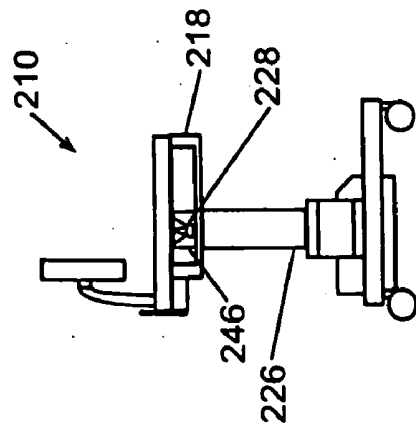

Fig. 9D

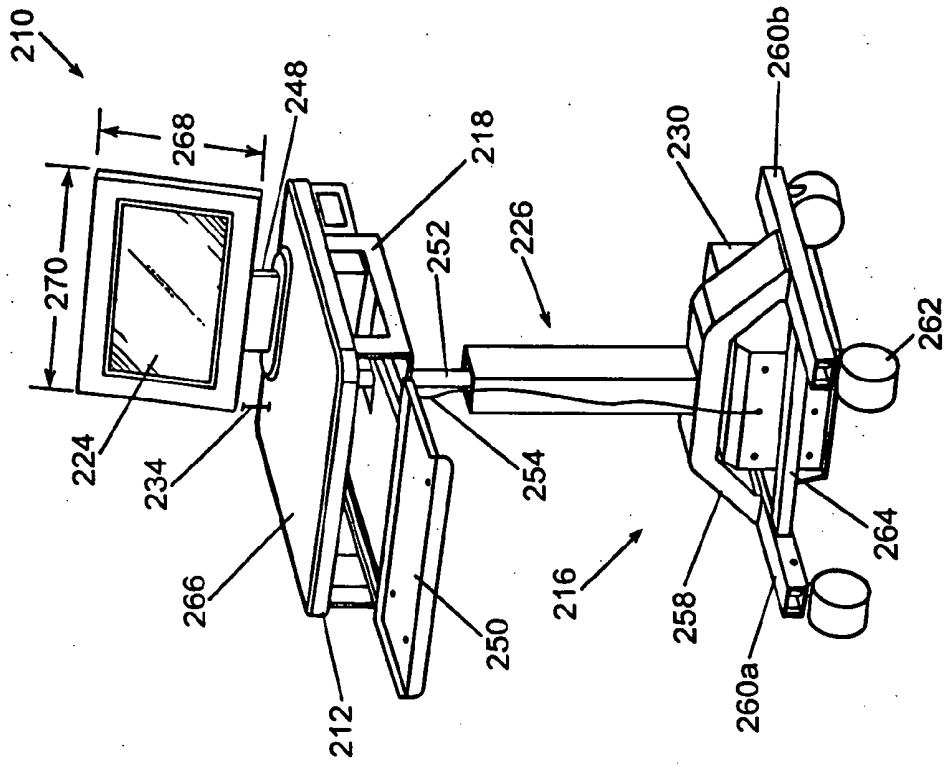

Fig. 10B

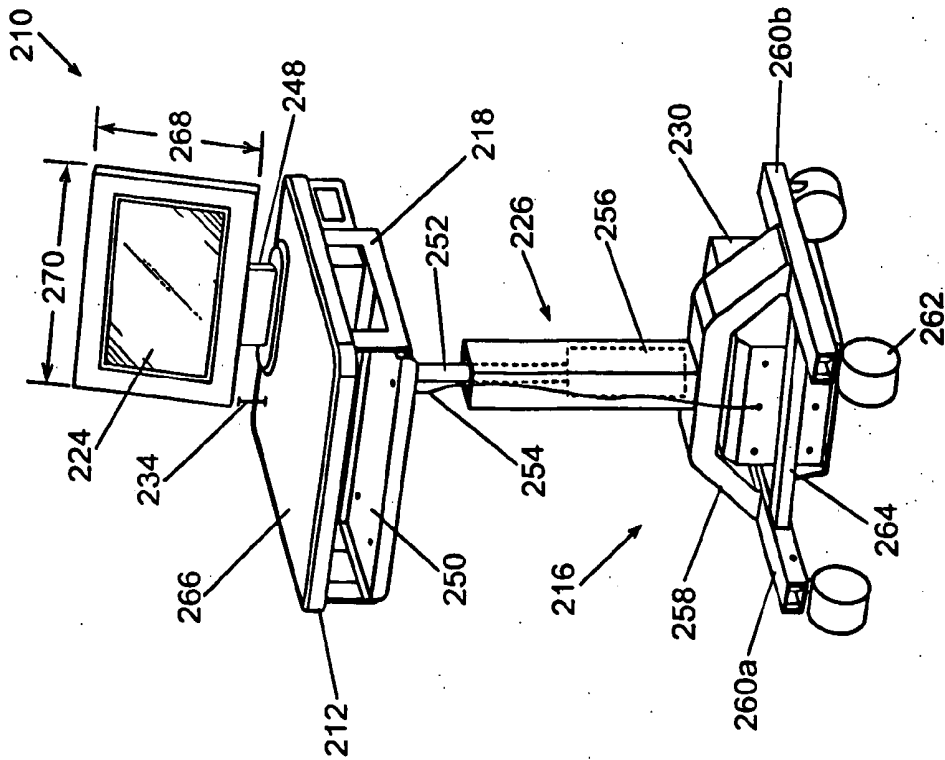

Fig. 10A

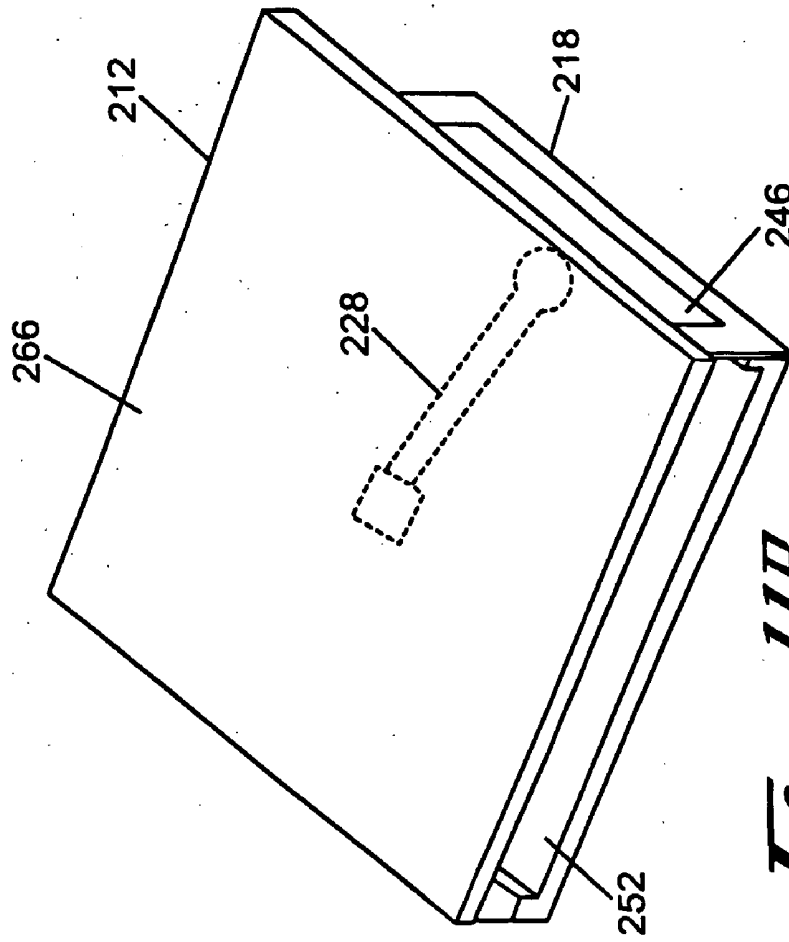

Fig. 11B

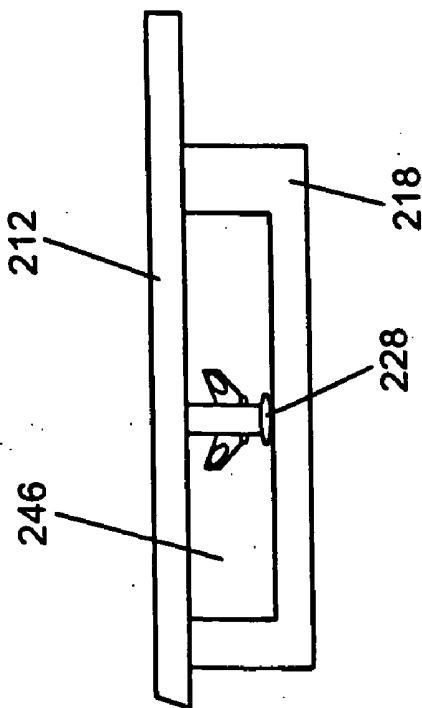

Fig. 11A

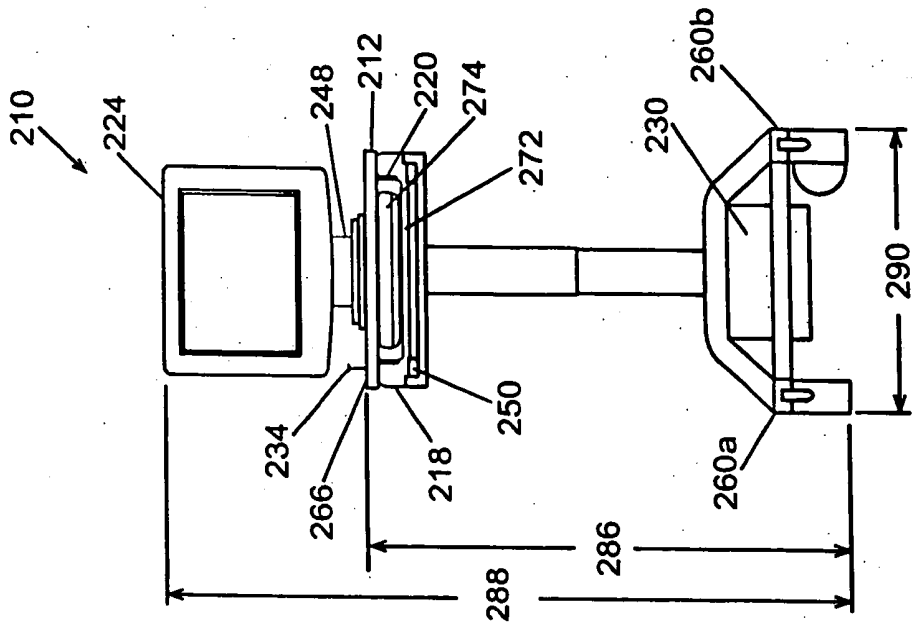

Fig. 12C

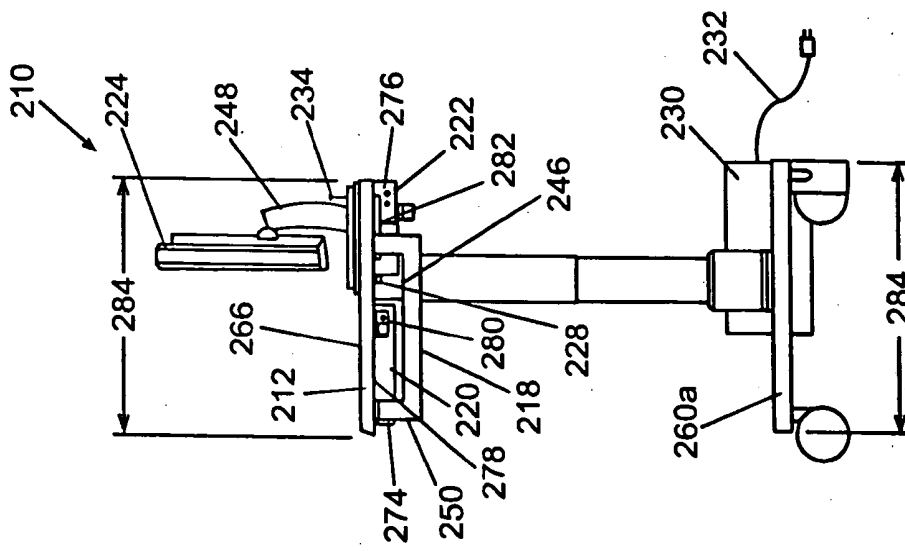

Fig. 12B

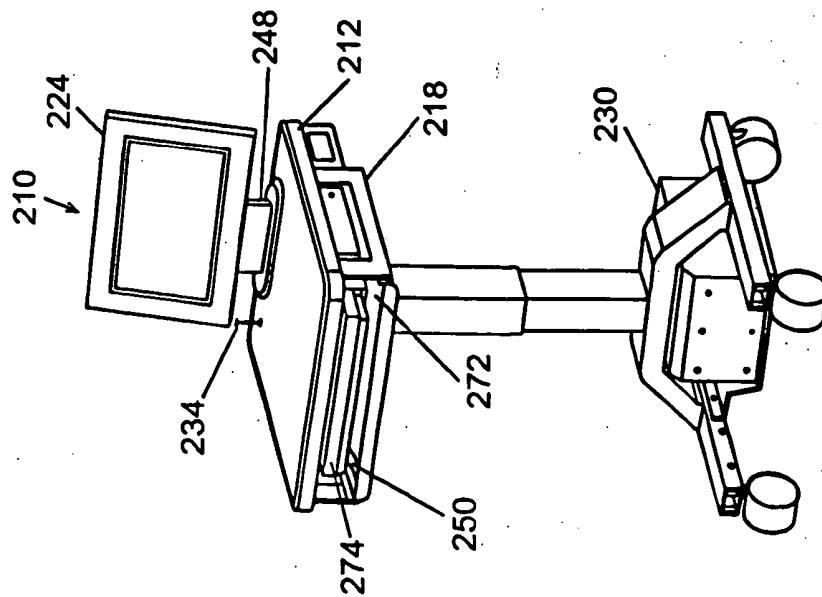

Fig. 12A

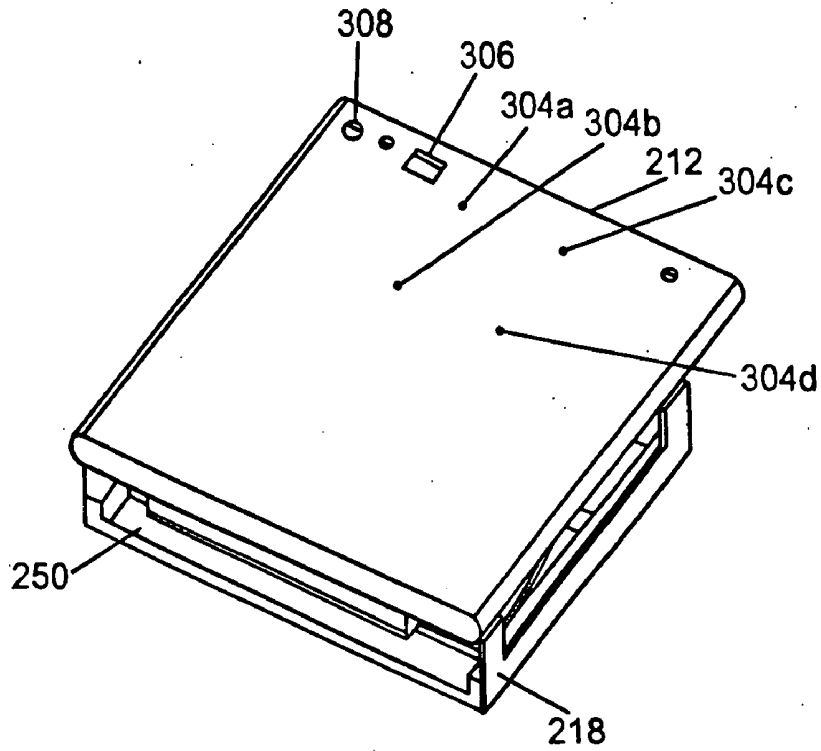

Fig. 13A

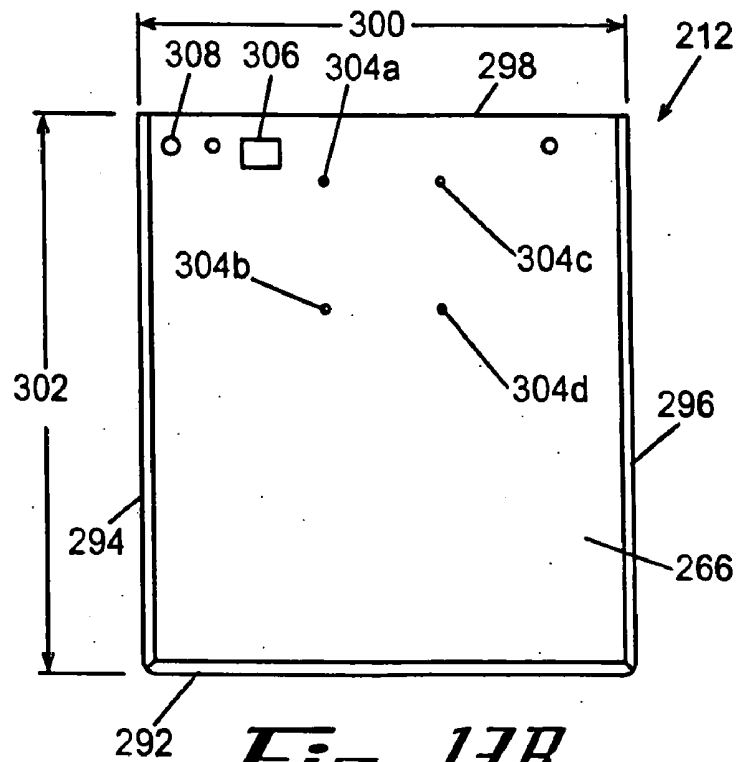

Fig. 13B

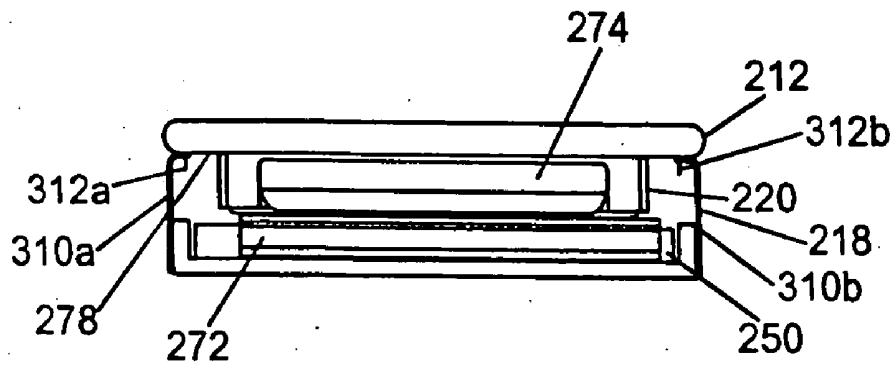

Fig. 13C

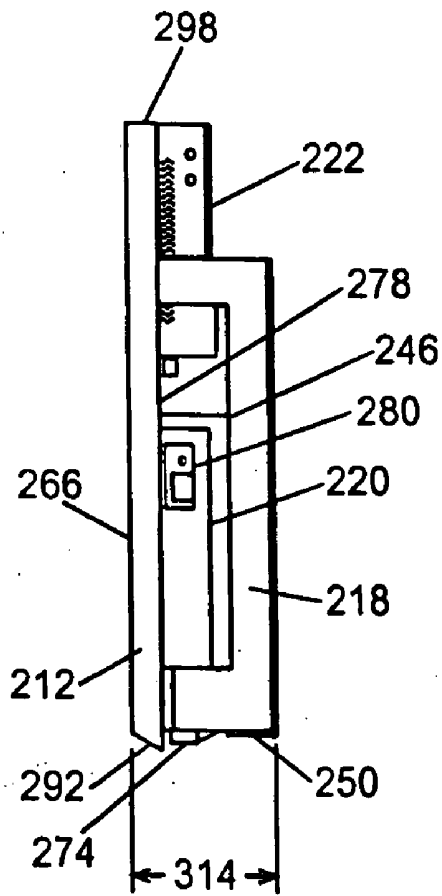

Fig. 13D

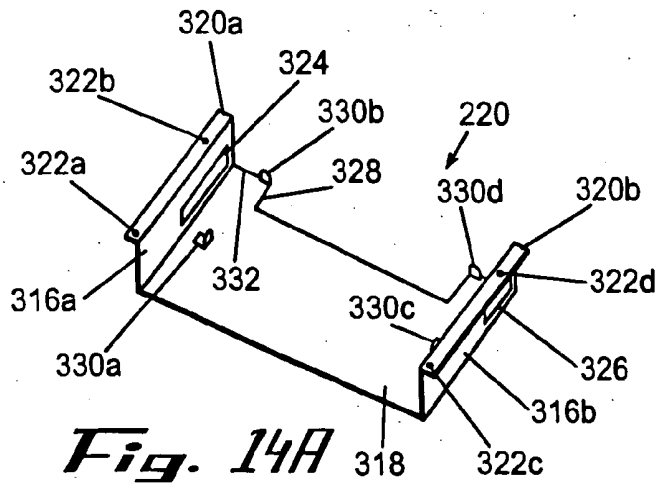

Fig. 14A

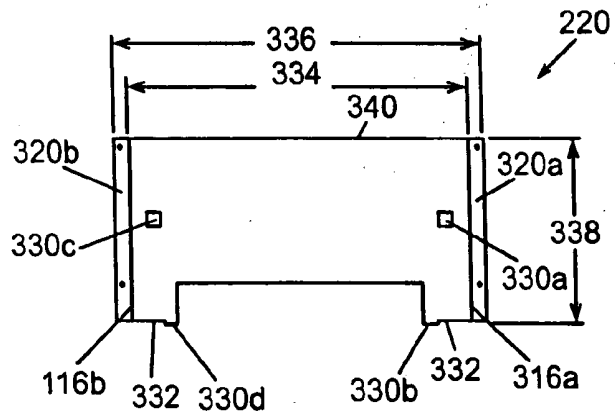

Fig. 14B

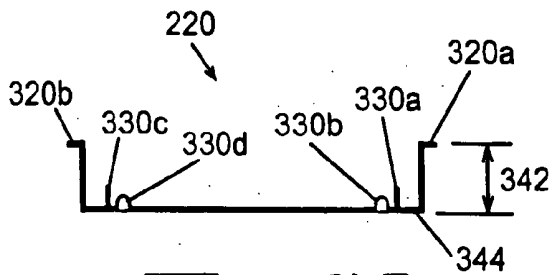

Fig. 14C

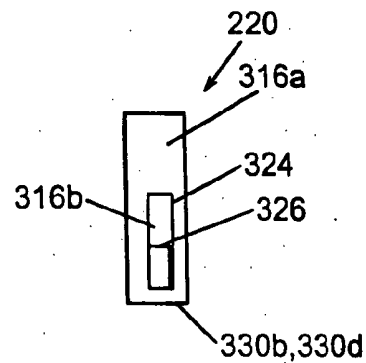

Fig. 14D

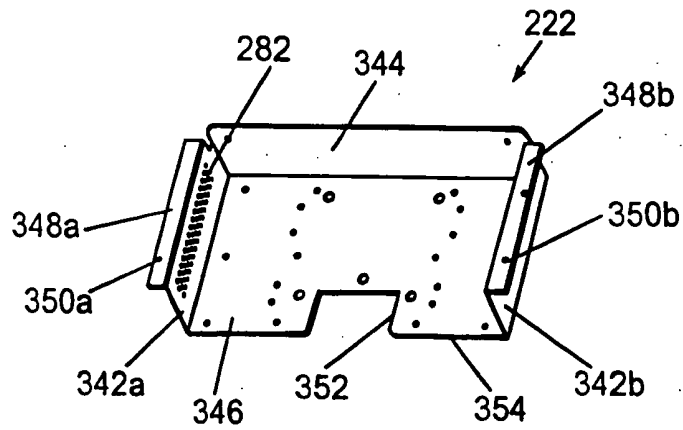

Fig. 15A

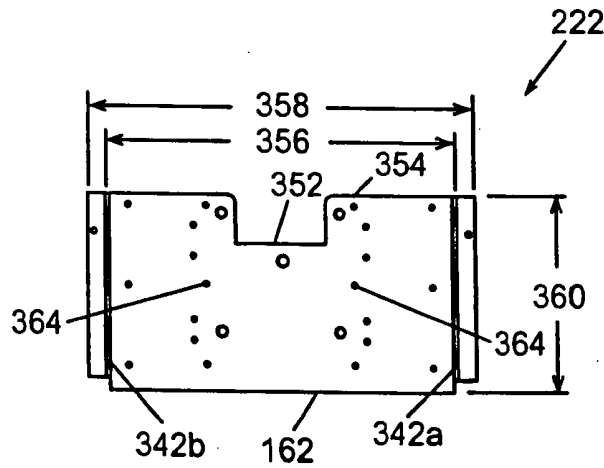

Fig. 15B

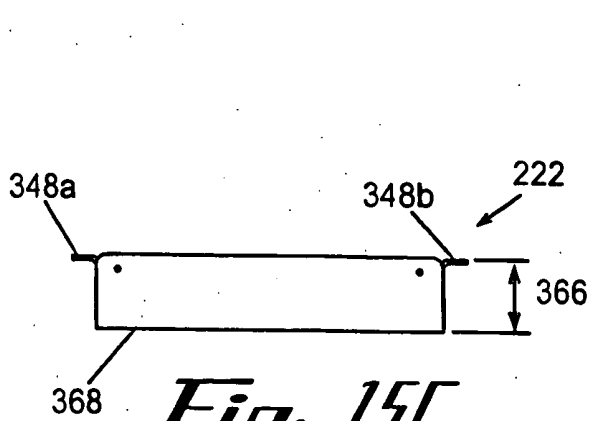

Fig. 15C

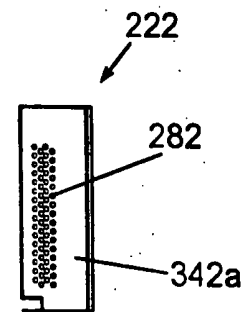

Fig. 15D

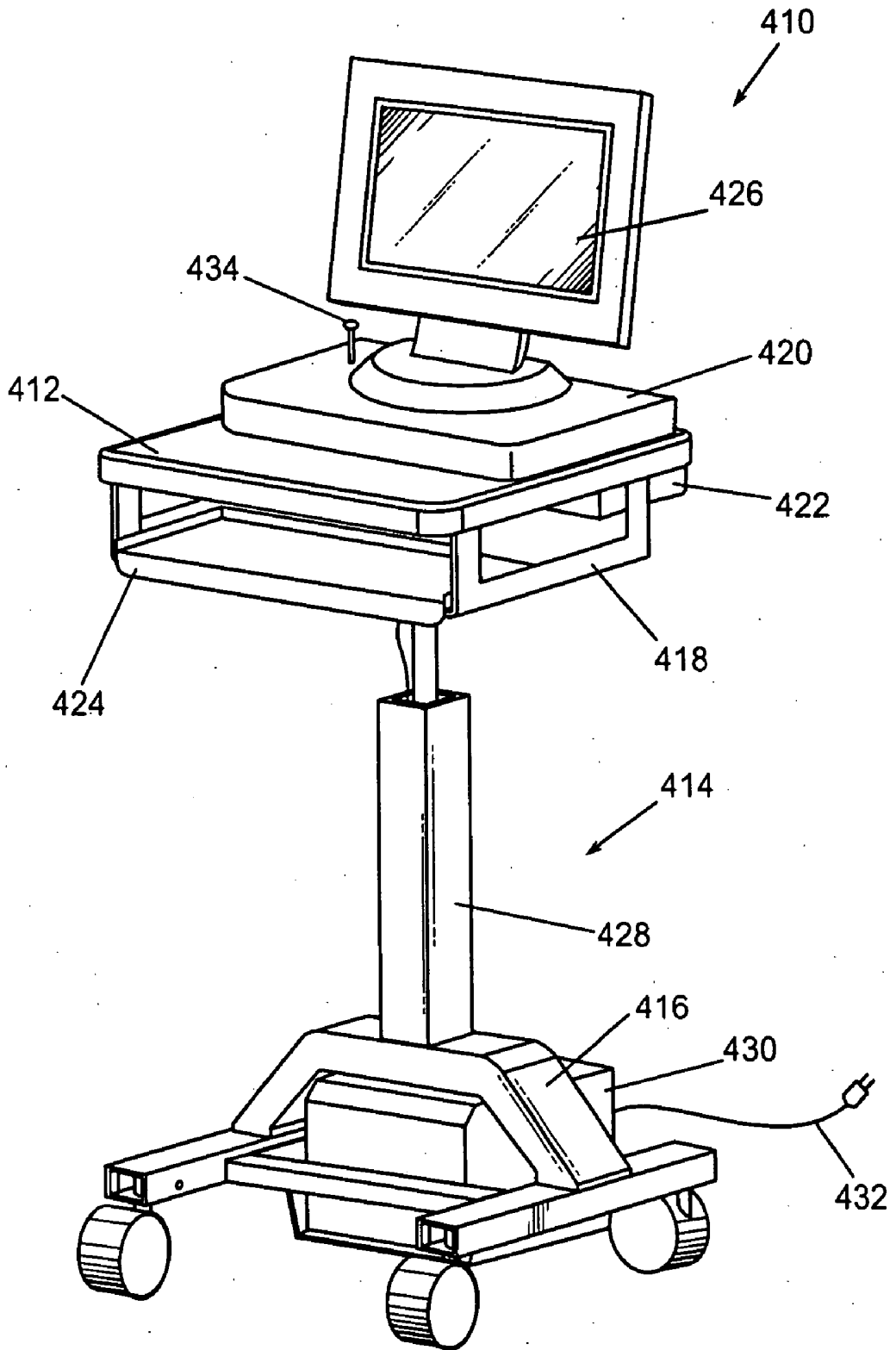

Fig. 16

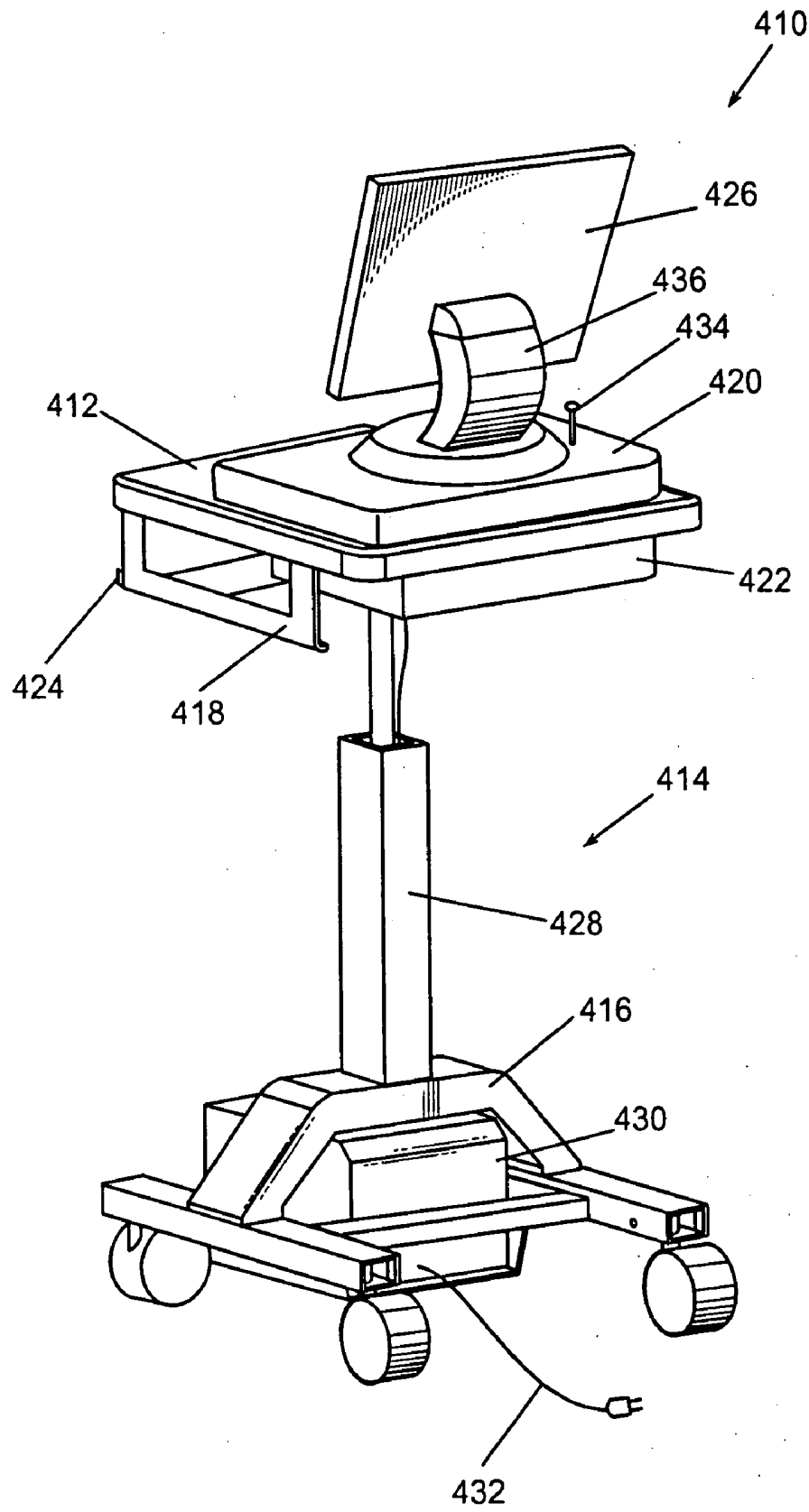

Fig. 11

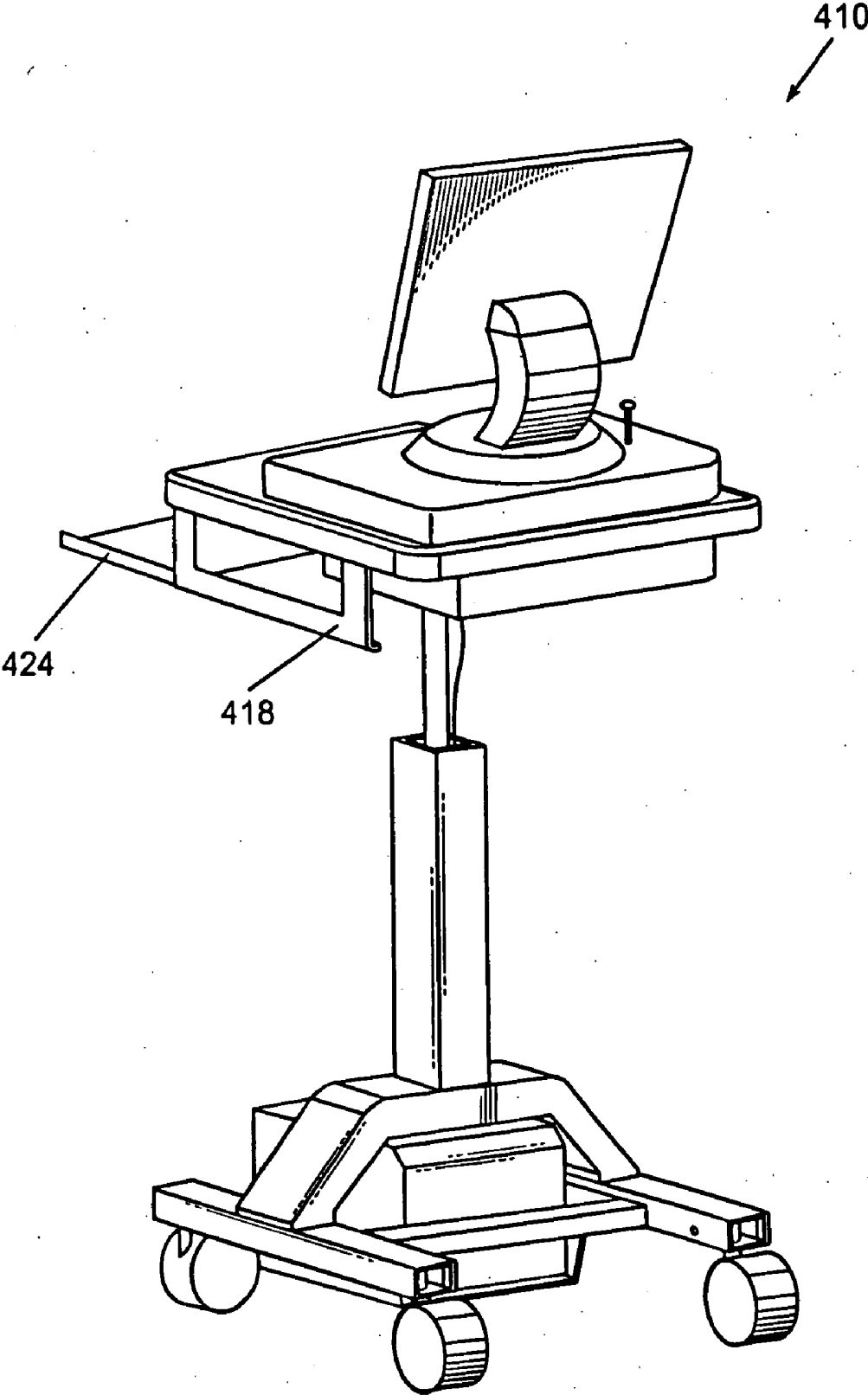

Fig. 18

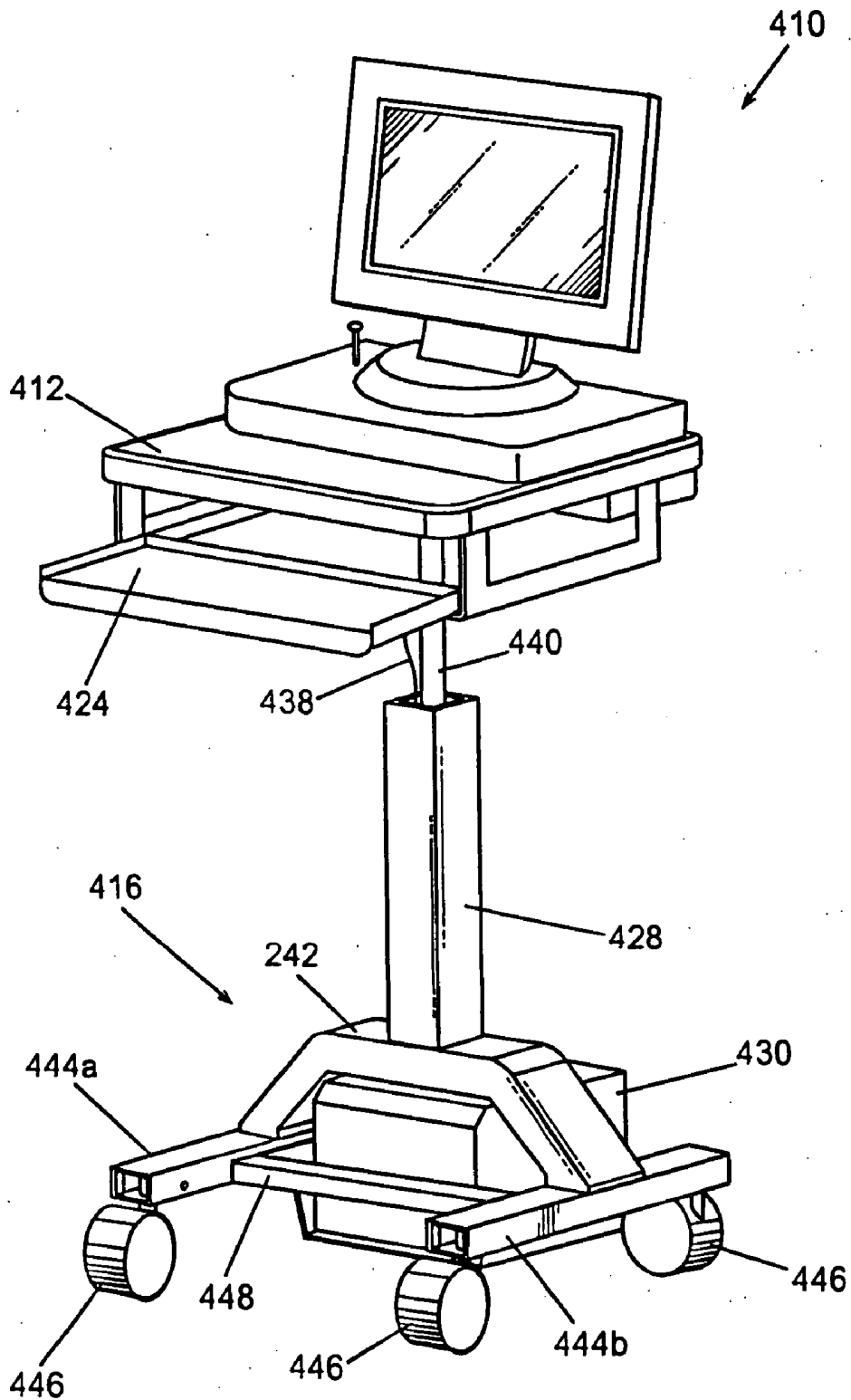

Fig. 19

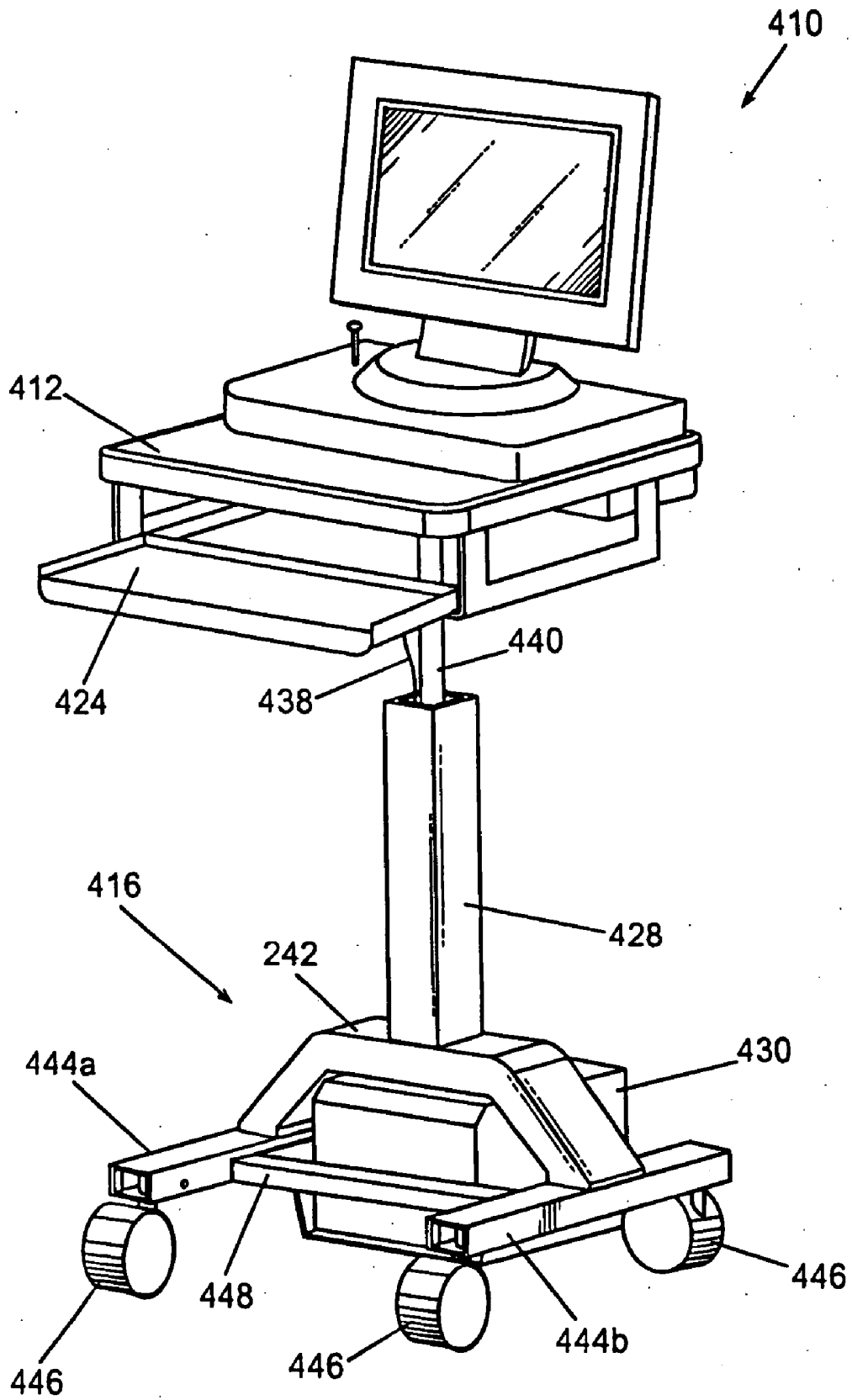

Fig. 19

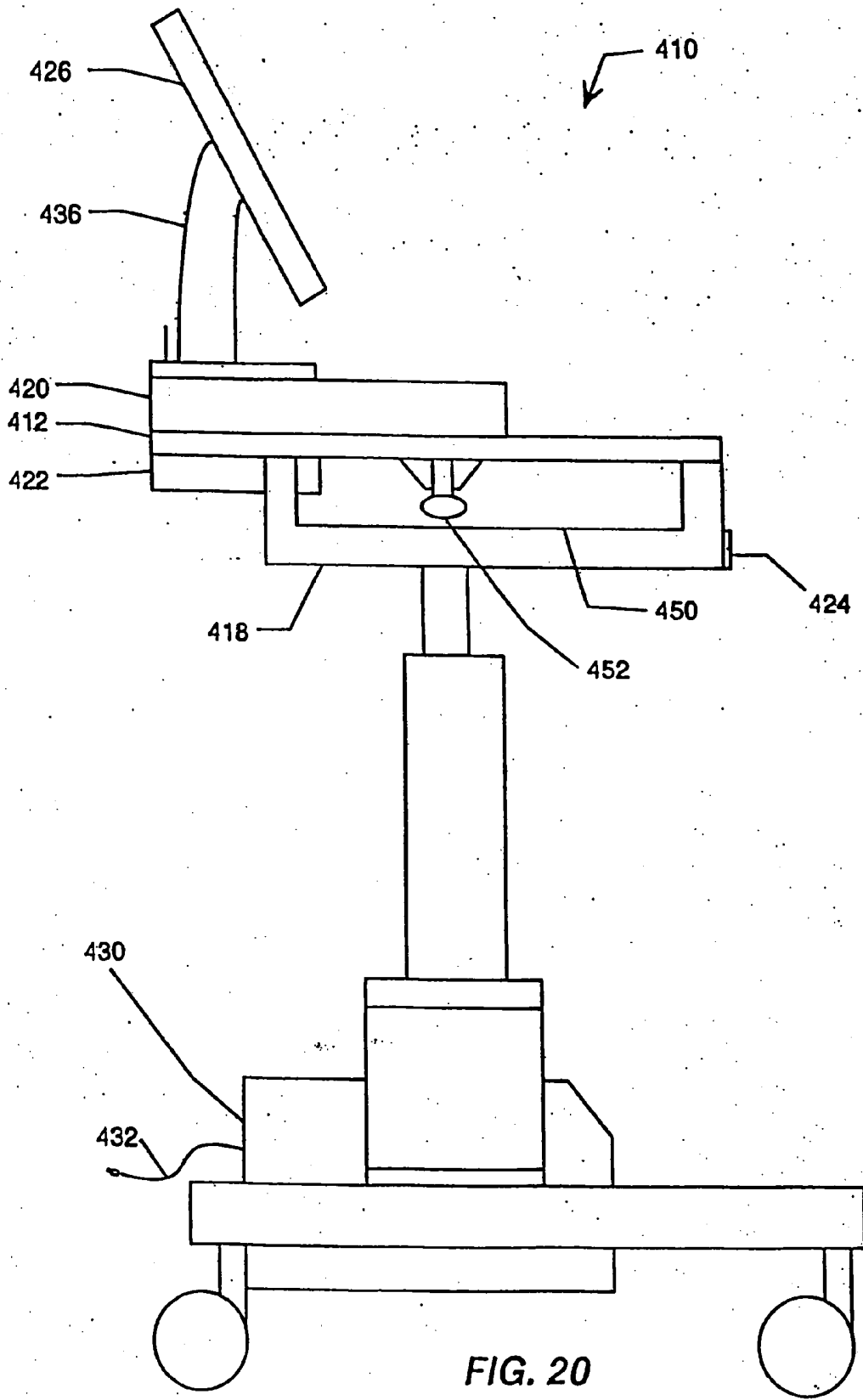

FIG. 20

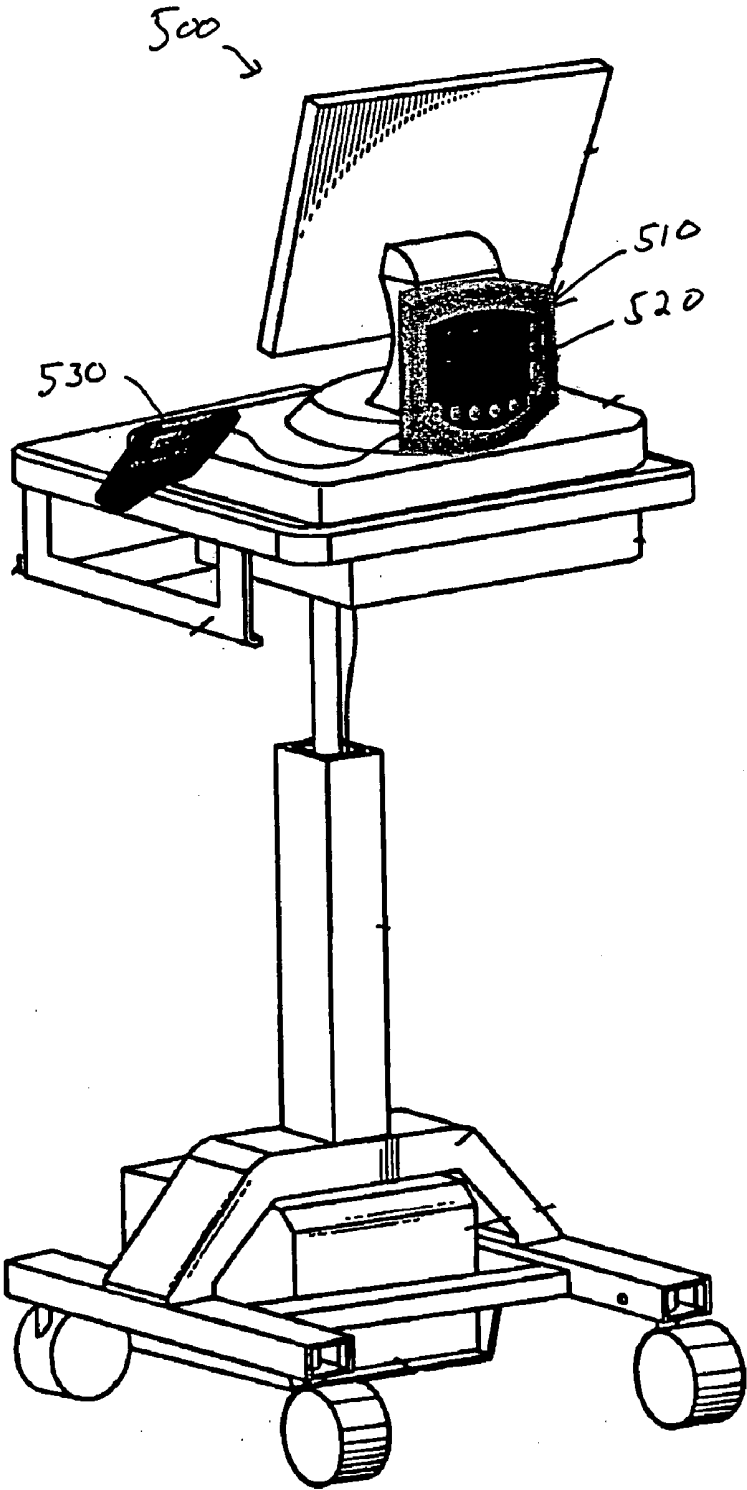

Fig. 21.

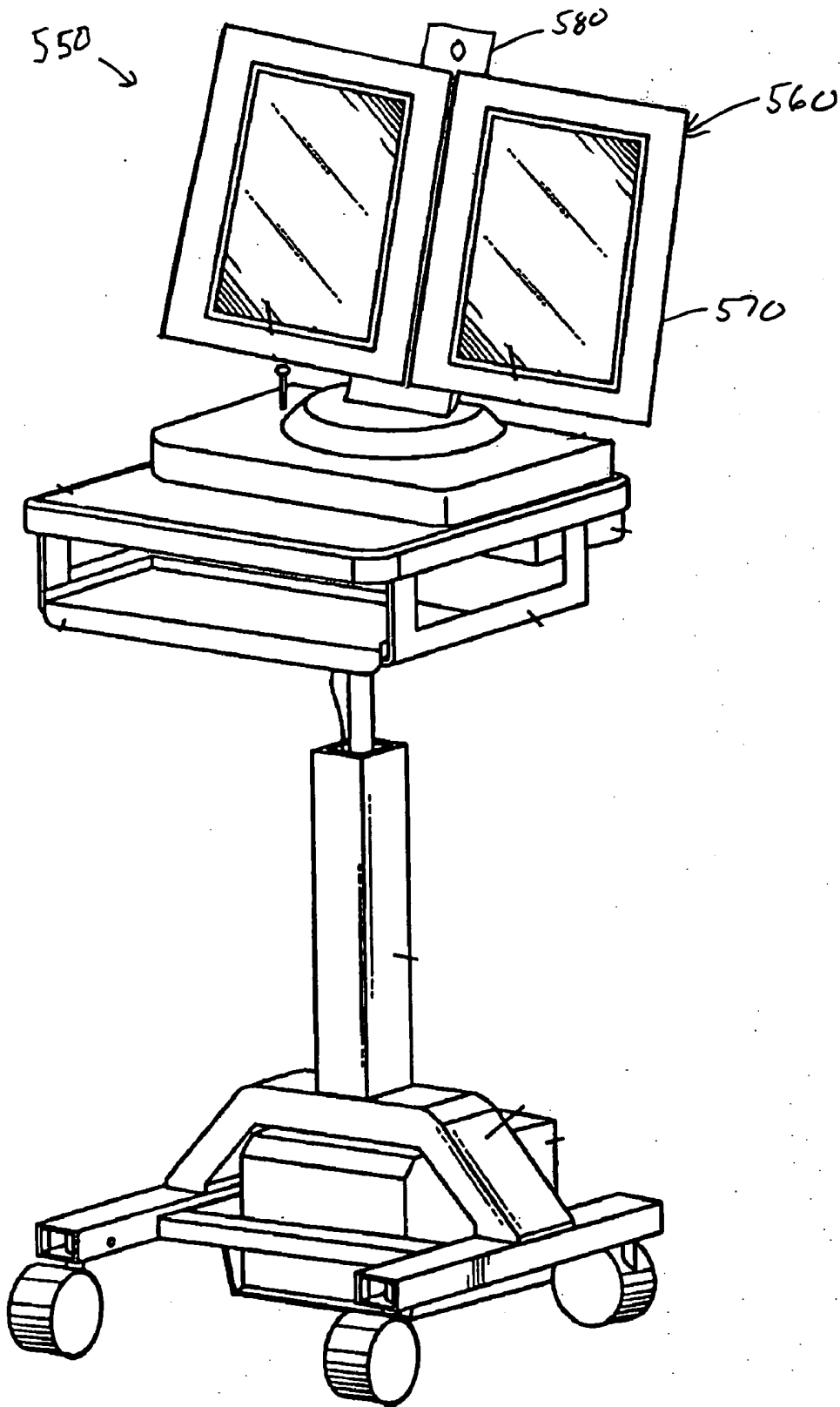

Fig. 22

MOBILE CLINICAL WORKSTATION

RELATED APPLICATIONS

[0001] The present application is a continuation in part of U.S. patent application Ser. No. 10/783,333, filed on Feb. 20, 2004, now allowed, which is a continuation of U.S. patent application Ser. No. 10/171,582, filed on Jun. 13, 2002, now U.S. Pat. No. 6,721,178, which is a continuation of U.S. patent application Ser. No. 09/397,817, filed on Sep. 17, 1999, now U.S. Pat. No. 6,493,220. Each of these applications is incorporated by reference herein.

TECHNICAL FIELD

[0002] This invention relates to mobile workstations and, more particularly, to a mobile workstation that can include an adjustable-height horizontal tray, a pull-out keyboard tray, a vertically-mounted docking station mounted to the tray, a computer terminal mounted beneath the tray, a display screen mounted to the horizontal tray, and a power unit.

BACKGROUND OF THE INVENTION

[0003] Wireless computer terminals are particularly well-suited to medical care environments, such as hospitals, doctors' offices, and nursing homes. Here, wireless computer terminals offer a great advantage by replacing the conventional clipboard hanging from a patient's bed frame or examination table with a wireless computer terminal that uses radio-frequency transmissions to communicate with a distributed computer network. These wireless computer terminals bring bedside medical care into the information age by computerizing medical charts.

[0004] A wireless computer terminal is typically used to post and retrieve the information that was traditionally posted on a bed-side clipboard, such as the patient's prescriptions, vital signs, receipt of medications, scheduled tests, etc. This and other information is now automatically communicated between the wireless computer terminal and a distributed patient-care computer network. A medical practitioner making the rounds, such as a doctor or nurse, usually picks up the wireless computer terminal from a fixed storage location before visiting the patient and takes the terminal into the patient's room. The practitioner then performs the indicated tasks and enters any relevant information into the wireless computer terminal, such as test results, vital signs, observations, and the like. When the visit with the patient is over, the practitioner usually returns the wireless computer terminal to its storage location.

[0005] Deploying a wireless computer terminal in this type of medical care environment presents several challenges. First, the wireless computer terminal should be stored near the patient's hospital or examination room for easy access by the medical practitioner. Second, the wireless computer terminal should be kept secure to prevent theft or tampering. Third, the wireless computer terminal should be easily accessible with one hand because a medical practitioner often has the other hand occupied, for example with a tray of medications, a medical instrument, or the like. Fourth, the battery inside a wireless terminal should be kept charged.

[0006] To address these needs, wireless computer terminals have been deployed in conjunction with wall-mounted

cradles or docking stations located outside of patient hospital rooms. The wall-mounted cradle includes a key or electronic lock for selectively securing the computer terminal in the cradle. For example, the cradle may include a vertically movable leveling tray that allows the wireless terminal to be easily removed from, and replaced for storage within, the cradle with one hand using a push-down-and-tilt motion. A locking mechanism selectively prevents the leveling tray from moving vertically. A battery charger connected to an AC power supply charges the computer terminal's battery while the terminal is stored within the cradle.

[0007] These wall-mounted cradles work well but have a number of drawbacks. In particular, a separate wall-mounted cradle with an associated wireless computer terminal is typically located outside each hospital room. This results in a relatively large number of cradles and associated terminals, with each terminal sitting idle most of the day. Purchasing such a large number of cradles and associated terminals is expensive. In addition, once a practitioner removes the terminal from the cradle and takes it into the patient's hospital room, there may no place to conveniently store the terminal inside the hospital room. The practitioner may have to step back outside the patient's room to return the terminal to the cradle if both hands are needed for another activity during the visit, such as making the bed, assisting the patient to get out of bed, dressing a wound, or some other activity.

[0008] In another attempt to address some of the needs of medical practitioners, a mobile cart has been deployed in conjunction with a laptop computer. The mobile cart includes a horizontal tray with an upper surface on which the laptop computer resides. The laptop computer is typically secured on the mobile cart with a KENSINGTON lock (i.e., a cylinder-type key-operated mechanical lock). This mobile cart with an attached laptop computer has some advantages, but it also has a number of drawbacks. Physically walking back and forth from the patient's bedside to the mobile cart to enter patient information into the computer can be inconvenient. In many cases, a removable computer terminal that can be carried over to the patient's bedside would be more convenient. A removable computer terminal more closely resembles a conventional clipboard chart, which may be preferred by practitioners who have grown accustomed to clipboard charts.

[0009] In the previous mobile cart design, however, the practitioner must manually unlock the KENSINGTON lock to remove the laptop computer. This can be inconvenient, particularly when the medical practitioner is holding other items, such as medical instruments. The KENSINGTON lock itself, which typically dangles from a cable connected to the computer, can be an annoyance. In addition, the location of the laptop computer on the surface of the cart occupies this space, which might be better used as a workspace for the practitioner to make notes, carry instruments, place medications, and so forth. The laptop computer also has a number of limitations. For example, the computer's battery life is typically about two to three hours, and recharging the battery typically requires plugging the laptop computer's power cord into an AC outlet for several hours. Plugging the laptop computer in for recharging typically idles the mobile cart for this period.

[0010] There is, therefore, a need for an improved docking station for a wireless computer terminal. Specifically, there

is a need for a docking station that eliminates the need for a wall-mounted cradle and an associated wireless computer terminal located outside each patient hospital room. There is a further need for a mobile cart and associated computer terminal that is more convenient to use, has increased workspace, and has increased battery life.

SUMMARY OF THE INVENTION

[0011] The present application thus provides a mobile workstation for use with a computer network. The mobile workstation may include a medical monitoring device, a radio transceiver in communication with the medical monitoring device operable for receiving and sending data to the computer network, a display screen, and a wheeled chassis for mounting the medical monitoring device, the radio transceiver and the display screen.

[0012] The mobile workstation further may include a computing device positioned on the wheeled chassis and in communication with the medical monitoring device. The mobile workstation further may include a power supply positioned on the wheeled chassis. The mobile workstation further may include a videoconferencing system.

[0013] The medical monitoring device may include a vital signs capture device. The vital signs capture device may include a monitor/control device. The vital signs capture device may include a sensor. The sensor may include a blood pressure cuff, a thermometry sensor, a pulse oximetry sensor, or a similar type of device.

[0014] The present application further describes a mobile workstation for use with a computer network. The mobile workstation may include a videoconferencing system, a radio transceiver in communications with the videoconferencing system and operable for receiving and sending data to the computer network, and a wheeled chassis for mounting the videoconferencing system and the radio transceiver.

[0015] The mobile workstation further may include a computing device positioned on the wheeled chassis and in communication with the medical monitoring device. The mobile workstation further may include a power supply positioned on the wheeled chassis. The mobile workstation further may include a vital signs capture device positioned on the wheeled chassis.

[0016] The videoconferencing system may include a video screen or a dual video screen. The videoconferencing system may include a diagnostic image or electronic medical records. The videoconferencing system may include a video camera.

[0017] The present application further describes a method of using a mobile workstation. The method may include rolling the mobile workstation about a patient, viewing the patient's electronic medical records on the mobile workstation, and conferencing with a third party via the mobile workstation.

[0018] That the invention improves over the drawbacks of the prior art and how it accomplishes the advantages described above will become apparent from the following detailed description of the exemplary embodiments and the appended drawings and claims.

BRIEF DESCRIPTION OF THE DRAWINGS

[0019] FIG. 1 illustrates a mobile workstation including a docking station for a computer terminal in a typical environment, such as a patient's hospital room.

[0020] FIGS. 2A-2D are a series of side views of the mobile workstation of FIG. 1 illustrating the operation of an adjustable-height horizontal tray and a tiltable docking station.

[0021] FIGS. 3A-3D are a series of perspective views of the docking station forming part of the mobile workstation of FIG. 1 showing the push-down-and-tilt motion used to remove the wireless terminal from the docking station.

[0022] FIGS. 4A-4B are perspective views of the mobile workstation of FIG. 1 showing the operation of a pull-out keyboard tray.

[0023] FIG. 5A is a side view of the horizontal tray of the mobile workstation of FIG. 1 showing an access hole and a release lever for raising and lowering the horizontal tray.

[0024] FIG. 5B is a perspective view of the horizontal tray of the mobile workstation of FIG. 1 showing an access hole and a release lever for raising and lowering the horizontal tray.

[0025] FIG. 6A is a back view of the horizontal tray and mounting bracket of the mobile workstation of FIG. 1.

[0026] FIG. 6B is a reverse view of the mounting bracket of FIG. 6A.

[0027] FIG. 7A is an exploded view the mounting bracket of FIG. 6A and associated clutch assemblies.

[0028] FIG. 7B is a side view of a spring washer for the clutch assemblies.

[0029] FIG. 7C is a perspective view of the spring washer of FIG. 7B.

[0030] FIG. 8 illustrates a mobile workstation including a computer terminal and a display screen in a typical environment, such as a patient's hospital room.

[0031] FIGS. 9A-9D are a series of side views of the mobile workstation of FIG. 8 illustrating the operation of an adjustable-height horizontal tray and a tiltable display screen.

[0032] FIGS. 10A-10B are perspective views of the mobile workstation of FIG. 8 showing the operation of a pull-out keyboard tray.

[0033] FIG. 11A is a side view of the horizontal tray of the mobile workstation of FIG. 8 showing an access opening and a release lever for raising and lowering the horizontal tray.

[0034] FIG. 11B is a perspective view of the horizontal tray of the mobile workstation of FIG. 8 showing an access opening and a release lever for raising and lowering the horizontal tray.

[0035] FIG. 12A is a perspective view of the mobile workstation of FIG. 8 showing the installation of the wireless computer terminal and the keyboard.

[0036] FIG. 12B is a side view of the mobile workstation of FIG. 8 showing the installation of the wireless computer terminal, keyboard, and battery pack.

[0037] FIG. 12C is a front view of the mobile workstation of FIG. 8 showing the installation of the wireless computer terminal and the keyboard.

[0038] FIG. 13A is a perspective view of the horizontal tray and tray housing of the mobile workstation of FIG. 8.

[0039] FIG. 13B is a top view of the horizontal tray and mounting bracket of FIG. 13A.

[0040] FIG. 13C is a front view of the horizontal tray and mounting bracket of FIG. 13A with an installed wireless computer terminal and keyboard.

[0041] FIG. 13D is a side view of the horizontal tray and mounting bracket of FIG. 13A with an installed wireless computer terminal and keyboard.

[0042] FIG. 14A is a perspective view of the front mounting bracket of the mobile workstation of FIG. 8.

[0043] FIG. 14B is a top view of the front mounting bracket of FIG. 14A.

[0044] FIG. 14C is a front view of the front mounting bracket of FIG. 14A.

[0045] FIG. 14D is a side view of the front mounting bracket of FIG. 14A.

[0046] FIG. 15A is a perspective view of the back mounting bracket of the mobile workstation of FIG. 8.

[0047] FIG. 15B is a top view of the back mounting bracket of FIG. 15A.

[0048] FIG. 15C is a front view of the back mounting bracket of FIG. 15A.

[0049] FIG. 15D is a side view of the back mounting bracket of FIG. 15A.

[0050] FIG. 16 is a front perspective view of yet another embodiment of a mobile workstation.

[0051] FIG. 17 is a rear right side perspective view of the mobile workstation in FIG. 16.

[0052] FIG. 18 is a rear right side perspective view of the mobile workstation in FIG. 16 with a pull-out keyboard tray in the extended position.

[0053] FIG. 19 is a front right side perspective view of the mobile workstation in FIG. 16 with the pull-out keyboard tray in the extended position.

[0054] FIG. 20 is a side view of the mobile workstation shown in FIG. 16.

[0055] FIG. 21 is a rear perspective view of an alternative embodiment of a mobile workstation with a vital signs capture device.

[0056] FIG. 22 is a front perspective view of an alternative embodiment of a mobile workstation with a videoconferencing system.

DETAILED DESCRIPTION OF THE DISCLOSED EMBODIMENTS

[0057] The present invention may be embodied in a mobile workstation that includes an adjustable-height horizontal tray and a vertically-mounted docking station mounted to the horizontal tray. The docking station removably supports a computer terminal having a display screen, which may also serve as a touch-sensitive input device, that can be easily seen and accessed when the computer terminal is stored within the docking station. The mobile workstation

also includes a keyboard located on a pull-out keyboard tray mounted to the underside of the horizontal tray. The keyboard is connected to the computer terminal by way of the docking station, so that the keyboard is automatically connected to the computer terminal whenever the terminal is stored within the docking station.

[0058] A tiltable bracket mounts the docking station to the horizontal tray. A clutch assembly allows the angle of the bracket, and along with it the angle of the docking station and the computer terminal, to be adjusted to avoid glare on the terminal's display screen. A spring-mounted, vertically-movable leveling tray allows the wireless terminal to be easily removed from the docking station using a push-down-and-tilt motion. An electronic lock selectively prevents vertical movement of the leveling tray to secure the computer terminal within the docking station. The docking station may also include a key-operated lock, which may be used to unlock the docking station in the event of a power outage or if the electronic lock should fail.

[0059] The mobile workstation also carries a power converter and a power unit including an extended-life battery, a battery charger that connects to an AC power supply to charge the conventional battery located inside the computer terminal as well as the extended-life battery carried on the mobile workstation. The power converter converts electrical power supplied by the battery to a suitable electrical input source for the computer terminal and the terminal display. The rechargeable battery power supply increases the battery life of the computer terminal to about 8-12 hours, which allows use of the computer terminal for an extended time before having to fully recharge it. The power unit includes two status-indicator lights to indicate when the unit is operating on AC power and when the battery is low, and a seven-level battery status-indicator light. The power unit may also include a sensor that indicates when the battery is low.

[0060] With the docking station configuration described above, a medical practitioner making the rounds can push the mobile workstation from room to room and use the same computer terminal when attending each patient. The extended-life battery allows the mobile workstation to be used for an entire shift before recharging. The mobile workstation thus eliminates the need for locating a wall-mounted cradle and associated computer terminal outside each patient's room. Because the docking station is vertically mounted, the computer terminal does not occupy the top surface of the horizontal tray, which allows this area to be used as a work surface. The leveling tray allows the computer terminal to be easily removed from, and replaced for storage within, the docking station with one hand. The electronic lock allows the docking station to be easily locked and unlocked with one hand.

[0061] Another embodiment of the present invention may be embodied in a mobile workstation that includes an adjustable-height horizontal tray on a chassis, a vertically mounted display screen mounted above the horizontal tray, a wireless computer terminal and a power converter mounted underneath the horizontal tray, a pull-out keyboard tray mounted beneath the wireless computer terminal, and a power unit mounted to the chassis. The horizontal tray includes an underside front mounting bracket to support the wireless computer terminal, and a rear mounting bracket to

support the power converter. The front mounting bracket supports the wireless computer terminal adjacent to and beneath the horizontal tray, leaving the work surface of the horizontal tray available for other operator uses. The back mounting bracket or wiring tray supports the power converter adjacent to and beneath the horizontal tray so that the power converter easily connects to the wireless computer terminal. A tray housing mounted to the underside of the horizontal tray supports a pull-out keyboard tray so that a keyboard mounted within the pull-out tray does not interfere with the front mounting bracket or the rear mounting bracket. The keyboard communicates with the computer terminal through a conventional electrical connection so that the keyboard can be easily connected to the computer terminal whenever the wireless computer terminal is stored within the mobile workstation. The wireless computer terminal removably connects to the display screen that mounts to the top surface of the horizontal tray with a tiltable bracket.

[0062] The mobile workstation also carries a power unit including an extended-life battery and a battery charger that connects to an AC power supply to charge the conventional battery located inside or adjacent to the wireless computer terminal as well as the extended-life battery carried on the mobile workstation. Each battery connects to the power converter to supply power to the wireless computer terminal and the terminal display through the power converter. The rechargeable battery power supply increases the battery life of the computer terminal to about 8-12 hours, which allows use of the computer terminal for an extended time before having to fully recharge it. The power unit includes two status-indicator lights to indicate when the unit is operating on AC power and when the battery is low, and a seven-level battery status-indicator light. The power unit may also include a sensor that indicates when the battery is low.

[0063] Yet another embodiment of the present invention may include an adjustable-height horizontal tray on a chassis, a wireless computer terminal mounted above the horizontal tray, a display screen mounted above the wireless computer terminal, a pull-out keyboard tray mounted beneath the horizontal tray, and a power unit mounted to the chassis. The horizontal tray includes a mounting bracket to support the wireless computer terminal above the horizontal tray, leaving the part of the work surface of the horizontal tray available for other operator uses. A tray housing mounted to the underside of the horizontal tray supports a pull-out keyboard tray so that a keyboard mounted within the pull-out tray does not interfere with the bottom of the horizontal tray. The keyboard communicates with the computer terminal through a conventional electrical connection so that the keyboard can be easily connected to the computer terminal whenever the wireless computer terminal is stored within the mobile workstation. The wireless computer terminal removably connects to the display screen that mounts to the top surface of the horizontal tray with a tiltable bracket.

[0064] The mobile workstation also carries a power converter and a power unit including an extended-life battery and a battery charger that connects to an AC power supply to charge the conventional battery located inside or adjacent to the wireless computer terminal as well as the extended-life battery carried on the mobile workstation. Each battery connects to the power converter to supply power to the

wireless computer terminal and the terminal display through the power converter. The rechargeable battery power supply increases the battery life of the computer terminal to about 8-12 hours, which allows use of the computer terminal for an extended time before having to fully recharge it. The power unit includes two status-indicator lights to indicate when the unit is operating on AC power and when the battery is low, and a seven-level battery status-indicator light. The power unit may also include a sensor that indicates when the battery is low.

[0065] With the wireless computer terminal configurations described above, a medical practitioner making the rounds can push the mobile workstation from room to room and use the same computer terminal when attending each patient. The extended-life battery allows the mobile workstation to be used for an entire shift before recharging. The mobile workstation thus eliminates the need for locating a wall-mounted cradle and associated computer terminal outside each patient's room. When the computer terminal is mounted beneath the horizontal tray, the computer terminal does not occupy the top surface of the horizontal tray, which allows this area to be used as a work surface. The front mounting bracket allows the computer terminal to be easily removed from, and replaced for storage within, the front mounting bracket. In the embodiment where the computer terminal is mounted above the horizontal tray, the computer terminal does not occupy the entire top surface of the horizontal tray, which allows the remaining area to be used as a work surface. In this configuration, the mounting bracket above the horizontal tray allows the computer terminal to be easily removed from, and replaced for storage within, the mounting bracket.

[0066] The wireless computer terminal in a mobile workstation can also communicate through a radio-frequency communication channel via a radio transmitter/receiver terminal antenna attached to the top of the horizontal tray. In this manner, the wireless computer terminal can exchange information with a computer network, such as a distributed patient-care computer network.

[0067] Those skilled in the art will appreciate that the mobile workstation could be configured to support a device other than a docking station or a wireless computer terminal, such as a medical instrument. For example, the mobile workstation could be configured to support an ultra-sound device used to view a fetus. The docking station or the wireless computer terminal could be removed from the mobile workstation, and a similarly sized ultra-sound device could be placed within the mobile workstation. The patient could then view the display screen of the mobile workstation to see the results of the ultra-scan procedure. Many other applications, both medical and non-medical, will become apparent to those skilled in the art from the examples described in this specification.

[0068] Turning now to the drawings, in which like numerals indicate like elements throughout the several figures, FIG. 1 illustrates a mobile workstation 10 in a typical environment, such as a patient's hospital room 5. The mobile workstation 10 includes an adjustable-height horizontal tray 12 supported by a chassis 14. The chassis 14 includes a dolly assembly 16 that allows an operator, such as a medical practitioner, to easily push the mobile workstation 10 from place to place. The horizontal tray 12 supports a docking

station 18 that, in turn, removably supports a device, such as the wireless computer terminal 20 with a terminal display screen. The chassis 14 includes a vertical beam 22 connecting the horizontal tray 12 to the dolly assembly 16.

[0069] The vertical beam 22 includes a gas-spring height adjustment mechanism for adjusting the length of the beam and, thus, the height of the horizontal tray 12 above the dolly assembly 14. For example, the chassis 14 may be a model MPC2001 manufactured by JACO, Inc. with the standard tray replaced by the horizontal tray 12 shown in FIG. 1. Those skilled in the art will appreciate that other types of wheeled chassis would be suitable for this purpose. In addition, other types of height adjustment mechanisms would also be suitable, such as a rack and pinion mechanism, a cable and pulley mechanism, a ratchet mechanism, a ball screw mechanism, a removable pin and holes arrangement, and so forth. Nevertheless, a gas-spring height adjustment mechanism is preferred because it is easy operate and ergonomically desirable.

[0070] The mobile workstation 10 also carries a power unit 24 including a power converter, a battery charger, an extended-life battery, a power cord 26, and a recoil mechanism that automatically recoils the power cord when the cord is not plugged into an AC outlet. The power converter converts power received from the power unit 24 to suitable power for the wireless computer terminal 20. The power unit 24 is located on the lower end of the chassis 14. For example, the power unit 24 may reside between two metal beams in the dolly assembly 16 at the lower end of the chassis 14. The extended-life battery may be a 12-Volt sealed lead acid battery, and the power supply may be a 120-Volt AC to 16-Volt DC converter.

[0071] The power unit 24 typically includes a first status-indicator light to inform the user when the unit is running on AC power, a second status-indicator light to inform the user when the battery needs recharging, and a seven-level battery status-indicator light to inform the user about the power status of the battery. The power unit 24 may also include an alarm or audible indicator to inform the user when the extended-life battery power needs recharging. The extended-life battery can be recharged by connecting the plugging the power cord 26 into a standard 120-volt AC outlet. When not in use, the recoil mechanism retracts the power cord 26 into the power unit 24.

[0072] The wireless computer terminal 20 typically includes a radio transmitter/receiver antenna for communicating over an approved radio frequency. In particular, the wireless computer terminal 20 may establish a radio-frequency communication channel 28 with a distributed patient-care computer network 30 through an antenna 32 connected to a network access point 34. This network access point is typically located in an enclosure 36 located above the ceiling of the hospital room. The network access point 34, in turn, allows the wireless computer terminal 20 to communicate with the distributed patient-care computer network 30. For example, the network access point 34 may be a RANGELAN2 7500 Series Access Point manufactured by PROXIM, INC. of Mountain View, Calif.

[0073] FIGS. 2A-2D are a series of side views of the mobile workstation 10 illustrating the operation of an adjustable-height horizontal tray 12 and the tiltable docking station 18. FIG. 2A shows the mobile workstation 10 with the

height-adjustable horizontal tray 12 in a vertically lowered position. To raise the tray, the operator places his or her hand through an opening 40 in the side of the horizontal tray 12. The operator then lifts a release lever 42, which releases a stop in the gas-spring height adjustment mechanism in the vertical beam. The operator then raises or lowers the horizontal tray 12 while holding the release lever 42 in a raised position.

[0074] Assistance provided by the gas-spring height adjustment mechanism allows the operator to change the height of the horizontal tray 12 with little effort. Once the horizontal tray 12 is at a desired height, represented by the height shown in FIG. 2B, the operator releases the lever 42, which locks the tray at the desired height. With this type of mechanism, the operator can quickly and easily place the horizontal tray 12 at virtually any height within the adjustment range of the gas-spring height adjustment mechanism. The assistance provided by the gas-spring height adjustment is ergonomically desirable in that it avoids back strain or other lifting problems that could otherwise be encountered by operators using the mobile workstation 10.

[0075] FIG. 2C illustrates the mobile workstation 10 with the docking station 18 in a vertical position. A tiltable bracket 44 attaches the docking station 18 to the horizontal tray 12. A clutch 46 in the tiltable bracket maintains the docking station 18 in a number of selectable rotational positions relative to the tray 12. The rotational range of the tiltable bracket 44 is preferably about 30 degrees rearward from vertical. That is, the tiltable bracket 44 preferably allows the docking station 18 to be rotated from the position shown in FIG. 2C to the position shown in FIG. 2D. The tiltable bracket 44 could also be configured to allow the docking station 18 to rotate forward through a similar rotational range.

[0076] It should be understood that the term "substantially vertical" may include a range about a strictly vertical orientation, represented by the 30 degree range illustrated by FIGS. 2C-D. For example, the term "substantially vertical" includes configurations in which the bracket 44 maintains the docking station 18 in a strictly vertical orientation, or at a fixed rotational orientation with a vertical component, or within a range of rotational orientations including orientations that include vertical components. Alternatively, the docking station 18 could be supported in a substantially horizontal position, for example by a drawer or pull-out tray located above or under the horizontal tray 12. Other locations for the docking station 18 may be preferred in certain environments. For example, the docking station could be mounted to the side of the horizontal tray 12, to the underside of the horizontal tray 12, to the dolly assembly 16, to the vertical beam 22, and so forth.

[0077] The clutch 46 imparts sufficient rotational resistance to maintain the docking station 18, with an associated computer terminal 20, at any of the rotational aspects within the rotational range defined by the tiltable bracket 44. At the same time, the rotational resistance imparted by the clutch 46 is pliant enough to allow the operator to change the rotational orientation of the docking station 18 with one hand. For example, the operator may easily adjust the angle of the docking station 18 to avoid glare on the display screen of the computer terminal 20. The tiltable bracket 44 and the clutch 46 are described in greater detail with reference to FIGS. 6A-B and 7A-C below.

[0078] FIGS. 3A-3D are a series of perspective views of the docking station 18 and an associated wireless computer terminal 20 showing the push-down-and-tilt motion used to remove the terminal from the docking station. The docking station 20 includes a base 50, a back plane 52, and two spaced-apart retaining arms 54 and 56. When the computer terminal 20 is located in the docking station, the retaining arms 54 and 56 support the top side 62 of the terminal. The base 50 includes a leveling tray 58 with a rubber cushion 60 for receiving the bottom side of the computer terminal 20. The rubber cushion 60 includes raised collars on either end that prevent the computer terminal 20 from being removed from the docking station 18 when the leveling tray 58 is locked in the upper position, as shown in FIG. 3A.

[0079] The docking station 18 includes a control panel 62 having a keypad 64, typically with four keys. The docking station 18 may be configured so that the keypad 64 operates as an electronic combination lock. The leveling tray 58 can be depressed when the docking station is unlocked and, when the docking station 18 is locked, the leveling tray 58 cannot be depressed. The docking station 18 may also include a manual key lock that may be used to lock and unlock the docking station in the event of a power outage or a malfunction of the electronic lock.

[0080] The control panel 62 may also include status lights 64a-c that indicate status information regarding the docking station 18. For example, these status lights typically indicate whether the docking station is locked, whether power is on, and provide status information while a user is configuring the docking station with passwords. A touch-pin battery charging terminal 68 or other conventional electrical connection located in the leveling tray 58 may be used to charge a battery within the computer terminal 20 while the terminal is stored within the docking station 18. This battery charging terminal, in turn, is connected to the power unit 24. The power unit includes the power cord 26, which may be plugged into a standard 120 Volt AC outlet. In addition, the docking station 18 may include a communication interface, such as an optical interface, for communicating data between the computer terminal 20 and the docking station 18 while the terminal is stored within the docking station. This allows the computer terminal 20 to communicate with the keypad 64 and/or an optional keyboard that plugs into the docking station 18.

[0081] To remove the computer terminal 20, an operator first unlocks the docking station 18 and then places his or her hand on the top side 62 of the terminal and pushes downward. Provided that the docking station 18 is unlocked, this motion depresses the leveling tray 58, as shown in FIG. 3B. The operator then tilts the terminal 20 forward, as shown in FIG. 3C, and removes the terminal 20, as shown in FIG. 3D. An example of a suitable docking station is described in commonly owned U.S. patent application Ser. No. 08/841,496, entitled "Cradle For Holding A Device," filed Apr. 23, 1997, which is incorporated into this specification by reference.

[0082] FIGS. 4A-B are perspective views of the mobile workstation 10 showing the operation of a pull-out keyboard tray 70, which is supported by the underside of the horizontal tray 12. The pull-out keyboard tray 70 slides from an inner position, shown in FIG. 4A, to an outer position, shown in FIG. 4B. A keyboard mounted on the keyboard tray

70 typically plugs into the docking station 18, which communicates keystrokes with the computer terminal 20 by way of a conventional electrical connection. This allows an operator to easily remove the computer terminal 20 from the docking station 18.

[0083] In FIGS. 4A-4B, the top portion of a rectangular cover for the vertical beam 22 has been removed, showing an underlying shaft 72 and a power cable 73 connecting the power unit 24 to the docking station 18. This shaft 72 connects to the gas-spring height adjustment mechanism 74 that allows adjustment of the height of the horizontal tray 12. The gas-spring height adjustment mechanism 74, which is located at the bottom of the vertical beam 22, sits on top of the dolly assembly 16. This dolly assembly includes an arched cross-beam 76 that connects to two horizontal runner beams 78a-b. Two casters, represented by the caster 80, are connected to the bottom sides of each horizontal runner beam 78a-b. The power unit 24 is mounted below the arched cross beam 76 to an arched support plate 82, which connects between the horizontal runner beams 78a-b.

[0084] FIGS. 4A-B also show that the top side of the horizontal tray 12 defines a substantially horizontal work surface 86, which is bordered by a raised edge guard 88. The rear edge of the horizontal tray 12 includes a recess 90 for the docking station 18, which defines an elongate dimension 92 and a relatively slender dimension 94. That is, the docking station 18 is substantially taller than it is thick. The tiltable mounting bracket 44 supports the docking station 18 so that the elongate dimension 92 is substantially vertical and the relatively slender dimension 94 is substantially horizontal. Because the docking station 18 is vertically mounted, the terminal 20 does not occupy the top surface 86 of the horizontal tray 12, which allows this area to be used as a work surface. In addition, the computer terminal 20 typically includes a display screen 96, and the docking station 18 supports the terminal with the display screen substantially perpendicular to and above the top surface 86 of the horizontal tray 12 for easy viewing. It will be understood that the term "substantially perpendicular" includes a range of orientations because the docking station 18 may rotate through a rotational range about a strictly perpendicular orientation.

[0085] FIG. 5A is a side view of the horizontal tray 12 showing the access hole 40 and the release lever 42 for raising and lowering the horizontal tray 12. The release lever 42 operates the gas-spring height adjustment lever, which is shown best in FIG. 4A. FIG. 5A also shows the end of the pull-out keyboard tray 70, which includes a lip 98 to aid in pulling the keyboard tray out and pushing it back in.

[0086] FIG. 5B is a perspective view of the horizontal tray 12 showing the access hole 40 and the release lever 42 for raising and lowering the horizontal tray 12. FIG. 5B also shows the top surface 86, the edge guard 88, and the recess 90 of the horizontal tray 12. The top surface 86 of the horizontal tray 12 is preferably constructed from a non-porous material, such as plastic or metal. For example, the horizontal tray 12 may be constructed from a flat wooden, particle board, or composite substrate covered with a plastic overlay defining the top surface 86 and the edge guard 88. The plastic overlay may be created with an injection mold, and then glued to the substrate. The bracket 44 includes mounting brackets 102a-b and a back plane 100 supporting

the docking station. The back plane **100** may be formed from a heavy gauge sheet metal, fiberglass, or composite. The sides **103** and bottom **104** the horizontal tray **12** may be formed from sheet metal.

[0087] FIG. 6A is a back view, and FIG. 6B is a reverse view, of the horizontal tray **12** showing the tiltable bracket **44**, including the back plane **100** and mounting brackets **102a-b**. The mounting brackets **102a-b** are bolted to the rear side of the horizontal tray **12** and extend into the recess **90** so that the back plane **100** is approximately flush with the rear side of the horizontal tray **12** when the back plane is in a vertical position. The mounting brackets **102a-b** each include an arcuate slot **106a-b** to allow the back plane **100** to rotate through a rotational range with respect to the mounting brackets. For example, that rotational range is approximately 30 degrees in the configuration shown in FIGS. 6A-B. Clutch assemblies **46a-b** at the connections between the mounting brackets **102a-b** the back plane **100** support the back plane **100**, with an associated docking station **18** and computer terminal **20**, in virtually any rotational orientation within the rotational range defined by the slots **106a-b**.

[0088] FIG. 7A is an exploded view the mounting brackets **102a-b** and the clutch assemblies **46a-b**. Referring to the clutch assembly **46b** for illustration purposes, this assembly includes two identical connection assemblies **110a-b**. Referring now to the connection assembly **110a** for illustration purposes, this assembly includes a threaded standoff **112** including a collar that passes through a hole in the support frame **114** of the back plane **100** and a rim that catches on the support frame. The threaded standoff **112** is preferably press-fitted into the hole in the support frame **114**.

[0089] The connection assembly **110a** also includes a nylon shoulder washer **116** including a collar that passes through a hole in the mounting bracket **44b** and a rim that catches on the mounting bracket. The collar of nylon shoulder washer **116** is sized to snugly receive the threaded standoff **112**. The connection assembly **110a** also includes a nylon washer **118**, two steel washers **120** and **122**, and a steel spring washer **124** positioned for compression between the steel washers. A bolt **126** passes through these washers and screws into the threaded standoff **112**. The bolt **126** may be tightened into the threaded standoff **112** to compress the steel spring washer **124** and provide a desired amount of resistance in the connection assembly **110a**.

[0090] FIG. 7B is a side view of the spring washer **124**, and FIG. 7C is a perspective view of the spring washer. These figures show that the spring washer **124** has a slight conical shape that is raised in the middle with respect to the outer perimeter. This type of spring washer provides a compact and inexpensive mechanism for imparting an adjustable amount of resistance in the connection assembly **110a**. Those skilled in the art will appreciate that other types of clutch assemblies could be employed in embodiments of the invention.

[0091] Another embodiment of a mobile workstation is shown in FIG. 8 illustrates a mobile workstation **210** in a typical environment, such as a patient's hospital room **205**. The mobile workstation **210** includes an adjustable-height horizontal tray **212** supported by a chassis **214**. The chassis **214** includes a dolly assembly **216** that allows an operator, such as a medical practitioner, to easily push the mobile

workstation **210** from place to place. The horizontal tray **212** includes an underside tray housing **218**, an underside front mounting bracket **220**, and an underside back mounting bracket **222** or wiring tray.

[0092] The tray housing **218** supports a keyboard (not shown) or keypad for a wireless computer terminal (not shown). The wireless computer terminal mounts within the front mounting bracket **220**. The back mounting bracket **222** or wiring tray supports a power converter (not shown) supplying power to the wireless computer terminal. A tiltable display screen **224** attaches to the top of the horizontal tray **212** while connecting to the wireless computer terminal. The back mounting bracket **222** or wiring tray can also support additional power converters for the display screen **224** or for other electrical devices associated with the mobile workstation **210**.

[0093] The chassis **214** includes a vertical beam **226** connecting the horizontal tray **212** to the dolly assembly **216**. The vertical beam **226** includes a gas-spring height adjustment mechanism (not shown) and a release lever **228** for adjusting the length of the beam **226** and, thus, the height of the horizontal tray **212** above the dolly assembly **216**. For example, the chassis **214** may be a model MPC2001 manufactured by JACO, Inc. with the standard tray replaced by the horizontal tray **212** shown in FIG. 8. Those skilled in the art will appreciate that other types of wheeled chassis would be suitable for this purpose. In addition, other types of height adjustment mechanisms would also be suitable, such as a rack and pinion mechanism, a cable and pulley mechanism, a ratchet mechanism, a ball screw mechanism, a removable pin and holes arrangement, and so forth. Nevertheless, a gas-spring height adjustment mechanism **228** is preferred because it is easy operate and ergonomically desirable.

[0094] The mobile workstation **210** also carries a power converter (not shown) within the back mounting bracket **222** and a power unit **230** including a battery charger, an extended-life battery, a power cord **232**, and a recoil mechanism that can retract the power cord when the cord is not in use. The power unit **230** supplies power to the wireless computer terminal through the power converter. The power unit **230** is located on the lower end of the chassis **214**. For example, the power unit **230** may reside between two metal beams in the dolly assembly **216** at the lower end of the chassis **214**. A suitable power unit **230** is a 26 Amp-Hour battery providing a regulated 10-16 Volt output at 40 watts with an automatic low power cut-off. The extended-life battery may be a 12-Volt sealed lead acid battery, and the battery charger may be a 120-Volt AC to 16-Volt DC converter.

[0095] The power unit **230** typically includes a first status-indicator light to inform the user when the unit is operating off of AC power, a second status-indicator light to inform the user when the battery needs recharging, and a seven-level battery status-indicator light. The power unit **230** may also include a sound indicator that beeps to inform the user when the extended-life battery needs recharging. When plugged into an AC outlet, the battery charger will charge both the extended-life battery and operate the wireless computer terminal by supplying the power converter connected to the computer terminal. The extended-life battery can be recharged by plugging the power cord **232** into a standard 120-volt AC outlet. When not in use, the recoil mechanism can retract the power cord **232** into the power unit **230**.

[0096] The wireless computer terminal inside the mobile workstation **210** communicates through a radio transmitter/receiver terminal antenna **234** attached to the top of the horizontal tray **212**. The terminal antenna **234** is operable for communicating over an approved radio frequency. A suitable radio transmitter/receiver to mount to the wireless computer terminal is a Lucent Extended 802.11 radio with a cable for using an external antenna. A suitable terminal antenna **234** for mounting to the horizontal tray **212** is a whip antenna used in DOS VMT products (1380/1390, 1320/1330). In particular, the wireless computer terminal may establish a radio-frequency communication channel **236** with a distributed patient-care computer network **238** through an antenna **240** connected to a network access point **242**. This network access point **242** is typically located in an enclosure **244** located above the ceiling of the hospital room. The network access point **242**, in turn, allows the wireless computer terminal to communicate with the distributed patient-care computer network **238**. For example, the network access point **242** may be a RANGELAN2 7500 Series Access Point manufactured by PROXIM, INC. of Mountain View, Calif.

[0097] FIGS. 9A-9D are a series of side views of the mobile workstation **210** illustrating the operation of an adjustable-height horizontal tray **212** and the display screen **224**. FIG. 9A shows the mobile workstation **210** with the height-adjustable horizontal tray **212** in a vertically lowered position. To raise the tray **212**, the operator places his or her hand through an access opening **246** in the side of the tray housing **218**. The operator then lifts the release lever **228**, which releases a stop in the gas-spring height adjustment mechanism (not shown) in the vertical beam **226**. The operator then raises or lowers the horizontal tray **212** while holding the release lever **228** in a raised position.

[0098] Assistance provided by the gas-spring height adjustment mechanism allows the operator to change the height of the horizontal tray **212** with little effort. Once the horizontal tray **212** is at a desired height, represented by the height shown in FIG. 9B, the operator releases the lever **228**, which locks the tray **212** at the desired height. With this type of mechanism, the operator can quickly and easily place the horizontal tray **212** at virtually any height within the adjustment range of the gas-spring height adjustment mechanism. The assistance provided by the gas-spring height adjustment is ergonomically desirable in that it avoids back strain or other lifting problems that could otherwise be encountered by operators using the mobile workstation **210**.

[0099] FIG. 9C illustrates the mobile workstation **210** with the display screen **224** in a vertical position. A tiltable bracket **248** attaches the display screen **224** to the horizontal tray **212**. The tiltable bracket **248** maintains the display screen **224** in a number of selectable rotational positions relative to the tray **212** so that the display screen **224** is in front of users for ease of visibility. The rotational range of the tiltable bracket **248** is preferably about 30 degrees rearward from vertical. That is, the tiltable bracket **248** preferably allows the display screen **224** to be rotated from the position shown in FIG. 9C to the position shown in FIG. 9D. The tiltable bracket **248** could also be configured to allow the display screen **224** to rotate forward through a similar rotational range.

[0100] It should be understood that the term "substantially vertical" may include a range about a strictly vertical

orientation, represented by the 30 degree range illustrated by FIGS. 9C-9D. For example, the term "substantially vertical" includes configurations in which the bracket **248** maintains the display screen **224** in a strictly vertical orientation, or at a fixed rotational orientation with a vertical component, or within a range of rotational orientations including orientations that include vertical components. Alternatively, the display screen **224** could be supported in a substantially horizontal position, for example by a drawer or pull-out tray located above or under the horizontal tray **212**. Other locations for the display screen **224** may be preferred in certain environments. For example, the display screen **224** could be mounted to the side of the horizontal tray **212**, to the underside of the horizontal tray **212**, to the dolly assembly **216**, to the vertical beam **226**, and so forth.

[0101] The tiltable bracket **248** imparts sufficient rotational resistance to maintain the display screen **224**, with an associated computer terminal (not shown), at any of the rotational aspects within the rotational range defined by the tiltable bracket **248**. At the same time, the rotational resistance imparted by the tiltable bracket **248** is pliant enough to allow the operator to change the rotational orientation of the display screen **224** with one hand. For example, the operator may easily adjust the angle of the display screen **224** to avoid glare on the display screen **224**. A clutch mechanism similar to that discussed with reference to FIG. 7 may be used to allow selective rotation of the display screen **224**.

[0102] FIGS. 10A-10B are perspective views of the mobile workstation **210** showing the operation of a pull-out keyboard tray **250**, which is supported by the tray housing **218** attached to the underside of the horizontal tray **212**. The pull-out keyboard tray **250** slides from an inner position, shown in FIG. 10A, to an outer position, shown in FIG. 10B, along conventional rollers (not shown) within a conventional roller guide slots (not shown). Typically, rollers mounted to the bottom side of the keyboard tray **250** fit within roller guide slots attached to the top side of the tray housing **218**. A keyboard (not shown) fits within the pull-out keyboard tray **250**. The pull-out keyboard tray **250** is to detent when fully extended away from the front edge of the tray housing **218**, permitting the operator to type on the keyboard without the keyboard tray **250** sliding back into the tray housing **218**. When the pull-out keyboard tray **250** is in the retracted position, the keyboard tray **250** will not slide out during movement or transport of the mobile workstation **210**.

[0103] As shown in FIG. 10B, the pull-out keyboard tray **250** can be extended outward from the front end of the tray housing **218**. The rollers on the bottom of the pull-out keyboard tray **250** permit the pull-out tray **250** to roll forward within the roller guide slots along the length of the top side of the tray housing **218**. The roller guide slots have a physical stop at the front end of the tray housing **218**. When a roller makes contact with the physical stop at the front end of the tray housing **218**, the pull-out keyboard tray **250** cannot be extended any further from the front edge of the tray housing **218**.

[0104] In FIGS. 10A-10B, the top portion of a rectangular cover for the vertical beam **226** has been removed, showing an underlying shaft **252** and a power cable **254** connecting the power unit **230** to the power converter (not shown). This shaft **252** connects to the gas-spring height adjustment

mechanism 256 that allows adjustment of the height of the horizontal tray 212. The gas-spring height adjustment mechanism 256, which is located at the bottom of the vertical beam 226, sits on top of the dolly assembly 216. This dolly assembly includes an arched cross-beam 258 that connects to two horizontal runner beams 260a-b. Two casters, represented by the caster 262, are connected to the bottom sides of each horizontal runner beam 260a-b. For example, a suitable size caster is a conventional 5" caster. The power unit 230 is mounted below the arched cross beam 258 with a support bracket 264, which connects between the horizontal runner beams 260a-b.

[0105] FIGS. 10A-10B also show that the top side 266 of the horizontal tray 212 defines a substantially horizontal work surface. The tiltable bracket 248 supports the display screen 224 so that the elongate dimension 268 is substantially vertical and the relatively slender dimension 270 is substantially horizontal. Because the display screen 224 is vertically mounted, the display screen 224 does not occupy a substantial portion of the top surface 266 of the horizontal tray 212, which allows this area to be used as a work surface. It will be understood that the term "substantially vertical" includes a range of orientations because the display screen 224 may rotate through a rotational range about a strictly perpendicular orientation.

[0106] FIG. 11A is a side view of the horizontal tray 212 and the attached tray housing 218 showing the access opening 246 and the release lever 228 for raising and lowering the horizontal tray 212. The release lever 228 operates the gas-spring height adjustment mechanism 256 previously shown in FIGS. 10A-10B. The access opening 246 in the side wall of the tray housing 218 provides convenient operator access to actuate the release lever 228.

[0107] FIG. 11B is a perspective view of the horizontal tray 212 showing the access opening 246 and the release lever 228 for raising and lowering the horizontal tray 212. Typically, the release lever 228 has a tee or a paddle on the end, so that an operator can conveniently actuate the release lever 228 thereby raising or lowering the gas-spring height adjustment mechanism 256.

[0108] FIG. 11B also shows the top surface 266 of the horizontal tray 212. The top surface 266 of the horizontal tray 212 is preferably constructed from a non-porous material, such as plastic or metal. For example, the horizontal tray 212 may be constructed from a flat wooden, particle board, or composite substrate covered with a plastic overlay defining the top surface 266. The plastic overlay may be created with an injection mold, and then glued to the substrate. Those skilled in the art will appreciate that other types of horizontal trays could be employed in embodiments of the invention.

[0109] FIGS. 12A-12C are a series of detailed views of the mobile workstation 210 of FIG. 8, with the display screen 224, a keyboard 272, a wireless computer terminal 274, and a power unit 230. FIG. 12A is a perspective view of the mobile workstation 210 illustrated in FIG. 8. FIG. 12B is a side view of the mobile workstation 210 illustrated in FIG. 12A. FIG. 12C is a front view of the mobile workstation 210 illustrated in FIG. 12A.

[0110] In FIG. 12A, the mobile workstation 210 is shown with a display screen 224 mounted to the top surface of the

horizontal tray 212. A tiltable bracket 248 connects the display screen 224 to the top of the horizontal tray 212. Conventional electrical connections (not shown) provide an interface between the wireless computer terminal 274 and the display screen 224. A suitable display screen 224 is a flat panel LCD with a 14-15" TFT viewable screen, a minimum video resolution of 1024x768 pixels, a minimum 200 nit, and a DC power input. Those skilled in the art will appreciate that other types of display screens could be employed in embodiments of the invention, including those having touch performance screens.

[0111] As shown in FIG. 12B, a front mounting bracket 220 mounts to the bottom side 278 of the horizontal tray 212, and holds the computer terminal 274 substantially parallel to the bottom side 278 of the front portion of the horizontal tray 212. The front mounting bracket 220 is sized to support the wireless computer terminal 274, such as a laptop computer, within the front bracket 220 and adjacent to the bottom side of the horizontal tray 212. The front mounting bracket 220 has an access window 280 in the side wall for operator access to various ports or interfaces in the side of the wireless computer terminal 274.

[0112] The wireless computer terminal 274 may include a communication interface, such as an optical interface or a conventional electrical connection, for communicating data between the computer terminal 274 and the keyboard 272. The communication interface between the keyboard 272 and the computer terminal 274 allow the keyboard 272 to communicate keystrokes to the computer terminal 274. This type of operation permits an operator to easily remove the computer terminal 274 from the front mounting bracket 220, or to remove the keyboard 272 from the keyboard tray 250. As previously described in FIG. 8, the wireless computer terminal 274 can then send signals through the terminal antenna 234 attached to the top surface 266 of the horizontal tray 212 to communicate with a remote computer network (shown in FIG. 8 as 238) via a radio frequency communication channel (shown in FIG. 8 as 236).

[0113] A suitable wireless computer terminal is an Orion PC manufactured by Netier Technologies. The variety of computer terminal models offered under the Orion PC family includes a "Thin Client" configuration, or a "Fat" system. For example, the "Fat" system comprises an ACD-MSX-100 base unit with a Pentium 266 MHz microprocessor on a Socket 7 motherboard operating a MICROSOFT Windows 95 operating system, 32-128 MB RAM, 2 MB Video RAM, 2 GB hard disk, two Type II PCMCIA slots, one Type III PCMCIA slot, one parallel port, one serial port, one video port, one LCD port, dual USB ports, one PS/2 keyboard/mouse port, one IrDa port, and one battery module. Optional accessories for the Orion PC family include an automobile cigarette lighter charger/adaptor, and AC charger/adaptor, a second battery module, a floppy disk drive, and a CD-ROM or CD-R drive. Those skilled in the art will appreciate that other computer terminals can be used in conjunction with the present invention to achieve the same purpose.

[0114] Many different computer interfaces may be used to input data into the wireless computer terminal, including a keyboard, a keypad, a scanner, a serial mouse, or any other similar type of input device. A suitable keyboard for use with the wireless computer terminal is a thin Cherry keyboard

with a PS/2 interface. An optional plastic keyboard cover protects the keyboard from spills during usage. Other computer interfaces for the wireless computer terminal include a PSC Q6000 scanner with a PS/2 interface, a serial mouse, and a Y-cable to merge the keyboard and the scanner inputs.

[0115] Typically, a conventional electrical connection (not shown) between the wireless computer terminal 274 and the power converter provides an interface between the computer terminal 274 and the power converter. Conventional electrical connections such as an automobile adaptor plug, or a touch-pin battery charging terminal can be used with a wireless computer terminal 274 to provide an interface with the power converter within the back mounting bracket 222. The power converter, in turn, is connected to the power unit 230 by the power cable (shown in FIG. 10A as 254). The power unit 230 can then be plugged into a standard 120 Volt AC outlet with the power cord 232.

[0116] The back mounting bracket 222 or wiring tray also mounts to the bottom side 278 of the horizontal tray 212. The back mounting bracket 222 or wiring tray supports the power converter substantially parallel to and adjacent to the bottom side 278 of the horizontal tray 212. The power converter is supported within the sidewalls of the back mounting bracket 222, which can further support cables (not shown) for other devices connected to the computer terminal 274, such as a mouse, keypad, or other similar devices, or support other power converters for other electrical devices associated with the mobile workstation 210. A series of ventilation holes 282 machined in the sidewall of the back mounting bracket 222 assist in venting heat away from the power converter mounted within the back bracket 222.

[0117] The tray housing 218 is also attached the bottom side 278 of the horizontal tray 212. The tray housing 218 is sized to fit over the front mounting bracket 220 and the back mounting bracket 222 leaving sufficient clearance between the topside of the tray housing 218 and both the front bracket 220 and the back bracket 222. Sufficient clearance between the tray housing 218 and the front mounting bracket 220 permits the installation of a keyboard 272 or keypad within the pull-out keyboard tray 250 in the tray housing 218, so that the keyboard 272 does not interfere with the bottom of the front mounting bracket 220 when the pull-out keyboard tray 250 is fully retracted within the tray housing 218 as shown.

[0118] The access opening 246 in the side wall of the tray housing 218 permits operator access to various ports or interfaces on the side of the wireless computer terminal 274 through the access window 280 of the front mounting bracket 220. The size of the access opening 246 also permits operator access to actuate the release lever 228 of the gas spring height adjustment mechanism (shown in FIG. 10A as 256) to raise or lower the height of the mobile workstation 210 as shown in FIGS. 9A-9B and FIGS. 11A-11B.

[0119] FIG. 12B shows the pull-out keyboard tray 250 in a retracted position within the tray housing 218. The display screen 224 of the mobile workstation 210 is shown in a substantially vertical orientation to the horizontal tray 212. In this configuration, an operator can transport the mobile workstation 210 from one area to another area, or use the top surface 266 of the horizontal tray 212 as a work surface. The length 284 of the horizontal runner beams 260a-b is approximately 21.3 inches.

[0120] FIG. 12C shows a front view of the mobile workstation 210 in FIG. 12A. The computer terminal 274 is shown mounted within the front mounting bracket 220 and above the keyboard 272 mounted within the pull-out keyboard tray 250. The height 286 from the top surface 266 of the horizontal tray 212 to the floor is approximately 38.6 inches when the tray 212 is in the lowermost position. The height 288 from the top edge of the display screen 224 in a fully vertical orientation to the floor is approximately 54.5 inches when the tray 212 is in the lowermost position. The width 290 between the outboard ends of the horizontal runner beams 260a-b is approximately 21.4 inches. Other heights 286, 288 for the horizontal tray 212 and the display screen 224 can be attained when the mobile workstation is adjusted for ease of accessibility and visibility.

[0121] FIGS. 13A-13D illustrate a series of views of the horizontal tray 212 of the mobile workstation 210 of FIG. 8 with an attached tray housing 218, front mounting bracket 220, back mounting bracket 222, and pull-out keyboard tray 250. FIG. 13A shows a perspective view of the horizontal tray 212 shown in FIG. 8, with an attached tray housing 218 extending from the bottom side of the horizontal tray 212.

[0122] FIG. 13B shows the top view of the horizontal tray 212. The top surface of the horizontal tray 212 is rectangular in shape with rounded edges at the front side 292, the left side 294, and right side 296. The rear side 298 of the horizontal tray 212 has a square edge. The width 300 of the horizontal tray 212 from the left side 294 to the right side 296 is approximately 18.0 inches. The depth 302 of the horizontal tray 212 from the front edge 292 to the rear edge 298 is approximately 19.4 inches. A series of four mounting holes 304a-d is machined into the rear portion of the top surface 266 of the horizontal tray 212 to correspond with a set of mounting bolts (not shown) used to secure the base of the tiltable bracket (shown in FIGS. 12A-12C as 248) to the top surface 266 of the horizontal tray 212. A first hole 306 in the left rear portion of the top surface 266 of the horizontal tray 212 provides access for the display screen cables (not shown) to extend from the display screen 224 to the computer terminal 274 underneath the horizontal tray 212. A second hole 308 machined in the left rear portion of the horizontal tray 212 provides a mount for the terminal antenna 234 permitting the wireless computer terminal 274 to communicate with a computer network (shown in FIG. 8 as 238) via radio frequency communication channel (shown in FIG. 8 as 236).

[0123] FIG. 13C shows the front view of the horizontal tray 212 shown in FIG. 13A, with a wireless computer terminal 274 within the front mounting bracket 220, and a keyboard 272 within the pull-out keyboard tray 250 mounted to the tray housing 218. Each side wall 310a-b of the tray housing 218 curves inward at the top portion of the side wall providing a mounting lip 312a-b to attach the tray housing 218 to the bottom side 278 of the horizontal tray 212. Holes (not shown) are machined in the mounting lip 312a-b to correspond with bolts (not shown) to attach the tray housing 218 securely to the bottom side 278 of the horizontal tray 212.

[0124] A pull-out keyboard tray 250 is supported between the side walls 310a-b of the tray housing 218 and substantially parallel to the top side of the tray housing 218. The pull-out tray 250 can be extended or retracted from the front

of the tray housing 218. As described previously, conventional rollers (not shown) mounted on the bottom of the pull-out tray 250 correspond with guide slots (not shown) mounted or machined into the top side of the tray housing 218. The keyboard 272 fits within the pull-out keyboard tray 250 so that the keyboard 272 does not interfere with the front mounting bracket 220 when the pull-out keyboard tray 250 is retracted within the tray housing 218.

[0125] FIG. 13D shows a side view of the horizontal tray 212 shown in FIG. 13A, with an attached tray housing 218, front mounting bracket 220, back mounting bracket 222 or wiring tray, and pull-out keyboard tray 250. The front mounting bracket 220 mounts towards the front portion of the horizontal tray 212, providing operator access to the computer terminal 274 from the front edge 292 of the horizontal tray 212. The back mounting bracket 222 or wiring tray mounts towards the rear portion of the horizontal tray 212, flush with the rear edge 298 of the bottom side 278 of the horizontal tray 212. The tray housing 218 mounts near the front edge of the bottom side 278 of the horizontal tray 212, substantially overlapping the front mounting bracket 220 and partially overlapping the back mounting bracket 222. The access opening 246 in the side wall of the tray housing 218 permits operator access to the various ports or interfaces in the side of the wireless computer terminal 274 through the access window 280 of the front mounting bracket 220. The height 314 of the horizontal tray 212 with the attached tray housing 218 measured from the top surface 266 of the horizontal tray 212 to the bottom side of the tray housing 218 is approximately 4.7 inches.

[0126] FIGS. 14A-14D illustrate the details of the front mounting bracket 220 shown in FIG. 8. FIG. 14A shows a perspective view of a front mounting bracket 220. The front mounting bracket 220 is sized to receive a wireless computer terminal 274 between two side walls 316a-b and on the top surface 318 of the front bracket 220. Each side wall 316a-b of the front bracket 220 is shaped with a mounting lip 320a-b extending along the top of each side wall 316a-b for mounting the front bracket 220 to the bottom surface 278 of the horizontal tray 212. Two bolt holes 322a-d are machined through each mounting lip 320a-b to receive bolts (not shown) attaching the front bracket 220 to the bottom surface 278 of the horizontal tray 212. Access windows 324, 326 are cut into each side wall 316a-b of the front bracket 220 to permit user access to the ports or interfaces on each side of the wireless computer terminal 274. An elongated access opening 328 along the rear portion of the front bracket 220 permits user access to the ports or interfaces on the bottom of the wireless computer terminal 274. Four tongue protrusions 330a-d from the top surface 318 of the front bracket 220 position the wireless computer terminal 274 within the front bracket, between the side walls 316a-b and flush against the rear edge 132 of the front bracket 220. Two of the tongue protrusions 330b, 330d extend from and are parallel to the rear edge 332 of the front bracket 220 to prevent the wireless computer terminal 274 from extending past the rear edge 332 of the front bracket 220. The other two tongue protrusions 330a, 330d extend upward from the top surface 318 of the front bracket 220 and run parallel with the side walls 316a-b of the front bracket 220 to position the wireless computer terminal 274 between the side walls 316a-b of the front bracket 220 and towards the center portion of the front bracket 220. The tongue protrusions 330a-d are used to position the wireless computer terminal 274 within the front

bracket 220. Other types of positioning structures or methods may be used in accordance with the present invention.

[0127] FIG. 14B shows a top view of the front mounting bracket 220 in FIG. 14A. The front mounting bracket 220 can be manufactured from $\frac{1}{16}$ inch thickness sheet steel, or any other suitable material. The width 334 of the front bracket 220 measured from the interior of the left sidewall 316a to the interior of the right sidewall 316b is approximately 14.3 inches. The width 336 of the front bracket 220 measured from the outboard end of the left sidewall mounting lip 320a to the right sidewall mounting lip 320b is approximately 15.5 inches. The depth 338 of the front bracket 220 measured from the front edge 340 to the rear edge 332 is approximately 7.4 inches.

[0128] FIG. 14C shows a front view of the front mounting bracket 220 shown in FIG. 14A. The height 342 of the front mounting bracket 220 measured from the top of either mounting lip 320a-b to the bottom side 344 of the front bracket 220 is approximately 2.522 inches.

[0129] FIG. 14D shows a side view of the front mounting bracket 220 shown in FIG. 14A. The access windows 324, 326 cut into the side walls 316a-b of the front bracket 220 are sized to permit access to ports or interfaces on the sides of the wireless computer terminal (shown in FIG. 13D as 274).

[0130] FIGS. 15A-15D illustrate the details of the back mounting bracket 222 or wiring tray shown in FIG. 8. FIG. 15A shows a perspective view of a back mounting bracket 222 or wiring tray. The back mounting bracket 222 or wiring tray is sized to receive a power converter (shown within the back mounting bracket 222 in FIG. 12B as 276) between two side walls 342a-b, a rear wall 344, and the top surface 346 of the back mounting bracket 222. The back mounting bracket 222 or wiring tray can also support associated cables or other power converters associated with the mobile workstation 210. The side walls 342a-b of the back bracket 222 are shaped with a mounting lip 348a-b extending along the top of each side wall 142a-b for mounting the back bracket 222 to the bottom surface (shown in FIG. 13D as 278) of the horizontal tray (shown in FIG. 13D as 212). A single bolt hole 350a-b is machined through each curved mounting lip 348a-b to receive bolts (not shown) attaching the back mounting bracket 222 to the bottom surface 278 of the horizontal tray 212. The series of ventilation holes 282 machined into the side walls 342a-b of the back bracket 222 permit the ventilation of heat from the power converter 276 within the back bracket, allowing subsequent cooling of the power converter 276.

[0131] An access window 352 cut into the middle portion of the front edge 354 of the top surface 346 of the back bracket 222 accommodates the vertical beam (shown in FIG. 10A-10B as 226). The vertical beam 226 extends upward from the chassis 216 and fits into the access window 352.

[0132] FIG. 15B shows a top view of the back mounting bracket 222 or wiring tray shown in FIG. 15A. The back mounting bracket 222 or wiring tray can be manufactured from $\frac{1}{16}$ inch thickness sheet steel, or any other suitable material. The interior width 356 of the back bracket 222 measured from the interior of the left sidewall 342a to the interior of the right sidewall 342b is approximately 13.8 inches. The exterior width 358 of the back bracket 222

measured from the outboard end of the left sidewall **342a** mounting lip **348a** to the outboard end of the right sidewall **342b** mounting lip **348b** is approximately 15.5 inches. The depth **360** of the back bracket **222** measured from the front edge **354** of the back bracket **222** to the rear edge **362** of the back bracket **222** is approximately 7.5 inches. A series of bolt holes **364** are drilled in the top surface **346** of the back bracket **222** to mount the battery pack **276** to the back mounting bracket **222**. A corresponding series of bolts (not shown) pass through the bolt holes **364** attaching the battery pack **276** to the top surface **346** of the back bracket **222**. Other holes **365** shown in the top surface **346** of the back bracket **222** are used for tie-wraps to secure loose cables in the back mounting bracket **222** or wiring tray.

[0133] FIG. 15C shows a front view of the back mounting bracket **222** or wiring tray shown in FIG. 15A. The height **366** of the back mounting bracket **222** measured from the top of either mounting lip **348a-b** to the bottom side **368** of the back bracket **222** is approximately 2.8 inches.

[0134] FIG. 15D shows a side view of the back mounting bracket **22** in FIG. 15A. The ventilation holes **282** in the center portion of the left sidewall **342a** are selectively sized and shaped to permit sufficient ventilation of heat from the power converter **276**, resulting in the subsequent cooling of the power converter **276**.

[0135] FIG. 16 is a front perspective view of another embodiment of a mobile workstation **410**. The mobile workstation **410** includes an adjustable-height horizontal tray **412** supported by a chassis **414**. The chassis **414** includes a dolly assembly **416** that allows an operator, such as a medical practitioner, to easily push the mobile workstation **410** from place to place. The horizontal tray **412** includes an underside tray housing **418**, a mounting bracket **420**, and an underside back mounting bracket **422**.

[0136] The tray housing **418** supports a keyboard (not shown) or keypad for a wireless computer terminal (not shown) in a pull-out keyboard tray **424**. The wireless computer terminal mounts within the mounting bracket **420**. The back mounting bracket **422** supports a power converter (not shown) that converts conventional AC or battery power to suitable electrical power for the wireless computer terminal and a display screen **426**. The tiltable display screen **426** attaches to the top of the horizontal tray **412** while connecting to the wireless computer terminal. The back mounting bracket **222** can also support associated cables or other power converters associated with the mobile workstation **210**.

[0137] The chassis **414** includes a vertical beam **428** connecting the horizontal tray **412** to the dolly assembly **416**. The vertical beam **428** includes a gas-spring height adjustment mechanism (not shown) and a release lever (not shown) for adjusting the length of the beam **428** and, thus, the height of the horizontal tray **412** above the dolly assembly **416**. For example, the chassis **414** may be a chassis model previously described and shown in FIG. 8.

[0138] The mobile workstation **410** also carries a power unit **430** including a battery charger, an extended-life battery, a power cord **432**, and a recoil mechanism that can retract the power cord when the cord is not plugged into an AC outlet. The power unit **430** is located on the lower end of the chassis **414**. For example, the power unit **430** may

reside between two metal beams in the dolly assembly **416** at the lower end of the chassis **414**. A suitable power unit **430** is a 26 Amp-Hour battery providing a regulated 10-16 Volt output at 40 watts with an automatic low power cut-off. The extended-life battery may be a 12-Volt sealed lead acid battery, and the battery charger may be a 120-Volt AC to 16-Volt DC converter.

[0139] The power unit **430** typically includes a first status-indicator light to inform the user when the AC power is being supplied, a second status-indicator light to inform the user when the battery needs recharging, and a seven-level battery status-indicator light. The power unit **430** may also include a sound indicator that beeps to inform the user when the battery needs recharging. When plugged into an AC outlet, the battery charger will charge both the extended-life battery and operate the wireless computer terminal. The extended-life battery can be recharged by plugging the power cord **432** into a standard 120-volt AC outlet. When not in use, the recoil mechanism automatically recoils the power cord **432** into the power unit **430**.

[0140] The wireless computer terminal inside the mobile workstation **410** communicates through a radio transmitter/receiver terminal antenna **434** attached to the top of the horizontal tray **412**. The terminal antenna **434** is operable for communicating over an approved radio frequency. In particular, the wireless computer terminal may establish a radio-frequency communication channel with a distributed patient-care computer network as previously shown and described in FIG. 8.

[0141] FIG. 17 is a rear right side perspective view of the mobile workstation **410** in FIG. 16. A tiltable bracket **436** attaches the display screen **426** to the horizontal tray **412**. The tiltable bracket **436** maintains the display screen **426** in a number of selectable rotational positions relative to the tray **412**. The rotational range of the tiltable bracket **436** is preferably about 30 degrees rearward from vertical. That is, the tiltable bracket **436** preferably allows the display screen **426** to be rotated left to right. The tiltable bracket **436** could also be configured to allow the display screen **426** to rotate forward through a similar rotational range.

[0142] It should be understood that the term "substantially vertical" may include a range about a strictly vertical orientation, represented by a 30 degree range. For example, the term "substantially vertical" includes configurations in which the bracket **436** maintains the display screen **426** in a strictly vertical orientation, or at a fixed rotational orientation with a vertical component, or within a range of rotational orientations including orientations that include vertical components. Alternatively, the display screen **426** could be supported in a substantially horizontal position, for example by a drawer or pull-out tray located above or under the horizontal tray **412**. Other locations for the display screen **426** may be preferred in certain environments. For example, the display screen **426** could be mounted to the side of the horizontal tray **412**, to the underside of the horizontal tray **412**, to the dolly assembly **416**, to the vertical beam **428**, and so forth.

[0143] The tiltable bracket **436** imparts sufficient rotational resistance to maintain the display screen **426**, with an associated computer terminal (not shown), at any of the rotational aspects within the rotational range defined by the tiltable bracket **436**. At the same time, the rotational resis-

tance imparted by the tiltable bracket 436 is pliant enough to allow the operator to change the rotational orientation of the display screen 426 with one hand. For example, the operator may easily adjust the angle of the display screen 426 to avoid glare on the display screen 426.

[0144] FIG. 18 is a rear right side perspective view of the mobile workstation 410 in FIG. 16 with the pull-out keyboard tray 424 in the extended position. The pull-out keyboard tray 424 slides from an inner position, shown in FIGS. 16-17, to an outer position, shown in FIG. 18, along conventional rollers (not shown) within a conventional roller guide slots (not shown). Typically, rollers mounted to the bottom side of the keyboard tray 424 fit within roller guide slots attached to the top side of the tray housing 418. A keyboard (not shown) fits within the pull-out keyboard tray 424. The pull-out keyboard tray 424 is to detent when fully extended away from the front edge of the tray housing 418, permitting the operator to type on the keyboard without the keyboard tray 424 sliding back into the tray housing 418. When the pull-out keyboard tray 424 is in the retracted position, the keyboard tray 424 will not slide out during movement or transport of the mobile workstation 410.

[0145] As shown in FIG. 18, the pull-out keyboard tray 424 can be extended outward from the front end of the tray housing 418. The rollers on the bottom of the pull-out keyboard tray 424 permit the pull-out tray 424 to roll forward within the roller guide slots along the length of the top side of the tray housing 418. The roller guide slots have a physical stop at the front end of the tray housing 418. When a roller makes contact with the physical stop at the front end of the tray housing 418, the pull-out keyboard tray 424 cannot be extended any further from the front edge of the tray housing 418.

[0146] FIG. 19 is a front right side perspective view of the mobile workstation 410 in FIG. 16 with the pull-out keyboard tray 424 in the extended position. The top portion of a rectangular cover for the vertical beam 428 has been removed, showing an underlying shaft 438 and a power cable 440 connecting the power unit 430 to the power converter (not shown). This shaft 438 connects to the gas-spring height adjustment mechanism (not shown) that allows adjustment of the height of the horizontal tray 412. The gas-spring height adjustment mechanism, which is located at the bottom of the vertical beam 428, sits on top of the dolly assembly 416. This dolly assembly 416 includes an arched cross-beam 442 that connects to two horizontal runner beams 444a-b. Two casters, represented by the caster 446, are connected to the bottom sides of each horizontal runner beam 444a-b. For example, a suitable size caster is a conventional 5" caster. The power unit 430 is mounted below the arched cross beam 442 with a support bracket 448, which connects between the horizontal runner beams 444a-b.

[0147] FIG. 20 is a side view of the mobile workstation 410 shown in FIG. 16. The mounting bracket 420 attaches to the top surface of the horizontal tray 412 permitting a wireless computer terminal (not shown) to be stored on the top of the horizontal tray 412. The tiltable bracket 436, supporting the display screen 426, mounts to the top surface of the mounting bracket 420. A touch-pin display interface (not shown) located on the back of the wireless computer terminal provides an interface between the computer terminal and the display screen 426.

[0148] The tray housing 418 mounts to the underside of the horizontal tray 412. The pull-out keyboard tray 424 supporting a keyboard (not shown), mounts to the front portion of the top surface of the tray housing 418. The wireless computer terminal may include a communication interface, such as an optical interface, for communicating data between the computer terminal and the keyboard. A conventional electrical connection allows the keyboard to communicate keystrokes to the computer terminal. This type of operation permits an operator to easily remove the computer terminal from the mounting bracket 420, or to remove the keyboard from the pull-out keyboard tray 424.

[0149] The back mounting bracket 422 or wiring tray attaches to the rear portion of the underside of the horizontal tray 412. The back mounting bracket 422 or wiring tray supports the power converter (not shown) for supplying power to the wireless computer terminal. A touch-pin battery charging terminal (not shown) or other conventional electrical connection, such as an automobile adaptor plug, located on the back of the wireless computer terminal provides an interface between the computer terminal and the power converter within the back mounting bracket 422. The power converter, in turn, is connected to the power unit 430 by the power cable (shown in FIG. 19 as 440). The power unit 430 can then be plugged into a standard 120 Volt AC outlet with the power cord 432.

[0150] An access opening 450 in the side of the tray housing permits operator access to actuate a release lever 452 for raising and lowering the horizontal tray 412. The release lever 452 operates the gas-spring height adjustment mechanism (not shown). Typically, the release lever 452 has a tee or a paddle on the end, so that an operator can conveniently actuate the release lever 452 thereby raising or lowering the gas-spring height adjustment mechanism.

[0151] In view of the foregoing, it will be appreciated that the invention provides a mobile workstation that includes an adjustable-height horizontal tray and a vertically-mounted docking station mounted to the horizontal tray. The mobile workstation also carries a power converter and a power unit including a battery charger and an extended-life battery for a wireless computer terminal stored within the docking station. It will also be appreciated that the invention provides a mobile workstation that includes an adjustable-height horizontal tray mounted on a chassis, a vertically-mounted display screen mounted to the horizontal tray, a wireless computer terminal and battery converter mounted to the horizontal tray, a pull-out keyboard tray mounted beneath the computer terminal, and a power unit mounted to the chassis. The power unit also includes a battery charger and an extended-life battery for the wireless computer terminal.

[0152] FIG. 21 shows another embodiment of a mobile workstation 500. The mobile workstation 500 may be similar to the mobile workstation 410 or the other mobile workstations described above. The mobile workstation 500 may include a patient vital signs capture device 510. The patient vital signs capture device 510 may include a monitor/control device 520 and a sensor device 530. The monitor/control device 520 includes a data display. The sensor device 530 may be a blood pressure cuff or a similar type of device. Other types of sensors 530 may include thermometry sensor, a pulse oximetry sensor, and similar types of devices. Through the use of these and similar sensors 530, the patient

vital signs capture device **510** may be able to capture a patient's electrocardiogram, blood pressure (NiBP), SP02 (blood oxygen saturation), pulse, temperature, and the like. The patient vital signs capture device **510** may be a Vital Signs Monitor 300 series sold by Welch Allyn of Beaverton, Oreg. or similar types of devices. Any type of medical monitoring device may be used herein.

[0153] By integrating the patient vital signs capture device **510** with the mobile workstation **500**, the capture of real time vitals data into the electronic medical record is possible. Double entries and lag time thus may be largely eliminated. The vital signs capture device **510** also may be used without the computer terminal as may be desired. Rather, the vital signs capture device **510** may establish a radio-frequency communication channel with a distributed patient-care computer network through an antenna or other type of radio transceiver connected to a network access point.

[0154] FIG. 22 shows a further embodiment of a mobile workstation **550**. The mobile workstation **550** may be similar to the mobile workstation **410** or the other mobile workstations described above. In this embodiment, the mobile workstation **550** includes a videoconferencing system **560**. The videoconferencing system **560** may include an extra large monitor or screen as described above or it may include a dual screen **570** as is shown. The dual screen **570** thus allows the use of two high resolution imaging displays. As such, diagnostic images, electronic medical records (EMR), or other patient data may be shared. A video camera **580** also may be used.

[0155] The videoconferencing system **560** as a whole thus offers interaction with remote experts or others while simultaneously reviewing the patient's chart and images. Specifically, remote experts can be consulted and provide advice with easy access to up to date patient information and vitals.

[0156] It should be understood that the foregoing relates only to the exemplary embodiments of the present invention, and that numerous changes may be made therein without departing from the spirit and scope of the invention as defined by the following claims.

The invention claimed is:

1. A mobile workstation for use with a computer network, comprising:

a medical monitoring device;

a radio transceiver in communication with the medical monitoring device operable for receiving and sending data to the computer network;

a display screen; and

a wheeled chassis for mounting the medical monitoring device, the radio transceiver, and the display screen.

2. The mobile workstation of claim 1, further comprising a computing device positioned on the wheeled chassis and in communication with the medical monitoring device.

3. The mobile workstation of claim 1, further comprising a power supply positioned on the wheeled chassis.

4. The mobile workstation of claim 1, wherein the medical monitoring device comprises a vital signs capture device.

5. The mobile workstation of claim 4, wherein the vital signs capture device comprises a monitor/control device.

6. The mobile workstation of claim 4, wherein the vital signs capture device comprises a sensor.

7. The mobile workstation of claim 6, wherein the sensor comprises a blood pressure cuff.

8. The mobile workstation of claim 6, wherein the sensor comprises a thermometry sensor.

9. The mobile workstation of claim 6, wherein the sensor comprises a pulse oximetry sensor.

10. The mobile workstation of claim 1, further comprising a videoconferencing system.

11. A mobile workstation for use with a computer network, comprising:

a videoconferencing system;

a radio transceiver in communication with the videoconferencing system operable for receiving and sending data to the computer network; and

a wheeled chassis for mounting the videoconferencing system and the radio transceiver.

12. The mobile workstation of claim 11, further comprising a computing device positioned on the wheeled chassis and in communication with the medical monitoring device.

13. The mobile workstation of claim 11, further comprising a power supply positioned on the wheeled chassis.

14. The mobile workstation of claim 11, wherein the videoconferencing system comprises a video screen.

15. The mobile workstation of claim 11, wherein the videoconferencing system comprises a dual video screen.

16. The mobile workstation of claim 11, wherein the videoconferencing system comprises a diagnostic image.

17. The mobile workstation of claim 11, wherein the videoconferencing system comprises electronic medical records.

18. The mobile workstation of claim 11, wherein the videoconferencing system comprises a video camera.

19. The mobile workstation of claim 11, further comprising a vital signs capture device positioned on the wheeled chassis.

20. A method of using a mobile workstation, comprising:

rolling the mobile workstation about a patient;

viewing the patient's electronic medical records on the mobile workstation; and

conferencing with a third party via the mobile workstation.

* * * * *

专利名称(译)	移动临床工作站		
公开(公告)号	US20070055116A1	公开(公告)日	2007-03-08
申请号	US11/358164	申请日	2006-02-21
[标]申请(专利权)人(译)	CLARK理查德 JACOBS迈克尔 - [R FLEMIG史蒂芬乙 ABU AKEL福阿德 JANOSCHKA DARIN 本报讯KEITH		
申请(专利权)人(译)	CLARK理查德 JACOBS迈克尔 - [R FLEMIG史蒂芬乙 ABU-AKEL福阿德 JANOSCHKA DARIN 本报讯KEITH		
当前申请(专利权)人(译)	CLARK理查德 JACOBS迈克尔 - [R FLEMIG史蒂芬乙 ABU-AKEL福阿德 JANOSCHKA DARIN 本报讯KEITH		
[标]发明人	CLARK RICHARD A JACOBS MICHAEL R FLEMIG STEVEN B ABU AKEL FOUAD JANOSCHKA DARIN WASHINGTON KEITH		
发明人	CLARK, RICHARD A. JACOBS, MICHAEL R. FLEMIG, STEVEN B. ABU-AKEL, FOUAD JANOSCHKA, DARIN WASHINGTON, KEITH		
IPC分类号	A61B5/00		
CPC分类号	A61B5/0002 G06F19/3418 Y10S248/918 G06F1/166 G06F1/1632 G16H40/67 G06F1/1635 G06F1/1637 G06F1/1662 G06F1/1686 G06F1/26 H02J7/0045		
其他公开文献	US7612999		
外部链接	Espacenet USPTO		

摘要(译)

用于计算机网络的移动工作站。移动工作站可以包括医疗监控设备，与医疗监控设备通信的无线电收发器，可操作于接收和发送数据到计算机网络，显示屏和用于安装医疗监控设备的轮式机箱，无线电收发器和显示屏。

