



(19) **United States**

(12) **Patent Application Publication**

(10) **Pub. No.: US 2002/0077672 A1**

Govari et al.

(43) **Pub. Date:**

Jun. 20, 2002

(54) **TELEMETRIC READER/CHARGER DEVICE FOR MEDICAL SENSOR**

(52) **U.S. Cl. 607/60**

(76) **Inventors: Assaf Govari, Haifa (IL); Shlomo Ben-Haim, Haifa (IL); Joel Zilberstein, Haifa (IL)**

(57) **ABSTRACT**

Correspondence Address:
Philip S. Johnson, Esq.
Johnson & Johnson
One Johnson & Johnson Plaza
New Brunswick, NJ 08933-7003 (US)

A signal reading and charging device for use with an implantable telemetric medical sensor comprises a casing and a circuit within the casing comprising a logic control unit and a processing unit. The logic control unit sends a powering signal to the telemetric medical sensor for remotely powering the sensor. The logic control unit also receives a transmitted signal from the sensor. The processing unit is operatively connected to the control unit for converting the transmitted signal by the sensor into a measured parameter. An antenna coil is used for sending the powering signal and receiving the transmitted signal from the sensor. The device also includes a display for displaying the measured parameter.

(21) **Appl. No.: 09/739,575**

(22) **Filed: Dec. 18, 2000**

Publication Classification

(51) **Int. Cl.⁷ A61N 1/08**

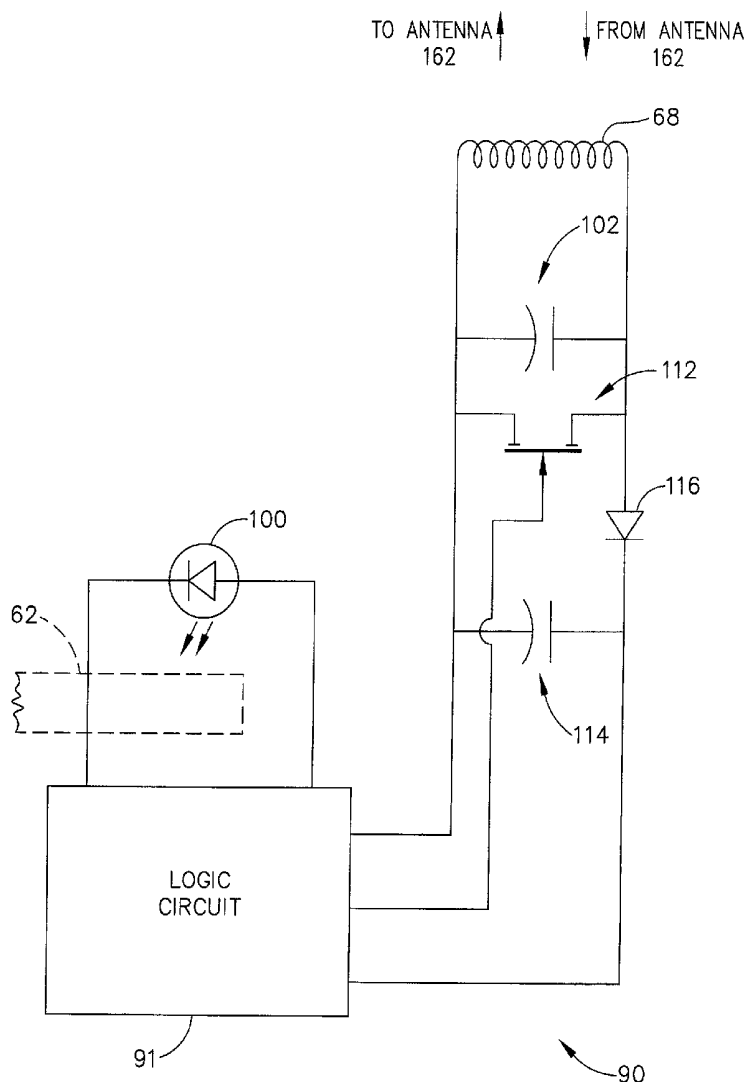

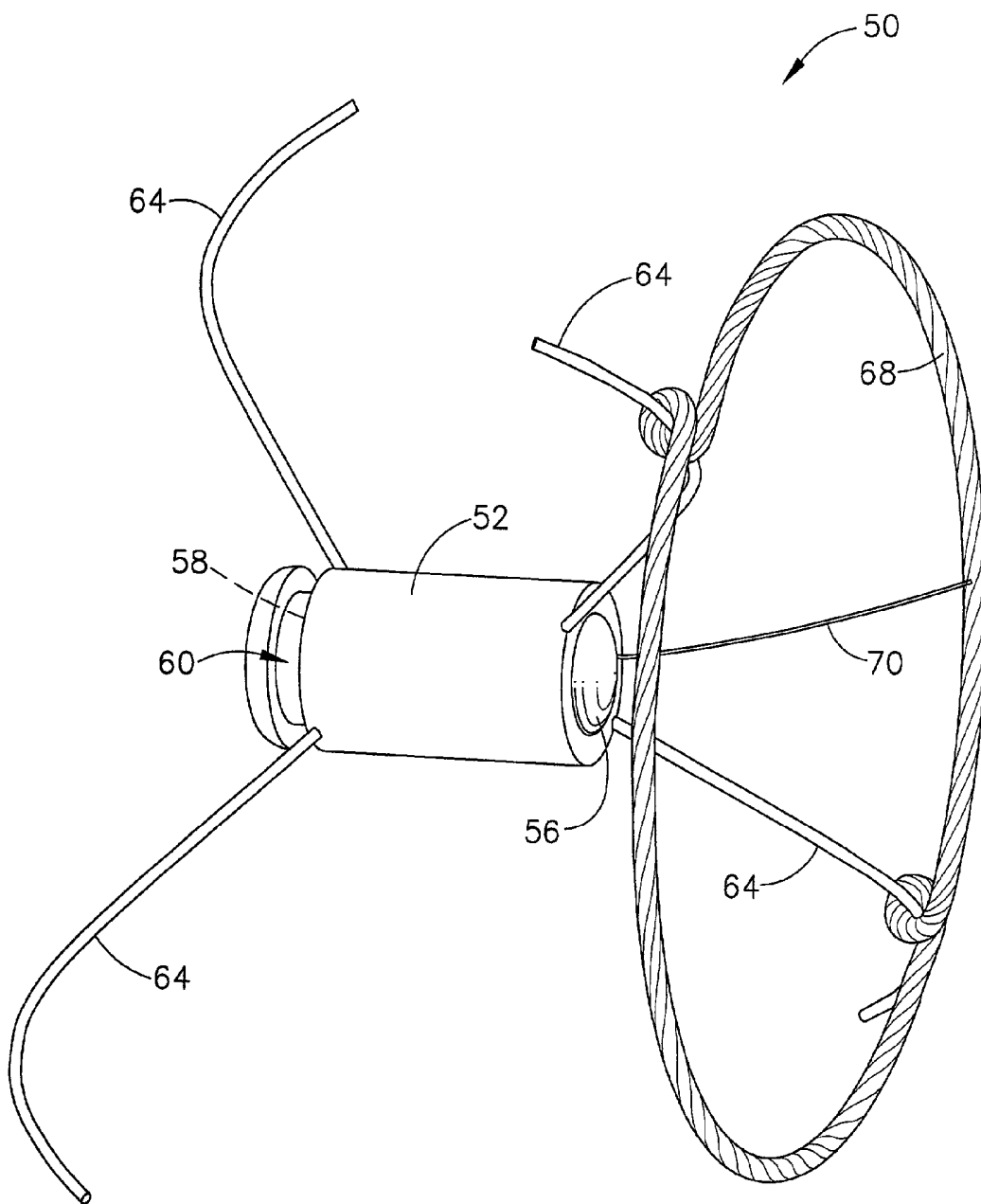

FIG. 1

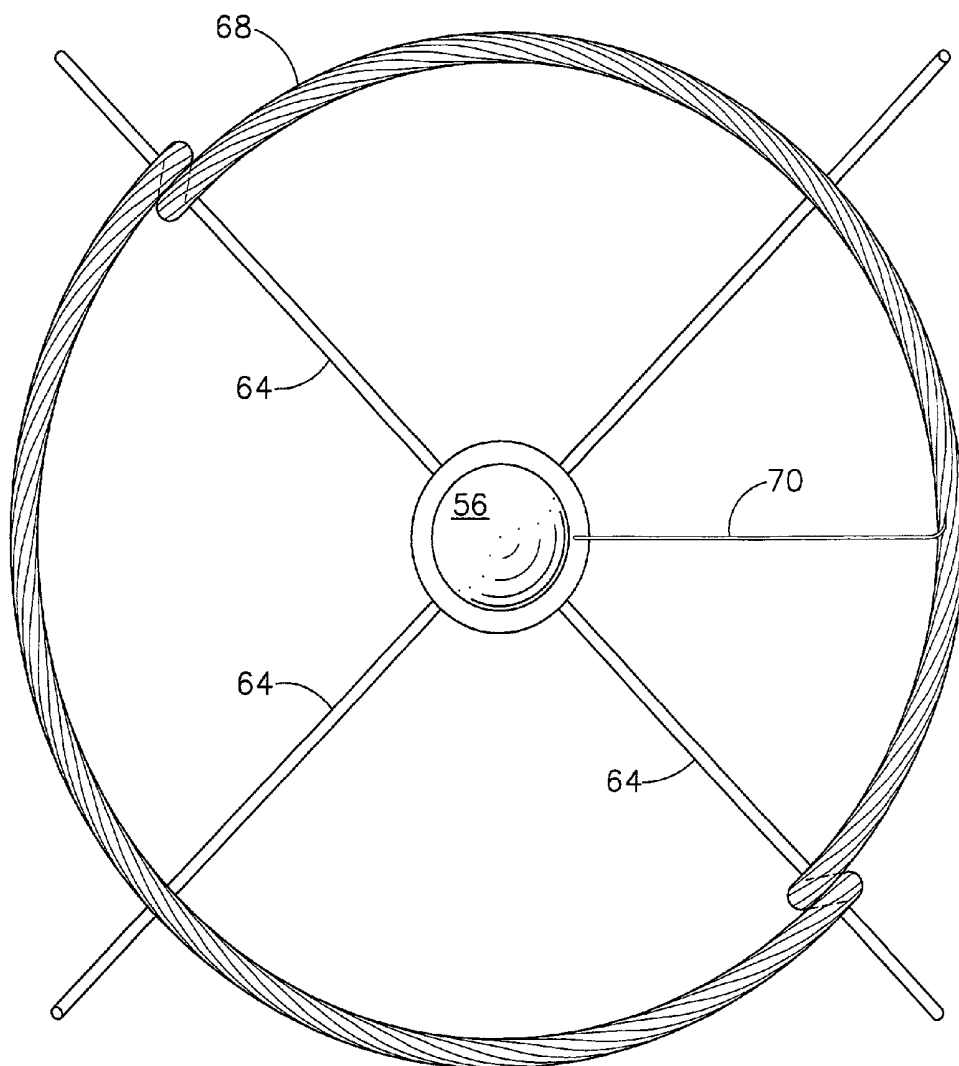

FIG. 2

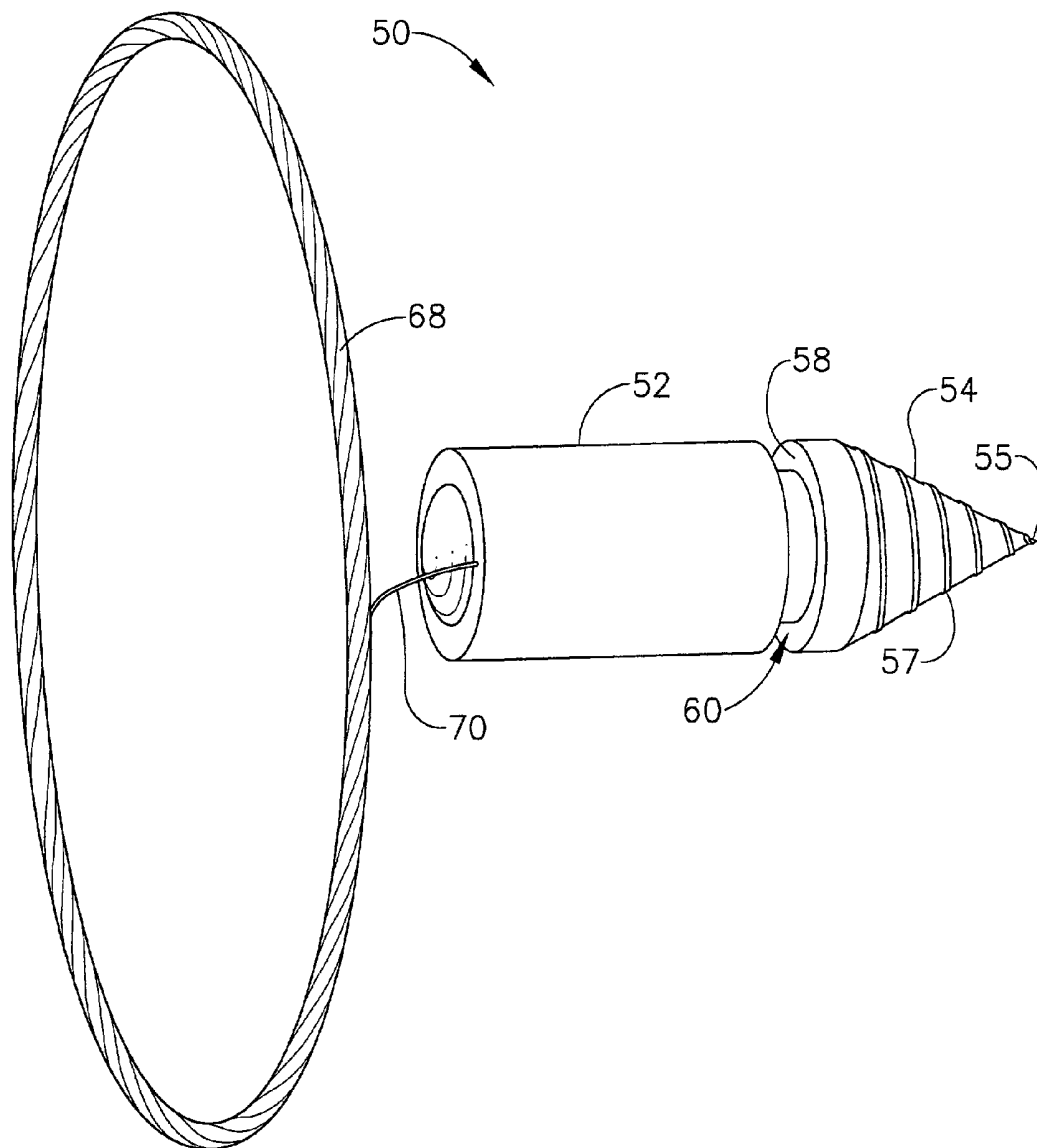

FIG. 3

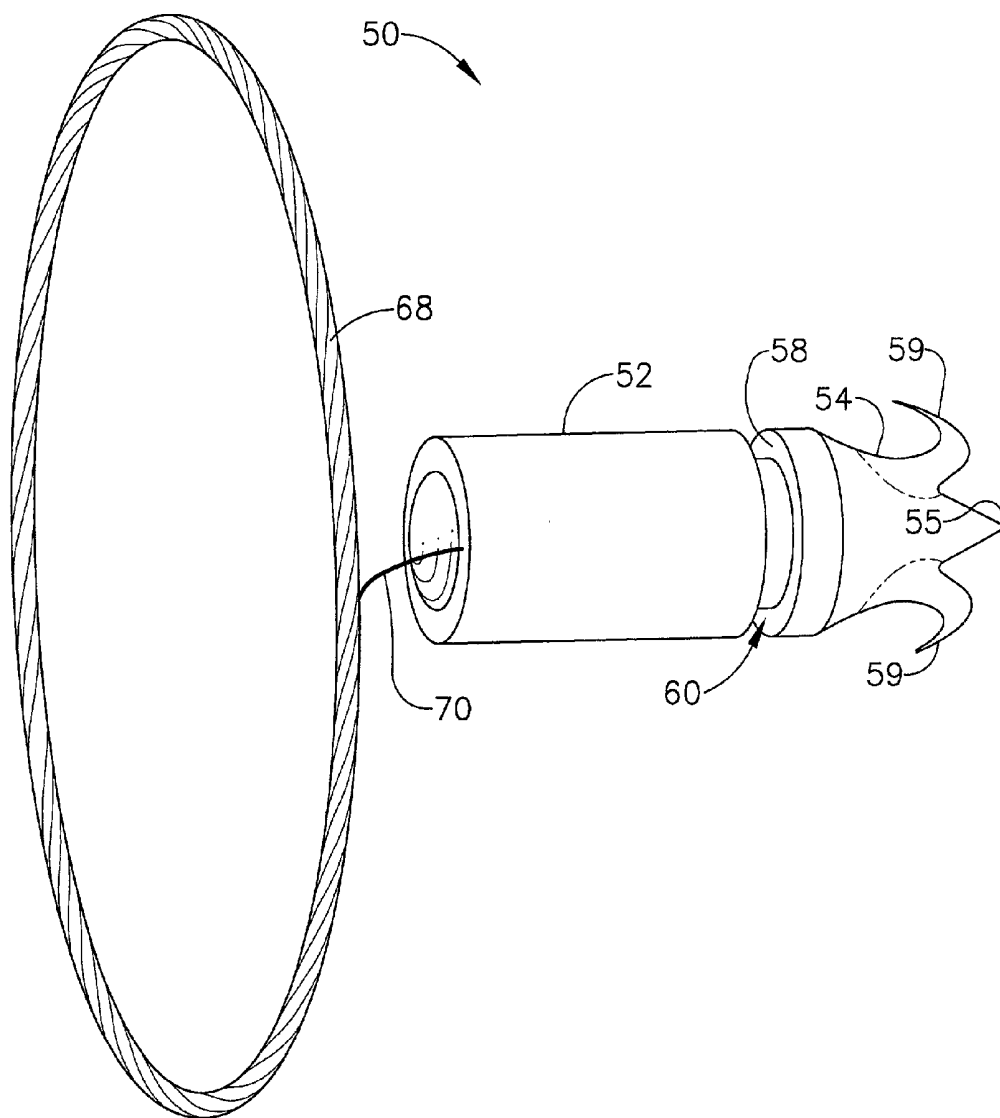

FIG. 4

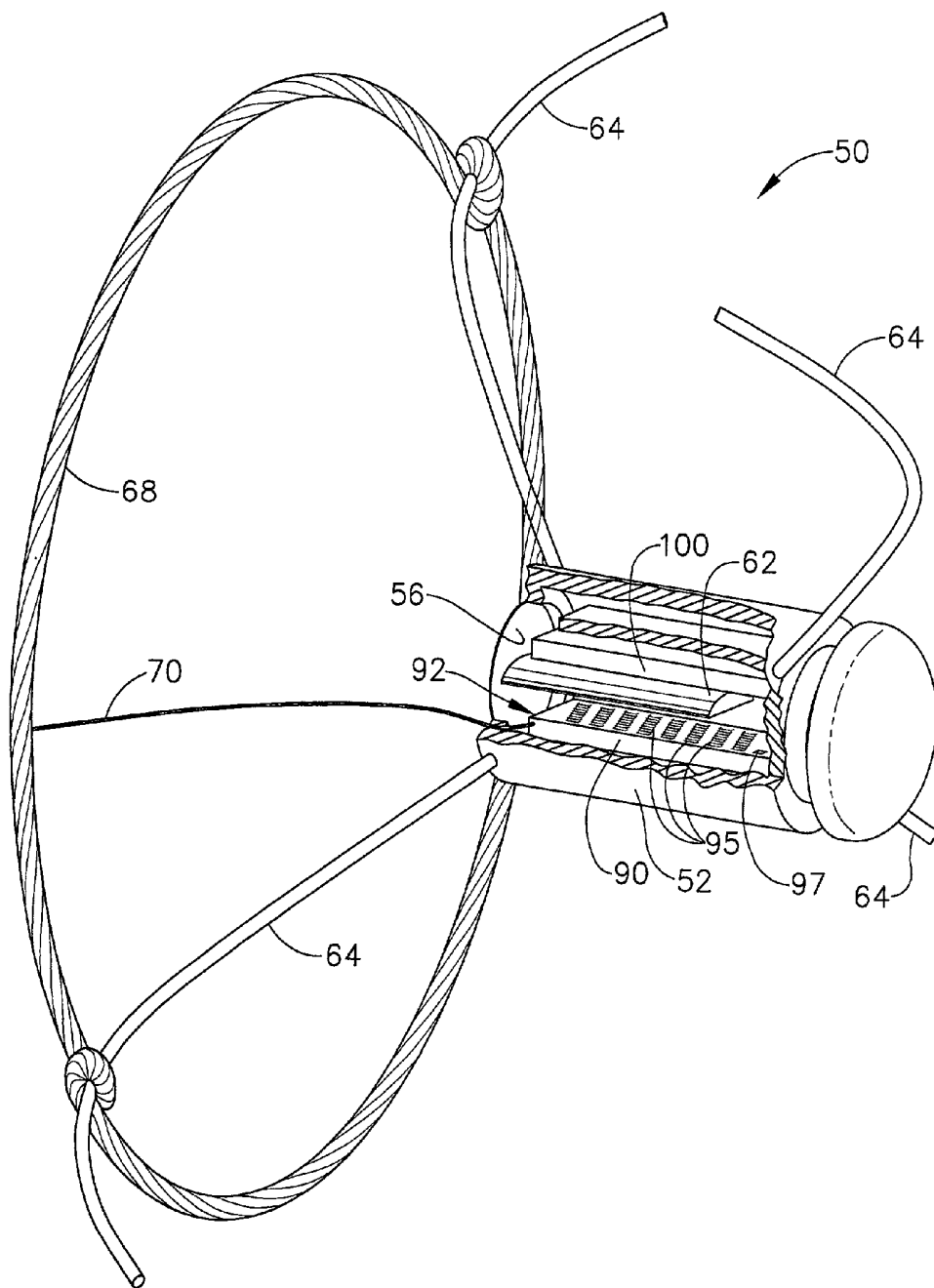

FIG. 5

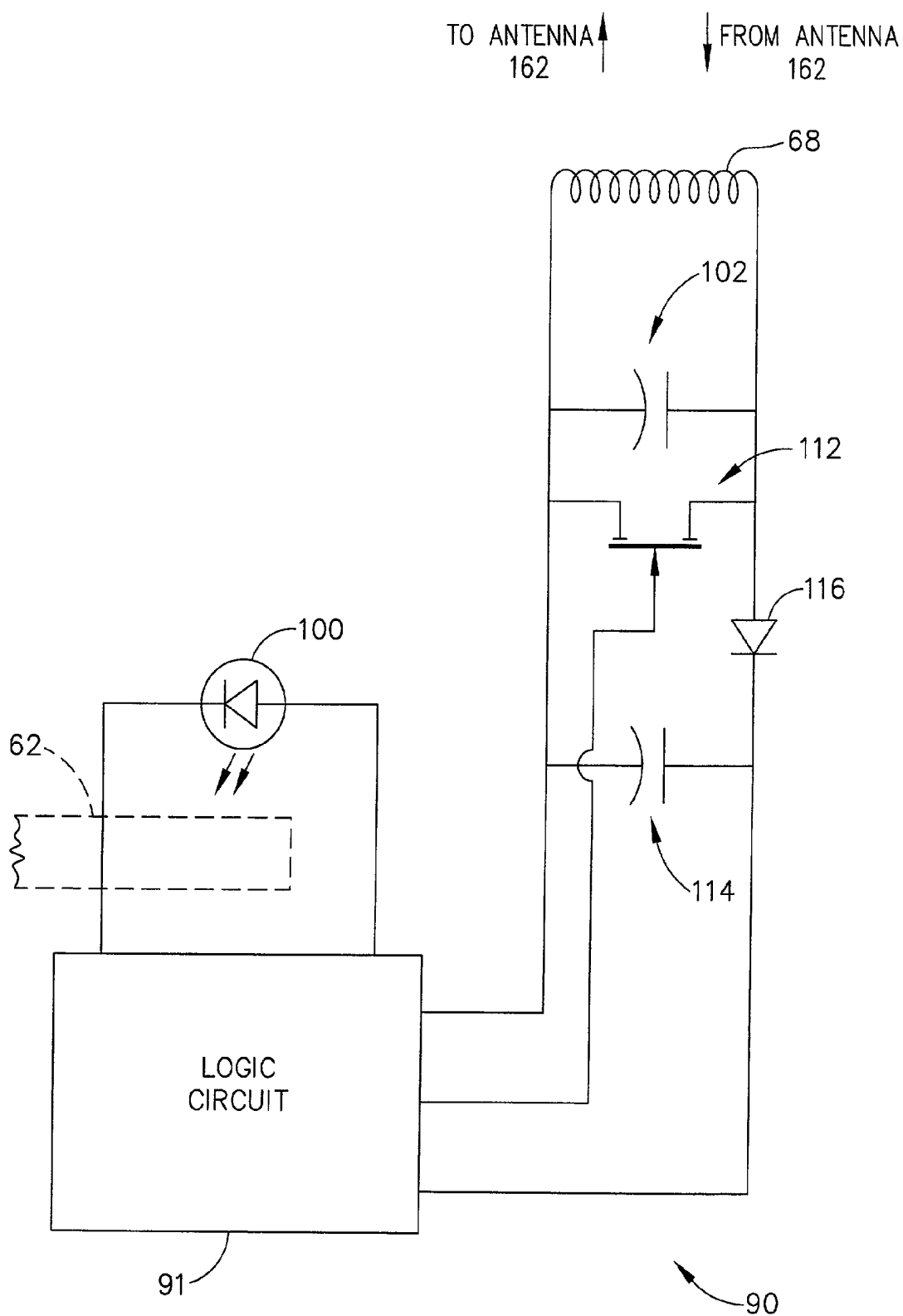

FIG. 6A

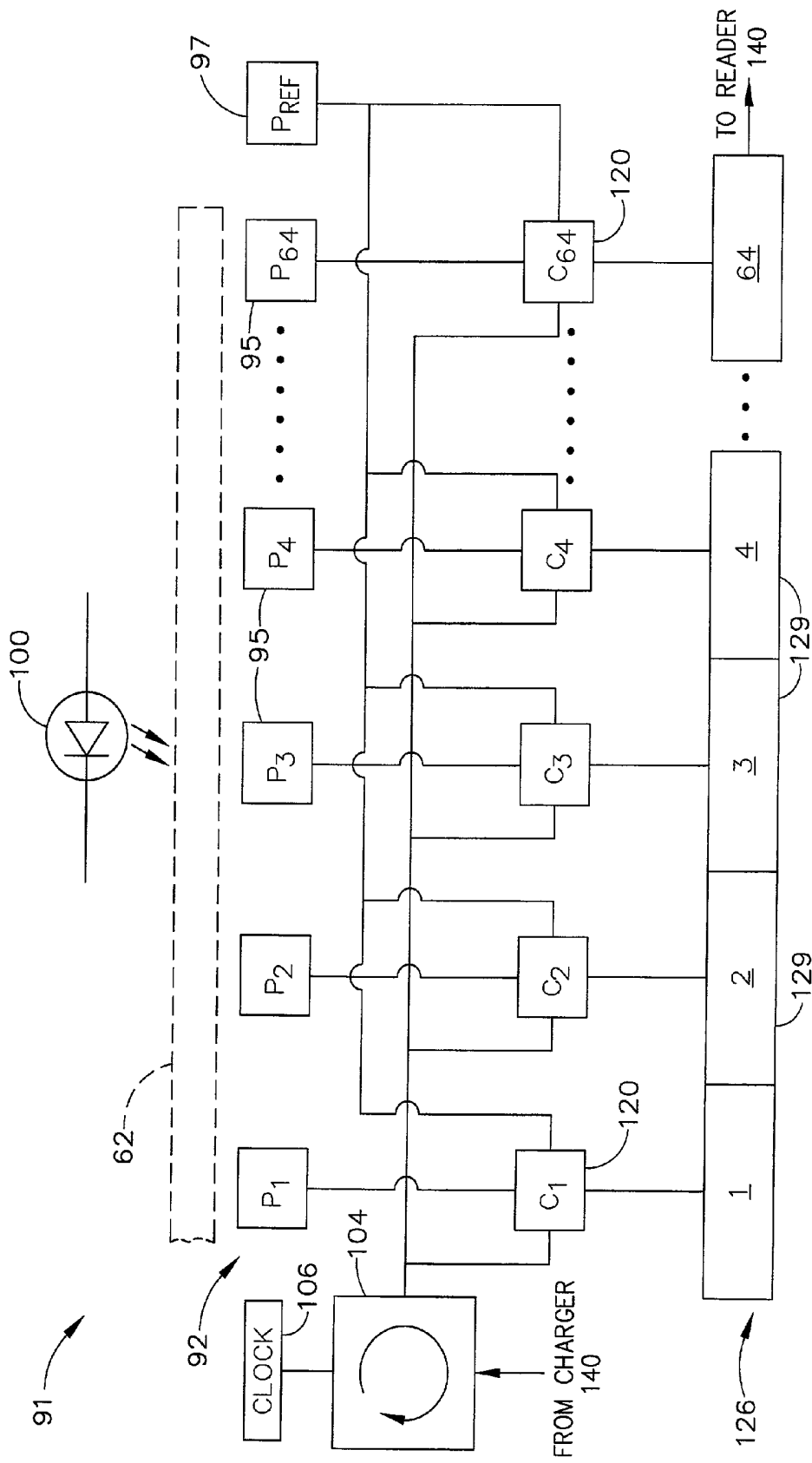

FIG. 6B

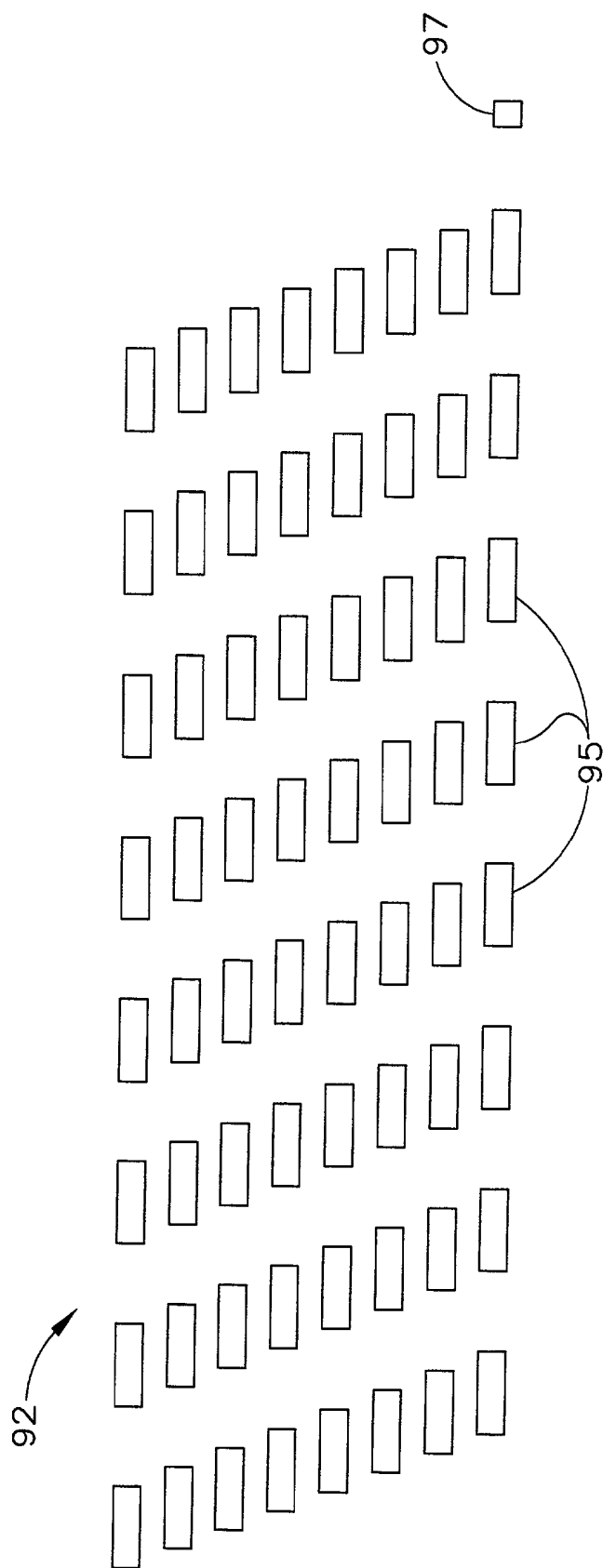
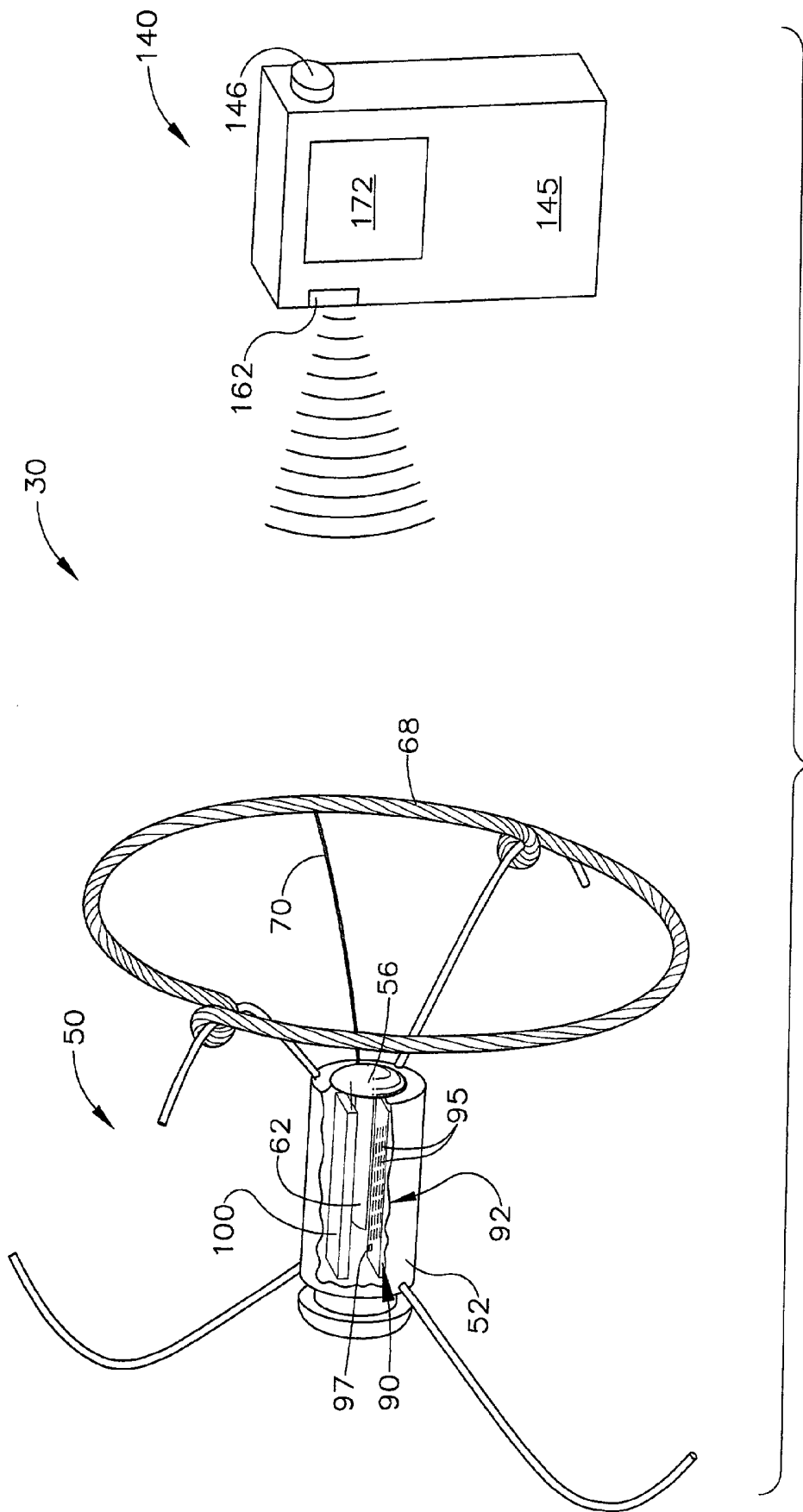

FIG. 7



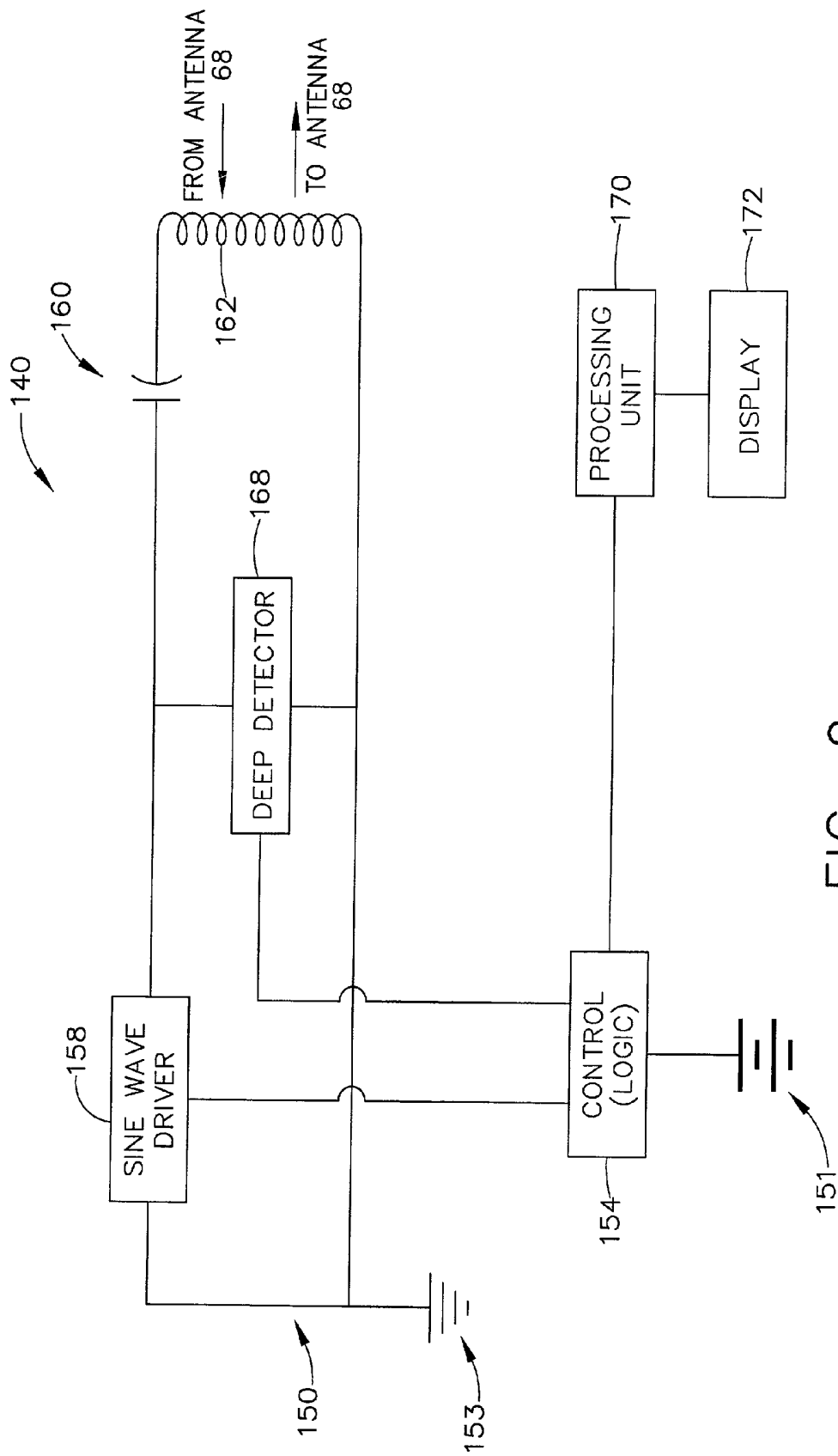

FIG. 9

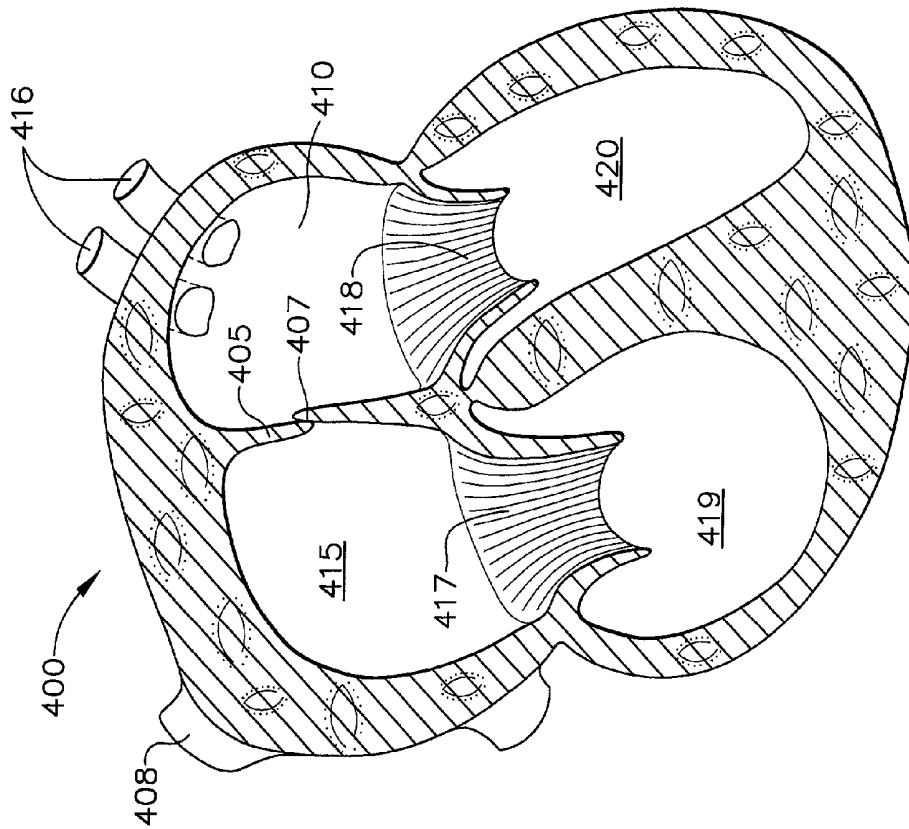

FIG. 10

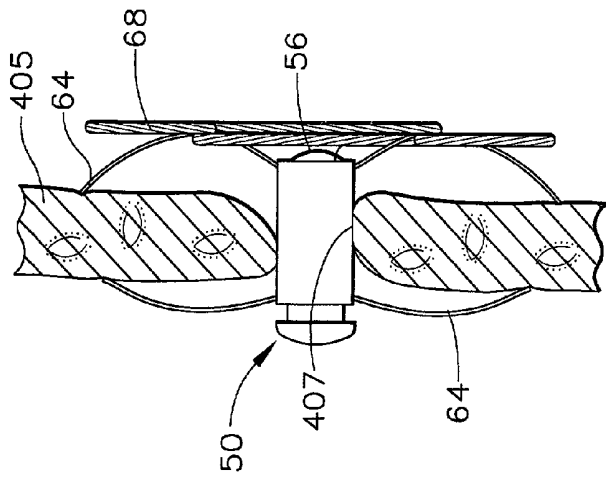

FIG. 11

TELEMETRIC READER/CHARGER DEVICE FOR MEDICAL SENSOR

FIELD OF THE INVENTION

[0001] The present invention relates, in general, to telemetric medical devices. More particularly, the present invention relates to a novel telemetric medical system which is capable of various medical applications including the measurement of a parameter within a patient's body, particularly an organ. One such application of the present invention is as an implantable telemetric endocardial pressure system, its associated novel components and their novel methods of use.

BACKGROUND OF THE INVENTION

[0002] In general, the use of implantable medical sensors in a patient is known. One example for an implantable sensor is disclosed in U.S. Pat. No. 4,815,469 (Cohen et al.) incorporated herein by reference. The disclosure is directed to an implantable medical sensor which determines the oxygen content of blood. The sensor includes a miniaturized hybrid circuit that includes light-emitting diode means, phototransistor means, and a substrate to which the light-emitting diode means and phototransistor means are bonded in a desired circuit configuration. The hybrid circuit is hermetically sealed within a cylindrical body made from a material that is substantially transparent to light, such as glass. Feedthrough terminals provide means for making an electrical connection with the hybrid circuit. The light-emitting diode means is driven with a stair-stepped current pulse. The purpose of the sensor is to sense the reflective properties of body fluid, such as blood, for spectrophotometric analysis. In one embodiment, the sensor is embedded within a bilumen pacemaker lead and positioned near the distal electrode of the lead so that the sensor resides within the heart when the lead is implanted within a patient, thereby allowing the sensed oxygen content of the blood within the heart to be a physiological parameter that can be used to control the pacing interval of a rate-responsive pacemaker.

[0003] U.S. Pat. No. 5,353,800 (Pahndorf et al.) discloses an implantable pressure sensor lead having a hollow needle adapted to be screwed into a patient's heart. The pressure sensor is supplied electrical power through conductors in the sensor.

[0004] There are cases where permanent positioning of the sensor is needed. One such case, for example, is disclosed in U.S. Pat. No. 5,404,877 (Nolan et al.), which is incorporated herein by reference. A leadless implantable cardiac arrhythmia alarm is disclosed which continuously assesses a patient's heart function to discriminate between normal and abnormal heart functioning and, upon detecting an abnormal condition, generates a patient-warning signal. The alarm is capable of sensing impedance measurements of heart, respiratory and patient motion and, from these measurements, generating an alarm signal when the measurements indicate the occurrence of a cardiac arrhythmia. It is important to note that the sensor uses an antenna system having a coil inductor for generating an electromagnetic field into tissue for detecting changes in impedance which relate to a physiological phenomena. For example, the size of the inductor is preselected in order to match the dimensions of the organ or structure to be measured.

[0005] There are also several known implantable devices that employ telemetry for transmitting or receiving data from an external device. One such device is, for example, the system disclosed in U.S. Pat. No. 6,021,352 (Christopherson et al.). The device utilizes a pressure sensor as a transducer for sensing respiratory effort of the patient. Respiratory waveform information is received by an implantable pulse generator (IPG)/simulator from a transducer and inspiration synchronous simulation is provided by the IPG.

[0006] One other telemetric implantable device is disclosed in U.S. Pat. No. 5,999,857 (Weijand et al.). This reference discloses a telemetry system for use with implantable devices such as cardiac pacemakers and the like, for two-way telemetry between the implanted device and an external programmer. The system employs oscillators with encoding circuits for synchronous transmission of data symbols in which the symbols form the telemetry carrier. The system provides circuits for higher density data encoding of sinusoidal symbols, including combinations of BPSK, FSK, and ASK encoding. Embodiments of transmitters for both the implanted device and the external programmer, as well as modulator and demodulator circuits, are also disclosed. It is important to note that the implant device has its own power supply in the form of a battery for powering all of the circuitry and components of the implanted device.

[0007] It is also important to note, that to date, there has not been any telemetric medical system that is both a highly efficient system due to its components and their ease of use while providing extremely accurate information regarding a measured parameter in a patient's body.

SUMMARY OF THE INVENTION

[0008] The present invention is directed to a novel telemetric medical system for use with various medical applications such as monitoring medical conditions or measuring parameters within a patient's body for different types of organs, including tissue, as well as their function.

[0009] The present invention is a telemetric medical system comprising a telemetric medical sensor for implantation in a patient's body for measuring a parameter therein. The sensor comprises a housing, and a membrane at one end of the housing, wherein the membrane is deformable in response to the parameter. A microprocessor, which is in the form of a microchip, is positioned within the housing and operatively communicates with the membrane for transmitting a signal indicative of the parameter.

[0010] A signal reading and charging device is locatable outside of a patient's body and communicates with the sensor. The signal reading and charging device comprises a casing and a circuit within the casing. The circuit comprises a logic control unit and a processing unit operatively connected to the logic control unit. The logic control unit, through a deep detector, receives the transmitted signal from the sensor. The logic control unit also sends a powering signal to the sensor through a sine wave driver for remotely powering the sensor. The powering signal is a sinusoidal wave signal approximately 4-6 MHz. The processing unit includes an algorithm for converting the transmitted signal received from the sensor into a measured parameter. Additionally, the signal reading and charging device includes a

power source operatively connected to the circuit and a power switch for activating and deactivating the device.

[0011] The signal reading and charging device also includes an antenna coil for sending the powering signal to the sensor and for receiving the transmitted digital signal from the sensor. The antenna coil has inductive coupling with the sensor. The signal reading and charging device also includes a display, which is an LCD screen, for displaying the measured parameter.

[0012] The microprocessor, which is in the form of a microchip, comprises an array of photoelectric cells which are arranged in staggered rows. The array also includes a reference photoelectric cell located at one end of the array. A light emitting diode (LED) transmits light at the photoelectric cells and the reference photoelectric cell.

[0013] The sensor further comprises a shutter connected to the membrane and moveable between the photoelectric cells and the LED in response to the deforming of the membrane. The sensor is arranged such that the reference photoelectric cell is not blocked by the shutter and remains exposed to the light emitted by the LED.

[0014] The microchip further comprises a plurality of comparators operatively connected to the photoelectric cells and a buffer operatively connected to the comparators for storing and transmitting the digital signal. The sensor further comprises an antenna, in the form of a coil, operatively connected to the microchip wherein the antenna is located at the exterior of the housing. Alternatively, the antenna is located within the housing of the sensor. Preferably, the antenna coil is made of wire comprising silver and platinum iridium. Additionally, the antenna has 20-25 turns.

[0015] The sensor according to the present invention further comprises a plurality of anchoring legs resiliently attached to the housing for anchoring the sensor into tissue. Additionally, the housing optionally includes a notch in an outer surface of the housing to facilitate deployment. The housing further optionally includes a circumferential groove at the notch to further facilitate deployment.

[0016] In another embodiment for the sensor, the housing further includes a tapered end and a piercing tip thereon. The tapered end further includes helical threads thereon for threading the sensor housing directly into tissue. An alternative embodiment includes a plurality of tissue barbs on the tapered end for anchoring the sensor housing directly into tissue.

[0017] The present invention also includes a method for telemetrically measuring a parameter in a patient's body comprising the steps of providing a telemetric medical sensor comprising a housing having a membrane at one end of the housing wherein the membrane is deformable in response to the parameter, and a microchip is positioned within the housing and operatively communicates with the membrane for transmitting a signal indicative of the parameter. The sensor is implanted at a site within the patient's body and the parameter is telemetrically measured from outside of the patient's body with a signal reading and charging device. The method also includes telemetrically powering the sensor from outside of the patient's body with the signal reading and charging device. The measured parameter is then displayed on the display of the signal reading and charging device.

[0018] The method according to the present invention also includes a method for telemetrically measuring a parameter in a patient's heart wherein the method comprises the steps of imaging the heart, through the use of transesophageal ultrasonic imaging, and identifying an implantation site in the heart. An opening is created in the tissue at the implantation site and a sensor comprising a housing, a membrane at one end of the housing wherein the membrane is deformable in response to the parameter, and a microchip positioned within the housing and operatively communicating with the membrane for transmitting a signal indicative of the parameter is provided. The sensor is placed within the opening and the parameter is telemetrically measured from outside of the patient's body based on the transmitted signal by the sensor.

[0019] The method also includes telemetrically powering the sensor from outside of the patient's body and displaying the measured parameter with a signal reading and charging device. Parameter measurements are made multiple times per second with the signal reading and charging device.

[0020] According to the present invention, the sensor is positioned within a chamber of the heart by using the septum as an implantation site, for instance, the fossa ovalis. Alternatively, the sensor is positionable at other anatomical sites within the heart and other organs and tissue.

[0021] One parameter that is measured with the system and method according to the present invention is hemodynamic blood pressure in a chamber of the heart. Accordingly, the method according to the present invention further includes taking between 10-20 parameter measurements per second.

[0022] Moreover, the method further includes creating the opening in the tissue with a needle. In one embodiment of the present invention, the sensor includes a plurality of anchoring legs on the sensor for anchoring the sensor to the tissue. Additionally, the sensor is coated with a nonthrombogenic agent in order to prevent thrombosis within the heart upon implantation of the sensor.

[0023] Another embodiment of the method according to the present invention includes a method for telemetrically measuring a parameter in a patient's heart wherein the method comprises the steps of imaging the heart with transesophageal ultrasonic imaging and identifying an implantation site in the heart. A sensor comprising a housing and a membrane at one end of the housing wherein the membrane is deformable in response to the parameter and a tapered distal end and piercing tip at the other end of the housing is provided. The sensor further comprises a microchip positioned within the housing and operatively communicating with the membrane for transmitting a signal indicative of the parameter. The sensor is implanted at the site with the piercing tip and the tapered distal end of the sensor. The parameter is telemetrically measured from outside of the patient's body based on the transmission signal by the sensor. Additionally, the sensor is telemetrically powered from outside of the patient's body. A signal reading and charging device is used outside of the patient's body to measure the parameter, power the sensor, and display the measured parameter. Accordingly, parameter measurements are made multiple times per second with the signal reading and charging device.

[0024] The sensor is positioned within a chamber of the heart and the implantation site is the septum, for instance, at

the fossa ovalis. With the system and method according to the present invention, one parameter that is measured is hemodynamic blood pressure within a chamber of the heart. For instance, 10-20 parameter measurements are made per second for monitoring blood pressure in accordance with the present invention.

[0025] Alternatively, the sensor includes helical threads on the tapered distal end of the sensor and the sensor is anchored into the tissue at the site by threading the tapered distal end of sensor directly into the tissue. Alternatively, the sensor includes a plurality of tissue barbs on the tapered distal end of the sensor and the sensor is anchored into the tissue at the site with the tissue barbs.

[0026] The present invention will be more fully understood from the following detailed description of the preferred embodiments thereof, taken together with the drawings, in which:

BRIEF DESCRIPTION OF THE DRAWINGS

[0027] FIG. 1 is a schematic illustration of a telemetric implantable medical sensor according to the present invention;

[0028] FIG. 1 is a top view of the sensor of FIG. 1;

[0029] FIG. 3 is a schematic illustration of an alternative embodiment of the sensor of FIG. 1 having a tapered distal end with helical threads and tissue piercing tip for anchoring into tissue;

[0030] FIG. 4 is another alternative embodiment of the sensor of FIG. 1 having a tapered distal end with tissue piercing tip and a plurality of tissue piercing barbs thereon;

[0031] FIG. 5 is a partial perspective view of the sensor of FIG. 1 with some parts removed in order to reveal the internal components of the sensor;

[0032] FIG. 6A is schematic diagram illustrating a microprocessor circuit for the sensor according to the present invention;

[0033] FIG. 6B is a schematic diagram illustrating a logic circuit for the microprocessor circuit of FIG. 6A;

[0034] FIG. 7 is a schematic illustration depicting an array of photoelectric cells for the sensor according to the present invention;

[0035] FIG. 8 is a schematic illustration depicting the telemetric system according to the present invention including the sensor of FIG. 1 and a signal reading and charging device remotely located from and in communication with the sensor;

[0036] FIG. 9 is a schematic diagram illustrating a read/charge circuit for the signal reading and charging device of FIG. 8;

[0037] FIG. 10 is a schematic illustration of a patient's heart; and

[0038] FIG. 11 is a schematic illustration depicting the sensor fully deployed within a tissue aperture according to the present invention.

DESCRIPTION OF THE PREFERRED EMBODIMENTS

[0039] The present invention relates to a novel telemetric medical system 30, as schematically illustrated in FIG. 8, as

well as its novel components and methods of use useful for various medical applications, as explained and demonstrated herein.

[0040] One aspect of the system 30 of the present invention is to remotely sense and measure a characteristic or parameter (or number of various parameters including the magnitude of any parameter) within a patient's body, or within an organ or tissue of the patient's body, through the use of a novel implantable telemetric medical sensor 50, which is completely wireless, and a novel signal reading and charging device 140 which operatively communicates with the sensor 50.

Telemetric Sensor

[0041] As schematically illustrated in FIG. 1, the sensor 50 comprises a housing 52 made of a biocompatible material such as polysilicon or titanium. The housing 52 preferably has a cylindrical shape although any type of shape for the housing 52 is acceptable. The housing 52 has an approximate length ranging between 4-5 mm and an approximate diameter ranging from 2.5-3 mm in diameter. The housing 52 can also be smaller, e.g. 3 mm in length and a 1-2 mm outer diameter. The housing 52 includes cylindrical walls that are approximately 250 μm in thickness. A flexible membrane 56 made of a deformable material is fixed to one end of the housing 52. A notch 58 and a circumferential groove 60 are provided on an exterior surface of the housing 52 for facilitating delivery and implantation of the sensor 50.

[0042] The membrane 56 is made of a flexible or deformable material such as polysilicon rubber or polyurethane. The membrane 56 has an approximate thickness of 20 μm and has a diameter ranging from approximately 1.5-2 mm. The membrane 56 is normally biased outwardly from the housing 52 due to the interior pressure within the housing 52. The membrane 56 is forced to bulge inwardly into the housing 52 whenever the pressure exterior of the housing 52 exceeds the internal pressure within the housing 52.

[0043] Since the membrane 56 is deformable and normally biased outwardly from the housing 52, the membrane 56 responds directly to the environment of the tissue or organ being monitored and/or measured for a particular characteristic or parameter. In response to even the slightest changes in these characteristics or parameters, the membrane 56 deforms inwardly toward the interior of the housing 52. Accordingly, there is a direct relationship or correspondence between any change in measured characteristic or parameter and the amount or degree of deforming action or movement of the membrane 56.

[0044] It is important to note that the membrane 56 has a relatively large area in dimension when compared to solid state membrane devices, such as piezoelectric sensors or fabricated memory chips utilizing membranes. Accordingly, the requirements from the electronics of the sensor 50 are less demanding. Additionally, the membrane 56 has a much larger deflection than that of the solid state membrane.

[0045] The sensor 50 also includes an antenna coil 68 which is operatively connected to the internal components of the sensor 50 by an antenna lead 70. The antenna coil 68 is an inductance coil having a spiralled coil configuration. The material used for the antenna wire is approximately 90% silver content with a cladding of platinum iridium of

approximately 10% content. The antenna coil **68** is preferably made of 20-25 turns of 30 μm thickness wire. The antenna outer diameter is 1.5-2.0 cm (**FIG. 2**).

[0046] Accordingly, due to these features, the antenna coil **68** possesses a very low parasitic capacitance. Additionally, the antenna coil **68**, due to its silver/platinum content wire has extremely high conductivity and is extremely flexible.

[0047] Although antenna **68** is described as being external of the housing **52**, it is well within the scope of the invention to include any type of suitable antenna, such as an antenna that is contained within the housing **52**.

[0048] The sensor **50** further includes anchoring legs **64** resiliently biased to the exterior of the housing **52**. The number of anchoring legs **64** can vary depending on the desired degree of anchoring and geography of the anatomy in which the sensor **50** is to be placed. The anchoring legs **64** are made from wire utilizing shape memory metal material, such as a nickel titanium alloy (NiTiNol). The anchoring legs **64** have a concave configuration with a radius of curvature that curves into the tissue or organ in which the sensor **50** is to be anchored. Other appropriate configurations for the anchoring legs **64** are also contemplated herein.

[0049] If desirable, the sensor **50** is coated with a non-thrombogenic or anticoagulating agent such as Heparin prior to implantation in order to prevent thrombosis, clotting, etc.

[0050] **FIG. 3** illustrates an alternative embodiment of the sensor **50** having a tapered end **54** on the housing **52**. The tapered end **54** has a tissue piercing tip **55** and helical threads **57** arranged on an outer surface of the tapered end **54** in order to facilitate the direct anchoring of the tapered end **54** of the housing **52** through direct threading into tissue.

[0051] **FIG. 4** illustrates another alternative embodiment sensor **50** including a plurality tissue barbs **59** fixed to the tapered end **54** of the housing **52**. The barbs **59** have a tissue piercing tip curved outwardly away from the tissue piercing tip **55**. Accordingly, along with the tissue piercing tip **55**, the tissue barbs **59** grasp firmly into the tissue for firmly anchoring the housing **52** in the tissue.

[0052] As shown in **FIG. 5**, the interior of the housing **52** includes a microprocessor **90**, in the form of a microchip, fixed within one of the interior walls of the housing **52**. The lead **70** of the antenna coil **68** is operatively connected to the microprocessor **90**. Microprocessor **90** includes an array **92** of photoelectric cells **95** arranged in a patterned configuration, e.g. eight staggered rows containing eight photoelectric cells **95** in each row. A reference photoelectric cell **97** is located at one end of the array **92** resulting in an array **92** having a total of sixty-five photoelectric cells such as illustrated in **FIG. 7**. The photoelectric cell array **92** provides for 64 degrees of resolution. The pitch distance between each photocell **95** is approximately $\frac{1}{4}$ the size of a photocell **95**. Additionally, the reference photocell **97** has a dimension that is approximately the size of the pitch, e.g. $\frac{1}{4}$ the size of a photocell **95**, thus providing a resolution that is equal to a motion of $\frac{1}{4}$ of the photocell.

[0053] A light emitting diode (LED) **100** is operatively connected to the microprocessor **90** and is positioned above and spaced parallel and away from the photoelectric cell array **92**. A shutter **62** is connected to the inner surface of the

membrane **56** and extends longitudinally from the membrane **56** within housing **52**. The shutter **62** has a substantially D-shaped configuration and longitudinally extends between the LED **100** and the photoelectric cell array **92**. The shutter **62** is made from an aluminum alloy and is positioned such that the planar surface of the shutter **62** directly faces the photoelectric cell array **92**. The shutter **62** is fixed to the deformable membrane **56** such that the shutter **62** moves in association with the membrane **56**. Accordingly, when the membrane **56** is deflected inwardly into the housing **52** (due to the monitored or measured tissue or organ parameter), the shutter **62** longitudinally extends over a number of photoelectric cells **95** in the array **92** in direct relation to the inward movement of the membrane **56** as it is being deformed. Likewise, when the membrane **56** is deflected outwardly from the housing **52**, the shutter **62** moves longitudinally outwardly from the end of the housing **52** along with the membrane **56**. Accordingly, the shutter **62** obscures or blocks a number of the photoelectric cells **95** in accordance with the degree of movement of the membrane **56**. Thus, when the shutter **62** is positioned over a specific number of photoelectric cells **95**, light from the LED **100** is prevented from reaching the photoelectric cells **95** and affects signal transmission from these cells **95**. This arrangement constitutes an analog-to-digital (A/D) conversion which is power effective since there is a simple counting of the number of photocells that are on or off as a measure of the shutter's motion. Hence, the analog-to-digital conversion. Accordingly, the microprocessor **90** operatively communicates with the membrane **56**.

[0054] The reference photoelectric cell **97** is never obscured or covered by the shutter **62** since it is located at the far end (end away from the membrane **56**) of the array **92**. The shutter **62** and membrane **56** are calibrated such that even upon maximum deflection inwardly into the housing **52**, it results in the reference photoelectric cell **97** being permanently exposed to the LED **100** for use as a reference signal for the sensor **50**. Yet, the power dissipation of the photocell is very low.

[0055] As best shown in **FIG. 6A**, the microprocessor **90** is a circuit wherein the antenna coil **68** and a resonance capacitor **102** operate as a resonating oscillator for the sensor **50**. The antenna coil **68** receives transmitted RF signals sent by the signal reading and charging device **140** as illustrated in **FIGS. 8 and 9**. The RF signal received at the antenna coil **68** is a charging signal for powering the microprocessor **90**. Upon receiving the RF charging signal, the antenna coil **68** and capacitor **102** resonate and charge a charge capacitor **114** through diode **116**. Upon reaching a predetermined voltage threshold of approximately 1.2 V, the capacitor **114** powers the LED **100** and a logic circuit **91** through control unit **104**. Upon powering of the LED **100** by the charged capacitor **114**, the LED emits light to the photoelectric cell array **92** which is kept at negative voltage.

[0056] As illustrated in **FIG. 6B**, the photoelectric cell array **92** is designated P_1, P_2, \dots, P_{64} and P_{ref} respectively. Each photoelectric cell **95** (P_1 - P_{64}) are connected in parallel to a plurality of comparators **120** designated $C1, C2, \dots, C64$. The reference photoelectric cell **97** is operatively connected to each comparator **120** ($C1$ - $C64$) for providing a reference signal to each comparator **120** in comparison to the signal received from each respective photoelectric cell **95**. The

logic circuit **91** is powered and controlled by the control unit **104** and a clock **106**. The control unit **104** is connected to each comparator **120**.

[0057] A buffer **126** having a plurality of buffer cells **129** (sixty-four total buffer cells corresponding to each comparator C1-C64) is operatively connected to the comparators **120**. Each buffer cell **129** is a flip-flop, or memory cell, which receives a signal from its respective comparator C1-C64 resulting in a binary number which is sixty-four digits long (a series of ones or zeros). All buffer cells **129** are filled in a single clock cycle and each buffer **129** has either "0" or "1" in it. After all sixty-four buffer cells **129** have been filled with its respective binary number, the digital signal representing all sixty-four bytes is sent to the signal reading and charging device **140** by the control unit **104**. After transmitting the digital signal, the control unit **104** is reset by the clock **106** awaiting further signal inputs from the signal reading and charging device **140**. Encryption of the binary number is provided by the signal reading and charging device **140** described in greater detail below.

[0058] Upon filling the sixty-fourth buffer cell, the digital signal is transmitted from the buffer **126** and activates switch **112** resulting in a transmission of the digital signal from the antenna coil **68** to the antenna coil **162** of the signal reading and charging device **140**.

[0059] One main aspect of the system **30** of the present invention is that the sensor **50** is both a wireless transponder and a low-powered device capable of fast update rate, despite its passive nature, due to the inherent analog-to-digital (A/D) conversion mechanism employed in the sensor **50**, e.g. the photoelectric cell array **92**, which directly converts the membrane **56** deflection into a digital signal, with no power consumption as would be required for a conventional electronic A/D converter.

Signal Reading and Charging Device

[0060] As illustrated in FIG. 8, the signal reading and charging device **140** according to the present invention is for use outside of a patient's body or at the exterior surface of the patient's body. The signal reading and charging device **140** includes a casing **145**, which is a housing, having a liquid crystal display (LCD) display screen **172** mounted in an opening in the housing **145**. The signal reading and charging device, also commonly referred to as a read/charge device, reader/charger or reader/charger device, is activated by a power switch or toggle **146** extending from the casing **145**. Antenna coil **162** operatively communicates with the antenna coil **68** of the sensor **50** by inductance coupling.

[0061] As shown in FIG. 9, once the logic circuit **91** transmits the digital signal from the sensor **50** through sensor antenna coil **68**, the coupling constant of the reader/charger antenna coil **162** is changed and is detected by a deep detector **168** operatively connected to the reader/charger antenna coil **162**. The deep detector **168** is sensitized to detect a change in the amplitude of the signal for as low as a 0.01% change in amplitude.

[0062] A read/charge logic control unit **154** is operatively connected to the deep detector **168** for determining the threshold for the deep detector **168**. The logic control unit **154** also includes a power source **151** for powering the components of the reader/charger device **140**.

[0063] The reader/charger circuit **150** further includes a processing unit **170** operatively connected to the logic control unit **154**. The processing unit **170** contains the algorithm for converting the digital signal received from the sensor **50** (FIG. 8) into a measured parameter for the medical parameter, condition or characteristic sensed at the implanted sensor **50**. Additionally, the processing unit **170** includes encryption code for encryption of the digital signal (sixty-four bit signal) using encryption algorithms such as exclusive-OR (XOR), RSA methods (RSA Security, Inc.), etc.

[0064] For example, where the parameter being measured is hemodynamic blood pressure, within an organ such as the chamber of a heart, once the processing unit **170** receives the digital signal, the processing unit **170**, through its algorithm, converts the digital signal (binary number) to a pressure value, using a look-up comparison table, or analytical expression representing the relation between the shutter **62** deflection in the sensor **50** versus the exterior sensor pressure at the membrane **56**, which is given below:

$$P=(KD^3/A^2)X^2$$

[0065] where P is the pressure value, D is the thickness of the membrane, A is the membrane radius, X is the deflection from the equilibrium and K is a constant.

[0066] The LCD display **172** is operatively connected to the processing unit **170** for displaying the measured parameter (hemodynamic blood pressure in the example above) converted from the digital signal in real time.

[0067] By utilizing the signal reading and charging device **140** at the exterior of the patient's body, continuous parameter readings (for determining aspects of the parameter such as magnitude) are obtainable for both the mean and active or individual values of the sampled parameter.

[0068] When measuring characteristics of a body fluid such as blood, the signal reading and charging device **140** maintains an active reading volume around the sensor **50**, ranging anywhere from 5-25 cm, and preferably, an active reading volume ranging approximately 10-15 cm. Moreover, with the telemetric medical system **30**, through the sensor **50**, and the signal reading and charging device **140**, it is possible to sample multiple readings per second. Preferably, approximately 10-20 readings per second are possible with the present invention.

[0069] Other attributes associated with the present invention when utilized as a pressure monitor in a chamber of the heart include monitoring a pressure range of +/-30 mmHg; an accuracy (at 5 mSec. integration) of +/-1 mmHg with a repeatability (at 5 mSec. integration) of +/-1 mmHg. It is important to note that the pressure boundaries can be changed easily by changing the size and dimensions, such as width, of the membrane without any change to the electronics. This is important for allowing the present invention to be adapted for various applications while using the same design.

[0070] The control unit **154** is also operatively connected to a sine-wave driver **158** for generating a sinusoidal wave signal of approximately 4 to 6 MHz. The sinusoidal wave signal is generated by the sine-wave driver **158** through capacitor **160** to the reader/charger antenna coil **162** for transmission or sending to the antenna coil **68** of the sensor **50** in order to power or charge the sensor **50** as described above.

Medical Procedures

[0071] As mentioned above, the telemetric medical system 30 according to the present invention is useful for nearly any type of medical diagnostic procedure where it is desirable to implant the sensor 50 at a portion of the body, particularly tissue or organ of interest. The telemetric medical system 30 according to the present invention allows for remote monitoring and diagnosis of a condition of the tissue or organ by being able to rapidly sample various parameters or variables of any physical condition within the patient's body at the site of interest. Since the telemetric medical system 30 is wireless, these types of procedures are conducted in a completely non-invasive manner with minimal trauma to the patient.

[0072] One particular example for the telemetric medical system 30 according to the present invention, its components and their method of use, is in the field of congestive heart failure (CHF). CHF is defined as a condition in which a heart 400 (FIG. 10) fails to pump enough blood to the body's other organs. This can result from narrowed arteries that supply blood to the heart muscle (due to coronary artery disease), past heart attack, or myocardial infarction, with scar tissue that interferes with the heart muscle's normal work, high blood pressure, heart valve disease due to past rheumatic fever (in valves such as semilunar valve, tricuspid valve 417 or mitral valve 418) or other causes, primary disease of the heart muscle itself, called cardiomyopathy, defects in the heart present at birth such as congenital heart disease, infection of the heart valves and/or heart muscle itself (endocarditis and/or myocarditis).

[0073] The ailing heart 400 keeps functioning but not as efficiently as it should. People with CHF cannot exert themselves because they become short of breath and tired. As blood flowing out of the heart 400 slows, blood returning to the heart 400 through the veins backs up, causing congestion in the tissues. Often swelling (edema) results, most commonly in the legs and ankles, but possibly in other parts of the body as well. Sometimes fluid collects in the lungs and interferes with breathing, causing shortness of breath, especially when a person is lying down. Heart failure also affects the ability of the kidneys to dispose of sodium and water. The retained water increases the edema.

[0074] CHF is the most common heart disease in the United States and it is estimated that over 5 million patients suffer from it. One of the more predictive hemodynamic parameters being measured in patients with CHF is blood pressure in the left atrium 410, e.g. left atrial (LA) pressure. To date, this parameter is measured by employing invasive right heart catheterization with a special balloon catheter such as the Swan-Gantz catheter.

[0075] Accordingly, in moderating for effects of CHF, it is desirable to measure the blood pressure in a particular chamber (either right atrium 415, right ventricle 419, left atrium 410 or left ventricle 420) in the heart 400 utilizing the telemetric medical system 30 according to the present invention.

[0076] Accordingly, in conducting one preferred method according the present invention, blood pressure can be directly monitored in the left atrium 410 of the heart 400. Accordingly, it is desirable to implant the sensor 50 at fossa ovalis 407 within the septum 405.

[0077] With respect to the specific anatomy of the septum 405, in approximately 15% of the normal population, the fossa ovalis 407 has a pre-existing hole or opening that either remains open or patent and is normally covered by a

small flap of tissue. In approximately 85% of the normal population, the fossa ovalis 407 is completely occluded, e.g. there is no hole in the septum 405.

[0078] (1) Transcatheter Approach

[0079] In accordance with the method according to the present invention, a transcatheter approach has been found to be particularly useful for the patient population already having the pre-existing hole at the fossa ovalis 407. Accordingly, in performing this method according to the present invention, first, a transesophageal ultrasonic probe (not shown) is inserted into the patient's mouth and placed in the esophagus. In most cases, the transesophageal ultrasonic probe is positioned approximately 30-35 cm from the mouth, i.e. in most cases positioned just above the patient's stomach.

[0080] Under transesophageal ultrasonic guidance, a wire (not shown) is inserted into the right atrium 415 through an appropriate vessel such as the inferior vena cava 408 wherein the wire is guided through the fossa ovalis 407 by gently lifting the tissue flap away from the patent opening at the fossa ovalis 407. Once the wire is inserted through the fossa ovalis 407, the wire is guided to one of the pulmonary veins 416 for placement of the distal end of the wire in order to properly position and anchor the wire in the opening of the pulmonary vein 416. Accordingly, the pulmonary vein 416 has been proven to be a very reliable and steady anchoring point for the wire.

[0081] Once the wire is properly positioned in the fossa ovalis 407 and anchored in the pulmonary vein 416, a catheter sheath ("over-the-wire" type —not shown) is guided over the wire through the right atrium 415 and the fossa ovalis 407 and positioned within the left atrium 410, for instance, very close to the opening of the pulmonary vein 416.

[0082] Once the catheter sheath has been properly positioned, the wire is removed from the patient's heart 400 and the sensor 50 is delivered through the catheter sheath by one of the many standard catheter-based delivery devices (not shown). Accordingly, the sensor 50 can be delivered to the fossa ovalis 407 by any of the typical catheter-based delivery devices normally associated with implantable pacemakers, electrodes, atrial septal defect (ASD) occlusion devices, etc. Accordingly, the sensor 50 is deliverable with typical delivery devices such as the Amplatzer® Delivery System, manufactured by AGA Medical Corporation of Golden Valley, Minn..

[0083] After placement of the catheter sheath, the sensor 50 is deployed from the catheter sheath within the fossa ovalis 407 as best illustrated in FIG. 11. Upon deployment, the sensor 50 utilizes the anchoring legs 64 for anchoring the sensor 50 to the septum 405 and occluding the opening at the fossa ovalis 407.

[0084] (2) Anterograde Approach

[0085] The sensor 50 is placed in the fossa ovalis 407 for those patients not having a pre-existing opening in the fossa ovalis 407 through means of an anterograde approach. Once again, a transesophageal ultrasonic probe is positioned in the patient's esophagus as described above. Under transesophageal ultrasonic imaging guidance, an opening is made in the septum 405 at the fossa ovalis 407 in order to place and accommodate the sensor 50. Thus, the opening is made with a standard needle catheter (not shown) such as the BRK™ Series Transseptal Needle manufactured by St. Jude Medi-

cal, Inc. of St. Paul, Minn.. Accordingly, under transesophageal ultrasonic guidance, the needle catheter is initially placed in the right atrium **415** and positioned at the fossa ovalis **407**. At this point, the tip of the needle of the needle catheter penetrates the fossa ovalis **407** and the catheter is inserted through the fossa ovalis **407** into the left atrium **410** through the newly created opening in the fossa ovalis **407** by the needle catheter. Once the opening in the fossa ovalis **407** is created, the sensor **50** is introduced with the delivery device, such as the delivery device described above, and placed in the fossa ovalis opening as shown in **FIG. 11**. Upon deployment of the anchoring legs **64**, the opening in the fossa ovalis **407** is occluded around the sensor housing **52** and the sensor **50** fixed to the septum **405** in a secure fashion.

[0086] It is important to note that transesophageal ultrasonic imaging is utilized for both the transcatheter and the antegrade approach as described above in accordance with each method step of the present invention. Since either method according to the present invention can be utilized with the transesophageal ultrasonic guidance, other imaging modalities such as fluoroscopy can be eliminated. As such, the methods according to the present invention can be conducted in an outpatient clinic or doctor's office as a bedside procedure. By eliminating the need for a fluoroscope, the method according to the present invention also eliminates the need for conducting the procedure in a catheter lab which only adds additional time and cost to the procedure and additional time and inconvenience to the patient.

[0087] After the sensor **50** has been implanted in the patient's septum **405**, the patient is provided with standard treatment to prevent excessive coagulation or endothelialization. For instance, it is common practice to prescribe aspirin and/or an anticoagulant such as Heparin for a period of time such as six months.

[0088] With either of the methods described above, the sensor **50** is fixed to the septum **405** in order to provide real time pressure monitoring in the left atrium **410**. Since the sensor **50** is a wireless transponder and a battery low power receiver, the sensor **50** does not impede the natural function of the heart **400** and is truly minimally invasive.

[0089] By utilizing the signal reading and charging device **140** at the exterior of the patient's body, continuous pressure readings are obtainable for both the mean and pulsating values of pressure in the left atrium **410** provided by the sensor **50**.

[0090] With the telemetric system **30**, the signal reading and charging device **140** maintains an active reading volume around the sensor **50** ranging anywhere from 5-25 cm, and preferably, an active reading volume ranging approximately 10-15 cm. Moreover, with the sensor **50**, and the signal reading and charging device **140**, it is possible to sample multiple readings per second. Preferably, approximately 10-20 readings per second are possible with the present invention.

[0091] Other attributes associated with the present invention when utilized as a pressure monitor in a chamber of the heart include monitoring a pressure range of plus/minus 30 mmHg; and accuracy (at five Mmsec. integration) of plus/minus 1 mmHg and a repeatability (at 5 msec. integration) of plus/minus 1 mmHg.

[0092] Although preferred embodiments are described hereinabove with reference to a medical system, devices,

components and methods of use, it will be understood that the principles of the present invention may be used in other types of objects as well. The preferred embodiments are cited by way of example, and the full scope of the invention is limited only by the claims.

What is claimed is:

1. A signal reading and charging device for use with an implantable telemetric medical sensor, the device comprising:

a casing; and

a circuit within the casing comprising a logic control unit and a processing unit, the logic control unit for sending a powering signal to the telemetric medical sensor for remotely powering the sensor, the logic control unit also for receiving a transmitted signal from the sensor, the processing unit operatively connected to the control unit for converting the transmitted signal by the sensor into a measured parameter.

2. The device of claim 1, including an antenna coil for sending the powering signal and receiving the transmitted signal from the sensor.

3. The device of claim 2, including a display for displaying the measured parameter.

4. The device of claim 3, including a sine wave driver operatively connected to the control unit for sending the powering signal to the sensor.

5. The device of claim 4, wherein the powering signal is a sinusoidal wave signal approximately 4-6 MHz.

6. The device of claim 3, wherein the display is an LCD screen.

7. The device of claim 1, wherein the processing unit decodes the transmitted signal.

8. The device of claim 7, including a deep detector for receiving the transmitted signal.

9. The device of claim 8, including a power source operatively connected to the circuit.

10. The device of claim 9, including a power switch for activating and deactivating the device.

11. The device of claim 7, wherein the processing unit includes an algorithm for converting the transmitted signal into a measured parameter.

12. The device of claim 11, including an LCD for displaying the measured parameter.

13. The device of claim 12, wherein the parameter is hemodynamic blood pressure.

14. The device of claim 8, wherein the deep detector detects a change in amplitude for the transmitted signal for as low as 0.01% change in amplitude.

15. The device according to claim 2, wherein the antenna coil has inductive coupling with the sensor.

16. The device of claim 2, wherein the circuit has an active reading volume around the sensor of approximately 5-25 cm.

17. The device of claim 16, wherein the active reading volume is approximately 10-15 cm.

18. The device of claim 2, wherein the circuit maintains multiple readings per second from the sensor.

19. The device according to claim 18, wherein there are 10-20 readings per second.

专利名称(译)	用于医疗传感器的遥测读取器/充电器设备		
公开(公告)号	US20020077672A1	公开(公告)日	2002-06-20
申请号	US09/739575	申请日	2000-12-18
[标]申请(专利权)人(译)	GOVARI阿萨夫 本哈伊姆SHLOMO ZILBERSTEIN JOEL		
申请(专利权)人(译)	GOVARI阿萨夫 BEN-HAIM SHLOMO ZILBERSTEIN JOEL		
当前申请(专利权)人(译)	GOVARI阿萨夫 BEN-HAIM SHLOMO ZILBERSTEIN JOEL		
[标]发明人	GOVARI ASSAF BEN HAIM SHLOMO ZILBERSTEIN JOEL		
发明人	GOVARI, ASSAF BEN-HAIM, SHLOMO ZILBERSTEIN, JOEL		
IPC分类号	A61B5/07 A61B5/00 A61N1/08		
CPC分类号	A61B5/0031 Y10S128/903 A61B2560/0219 A61B5/0215 A61B5/076 A61B5/6882		
其他公开文献	US6658300		
外部链接	Espacenet USPTO		

摘要(译)

一种与可植入遥测医疗传感器一起使用的信号读取和充电装置，包括壳体和壳体内部的电路，该电路包括逻辑控制单元和处理单元。逻辑控制单元向遥测医疗传感器发送供电信号，以远程为传感器供电。逻辑控制单元还接收来自传感器的发送信号。处理单元可操作地连接到控制单元，用于将传感器发送的信号转换成测量参数。天线线圈用于发送供电信号并从传感器接收发送的信号。该设备还包括用于显示测量参数的显示器。

