



US008062228B2

(12) **United States Patent**
Carr

(10) **Patent No.:** **US 8,062,228 B2**

(45) **Date of Patent:** **Nov. 22, 2011**

(54) **DUAL MODE INTRACRANIAL TEMPERATURE DETECTOR**

(75) Inventor: **Kenneth L. Carr**, Woolwich, ME (US)

(73) Assignee: **Meridian Medical Systems, LLC**, Woolrich, ME (US)

(*) Notice: Subject to any disclaimer, the term of this patent is extended or adjusted under 35 U.S.C. 154(b) by 779 days.

(21) Appl. No.: **11/773,056**

(22) Filed: **Jul. 3, 2007**

(65) **Prior Publication Data**

US 2009/0012417 A1 Jan. 8, 2009

(51) **Int. Cl.**
A61B 5/00 (2006.01)

(52) **U.S. Cl.** **600/549**; 374/122; 600/407

(58) **Field of Classification Search** 600/407, 600/549; 374/121, 122

See application file for complete search history.

(56) **References Cited**

U.S. PATENT DOCUMENTS

3,265,993	A *	8/1966	Davidson et al.	333/1
4,647,281	A *	3/1987	Carr	604/503
5,461,394	A *	10/1995	Weber	343/786
5,549,639	A *	8/1996	Ross	607/101
2003/0067367	A1 *	4/2003	Volman	333/125
2004/0243004	A1	12/2004	Carr	

OTHER PUBLICATIONS

Stec et al. "Multifrequency Microwave Thermograph for Biomedical Applications" IEEE 2004. submitted by applicant.*

Hand et al. "Monitoring of deep brain temperature in infants using multi-frequency microwave radiometry and thermal modelling" Physics in Medicine and Biology 2001. pp. 1885-1888.*

"Notification of Transmittal of the International Search Report and the Written Opinion of the International Searching Authority, or the Declaration", International Application No. PCT/US2008/008206, issued by European Patent Office, Mail Date Nov. 13, 2008, 15 pages. Dobrowolski et al., "Multifrequency Microwave Thermograph for Biomedical Applications", IEEE Transactions on Biomedical Engineering, IEEE Service Center, Piscataway, New Jersey, vol. 51, No. 3, Mar. 1, 2004, 4 pages. Maruyama et al., "Feasibility of Noninvasive Measurement of Deep Brain Temperature in Newborn Infants by Multifrequency Radiometry", IEEE Transactions on Microwave Theory and Techniques, IEEE Service Center, Piscataway, New Jersey, vol. 48, No. 11, Nov. 1, 2000, 7 pages.

* cited by examiner

Primary Examiner — Max Hindenburg

Assistant Examiner — Renee Danega

(74) *Attorney, Agent, or Firm* — Cesari and McKenna, LLP; John F. McKenna

(57) **ABSTRACT**

Apparatus for detecting thermal radiation emanating from two different intracranial depths in a patient includes a dual-mode transducer having a working surface for placement against a patient's cranium. The transducer includes a first antenna with an aperture adjacent the working surface that first antenna being tuned to a first frequency and producing a first output signal indicative of thermal radiation received within an antenna pattern extending a selected first distance from the working surface and a second antenna having a second aperture adjacent to the working surface within the first aperture. The second antenna is tuned to a second frequency and produces a second output signal indicative of thermal radiation received within an antenna pattern extending a selected second distance from the working surface, the second distance being shorter than the first distance. The two output signals are coupled to a receiver/control unit which thereupon monitors and displays the temperature at the two intracranial depths.

29 Claims, 8 Drawing Sheets

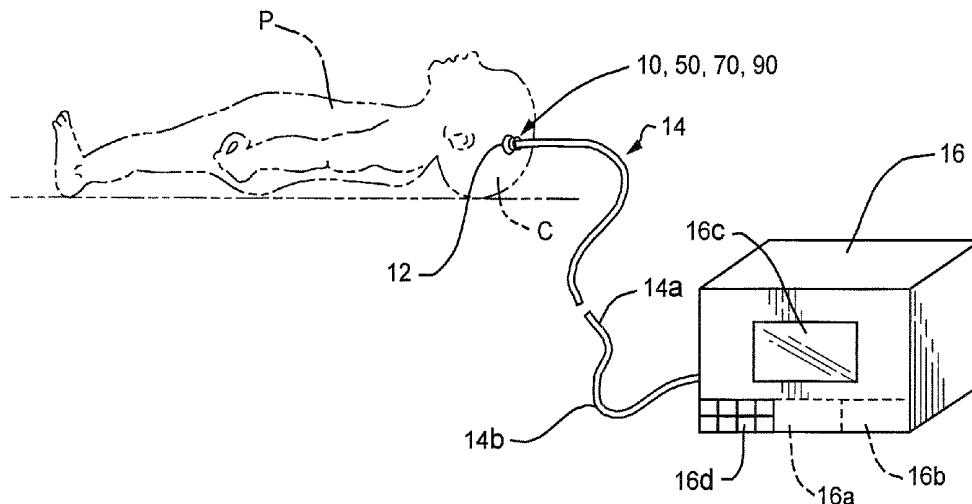

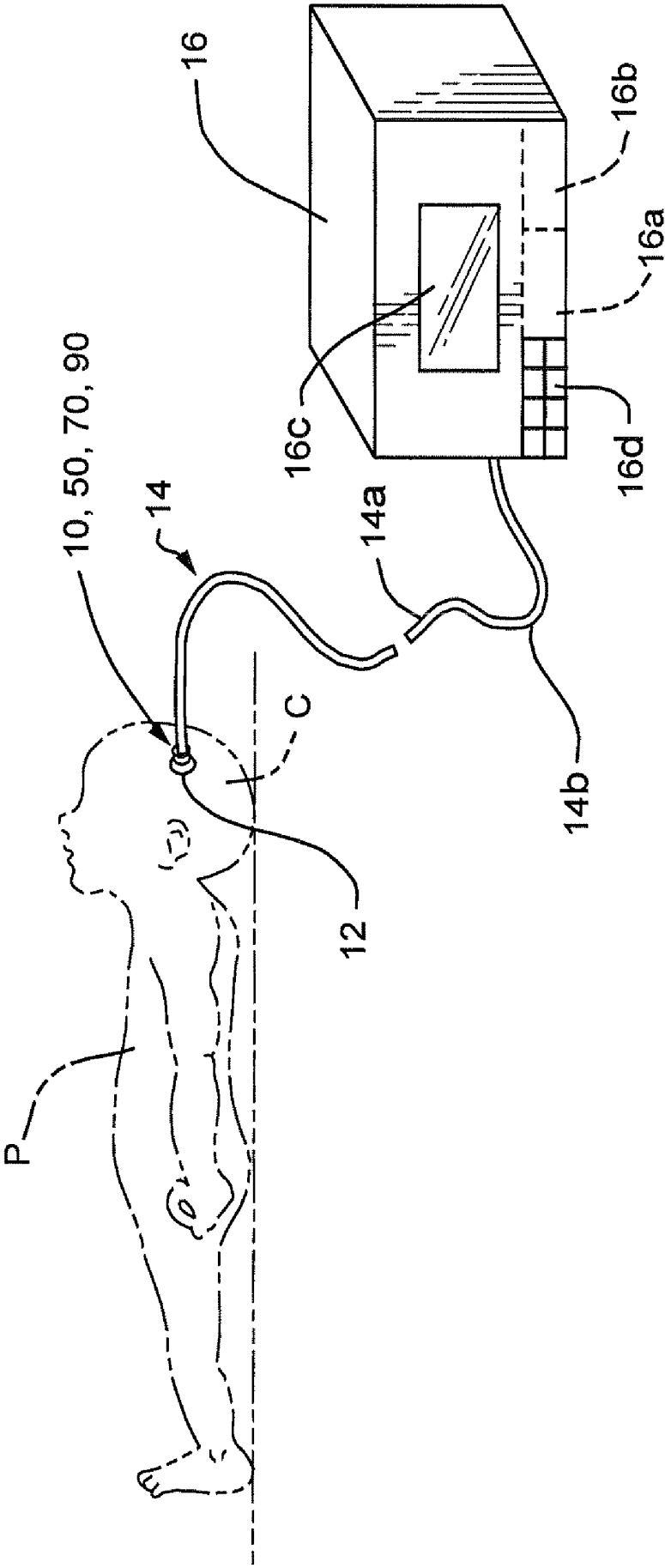

FIG. 1

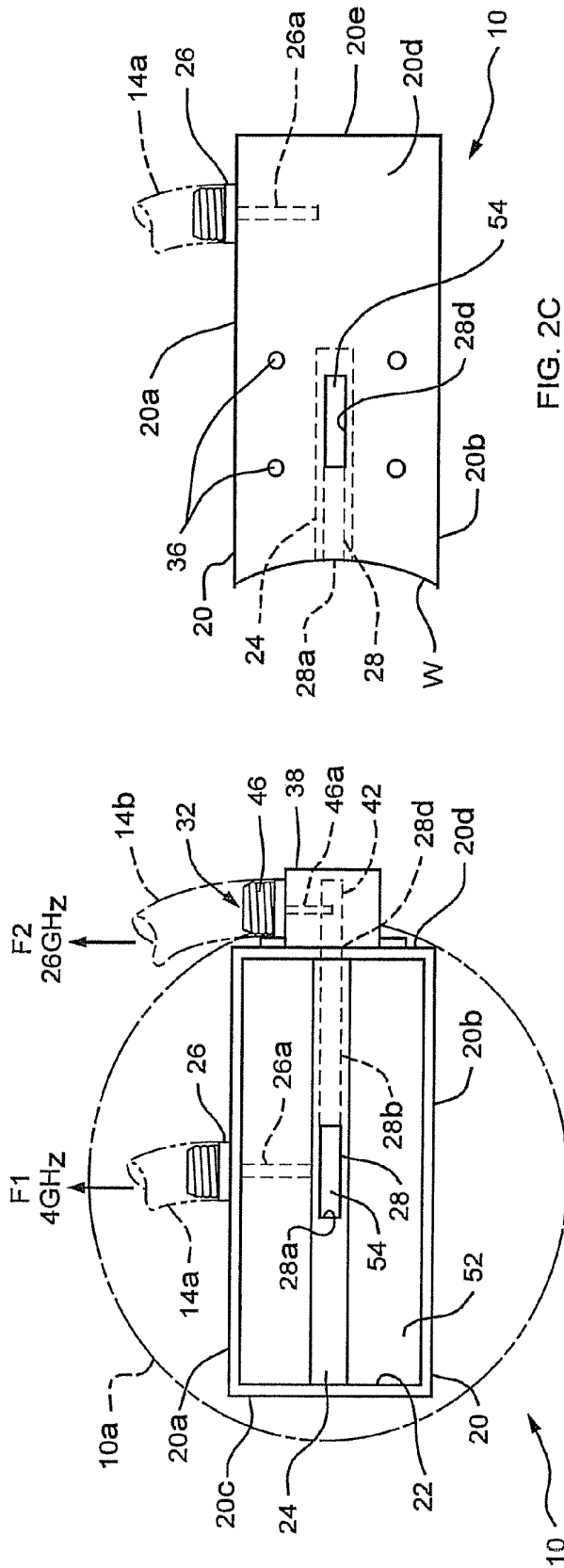

FIG. 2C

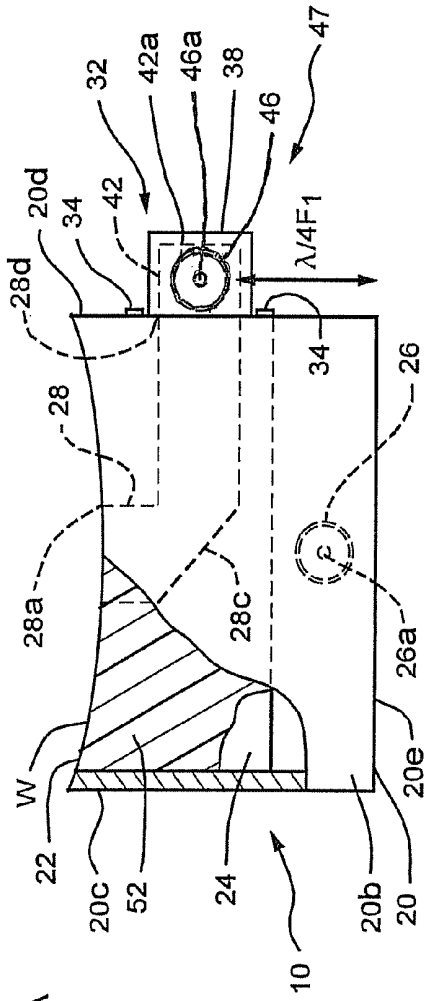

FIG. 2B

FIG. 2A

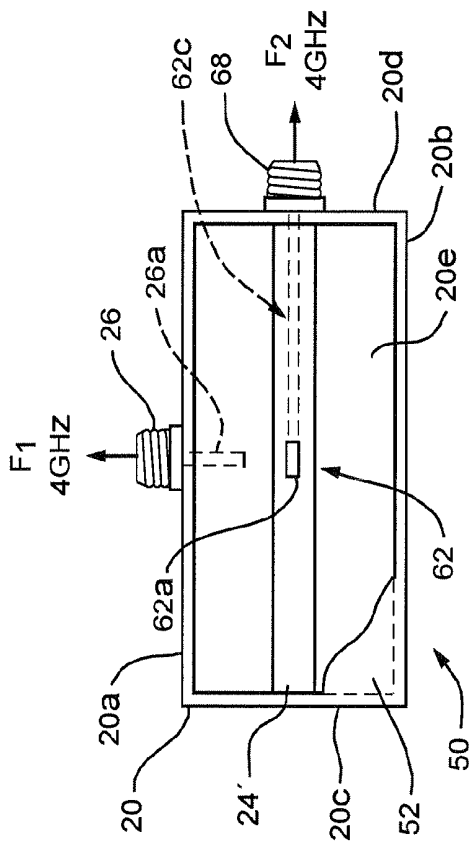

FIG. 3A

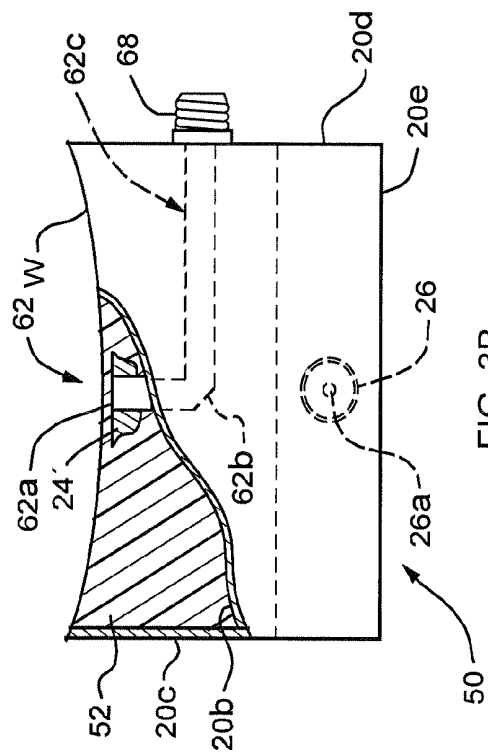

FIG. 3B

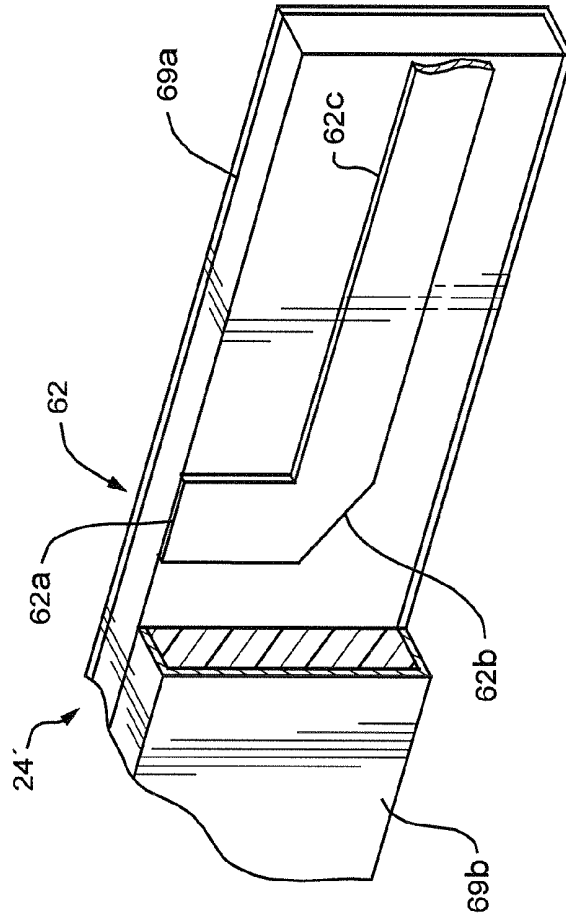

FIG. 3C

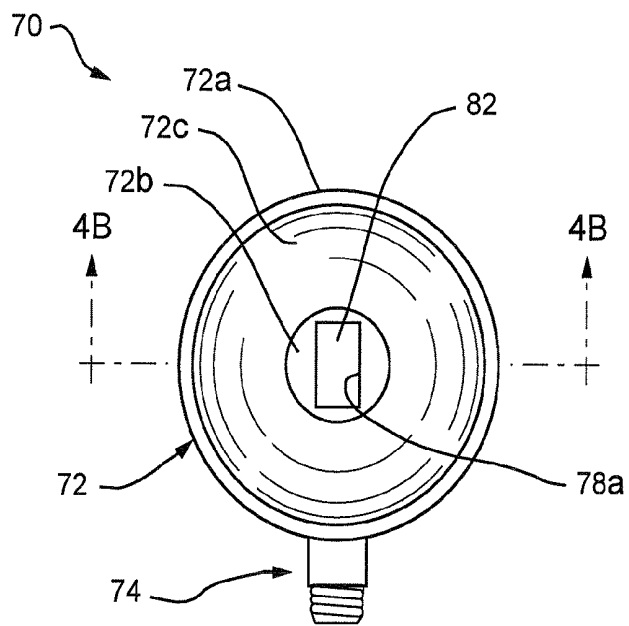

FIG. 4A

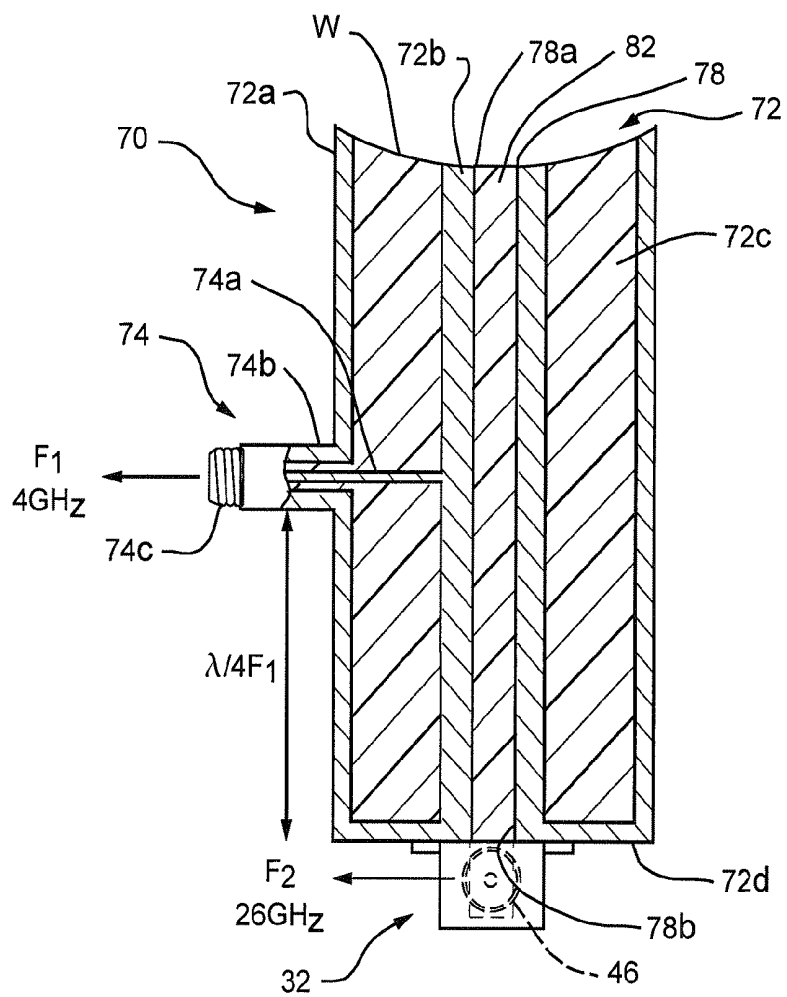

FIG. 4B

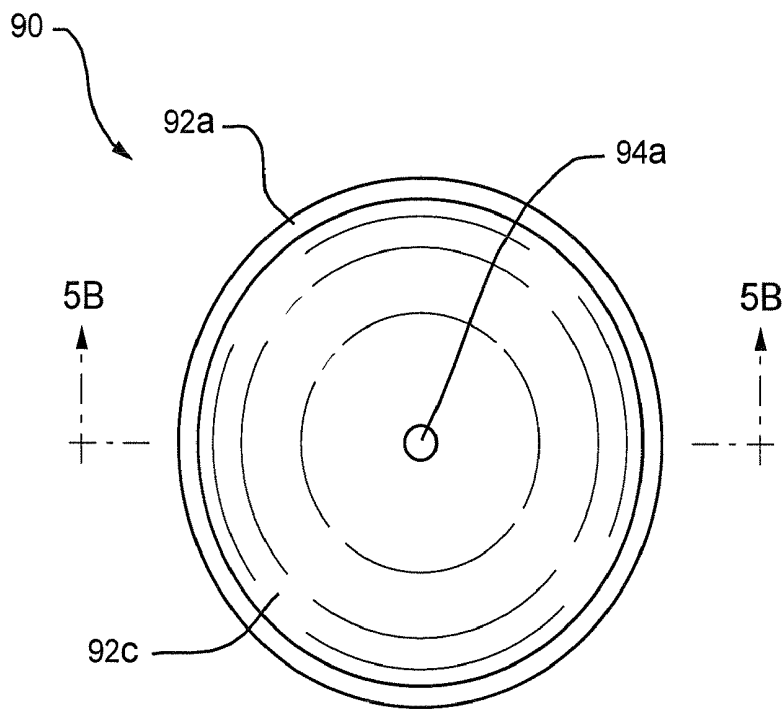

FIG. 5A

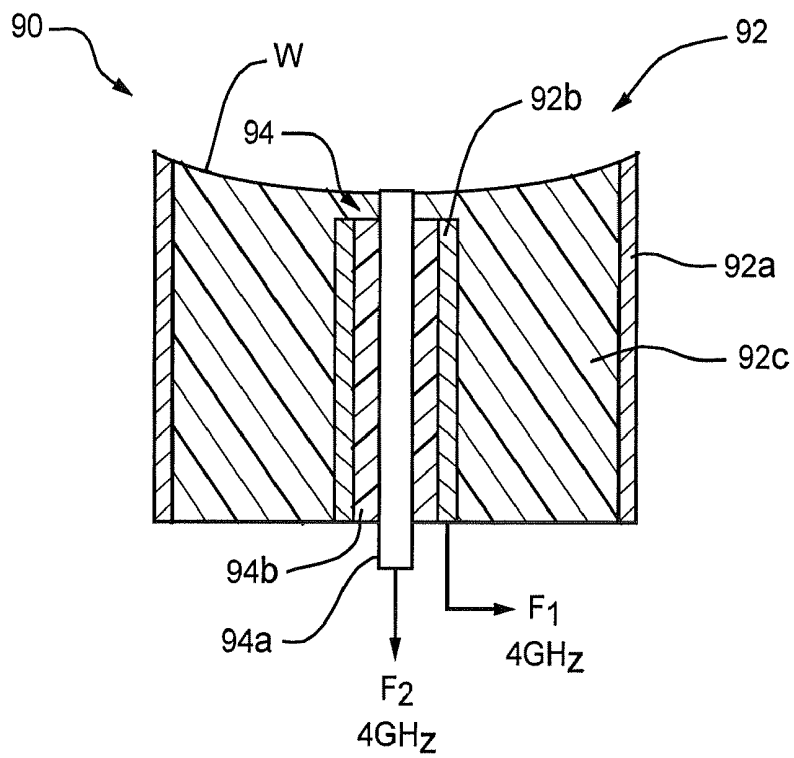

FIG. 5B

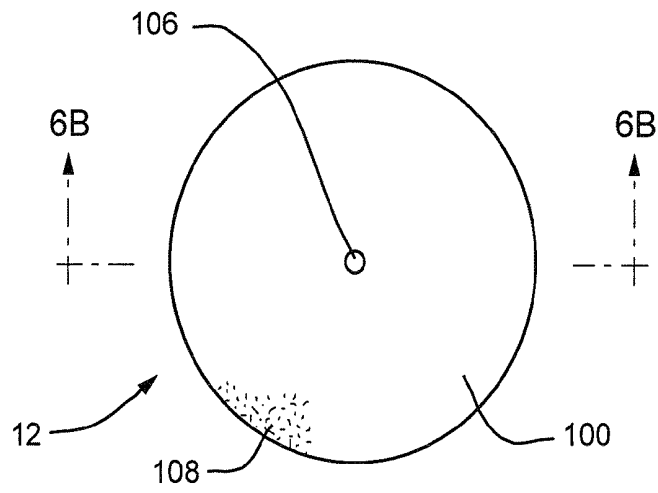

FIG. 6A

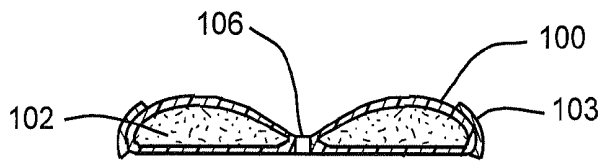

FIG. 6B

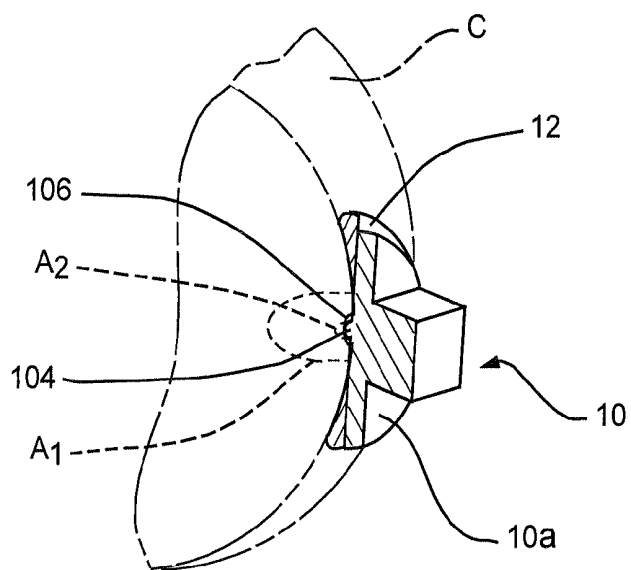

FIG. 6C

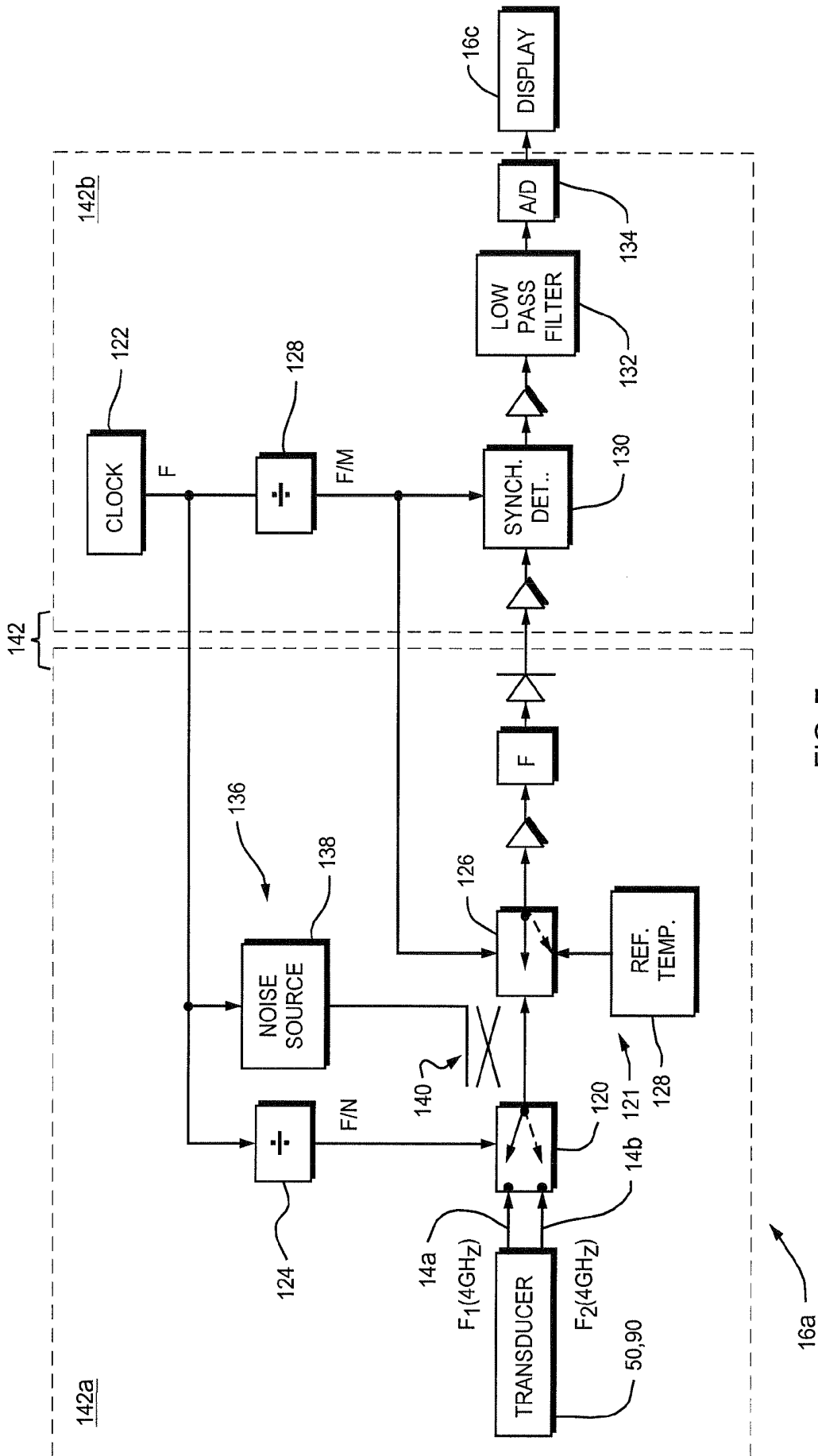

FIG. 7

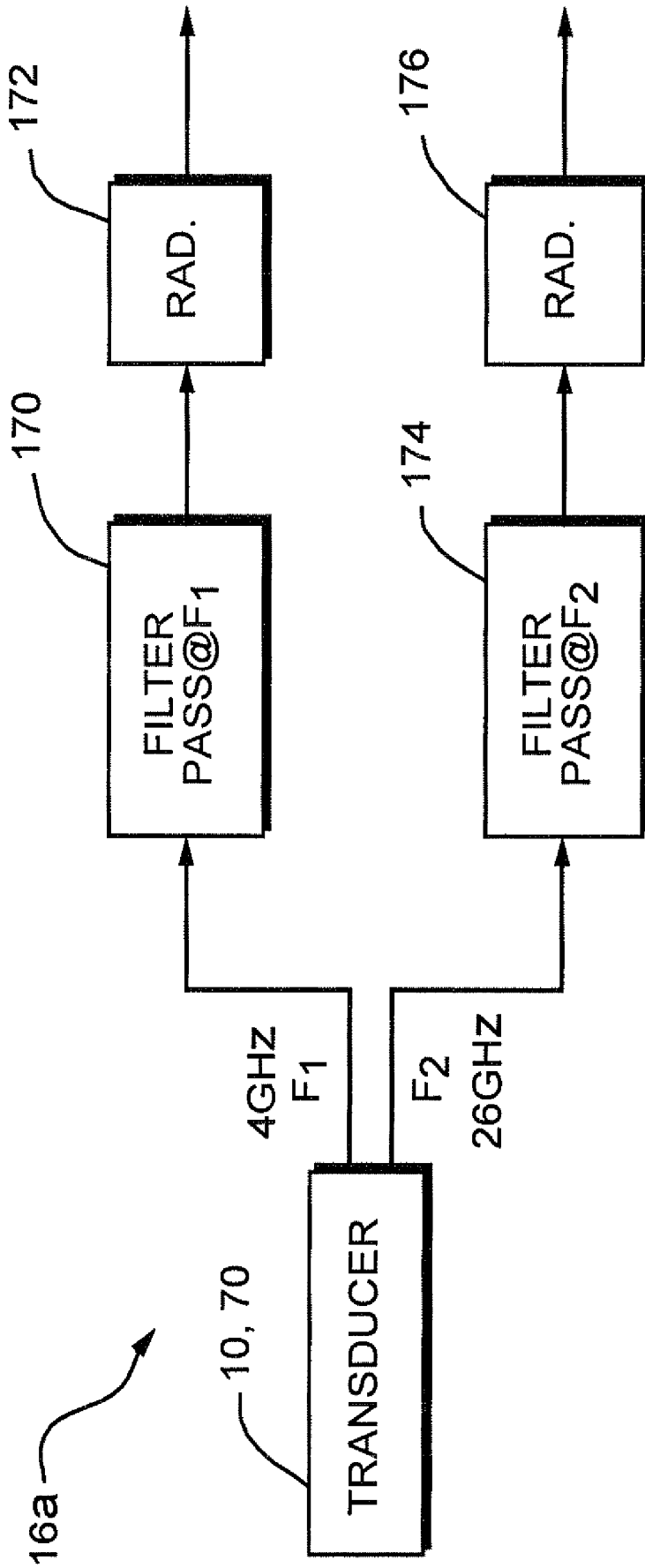

FIG. 8

DUAL MODE INTRACRANIAL TEMPERATURE DETECTOR

BACKGROUND OF THE INVENTION

1. Field of the Invention

This invention relates to temperature monitoring apparatus using microwave radiometry. It relates more particularly to apparatus for non-invasively and reliably detecting and monitoring the temperature of target brain tissue especially in neonatal patients.

2. Background Information

Hypoxic-ischemia or asphyxia is a serious problem in newborns. Lack of an adequate supply of oxygenated blood to the brain may result in serious brain injury called hypoxic-ischemic encephalopathy (HIE). It is estimated that HIE occurs in about 3-9 newborns out of 1,000 term infants. About half of these infants with HIE (range of 35-50%) will die or suffer from severe handicaps such as mental retardation or cerebral palsy.

At the present time, beyond the initial care given to the newborn in the delivery room to provide artificial breathing or medications, there is no standard care to lessen HIE. Multi-centered trials are currently underway in the United States and elsewhere to measure the safety and efficacy of hypothermia in reducing brain injury events following periods of low oxygen to the brain. The objective is to cool the brain by 4-33° with an accuracy of about 0.20° C. Sorely needed, then, is a non-invasive sensor which can reliably detect and monitor temperature of the target brain tissue.

Currently, trials effecting hypothermic cooling of the head or systemic hypothermia utilize rectal temperature as an indirect index of the infant's brain temperature. However, while performing hypothermia, it is necessary not only to control brain temperature but also to control the rate of cooling, as well as the rate to re-warm the brain. Such close control cannot be maintained by measuring temperature at a remote site such as the rectum.

It is also possible to measure deep brain temperature non-invasively using magnetic resonance spectroscopy, but the cost and feasibility are big problems with this approach considering the need for continuous 72-hour thermal monitoring of each newborn in a ferromagnetic-free environment, followed by a 16-24 hour re-warming period, bringing the total time for each hypothermia procedure to about 96 hours.

The monitoring of axillary esophageal and nasopharyngeal temperatures to indicate intracranial temperature has also been considered. However, these areas like the rectal area are slow in indicating thermal trends in the brain.

There are also available devices based on infrared (IR) technology which may be placed in the ear. The tympanic membrane temperature is considered a more reliable indicator of brain temperature than oral or rectal readings because it is closer to the brain. However, these so-called tympanic devices, although relatively inexpensive, are still not considered sufficiently accurate for this application. This is because such devices show an inability to deliver an accurate temperature reading for various reasons such as wax and moisture in the ear which are absorptive at IR frequencies. Also, such devices actually measure radiation from the ear canal wall and the environment within the ear canal resulting in a lower temperature reading than would be obtained from the tympanic membrane itself. Still further, the available IR devices are physically large and therefore not suited for the ear of a neonatal patient who, as noted above, may require continuous monitoring for many hours. Finally, commercially available

IR devices do not read below 34° C., while the preferred temperature range for intracranial cooling is 32.8-33.0° C.

In sum, the prior apparatus are disadvantaged in that they do not measure the brain parenchymal tissue directly but rather rely on indirect temperature measurements on other parts of the body and they do not also measure the surface temperature at the cranium thereby allowing the patient's skin to be over-cooled during the hypothermic treatment.

Accordingly, it would be desirable to provide apparatus for reliably detecting and monitoring brain temperature at depth as well as near surface temperature directly but non-invasively during long-term hypothermic treatment to reduce the incidence of brain injury particularly in neonates.

SUMMARY OF THE INVENTION

Accordingly, it an object of the present invention to provide apparatus for directly detecting and routinely monitoring intracranial temperature non-invasively in patients, particularly neonates, using microwave radiometry.

Another object of the invention is to provide such apparatus which measures not only intracranial temperature at depth but also surface temperature to prevent the patient's skin from getting too cold during hypothermic treatment.

A further object of the invention is to provide apparatus of this type incorporating a miniature dual mode transducer which may be affixed easily to the head of an infant or neonate.

Yet another object is to provide such a transducer which, while being used over a long period, does not cause discomfort to the patient.

Still another object of the invention is to provide such apparatus in which at least part of the associated radiometric receiver may be integrated into the transducer that is affixed to the patient.

Another object of the invention is to provide apparatus of this type which includes a disposable radiometer coupling device to provide a sterile and intimate interface between the transducer and the patient's skin.

An additional object is to provide apparatus such as this which includes provision for ensuring the effectiveness of the coupling of the transducer to the patient.

Other objects will, in part, be obvious and will, in part, appear hereinafter. The invention accordingly comprises the features of construction, combination of elements and arrangement of parts which will be exemplified in the following detailed description, and the scope of the invention will be indicated in the claims.

Briefly, the present apparatus comprises a miniature dual mode transducer containing a pair of antennas capable of detecting the near surface temperature of a patient's cranium as well as the temperature at depth therein. By "near surface temperature" it is meant the temperature of the tissue between the skull and the skin surface which, based on available data, is approximately 2 mm. By "temperature at depth" it is meant the temperature of brain parenchymal tissue at a depth of at least 15 mm. Preferably, the transducer is quite small so that it can be affixed easily to the head of a neonate and remain there for a prolonged period without causing discomfort to the patient.

The present transducer for the measurement of brain temperature is, basically, an aperture shared by two antennas. One antenna is used to measure temperature at depth, while the second antenna is used to measure temperature at or near the surface. The second antenna may be located in a septum which bisects the aperture. The introduction of the septum has been found to have little, if any, effect on the receive pattern

of the aperture. The determination of surface temperature may be displayed by an associated display as "surface" or "skin temperature", but this data may also be used to enhance the ability of the apparatus to predict temperature at depth.

The apparatus may also incorporate a disposable coupler which provides an intimate sterile interface between the transducer and the patient's skin. This ensures that the transducer is positioned properly on the patient's head with no air gaps between it and the patient's skin so that electromagnetic radiation passes efficiently between the head and the transducer.

Finally, the apparatus may include a radiometric receiver/control unit which responds to the dual outputs from the transducer to provide indications of the near surface temperature and the temperature at depth. As we shall see, at least parts of the receiver/control unit may be incorporated into the transducer and the unit may include a unique noise injection reflectometer which provides a measure of the quality of placement of the transducer against the patient's head.

The dual mode transducer may have antennas of various forms. One transducer embodiment comprises a waveguide antenna tuned to a first frequency. The waveguide is partitioned internally by a septum containing a second waveguide antenna tuned to a second, higher, frequency, the two antennas being capable of detecting thermal radiation reflecting the temperature at depth and the near surface temperature, respectively. A second transducer embodiment includes a similar waveguide with septum but having a small antenna in the septum which is tuned to the same frequency as the waveguide in order to detect the two temperatures. A third version of the dual mode transducer is of a triaxial construction. It comprises a relatively large diameter outer coaxial cable antenna tuned to a first frequency with a waveguide transducer within the center conductor of the cable, the waveguide being tuned to a second, higher, frequency to detect the two aforesaid temperatures. A fourth transducer version also includes an outer coaxial cable antenna but with a smaller inner antenna in the center conductor of the larger antenna, both antennas being tuned to the same frequency.

When coupled to a radiometric receiver/control unit, all of the above transducer embodiments enable the reliable and continuous long term detection and monitoring of near surface temperature and temperature at depth in a patient's cranium.

BRIEF DESCRIPTION OF THE DRAWINGS

For a fuller understanding of the nature and objects of the invention reference should be made to the following detailed description taken in connection with the accompanying drawings, in which:

FIG. 1 is a diagrammatic view of a dual mode temperature monitoring apparatus incorporating the invention;

FIG. 2A is a front bottom view of a dual mode transducer comprising the FIG. 1 apparatus;

FIG. 2B is a front view with parts broken away thereof;

FIG. 2C is a side view thereof;

FIG. 3A is a front bottom view of a second embodiment of the transducer;

FIG. 3B is front view with parts broken away thereof;

FIG. 3C is a fragmentary perspective view with parts broken away on a larger scale showing a part of the FIG. 3A transducer in general detail;

FIG. 4A is a front bottom view of a third embodiment of the dual mode transducer;

FIG. 4B is a sectional view taken along line 4B-4B of FIG. 4A;

FIG. 5A is bottom view of a fourth embodiment of the transducer;

FIG. 5B is a sectional view taken along line 5B-5B of FIG. 5A;

FIG. 6A is a bottom view on a larger scale of the coupler comprising the FIG. 1 apparatus;

FIG. 6B is a sectional view taken along line 6B-6B of FIG. 6A;

FIG. 6C is a diagrammatic view in section on a much larger scale showing the transducer and coupler in the FIG. 1 apparatus;

FIG. 7 is a block diagram of a radiometric receiver that may comprise the receiver/control unit in the FIG. 1 apparatus, and

FIG. 8 is a similar diagram of a second receiver embodiment.

DETAILED DESCRIPTION OF ILLUSTRATIVE EMBODIMENTS

Referring to FIG. 1 of the drawings, my apparatus includes a dual-mode transducer shown generally at 10 which may be removeably affixed to the cranium C of a patient P such as a neonate. Preferably, a conformable coupling member 12 is interposed between the transducer 10 and the patient's skin to provide an intimate coupling between the two which is substantially devoid of air gaps. As we shall see, transducer 10 contains a pair of microwave antennas capable of detecting thermal radiation originating from two different depths in the patient's cranium and producing corresponding output signals which are coupled via a cable 14 to a receiver/control unit 16. That unit includes a radiometric receiver 16a which, under the control of a controller 16b, produces output signals which reflect two intracranial temperatures in the patient P, namely, the temperature at depth, and the near surface temperature. Unit 16 may also include a display 16c which responds to those signals to provide a visible indication of the two temperatures. Display 16c may also display other parameters such as the date and start time of the hypothermic procedure, elapsed time, ambient temperature, patient's pulse rate, apparatus diagnostics, etc. Unit 16 may be turned on and off and controlled by way of a keypad 16d. As we shall see later, in some embodiments of the apparatus, of the receiver 16a may be incorporated right into the transducer.

Referring now to FIGS. 2A-2C, transducer 10 may comprise a first antenna in the form of a generally rectangular waveguide 20 composed of a pair of mirror-image broader walls 20a and 20b, a pair of mirror-image narrower walls 20c and 20d and an end or rear wall 20e. Spaced opposite the end wall 20e is a front opening or aperture 22 which is bounded by the edges of walls 20a-20d. The aperture and its boundary constitutes the working surface W of the transducer and it may be slightly concave as shown in FIGS. 2B and 2C so that it more or less follows the curvature of the patient's cranium.

In accordance with the invention, waveguide 20 includes a septum 24 which extends between walls 20c and 20d so as to partition aperture 22. The septum essentially bifurcates the waveguide 20 with little if any impact on the antenna pattern of the waveguide. Preferably the septum 24 extends from the working surface W toward end wall 20e a distance that allows for a coaxial connector 26 to be mounted to wall 20a so that its probe 26a can extend into waveguide 20 a sufficient distance to provide a waveguide-to-conductor transition that can couple electromagnetic energy to and from the waveguide 20.

In accordance with the invention, a second antenna in the form of a second, much smaller, waveguide 28 is present in septum 24. As best seen in FIG. 2B, the two waveguides are coaxial and waveguide 28 has an aperture 28a and extends

down into septum **24** where it connects to a lateral waveguide segment **28b** via a compact H plane right angle bend **28c**. Segment **28b** extends along septum **24** to a port **28d** formed in the waveguide wall **20d**. It is apparent, then, that the depth of septum **24** in waveguide **20** should be greater than the length of waveguide aperture **28a** so that the septum can accommodate waveguide segment **28b**.

As depicted in FIGS. **2A** and **2B**, the transducer **10** also includes a transition unit **32** which may be mounted to the waveguide wall **20d** by threaded fasteners **34** turned down into threaded holes **36** in that wall. Unit **32** has been removed in FIG. **2C** so that the holes **36** are visible there.

The transition unit **32** comprises a housing **38** in which there is formed a waveguide extension **42** having an entrance aligned with port **28d** in the waveguide wall **20d**. The waveguide extension **42** includes an end wall **42a** spaced opposite port **28d** and which constitutes an end wall for the waveguide **28** as a whole. A coaxial connector **46** is mounted to the side of housing **38** so that its center conductor or probe **46a** projects into waveguide extension **42** adjacent to its end wall **42a**. Thus, electromagnetic energy may be coupled to and from waveguide **28** via the transition unit **32**.

In accordance with the invention, the waveguides **20** and **28** are tuned to two different frequencies. More particularly, waveguide **20** operates at a relatively low frequency F_1 , e.g. 4 GHz. Consequently, it has a relatively large antenna pattern A_1 (FIG. **6C**) which extends an appreciable distance from the waveguide aperture **22** and the working surface W , i.e. at least 15 mm. On the other hand, waveguide **28** is tuned to a much higher frequency F_2 , e.g. 26 GHz, so that its antenna pattern A_2 (FIG. **6C**), which is within the envelope of pattern A_1 , extends a much shorter distance from surface W , i.e. about 2 mm. In order to minimize the size of a transducer **10** operating at these frequencies, the waveguide **20** is preferably filled with a dielectric material **52** out to surface W . This reduces the waveguide size by the square root of the dielectric constant ϵ_r of that material. For example, a 4 GHz waveguide **20** having an aperture **22** that is 3.84×1.59 cm may be filled with Delrin® acetal resin having a dielectric constant ϵ_r of 3.8. This provides a return loss of 15 dB over the typical 3.75 to 4.2 GHz range of a receiver **16a** in control unit **16** (FIG. **1**). The waveguide **28**, operating at 26 GHz, on the other hand, may have an aperture **28a** that is 0.13 by 0.38 cm and be filled with Teflon® tetrafluoroethylene resin having a dielectric constant of 2.1. This antenna provides a return loss of 20 dB for a receiver **16a** having a frequency range of 25 to 27 GHz.

In order to separate the two different frequency signals from the waveguide antennas, the probe **46a** is spaced from the end wall **20e** of waveguide **20** a distance equal to a quarter wavelength (or integral multiple thereof) at the frequency F_1 . This forms a quarter wave diplexer **47** as shown in FIG. **2B** that is integrated into transducer **10**.

If desired, the waveguide **20** may be mounted within a circular base or flange as shown in phantom at **10a** in FIG. **2A** so that the transducer has the general shape of a large aspirin tablet that can be affixed easily to the cranium C of the patient P as shown in FIG. **1**.

The cable **14** depicted in that same figure actually comprises a pair of coaxial cables **14a** and **14b** releasably connected to connectors **26** and **46**, respectively. As will be described in more detail later, cables **14a** and **14b** couple the two output signals F_1 and F_2 from transducer **10** to a pair of radiometers in receiver **16a** of receiver/control unit **16** to provide the temperature at depth and near surface temperature indications that are displayed by that unit's display **16c**.

Refer now to FIGS. **3A** to **3C** which illustrate a second transducer embodiment shown generally at **50** for use in the

FIG. **1** apparatus. This embodiment incorporates two antennas tuned to the same frequency, but which are still able to detect the near surface temperature and the temperature at depth in the patient's cranium C . One, outer, antenna in transducer **50** is a waveguide **20** that may be identical to the one described in connection with FIGS. **2A-2C**, except that it has a septum **24'** that contains, as a second, inner antenna, a stripline **62** having an open end that constitutes an antenna aperture **62a** in the middle of the septum at working surface W .

The coaxial cable segment **62** extends down into septum **24'** where it transitions via a right angle bend **62b** to a lateral segment **62c** connected to a SMA connector **68** (e.g. Tensolite™ 5678-5CC) mounted to the wall **20d** of waveguide **20**.

In this embodiment **50**, the two antennas, i.e. waveguide **20** and stripline **62**, may operate at the same frequency, i.e. $F_1=F_2=4$ GHz, with the stripline **62** having a shorter antenna pattern than that of the waveguide **20** by virtue of its much smaller aperture **62a**. In some applications, the antenna in septum **24'** may be a coaxial antenna instead of a stripline.

As with the first transducer embodiment **10**, the two antennas are coupled by cable **14** to receiver/control unit **16**. However, since they operate at the same frequency, their outputs may be time shared with a single radiometer in receiver **16a** of unit **16** to be described, enabling the unit **16** to display the near surface temperature and the temperature at depth in the patient's cranium C . For the same reason, transducer **50** does not require a diplexer.

The septum **24'** in transducer **50** may actually comprise two circuit boards **69a** and **69b** positioned side by side as shown in FIG. **3C**, the thickness of the boards being exaggerated for clarity. Actually, each circuit board is only in the order of 0.32 inch thick with copper cladding **70** (0.007 inch) on the outboard face and perhaps some edges of the boards to constitute a ground plane. The stripline **62** is printed on circuit board **69a** as a copper trace having a thickness of about 0.007 inch. Preferably, the circuit boards **69a**, **69b** are Duroid™ boards having a dielectric constant of 10.

Refer now to FIGS. **4A** and **4B** which illustrate a third transducer embodiment shown generally at **70**. In FIG. **4B**, the length of the device is exaggerated for ease of illustration. This embodiment includes a first antenna comprising a coaxial cable segment **72** having an outer conductor **72a** and an inner conductor **72b** separated by the usual dielectric material **72c**. The cable segment **72** extends from a coaxial aperture at working surface W to a short-circuiting end wall **72d** spaced from that aperture. It is tuned to frequency F_1 . The temperature at depth signal detected by antenna **72** is outputted by a coaxial transmission line **74** consisting of a first conductor **74a** connected to inner conductor **72b** and a second conductor **74b** connected to outer conductor **72a**, the transmission line ending in a connector **74c**.

In accordance with the invention, conductor **72b** contains a second, coaxial, antenna comprising a length of waveguide **78** which extends from an aperture **78a** at working surface W to a port **78b** in end wall **72d**. Preferably, the waveguide **78** is filled with a dielectric material **82** to minimize the size of the waveguide as described above. In order to output the signal from waveguide **78**, a transition unit **32** similar to the one described above in connection with transducer **10** is mounted to the end wall **72d** opposite the waveguide port **78b**. The output from unit **32** present at its connector **46** is a signal F_2 , e.g. 26 GHz, corresponding to the near surface temperature detected by the transducer **70**. As with the transducer **10**, the transmission line **74** is spaced from end wall **72d** a distance corresponding to a quarter wavelength (or integral multiple thereof) at frequency F_1 . The coaxial portion of antenna **72**

and line 74 forms a stub support which achieves a right angle bend. The waveguide 78 continues on to transition 32 forming a quarter wave stub. This structure thus constitutes a diplexer that serves to separate the two output signals F_1 and F_2 . The operation of the transducer is thus similar to that of transducer 10.

In FIGS. 5A and 5B, a fourth transducer embodiment is shown generally at 90. It comprises a pair of outer and inner coaxial cable antennas 92 and 94 arranged in a triaxial configuration. Antenna 92 comprises an outer conductor 92a, e.g. 2.03 cm OD, and an inner conductor 92b, e.g. 0.79 cm OD, separated by a dielectric material 92c. The antenna 94 is contained within the inner conductor 92b and is composed of a center conductor 94a separated from conductor 92b by a dielectric material 94b. The coaxial apertures of antennas 92 and 94 are located at the transducer's working surface W. In this embodiment, the two antennas are tuned to the same frequency, e.g. $F_1=F_2=4$ GHz. Due to its relatively large diameter, the antenna 94 has a characteristic antenna pattern which extends in the order of 15 mm from that working surface. The antenna 94, on the other hand, with its much smaller diameter has a characteristic antenna pattern which is within the envelope of the larger pattern but projects only about 2 mm from that surface.

The transducer 90 operates in a manner similar to that of transducer 50. It is advantaged in that it can have a low profile because it does not require a waveguide-to-conductor transition. In addition, it is fully shielded from external radiation sources, e.g. fluorescent lights. Also, since both antennas operate at the same frequency, it requires only one radiometer in the receiver 16a of its unit 16 (FIG. 1).

Proper placement of the transducers 10, 50, etc. with respect to the patient's cranium C is a primary concern. The coupling member 12 which is shown in detail in FIGS. 6A and 6B helps to accomplish this. Preferably, the coupling member is a disposable sterile article comprising a small, thin wall conformable plastic pouch or bag 100 containing a filler 102 which may be a fluid, a dielectric powder or a combination of both. The coupling member or coupler 12 should have more or less the same size and shape as the transducer working surface W so that it serves as a cushion that conforms to the patient's cranium C and the surface W as shown in FIG. 6C, ensuring that no significant air gaps exist between the two.

The illustrated filler 102 is of titanium dioxide which has a dielectric constant ϵ_r of approximately 10 in powder form. Such a dielectric constant provides a good transition between the transducer and the patient's skin. This lower constant also reduces the possibility of interference since a lower ϵ_r will, in essence, reduce (in terms of microwave path) the gap created between the transducer and the cranium by the coupler 12. Adding a slight contour to the working surface W as shown in the drawing figures further reduces this gap.

It is also been found that the ϵ_r value will be increased with the addition of, for example, mineral oil which has a dielectric constant of 4 coupled with a low loss tangent. This, in essence, displaces any air having an ϵ_r value of 1 in the pouch 102 with a fluid whose corresponding value is 4. Adding other powders with a lower ϵ_r will likewise reduce the overall ϵ_r .

Ideally, the thickness of the coupling member 12 at the center of the working surface W should be minimal, e.g. the opposite walls of bag 100 may be welded together at the center of the pouch, with the thickness of the coupler gradually increasing radially so that its outer edge has a thickness in the order of 3.8 mm (based on a typical neonate head diameter of 12.7 cm). In some applications, it may be desirable to metallize the rim of pouch 100 as shown at 103 in FIG. 6B to provide shielding in order to minimize interference from

outside radiation sources. Also, if a filler 102 in powder form is used, it is important that the powder does not settle out within the pouch 100. To avoid this, the pouch 100 may have a sponge-like interior impregnated with a filler 102 consisting of a fluid-powder combination as above.

As shown in FIG. 6C, the surface W may be formed with a small bump 104 at its center and the pouch 100 may have at its center a corresponding hole 106 with a welded edge so that the bump and hole may interfit to center the coupler with respect to the transducer. Alternatively, the transducer working surface can be formed with a center dimple adapted to receive a bump centered on the coupler to achieve the same objective.

In use, it may be desirable to releasably affix the coupler 12 to the transducer working surface W and/or to the patient's cranium C. This may be accomplished by covering part or all of the outer surface of the pouch 100 with a low tack adhesive as indicated by the stippling 108 in FIG. 6A. Of course, attachment to the patient's cranium could also be accomplished through the use of a surgical dressing such as one sold under the brand name "Op-Site" which is used in many hospital neonate units.

As noted above, the two dual mode transducers 50 and 90 are advantaged in that both antennas therein operate at the same frequency, e.g. $F_1=F_2=4$ GHz. Therefore, the receiver/control unit 16 associated therewith requires only one radiometer in receiver 16a which may be time shared by the two antennas. Thus, as shown in FIG. 7, the outputs from the two antennas of transducer 50 or 90 may be applied to a receiver 16a including a two-position switch 120 followed by a more or less conventional Dicke-type radiometer having a bandwidth that includes 4 GHz and is shown generally at 121. A radiometer of this type is disclosed in my U.S. Pat. No. 4,557,272 whose contents are incorporated by reference herein. That switch may be controlled by signals from a clock 122 which are applied to the switch by way of a divider 124 so as to switch the two transducer outputs to the radiometer at a selected relatively low frequency F/N, e.g. 0.1 Hz.

The alternate signals from switch 120 are applied to one input of the radiometer's Dicke switch 126 which also receives, at a second input, a signal from the radiometer's reference temperature source 128. The Dicke switch may be controlled by signals from clock 122 which are applied to that switch via a divider 128, or more usually by the radiometer directly so that the Dicke switch 126 is switched at a selected much higher frequency F/M, typically 60 Hz. The output from the Dicke switch is amplified and filtered before being applied to the radiometer's synchronous detector 130 that is controlled by the same signals that toggle the Dicke switch 126. The detector output is integrated over a desired period and fed via a low pass filter 132 to an A/D converter 134 whose output may be applied by controller 16b to the display 16c in control unit 16 so that the display displays the near surface temperature and the temperature at depth detected by the transducer 50 or 90.

It will be appreciated from the foregoing that the larger antenna in each transducer 10, 50, 70, 90 which detects thermal radiation from a brain tissue volume at depth also detects a thermal contribution from the volume near the surface that is sensed by the smaller antenna in each transducer. This is because the smaller antenna pattern A_2 is located within the envelope of the larger antenna pattern A_1 (FIG. 6C). Preferably, the controller 16b uses the radiometer data associated with the smaller antenna to make a correction to the radiometer data associated with the larger antenna that will compensate for the above near surface volume contribution to the

measured temperature at depth to produce a true temperature at depth measurement, i.e. a brain core temperature measurement.

Typical brain temperature behavior as a function of depth may be expressed as follows:

$$T = T_{core} - (T_{core} - T_{surf})e^{(d/cf)} \quad (1)$$

where d=intracranial depth
cf=cooling factor

Using electromagnetic simulations, a transducer depth weighting factor (wf) may be provided which is the fractional contribution of the total received noise power (temperature) by intracranial depth.

The temperature profile may then be integrated over the weighting factor wf as follows:

$$T_{radiometer} = \int_{surface}^{\infty} \{T \times wf\} d \quad (2)$$

to provide an expression for the temperature indication from the total at depth tissue volume. Knowing the near surface temperature and the indicated temperature at depth, the controller **16b** can compute the brain core temperature for display by display **16c**.

In order to ensure that the transducer and the coupling member **12** are positioned properly on the patient's cranium, the receiver **16a** preferably includes a coupler placement monitor in the form of a noise injection reflectometer shown generally at **136** in FIG. 7. The reflectometer comprises a noise source **138** that responds to the signals F from clock **122** to produce wide band microwave noise which is coupled via a coupler **140** onto the radiometer **121** input at Dicke switch **126** and is directed out through the larger antenna in transducer **50** or **90**.

The presence of an impedance mismatch due to a poor coupling of the transducer to the patient's cranium C will cause a portion of the noise power to reflect back into the radiometer **121** where it is detected. For example, a return loss of 10 db would correspond approximately to a mismatch of 1.9 to 1 and a 90% transmission. The noise source **138** is toggled on and off by signals F from clock **122** and, in more or less the same way as the Dicke switch **126** compares the input temperature from the transducer to the reference temperature from source **128**, the reflected noise is compared to the absence of reflected noise to determine a reflection coefficient. This provides a reflection measurement that may be integrated over the detection bandwidth and weighted by the band limiting characteristics of the radiometer by controller **16b**. That reflection measurement may be also displayed by display **16c** to apprise the operator of the quality of placement of the transducer on the cranium C.

While the receiver **16a** shown in FIG. 7 is contained in the control unit **16**, at least some of its components could be incorporated into the associated transducer. In this event, the FIG. 7 receiver may be implemented as a monolithic microwave integrated circuit (MMIC) chip **142**. Such a solid state chip is so small that it may be mounted on a transducer wall, e.g. wall **20a** in FIG. 3A, or it may be placed in the transducer base **10a** (FIG. 2A). In this event, the antenna connectors, e.g. connectors **26** and **68** in FIG. 3A, may be replaced by stripline connections to the chip **142**. Also in some cases, the receiver circuit is formed as two separate MMIC chips **142a** and **142b** as shown in FIG. 7, the former being incorporated into the transducer, the latter being in unit **16**. This simplifies manu-

facture of the overall circuit **142** and minimizes feedback between the chip components.

In contrast to transducers **50** and **90**, the transducers **10** and **70** described above each produce dual outputs at frequencies F_1 and F_2 that are different. Therefore, the receiver **16a** associated with those transducers requires two radiometers as shown in FIG. 8. As seen there, the transducer output signal F_1 is coupled to a band pass filter **170** which passes that signal to a radiometer **172** having a bandwidth which includes frequency F_1 . Similarly, the transducer output signal F_2 is fed to a second band pass filter **174** which applies that signal to a second radiometer **176** whose bandwidth includes the frequency F_2 . The outputs from the two radiometers may then be applied via suitable amplifiers and A/D converters (not shown) to provide input signals for display **16c** so that the display indicates the near surface temperature and the temperature at depth sensed by the transducer **10** or **70**.

It will be thus seen that the objects set forth at the outset, among those made apparent from the preceding description, are efficiently attained. Also, certain changes may be made in the above constructions without departing from the scope of the invention. For example, in the transducers **10** and **70**, the waveguide-to-conductor transition unit **32** may be substituted for by stripline or a waveguide-to-waveguide transition unit that extends to receiver/control unit **16**. Therefore, it is intended that all matter contained in the above description or shown in the accompanying drawings shall be interpreted as illustrative and not in a limiting sense.

It is also to be understood that the following claims are intended to claim all of the generic and specific features of the invention described herein.

I claim:

1. Apparatus for long term monitoring of the intracranial temperature of a neonate, said apparatus comprising a dual-mode transducer including

a working surface whose area constitutes a small percentage of the cranial surface of the neonate;

a first antenna in the form of a rectangular waveguide having a pair of opposite broad walls and a pair of opposite narrower walls, said waveguide extending along an axis to a first end defining a first aperture at or near said working surface, said first antenna having a characteristic first antenna pattern that extends a selected first distance outward along said axis from said working surface and being tuned to a first frequency, said first antenna producing a first output signal indicative of thermal radiation from a selected depth in the neonate's cranium;

a continuous septum extending between opposite locations on the narrower walls so as to partition the waveguide along its length without appreciably affecting the first antenna pattern, and

a second antenna located substantially entirely within the septum and extending from a first end at a connection outside the waveguide to a second end located on said axis adjacent to said working surface and defining a second aperture which is shared with the first aperture, said second antenna having a characteristic second antenna pattern that extends a selected second distance less than the first distance outward along said axis from said working surface and being tuned to a second frequency, said second antenna producing a second output signal indicative of thermal radiation from the near surface of the neonate's cranium.

2. The apparatus defined in claim 1 wherein the second antenna comprises a second waveguide having a second aperture constituting said second end, and

11

said second frequency is appreciably higher than the first frequency.

3. The apparatus defined in claim 2 wherein the first waveguide contains a material having a selected first dielectric constant, and

the second waveguide contains a material having a selected second dielectric constant.

4. The apparatus defined in claim 3 wherein the first and second dielectric constants are different.

5. The apparatus defined in claim 2 and further including a first transition extending from the first waveguide to the outside of the transducer for outputting said first output signal, and

a second transition extending from the second waveguide to the outside of the transducer for outputting said second output signal.

6. The apparatus defined in claim 5 wherein the second transition is spaced from said closed end of the first waveguide a distance substantially equal to a quarter wavelength or integral multiple thereof at said first frequency.

7. The apparatus defined in claim 6 wherein at least one of the first and second transitions comprises a waveguide-to-coaxial conductor transition.

8. The apparatus defined in claim 6 wherein at least one of said first and second transitions comprises a waveguide-to-waveguide transition.

9. The apparatus defined in claim 6 wherein at least one of the first and second transitions comprises strip line.

10. The apparatus defined in claim 1 wherein the second antenna comprises a transmission line including a conductor which extends from said working surface to the outside of the transducer to output said second output signal.

11. The apparatus defined in claim 10 wherein said first and second frequencies are substantially the same.

12. The apparatus defined in claim 10 wherein the transmission line comprises a coaxial cable.

13. The apparatus defined in claim 10 wherein the transmission line comprises stripline.

14. The apparatus defined in claim 10 wherein the septum comprises

a pair of circuit boards positioned flush against one another, and

the second antenna includes a circuit path printed on at least one circuit board and extending between both circuit boards.

15. The apparatus defined in claim 1 wherein said working surface is concave and is composed mainly of a dielectric material.

16. The apparatus defined in claim 1 and further including a conformable coupling device having a selected dielectric constant and for placement between said working surface and said cranium for coupling electromagnetic energy between the two.

12

17. The apparatus defined in claim 16 wherein the coupling device comprises a flexible pouch at least partially filled with a dielectric material.

18. The apparatus defined in claim 17 wherein said working surface and said pouch are circular and the pouch is thinner at its center than at its edge.

19. The apparatus defined in claim 18 and further including an electrically conductive coating at the pouch edge.

20. The apparatus defined in claim 17 wherein said working surface and said pouch have interfitting surfaces for centering the pouch on the working surface.

21. The apparatus defined in claim 17 and further including a low tack adhesive outer coating on at least part of the pouch.

22. The apparatus defined in claim 1 wherein said first and second frequencies are different, and further including a first radiometer having an input and a frequency range encompassing said first frequency, said first radiometer receiving at its input said first output signal and producing an indication of the temperature at one of said two intracranial depths and a second radiometer having an input and a frequency range encompassing said second frequency, said second radiometer receiving at its input said second output signal and producing an indication of the temperature at the other of said two intracranial depths.

23. The apparatus defined in claim 1 wherein said first aperture has a maximum dimension less than 4 cm.

24. The apparatus defined in claim 1 wherein the selected first distance is about 2 mm and the selected second distance is about 15 mm.

25. The apparatus defined in claim 1 and further including a dielectric material filling the available space within the waveguide out to said working surface.

26. The apparatus defined in claim 1 wherein said first and second frequencies are substantially the same, and

further including a radiometer having an input and a frequency range encompassing the first and second frequencies, and a switch connected between the transducer and said input for switching said first and second output signals alternately to said radiometer input, said radiometer producing alternate outputs indicative of the respective temperatures at said selected depth and near surface.

27. The apparatus defined in claim 26 wherein the radiometer comprises at least one MMIC mounted to the transducer.

28. The apparatus defined in claim 26 and further including a noise injection reflectometer coupled to said radiometer input.

29. The apparatus defined in claim 26 and further including a device for correcting the radiometer output associated with the first antenna to compensate for the contribution thereto of the radiometer output associated with the second antenna to produce a true brain core temperature measurement.

* * * * *

专利名称(译)	双模式颅内温度检测仪		
公开(公告)号	US8062228	公开(公告)日	2011-11-22
申请号	US11/773056	申请日	2007-07-03
[标]申请(专利权)人(译)	默里蒂安医疗系统有限责任公司		
申请(专利权)人(译)	MERIDIAN医疗系统有限责任公司		
[标]发明人	CARR KENNETH L		
发明人	CARR, KENNETH L.		
IPC分类号	A61B5/00		
CPC分类号	A61B5/015 A61B5/4076 G01K11/006		
其他公开文献	US20090012417A1		
外部链接	Espacenet USPTO		

摘要(译)

用于检测从患者的两个不同颅内深度发出的热辐射的装置包括双模式换能器，其具有用于放置在患者颅骨上的工作表面。换能器包括第一天线，其具有邻近工作表面的孔，第一天线被调谐到第一频率并产生第一输出信号，该第一输出信号表示在从工作表面延伸选定的第一距离的天线图案内接收的热辐射和第二天线在第一孔内具有与工作表面相邻的第二孔。第二天线被调谐到第二频率并产生第二输出信号，该第二输出信号指示在从工作表面延伸选定的第二距离的天线图案内接收的热辐射，第二距离短于第一距离。两个输出信号耦合到接收器/控制单元，接着/控制单元随后监视并显示两个颅内深度的温度。

