



(19) **United States**

(12) **Patent Application Publication**
Labounty et al.

(10) **Pub. No.: US 2001/0044823 A1**

(43) **Pub. Date: Nov. 22, 2001**

(54) **INTRANET-BASED MEDICAL DATA DISTRIBUTION SYSTEM**

Publication Classification

(51) **Int. Cl.⁷** **G06F 15/16**
(52) **U.S. Cl.** **709/203**

(76) Inventors: **Scott Labounty**, Orange, CA (US);
David R. Clark, Irvine, CA (US);
Darryn A. Johnnie, Brea, CA (US)

(57) **ABSTRACT**

A network based medical telemetry system that uses, to the greatest extent possible, standard hardware and software components. The system allows clinicians using computers anywhere in a large hospital to view physiologic data from patients of the hospital. Each patient is fitted with a set of sensors that measure physiologic properties of the patient (e.g., EKG sensors). The sensors are connected to a transmitter that relays the physiologic data to a central server. The central server comprises a WEB server that supplies basic patient data such as the patient's name and medical history. The central server also comprises a waveform server which supplies the physiologic data, in real-time or near real-time. Workstation, used by a clinician receives the basic patient data from the Web server and the physiologic data from the waveform server, and produces a combined display. The combined display is continuously updated, showing, for example, the patient's EKG.

Correspondence Address:
KNOBBE MARTENS OLSON & BEAR LLP
620 NEWPORT CENTER DRIVE
SIXTEENTH FLOOR
NEWPORT BEACH, CA 92660 (US)

(21) Appl. No.: **09/818,072**

(22) Filed: **Mar. 27, 2001**

Related U.S. Application Data

(63) Non-provisional of provisional application No. 60/192,510, filed on Mar. 28, 2000.

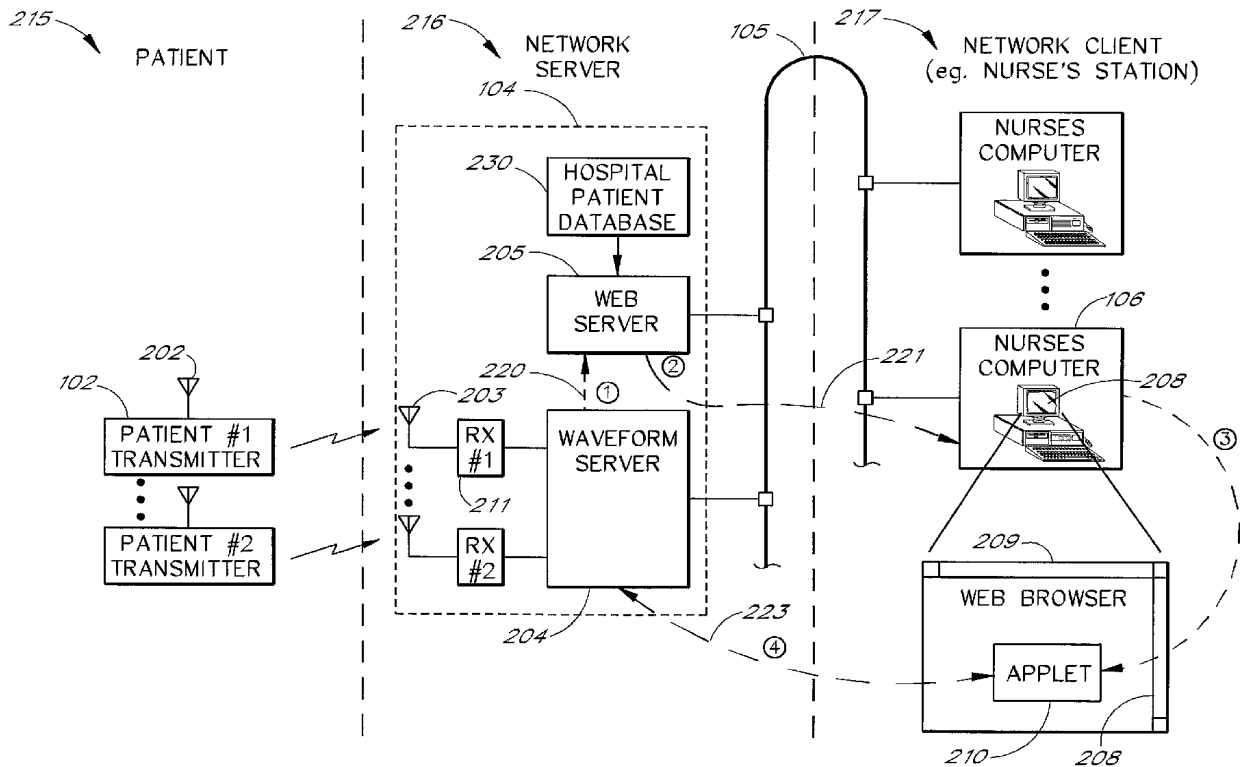

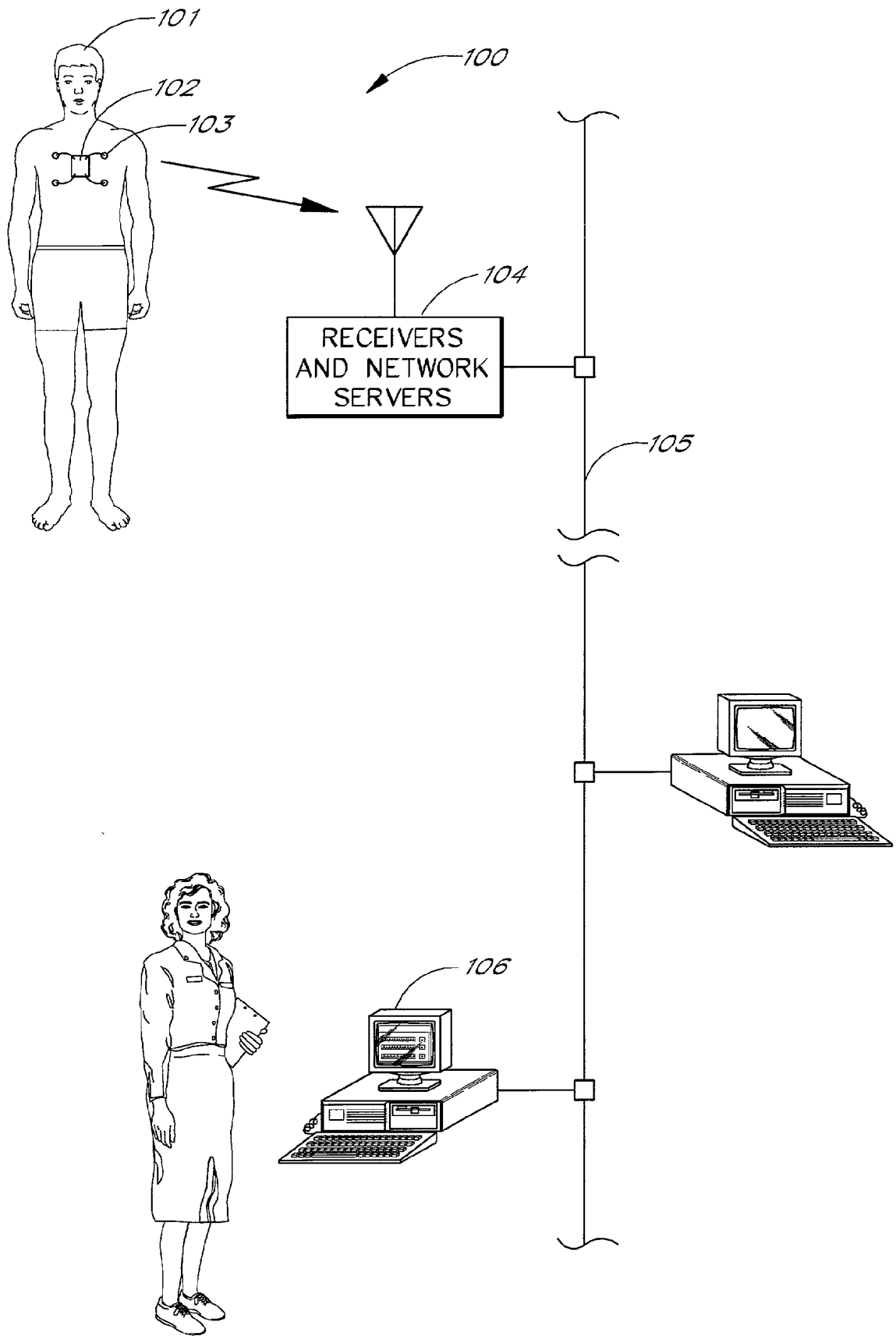

FIG. 1

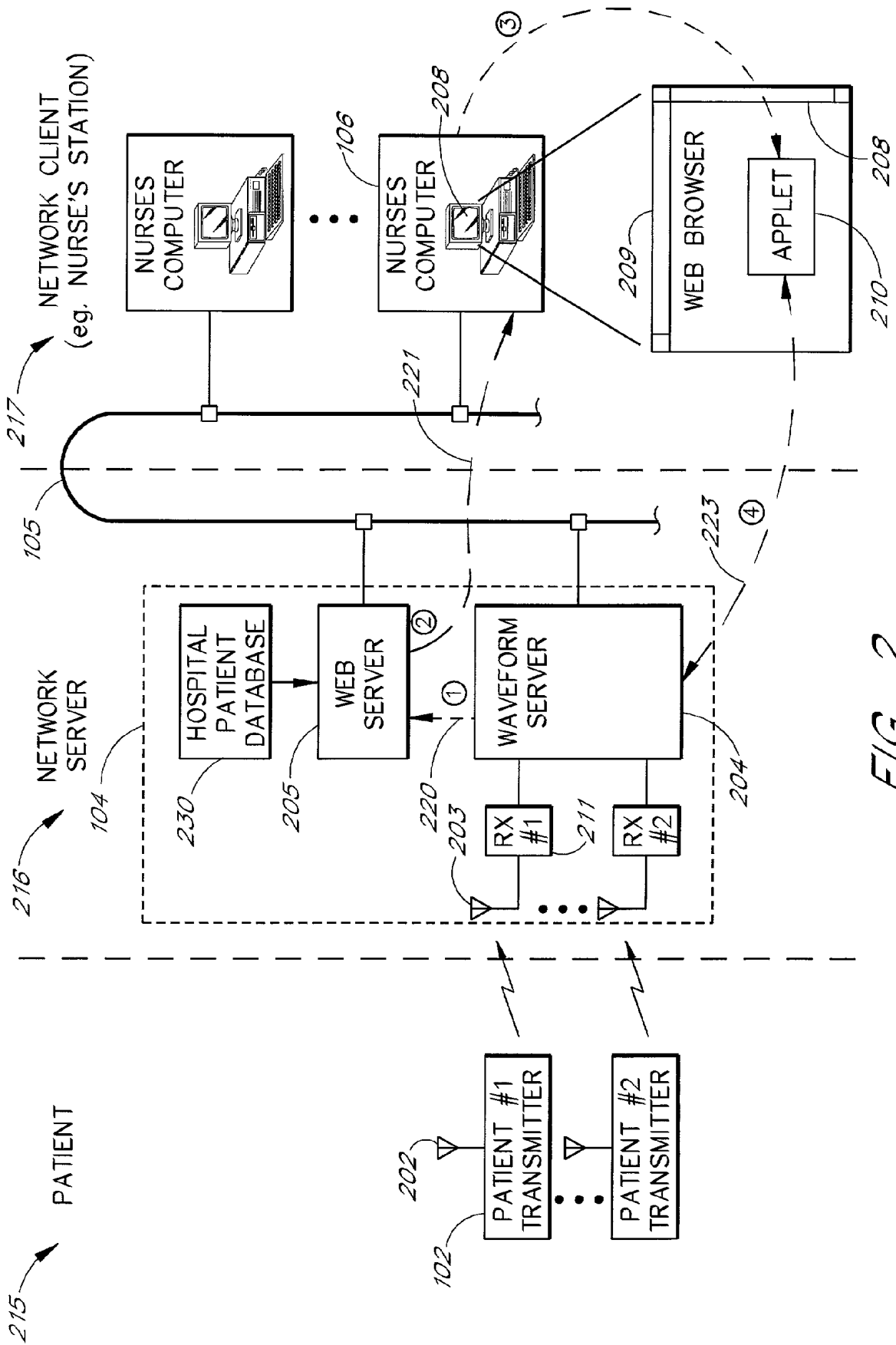

FIG. 2

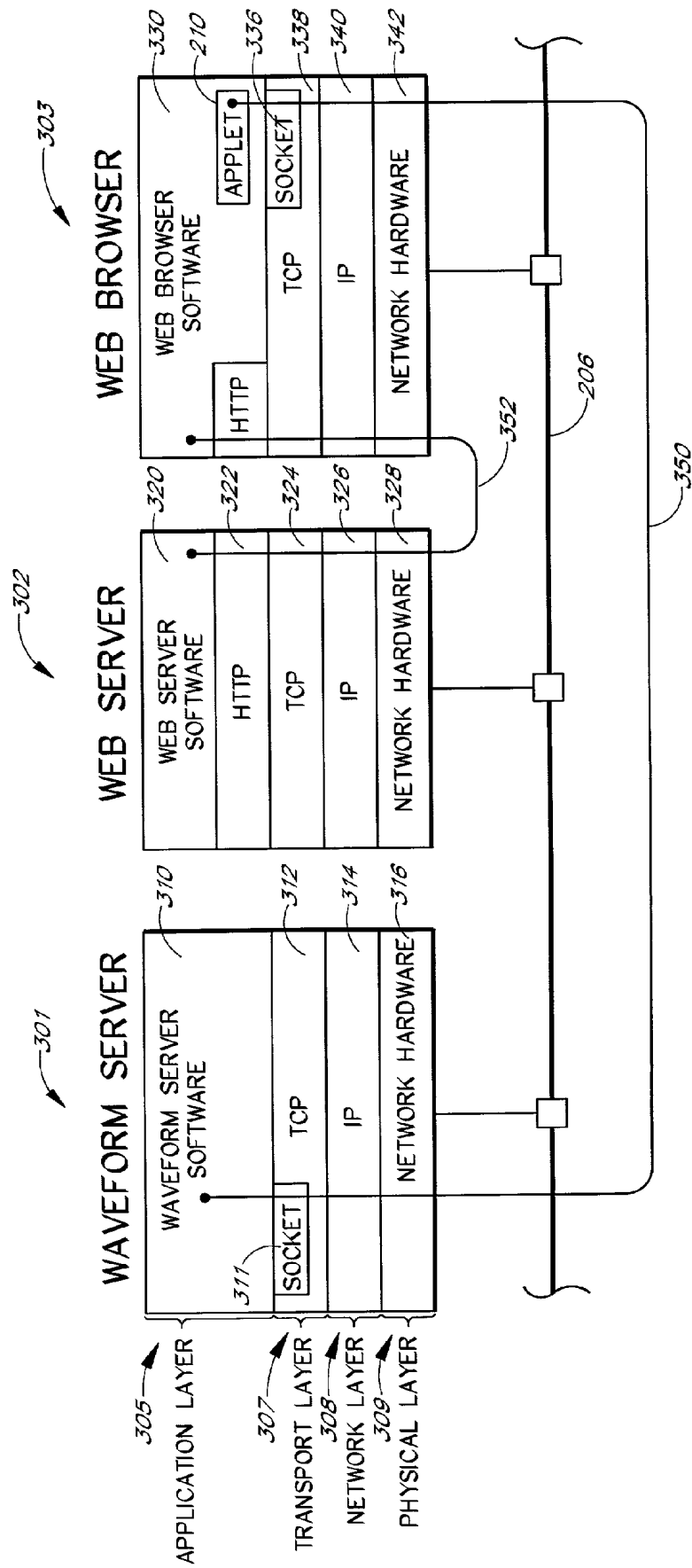

FIG. 3

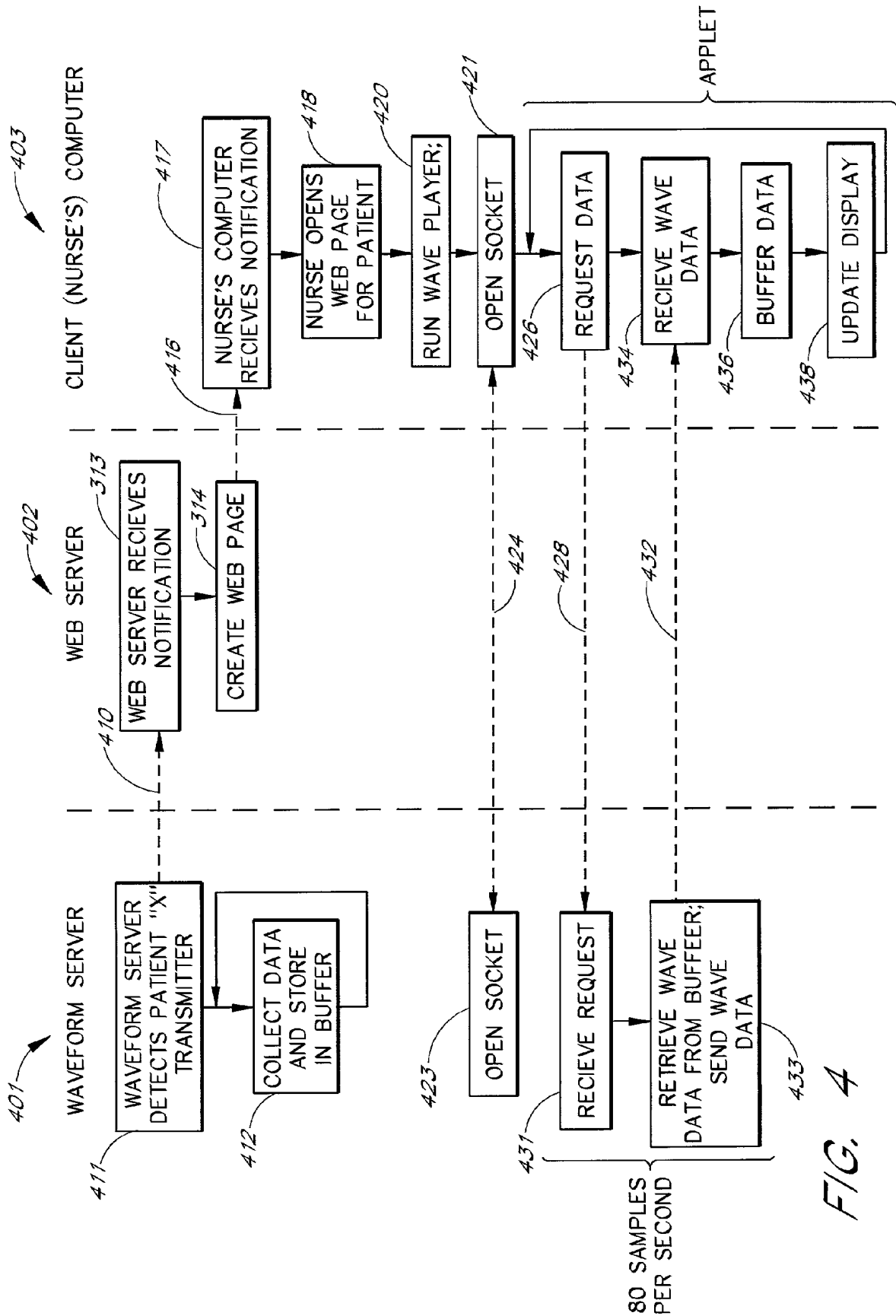

FIG. 4

501

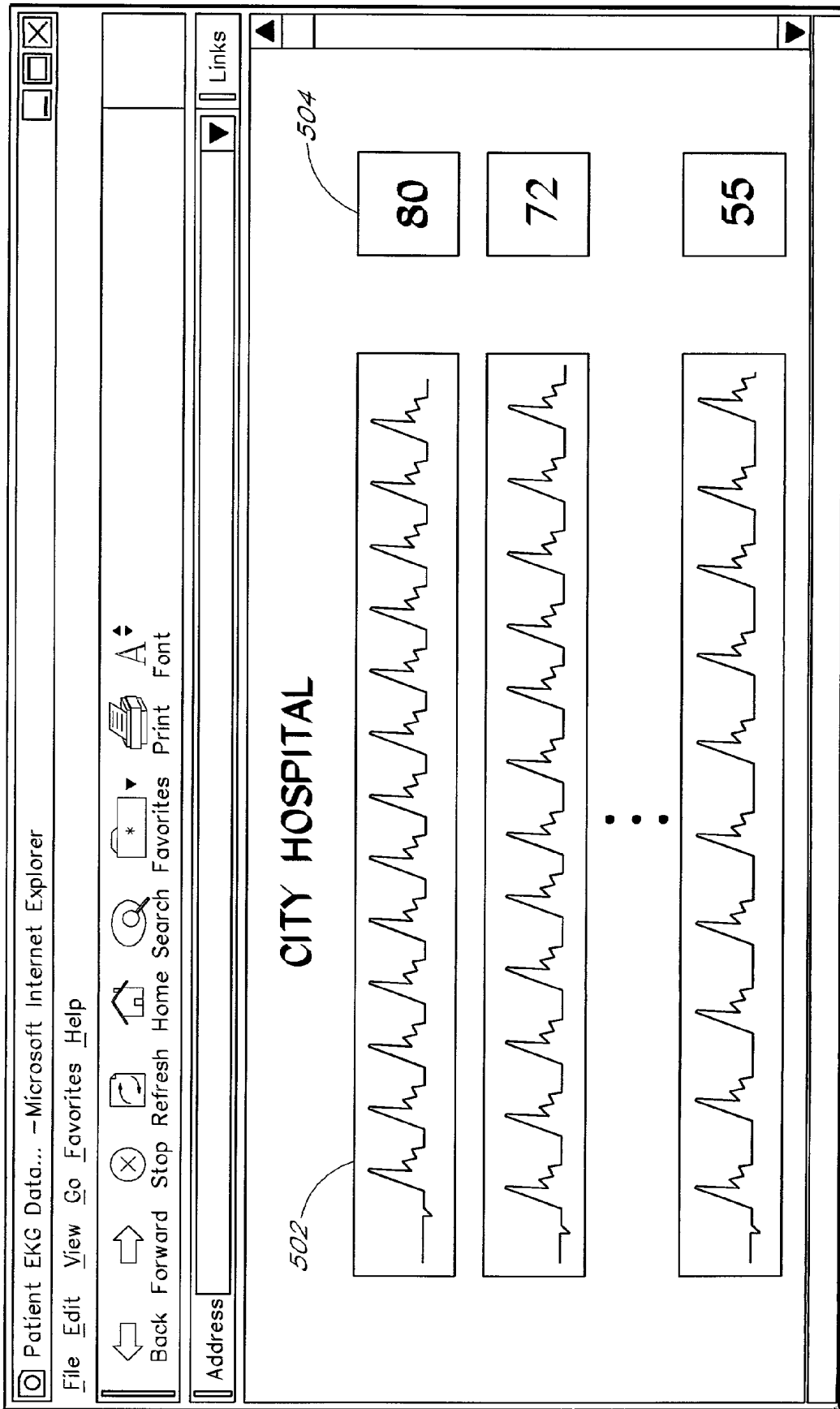

FIG. 5

INTRANET-BASED MEDICAL DATA DISTRIBUTION SYSTEM

REFERENCE TO RELATED APPLICATION

[0001] The present application claims priority from U.S. Provisional Application No. 60/192,510, filed Mar. 28, 2000, titled "INTRANET-BASED MEDICAL DISTRIBUTION SYSTEM," the entire contents of which is hereby incorporated by reference.

BACKGROUND OF THE INVENTION

[0002] 1. Field of the Invention

[0003] The present invention relates to methods for real-time or near real-time distribution of medical telemetry data over a computer network. More particularly, the present invention relates to a network architecture for facilitating the efficient and reliable exchange of information between portable wireless patient monitoring devices and computers located throughout a hospital.

[0004] 2. Description of the Related Art

[0005] Medical telemetry systems that allow physiologic data from multiple, remotely-located patients to be monitored from a central location are known in the art. These systems typically comprise remote telemeters that remotely collect the physiologic data of respective patients and transmit the data over a wireless link to a monitoring station. This physiologic data may include, for example, real-time electrocardiograph (EKG) waveforms, CO₂ levels, blood pressure, temperature, SO₂ levels, respiration rates, etc. From the monitoring station, a clinician can, in real-time, visually monitor the physiologic status of many different patients. The central station may also run automated monitoring software for alerting the clinician whenever a predetermined physiologic event occurs, such as a cardiac arrhythmia condition.

[0006] The remote telemeters of medical telemetry systems are generally of two types: instrument remote telemeters and ambulatory remote telemeters. An ambulatory remote telemeter is a portable, battery-powered device which permits the patient to be monitored while the patient is ambulatory. The ambulatory telemeter attaches to the patient by a strap or other attachment device, and receives the patient's physiologic data via EKG leads (and/or other types of sensor leads) which attach to the patient's body. The physiologic data is continuously transmitted to the central monitoring station by the telemeter's radio frequency (RF) transmitter to permit real-time monitoring. Instrument remote telemeters operate in a similar manner, but receive the patient's physiologic data from a bedside monitor (or other instrument) over a hardwired line, such as an RS-232 connection. Instrument remote telemeters that transfer the physiologic data to the monitoring station over a hardwired connection are also found.

[0007] Typically, the monitoring station includes a receiver for receiving and decoding the RF transmissions from the patient transmitter, and a computer for displaying the physiologic data. In many cases, the receivers are implemented as circuit boards that plug into a standard personal computer. The resulting physiologic data is displayed on the computer screen. In these applications, the process of collecting data and updating the display is rela-

tively simple because the receiver, computer, and display are combined in a single system. Unfortunately, this type of non-networked system does not make the patient telemetry data available throughout the hospital.

[0008] For example, a monitoring station is usually placed at a nurse's station near the patient's room. If a physician, whose office is located in a different wing of the hospital, needs to view the patient's EKG, then the physician must visit the nurse's station where the data is being displayed. Another problem with non-networked monitoring is that inadequacies in the non-networked system architecture make it impractical to monitor a large number of patients (e.g., 500 to 800 or more).

[0009] Prior attempts to use computer networks to facilitate the display of physiologic telemetry data have been cumbersome and expensive because of the real-time nature of the data and the volume of data involved. In such systems, the central station consists of a receiver connected to a computer, which operates as a proprietary network data server. The data is transmitted over a dedicated network, using proprietary hardware and software, to various workstation computers (workstations) located elsewhere in the hospital. This type of system has the advantage of providing access to patient data, but at the expense of installing a custom computer network that is dedicated solely to telemetry data. Again, use of a dedicated network was necessary because of the real-time nature of the data, the volume of data, and the critical nature of the data. Even in situations, such as private networks (Intranets), where the delays introduced by other network traffic can be controlled, the overhead associated with standard protocols, such as HTTP, is often prohibitive.

[0010] It is well known to those skilled in the art of computer operating systems and networks, that the methods for handling real-time data are markedly different from those used to handle non-real-time data. Most computer operating systems are not designed to handle real-time data well. Computer operating systems that are designed to handle real-time data are generally special purpose operating systems not intended for general use. The data from most telemetry systems, including medical telemetry systems, occurs in a continuous stream, and typically must be received continuously. The operating system cannot command the sending device to stop sending the data for any appreciable length of time owing to the time critical nature of the data. For example, in a medical telemetry system that monitors patient EKG waveforms, the clinician must be notified immediately of any emergency conditions. Thus any computer, or computer network, designed to handle medical telemetry data must be capable of processing the data without undue delay. True real-time processing may not be necessary, but the processing must be close to real-time (near-real time or quasi-real time).

[0011] Standard computer networks, meaning networks that employ readily available hardware and software components (e.g., the Internet), are also typically not designed to deliver data in real-time. Standard networks, such as the Internet, are designed to deliver data as quickly as possible, but not on any set schedule. For instance, it is well known to one skilled in the art that a user downloading a large file over the Internet will typically see the data arrive in bursts separated by varying time delays. The amount of time

required for a message to travel from a sending computer to a receiving computer is known as latency time. In a packet-switching network (PSN) such as the Internet, data is usually read and forwarded by several routers before it reaches its destination. No effort is made to establish a single electrical circuit between two computing devices. Instead, the sending computer divides a message into a number of efficiently sized units called packets. Each packet contains the address of the destination computer. These packets are then broadcast to the network. The packets are received by devices called routers that read each packet's destination address and, based on that address, forward the packets in the appropriate direction. Eventually, the packets arrive at their intended destination, although some may have actually traveled by different physical paths. The receiving computer assembles the packets, puts them in order, and delivers the received message to the appropriate application. Packet-switching networks are highly reliable and efficient, but they are not generally suited to the delivery of real-time data because the routing process results in variable latency times (known as jitter).

SUMMARY OF THE INVENTION

[0012] The present invention solves these and other problems by providing an architecture for near real-time distribution of data using standard network hardware and software components. The use of standard "off the shelf" hardware and software components provides a convenient way to leverage existing technology, resulting in lower cost and quicker design. The use of hardware and software developed for a packet switched network such as the Internet is particularly desirable. The use of software developed for the World-Wide Web (WWW) such as standard Web servers and Web browsers (e.g., Netscape, or Microsoft's Internet Explorer) is also particularly desirable.

[0013] The use of standard hardware and software components also allows the telemetry system to be easily customized by the hospital. Thus, even though the patient data may (in one embodiment) never leave the hospital, it is desirable to construct a hospital internal computer network using the same hardware and software components used to construct the global Internet.

[0014] One embodiment includes a patient monitoring system for providing patient data to one or more workstations connected to a computer network from one or more sensors attached to a patient. The sensors are configured to measure physiologic data from the patient. The sensors provide data to a patient monitoring device that is configured to gather the physiologic data and use a communication system to communicate the physiologic data to a central data-monitoring device. One or more waveform servers are connected to the central data-monitoring device and to a computer network. One or more data servers are also connected to the computer network. The data servers are configured to supply data to the workstations using a first protocol. The waveform servers receive the physiologic information from the central data-monitoring device and supply the physiologic data to one or more workstations using a second protocol. In one embodiment, the communication system includes a wireless link between the patient monitoring device and the central data-monitoring device. In one embodiment, the first protocol is a low level network protocol. In one embodiment, the first protocol is TCP/IP. In

one embodiment, the second protocol is a high level protocol. In one embodiment, the second protocol is an application-level protocol. In one embodiment, the second protocol uses the first protocol.

[0015] In one embodiment of the patient monitoring system, the second software program is configured to obtain said physiologic data from at least one of the waveform servers in data packets with varying latency periods, and the second software program is configured to display the physiologic data on a display device such that it appears to a person observing the display device that the physiologic data is being received as a stream of data with relatively uniform latency periods.

BRIEF DESCRIPTION OF THE FIGURES

[0016] These and other aspects, advantages, and novel features of the invention will become apparent upon reading the following detailed description and upon reference to the accompanying drawings, in which:

[0017] **FIG. 1** is an overview of a network-based patient monitoring system;

[0018] **FIG. 2** is a block diagram of a network-based patient monitoring system;

[0019] **FIG. 3** is a block diagram of the network protocol stacks use to provide communications between the Web server, the waveform server, and the Web browser.

[0020] **FIG. 4** is a messaging diagram of the messages passed between the Web server, waveform server, and workstations (workstations) in a network based patient monitoring system.

[0021] **FIG. 5** is an exemplary screen display of a patient's EKG and heart rate.

DETAILED DESCRIPTION

[0022] In the disclosure that follows, the term "Internet" will be understood to mean any computer network constructed using Internet compatible components. The disclosure describes the present invention in terms of the Internet only because the preferred embodiment uses Internet compatible components, and because the workings of such standard components are widely understood by those skilled in the art. One skilled in the art will appreciate that the present invention is not limited to the Internet, or Internet-compatible components. One skilled in the art will further appreciate that, even though the present invention is particularly advantageous for packet switched networks such as the Internet (or an intranet), the present invention provides benefits to any computer network.

[0023] **FIG. 1** is an overview of a network-based patient monitoring system **100**. The system **100** comprises a patient **101**. A series of sensors **103** (e.g., EKG leads) are attached to the patient **101** to measure various types of physiologic data. The leads **103** are also attached to a medical telemetry device **102**. The medical telemetry device **102** transmits the physiological data from the patient **101**, to a central station **104**. The central station **104** is attached to a network **105**. Also attached to the network **105** are a series of workstation computers (workstations) **106**. The workstations **106** are typically located at nursing stations throughout the hospital. Nurses and clinicians **107** use the workstations **106** to view

the physiologic data collected from the patient **101** and to view hospital patient records.

[0024] The workstation **106** typically runs a standard operating system (e.g., Microsoft Windows) and a standard Web browser (e.g., Microsoft's Internet Explorer). In one embodiment, the hospital creates a Web page for each patient and stores the Web page in the hospital database **230** (shown in FIG. 2). The nurse **107** can conveniently view information about the patient **101** contained in the database by using the workstation **106** to open the Web page corresponding the patient **101**. If the patient **101** is attached to a telemetry device **102**, and the waveform server **104** is receiving physiologic data from the telemetry device **102**, then the nurse **107** can view the telemetry data (such as an EKG) using a media player applet loaded by the Web page.

[0025] FIG. 2 is a system block diagram of the network-based patient monitoring system **100** wherein the system **100** is described in terms of three major components: a patient component **215**, a server component **216**, and a client component **217**. The patient component **215** comprises one or more patient transmitters **102**, each patient transmitter having an antenna **202** for transmitting data to the central station **104**. The central server **104** comprises one or more Web servers **205**, one or more waveform servers **204** and one or more receivers **211**. In input of each receiver **211** is connected to an antenna, and an output of each receiver **211** is connected to at least one of the waveform servers **204**. The waveform servers **204** and Web the servers **205** are connected to the network **105**. The Web servers **205** are also connected to a hospital database **230**. The hospital database **230** contains patient records.

[0026] The network client component **217** comprises a series of workstations **106** connected to the network **105**. Each workstation **106** runs a World Wide Web (WWW or Web) browser application **208**. Each Web browser can open a page that includes one or more media player applets **210**. The waveform servers **204** use the network **105** to send a series of messages **220** to the Web servers **205**. The Web servers **205** use the network **105** to communicate messages, shown as a path **221**, to the workstations **106**. The media player applets running on the workstations **106** use the network **105** to send messages over a path **223** directly to the waveform servers **204**.

[0027] The details of the interprocess communication between the Web servers **205**, the waveform servers **204** and the browser application **208** is best understood by examining the layers of software and hardware, know as protocol stacks, shown in FIG. 3. FIG. 3 is a block diagram of the network protocol stacks used to provide communications between the Web servers **205**, the waveform servers **204**, and the Web browser **208**. A waveform stack **301** shows the network protocol stack running on the waveform servers **204**, a Web stack **302** shows the network protocol stack running on the Web server **302**, and a browser stack **303** shows the network protocol stack running on the workstation **106**. Each protocol stack comprises, from top to bottom, an application layer **305**, a transport layer **307**, a network layer **308**, and a physical layer **309**.

[0028] The physical layer **309** on the waveform stack **301** is a network hardware interface **316**. The network layer **308** on the waveform stack **301** is an Internet Protocol (IP) layer **314**. The transport layer **307** on the waveform stack **301** is

a Transmission Control Protocol (TCP) layer **312**. The TCP layer **312** provides a socket interface **311** to a waveform server program **310**. The waveform server program **310** runs in the application layer **305** on the waveform stack **301**.

[0029] The physical layer **309** on the Web stack **302** is a network hardware interface **328**. The network layer **308** on the Web stack **302** is an IP layer **326**. The transport layer **307** on the Web stack **302** is a TCP layer **324**. The application layer **305** on the Web stack **302** is a Web server program **320** overlaying an HTTP layer **322**.

[0030] The physical layer **309** on the browser stack **303** is a network hardware interface **342**. The network layer **308** on the browser stack **303** is an IP layer **340**. The transport layer **307** on the browser stack **303** is a TCP layer **338**. The TCP layer **338** provides a socket interface **336** to a Web browser program **330**. The Web browser program **330** runs in the application layer **305** on the browser stack **303**. The Web browser program advantageously provides an HTTP interface **334** and an applet **210**. A socket connection **350** connects the socket **311** to the socket **336**. The Web server software **320** is connected to the Web browser software **330** by an HTTP connection **352**. One skilled in the art will know that any particular layer typically communicates primarily with the layers immediately above or below that layer. The network **105** provides communication between the different stacks. A message sent by the application layer **320** to the application layer **330** propagates through the layers (in order) **322**, **324**, **326**, **328**, **342**, **340**, **338**, and **330**, as shown by the connection **352**. This conceptual model applies even when two applications are running on the same computer (the conceptual model still applies, even though some systems recognize that in such circumstances, the lower layers can be bypassed in order to gain efficiency).

[0031] The TCP layers **312**, **324**, and **338**, and the IP layers **314**, **326**, and **340**, (more commonly known as TCP/IP) work together to provide the necessary data transmission and error correction functions needed to transfer of data from one network linked computer to another network linked computer.

[0032] The IP portion of TCP/IP is a connectionless protocol that describes how an Internet connected computer should break data down into packets for transmission across the network, and how those packets should be addressed so that they arrive at their destination. A connectionless protocol is a protocol that enables the transmission of data from one computer to another, even though no effort is made to determine whether the receiving computer is on-line or able to receive the information. All packet switching networks use some form of connectionless protocol. IP is the lowest level of the TCP/IP structure and it is concerned only with breaking data down into packets for transmission, and reassembling the packets after they have been received.

[0033] TCP is a connection-oriented protocol that establishes a procedure by which two computers on the network can establish a connection that lasts until the two computers have successfully exchanged data. This is accomplished by means of handshaking in which the two computers exchange messages. Handshaking is similar to registered mail. In a handshaking transaction: the first computer sends a "ready" message indicating that it is ready to accept data; when the second computer receives the ready message, it responds by sending data to the first computer; finally, when the first

computer receives the data, it sends a "data received" message back to the second computer. The handshaking ensures that the data was sent and properly received. When an error does occur, both computers will be aware of the error and arrange to re-send the data.

[0034] Software programs running in the application layer **305** generally access the services of TCP through the use of a general purpose interprocess communication (IPC) mechanism known as a socket (a socket connection). The socket connection is a logical entity through which a first process (or program) communicates with a second process. Sockets can use any communication protocol, but generally TCP/IP is preferred. The first and second processes may be running on the same computer, or they may be running on separate computers (when the two computers are connected by a network). Each socket is associated with a socket identification (ID) comprising an IP address and a port number. The IP address identifies the network address of the second computer. The port number identifies a particular application running on the second computer (the computer identified by the IP address). Some well-known software applications have standardized port numbers, known as "well known ports." Thus, for example, standard Internet applications such as Telnet, File Transfer Protocol (FTP) and Web browsers all correspond to specific ports.

[0035] Since sockets are generic, different parts of an application program can execute on several different machines simultaneously, and an application can open more than one socket at a time. In the present invention, the waveform server usually runs on a first computer, the Web (HTTP) server runs on a second computer, and the waveform viewer (the applet **210**) runs on a third computer. A process or function associated with a socket is known as a socket client. The socket client is said to "own" the socket; that is, it can make use of the socket to request and receive information and network services. Raw sockets are used for communications by low-level protocols, and are usually available only to privileged program. Stream sockets, are higher-level mechanisms that provide reliable connections that guarantee delivery of the data.

[0036] The Web browser **209** and the web server s communicate using a high-level protocol known as HTTP. HTTP is an application layer protocol for distributed, collaborative, hypermedia information systems. It is a generic, object-oriented protocol which can be used for many tasks, including file transfer, news, electronic mail, etc. HTTP uses the TCP protocol for data transport. However, the effects of HTTP's inefficient use of TCP on the Internet have resulted in major problems caused by congestion and unnecessary overhead.

[0037] Unfortunately, many of the solutions proposed for improving HTTP performance are largely ineffective with regards to real-time telemetry data. For example, caching of telemetry data is ineffective because caching presupposes that the data stored on the server has not changed since the last access. Telemetry data is continuously changing and typically does not benefit from being cached.

[0038] The current trend in the art is to improve the performance of Web pages that use HTTP by making changes to HTTP itself. The present invention uses an entirely different solution not suggested by the current efforts to improve HTTP. The present invention avoids the

inefficiencies of HTTP by using HTTP only for the purposes for which it is suited, such as formatting textual information, downloading slowly changing data (e.g., patient records from the hospital database **230**), and running small applications (e.g., the applet **210**). The present invention uses other standard methods, such as a direct socket connection, to provide rapid, near real-time waveform data to the workstation **106**. In the present invention, a workstation **106**, running a Web browser stack **303**, uses HTTP to open a Web page corresponding to a patient **101**. Messages are passed between the Web browser **330** and the Web server **332** using the relatively inefficient HTTP protocol. The Web browser **303** loads a Web page **209**, which displays relatively static (or quasi-static) fields such as patient name, room, etc. The Web page also displays a window for showing real-time patient physiologic information, such as an EKG. The Web page loads an applet **210** (a small program run from within the Web browser) which begins to run once the Web page **209** is loaded. In one embodiment, the applet **210** is written in the JAVA programming language.

[0039] Once the applet **210** begins to run, the applet **210** opens a socket connection **336**. The socket **336** connects to a socket **311** on the waveform server via a socket connection **350**. Once the socket connection **350** established, the applet **210** is able to send requests, and receive data from, the waveform server **310**.

[0040] FIG. 4 is a time-sequence diagram of the messages passed between the Web servers **205**, the waveform servers **204** and the workstation **106** (the Web browser **330** and the applet **210** both run on the workstation **106**). One skilled in the art will understand that a time-sequence diagram refers to a technique for graphically representing events occurring in a software system. In such a diagram, time is represented on a vertical axis, with the oldest events at the top and the most recent events at the bottom. The information presented horizontally shows messages traveling from one computer to another.

[0041] FIG. 4 shows a column **401** corresponding to operations performed by the waveform servers **204**, a column **402** corresponding to operations performed by the Web servers **205**, and a column **403** corresponding to operations performed by the workstations **106**. In a process block **411**, the waveform servers **204** detect transmissions from a patient transmitter **102**. Upon detecting the transmissions, the waveform servers **204** send a notification message **410** to the Web servers **205** and then transitions to a process block **412**. In the process block **412** the waveform servers **204** collect and buffer data from the patient transmitter **102**. A thread in the waveform servers **204** loops in the process block **412** until the data collection and buffering operation is terminated by some external event (e.g., the patient transmitter **102** is turned off).

[0042] The Web server receives the notification message **410** in a process block **413**. Upon receipt of the notification **410**, the Web server transitions to a process block **414** where it creates a new Web page corresponding to the patient **101**. Upon creation of the new Web page, the Web servers **205** send a notification message **416** to the workstation **106**. The workstation **106** receives the notification message **416** in a process block **417**. In the process block **417**, the workstation **106** notifies the user (e.g., the Nurse) that the new Web page, corresponding to a new patient **102**, is available. The work-

station **106** then transitions to a process block **418** where the user opens the Web page to view the data corresponding to the patient **101**. After opening the Web page in the process block **418**, the workstation **106** transitions to a process block **420** where the workstation runs a media player applet **210** attached to the Web page. The media player applet **210** opens a socket connection **350** to the waveform servers **204** and sends a notification message **424** to the waveform server. The waveform servers **204** receive the notification message **424** in a process block **423** and sends a return notification message **424** to the applet **210**.

[0043] Upon receipt of the return notification message **424**, the applet **210** transitions to a process block **426**. In the process block **426**, the applet sends a data request message **428** to the waveform servers **204**. The waveform servers **204** receive the data request **428** in a process block **431**. Upon receipt of the message **428** in the process block **431**, the waveform servers **204** retrieve data from the data buffer and transitions to a process block **433** to send the data. In the process block **433**, the waveform servers **204** send the patient data to the workstation **106** using a message **432**. The workstation **106** receives the data message **432** in a process block **434**. Upon receipt of the data in the process block **434**, the workstation **106** advances to a process block **436** where it stores the data in a buffer. The workstation **106** then advances to a process block **438** where it retrieves data from the buffer and updates a display showing patient data. After updating the display, the workstation **106** jumps back to the process block **426** to retrieve more data. The workstation **106** continues the loop of requesting data in the process block **426**, receiving data in the process block **434**, buffering the data in the process block **436**, and displaying the data in the process block **438** until either the patient transmitter goes offline (in which case there is no more data to display), or the nurse or user of the workstation **106** closes the applet **210**.

[0044] The socket connection **350** provides a fast, low overhead, method for the media player applet **210** to retrieve the EKG data from the waveform server. In a preferred embodiment, the media player **210** reads 80 samples/second in a single 80 byte transfer (8 bit samples) once per second. The media player **210** buffers 4 to 5 seconds of data in a circular ring buffer.

[0045] FIG. 5 is an exemplary screen display of a patient EKG and heart rate. FIG. 5 shows the Web page **208** having a series of displays as exemplified by the EKG display **502** showing a plot of EKG data in a number display **504** showing patient heart rate corresponding to the EKG **502**. One skilled in the art will recognize that EKG data can be shown either by a scrolling waveform that moves along the screen display, or by a moving bar where the waveform is essentially stationary and the bar moves across the screen.

[0046] Other Embodiments

[0047] While the present invention has been particularly shown and described with reference to preferred embodiments thereof, it will be understood by those skilled in the art that various changes in form and detail may be made therein without departing from the spirit, scope and teaching of the invention. Accordingly, the embodiments herein disclosed are to be considered merely as illustrative and limited in scope only as specified in the appended claims.

What is claimed is:

1. A patient monitoring system for providing patient data to one or more workstations connected to a computer network, said system comprising:

one or more sensors attached to said patient, said sensors configured to measure physiologic data from said patient;

a patient monitoring device attached to said one or more sensors, said patient monitoring device configured to gather said physiologic data and use a communication system to communicate said physiologic data to a central data monitoring device;

one or more data servers connected to said computer network, said data servers configured to supply data to said workstations using a first protocol; and

one or more waveform servers connected to said central data monitoring device, said waveform servers receiving said physiologic information from said central data monitoring device, said waveform servers connected to said computer network, said waveform servers configured to supply said physiologic data to said workstations using a second protocol.

2. The patient monitoring system of claim 1, wherein said communication system comprises a wireless link between said patient monitoring device and said central data monitoring device.

3. The patient monitoring system of claim 1, wherein said first protocol is a low level network protocol.

4. The patient monitoring system of claim 3, wherein said first protocol is TCP/IP.

5. The patient monitoring system of claim 1, wherein said second protocol is a high level protocol.

6. The patient monitoring system of claim 5, wherein said high level protocol is an application level protocol.

7. The patient monitoring system of claim 3, wherein said second protocol is a high level protocol.

8. The patient monitoring system of claim 7, wherein said second protocol uses said first protocol.

9. The patient monitoring system of claim 8, wherein said first protocol is TCP/IP and said second protocol is HTTP.

10. The patient monitoring system of claim 1, further comprising a first software program stored within a memory in said workstations, said software configured to communicate with said data server using said first protocol.

11. The patient monitoring system of claim 10, wherein said first software program is configured to run a second software program substantially contemporaneously with said first software program.

12. The patient monitoring system of claim 11, wherein said second software program is configured to communicate with at least one of said waveform servers using said first protocol.

13. The patient monitoring system of claim 11, wherein said second software program is configured to obtain said physiologic data from at least one of said waveform servers by communicating with said at least one of said waveform servers using said first protocol.

14. The patient monitoring system of claim 13, wherein said second software program is configured to obtain said physiologic data from said at least one of said waveform servers in data packets with varying latency periods, and wherein said second software program is configured to

display said physiologic data on a display device such that it appears to a person observing said display device that physiologic data is being received as a stream of data with uniform latency periods.

15. A method for efficiently using a packet switched computer network to provide quasi-static data and near real-time data to a workstation, where said quasi-static data is related to said near real-time data, said method comprising the steps of:

using a first server software module to supply said quasi-static data, over said network, to said workstation, using a first protocol;

using a second server software module to supply said near real-time data, over said network, to said workstation, using a second protocol;

using a first client software module running on said workstation to receive said quasi-static data, from said network; and

using a second client software module running on said workstation to receive said near real-time data from said network.

16. The method of claim 15, further comprising the steps of:

gathering said near real-time data at a location remote from said second data server; and

using a communication device to communicate said near-real time data from said remote location to said second data server.

17. The method of claim 15, wherein said first protocol is HTTP.

18. The method of claim 15, wherein said second protocol is TCP/IP.

19. The method of claim 15, wherein said first server is a Web server.

20. The method of claim 19, wherein said first client is a Web browser.

21. The method of claim 20, wherein said second client software module is an applet loaded by said Web browser.

22. The method of claim 21, wherein said applet is written in the JAVA programming language.

23. The method of claim 20, further comprising the step of displaying said quasi-static data and said near real-time data on a display device.

24. The method of claim 15, wherein said second client software module uses a socket connection to retrieve said near real-time data from said second server.

25. A method for efficiently using a packet switched computer network to provide database data and physiologic data to a workstation, where said database data is related to said physiologic data, said method comprising the steps of:

using a first server software program to supply said database data, over said network, to said workstation, using a first protocol;

using a second server software program to supply said physiologic data, over said network, to said workstation, using a second protocol;

using a first client software program running on said workstation to receive said database data, from said network; and

using a second client software program running on said workstation to receive said physiologic data from said network.

* * * * *

专利名称(译)	基于Intranet的医疗数据分发系统		
公开(公告)号	US20010044823A1	公开(公告)日	2001-11-22
申请号	US09/818072	申请日	2001-03-27
[标]申请(专利权)人(译)	LABOUNTY SCOTT CLARK戴维r JOHNNIE DARRYN一个		
申请(专利权)人(译)	LABOUNTY SCOTT CLARK DAVID R. JOHNNIE DARRYN A.		
当前申请(专利权)人(译)	LABOUNTY SCOTT CLARK DAVID R. JOHNNIE DARRYN A.		
[标]发明人	LABOUNTY SCOTT CLARK DAVID R JOHNNIE DARRYN A		
发明人	LABOUNTY, SCOTT CLARK, DAVID R. JOHNNIE, DARRYN A.		
IPC分类号	A61B5/00 A61B5/0205 A61B5/021 A61B5/0402 A61B5/044 A61B5/0464 G06F19/00 H04L12/56 G06F15/16		
CPC分类号	A61B5/0006 A61B5/0205 A61B5/021 A61B5/0402 A61B5/044 A61B5/0464 G06F19/322 G06F19/327 G06F19/3418 H04W4/18 H04W88/14 G16H10/60 G16H40/20 G16H40/67		
优先权	60/192510 2000-03-28 US		
其他公开文献	US6871211		
外部链接	Espacenet USPTO		

摘要(译)

基于网络的医疗遥测系统，尽可能使用标准硬件和软件组件。该系统允许临床医生在大医院的任何地方使用计算机查看医院患者的生理数据。每位患者都配有一组测量患者生理特性的传感器（例如，EKG传感器）。传感器连接到发射器，该发射器将生理数据中继到中央服务器。中央服务器包括WEB服务器，其提供基本患者数据，例如患者姓名和病史。中央服务器还包括波形服务器，其实时或接近实时地提供生理数据。临床医生使用的工作站接收来自Web服务器的基本患者数据和来自波形服务器的生理数据，并产生组合显示。组合显示器不断更新，显示例如患者的EKG。

