



US009724024B2

(12) **United States Patent**  
**Al-Ali**

(10) **Patent No.:** **US 9,724,024 B2**  
(45) **Date of Patent:** **Aug. 8, 2017**

(54) **ADAPTIVE ALARM SYSTEM**

(56) **References Cited**

(75) Inventor: **Ammar Al-Ali**, San Juan Capistrano, CA (US)

U.S. PATENT DOCUMENTS

4,960,128 A 10/1990 Gordon et al.  
4,964,408 A 10/1990 Hink et al.

(73) Assignee: **Masimo Corporation**, Irvine, CA (US)

(Continued)

(\* ) Notice: Subject to any disclaimer, the term of this patent is extended or adjusted under 35 U.S.C. 154(b) by 572 days.

FOREIGN PATENT DOCUMENTS

WO WO 03/007815 1/2003  
WO WO 03/028549 4/2003  
WO WO 2009/093159 7/2009

(21) Appl. No.: **13/037,184**

OTHER PUBLICATIONS

(22) Filed: **Feb. 28, 2011**

US 8,845,543, 09/2014, Diab et al. (withdrawn)  
(Continued)

(65) **Prior Publication Data**

US 2011/0213212 A1 Sep. 1, 2011

*Primary Examiner* — Eric Winakur

*Assistant Examiner* — Chu Chuan (JJ) Liu

(74) *Attorney, Agent, or Firm* — Knobbe Martens Olson & Bear, LLP

**Related U.S. Application Data**

(57) **ABSTRACT**

(60) Provisional application No. 61/309,419, filed on Mar. 1, 2010, provisional application No. 61/328,630, filed on Apr. 27, 2010.

An adaptive alarm system is responsive to a physiological parameter so as to generate an alarm threshold that adapts to baseline drift in the parameter and reduce false alarms without a corresponding increase in missed true alarms. The adaptive alarm system has a parameter derived from a physiological measurement system using a sensor in communication with a living being. A baseline processor calculates a parameter baseline from a parameter trend. Parameter limits specify an allowable range of the parameter. An adaptive threshold processor calculates an adaptive threshold from the parameter baseline and the parameter limits. An alarm generator is responsive to the parameter and the adaptive threshold so as to trigger an alarm indicative of the parameter crossing the adaptive threshold. The adaptive threshold is responsive to the parameter baseline so as to increase in value as the parameter baseline drifts to a higher parameter value and to decrease in value as the parameter baseline drifts to a lower parameter value.

(51) **Int. Cl.**

**A61B 5/1455** (2006.01)  
**A61B 5/00** (2006.01)  
**G08B 29/26** (2006.01)

(52) **U.S. Cl.**

CPC ..... **A61B 5/14551** (2013.01); **A61B 5/746** (2013.01); **G08B 29/26** (2013.01); **A61B 2560/0276** (2013.01)

(58) **Field of Classification Search**

CPC . A61B 5/1455; A61B 5/14551; A61B 5/0002; A61B 5/14532; A61B 5/0059; A61B 5/14552; A61B 5/14553

(Continued)

**11 Claims, 14 Drawing Sheets**

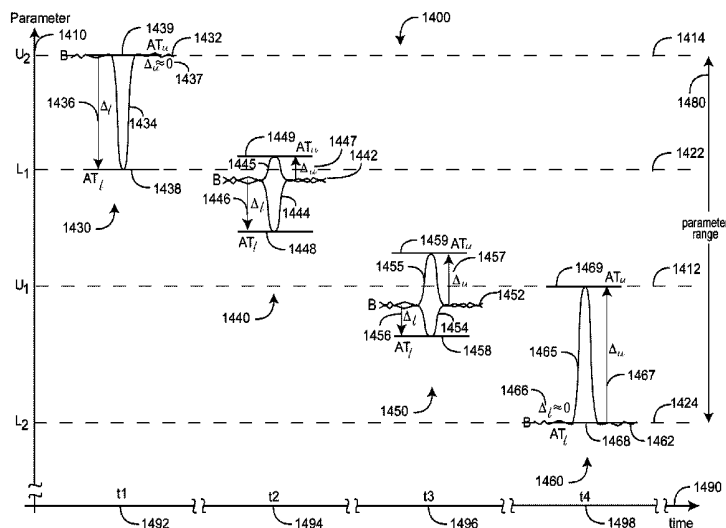

(58) **Field of Classification Search**  
 USPC ..... 600/300, 301, 310, 322, 323, 324, 473,  
 600/476, 500, 508; 356/41; 340/573.1  
 See application file for complete search history.

(56) **References Cited**

U.S. PATENT DOCUMENTS

5,041,187 A 8/1991 Hink et al.  
 5,069,213 A 12/1991 Polczynski  
 5,163,438 A 11/1992 Gordon et al.  
 5,285,782 A \* 2/1994 Prosser ..... 600/324  
 5,319,355 A 6/1994 Russek  
 5,337,744 A 8/1994 Branigan  
 5,341,805 A 8/1994 Stavridi et al.  
 D353,195 S 12/1994 Savage et al.  
 D353,196 S 12/1994 Savage et al.  
 5,377,676 A 1/1995 Vari et al.  
 D359,546 S 6/1995 Savage et al.  
 5,431,170 A 7/1995 Mathews  
 D361,840 S 8/1995 Savage et al.  
 D362,063 S 9/1995 Savage et al.  
 5,452,717 A 9/1995 Branigan et al.  
 D363,120 S 10/1995 Savage et al.  
 5,456,252 A 10/1995 Vari et al.  
 5,464,012 A \* 11/1995 Falcone ..... 600/301  
 5,479,934 A 1/1996 Imran  
 5,482,036 A 1/1996 Diab et al.  
 5,490,505 A 2/1996 Diab et al.  
 5,494,043 A 2/1996 O'Sullivan et al.  
 5,533,511 A 7/1996 Kaspari et al.  
 5,534,851 A 7/1996 Russek  
 5,561,275 A 10/1996 Savage et al.  
 5,562,002 A 10/1996 Lalin  
 5,590,649 A 1/1997 Caro et al.  
 5,602,924 A 2/1997 Durand et al.  
 5,632,272 A 5/1997 Diab et al.  
 5,638,816 A 6/1997 Kiani-Azarbayjany et al.  
 5,638,818 A 6/1997 Diab et al.  
 5,645,440 A 7/1997 Tobler et al.  
 5,685,299 A 11/1997 Diab et al.  
 D393,830 S 4/1998 Tobler et al.  
 5,743,262 A 4/1998 Lepper, Jr. et al.  
 5,758,644 A 6/1998 Diab et al.  
 5,760,910 A 6/1998 Lepper, Jr. et al.  
 5,769,785 A 6/1998 Diab et al.  
 5,782,757 A 7/1998 Diab et al.  
 5,785,659 A 7/1998 Caro et al.  
 5,791,347 A 8/1998 Flaherty et al.  
 5,810,734 A 9/1998 Caro et al.  
 5,823,950 A 10/1998 Diab et al.  
 5,830,131 A 11/1998 Caro et al.  
 5,833,618 A 11/1998 Caro et al.  
 5,860,919 A 1/1999 Kiani-Azarbayjany et al.  
 5,890,929 A 4/1999 Mills et al.  
 5,904,654 A 5/1999 Wohltmann et al.  
 5,919,134 A 7/1999 Diab  
 5,934,925 A 8/1999 Tobler et al.  
 5,940,182 A 8/1999 Lepper, Jr. et al.  
 5,995,855 A 11/1999 Kiani et al.  
 5,997,343 A 12/1999 Mills et al.  
 6,002,952 A 12/1999 Diab et al.  
 6,011,986 A 1/2000 Diab et al.  
 6,027,452 A 2/2000 Flaherty et al.  
 6,036,642 A 3/2000 Diab et al.  
 6,045,509 A 4/2000 Caro et al.  
 6,067,462 A 5/2000 Diab et al.  
 6,081,735 A 6/2000 Diab et al.  
 6,088,607 A 7/2000 Diab et al.  
 6,110,522 A 8/2000 Lepper, Jr. et al.  
 6,124,597 A 9/2000 Shehada  
 6,128,521 A 10/2000 Marro et al.  
 6,129,675 A 10/2000 Jay  
 6,144,868 A 11/2000 Parker  
 6,151,516 A 11/2000 Kiani-Azarbayjany et al.  
 6,152,754 A 11/2000 Gerhardt et al.  
 6,157,850 A 12/2000 Diab et al.

6,165,005 A 12/2000 Mills et al.  
 6,184,521 B1 2/2001 Coffin, IV et al.  
 6,206,830 B1 3/2001 Diab et al.  
 6,229,856 B1 5/2001 Diab et al.  
 6,232,609 B1 5/2001 Snyder et al.  
 6,236,872 B1 5/2001 Diab et al.  
 6,241,661 B1 \* 6/2001 Schluess et al. .... 600/300  
 6,241,683 B1 6/2001 Macklem et al.  
 6,253,097 B1 6/2001 Aronow et al.  
 6,256,523 B1 7/2001 Diab et al.  
 6,263,222 B1 7/2001 Diab et al.  
 6,278,522 B1 8/2001 Lepper, Jr. et al.  
 6,280,213 B1 8/2001 Tobler et al.  
 6,285,896 B1 9/2001 Tobler et al.  
 6,301,493 B1 10/2001 Marro et al.  
 6,317,627 B1 11/2001 Ennen et al.  
 6,321,100 B1 11/2001 Parker  
 6,325,761 B1 12/2001 Jay  
 6,334,065 B1 12/2001 Al-Ali et al.  
 6,343,224 B1 1/2002 Parker  
 6,349,228 B1 2/2002 Kiani et al.  
 6,360,114 B1 3/2002 Diab et al.  
 6,368,283 B1 4/2002 Xu et al.  
 6,371,921 B1 4/2002 Caro et al.  
 6,377,829 B1 4/2002 Al-Ali  
 6,388,240 B2 5/2002 Schulz et al.  
 6,397,091 B2 5/2002 Diab et al.  
 6,430,437 B1 8/2002 Marro  
 6,430,525 B1 8/2002 Weber et al.  
 6,463,311 B1 10/2002 Diab  
 6,470,199 B1 10/2002 Kopotic et al.  
 6,501,975 B2 12/2002 Diab et al.  
 6,505,059 B1 1/2003 Kollias et al.  
 6,515,273 B2 2/2003 Al-Ali  
 6,519,487 B1 2/2003 Parker  
 6,525,386 B1 2/2003 Mills et al.  
 6,526,300 B1 2/2003 Kiani et al.  
 6,541,756 B2 4/2003 Schulz et al.  
 6,542,764 B1 4/2003 Al-Ali et al.  
 6,580,086 B1 6/2003 Schulz et al.  
 6,584,336 B1 6/2003 Ali et al.  
 6,595,316 B2 7/2003 Cybulski et al.  
 6,597,932 B2 7/2003 Tian et al.  
 6,597,933 B2 7/2003 Kiani et al.  
 6,606,511 B1 8/2003 Ali et al.  
 6,632,181 B2 10/2003 Flaherty et al.  
 6,639,668 B1 10/2003 Trepagnier  
 6,640,116 B2 10/2003 Diab  
 6,643,530 B2 11/2003 Diab et al.  
 6,650,917 B2 11/2003 Diab et al.  
 6,654,624 B2 11/2003 Diab et al.  
 6,658,276 B2 12/2003 Kianl et al.  
 6,661,161 B1 12/2003 Lanzo et al.  
 6,671,531 B2 12/2003 Al-Ali et al.  
 6,678,543 B2 1/2004 Diab et al.  
 6,684,090 B2 1/2004 Ali et al.  
 6,684,091 B2 1/2004 Parker  
 6,697,656 B1 2/2004 Al-Ali  
 6,697,657 B1 2/2004 Shehada et al.  
 6,697,658 B2 2/2004 Al-Ali  
 RE38,476 E 3/2004 Diab et al.  
 6,699,194 B1 3/2004 Diab et al.  
 6,714,804 B2 3/2004 Al-Ali et al.  
 RE38,492 E 4/2004 Diab et al.  
 6,721,582 B2 4/2004 Trepagnier et al.  
 6,721,585 B1 4/2004 Parker  
 6,725,075 B2 4/2004 Al-Ali  
 6,728,560 B2 4/2004 Kollias et al.  
 6,735,459 B2 5/2004 Parker  
 6,745,060 B2 6/2004 Diab et al.  
 6,754,516 B2 \* 6/2004 Mannheimer ..... 600/323  
 6,760,607 B2 7/2004 Al-Ali  
 6,770,028 B1 8/2004 Ali et al.  
 6,771,994 B2 8/2004 Kiani et al.  
 6,792,300 B1 9/2004 Diab et al.  
 6,813,511 B2 11/2004 Diab et al.  
 6,816,741 B2 11/2004 Diab  
 6,822,564 B2 11/2004 Al-Ali  
 6,826,419 B2 11/2004 Diab et al.

(56)

## References Cited

## U.S. PATENT DOCUMENTS

6,830,711	B2	12/2004	Mills et al.	7,467,002	B2	12/2008	Weber et al.
6,850,787	B2	2/2005	Weber et al.	7,469,157	B2	12/2008	Diab et al.
6,850,788	B2	2/2005	Al-Ali	7,471,969	B2	12/2008	Diab et al.
6,852,083	B2	2/2005	Caro et al.	7,471,971	B2	12/2008	Diab et al.
6,861,639	B2	3/2005	Al-Ali	7,483,729	B2	1/2009	Al-Ali et al.
6,898,452	B2	5/2005	Al-Ali et al.	7,483,730	B2	1/2009	Diab et al.
6,920,345	B2	7/2005	Al-Ali et al.	7,489,958	B2	2/2009	Diab et al.
6,931,268	B1	8/2005	Kiani-Azarbayjany et al.	7,496,391	B2	2/2009	Diab et al.
6,934,570	B2	8/2005	Kiani et al.	7,496,393	B2	2/2009	Diab et al.
6,939,305	B2	9/2005	Flaherty et al.	D587,657	S	3/2009	Al-Ali et al.
6,943,348	B1	9/2005	Coffin, IV	7,499,741	B2	3/2009	Diab et al.
6,950,687	B2	9/2005	Al-Ali	7,499,835	B2	3/2009	Weber et al.
6,961,598	B2	11/2005	Diab	7,500,950	B2	3/2009	Al-Ali et al.
6,970,792	B1	11/2005	Diab	7,509,154	B2	3/2009	Diab et al.
6,979,812	B2	12/2005	Al-Ali	7,509,494	B2	3/2009	Al-Ali
6,985,764	B2	1/2006	Mason et al.	7,510,849	B2	3/2009	Schurman et al.
6,993,371	B2	1/2006	Kiani et al.	7,526,328	B2	4/2009	Diab et al.
6,996,427	B2	2/2006	Ali et al.	7,530,942	B1	5/2009	Diab
6,999,904	B2	2/2006	Weber et al.	7,530,949	B2	5/2009	Al Ali et al.
7,003,338	B2	2/2006	Weber et al.	7,530,955	B2	5/2009	Diab et al.
7,003,339	B2	2/2006	Diab et al.	7,563,110	B2	7/2009	Al-Ali et al.
7,015,451	B2	3/2006	Dalke et al.	7,596,398	B2	9/2009	Al-Ali et al.
7,024,233	B2	4/2006	Ali et al.	7,618,375	B2	11/2009	Flaherty
7,027,849	B2	4/2006	Al-Ali	D606,659	S	12/2009	Kiani et al.
7,030,749	B2	4/2006	Al-Ali	7,647,083	B2	1/2010	Al-Ali et al.
7,039,449	B2	5/2006	Al-Ali	D609,193	S	2/2010	Al-Ali et al.
7,041,060	B2	5/2006	Flaherty et al.	D614,305	S	4/2010	Al-Ali et al.
7,044,918	B2	5/2006	Diab	RE41,317	E	5/2010	Parker
7,067,893	B2	6/2006	Mills et al.	7,729,733	B2	6/2010	Al-Ali et al.
7,096,052	B2	8/2006	Mason et al.	7,734,320	B2	6/2010	Al-Ali
7,096,054	B2	8/2006	Abdul-Hafiz et al.	7,761,127	B2	7/2010	Al-Ali et al.
7,132,641	B2	11/2006	Schulz et al.	7,761,128	B2	7/2010	Al-Ali et al.
7,142,901	B2	11/2006	Kiani et al.	7,764,982	B2	7/2010	Dalke et al.
7,149,561	B2	12/2006	Diab	D621,516	S	8/2010	Kiani et al.
7,186,966	B2	3/2007	Al-Ali	7,791,155	B2	9/2010	Diab
7,190,261	B2	3/2007	Al-Ali	7,801,581	B2	9/2010	Diab
7,215,984	B2	5/2007	Diab	7,822,452	B2	10/2010	Schurman et al.
7,215,986	B2	5/2007	Diab	RE41,912	E	11/2010	Parker
7,221,971	B2	5/2007	Diab	7,844,313	B2	11/2010	Kiani et al.
7,225,006	B2	5/2007	Al-Ali et al.	7,844,314	B2	11/2010	Al-Ali
7,225,007	B2	5/2007	Al-Ali	7,844,315	B2	11/2010	Al-Ali
RE39,672	E	6/2007	Shehada et al.	7,865,222	B2	1/2011	Weber et al.
7,239,905	B2	7/2007	Kiani-Azarbayjany et al.	7,873,497	B2	1/2011	Weber et al.
7,245,953	B1	7/2007	Parker	7,880,606	B2	2/2011	Al-Ali
7,254,429	B2	8/2007	Schurman et al.	7,880,626	B2	2/2011	Al-Ali et al.
7,254,431	B2	8/2007	Al-Ali	7,891,355	B2	2/2011	Al-Ali et al.
7,254,433	B2	8/2007	Diab et al.	7,894,868	B2	2/2011	Al-Ali et al.
7,254,434	B2	8/2007	Schulz et al.	7,899,507	B2	3/2011	Al-Ali et al.
7,272,425	B2	9/2007	Al-Ali	7,899,518	B2	3/2011	Trepagnier et al.
7,274,955	B2	9/2007	Kiani et al.	7,904,132	B2	3/2011	Weber et al.
D554,263	S	10/2007	Al-Ali	7,909,772	B2	3/2011	Popov et al.
7,280,858	B2	10/2007	Al-Ali et al.	7,910,875	B2	3/2011	Al-Ali
7,289,835	B2	10/2007	Mansfield et al.	7,919,713	B2	4/2011	Al-Ali et al.
7,292,883	B2	11/2007	De Felice et al.	7,937,128	B2	5/2011	Al-Ali
7,295,866	B2	11/2007	Al-Ali	7,937,129	B2	5/2011	Mason et al.
7,328,053	B1	2/2008	Diab et al.	7,937,130	B2	5/2011	Diab et al.
7,332,784	B2	2/2008	Mills et al.	7,941,199	B2	5/2011	Kiani
7,340,287	B2	3/2008	Mason et al.	7,957,780	B2	6/2011	Lamego et al.
7,341,559	B2	3/2008	Schulz et al.	7,962,188	B2	6/2011	Kiani et al.
7,343,186	B2	3/2008	Lamego et al.	7,962,190	B1	6/2011	Diab et al.
D566,282	S	4/2008	Al-Ali et al.	7,976,472	B2	7/2011	Kiani
7,355,512	B1	4/2008	Al-Ali	7,988,637	B2	8/2011	Diab
7,356,365	B2	4/2008	Schurman	7,990,382	B2	8/2011	Kiani
7,371,981	B2	5/2008	Abdul-Hafiz	7,991,446	B2	8/2011	Al-Ali et al.
7,373,193	B2	5/2008	Al-Ali et al.	8,000,761	B2	8/2011	Al-Ali
7,373,194	B2	5/2008	Weber et al.	8,008,088	B2	8/2011	Bellott et al.
7,376,453	B1	5/2008	Diab et al.	RE42,753	E	9/2011	Kiani-Azarbayjany et al.
7,377,794	B2	5/2008	Al Ali et al.	8,019,400	B2	9/2011	Diab et al.
7,377,899	B2	5/2008	Weber et al.	8,028,701	B2	10/2011	Al-Ali et al.
7,383,070	B2	6/2008	Diab et al.	8,029,765	B2	10/2011	Bellott et al.
7,415,297	B2	8/2008	Al-Ali et al.	8,036,728	B2	10/2011	Diab et al.
7,428,432	B2	9/2008	Ali et al.	8,046,040	B2	10/2011	Ali et al.
7,438,683	B2	10/2008	Al-Ali et al.	8,046,041	B2	10/2011	Diab et al.
7,440,787	B2	10/2008	Diab	8,046,042	B2	10/2011	Diab et al.
7,454,240	B2	11/2008	Diab et al.	8,048,040	B2	11/2011	Kiani
				8,050,728	B2	11/2011	Al-Ali et al.
				RE43,169	E	2/2012	Parker
				8,118,620	B2	2/2012	Al-Ali et al.
				8,126,528	B2	2/2012	Diab et al.

(56)

## References Cited

## U.S. PATENT DOCUMENTS

8,128,572 B2	3/2012	Diab et al.	8,581,732 B2	11/2013	Al-Ali et al.
8,130,105 B2	3/2012	Al-Ali et al.	8,584,345 B2	11/2013	Al-Ali et al.
8,145,287 B2	3/2012	Diab et al.	8,588,880 B2	11/2013	Abdul-Hafiz et al.
8,150,487 B2	4/2012	Diab et al.	8,600,467 B2	12/2013	Al-Ali et al.
8,175,672 B2	5/2012	Parker	8,606,342 B2	12/2013	Diab
8,180,420 B2	5/2012	Diab et al.	8,626,255 B2	1/2014	Al-Ali et al.
8,182,443 B1	5/2012	Kiani	8,630,691 B2	1/2014	Lamego et al.
8,185,180 B2	5/2012	Diab et al.	8,634,889 B2	1/2014	Al-Ali et al.
8,190,223 B2	5/2012	Al-Ali et al.	8,641,631 B2	2/2014	Sierra et al.
8,190,227 B2	5/2012	Diab et al.	8,652,060 B2	2/2014	Al-Ali
8,203,438 B2	6/2012	Kiani et al.	8,663,107 B2	3/2014	Kiani
8,203,704 B2	6/2012	Merritt et al.	8,666,468 B1	3/2014	Al-Ali
8,224,411 B2	7/2012	Al-Ali et al.	8,667,967 B2	3/2014	Al-Ali et al.
8,228,181 B2	7/2012	Al-Ali	8,670,811 B2	3/2014	O'Reilly
8,229,533 B2	7/2012	Diab et al.	8,670,814 B2	3/2014	Diab et al.
8,233,955 B2	7/2012	Al-Ali et al.	8,676,286 B2	3/2014	Weber et al.
8,244,325 B2	8/2012	Al-Ali et al.	8,682,407 B2	3/2014	Al-Ali
8,255,026 B1	8/2012	Al-Ali	RE44,823 E	4/2014	Parker
8,255,027 B2	8/2012	Al-Ali et al.	RE44,875 E	4/2014	Kiani et al.
8,255,028 B2	8/2012	Al-Ali et al.	8,690,799 B2	4/2014	Telfort et al.
8,260,577 B2	9/2012	Weber et al.	8,700,112 B2	4/2014	Kiani
8,265,723 B1	9/2012	McHale et al.	8,702,627 B2	4/2014	Telfort et al.
8,274,360 B2	9/2012	Sampath et al.	8,706,179 B2	4/2014	Parker
8,301,217 B2	10/2012	Al-Ali et al.	8,712,494 B1	4/2014	MacNeish, III et al.
8,310,336 B2	11/2012	Muhsin et al.	8,715,206 B2	5/2014	Telfort et al.
8,315,683 B2	11/2012	Al-Ali et al.	8,718,735 B2	5/2014	Lamego et al.
RE43,860 E	12/2012	Parker	8,718,737 B2	5/2014	Diab et al.
8,337,403 B2	12/2012	Al-Ali et al.	8,718,738 B2	5/2014	Blank et al.
8,346,330 B2	1/2013	Lamego	8,720,249 B2	5/2014	Al-Ali
8,353,842 B2	1/2013	Al-Ali et al.	8,721,541 B2	5/2014	Al-Ali et al.
8,355,766 B2	1/2013	MacNeish, III et al.	8,721,542 B2	5/2014	Al-Ali et al.
8,359,080 B2	1/2013	Diab et al.	8,723,677 B1	5/2014	Kiani
8,364,223 B2	1/2013	Al-Ali et al.	8,740,792 B1	6/2014	Kiani et al.
8,364,226 B2	1/2013	Diab et al.	8,754,776 B2	6/2014	Poeze et al.
8,374,665 B2	2/2013	Lamego	8,755,535 B2	6/2014	Telfort et al.
8,385,995 B2	2/2013	Al-Ali et al.	8,755,856 B2	6/2014	Diab et al.
8,385,996 B2	2/2013	Smith et al.	8,755,872 B1	6/2014	Marinow
8,388,353 B2	3/2013	Kiani et al.	8,761,850 B2	6/2014	Lamego
8,399,822 B2	3/2013	Al-Ali	8,764,671 B2	7/2014	Kiani
8,401,602 B2	3/2013	Kiani	8,768,423 B2	7/2014	Shakespeare et al.
8,405,608 B2	3/2013	Al-Ali et al.	8,771,204 B2	7/2014	Telfort et al.
8,414,499 B2	4/2013	Al-Ali et al.	8,777,634 B2	7/2014	Kiani et al.
8,418,524 B2	4/2013	Al-Ali	8,781,543 B2	7/2014	Diab et al.
8,423,106 B2	4/2013	Lamego et al.	8,781,544 B2	7/2014	Al-Ali et al.
8,428,967 B2	4/2013	Olsen et al.	8,781,549 B2	7/2014	Al-Ali et al.
8,430,817 B1	4/2013	Al-Ali et al.	8,788,003 B2	7/2014	Schurman et al.
8,437,825 B2	5/2013	Dalvi et al.	8,790,268 B2	7/2014	Al-Ali
8,455,290 B2	6/2013	Siskavich	8,801,613 B2	8/2014	Al-Ali et al.
8,457,703 B2	6/2013	Al-Ali	8,821,397 B2	9/2014	Al-Ali et al.
8,457,707 B2	6/2013	Kiani	8,821,415 B2	9/2014	Al-Ali et al.
8,463,349 B2	6/2013	Diab et al.	8,830,449 B1	9/2014	Lamego et al.
8,466,286 B2	6/2013	Bellot et al.	8,831,700 B2	9/2014	Schurman et al.
8,471,713 B2	6/2013	Poeze et al.	8,840,549 B2	9/2014	Al-Ali et al.
8,473,020 B2	6/2013	Kiani et al.	8,847,740 B2	9/2014	Kiani et al.
8,483,787 B2	7/2013	Al-Ali et al.	8,849,365 B2	9/2014	Smith et al.
8,489,364 B2	7/2013	Weber et al.	8,852,094 B2	10/2014	Al-Ali et al.
8,498,684 B2	7/2013	Weber et al.	8,852,994 B2	10/2014	Wojtczuk et al.
8,509,867 B2	8/2013	Workman et al.	8,868,147 B2	10/2014	Stippick et al.
8,515,509 B2	8/2013	Bruinsma et al.	8,868,150 B2	10/2014	Al-Ali et al.
8,523,781 B2	9/2013	Al-Ali	8,870,792 B2	10/2014	Al-Ali et al.
8,529,301 B2	9/2013	Al-Ali et al.	8,886,271 B2	11/2014	Kiani et al.
8,532,727 B2	9/2013	Ali et al.	8,888,539 B2	11/2014	Al-Ali et al.
8,532,728 B2	9/2013	Diab et al.	8,888,708 B2	11/2014	Diab et al.
D692,145 S	10/2013	Al-Ali et al.	8,892,180 B2	11/2014	Weber et al.
8,547,209 B2	10/2013	Kiani et al.	8,897,847 B2	11/2014	Al-Ali
8,548,548 B2	10/2013	Al-Ali	8,909,310 B2	12/2014	Lamego et al.
8,548,550 B2	10/2013	Al-Ali et al.	8,911,377 B2	12/2014	Al-Ali
8,560,032 B2	10/2013	Al-Ali et al.	8,912,909 B2	12/2014	Al-Ali et al.
8,560,034 B1	10/2013	Diab et al.	8,920,317 B2	12/2014	Al-Ali et al.
8,570,167 B2	10/2013	Al-Ali	8,921,699 B2	12/2014	Al-Ali et al.
8,570,503 B2	10/2013	Vo et al.	8,922,382 B2	12/2014	Al-Ali et al.
8,571,617 B2	10/2013	Reichgott et al.	8,929,964 B2	1/2015	Al-Ali et al.
8,571,618 B1	10/2013	Lamego et al.	8,942,777 B2	1/2015	Diab et al.
8,571,619 B2	10/2013	Al-Ali et al.	8,948,834 B2	2/2015	Diab et al.
8,577,431 B2	11/2013	Lamego et al.	8,948,835 B2	2/2015	Diab
			8,965,471 B2	2/2015	Lamego
			8,983,564 B2	3/2015	Al-Ali
			8,989,831 B2	3/2015	Al-Ali et al.
			8,996,085 B2	3/2015	Kiani et al.

(56)

## References Cited

## U.S. PATENT DOCUMENTS

8,998,809 B2 4/2015 Kiani  
 9,028,429 B2 5/2015 Telfort et al.  
 9,037,207 B2 5/2015 Al-Ali et al.  
 9,060,721 B2 6/2015 Reichgott et al.  
 9,066,666 B2 6/2015 Kiani  
 9,066,680 B1 6/2015 Al-Ali et al.  
 9,072,474 B2 7/2015 Al-Ali et al.  
 9,078,560 B2 7/2015 Schurman et al.  
 9,084,569 B2 7/2015 Weber et al.  
 9,095,316 B2 8/2015 Welch et al.  
 9,106,038 B2 8/2015 Telfort et al.  
 9,107,625 B2 8/2015 Telfort et al.  
 9,107,626 B2 8/2015 Al-Ali et al.  
 9,113,831 B2 8/2015 Al-Ali  
 9,113,832 B2 8/2015 Al-Ali  
 9,119,595 B2 9/2015 Lamego  
 2008/0157980 A1 7/2008 Sachanandani et al.  
 2009/0210163 A1 8/2009 Ochs et al.  
 2009/0247984 A1 10/2009 Lamego et al.  
 2009/0275844 A1 11/2009 Al-Ali  
 2009/0299157 A1 12/2009 Telfort et al.  
 2010/0004518 A1 1/2010 Vo et al.  
 2010/0030040 A1 2/2010 Poeze et al.  
 2010/0261979 A1 10/2010 Kiani  
 2011/0001605 A1 1/2011 Kiani et al.  
 2011/0082711 A1 4/2011 Poeze et al.  
 2011/0105854 A1 5/2011 Kiani et al.  
 2011/0208015 A1 8/2011 Welch et al.  
 2011/0209915 A1 9/2011 Telfort et al.  
 2011/0213212 A1 9/2011 Al-Ali  
 2011/0230733 A1 9/2011 Al-Ali  
 2011/0237911 A1 9/2011 Lamego et al.  
 2012/0059267 A1 3/2012 Lamego et al.  
 2012/0116175 A1 5/2012 Al-Ali et al.  
 2012/0179006 A1 7/2012 Jansen et al.  
 2012/0209082 A1 8/2012 Al-Ali  
 2012/0209084 A1 8/2012 Olsen et al.  
 2012/0227739 A1 9/2012 Kiani  
 2012/0265039 A1 10/2012 Kiani  
 2012/0283524 A1 11/2012 Kiani et al.  
 2012/0286955 A1 11/2012 Welch et al.  
 2012/0296178 A1 11/2012 Lamego et al.  
 2012/0319816 A1 12/2012 Al-Ali  
 2012/0330112 A1 12/2012 Lamego et al.  
 2013/0023775 A1 1/2013 Lamego et al.  
 2013/0041591 A1 2/2013 Lamego  
 2013/0045685 A1 2/2013 Kiani  
 2013/0046204 A1 2/2013 Lamego et al.  
 2013/0060108 A1 3/2013 Schurman et al.  
 2013/0060147 A1 3/2013 Welch et al.  
 2013/0096405 A1 4/2013 Garfio  
 2013/0096936 A1 4/2013 Sampath et al.  
 2013/0109935 A1 5/2013 Al-Ali et al.  
 2013/0162433 A1 6/2013 Muhsin et al.  
 2013/0190581 A1 7/2013 Al-Ali et al.  
 2013/0197328 A1 8/2013 Diab et al.  
 2013/0211214 A1 8/2013 Olsen  
 2013/0243021 A1 9/2013 Siskavich  
 2013/0253334 A1 9/2013 Al-Ali et al.  
 2013/0274571 A1 10/2013 Diab et al.  
 2013/0296672 A1 11/2013 O'Neil et al.  
 2013/0317370 A1 11/2013 Dalvi et al.  
 2013/0324808 A1 12/2013 Al-Ali et al.  
 2013/0331670 A1 12/2013 Kiani  
 2013/0338461 A1 12/2013 Lamego et al.  
 2014/0012100 A1 1/2014 Al-Ali et al.  
 2014/0025306 A1 1/2014 Weber et al.

2014/0034353 A1 2/2014 Al-Ali et al.  
 2014/0051952 A1 2/2014 Reichgott et al.  
 2014/0051953 A1 2/2014 Lamego et al.  
 2014/0051954 A1 2/2014 Al-Ali et al.  
 2014/0058230 A1 2/2014 Abdul-Hafiz et al.  
 2014/0066783 A1 3/2014 Kiani et al.  
 2014/0077956 A1 3/2014 Sampath et al.  
 2014/0081100 A1 3/2014 Muhsin et al.  
 2014/0081175 A1 3/2014 Telfort  
 2014/0094667 A1 4/2014 Schurman et al.  
 2014/0100434 A1 4/2014 Diab et al.  
 2014/0114199 A1 4/2014 Lamego et al.  
 2014/0120564 A1 5/2014 Workman et al.  
 2014/0121482 A1 5/2014 Merritt et al.  
 2014/0121483 A1 5/2014 Kiani  
 2014/0125495 A1 5/2014 Al-Ali  
 2014/0127137 A1 5/2014 Bellott et al.  
 2014/0128696 A1 5/2014 Al-Ali  
 2014/0128699 A1 5/2014 Al-Ali et al.  
 2014/0129702 A1 5/2014 Lamego et al.  
 2014/0135588 A1 5/2014 Al-Ali et al.  
 2014/0142401 A1 5/2014 Al-Ali et al.  
 2014/0142402 A1 5/2014 Al-Ali et al.  
 2014/0163344 A1 6/2014 Al-Ali  
 2014/0163402 A1 6/2014 Lamego et al.  
 2014/0166076 A1 6/2014 Kiani et al.  
 2014/0171763 A1 6/2014 Diab  
 2014/0180038 A1 6/2014 Kiani  
 2014/0180154 A1 6/2014 Sierra et al.  
 2014/0194709 A1 7/2014 Al-Ali et al.  
 2014/0194711 A1 7/2014 Al-Ali  
 2014/0194766 A1 7/2014 Al-Ali et al.  
 2014/0200420 A1 7/2014 Al-Ali  
 2014/0200422 A1 7/2014 Weber et al.  
 2014/0206963 A1 7/2014 Al-Ali  
 2014/0213864 A1 7/2014 Abdul-Hafiz et al.  
 2014/0243627 A1 8/2014 Diab et al.  
 2014/0266790 A1 9/2014 Al-Ali et al.  
 2014/0275808 A1 9/2014 Poeze et al.  
 2014/0275835 A1 9/2014 Lamego et al.  
 2014/0275871 A1 9/2014 Lamego et al.  
 2014/0275872 A1 9/2014 Merritt et al.  
 2014/0275881 A1 9/2014 Lamego et al.  
 2014/0288400 A1 9/2014 Diab et al.  
 2014/0296664 A1 10/2014 Bruinsma et al.  
 2014/0303520 A1 10/2014 Telfort et al.  
 2014/0309506 A1 10/2014 Lamego et al.  
 2014/0309559 A1 10/2014 Telfort et al.  
 2014/0316228 A1 10/2014 Blank et al.  
 2014/0323825 A1 10/2014 Al-Ali et al.  
 2014/0330092 A1 11/2014 Al-Ali et al.  
 2014/0330098 A1 11/2014 Merritt et al.  
 2014/0330099 A1 11/2014 Al-Ali et al.  
 2014/0333440 A1 11/2014 Kiani  
 2014/0336481 A1 11/2014 Shakespeare et al.  
 2014/0343436 A1 11/2014 Kiani  
 2015/0018650 A1 1/2015 Al-Ali et al.

## OTHER PUBLICATIONS

Coetzee, et al., "Noise-Resistant Pulse Oximetry Using a Synthetic Reference Signal," IEEE Transactions on Biomedical Engineering, IEEE Service Center, Piscataway, NJ, vol. 47, No. 8, dated Aug. 1, 2000.

Invitation to Pay Additional Fees document, including communication relating to the results of a partial Search Report issued in related application No. PCT/US2011/026545, dated Jun. 22, 2011, in 5 pages.

\* cited by examiner

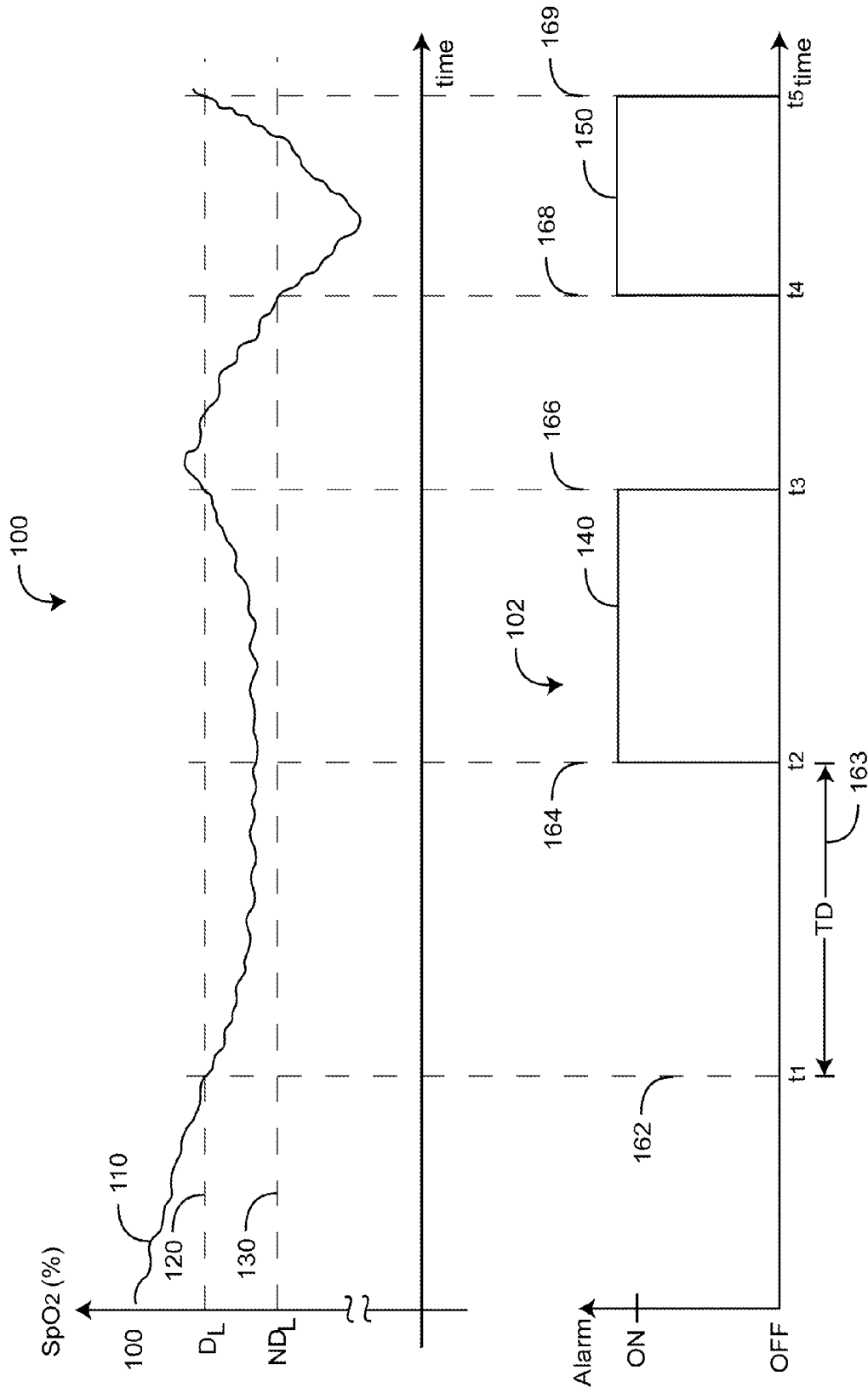

FIG. 1

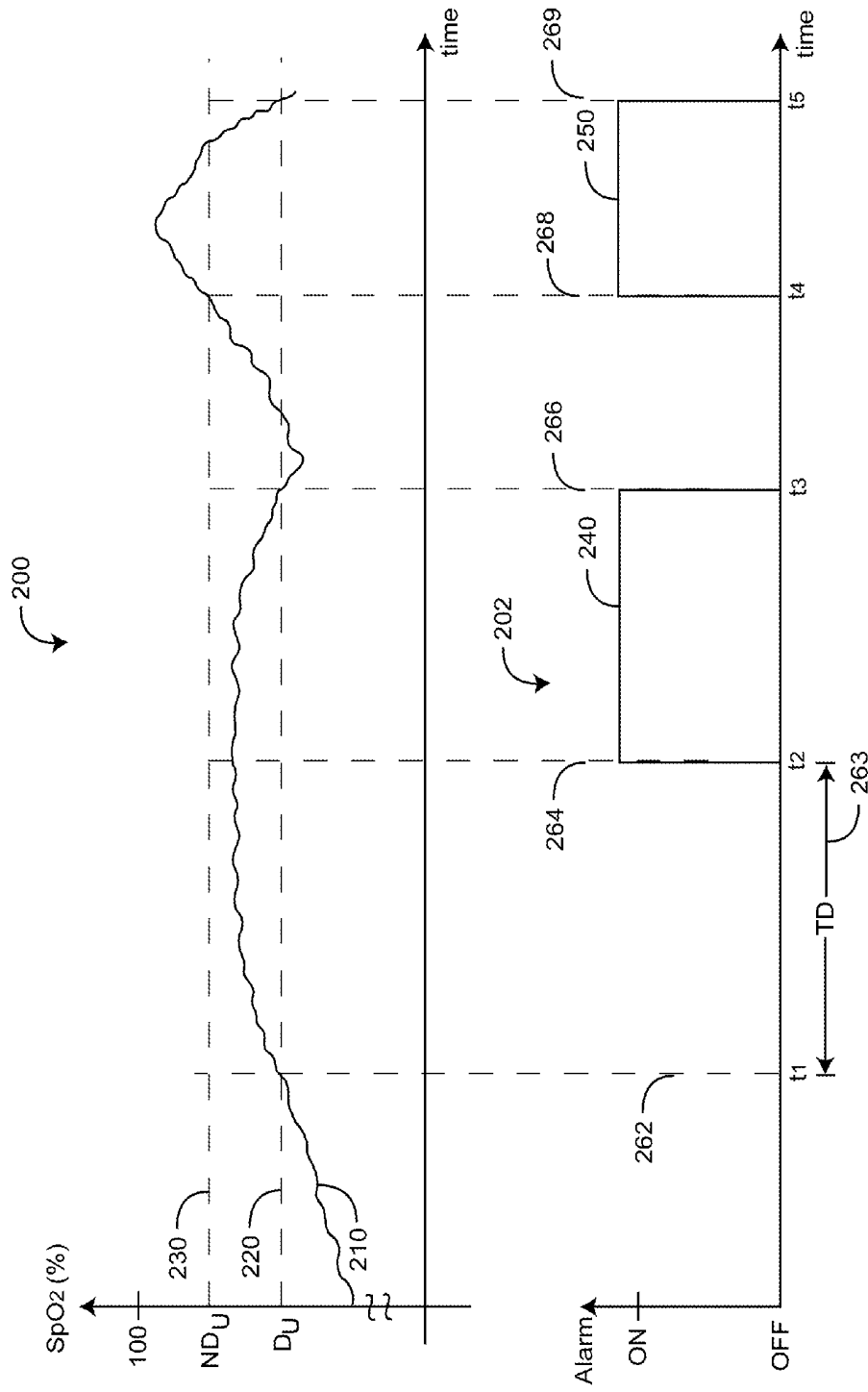

FIG. 2

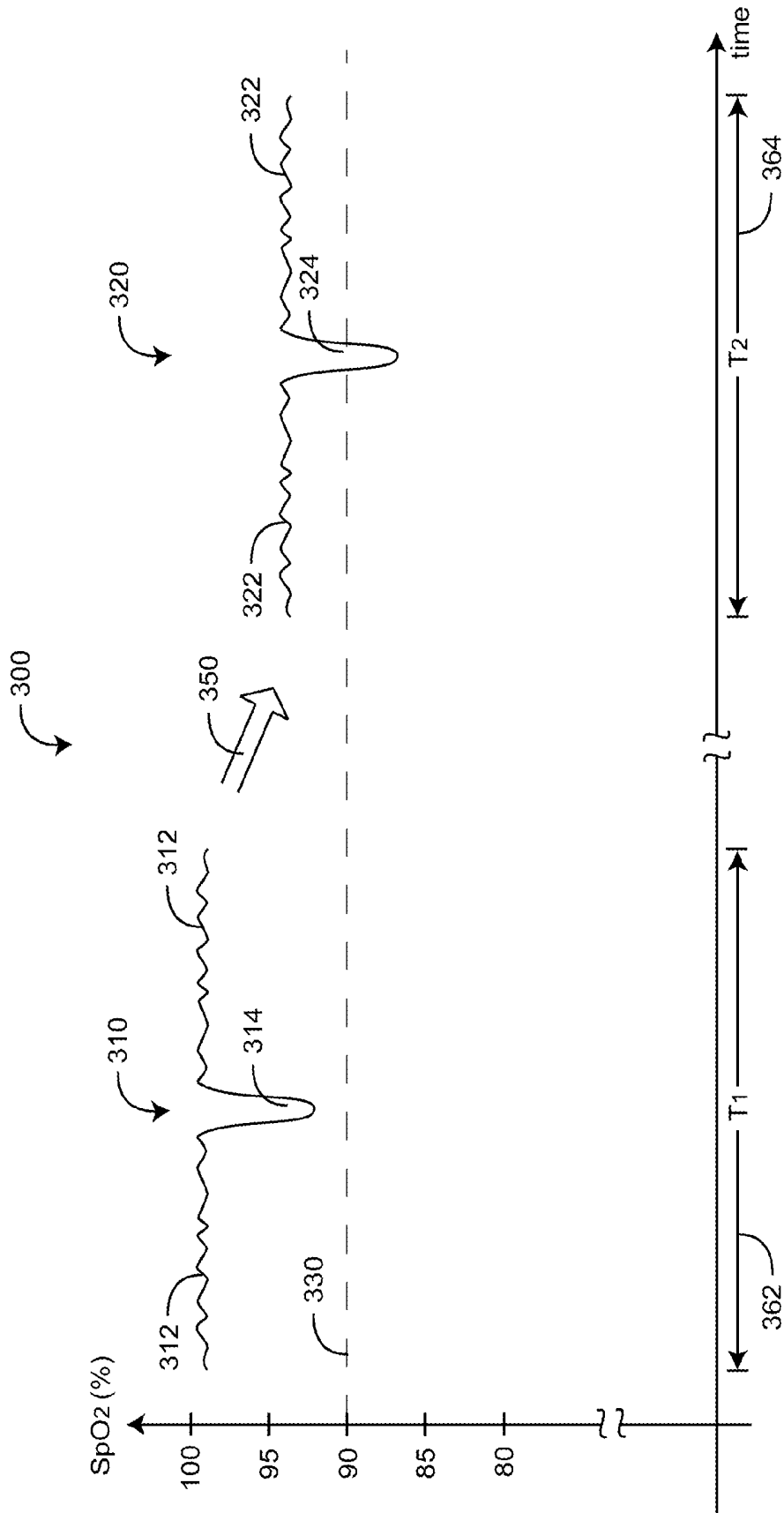

FIG. 3

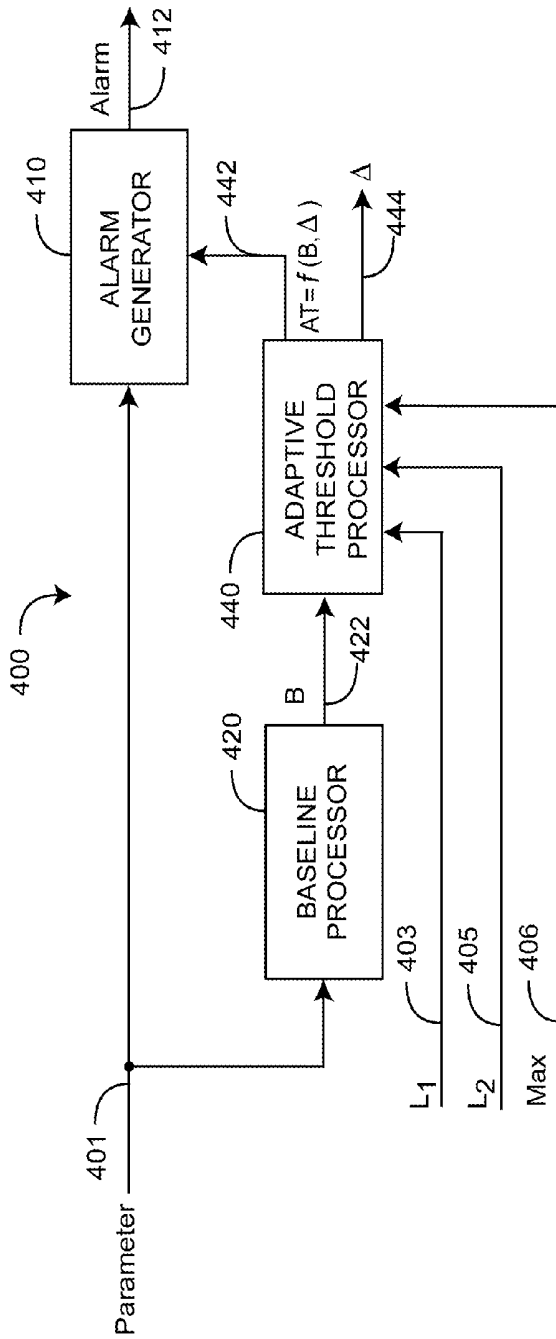

FIG. 4A

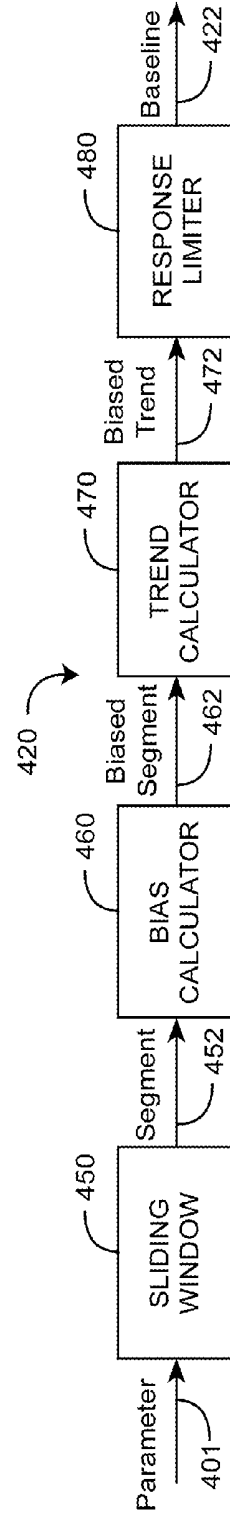

FIG. 4B

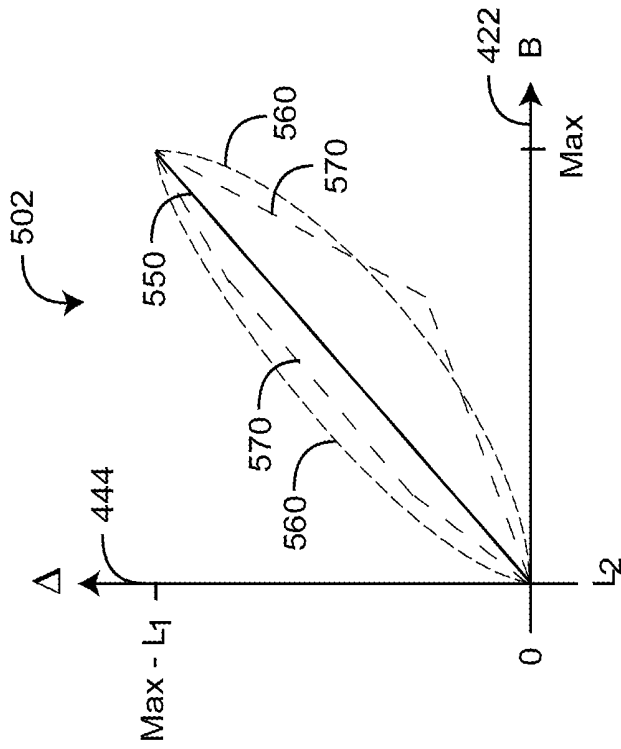

FIG. 5B

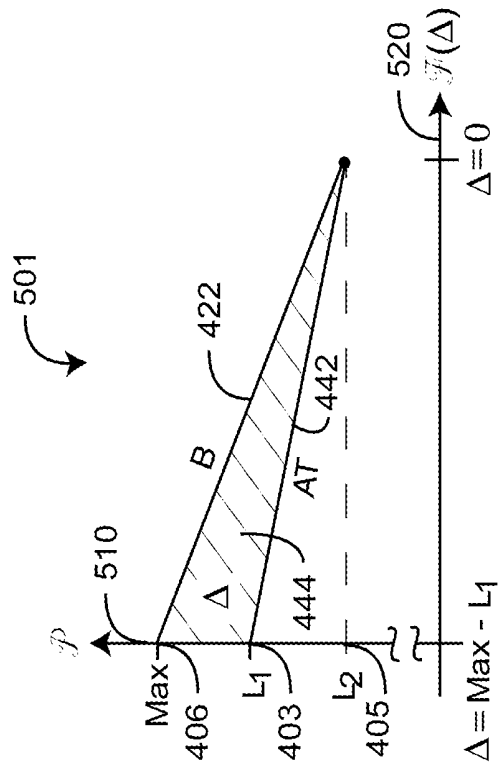

FIG. 5A

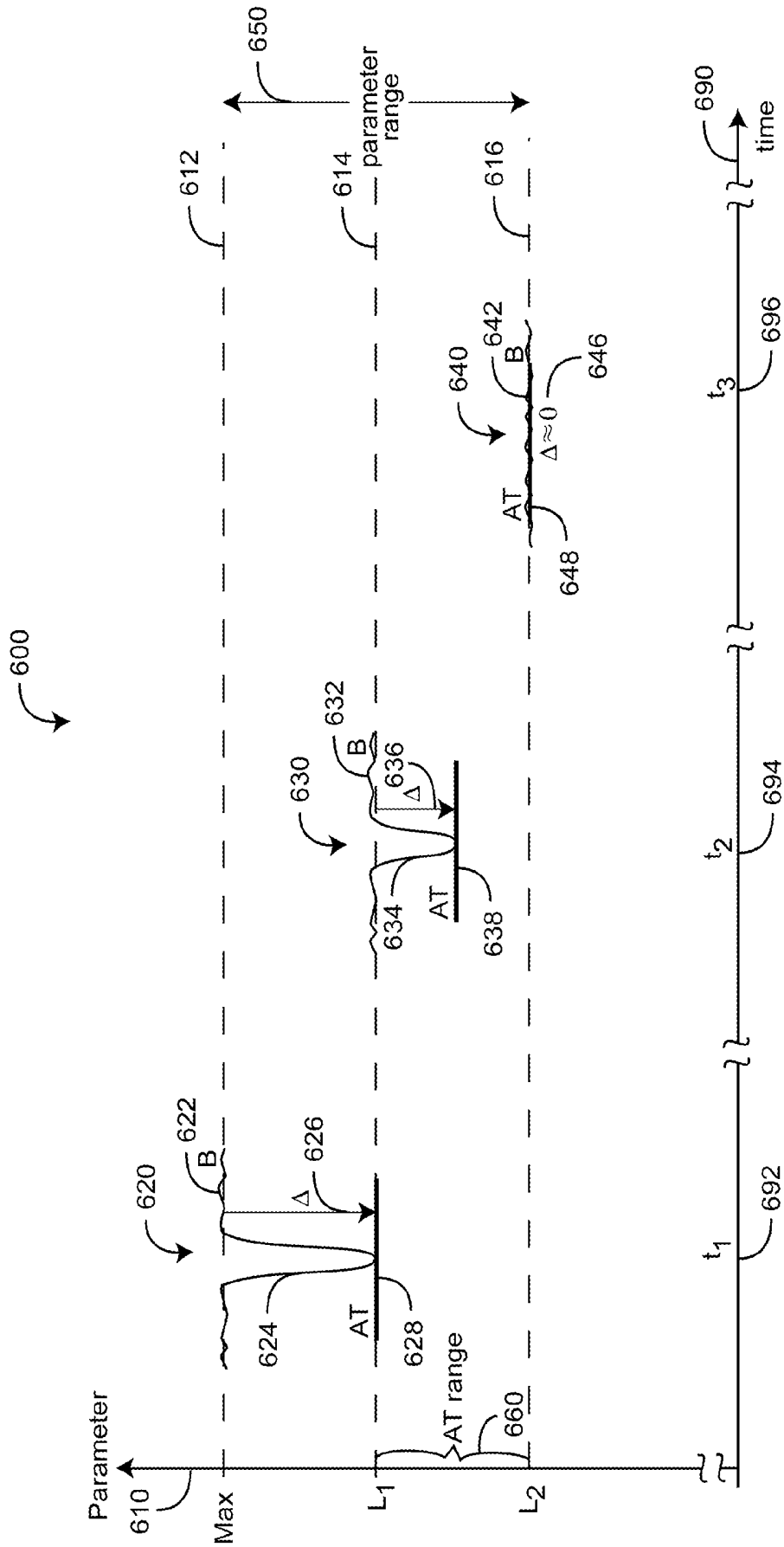

FIG. 6

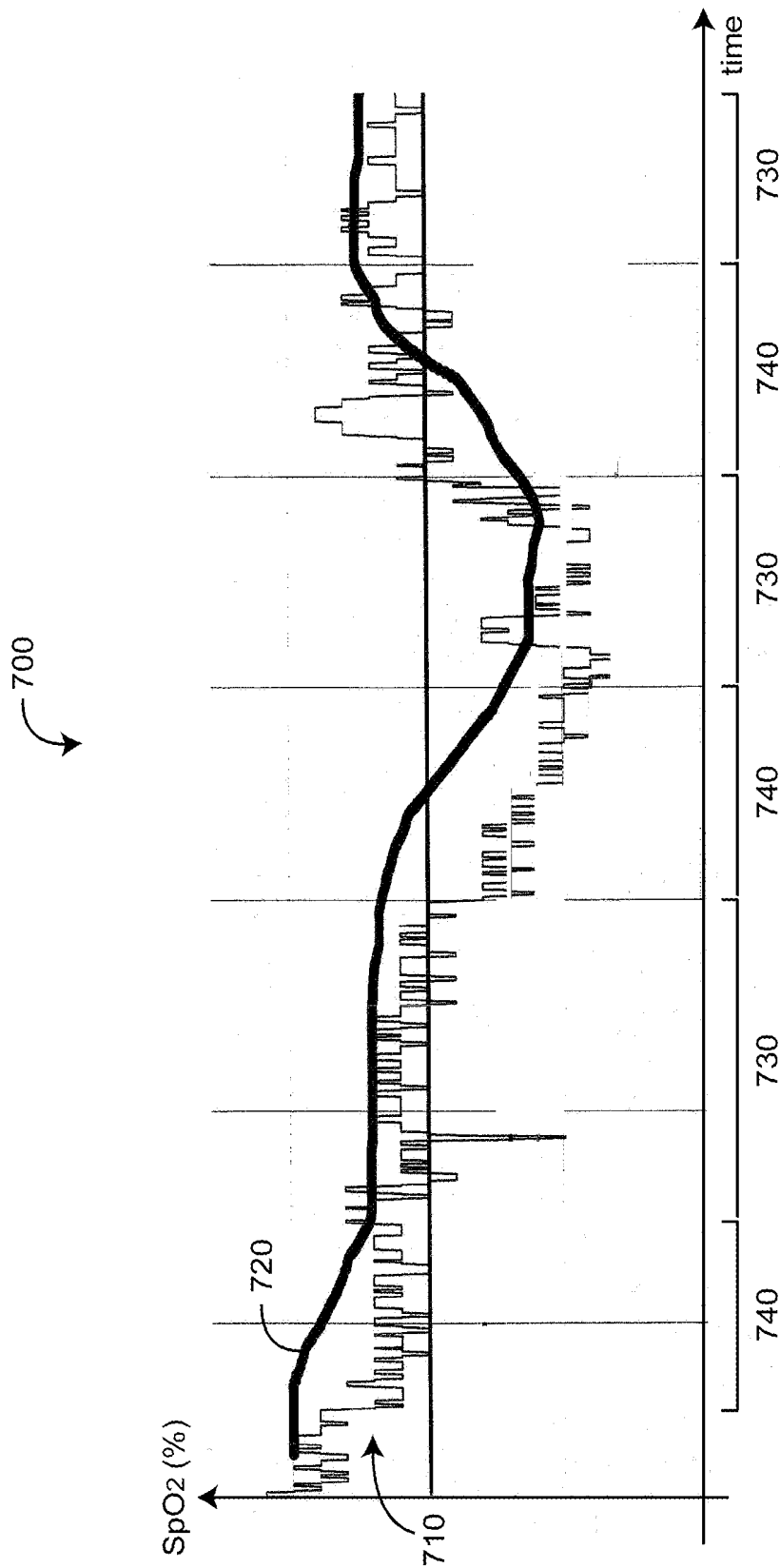

FIG. 7

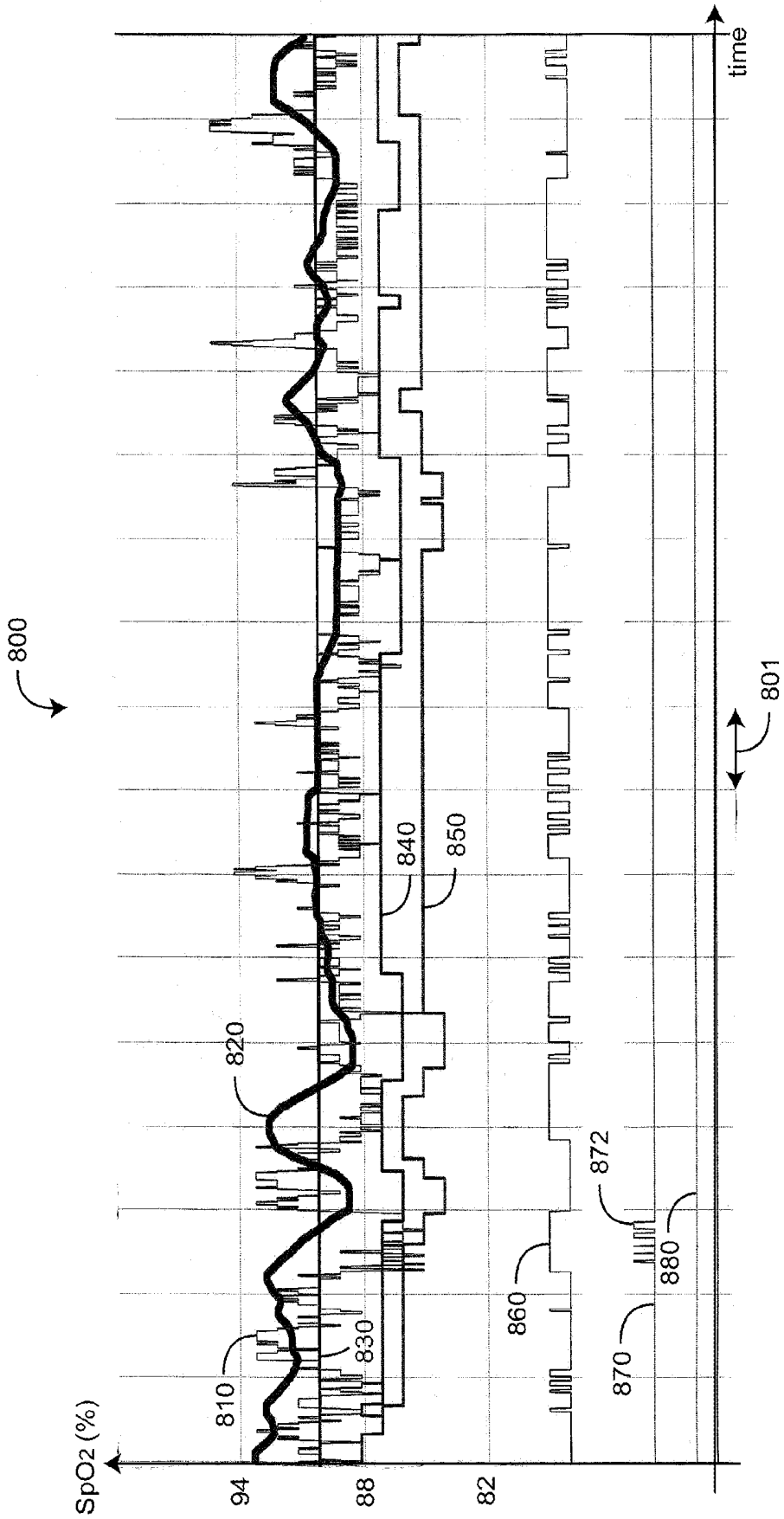

FIG. 8

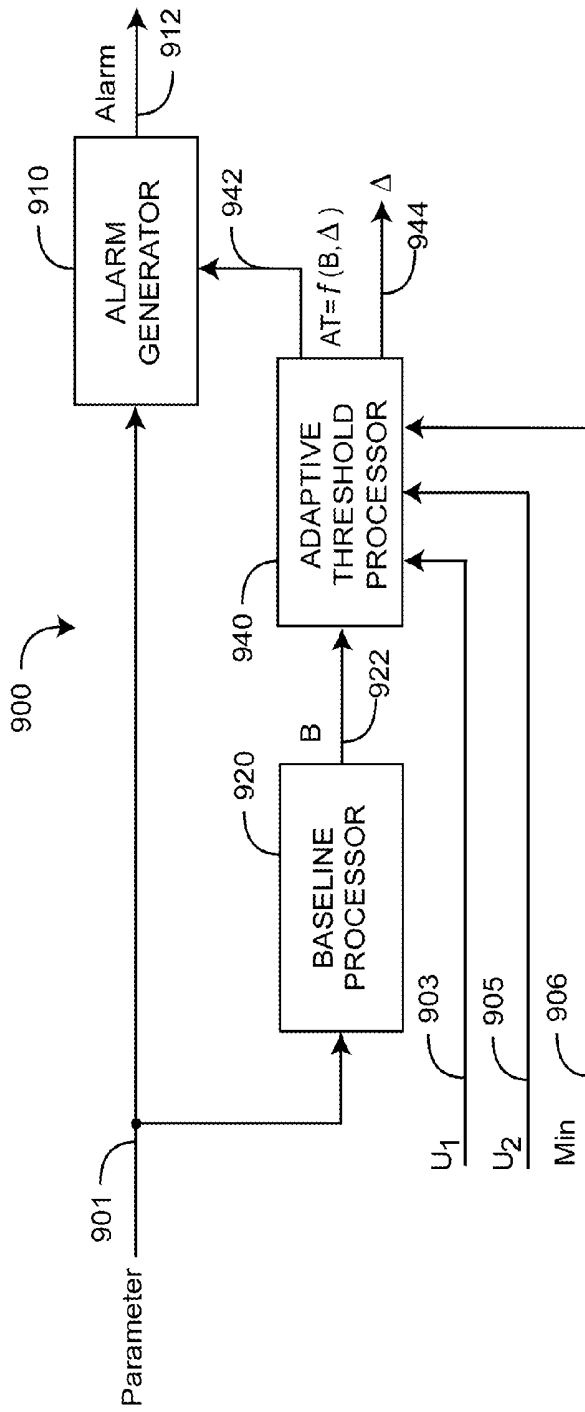

FIG. 9A

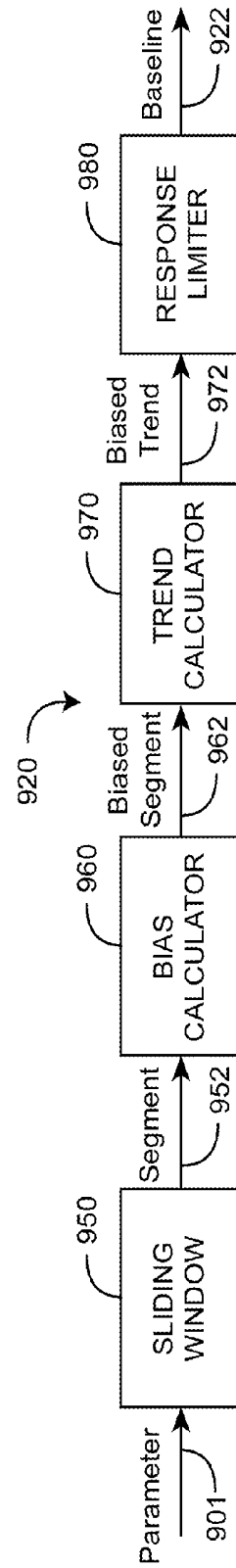

FIG. 9B

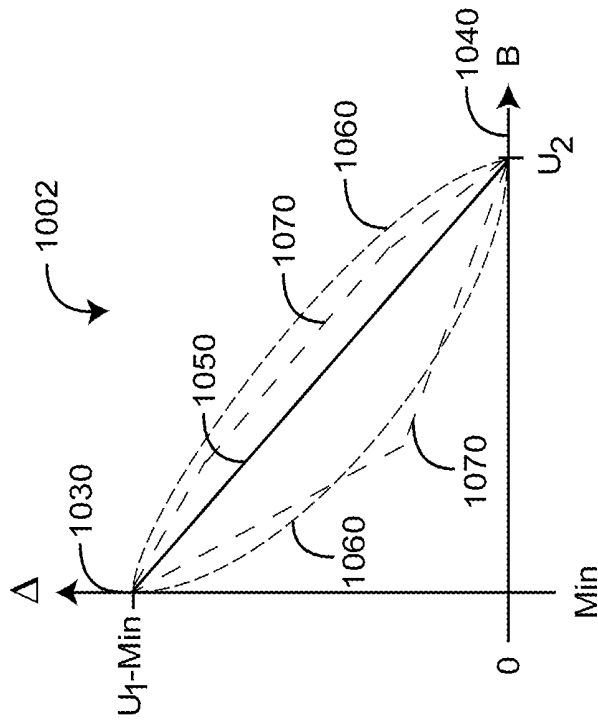

FIG. 10B

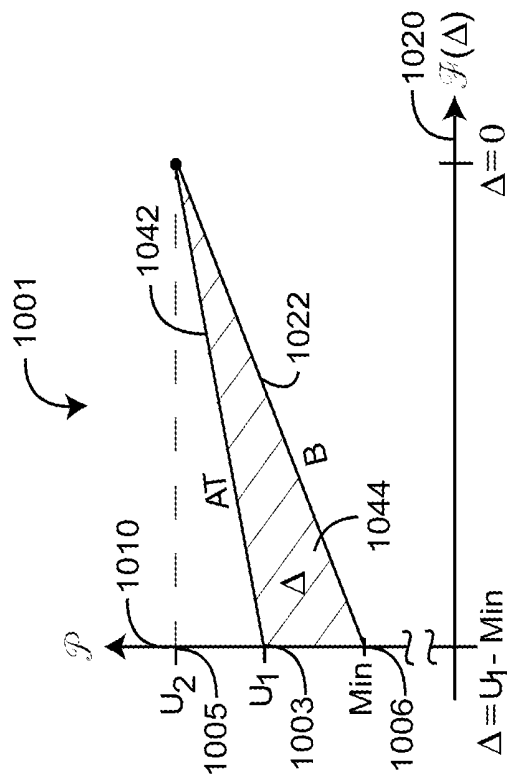

FIG. 10A



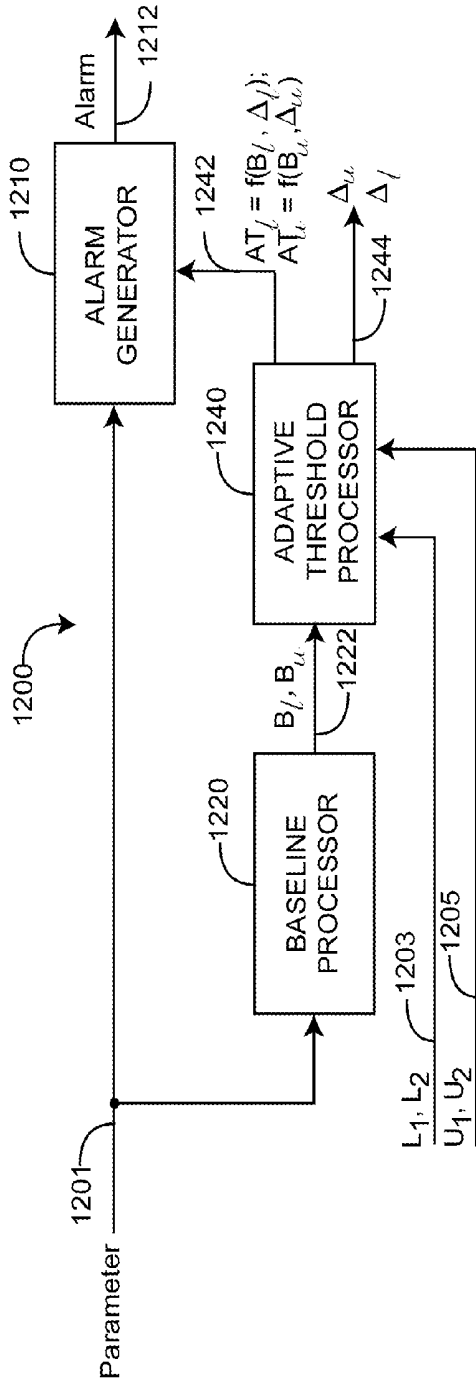

FIG. 12A

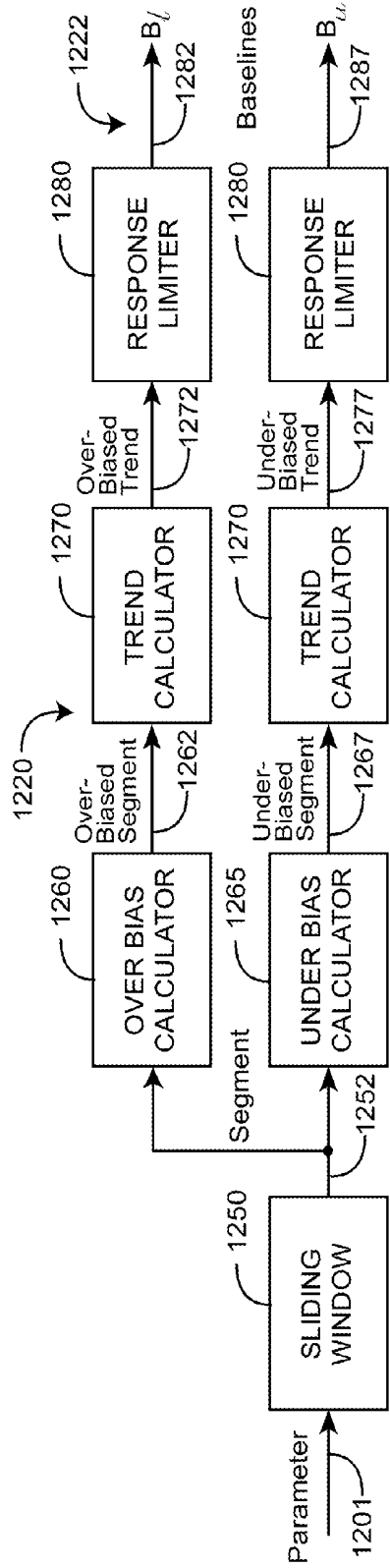

FIG. 12B

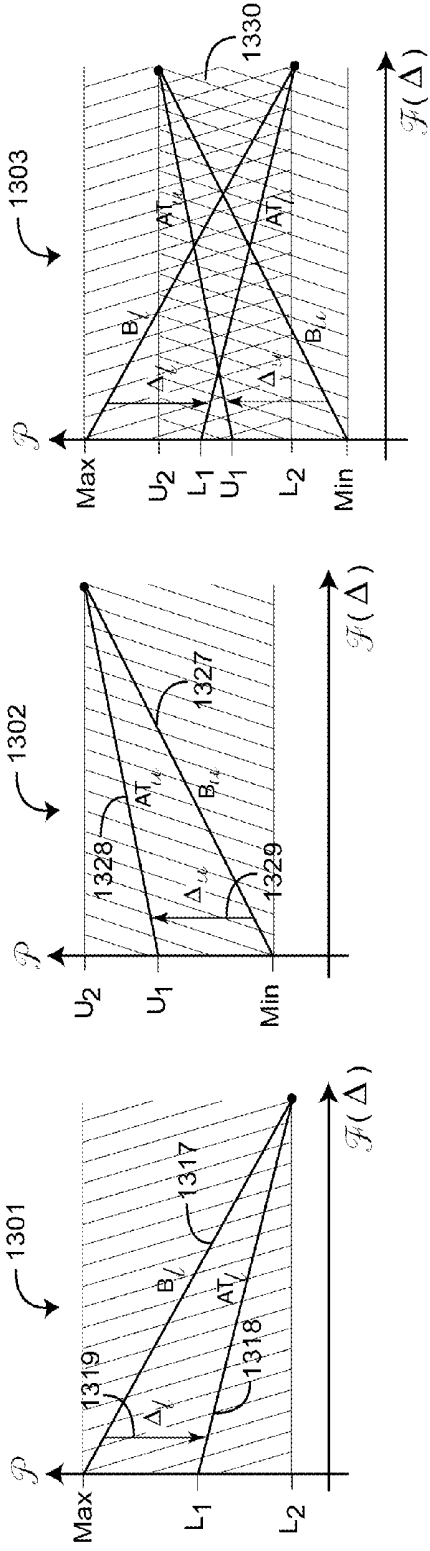

FIG. 13C

FIG. 13B

FIG. 13A

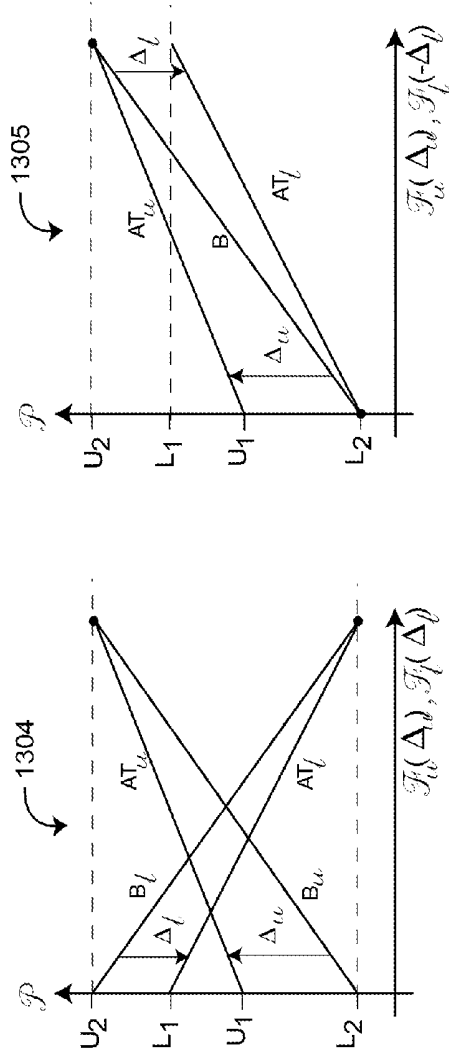

FIG. 13E

FIG. 13D



## ADAPTIVE ALARM SYSTEM

PRIORITY CLAIM TO RELATED  
PROVISIONAL APPLICATIONS

The present application claims priority benefit under 35 U.S.C. §119(e) to U.S. Provisional Patent Application Ser. No. 61/309,419, filed Mar. 1, 2010 titled Adaptive Threshold Alarm System; and U.S. Provisional Patent Application Ser. No. 61/328,630, filed Apr. 27, 2010 titled Adaptive Alarm System; all of the above-cited provisional patent applications are hereby incorporated by reference herein.

## BACKGROUND OF THE INVENTION

Pulse oximetry systems for measuring constituents of circulating blood have gained rapid acceptance in a wide variety of medical applications, including surgical wards, intensive care and neonatal units, general wards, home care, physical training, and virtually all types of monitoring scenarios. A pulse oximetry system generally includes an optical sensor applied to a patient, a monitor for processing sensor signals and displaying results and a patient cable electrically interconnecting the sensor and the monitor. A pulse oximetry sensor has light emitting diodes (LEDs), typically one emitting a red wavelength and one emitting an infrared (IR) wavelength, and a photodiode detector. The emitters and detector are typically attached to a finger, and the patient cable transmits drive signals to these emitters from the monitor. The emitters respond to the drive signals to transmit light into the fleshy fingertip tissue. The detector generates a signal responsive to the emitted light after attenuation by pulsatile blood flow within the fingertip. The patient cable transmits the detector signal to the monitor, which processes the signal to provide a numerical readout of physiological parameters such as oxygen saturation ( $SpO_2$ ) and pulse rate.

## SUMMARY OF THE INVENTION

Conventional pulse oximetry assumes that arterial blood is the only pulsatile blood flow in the measurement site. During patient motion, venous blood also moves, which causes errors in conventional pulse oximetry. Advanced pulse oximetry processes the venous blood signal so as to report true arterial oxygen saturation and pulse rate under conditions of patient movement. Advanced pulse oximetry also functions under conditions of low perfusion (small signal amplitude), intense ambient light (artificial or sunlight) and electrosurgical instrument interference, which are scenarios where conventional pulse oximetry tends to fail.

Advanced pulse oximetry is described in at least U.S. Pat. Nos. 6,770,028; 6,658,276; 6,157,850; 6,002,952; 5,769,785 and 5,758,644, which are assigned to Masimo Corporation ("Masimo") of Irvine, Calif. and are incorporated by reference herein. Corresponding low noise optical sensors are disclosed in at least U.S. Pat. Nos. 6,985,764; 6,813,511; 6,792,300; 6,256,523; 6,088,607; 5,782,757 and 5,638,818, which are also assigned to Masimo and are also incorporated by reference herein. Advanced pulse oximetry systems including Masimo SET® low noise optical sensors and read through motion pulse oximetry monitors for measuring  $SpO_2$ , pulse rate (PR) and perfusion index (PI) are available from Masimo. Optical sensors include any of Masimo LNOP®, LNCS®, SofTouch™ and Blue™ adhesive or

reusable sensors. Pulse oximetry monitors include any of Masimo Rad-8®, Rad-5®, Rad®-5v or SatShare® monitors.

Advanced blood parameter measurement systems are described in at least U.S. Pat. No. 7,647,083, filed Mar. 1, 2006, titled Multiple Wavelength Sensor Equalization; U.S. Pat. No. 7,729,733, filed Mar. 1, 2006, titled Configurable Physiological Measurement System; U.S. Pat. Pub. No. 2006/0211925, filed Mar. 1, 2006, titled Physiological Parameter Confidence Measure and U.S. Pat. Pub. No. 2006/0238358, filed Mar. 1, 2006, titled Noninvasive Multi-Parameter Patient Monitor, all assigned to Masimo Laboratories, Irvine, Calif. (Masimo Labs) and all incorporated by reference herein. An advanced parameter measurement system that includes acoustic monitoring is described in U.S. Pat. Pub. No. 2010/0274099, filed Dec. 21, 2009, titled Acoustic Sensor Assembly, assigned to Masimo and incorporated by reference herein.

Advanced blood parameter measurement systems include Masimo Rainbow® SET, which provides measurements in addition to  $SpO_2$ , such as total hemoglobin ( $SpHb^{TM}$ ), oxygen content ( $SpOC^{TM}$ ), methemoglobin ( $SpMet^{®}$ ), carboxyhemoglobin ( $SpCO^{®}$ ) and  $PVI^{®}$ . Advanced blood parameter sensors include Masimo Rainbow® adhesive, ReSposable™ and reusable sensors. Advanced blood parameter monitors include Masimo Radical-7™, Rad-87™ and Rad-57™ monitors, all available from Masimo. Advanced parameter measurement systems may also include acoustic monitoring such as acoustic respiration rate ( $RRa^{TM}$ ) using a Rainbow Acoustic Sensor™ and Rad-87™ monitor, available from Masimo. Such advanced pulse oximeters, low noise sensors and advanced physiological parameter measurement systems have also gained rapid acceptance in a wide variety of medical applications, including surgical wards, intensive care and neonatal units, general wards, home care, physical training, and virtually all types of monitoring scenarios.

FIGS. 1-3 illustrate problems and issues associated with physiological parameter measurement systems having fixed threshold alarm schemas. FIG. 1 illustrates a lower-limit, fixed-threshold alarm schema with respect to an oxygen saturation ( $SpO_2$ ) parameter. Two alarm thresholds,  $D_L$  (delay) and  $ND_L$  (no delay), are defined. If oxygen saturation falls below  $D_L$  for a time delay greater than TD, an alarm is triggered. If oxygen saturation falls below  $ND_L$  an alarm is immediately triggered.  $D_L$  120 is typically set around or somewhat above 90% oxygen saturation and  $ND_L$  130 is typically set at 5% to 10% below  $D_L$ . For example, say a person's oxygen saturation 110 drops below  $D_L$  120 at  $t=t_1$  162 and stays below  $D_L$  for at least a time delay TD 163. This triggers a delayed alarm 140 at  $t=t_2$  164, where  $t_2=t_1+TD$ . The alarm 140 remains active until oxygen saturation 110 rises above  $D_L$  120 at  $t=t_3$  166. As another example, say that oxygen saturation 110 then drops below  $ND_L$  130, which triggers an immediate alarm 150 at  $t=t_4$  168. The alarm 150 remains active until oxygen saturation 110 rises above  $D_L$  120 at  $t=t_5$  169.

FIG. 2 illustrates an upper-limit, fixed-threshold alarm schema with respect to an oxygen saturation ( $SpO_2$ ) parameter. This alarm scenario is particularly applicable to the avoidance of ROP (retinopathy of prematurity). Again, two alarm thresholds,  $D_U$  (delay) and  $ND_U$  (no delay), are defined.  $D_U$  220 might be set at or around 85% oxygen saturation and  $ND_U$  230 might be set at or around 90% oxygen saturation. For example, a neonate's oxygen saturation 210 rises above  $D_U$  220 at  $t=t_1$  262 and stays above  $D_U$  for at least a time delay TD 263. This triggers a delayed

alarm 240 at  $t=t_2$  264, where  $t_2=t_1+TD$ . The alarm 240 remains active until oxygen saturation 210 falls below  $D_U$  220 at  $t=t_3$  166. Oxygen saturation 210 then rises above  $ND_U$  230, which triggers an immediate alarm 250 at  $t=t_4$  268. The alarm 250 remains active until oxygen saturation 210 falls below  $D_U$  220 at  $t=t_5$  269.

FIG. 3 illustrates a baseline drift problem with the fixed threshold alarm schema described above. A person's oxygen saturation is plotted on an oxygen saturation ( $SpO_2$ ) versus time graph 300. In particular, during a first time interval  $T_1$  362, a person has an oxygen saturation 310 with a relatively stable "baseline" 312 punctuated by a shallow, transient desaturation event 314. This scenario may occur after the person has been on oxygen so that baseline oxygen saturation is near 100%. Accordingly, with a fixed threshold alarm 330 set at, say, 90%, the transient event 314 does not trigger a nuisance alarm. However, the effects of oxygen treatments wear off over time and oxygen saturation levels drift downward 350. In particular, during a second time interval  $T_2$  364, a person has an oxygen saturation 320 with a relatively stable baseline 322. The later baseline 322 is established at a substantially lower oxygen saturation than the earlier baseline 312. In this scenario, a shallow, transient desaturation event 324 now exceeds the alarm threshold 330 and results in a nuisance alarm. After many such nuisance alarms, a caregiver may lower the alarm threshold 330 to unsafe levels or turn off alarms altogether, significantly hampering the effectiveness of monitoring oxygen saturation.

A fixed threshold alarm schema is described above with respect to an oxygen saturation parameter, such as derived from a pulse oximeter. However, problematic fixed threshold alarm behavior may be exhibited in a variety of parameter measurement systems that calculate physiological parameters related to circulatory, respiratory, neurological, gastrointestinal, urinary, immune, musculoskeletal, endocrine or reproductive systems, such as the circulatory and respiratory parameters cited above, as but a few examples.

An adaptive alarm system, as described in detail below, advantageously provides an adaptive threshold alarm to solve false alarm and missed true alarm problems associated with baseline drift among other issues. For example, for a lower limit embodiment, an adaptive alarm system adjusts an alarm threshold downwards when a parameter baseline is established at lower values. Likewise, for an upper limit embodiment, the adaptive alarm system adjusts an alarm threshold upwards in accordance with baseline drift so as to avoid nuisance alarms. In an embodiment, the rate of baseline movement is limited so as to avoid masking of transients. In an embodiment, the baseline is established along upper or lower portions of a parameter envelop so as to provide a margin of safety in lower limit or upper limit systems, respectively.

One aspect of an adaptive alarm system is responsive to a physiological parameter so as to generate an alarm threshold that adapts to baseline drift in the parameter and reduce false alarms without a corresponding increase in missed true alarms. The adaptive alarm system has a parameter derived from a physiological measurement system using a sensor in communication with a living being. A baseline processor calculates a parameter baseline from an average value of the parameter. Parameter limits specify an allowable range of the parameter. An adaptive threshold processor calculates an adaptive threshold from the parameter baseline and the parameter limits. An alarm generator is responsive to the parameter and the adaptive threshold so as to trigger an alarm indicative of the parameter crossing the adaptive

threshold. The adaptive threshold is responsive to the parameter baseline so as to increase in value as the parameter baseline drifts to a higher parameter value and to decrease in value as the parameter baseline drifts to a lower parameter value.

In various embodiments, the baseline processor has a sliding window that identifies a time slice of parameter values. A trend calculator determines a trend from an average of the parameter values in the time slice. A response limiter tracks only the relatively long-term transitions of the trend. A bias calculator deletes the highest parameter values in the time slice or the lowest parameter values in the time slice so as to adjust the baseline to either a lower value or a higher value, respectively. The adaptive threshold becomes less responsive to baseline drift as the baseline approaches a predefined parameter limit. A first adaptive threshold is responsive to lower parameter limits and a second adaptive threshold is responsive to upper parameter limits. The alarm generator is responsive to both positive and negative transients from the baseline according to the first adaptive threshold and the second adaptive threshold. The first adaptive threshold is increasingly responsive to negative transients and the second adaptive threshold is decreasingly responsive to positive transients as the baseline trends toward lower parameter values.

Another aspect of an adaptive alarm system measures a physiological parameter, establishes a baseline for the parameter, adjusts an alarm threshold according to drift of the baseline and triggers an alarm in response to the parameter measurement crossing the alarm threshold. In various embodiments, the baseline is established by biasing a segment of the parameter, calculating a biased trend from the biased segment and restricting the transient response of the biased trend. The alarm threshold is adjusted by setting a parameter limit and calculating a delta difference between the alarm threshold and the baseline as a linear function of the baseline according to the parameter limit. The delta difference is calculated by decreasing delta as the baseline drifts toward the parameter limit and increasing delta as the baseline drifts away from the parameter limit. A parameter limit is set by selecting a first parameter limit in relation to a delayed alarm and selecting a second parameter limit in relation to an un-delayed alarm. A segment of the parameter is biased by windowing the parameter measurements, removing a lower value portion of the windowed parameter measurements and averaging a remaining portion of the windowed parameter measurements. An upper delta difference between an upper alarm threshold and the baseline is calculated and a lower delta difference between a lower alarm threshold and the baseline is calculated.

A further aspect of an adaptive alarm system has a baseline processor that inputs a parameter and outputs a baseline according to a trend of the parameter. An adaptive threshold processor establishes an alarm threshold at a delta difference from the baseline. An alarm generator triggers an alarm based upon a parameter transient from the baseline crossing the alarm threshold. In various embodiments, a trend calculator outputs a biased trend and the baseline is responsive to the biased trend so as to reduce the size of a transient that triggers the alarm. A response limiter reduces baseline movement due to parameter transients. The adaptive threshold processor establishes a lower alarm threshold below the baseline and an upper alarm threshold above the baseline so that the alarm generator is responsive to both positive and negative transients from the baseline. The baseline processor establishes a lower baseline biased above the parameter trend and an upper baseline biased below the

parameter trend. The lower alarm threshold is increasingly responsive to negative transients and the upper alarm threshold is decreasingly responsive to positive transients as the baseline trends toward lower parameter values.

#### DESCRIPTION OF THE DRAWINGS

FIGS. 1-3 are exemplar graphs illustrating problems and issues associated with physiological parameter measurement systems having fixed threshold alarm schemas;

FIGS. 4A-B are general block diagrams of an adaptive alarm system having lower parameter limits;

FIGS. 5A-B are a graph of a physiological parameter versus delta space and a graph of delta versus baseline, respectively, illustrating the relationship between a baseline, a lower-limit adaptive threshold and a variable difference delta between the baseline and the adaptive threshold;

FIG. 6 is an exemplar graph of a physiological parameter versus time illustrating an adaptive alarm system having a lower-limit adaptive threshold;

FIG. 7 is a graph of oxygen saturation versus time illustrating a baseline for determining an adaptive threshold;

FIG. 8 is a graph of oxygen saturation versus time comparing adaptive-threshold alarm performance with fixed-threshold alarm performance;

FIGS. 9A-B are general block diagrams of an adaptive alarm system having upper parameter limits;

FIGS. 10A-B are a graph of a physiological parameter versus delta space and a graph of delta versus baseline, respectively, illustrating the relationship between a baseline, an upper-limit adaptive threshold and a variable delta difference between the baseline and the adaptive threshold;

FIG. 11 is an exemplar graph of a physiological parameter versus time illustrating an adaptive alarm system having an upper-limit adaptive threshold;

FIGS. 12A-B are general block diagrams of an adaptive alarm system having both lower alarm limits and upper alarm limits;

FIGS. 13A-E are physiological parameter versus delta space graphs illustrating a lower-limit adaptive threshold, an upper-limit adaptive threshold, and a combined lower- and upper-limit adaptive threshold in various delta spaces; and

FIG. 14 is an exemplar graph of a physiological parameter versus time illustrating an adaptive alarm system having both lower and upper alarm limits.

#### DETAILED DESCRIPTION OF THE PREFERRED EMBODIMENTS

FIGS. 4A-B illustrate an adaptive alarm system 400 embodiment having lower parameter limits  $L_1$  and  $L_2$ . As shown in FIG. 4A, the adaptive alarm system 400 has parameter 401, first limit ( $L_1$ ) 403, second limit ( $L_2$ ) 405 and maximum parameter value (Max) 406 inputs and generates a corresponding alarm 412 output. The parameter 401 input is generated by a physiological parameter processor, such as a pulse oximeter or an advanced blood parameter processor described above, as examples. The adaptive alarm system 400 has an alarm generator 410, a baseline processor 420, and an adaptive threshold processor 440. The alarm generator 410 has parameter 401 and adaptive threshold (AT) 442 inputs and generates the alarm 412 output accordingly. A baseline processor 420 has the parameter 401 input and generates a parameter baseline (B) 422 output. The baseline processor 420, is described in detail with respect to FIG. 4B, below. An adaptive threshold processor 440 has parameter baseline (B) 422,  $L_1$  403,  $L_2$  405 and Max 406 inputs and

generates the adaptive threshold (AT) 442. The adaptive threshold processor 440 is described in detail with respect to FIGS. 5A-B, below.

As shown in FIG. 4A, in an embodiment  $L_1$  403 and  $L_2$  405 may correspond to conventional fixed alarm thresholds with and without an alarm time delay, respectively. For an adaptive threshold schema, however,  $L_1$  403 and  $L_2$  405 do not determine an alarm threshold per se, but are reference levels for determining an adaptive threshold (AT) 442. In an embodiment,  $L_1$  403 is an upper limit of the adaptive alarm threshold AT when the baseline is near the maximum parameter value (Max), and  $L_2$  405 is a lower limit of the adaptive alarm threshold, as described in detail with respect to FIGS. 5A-B, below. In an exemplar embodiment when the parameter is oxygen saturation,  $L_1$  403 is set at or around 90% and  $L_2$  405 is set at 5 to 10% below  $L_1$ , i.e. at 85% to 80% oxygen saturation. Many other  $L_1$  and  $L_2$  values may be used for an adaptive threshold schema as described herein.

Also shown in FIG. 4A, in an embodiment the alarm 412 output is triggered when the parameter 401 input falls below AT 442 and ends when the parameter 401 input rises above AT 442 or is otherwise cancelled. In an embodiment, the alarm 412 output is triggered after a time delay (TD), which may be fixed or variable. In an embodiment, the time delay (TD) is a function of the adaptive threshold (AT) 442. In an embodiment, the time delay (TD) is zero when the adaptive threshold (AT) is at the second lower limit ( $L_2$ ) 405.

As shown in FIG. 4B, a baseline processor 420 embodiment has a sliding window 450, a bias calculator 460, a trend calculator 470 and a response limiter 480. The sliding window 450 inputs the parameter 401 and outputs a time segment 452 of the parameter 401. In an embodiment, each window incorporates a five minute span of parameter values. The bias calculator 460 advantageously provides an upward shift in the baseline (B) 422 for an additional margin of error over missed true alarms. That is, a baseline 422 is generated that tracks a higher-than-average range of parameter values, effectively raising the adaptive threshold AT slightly above a threshold calculated based upon a true parameter average, as shown and described in detail with respect to FIGS. 7-8, below. In an embodiment, the bias calculator 460 rejects a lower range of parameter values from each time segment 452 from the sliding window so as to generate a biased time segment 462.

Also shown in FIG. 4B, the trend calculator 470 outputs a biased trend 472 of the remaining higher range of parameter values in each biased segment 462. In an embodiment, the biased trend 462 is an average of the values in the biased time segment 462. In other embodiments, the biased trend 462 is a median or mode of the values in the biased time segment 462. The response limiter 480 advantageously limits the extent to which the baseline 422 output tracks the biased trend 472. Accordingly, the baseline 422 tracks only relatively longer-lived transitions of the parameter, but does not track (and hence mask) physiologically significant parameter events, such as oxygen desaturations for a  $SpO_2$  parameter to name but one example. In an embodiment, the response limiter 480 has a low pass transfer function. In an embodiment, the response limiter 480 is a slow rate limiter.

FIGS. 5A-B further illustrate an adaptive threshold processor 440 (FIG. 4A) having a baseline (B) 422 input and generating an adaptive threshold (AT) 442 output and a delta ( $\Delta$ ) 444 ancillary output according to parameter limits  $L_1$  403,  $L_2$  405 and Max 406, as described above. As shown in FIG. 5A, as the baseline (B) 422 decreases (increases) the adaptive threshold (AT) 444 monotonically decreases (increases) between  $L_1$  403 and  $L_2$  405. Further, as the baseline

(B) **422** decreases (increases) the delta ( $\Delta$ ) **444** difference between the baseline (B) **422** and the adaptive threshold (AT) **442** monotonically decreases (increases) between  $\text{Max}-L_1$  and zero.

As shown in FIG. 5B, the relationship between the delta ( $\Delta$ ) **444** and the baseline (B) **444** may be linear **550** (solid line), non-linear **560** (small-dash lines) or piecewise-linear (large-dash lines), to name a few. In an embodiment, the adaptive threshold processor **440** (FIG. 4A) calculates an adaptive threshold (AT) **442** output in response to the baseline (B) **422** input according to a linear relationship. In a linear embodiment, the adaptive threshold processor **440** (FIG. 4A) calculates the adaptive threshold (AT) **442** according to EQS. 1-2:

$$\Delta = -\left(\frac{\text{Max} - L_1}{\text{Max} - L_2}\right)(\text{Max} - B) + (\text{Max} - L_1) \quad (1)$$

$$\text{AT} = B - \Delta \quad (2)$$

where  $\Delta = \text{Max} - L_1$  @  $B = \text{Max}$ ;  $\Delta = 0$  @  $B = L_2$  and where  $\text{AT} = L_1$  @  $B = \text{Max}$ ;  $\text{AT} = L_2$  @  $B = L_2$ , accordingly.

FIG. 6 illustrates the operational characteristics an adaptive alarm system **400** (FIG. 4A) having parameter limits  $\text{Max}$  **612**,  $L_1$  **614** and  $L_2$  **616** and an alarm responsive to a baseline (B) **622**, **632**, **642**; an adaptive threshold (AT) **628**, **638**, **648**; and a corresponding  $\Delta$  **626**, **636**, **646** according to EQS. 1-2, above. In particular, a physiological parameter **610** is graphed versus time **690** for various time segments  $t_1$ ,  $t_2$ ,  $t_3$  **692-696**. The parameter range (PR) **650** is:

$$\text{PR} = \text{Max} - L_2 \quad (3)$$

and the adaptive threshold range (ATR) **660** is:

$$\text{ATR} = L_1 - L_2 \quad (4)$$

As shown in FIG. 6, during a first time period  $t_1$  **692**, a parameter segment **620** has a baseline (B) **622** at about  $\text{Max}$  **612**. As such,  $\Delta$  **626** =  $\text{Max} - L_1$  and the adaptive threshold (AT) **628** is at about  $L_1$  **614**. Accordingly, a transient **624** having a size less than  $\Delta$  **626** does not trigger the alarm **412** (FIG. 4A).

Also shown in FIG. 6, during a second time period  $t_2$  **694**, a parameter segment **630** has a baseline (B) **632** at about  $L_1$  **614**. As such,  $\Delta$  **636** is less than  $\text{Max} - L_1$  and the adaptive threshold (AT) **638** is between  $L_1$  and  $L_2$ . Accordingly, a smaller transient **634** will trigger the alarm as compared to a transient **624** in the first time segment.

Further shown in FIG. 6, during a third time period  $t_3$  **696**, a parameter segment **640** has a baseline (B) **642** at about  $L_2$  **616**. As such,  $\Delta$  **646** is about zero and the adaptive threshold (AT) **648** is at about  $L_2$ . Accordingly, even a small negative transient will trigger the alarm. As such, the behavior of the alarm threshold AT **628**, **638**, **648** advantageously adapts to higher or lower baseline values so as to increase or decrease the size of negative transients that trigger or do not trigger the alarm **412** (FIG. 4A).

FIG. 7 is a parameter versus time graph **700** illustrating the characteristics of an adaptive alarm system **400** (FIGS. 4A-B), as described with respect to FIGS. 4-6, above, where the parameter is oxygen saturation ( $\text{SpO}_2$ ). The graph **700** has a  $\text{SpO}_2$  trace **710** and a superimposed baseline trace **720**. The graph **700** also delineates tracking periods **730**, where the baseline **720** follows the upper portions of  $\text{SpO}_2$  values, and lagging periods **740**, where the baseline **720** does not follow transient  $\text{SpO}_2$  events. The tracking time periods **730** illustrate that the baseline **720** advantageously tracks at the

higher range of  $\text{SpO}_2$  values **710** during relatively stable (flat) periods, as described above. Lagging time periods **740** illustrate that the baseline **720** is advantageously limited in response to transient desaturation events so that significant desaturations fall below an adaptive threshold (not shown) and trigger an alarm accordingly.

FIG. 8 is a parameter versus time graph **800** illustrating characteristics of an adaptive alarm system **400** (FIGS. 4A-B), as described with respect to FIGS. 4-6, above, where the parameter is oxygen saturation ( $\text{SpO}_2$ ). Vertical axis ( $\text{SpO}_2$ ) resolution is 1%. The time interval **801** between vertical hash marks is five minutes. The graph **800** has a  $\text{SpO}_2$  trace **810** and a baseline trace **820**. The graph **800** also has a fixed threshold trace **830**, a first adaptive threshold (AT) trace **840** and a second AT trace **850**. The graph **800** further has a fixed threshold alarm trace **860**, a first adaptive threshold alarm trace **870** and a second adaptive threshold alarm trace **880**. In this example,  $L_1$  is 90% and  $L_2$  is 85% for the first AT trace **840** and first AT alarm trace **870**.  $L_2$  is 80% for a second AT trace **850** and a second AT alarm trace **880**. The fixed threshold **830** results in many nuisance alarms **860**. By comparison, the adaptive threshold alarm with  $L_2 = 85\%$  has just one time interval of alarms **872** during a roughly 6% desaturation period (from 92% to 86%). The adaptive threshold alarm with  $L_2 = 80\%$ , has no alarms during the 1 hour 25 minute monitoring period.

FIGS. 9A-B illustrate an adaptive alarm system **900** embodiment having upper parameter limits  $U_1$  and  $U_2$ . As shown in FIG. 9A, the adaptive alarm system **900** has parameter **901**, first limit ( $U_1$ ) **903**, second limit ( $U_2$ ) **905** and minimum parameter value (Min) **906** inputs and generates a corresponding alarm **912** output. The parameter **901** input is generated by a physiological parameter processor, such as a pulse oximeter or an advanced blood parameter processor described above, as examples. The adaptive alarm system **900** has an alarm generator **910**, a baseline processor **920**, and an adaptive threshold processor **940**. The alarm generator **910** has parameter **901** and adaptive threshold (AT) **942** inputs and generates the alarm **912** output accordingly. A baseline processor **920** has the parameter **901** input and generates a parameter baseline (B) **922** output. The baseline processor **920**, is described in detail with respect to FIG. 9B, below. An adaptive threshold processor **940** has parameter baseline (B) **922**,  $U_1$  **903**,  $U_2$  **905** and Min **906** inputs and generates the adaptive threshold (AT) **942**. The adaptive threshold processor **940** is described in detail with respect to FIGS. 10A-B, below.

As shown in FIG. 9A, in an embodiment  $U_1$  **903** and  $U_2$  **905** may correspond to conventional fixed alarm thresholds with and without an alarm time delay, respectively. For an adaptive threshold schema, however,  $U_1$  **903** and  $U_2$  **905** do not determine an alarm threshold per se, but are reference levels for determining an adaptive threshold (AT) **942**. In an embodiment,  $U_1$  **903** is a lower limit of the adaptive alarm threshold AT when the baseline is near the minimum parameter value (Min), and  $U_2$  **905** is an upper limit of the adaptive alarm threshold, as described in detail with respect to FIGS. 10A-B, below. In an exemplar embodiment when the parameter is oxygen saturation,  $U_1$  **903** is set at or around 85% and  $U_2$  **905** is set at or around 90% oxygen saturation. Many other  $U_1$  and  $U_2$  values may be used for an adaptive threshold schema as described herein.

Also shown in FIG. 9A, in an embodiment the alarm **912** output is triggered when the parameter **901** input rises above AT **942** and ends when the parameter **901** input falls below AT **942** or is otherwise cancelled. In an embodiment, the alarm **912** output is triggered after a time delay (TD), which

may be fixed or variable. In an embodiment, the time delay (TD) is a function of the adaptive threshold (AT) 942. In an embodiment, the time delay (TD) is zero when the adaptive threshold (AT) is at the second upper limit ( $U_2$ ) 905.

As shown in FIG. 9B, a baseline processor 920 embodiment has a sliding window 950, a bias calculator 960, a trend calculator 970 and a response limiter 980. The sliding window 950 inputs the parameter 901 and outputs a time segment 952 of the parameter 901. In an embodiment, each window incorporates a five minute span of parameter values. The bias calculator 960 advantageously provides a downward shift in the baseline (B) 922 for an additional margin of error over missed true alarms. That is, a baseline 922 is generated that tracks a lower-than-average range of parameter values, effectively lowering the adaptive threshold AT slightly below a threshold calculated based upon a true parameter average. In an embodiment, the bias calculator 960 rejects an upper range of parameter values from each time segment 952 from the sliding window so as to generate a biased time segment 962.

Also shown in FIG. 9B, the trend calculator 970 outputs a biased trend 972 of the remaining lower range of parameter values in each biased segment 962. In an embodiment, the biased trend 962 is an average of the values in the biased time segment 962. In other embodiments, the biased trend 962 is a median or mode of the values in the biased time segment 962. The response limiter 980 advantageously limits the extent to which the baseline 922 output tracks the biased trend 972. Accordingly, the baseline 922 tracks only relatively longer-lived transitions of the parameter, but does not track (and hence mask) physiologically significant parameter events, such as oxygen desaturations for a  $SpO_2$  parameter to name but one example. In an embodiment, the response limiter 980 has a low pass transfer function. In an embodiment, the response limiter 980 is a slew rate limiter.

FIGS. 10A-B further illustrate an adaptive threshold processor 940 (FIG. 9A) having a baseline (B) 922 input and generating an adaptive threshold (AT) 942 output and a delta ( $\Delta$ ) 944 ancillary output according to parameter limits  $U_1$  903,  $U_2$  905 and Min 906, as described above. As shown in FIG. 10A, as the baseline (B) 922 decreases (increases) the adaptive threshold (AT) 944 monotonically decreases (increases) between  $U_1$  903 and  $U_2$  905. Further, as the baseline (B) 922 decreases (increases) the delta ( $\Delta$ ) 944 difference between the baseline (B) 922 and the adaptive threshold (AT) 942 monotonically decreases (increases) between Min- $U_1$  and zero.

As shown in FIG. 10B, the relationship between the delta ( $\Delta$ ) 944 and the baseline (B) 944 may be linear 550 (solid line), non-linear 560 (small-dash lines) or piecewise-linear (large-dash lines), to name a few. In an embodiment, the adaptive threshold processor 940 (FIG. 9A) calculates an adaptive threshold (AT) 942 output in response to the baseline (B) 922 input according to a linear relationship. In a linear embodiment, the adaptive threshold processor 940 (FIG. 9A) calculates the adaptive threshold (AT) 942 according to EQS. 5-6:

$$\Delta = -\left(\frac{U_1 - \text{Min}}{U_2 - \text{Min}}\right)(B - \text{Min}) + (U_1 - \text{Min}) \quad (5)$$

$$AT = B + \Delta \quad (6)$$

where  $\Delta = U_1 - \text{Min}$  @  $B = \text{Min}$ ;  $\Delta = 0$  @  $B = U_2$   
and where  $AT = U_1$  @  $B = \text{Min}$ ;  $AT = U_2$  @  $B = U_2$ , accordingly.

FIG. 11 illustrates the operational characteristics an adaptive alarm system 900 (FIG. 9A) having parameter limits Min 1112,  $U_1$  1114 and  $U_2$  1116 and an alarm responsive to a baseline (B) 1122, 1132, 1142; an adaptive threshold (AT) 1128, 1138, 1148; and a corresponding  $\Delta$  1126, 1136, 1146 according to EQS. 5-6, above. In particular, a physiological parameter 1110 is graphed versus time 1190 for various time segments  $t_1$ ,  $t_2$ ,  $t_3$  1192-1196. The parameter range (PR) 1150 is:

$$PR = U_2 - \text{Min} \quad (7)$$

and the adaptive threshold range (ATR) 1160 is:

$$ATR = U_2 - U_1 \quad (8)$$

As shown in FIG. 11, during a first time period  $t_1$  1192, a parameter segment 1120 has a baseline (B) 1122 at about Min 1112. As such,  $\Delta$  1126 =  $U_1 - \text{Min}$  and the adaptive threshold (AT) 1128 is at about  $U_1$  1114. Accordingly, a transient 1124 having a size less than  $\Delta$  1126 does not trigger the alarm 912 (FIG. 9A).

Also shown in FIG. 11, during a second time period  $t_2$  1194, a parameter segment 1130 has a baseline (B) 1132 at about  $U_1$  1114. As such,  $\Delta$  1136 is less than  $U_1 - \text{Min}$  and the adaptive threshold (AT) 1138 is between  $U_1$  and  $U_2$ . Accordingly, a smaller transient 1134 will trigger the alarm as compared to a transient 1124 in the first time segment.

Further shown in FIG. 11, during a third time period  $t_3$  1196, a parameter segment 1140 has a baseline (B) 1142 at about  $U_2$  1116. As such,  $\Delta$  1146 is about zero and the adaptive threshold (AT) 1148 is at about  $U_2$ . Accordingly, even a small positive transient will trigger the alarm. As such, the behavior of the alarm threshold AT 1128, 1138, 1148 advantageously adapts to higher or lower baseline values so as to increase or decrease the size of positive transients that trigger or do not trigger the alarm 912 (FIG. 9A).

FIGS. 12A-B illustrate an adaptive alarm system 1200 embodiment having lower limits  $L_1$ ,  $L_2$  1203, such as described with respect to FIGS. 4A-B above, or upper limits  $U_1$ ,  $U_2$  1205 such as described with respect to FIGS. 9A-B above, or both. As shown in FIG. 12A, the adaptive alarm system 1200 has parameter 1201, lower limit 1203 and upper limit 1205 inputs and generates a corresponding alarm 1212 output. The parameter 1201 input is generated by a physiological parameter processor, such as a pulse oximeter or an advanced blood parameter processor described above, as examples. The adaptive alarm system 1200 has an alarm generator 1210, a baseline processor 1220 and an adaptive threshold processor 1240. The alarm generator 1210 has parameter 1201 and adaptive threshold (AT) 1242 inputs and generates the alarm 1212 output accordingly. A baseline processor 1220 has the parameter 1201 input and generates one or more parameter baseline 1222 outputs. The baseline processor 1220, is described in detail with respect to FIG. 12B, below. An adaptive threshold processor 1240 has parameter baseline 1222, lower limit  $L_1$ ,  $L_2$  1203 and upper limit  $U_1$ ,  $U_2$  1205 inputs and generates lower and upper adaptive threshold  $AT_L$ ,  $AT_U$  1242 outputs. The adaptive threshold processor 1240 also generates ancillary upper and lower delta 1244 outputs. The adaptive threshold processor 1240 is described in detail with respect to FIGS. 13A-E, below.

As shown in FIG. 12A, in an embodiment  $L_1$ ,  $L_2$  1203 and  $U_1$ ,  $U_2$  1205 may correspond to conventional fixed alarm thresholds with an alarm delay ( $L_1$ ,  $U_1$ ) and without an alarm delay ( $L_2$ ,  $U_2$ ). For an adaptive threshold schema, however, these limits 1203, 1205 do not determine an alarm

threshold per se, but are reference levels for determining lower and upper adaptive thresholds  $AT_l$ ,  $AT_u$  1242.

Also shown in FIG. 12A, in an embodiment the alarm 1212 output is triggered when the parameter 1201 input falls below  $AT_l$  1242 and ends when the parameter 1201 input rises above  $AT_l$  1242 or the alarm is otherwise cancelled. Further, the alarm 1212 output is triggered when the parameter 1201 input rises above  $AT_u$  1242 and ends when the parameter 1201 input falls below  $AT_u$  1242 or the alarm is otherwise cancelled. In an embodiment, the alarm 1212 output is triggered after a time delay (TD), which may be fixed or variable. In an embodiment, the time delay (TD) is a function of the adaptive thresholds ( $AT_l$ ,  $AT_u$ ) 1242. In an embodiment, the time delay (TD) is zero when the lower adaptive threshold ( $AT_l$ ) 1242 is at the second lower limit ( $L_2$ ) 1203 or when the upper adaptive alarm threshold  $AT_u$  1242 is at the second upper limit ( $U_2$ ) 1205.

As shown in FIG. 12B, a baseline processor 1220 embodiment has a sliding window 1250, an over-bias calculator 1260, an under-bias calculator 1265, trend calculators 1270 and response limiters 1280. The sliding window 1250 inputs the parameter 1201 and outputs a time segment 1252 of the parameter 1201. In an embodiment, each window incorporates a five minute span of parameter 1201 values.

Also shown in FIG. 12B, the over-bias calculator 1260 advantageously provides an upward shift in the lower baseline ( $B_l$ ) 1282 for an additional margin of error over missed lower true alarms. That is, a lower baseline ( $B_l$ ) 1282 is generated that tracks a higher-than-average range of parameter values, effectively raising the lower adaptive threshold  $AT_l$  slightly above a threshold calculated based upon a true parameter average. In an embodiment, the over-bias calculator 1260 rejects a lower range of parameter values from each time segment 1252 of the sliding window 1250 so as to generate an over-biased time segment 1262.

Further shown in FIG. 12B, the under-bias calculator 1265 advantageously provides a downward shift in the upper baseline ( $B_u$ ) 1287 for an additional margin of error over missed upper true alarms. That is, an upper baseline ( $B_u$ ) 1287 is generated that tracks a lower-than-average range of parameter values, effectively lowering the upper adaptive threshold  $AT_u$  slightly below a threshold calculated based upon a true parameter average. In an embodiment, the under-bias calculator 1267 rejects an upper range of parameter values from each time segment 1252 of the sliding window 1250 so as to generate an under-biased time segment 1267.

Additionally shown in FIG. 12B, the trend calculator 1270 outputs an over-biased trend 1272 of the remaining higher range of parameter values in each over-biased segment 1262. Further, the trend calculator 1270 outputs an under-biased trend 1277 of the remaining lower range of parameter values in each under-biased segment 1267. In an embodiment, the biased trends 1272, 1277 are each an average of the values in the corresponding biased time segments 1262, 1267. In other embodiments, the biased trends 1272, 1277 are each a median or mode of the values in the corresponding biased time segments 1262, 1267. The response limiter 1280 advantageously limits the extent to which the baseline 1222 outputs track the biased trends 1272, 1277. Accordingly, the baseline 1222 outputs track only relatively longer-lived transitions of the parameter 1201, but do not track (and hence mask) physiologically significant parameter events. In an embodiment, the response limiter 1280 has a low pass transfer function. In an embodiment, the response limiter 1280 is a slew rate limiter.

FIGS. 13A-E illustrate parameter (P) operating ranges and ideal ranges in view of both lower and upper parameter limits. As shown in FIG. 13A, as the baseline ( $B_l$ ) 1317 decreases (increases) the adaptive threshold ( $AT_l$ ) 1318 monotonically decreases (increases) between  $L_1$  and  $L_2$ . Further, as the baseline ( $B_l$ ) 1317 decreases (increases) the delta ( $\Delta_l$ ) 1319 difference between the baseline ( $B_l$ ) 1317 and the adaptive threshold ( $AT_l$ ) 1318 monotonically decreases (increases) between  $Max-L_1$  and 0.

As shown in FIG. 13B, as the baseline ( $B_u$ ) 1327 increases (decreases) the adaptive threshold ( $AT_u$ ) 1328 monotonically increases (decreases) between  $U_1$  and  $U_2$ . Further, as the baseline ( $B_u$ ) 1327 increases (decreases) the delta ( $\Delta_u$ ) 1329 difference between the adaptive threshold ( $AT_u$ ) 1328 and the baseline ( $B_u$ ) 1327 monotonically decreases (increases) between  $Min-U_1$  and 0.

As shown in FIG. 13C, combining FIGS. 13A-B, the parameter (P) operating range is bounded by the overlapping regions of 13A and 13B 1330 having an upper bound of  $U_2$  and a lower bound of  $L_2$ . In particular,  $L_1$ ,  $L_2$  are the upper and lower limits of the lower adaptive alarm threshold  $AT_l$ ; and  $U_2$ ,  $U_1$  are the upper and lower limits of the upper adaptive alarm threshold  $AT_u$ .

FIG. 13D illustrates parameter (P) versus the overlapping independent delta domains  $F_u$ ,  $F_l$  for upper and lower baselines  $B_u$ ,  $B_l$ ; adaptive thresholds  $AT_u$ ,  $AT_l$  and deltas  $\Delta_u$ ,  $\Delta_l$ , based upon FIGS. 13A-C. FIG. 13E illustrates parameter (P) versus the overlapping independent delta domains  $F_u$ ,  $F_l$  (reversed); for upper and lower baselines  $B_u$ ,  $B_l$ ; adaptive thresholds  $AT_u$ ,  $AT_l$  and deltas  $\Delta_u$ ,  $\Delta_l$ .

As shown in FIG. 13E, the equations for bi-lateral adaptive thresholds are:

$$\Delta_u = -\left(\frac{U_1 - L_2}{U_2 - L_2}\right)(B - L_2) + (U_1 - L_2) \quad (9)$$

$$AT_u = B + \Delta_u \quad (10)$$

where  $\Delta_u = U_1 - L_2$  @  $B = L_2$ ; and  $\Delta_u = 0$  @  $B = U_2$ ; and where  $AT_u = L_1$  @  $B = L_2$ ; and  $AT_u = U_2$  @  $B = U_2$ . Further:

$$\Delta_l = \left(\frac{U_2 - L_1}{U_2 - L_2}\right)(B - L_2) \quad (11)$$

$$AT_l = B - \Delta_l \quad (12)$$

where  $\Delta_l = U_2 - L_1$  @  $B = U_2$ ; and  $\Delta_l = 0$  @  $B = L_2$ ; and where  $AT_l = L_1$  @  $B = U_2$ ;  $AT_l = L_2$  @  $B = L_2$ .

Although shown as a linear relationship, in general:

$$\Delta_l = f_1(B); \Delta_u = f_2(B)$$

That is,  $\Delta_l$  and  $\Delta_u$  can each be a linear function of B, a non-linear function of B or a piecewise linear function of B, to name a few, in a manner similar to that described with respect to FIGS. 5B and 10B, above.

FIGS. 14A-B illustrate the operational characteristics an adaptive alarm system 1200 (FIGS. 12A-B) having upper limits  $U_1$ ,  $U_2$  1412, 1414 and lower limits  $L_1$ ,  $L_2$  1422, 1424. An alarm 1212 (FIG. 12A) output is responsive to a baseline (B) 1432, 1442, 1452, 1462; an upper delta ( $\Delta_u$ ) 1437, 1447, 1457, 1467; and a corresponding upper adaptive threshold ( $AT_u$ ) 1439, 1449, 1459, 1469, according to EQS. 9-10, above. Further, the alarm 1212 (FIG. 12A) output is responsive to a lower delta ( $\Delta_l$ ) 1436, 1446, 1456, 1466 and a

corresponding lower adaptive threshold ( $AT_l$ ) **1438**, **1448**, **1458**, **1468**, according to EQS. 11-12, above.

As shown in FIGS. **14A-B**, a physiological parameter **1410** is graphed versus time **1490** for various time segments  $t_1$ ,  $t_2$ ,  $t_3$ ,  $t_4$  **1492-1498**. The parameter range (PR) **1480** is:

$$PR=U_2-L_2 \quad (13)$$

the lower adaptive threshold  $AT_l$  range is:

$$ATR_l=L_1-L_2 \quad (14)$$

the upper adaptive threshold  $AT_u$  range is:

$$ATR_u=U_2-U_1 \quad (15)$$

As shown in FIG. **14A**, during a first time period  $t_1$  **1492**, a parameter segment **1430** has a baseline (B) **1432** at about  $U_2$  **1414**. As such,  $\Delta_l$  **1436**= $U_2-L_1$ ;  $\Delta_u$  **1437**=0;  $AT_l$  **1438**= $L_1$ ;  $AT_u$  **1439**= $U_2$ . Accordingly, a negative transient **1434** having a size less than  $U_2-L_1$  does not trigger an alarm.

Also shown in FIG. **14A**, during a second time period  $t_2$  **1494**, a parameter segment **1440** has a baseline (B) **1442** less than  $U_2$ . As such,  $\Delta_l$  **1446** is less than  $U_1-L_1$  and the adaptive threshold ( $AT_l$ ) **1447** is between  $U_1$  and  $U_2$ . Accordingly, a smaller negative transient **1444** will trigger the alarm as compared to the negative transient **1434** in the first time segment **1430**.

Further shown in FIG. **14A**, during a third time period  $t_3$  **1496**, a parameter segment **1450** has a baseline (B) **1452** less than  $U_1$  **1412**. As such, a smaller negative transient **1454** will trigger the alarm as compared to the negative transient **1444** in the second time segment **1440**. However, a larger positive transient **1455** is needed to trigger the alarm as compared to the positive transient **1445** in the second time segment **1440**.

Additionally shown in FIG. **14A**, during a fourth time period  $t_4$  **1460**, a parameter segment **1460** has a baseline (B) **1462** at about  $L_2$  **1424**. As such,  $\Delta_l$  **1466**=0;  $\Delta_u$  **1467**= $U_1-L_2$ ;  $AT_l$  **1468**= $L_2$ ;  $AT_u$  **1469**= $U_1$ . Accordingly, a positive transient **1465** having a size less than  $U_1-L_2$  does not trigger an alarm.

An adaptive alarm system has been disclosed in detail in connection with various embodiments. These embodiments are disclosed by way of examples only and are not to limit the scope of the claims that follow. One of ordinary skill in the art will appreciate many variations and modifications.

What is claimed is:

**1.** An improved method of obtaining pulse oximetry measurements and reducing false alarms therefrom, the method comprising:

continuously measuring, with a pulse oximeter in communication with an optical sensor, a physiological parameter over a first time window;

establishing, with the pulse oximeter, a baseline for the physiological parameter, the parameter baseline being determined from values of the physiological parameter taken during a second window of time within the first time window, the baseline is reestablished using a new window of data on a continuing basis over the first time window;

automatically determining, with the pulse oximeter, an upper alarm threshold and a lower alarm threshold at a delta difference from a most recent value of the baseline, the delta difference for the upper alarm threshold increases when the baseline drifts away from a maximum parameter limit and decreases when the baseline drifts toward the maximum parameter limit, the delta difference for the lower alarm threshold increases when

the baseline drifts away from a minimum parameter limit and decreases when the baseline drifts toward the minimum parameter limit;

dynamically adjusting, with the pulse oximeter, at predetermined regular intervals the delta difference between the alarm thresholds and the baseline during the first time window, the delta difference is adjusted based on a current value of the baseline, and the alarm thresholds are re-determined at the predetermined regular intervals over the first time window using the current delta difference; and

triggering an alarm in response to the parameter measurement crossing either of the alarm thresholds.

**2.** The method according to claim **1** wherein establishing a baseline comprises:

biasing a segment of the parameter measurement; determining a biased trend from the biased segment; and restricting a transient response of the biased trend.

**3.** The method according to claim **1** wherein adjusting the delta difference comprises:

setting a parameter limit; and determining the delta difference between the alarm thresholds and the baseline as a linear function of the baseline according to the parameter limit.

**4.** The method according to claim **1**, further comprising setting a parameter limit which includes:

selecting a first parameter limit in relation to a delayed alarm; and

selecting a second parameter limit in relation to an un-delayed alarm.

**5.** The method according to claim **2** wherein biasing a segment of the parameter comprises:

windowing the parameter measurements; removing a lower value portion of the windowed parameter measurements; and averaging a remaining portion of the windowed parameter measurements.

**6.** An improved pulse oximeter with reduced false alarms comprising:

an input configured to receive one or more signals from an optical sensor, the optical sensor measuring a change in light absorption of a patient's tissue; and

at least one hardware processor, the hardware processor configured to determine a plurality of physiological parameter values over a span of time and determines a baseline according to a trend of the parameter values, the baseline is re-determined at predetermined regular intervals, the predetermined regular intervals occur when a new plurality of physiological parameter values are determined;

the at least one hardware processor further configured to establishing an upper and lower alarm threshold at a delta difference from the baseline at each predetermined regular interval, the delta difference of the upper alarm threshold increasing when the baseline drifts away from a maximum parameter limit and decreasing when the baseline drifts toward the maximum parameter limit, the delta difference of the lower alarm threshold increasing when the baseline drifts away from a minimum parameter limit and decreasing when the baseline drifts toward the minimum parameter limit; and

an alarm generator, the alarm generator is configured to trigger an alarm when a parameter transient from the baseline crosses the upper or lower alarm thresholds.

7. The improved pulse oximeter according to claim 6 wherein the at least one hardware processor is further configured to outputs a biased trend; and

the baseline responsive to the biased trend to reduce the size of a transient that triggers the alarm. 5

8. The improved pulse oximeter according to claim 7 wherein the at least one hardware processor is further configured to reduces baseline movement due to parameter transients.

9. The improved pulse oximeter according to claim 6 10 wherein the alarm generator is responsive to both positive and negative transients from the baseline.

10. The improved pulse oximeter according to claim 9 wherein the at least one hardware processor is further configured to establishes a lower baseline biased above the 15 parameter trend and an upper baseline biased below the parameter trend.

11. The improved pulse oximeter according to claim 10 wherein the lower alarm threshold is increasingly responsive to negative transients and the upper alarm threshold is 20 decreasingly responsive to positive transients as the baseline trends toward lower parameter values.

\* \* \* \* \*

专利名称(译)	自适应报警系统		
公开(公告)号	<a href="#">US9724024</a>	公开(公告)日	2017-08-08
申请号	US13/037184	申请日	2011-02-28
[标]申请(专利权)人(译)	梅西莫股份有限公司		
申请(专利权)人(译)	Masimo公司		
当前申请(专利权)人(译)	Masimo公司		
[标]发明人	AL ALI AMMAR		
发明人	AL-ALI, AMMAR		
IPC分类号	A61B5/1455 G08B29/26 A61B5/00		
CPC分类号	A61B5/14551 A61B5/746 G08B29/26 A61B2560/0276 A61B5/1455 A61B5/14552 A61B5/74		
优先权	61/309419 2010-03-01 US 61/328630 2010-04-27 US		
其他公开文献	US20110213212A1		
外部链接	<a href="#">Espacenet</a> <a href="#">USPTO</a>		

摘要(译)

自适应报警系统响应于生理参数，以便产生警报阈值，该警报阈值适应参数中的基线漂移并且减少错误警报而没有错过的真实警报的相应增加。自适应报警系统具有从使用与生物通信的传感器的生理测量系统导出的参数。基线处理器根据参数趋势计算参数基线。参数限制指定参数的允许范围。自适应阈值处理器根据参数基线和参数限制计算自适应阈值。警报发生器响应于参数和自适应阈值，以便触发指示参数越过自适应阈值的警报。自适应阈值响应于参数基线，以便随着参数基线漂移到较高参数值而增加值，并随着参数基线漂移到较低参数值而减小值。

