



US008965473B2

(12) **United States Patent**
Hoarau et al.

(10) **Patent No.:** **US 8,965,473 B2**
(45) **Date of Patent:** **Feb. 24, 2015**

(54) **MEDICAL SENSOR FOR REDUCING MOTION ARTIFACTS AND TECHNIQUE FOR USING THE SAME**

(75) Inventors: **Carine Hoarau**, Lafayette, CA (US);
Clark R. Baker, Jr., Castro Valley, CA (US);
Edward Karst, South Pasadena, CA (US)

(73) Assignee: **Covidien LP**, Mansfield, MA (US)

(*) Notice: Subject to any disclaimer, the term of this patent is extended or adjusted under 35 U.S.C. 154(b) by 702 days.

(21) Appl. No.: **13/267,681**

(22) Filed: **Oct. 6, 2011**

(65) **Prior Publication Data**

US 2012/0035443 A1 Feb. 9, 2012

Related U.S. Application Data

(63) Continuation of application No. 11/497,089, filed on Aug. 1, 2006, now Pat. No. 8,060,171, which is a continuation of application No. 11/241,375, filed on Sep. 29, 2005, now Pat. No. 7,869,850.

(51) **Int. Cl.**
A61B 5/1455 (2006.01)
A61B 5/00 (2006.01)

(52) **U.S. Cl.**
CPC **A61B 5/6886** (2013.01); **A61B 5/14552** (2013.01); **A61B 5/6826** (2013.01); **A61B 5/6838** (2013.01); **A61B 5/6844** (2013.01)
USPC **600/323**; 600/344

(58) **Field of Classification Search**
CPC A61B 5/1455; A61B 5/14551; A61B 5/14552; A61B 5/6826; A61B 5/6832; A61B 5/6886; A61B 2562/0233
USPC 600/310, 322, 323, 344
See application file for complete search history.

(56) **References Cited**

U.S. PATENT DOCUMENTS

3,403,555 A 10/1968 Versaci et al.
3,536,545 A 10/1970 Traynor et al.
D222,454 S 10/1971 Beeber

(Continued)

FOREIGN PATENT DOCUMENTS

CN 11080192 11/2007
DE 3405444 8/1985

(Continued)

OTHER PUBLICATIONS

Yamazaki, Nakaji, et al.; "Motion Artifact Resistant Pulse Oximeter (Durapulse PA 2100)," *Journal of Oral Cavity Medicine*, vol. 69, No. 4, pp. 53 (1980) (Article in Japanese—contains English summary of article).

(Continued)

Primary Examiner — Eric Winakur

(74) *Attorney, Agent, or Firm* — Fletcher Yoder PC

(57) **ABSTRACT**

A sensor for pulse oximetry or other applications utilizing spectrophotometry may be adapted to reduce motion artifacts by fixing the optical distance between an emitter and detector. A flexible sensor is provided with a stiffening member to hold the emitter and detector of the sensor in a relatively fixed position when applied to a patient. Further, an annular or partially annular sensor is adapted to hold an emitter and detector of the sensor in a relatively fixed position when applied to a patient. A clip-style sensor is provided with a spacer that controls the distance between the emitter and detector.

20 Claims, 8 Drawing Sheets

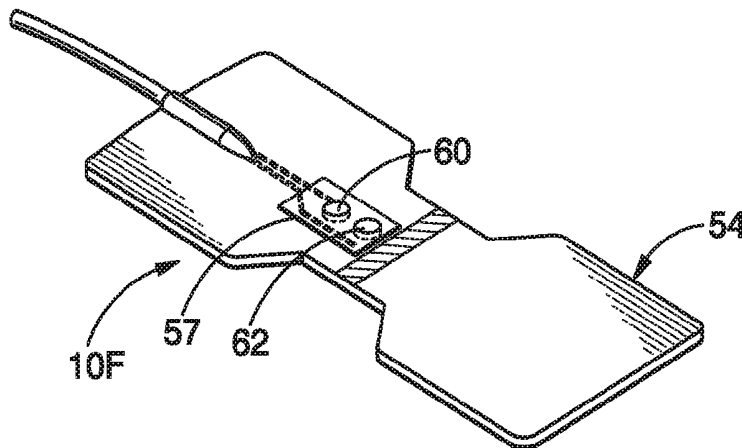

(56)

References Cited

U.S. PATENT DOCUMENTS

3,721,813 A	3/1973	Condon et al.	4,971,062 A	11/1990	Hasebe et al.
4,098,772 A	7/1978	Bonk et al.	4,974,591 A	12/1990	Awazu et al.
D250,275 S	11/1978	Bond	5,007,423 A	4/1991	Branstetter et al.
D251,387 S	3/1979	Ramsay et al.	5,025,791 A	6/1991	Niwa
D262,488 S	12/1981	Rossman et al.	RE33,643 E	7/1991	Isaacson et al.
4,321,930 A	3/1982	Jobsis et al.	5,028,787 A	7/1991	Rosenthal et al.
4,334,544 A	6/1982	Hill et al.	5,035,243 A	7/1991	Muz
4,350,165 A	9/1982	Striese	5,040,539 A	8/1991	Schmitt et al.
4,353,372 A	10/1982	Ayer	5,041,187 A	8/1991	Hink et al.
4,380,240 A	4/1983	Jobsis et al.	5,054,488 A	10/1991	Muz
4,406,289 A	9/1983	Wesseling et al.	5,055,671 A	10/1991	Jones
4,510,551 A	4/1985	Brainard, II	5,058,588 A	10/1991	Kaestle
4,510,938 A	4/1985	Jobsis et al.	5,065,749 A	11/1991	Hasebe et al.
4,586,513 A	5/1986	Hamaguri	5,066,859 A	11/1991	Karkar et al.
4,603,700 A	8/1986	Nichols et al.	5,069,213 A	12/1991	Polczynski
4,621,643 A	11/1986	New, Jr. et al.	5,078,136 A	1/1992	Stone et al.
4,653,498 A	3/1987	New, Jr. et al.	5,086,229 A	2/1992	Rosenthal et al.
4,677,528 A	6/1987	Miniet	5,088,493 A	2/1992	Giannini et al.
4,685,464 A	8/1987	Goldberger et al.	5,090,410 A	2/1992	Saper et al.
4,694,833 A	9/1987	Hamaguri	5,094,239 A	3/1992	Jaeb et al.
4,697,593 A	10/1987	Evans et al.	5,094,240 A	3/1992	Muz
4,700,708 A	10/1987	New, Jr. et al.	5,099,841 A	3/1992	Heinonen et al.
4,714,080 A	12/1987	Edgar, Jr. et al.	5,099,842 A	3/1992	Mannheimer et al.
4,714,341 A	12/1987	Hamaguri et al.	H1039 H	4/1992	Tripp et al.
4,722,120 A	2/1988	Lu	5,104,623 A	4/1992	Miller
4,726,382 A	2/1988	Boehmer et al.	5,109,849 A	5/1992	Goodman et al.
4,759,369 A	7/1988	Taylor	5,111,817 A	5/1992	Clark et al.
4,770,179 A	9/1988	New, Jr. et al.	5,113,861 A	5/1992	Rother
4,773,422 A	9/1988	Isaacson et al.	D326,715 S	6/1992	Schmidt
4,776,339 A	10/1988	Schreiber	5,125,403 A	6/1992	Culp
4,781,195 A	11/1988	Martin	5,127,406 A	7/1992	Yamaguchi
4,783,815 A	11/1988	Buttner	5,131,391 A	7/1992	Sakai et al.
4,796,636 A	1/1989	Branstetter et al.	5,140,989 A	8/1992	Lewis et al.
4,800,495 A	1/1989	Smith	5,152,296 A	10/1992	Simons
4,800,885 A	1/1989	Johnson	5,154,175 A	10/1992	Gunther
4,802,486 A	2/1989	Goodman et al.	5,158,082 A	10/1992	Jones
4,805,623 A	2/1989	Jöbssis	5,170,786 A	12/1992	Thomas et al.
4,807,630 A	2/1989	Malinouskas	5,188,108 A	2/1993	Secker et al.
4,807,631 A	2/1989	Hersh et al.	5,190,038 A	3/1993	Polson et al.
4,819,646 A	4/1989	Cheung et al.	5,193,542 A	3/1993	Missanelli et al.
4,819,752 A	4/1989	Zelin	5,193,543 A	3/1993	Yelderman
4,824,242 A	4/1989	Frick et al.	5,203,329 A	4/1993	Takatani et al.
4,825,872 A	5/1989	Tan et al.	5,209,230 A	5/1993	Swedlow et al.
4,825,879 A	5/1989	Tan et al.	5,213,099 A	5/1993	Tripp et al.
4,830,014 A	5/1989	Goodman et al.	5,216,598 A	6/1993	Branstetter et al.
4,832,484 A	5/1989	Aoyagi et al.	5,217,012 A	6/1993	Young et al.
4,846,183 A	7/1989	Martin	5,217,013 A	6/1993	Lewis et al.
4,848,901 A	7/1989	Hood, Jr.	5,218,207 A	6/1993	Rosenthal
4,854,699 A	8/1989	Edgar, Jr.	5,218,962 A	6/1993	Mannheimer et al.
4,859,056 A	8/1989	Prosser et al.	5,224,478 A	7/1993	Sakai et al.
4,859,057 A	8/1989	Taylor et al.	5,226,417 A	7/1993	Swedlow et al.
4,863,265 A	9/1989	Flower et al.	5,228,440 A	7/1993	Chung et al.
4,865,038 A	9/1989	Rich et al.	5,237,994 A	8/1993	Goldberger
4,867,557 A	9/1989	Takatani et al.	5,239,185 A	8/1993	Ito et al.
4,869,253 A	9/1989	Craig, Jr. et al.	5,246,002 A	9/1993	Prosser
4,869,254 A	9/1989	Stone et al.	5,246,003 A	9/1993	DeLonzor
4,880,304 A	11/1989	Jaeb et al.	5,247,931 A	9/1993	Norwood
4,883,055 A	11/1989	Merrick	5,247,932 A	9/1993	Chung et al.
4,883,353 A	11/1989	Hansmann et al.	5,249,576 A	10/1993	Goldberger et al.
4,890,619 A	1/1990	Hatschek	5,253,645 A	10/1993	Friedman et al.
4,892,101 A	1/1990	Cheung et al.	5,253,646 A	10/1993	Delpy et al.
4,901,238 A	2/1990	Suzuki et al.	5,259,381 A	11/1993	Cheung et al.
4,908,762 A	3/1990	Suzuki et al.	5,259,761 A	11/1993	Schnettler et al.
4,911,167 A	3/1990	Corenman et al.	5,263,244 A	11/1993	Centa et al.
4,913,150 A	4/1990	Cheung et al.	5,267,562 A	12/1993	Ukawa et al.
4,926,867 A	5/1990	Kanda et al.	5,267,563 A	12/1993	Swedlow et al.
4,927,264 A	5/1990	Shiga et al.	5,267,566 A	12/1993	Choucair et al.
4,928,692 A	5/1990	Goodman et al.	5,273,036 A	12/1993	Kronberg et al.
4,934,372 A	6/1990	Corenman et al.	5,275,159 A	1/1994	Griebel
4,938,218 A	7/1990	Goodman et al.	5,278,627 A	1/1994	Aoyagi et al.
4,942,877 A	7/1990	Sakai et al.	5,279,295 A	1/1994	Martens et al.
4,948,248 A	8/1990	Lehman	5,285,783 A	2/1994	Secker
4,955,379 A	9/1990	Hall	5,285,784 A	2/1994	Seeker
4,960,126 A	10/1990	Conlon et al.	5,287,853 A	2/1994	Vester et al.
4,964,408 A	10/1990	Hink et al.	5,291,884 A	3/1994	Heinemann et al.
			5,297,548 A	3/1994	Pologe
			5,299,120 A	3/1994	Kaestle
			5,299,570 A	4/1994	Hatschek
			5,309,908 A	5/1994	Friedman et al.

(56)

References Cited

U.S. PATENT DOCUMENTS

5,311,865	A	5/1994	Mayeux	5,551,423	A	9/1996	Sugiura
5,313,940	A	5/1994	Fuse et al.	5,551,424	A	9/1996	Morrison et al.
5,323,776	A	6/1994	Blakeley et al.	5,553,614	A	9/1996	Chance
5,329,922	A	7/1994	Atlee, III	5,553,615	A	9/1996	Carim et al.
5,337,744	A	8/1994	Branigan	5,555,882	A	9/1996	Richardson et al.
5,339,810	A	8/1994	Ivers et al.	5,558,096	A	9/1996	Palatnik
5,343,818	A	9/1994	McCarthy et al.	5,560,355	A	10/1996	Merchant et al.
5,343,869	A	9/1994	Pross et al.	5,564,417	A	10/1996	Chance
5,348,003	A	9/1994	Caro	5,575,284	A	11/1996	Athan et al.
5,348,004	A	9/1994	Hollub et al.	5,575,285	A	11/1996	Takanashi et al.
5,348,005	A	9/1994	Merrick et al.	5,577,500	A	11/1996	Potratz
5,349,519	A	9/1994	Kaestle	5,582,169	A	12/1996	Oda et al.
5,349,952	A	9/1994	McCarthy et al.	5,584,296	A	12/1996	Cui et al.
5,349,953	A	9/1994	McCarthy et al.	5,588,425	A	12/1996	Sackner et al.
5,351,685	A	10/1994	Potratz	5,588,427	A	12/1996	Tien
5,353,799	A	10/1994	Chance	5,590,652	A	1/1997	Inai
5,355,880	A	10/1994	Thomas et al.	5,595,176	A	1/1997	Yamaura
5,355,882	A	10/1994	Ukawa et al.	5,596,986	A	1/1997	Goldfarb
5,361,758	A	11/1994	Hall et al.	5,611,337	A	3/1997	Bukta
5,365,066	A	11/1994	Krueger, Jr. et al.	5,617,852	A	4/1997	MacGregor
5,368,025	A	11/1994	Young et al.	5,619,991	A	4/1997	Sloane
5,368,026	A	11/1994	Swedlow et al.	5,619,992	A	4/1997	Guthrie et al.
5,368,224	A	11/1994	Richardson et al.	5,626,140	A	5/1997	Feldman et al.
5,372,136	A	12/1994	Steuer et al.	5,629,992	A	5/1997	Amersfoort et al.
5,377,675	A	1/1995	Ruskewicz et al.	5,630,413	A	5/1997	Thomas et al.
5,385,143	A	1/1995	Aoyagi	5,632,272	A	5/1997	Diab et al.
5,387,122	A	2/1995	Goldberger et al.	5,632,273	A	5/1997	Suzuki
5,390,670	A	2/1995	Centa et al.	5,634,459	A	6/1997	Gardosi
5,392,777	A	2/1995	Swedlow et al.	5,638,593	A	6/1997	Gerhardt et al.
5,398,680	A	3/1995	Polson et al.	5,638,816	A	6/1997	Kiani-Azarbayjany et al.
5,402,777	A	4/1995	Warring et al.	5,638,818	A	6/1997	Diab et al.
5,402,779	A	4/1995	Chen et al.	5,645,060	A	7/1997	Yorkey
5,411,023	A	5/1995	Morris, Sr. et al.	5,645,440	A	7/1997	Tobler et al.
5,411,024	A	5/1995	Thomas et al.	5,660,567	A	8/1997	Nierlich et al.
5,413,099	A	5/1995	Schmidt et al.	5,662,105	A	9/1997	Tien
5,413,100	A	5/1995	Barthelemy et al.	5,662,106	A	9/1997	Swedlow et al.
5,413,101	A	5/1995	Sugiura	5,664,270	A	9/1997	Bell et al.
5,413,102	A	5/1995	Schmidt et al.	5,666,952	A	9/1997	Fuse et al.
5,417,207	A	5/1995	Young et al.	5,671,529	A	9/1997	Nelson
5,421,329	A	6/1995	Casciani et al.	5,673,692	A	10/1997	Schulze et al.
5,425,360	A	6/1995	Nelson	5,673,693	A	10/1997	Solenberger
5,425,362	A	6/1995	Siker et al.	5,676,139	A	10/1997	Goldberger et al.
5,427,093	A	6/1995	Ogawa et al.	5,676,141	A	10/1997	Hollub
5,429,128	A	7/1995	Cadell et al.	5,678,544	A	10/1997	DeLonzor et al.
5,429,129	A	7/1995	Lovejoy et al.	5,680,857	A	10/1997	Pelikan et al.
5,431,159	A	7/1995	Baker et al.	5,685,299	A	11/1997	Diab et al.
5,431,170	A	7/1995	Mathews	5,685,301	A	11/1997	Klomhaus
5,437,275	A	8/1995	Amundsen et al.	5,687,719	A	11/1997	Sato et al.
5,438,986	A	8/1995	Disch et al.	5,687,722	A	11/1997	Tien et al.
5,448,991	A	9/1995	Polson et al.	5,692,503	A	12/1997	Kuenstner
5,452,717	A	9/1995	Branigan et al.	5,692,505	A	12/1997	Fouts
5,465,714	A	11/1995	Scheuing	5,709,205	A	1/1998	Bukta
5,469,845	A	11/1995	DeLonzor et al.	5,713,355	A	2/1998	Richardson et al.
RE35,122	E	12/1995	Corenman et al.	5,724,967	A	3/1998	Venkatachalam
5,482,034	A	1/1996	Lewis et al.	5,727,547	A	3/1998	Levinson et al.
5,482,036	A	1/1996	Diab et al.	5,730,124	A	3/1998	Yamauchi
5,485,847	A	1/1996	Baker, Jr.	5,731,582	A	3/1998	West
5,490,505	A	2/1996	Diab et al.	D393,830	S	4/1998	Tobler et al.
5,490,523	A	2/1996	Isaacson et al.	5,743,260	A	4/1998	Chung et al.
5,491,299	A	2/1996	Naylor et al.	5,743,262	A	4/1998	Lepper, Jr. et al.
5,494,032	A	2/1996	Robinson et al.	5,743,263	A	4/1998	Baker, Jr.
5,494,043	A	2/1996	O'Sullivan et al.	5,746,206	A	5/1998	Mannheimer
5,497,771	A	3/1996	Rosenheimer	5,746,697	A	5/1998	Swedlow et al.
5,499,627	A	3/1996	Steuer et al.	5,752,914	A	5/1998	DeLonzor et al.
5,503,148	A	4/1996	Pologe et al.	5,755,226	A	5/1998	Carim et al.
5,505,199	A	4/1996	Kim	5,758,644	A	6/1998	Diab et al.
5,507,286	A	4/1996	Solenberger	5,760,910	A	6/1998	Lepper, Jr. et al.
5,511,546	A	4/1996	Hon	5,766,125	A	6/1998	Aoyagi et al.
5,517,988	A	5/1996	Gerhard	5,766,127	A	6/1998	Pologe et al.
5,520,177	A	5/1996	Ogawa et al.	5,769,785	A	6/1998	Diab et al.
5,521,851	A	5/1996	Wei et al.	5,772,587	A	6/1998	Gratton et al.
5,522,388	A	6/1996	Ishikawa et al.	5,774,213	A	6/1998	Trebino et al.
5,524,617	A	6/1996	Mannheimer	5,776,058	A	7/1998	Levinson et al.
5,529,064	A	6/1996	Rall et al.	5,776,059	A	7/1998	Kaestle
5,533,507	A	7/1996	Potratz et al.	5,779,630	A	7/1998	Fein et al.
				5,779,631	A	7/1998	Chance
				5,782,237	A	7/1998	Casciani et al.
				5,782,756	A	7/1998	Mannheimer
				5,782,757	A	7/1998	Diab et al.

(56)

References Cited

U.S. PATENT DOCUMENTS

5,782,758 A	7/1998	Ausec et al.	5,978,693 A	11/1999	Hamilton et al.
5,786,592 A	7/1998	Hök	5,983,120 A	11/1999	Groner et al.
5,788,634 A	8/1998	Suda et al.	5,983,122 A	11/1999	Jarman et al.
5,790,729 A	8/1998	Pologe et al.	5,987,343 A	11/1999	Kinast
5,792,052 A	8/1998	Isaacson et al.	5,991,648 A	11/1999	Levin
5,795,292 A	8/1998	Lewis et al.	5,995,855 A	11/1999	Kiani et al.
5,797,841 A	8/1998	DeLonzor et al.	5,995,856 A	11/1999	Mannheimer et al.
5,800,348 A	9/1998	Kaestle	5,995,858 A	11/1999	Kinast
5,800,349 A	9/1998	Isaacson et al.	5,995,859 A	11/1999	Takahashi
5,803,910 A	9/1998	Potratz	5,997,343 A	12/1999	Mills et al.
5,807,246 A	9/1998	Sakaguchi et al.	5,999,834 A	12/1999	Wang et al.
5,807,247 A	9/1998	Merchant et al.	6,002,952 A	12/1999	Diab et al.
5,807,248 A	9/1998	Mills	6,005,658 A	12/1999	Kaluza et al.
5,810,723 A	9/1998	Aldrich	6,006,120 A	12/1999	Levin
5,810,724 A	9/1998	Gronvall	6,011,985 A	1/2000	Athan et al.
5,813,980 A	9/1998	Levinson et al.	6,011,986 A	1/2000	Diab et al.
5,817,008 A	10/1998	Rafert et al.	6,014,576 A	1/2000	Raley et al.
5,817,009 A	10/1998	Rosenheimer et al.	6,018,673 A	1/2000	Chin et al.
5,817,010 A	10/1998	Hibl	6,018,674 A	1/2000	Aronow
5,818,985 A	10/1998	Merchant et al.	6,022,321 A	2/2000	Amano et al.
5,820,550 A	10/1998	Polson et al.	6,023,541 A	2/2000	Merchant et al.
5,823,950 A	10/1998	Diab et al.	6,026,312 A	2/2000	Shemwell et al.
5,823,952 A	10/1998	Levinson et al.	6,026,314 A	2/2000	Amerov et al.
5,827,179 A	10/1998	Lichter et al.	6,031,603 A	2/2000	Fine et al.
5,827,182 A	10/1998	Raley et al.	6,035,223 A	3/2000	Baker, Jr.
5,829,439 A	11/1998	Yokosawa et al.	6,036,642 A	3/2000	Diab et al.
5,830,135 A	11/1998	Bosque et al.	6,041,247 A	3/2000	Weckstrom et al.
5,830,136 A	11/1998	Delonzor et al.	6,044,283 A	3/2000	Fein et al.
5,830,137 A	11/1998	Scharf	6,047,201 A	4/2000	Jackson, III
5,839,439 A	11/1998	Nierlich et al.	6,055,447 A	4/2000	Well
RE36,000 E	12/1998	Swedlow et al.	6,061,584 A	5/2000	Lovejoy et al.
5,842,979 A	12/1998	Jarman et al.	6,064,898 A	5/2000	Aldrich
5,842,981 A	12/1998	Larsen et al.	6,064,899 A	5/2000	Fein et al.
5,842,982 A	12/1998	Mannheimer	6,067,462 A	5/2000	Diab et al.
5,846,190 A	12/1998	Woehrl	6,073,038 A	6/2000	Wang et al.
5,851,178 A	12/1998	Aronow	6,078,829 A	6/2000	Uchida
5,851,179 A	12/1998	Ritson et al.	6,078,833 A	6/2000	Hueber
5,853,364 A	12/1998	Baker, Jr. et al.	6,081,735 A	6/2000	Diab et al.
5,860,919 A	1/1999	Kiani-Azarbayjany et al.	6,083,157 A	7/2000	Noller
5,865,736 A	2/1999	Baker, Jr. et al.	6,083,172 A	7/2000	Baker, Jr. et al.
5,879,294 A	3/1999	Anderson et al.	6,088,607 A	7/2000	Diab et al.
5,885,213 A	3/1999	Richardson et al.	6,094,592 A	7/2000	Yorkey et al.
5,890,929 A	4/1999	Mills et al.	6,095,974 A	8/2000	Shemwell et al.
5,891,021 A	4/1999	Dillon et al.	6,104,938 A	8/2000	Huiku et al.
5,891,022 A	4/1999	Pologe	6,104,939 A	8/2000	Groner
5,891,024 A	4/1999	Jarman et al.	6,112,107 A	8/2000	Hannula
5,891,025 A	4/1999	Buschmann et al.	6,113,541 A	9/2000	Dias et al.
5,891,026 A	4/1999	Wang et al.	6,115,621 A	9/2000	Chin
5,902,235 A	5/1999	Lewis et al.	6,122,535 A	9/2000	Kaestle et al.
5,910,108 A	6/1999	Solenberger	6,133,994 A	10/2000	Mathews et al.
5,911,690 A	6/1999	Rall	6,135,952 A	10/2000	Coetzee
5,912,656 A	6/1999	Tham et al.	6,144,444 A	11/2000	Haworth et al.
5,913,819 A	6/1999	Taylor et al.	6,144,867 A	11/2000	Walker et al.
5,916,154 A	6/1999	Hobbs et al.	6,144,868 A	11/2000	Parker
5,916,155 A	6/1999	Levinson et al.	6,147,850 A	11/2000	Gronowicz, Jr.
5,919,133 A	7/1999	Taylor et al.	6,149,481 A	11/2000	Wang et al.
5,919,134 A	7/1999	Diab	6,151,107 A	11/2000	Schöllermann et al.
5,920,263 A	7/1999	Huttenhoff et al.	6,151,516 A	11/2000	Kiani-Azarbayjany et al.
5,921,921 A	7/1999	Potratz et al.	6,151,518 A	11/2000	Hayashi
5,922,607 A	7/1999	Bernreuter	6,152,754 A	11/2000	Gerhardt et al.
5,924,979 A	7/1999	Swedlow et al.	6,154,667 A	11/2000	Miura et al.
5,924,980 A	7/1999	Coetzee	6,157,850 A	12/2000	Diab et al.
5,924,982 A	7/1999	Chin	6,159,147 A	12/2000	Lichter
5,924,985 A	7/1999	Jones	6,159,850 A	12/2000	Lee et al.
5,934,277 A	8/1999	Mortz	6,163,175 A	12/2000	Sharpe-Geisler
5,934,925 A	8/1999	Tobler et al.	6,163,715 A	12/2000	Larsen et al.
5,940,182 A	8/1999	Lepper, Jr. et al.	6,165,005 A	12/2000	Mills et al.
5,954,644 A	9/1999	Detling et al.	6,173,196 B1	1/2001	Delonzor et al.
5,957,840 A	9/1999	Terasawa et al.	6,178,343 B1	1/2001	Bindzus et al.
5,960,610 A	10/1999	Levinson et al.	6,179,159 B1	1/2001	Gurley
5,961,450 A	10/1999	Merchant et al.	6,181,958 B1	1/2001	Steuer et al.
5,961,452 A	10/1999	Chung et al.	6,181,959 B1	1/2001	Schollermann et al.
5,964,701 A	10/1999	Asada et al.	6,184,521 B1	2/2001	Coffin, IV et al.
5,971,930 A	10/1999	Elghazzawi	6,188,470 B1	2/2001	Grace
5,978,691 A	11/1999	Mills	6,192,260 B1	2/2001	Chance
			6,195,574 B1	2/2001	Kumar et al.
			6,195,575 B1	2/2001	Levinson
			6,198,951 B1	3/2001	Kosuda et al.
			6,206,830 B1	3/2001	Diab et al.

(56)

References Cited

U.S. PATENT DOCUMENTS

6,213,952	B1	4/2001	Finarov et al.	6,438,399	B1	8/2002	Kurth
6,217,523	B1	4/2001	Amano et al.	6,449,501	B1	9/2002	Reuss
6,222,189	B1	4/2001	Misner et al.	6,453,183	B1	9/2002	Walker
6,223,064	B1	4/2001	Lynn	6,453,184	B1	9/2002	Hyogo et al.
6,226,539	B1	5/2001	Potratz	6,456,862	B2	9/2002	Benni
6,226,540	B1	5/2001	Bernreuter et al.	6,461,305	B1	10/2002	Schnall
6,229,856	B1	5/2001	Diab et al.	6,463,310	B1	10/2002	Swedlow et al.
6,230,035	B1	5/2001	Aoyagi et al.	6,463,311	B1	10/2002	Diab
6,233,470	B1	5/2001	Tsuchiya	6,466,808	B1	10/2002	Chin et al.
6,236,871	B1	5/2001	Tsuchiya	6,466,809	B1	10/2002	Riley
6,236,872	B1	5/2001	Diab et al.	6,470,199	B1	10/2002	Kopotic et al.
6,240,305	B1	5/2001	Tsuchiya	6,470,200	B2	10/2002	Walker et al.
6,253,097	B1	6/2001	Aronow et al.	6,480,729	B2	11/2002	Stone
6,253,098	B1	6/2001	Walker et al.	6,490,466	B1	12/2002	Chew et al.
6,256,523	B1	7/2001	Diab et al.	6,493,568	B1	12/2002	Bell
6,256,524	B1	7/2001	Walker et al.	6,496,711	B1	12/2002	Athan et al.
6,261,236	B1	7/2001	Grinblatov	6,498,942	B1	12/2002	Esenaliev et al.
6,263,221	B1	7/2001	Chance et al.	6,501,974	B2	12/2002	Huiku
6,263,222	B1	7/2001	Diab et al.	6,501,975	B2	12/2002	Diab et al.
6,263,223	B1	7/2001	Sheperd et al.	6,505,060	B1	1/2003	Norris
6,266,546	B1	7/2001	Steuer et al.	6,505,061	B2	1/2003	Larson
6,266,547	B1	7/2001	Walker et al.	6,505,133	B1	1/2003	Hanna et al.
6,272,363	B1	8/2001	Casciani et al.	6,510,329	B2	1/2003	Heckel
6,278,522	B1	8/2001	Lepper, Jr. et al.	6,510,331	B1	1/2003	Williams et al.
6,280,213	B1	8/2001	Tobler et al.	6,512,937	B2	1/2003	Blank et al.
6,280,381	B1	8/2001	Malin et al.	6,515,273	B2	2/2003	Al-Ali
6,285,894	B1	9/2001	Oppelt et al.	6,519,484	B1	2/2003	Lovejoy et al.
6,285,895	B1	9/2001	Ristolainen et al.	6,519,486	B1	2/2003	Edgar, Jr. et al.
6,285,896	B1	9/2001	Tobler et al.	6,519,487	B1	2/2003	Parker
6,298,252	B1	10/2001	Kovach et al.	6,525,386	B1	2/2003	Mills et al.
6,308,089	B1	10/2001	Von der Ruhr et al.	6,526,300	B1	2/2003	Kiani et al.
6,321,100	B1	11/2001	Parker	6,526,301	B2	2/2003	Larsen et al.
6,330,468	B1	12/2001	Scharf	6,541,756	B2	4/2003	Schulz et al.
6,334,065	B1	12/2001	Al-Ali et al.	6,542,764	B1	4/2003	Al-Ali et al.
6,339,715	B1	1/2002	Bahr et al.	6,546,267	B1	4/2003	Sugiura et al.
6,342,039	B1	1/2002	Lynn	6,553,241	B2	4/2003	Mannheimer et al.
6,343,223	B1	1/2002	Chin et al.	6,553,242	B1	4/2003	Sarussi
6,343,224	B1	1/2002	Parker	6,553,243	B2	4/2003	Gurley
6,349,228	B1	2/2002	Kiani et al.	6,554,788	B1	4/2003	Hunley
6,351,658	B1	2/2002	Middleman et al.	6,556,852	B1	4/2003	Schulze et al.
6,353,750	B1	3/2002	Kimura	6,560,470	B1	5/2003	Pologe
6,356,774	B1	3/2002	Bernstein et al.	6,564,077	B2	5/2003	Mortara
6,360,113	B1	3/2002	Dettling	6,564,088	B1	5/2003	Soller et al.
6,360,114	B1	3/2002	Diab et al.	6,571,113	B1	5/2003	Fein et al.
6,361,501	B1	3/2002	Amano et al.	6,571,114	B1	5/2003	Koike et al.
6,363,269	B1	3/2002	Hanna et al.	6,574,491	B2	6/2003	Elghazzawi
D455,834	S	4/2002	Donars et al.	6,580,086	B1	6/2003	Schulz et al.
6,370,408	B1	4/2002	Merchant et al.	6,584,336	B1	6/2003	Ali et al.
6,370,409	B1	4/2002	Chung et al.	6,587,703	B2	7/2003	Cheng et al.
6,371,921	B1	4/2002	Caro	6,587,704	B1	7/2003	Fine et al.
6,374,129	B1	4/2002	Chin et al.	6,589,172	B2	7/2003	Williams et al.
6,377,829	B1	4/2002	Al-Ali et al.	6,591,122	B2	7/2003	Schmitt
6,381,479	B1	4/2002	Norris	6,591,123	B2	7/2003	Fein et al.
6,381,480	B1	4/2002	Stoddart et al.	6,594,511	B2	7/2003	Stone et al.
6,385,471	B1	5/2002	Mortz	6,594,512	B2	7/2003	Huang
6,385,821	B1	5/2002	Modgil et al.	6,594,513	B1	7/2003	Jobsis et al.
6,388,240	B2	5/2002	Schulz et al.	6,597,931	B1	7/2003	Cheng et al.
6,393,310	B1	5/2002	Kuenstner	6,597,933	B2	7/2003	Kiani et al.
6,393,311	B1	5/2002	Edgar, Jr. et al.	6,600,940	B1	7/2003	Fein et al.
6,397,091	B2	5/2002	Diab et al.	6,606,510	B2	8/2003	Swedlow et al.
6,397,092	B1	5/2002	Norris et al.	6,606,511	B1	8/2003	Ali et al.
6,397,093	B1	5/2002	Aldrich	6,606,512	B2	8/2003	Muz et al.
6,400,971	B1	6/2002	Finarov et al.	6,608,562	B1	8/2003	Kimura et al.
6,400,972	B1	6/2002	Fine	6,609,016	B1	8/2003	Lynn
6,400,973	B1	6/2002	Winter	6,615,064	B1	9/2003	Aldrich
6,402,690	B1	6/2002	Rhee et al.	6,615,065	B1	9/2003	Barrett et al.
6,408,198	B1	6/2002	Hanna et al.	6,618,602	B2	9/2003	Levin et al.
6,411,832	B1	6/2002	Guthermann	6,622,034	B1	9/2003	Gorski et al.
6,411,833	B1	6/2002	Baker, Jr. et al.	6,628,975	B1	9/2003	Fein et al.
6,421,549	B1	7/2002	Jacques	6,631,281	B1	10/2003	Kästle
6,430,423	B2	8/2002	DeLonzor et al.	6,632,181	B2	10/2003	Flaherty
6,430,513	B1	8/2002	Wang et al.	6,640,116	B2	10/2003	Diab
6,430,525	B1	8/2002	Weber et al.	6,643,530	B2	11/2003	Diab et al.
6,434,408	B1	8/2002	Heckel	6,643,531	B1	11/2003	Katarow
6,438,396	B1	8/2002	Cook	6,647,279	B2	11/2003	Pologe
				6,647,280	B2	11/2003	Bahr et al.
				6,650,916	B2	11/2003	Cook
				6,650,917	B2	11/2003	Diab et al.
				6,650,918	B2	11/2003	Terry

(56)

References Cited

U.S. PATENT DOCUMENTS

6,654,621	B2	11/2003	Palatnik et al.	6,802,812	B1	10/2004	Walker et al.
6,654,622	B1	11/2003	Eberhard et al.	6,805,673	B2	10/2004	Dekker
6,654,623	B1	11/2003	Kästle	6,810,277	B2	10/2004	Edgar, Jr. et al.
6,654,624	B2	11/2003	Diab et al.	6,813,511	B2	11/2004	Diab et al.
6,658,276	B2	12/2003	Kianl et al.	6,816,741	B2	11/2004	Diab
6,658,277	B2	12/2003	Wassermann	6,819,950	B2	11/2004	Mills
6,662,033	B2	12/2003	Casciani et al.	6,822,564	B2	11/2004	Al-Ali
6,665,551	B1	12/2003	Suzuki	6,825,619	B2	11/2004	Norris
6,668,182	B2	12/2003	Hubelbank	6,826,419	B2	11/2004	Diab et al.
6,668,183	B2	12/2003	Hicks et al.	6,829,496	B2	12/2004	Nagai et al.
6,671,526	B1	12/2003	Aoyagi et al.	6,830,711	B2	12/2004	Mills et al.
6,671,528	B2	12/2003	Steuer et al.	6,836,679	B2	12/2004	Baker, Jr. et al.
6,671,530	B2	12/2003	Chung et al.	6,839,579	B1	1/2005	Chin
6,671,531	B2	12/2003	Al-Ali et al.	6,839,580	B2	1/2005	Zonios et al.
6,671,532	B1	12/2003	Fudge et al.	6,839,582	B2	1/2005	Heckel
6,675,031	B1	1/2004	Porges et al.	6,839,659	B2	1/2005	Tarassenko et al.
6,678,543	B2	1/2004	Diab et al.	6,842,635	B1	1/2005	Parker
6,681,126	B2	1/2004	Solenberger	6,845,256	B2	1/2005	Chin et al.
6,681,128	B2	1/2004	Steuer et al.	6,850,787	B2	2/2005	Weber et al.
6,681,454	B2	1/2004	Modgil et al.	6,850,788	B2	2/2005	Al-Ali
6,684,090	B2	1/2004	Ali et al.	6,850,789	B2	2/2005	Schweitzer, Jr. et al.
6,684,091	B2	1/2004	Parker	6,861,639	B2	3/2005	Al-Ali
6,694,160	B2	2/2004	Chin	6,863,652	B2	3/2005	Huang et al.
6,697,653	B2	2/2004	Hanna	6,865,407	B2	3/2005	Kimball et al.
6,697,655	B2	2/2004	Sueppel et al.	6,873,865	B2	3/2005	Steuer et al.
6,697,656	B1	2/2004	Al-Ali	6,879,850	B2	4/2005	Kimball
6,697,658	B2	2/2004	Al-Ali	6,882,874	B2	4/2005	Huiku
RE38,476	E	3/2004	Diab et al.	6,898,452	B2	5/2005	Al-Ali et al.
6,699,194	B1	3/2004	Diab et al.	6,909,912	B2	6/2005	Melker et al.
6,699,199	B2	3/2004	Asada et al.	6,912,413	B2	6/2005	Rantala et al.
6,701,170	B2	3/2004	Stetson	6,920,345	B2	7/2005	Al-Ali et al.
6,702,752	B2	3/2004	Dekker	6,931,269	B2	8/2005	Terry
6,707,257	B2	3/2004	Norris	6,934,570	B2	8/2005	Kiani et al.
6,708,049	B1	3/2004	Berson et al.	6,941,162	B2	9/2005	Fudge et al.
6,709,402	B2	3/2004	Dekker	6,947,781	B2	9/2005	Asada et al.
6,711,424	B1	3/2004	Fine et al.	6,950,687	B2	9/2005	Al-Ali
6,711,425	B1	3/2004	Reuss	6,954,664	B2	10/2005	Sweitzer
6,712,762	B1	3/2004	Lichter	6,968,221	B2	11/2005	Rosenthal
6,714,803	B1	3/2004	Mortz	6,979,812	B2	12/2005	Al-Ali
6,714,804	B2	3/2004	Al-Ali et al.	6,983,178	B2	1/2006	Fine et al.
6,714,805	B2	3/2004	Jeon et al.	6,985,763	B2	1/2006	Boas et al.
RE38,492	E	4/2004	Diab et al.	6,985,764	B2	1/2006	Mason et al.
6,719,686	B2	4/2004	Coakley et al.	6,990,426	B2	1/2006	Yoon et al.
6,719,705	B2	4/2004	Mills	6,992,751	B2	1/2006	Okita et al.
6,720,734	B2	4/2004	Norris	6,992,772	B2	1/2006	Block
6,721,584	B2	4/2004	Baker, Jr. et al.	6,993,371	B2	1/2006	Kiani et al.
6,721,585	B1	4/2004	Parker	6,993,372	B2	1/2006	Fine et al.
6,725,074	B1	4/2004	Kästle	6,996,427	B2	2/2006	Ali et al.
6,725,075	B2	4/2004	Al-Ali	7,003,338	B2	2/2006	Weber et al.
6,731,962	B1	5/2004	Katarow	7,003,339	B2	2/2006	Diab et al.
6,731,963	B2	5/2004	Finarov et al.	7,006,855	B1	2/2006	Sarussi
6,731,967	B1	5/2004	Turcott	7,006,856	B2	2/2006	Baker, Jr. et al.
6,735,459	B2	5/2004	Parker	7,016,715	B2	3/2006	Stetson
6,745,060	B2	6/2004	Diab et al.	7,020,507	B2	3/2006	Scharf et al.
6,745,061	B1	6/2004	Hicks et al.	7,024,233	B2	4/2006	Ali et al.
6,748,253	B2	6/2004	Norris et al.	7,024,235	B2	4/2006	Melker et al.
6,748,254	B2	6/2004	Chin et al.	7,025,728	B2	4/2006	Ito et al.
6,754,515	B1	6/2004	Pologe	7,027,849	B2	4/2006	Al-Ali
6,754,516	B2	6/2004	Mannheimer	7,027,850	B2	4/2006	Wasserman
6,760,607	B2	7/2004	Al-All	7,039,449	B2	5/2006	Al-Ali
6,760,609	B2	7/2004	Jacques	7,043,289	B2	5/2006	Fine et al.
6,760,610	B2	7/2004	Tschupp et al.	7,047,055	B2	5/2006	Boas et al.
6,763,255	B2	7/2004	DeLonzor et al.	7,060,035	B2	6/2006	Wasserman
6,763,256	B2	7/2004	Kimball et al.	7,062,307	B2	6/2006	Norris et al.
6,770,028	B1	8/2004	Ali et al.	7,067,893	B2	6/2006	Mills et al.
6,771,994	B2	8/2004	Kiani et al.	7,072,701	B2	7/2006	Chen et al.
6,773,397	B2	8/2004	Kelly	7,072,702	B2	7/2006	Edgar, Jr. et al.
6,778,923	B2	8/2004	Norris et al.	7,079,880	B2	7/2006	Stetson
6,780,158	B2	8/2004	Yarita	7,085,597	B2	8/2006	Fein et al.
6,791,689	B1	9/2004	Weckstrom	7,096,052	B2	8/2006	Mason et al.
6,792,300	B1	9/2004	Diab et al.	7,096,054	B2	8/2006	Abdul-Hafiz et al.
6,801,797	B2	10/2004	Mannheimer et al.	7,107,088	B2	9/2006	Aceti
6,801,798	B2	10/2004	Geddes et al.	7,112,175	B2	9/2006	Gopinathan et al.
6,801,799	B2	10/2004	Mendelson	7,113,815	B2	9/2006	O'Neil et al.
6,801,802	B2	10/2004	Sitzman et al.	7,123,950	B2	10/2006	Mannheimer
				7,127,278	B2	10/2006	Melker et al.
				7,130,671	B2	10/2006	Baker, Jr. et al.
				7,132,641	B2	11/2006	Schulz et al.
				7,133,711	B2	11/2006	Chernoguz et al.

(56)

References Cited

U.S. PATENT DOCUMENTS

7,139,559	B2	11/2006	Kenagy et al.	2004/0147824	A1	7/2004	Diab et al.
7,142,901	B2	11/2006	Kiani et al.	2004/0158134	A1	8/2004	Diab et al.
7,162,288	B2	1/2007	Nordstrom et al.	2004/0162472	A1	8/2004	Berson et al.
7,164,938	B2	1/2007	Geddes et al.	2004/0167381	A1	8/2004	Lichter
7,190,986	B1	3/2007	Hannula et al.	2004/0186358	A1	9/2004	Chernow et al.
7,190,987	B2	3/2007	Kindekugel et al.	2004/0199063	A1	10/2004	O'Neil et al.
7,198,778	B2	4/2007	Achilefu et al.	2004/0204637	A1	10/2004	Diab et al.
7,215,984	B2	5/2007	Diab et al.	2004/0204638	A1	10/2004	Diab et al.
7,225,006	B2	5/2007	Al-Ali et al.	2004/0204639	A1	10/2004	Casciani et al.
7,228,161	B2	6/2007	Chin	2004/0204865	A1	10/2004	Lee et al.
7,236,881	B2	6/2007	Liu et al.	2004/0210146	A1	10/2004	Diab et al.
7,245,953	B1	7/2007	Parker	2004/0215085	A1	10/2004	Schnall
7,248,910	B2	7/2007	Li et al.	2004/0236196	A1	11/2004	Diab et al.
7,254,433	B2	8/2007	Diab et al.	2004/0257557	A1	12/2004	Block
7,254,434	B2	8/2007	Schulz et al.	2004/0260161	A1	12/2004	Melker et al.
7,255,006	B2	8/2007	Spanke et al.	2005/0004479	A1	1/2005	Townsend et al.
7,257,438	B2	8/2007	Kinast	2005/0014999	A1	1/2005	Rahe-Meyer
7,263,396	B2	8/2007	Chen et al.	2005/0020887	A1	1/2005	Goldberg
7,272,425	B2	9/2007	Al-Ali	2005/0033131	A1	2/2005	Chen
7,280,858	B2	10/2007	Al-Ali et al.	2005/0038050	A1	2/2005	Moore et al.
7,292,150	B2	11/2007	Shaw	2005/0043599	A1	2/2005	O'Mara
7,295,866	B2	11/2007	Al-Ali	2005/0043600	A1	2/2005	Diab et al.
7,305,262	B2	12/2007	Brodnick et al.	2005/0049468	A1	3/2005	Carlson
7,315,753	B2	1/2008	Baker, Jr. et al.	2005/0049471	A1	3/2005	Aceti et al.
7,341,559	B2	3/2008	Schulz et al.	2005/0059869	A1	3/2005	Scharf et al.
7,341,560	B2	3/2008	Henderson et al.	2005/0070773	A1	3/2005	Chin
7,359,741	B2	4/2008	Sarussi et al.	2005/0075546	A1	4/2005	Samsoondar
7,359,742	B2	4/2008	Maser et al.	2005/0075550	A1	4/2005	Lindekugel
7,412,272	B2	8/2008	Medina et al.	2005/0085704	A1	4/2005	Schulz
7,433,726	B2	10/2008	Perkins	2005/0090720	A1	4/2005	Wu
7,435,222	B2	10/2008	Gopinathan et al.	2005/0119538	A1	6/2005	Jeon et al.
2002/0016537	A1	2/2002	Muz et al.	2005/0163412	A1	7/2005	Glebov et al.
2002/0026109	A1	2/2002	Diab et al.	2005/0197548	A1	9/2005	Dietiker
2002/0028990	A1	3/2002	Sheperd et al.	2005/0228248	A1	10/2005	Dietiker
2002/0038078	A1	3/2002	Ito	2005/0228300	A1	10/2005	Jaime et al.
2002/0042558	A1	4/2002	Mendelson	2005/0256386	A1	11/2005	Chan
2002/0068859	A1	6/2002	Knopp	2005/0272986	A1	12/2005	Smith
2002/0072681	A1	6/2002	Schnall	2005/0277819	A1	12/2005	Kiani et al.
2002/0103423	A1	8/2002	Chin et al.	2005/0283082	A1	12/2005	Geddes et al.
2002/0116797	A1	8/2002	Modgil et al.	2006/0020179	A1	1/2006	Anderson
2002/0128544	A1	9/2002	Diab et al.	2006/0030764	A1	2/2006	Porges
2002/0133067	A1	9/2002	Jackson, III	2006/0036136	A1	2/2006	Shaw
2002/0151775	A1	10/2002	Kondo	2006/0058594	A1	3/2006	Ishizuka et al.
2002/0156354	A1	10/2002	Larson	2006/0058690	A1	3/2006	Bartnik
2002/0173706	A1	11/2002	Takatani	2006/0064024	A1	3/2006	Schnall
2002/0173709	A1	11/2002	Fine et al.	2006/0069319	A1	3/2006	Elhag et al.
2002/0190863	A1	12/2002	Lynn	2006/0074280	A1	4/2006	Martis
2003/0018243	A1	1/2003	Gerhardt et al.	2006/0079794	A1	4/2006	Liu et al.
2003/0036690	A1	2/2003	Geddes et al.	2006/0084852	A1	4/2006	Mason et al.
2003/0045785	A1	3/2003	Diab et al.	2006/0084878	A1	4/2006	Banet
2003/0073889	A1	4/2003	Keilbach et al.	2006/0089547	A1	4/2006	Sarussi
2003/0073890	A1	4/2003	Hanna	2006/0106294	A1	5/2006	Maser et al.
2003/0100840	A1	5/2003	Sugiura et al.	2006/0122517	A1	6/2006	Banet
2003/0109775	A1	6/2003	O'Neil et al.	2006/0129039	A1	6/2006	Lindner
2003/0171662	A1	9/2003	O'Connor et al.	2006/0149149	A1	7/2006	Schmid
2003/0181799	A1	9/2003	Lindekugel et al.	2006/0155198	A1	7/2006	Schmid
2003/0187337	A1	10/2003	Tarassenko et al.	2006/0173257	A1	8/2006	Nagai
2003/0197679	A1	10/2003	Ali et al.	2006/0200018	A1	9/2006	Al-Ali
2003/0212316	A1	11/2003	Leiden et al.	2006/0253010	A1	11/2006	Brady et al.
2003/0225323	A1	12/2003	Kiani et al.	2006/0276700	A1	12/2006	O'Neil et al.
2004/0006261	A1	1/2004	Swedlow et al.	2007/0021659	A1	1/2007	Delonzor et al.
2004/0024326	A1	2/2004	Yeo et al.	2007/0021660	A1	1/2007	Delonzor et al.
2004/0039272	A1	2/2004	Abdul-Hafiz et al.	2007/0021662	A1	1/2007	Delonzor et al.
2004/0039273	A1	2/2004	Terry	2007/0027376	A1	2/2007	Todokoro et al.
2004/0044276	A1	3/2004	Arnold	2007/0027378	A1	2/2007	Delonzor et al.
2004/0054291	A1	3/2004	Schulz et al.	2007/0027379	A1	2/2007	Delonzor et al.
2004/0068164	A1	4/2004	Diab et al.	2007/0027380	A1	2/2007	Delonzar et al.
2004/0092805	A1	5/2004	Yarita	2007/0032707	A1	2/2007	Coakley et al.
2004/0097797	A1	5/2004	Porges et al.	2007/0032708	A1	2/2007	Eghbal et al.
2004/0098009	A1	5/2004	Boecker et al.	2007/0032709	A1	2/2007	Coakley et al.
2004/0117891	A1	6/2004	Hannula et al.	2007/0032710	A1	2/2007	Raridan et al.
2004/0122302	A1	6/2004	Mason et al.	2007/0032711	A1	2/2007	Coakley et al.
2004/0133088	A1	7/2004	Al-Ali	2007/0032712	A1	2/2007	Raridan et al.
2004/0143172	A1	7/2004	Fudge et al.	2007/0032715	A1	2/2007	Eghbal et al.
2004/0147821	A1	7/2004	Al-Ali et al.	2007/0032716	A1	2/2007	Raridan et al.
				2007/0038050	A1	2/2007	Sarussi
				2007/0060808	A1	3/2007	Hoarau
				2007/0073117	A1	3/2007	Raridan
				2007/0073121	A1	3/2007	Hoarau et al.

(56)

References Cited

U.S. PATENT DOCUMENTS

2007/0073122 A1 3/2007 Hoarau
 2007/0073123 A1 3/2007 Raridan
 2007/0073125 A1 3/2007 Hoarau et al.
 2007/0073126 A1 3/2007 Raridan
 2007/0073128 A1 3/2007 Hoarau
 2007/0078315 A1 4/2007 Kling et al.
 2007/0078316 A1 4/2007 Hoarau
 2007/0106132 A1 5/2007 Elhag et al.
 2007/0219440 A1 9/2007 Hannula et al.
 2007/0260129 A1 11/2007 Chin
 2007/0260130 A1 11/2007 Chin
 2007/0260131 A1 11/2007 Chin
 2007/0299328 A1 12/2007 Chin et al.
 2008/0009691 A1 1/2008 Parker et al.
 2008/0200786 A1 8/2008 Berndsen
 2008/0262328 A1 10/2008 Adams

FOREIGN PATENT DOCUMENTS

DE 3516338 11/1986
 DE 3703458 8/1988
 DE 3938759 5/1991
 DE 4210102 9/1993
 DE 4423597 8/1995
 DE 19632361 2/1997
 DE 69123448 5/1997
 DE 19703220 7/1997
 DE 19640807 9/1997
 DE 19647877 4/1998
 DE 10030862 1/2002
 DE 20318882 4/2004
 EP 0127947 5/1984
 EP 0194105 9/1986
 EP 0204459 12/1986
 EP 0262779 4/1988
 EP 0315040 10/1988
 EP 0314331 5/1989
 EP 00352923 1/1990
 EP 0360 977 4/1990
 EP 430340 6/1991
 EP 435500 7/1991
 EP 0572684 5/1992
 EP 00497021 8/1992
 EP 0529412 8/1992
 EP 0531631 9/1992
 EP 0566354 4/1993
 EP 0587009 8/1993
 EP 00630203 9/1993
 EP 0572684 12/1993
 EP 00615723 9/1994
 EP 00702931 3/1996
 EP 00724860 8/1996
 EP 00793942 9/1997
 EP 0864293 9/1998
 EP 01006863 10/1998
 EP 01006864 10/1998
 EP 0875199 11/1998
 EP 00998214 12/1998
 EP 0898933 3/1999
 EP 01332713 8/2003
 EP 01469773 8/2003
 EP 1502529 7/2004
 EP 1491135 12/2004
 EP 1807001 7/2007
 FR 2685865 1/1992
 GB 2259545 3/1993
 JP 63275325 11/1988
 JP 2013450 1/1990
 JP 2111343 4/1990
 JP 2191434 7/1990
 JP 2237544 9/1990
 JP 3170866 7/1991
 JP 3173536 7/1991
 JP 3245042 10/1991

JP 4174648 6/1992
 JP 4191642 7/1992
 JP 4332536 11/1992
 JP 3124073 3/1993
 JP 5049624 3/1993
 JP 5049625 3/1993
 JP 3115374 4/1993
 JP 5200031 8/1993
 JP 5212016 8/1993
 JP 06014906 1/1994
 JP 6016774 3/1994
 JP 3116255 4/1994
 JP 6029504 4/1994
 JP 6098881 4/1994
 JP 06 154177 6/1994
 JP 06269430 9/1994
 JP 06285048 10/1994
 JP 07001273 1/1995
 JP 07124138 5/1995
 JP 07136150 5/1995
 JP 03116259 6/1995
 JP 03116260 6/1995
 JP 07155311 6/1995
 JP 07155313 6/1995
 JP 03238813 7/1995
 JP 07171139 7/1995
 JP 03134144 9/1995
 JP 07236625 9/1995
 JP 07246191 9/1995
 JP 08256996 10/1996
 JP 09192120 7/1997
 JP 10216113 8/1998
 JP 10216114 8/1998
 JP 10216115 8/1998
 JP 10337282 12/1998
 JP 11019074 1/1999
 JP 11155841 6/1999
 JP 11188019 7/1999
 JP 11244268 9/1999
 JP 20107157 4/2000
 JP 20237170 9/2000
 JP 21245871 9/2001
 JP 22224088 8/2002
 JP 22282242 10/2002
 JP 23153881 5/2003
 JP 23153882 5/2003
 JP 23169791 6/2003
 JP 23194714 7/2003
 JP 23210438 7/2003
 JP 23275192 9/2003
 JP 23339678 12/2003
 JP 24008572 1/2004
 JP 24089546 3/2004
 JP 24113353 4/2004
 JP 24135854 5/2004
 JP 24148069 5/2004
 JP 24148070 5/2004
 JP 24159810 6/2004
 JP 24166775 6/2004
 JP 24194908 7/2004
 JP 24202190 7/2004
 JP 24248819 9/2004
 JP 24248820 9/2004
 JP 24261364 9/2004
 JP 24290412 10/2004
 JP 24290544 10/2004
 JP 24290545 10/2004
 JP 24329406 11/2004
 JP 24329607 11/2004
 JP 24329928 11/2004
 JP 24337605 12/2004
 JP 24344367 12/2004
 JP 24351107 12/2004
 JP 25034472 2/2005
 JP 25110816 4/2005
 JP 25125106 5/2005
 JP 25168600 6/2005
 JP 26122458 5/2006
 JP 26122693 5/2006

(56)

References Cited

FOREIGN PATENT DOCUMENTS

WO	WO9809566	10/1989
WO	WO9001293	2/1990
WO	WO9004352	5/1990
WO	WO9101678	2/1991
WO	WO9111137	8/1991
WO	WO9200513	1/1992
WO	WO9221281	12/1992
WO	WO9309711	5/1993
WO	WO9313706	7/1993
WO	WO9316629	9/1993
WO	WO9403102	2/1994
WO	WO9423643	10/1994
WO	WO9502358	1/1995
WO	WO9512349	5/1995
WO	WO9516970	6/1995
WO	WO9613208	5/1996
WO	WO9616591	6/1996
WO	WO9639927	12/1996
WO	WO9736536	10/1997
WO	WO9736538	10/1997
WO	WO9749330	12/1997
WO	WO9817174	4/1998
WO	WO9818382	5/1998
WO	WO9843071	10/1998
WO	WO9851212	11/1998
WO	WO9857577	12/1998
WO	WO9900053	1/1999
WO	WO9932030	7/1999
WO	WO9947039	9/1999
WO	WO9963884	12/1999
WO	WO0021438	4/2000
WO	WO0028888	5/2000
WO	WO0059374	10/2000
WO	WO0113790	3/2001
WO	WO0116577	3/2001
WO	WO0117421	3/2001
WO	WO0147426	3/2001
WO	WO0140776	6/2001
WO	WO0167946	9/2001
WO	WO0176461	10/2001
WO	WO0214793	2/2002
WO	WO0235999	5/2002
WO	WO02062213	8/2002
WO	WO02074162	9/2002
WO	WO02085202	10/2002
WO	WO03000125	1/2003
WO	WO03001180	1/2003
WO	WO03009750	2/2003
WO	WO03011127	2/2003
WO	WO03020129	3/2003
WO	WO03039326	5/2003
WO	WO03063697	8/2003
WO	WO03073924	9/2003
WO	WO2004000114	12/2003
WO	WO2004006748	1/2004
WO	WO2004069046	8/2004
WO	WO2004075746	9/2004
WO	WO2005002434	1/2005
WO	WO2005/010567	2/2005
WO	WO2005009221	2/2005
WO	WO2005010568	2/2005
WO	WO2005020120	3/2005
WO	WO2005053530	6/2005
WO	WO2005065540	7/2005
WO	WO2006064399	6/2006
WO	WO2006110488	10/2006

OTHER PUBLICATIONS

Zahar, N., et al.; "Automatic Feedback Control of Oxygen Therapy Using Pulse Oximetry," *Annual International Conference of the IEEE Engineering in Medicine and Biology Society*, vol. 13, No. 4, pp. 1614-1615 (1991).

Aoyagi, T., et al.; "Analysis of Motion Artifacts in Pulse Oximetry," *Japanese Society ME*, vol. 42, p. 20 (1993) (Article in Japanese—contains English summary of article).

Barreto, A.B., et al.; "Adaptive Cancellation of Motion artifact in Photoplethysmographic Blood Volume Pulse Measurements for Exercise Evaluation," *IEEE-EMBC and CMBC—Theme 4: Signal Processing*, pp. 983-984 (1995).

Vincente, L.M., et al.; "Adaptive Pre-Processing of Photoplethysmographic Blood Volume Pulse Measurements," pp. 114-117 (1996).

Barreto, Armando B., et al.; "Adaptive LMS Delay Measurement in dual Blood Volume Pulse Signals for Non-Invasive Monitoring," *IEEE*, pp. 117-120 (1997).

Block, Frank E., Jr., et al.; "Technology evaluation report: Obtaining pulse oximeter signals when the usual probe cannot be used," *International journal of clinical Monitoring and Computing*, vol. 14, pp. 23-28 (1997).

Buschman, J.P., et al.; "Principles and Problems of Calibration of Fetal Oximeters," *Biomedizinische Technik*, vol. 42, pp. 265-266 (1997).

Faisst, Karin, et al.; "Intrapartum Reflectance Pulse Oximetry: Effects of Sensor Location and Fixation Duration on Oxygen Saturation Readings," *Journal of Clinical Monitoring*, vol. 13, pp. 299-302 (1997).

Izumi, Akio, et al.; "Accuracy and Utility of a New Reflectance Pulse Oximeter for Fetal Monitoring During Labor," *Journal of Clinical Monitoring*, vol. 13, pp. 103-108 (1997).

Leahy, Martin J., et al.; "Sensor Validation in Biomedical Applications," *IFAC Modelling and Control in Biomedical Systems*, Warwick, UK; pp. 221-226 (1997).

Nijland, Roel, et al.; "Validation of Reflectance Pulse Oximetry: An Evaluation of a new Sensor in Piglets," *Journal of Clinical Monitoring*, vol. 13, pp. 43-49 (1997).

Nogawa, Masamichi, et al.; "A New Hybrid Reflectance Optical Pulse Oximetry Sensor for Lower Oxygen Saturation Measurement and for Broader Clinical Application," *SPIE*, vol. 2976, pp. 78-87 (1997).

Plummer, John L., et al.; "Identification of Movement Artifact by the Nellcor N-200 and N-3000 Pulse Oximeters," *Journal of clinical Monitoring*, vol. 13, pp. 109-113 (1997).

Poets, C. F., et al.; "Detection of movement artifact in recorded pulse oximeter saturation," *Eur. J. Pediatr.*; vol. 156, pp. 808-811 (1997).

Crilly, Paul B., et al.; "An Integrated Pulse Oximeter System for Telemedicine Applications," *IEEE Instrumentation and Measurement Technology Conference*, Ottawa, Canada; May 19-21, 1997; pp. 102-104.

Mannheimer, Paul D., et al.; "Wavelength Selection for Low-Saturation Pulse Oximetry," *IEEE Transactions on Biomedical Engineering*, vol. 44, No. 3, pp. 148-158 (Mar. 1997).

Soto, Denise A.; "A Comparative Study of Pulse Oximeter Measurements: Digit Versus Earlobe," Master of Science Thesis, California State University Dominguez Hills, May 1997, 46 pgs.

"Smaller Product, Tighter Tolerances Pose Dispensing Challenges for Medical Device Manufacturer," *Adhesives Age*, pp. 40-41 (Oct. 1997).

Barnum, P.T., et al.; "Novel Pulse Oximetry Technology Capable of Reliable Bradycardia Monitoring in the Neonate," *Respiratory Care*, vol. 42, No. 1, p. 1072 (Nov. 1997).

Masin, Donald I., et al.; "Fetal Transmission Pulse Oximetry," *Proceedings 19th International Conference IEEE/EMBS*, Oct. 30-Nov. 2, 1997; pp. 2326-2329.

Pickett, John, et al.; "Pulse Oximetry and PPG Measurements in Plastic Surgery," *Proceedings—19th International Conference—IEEE/EMBS*, Chicago, Illinois, Oct. 30-Nov. 2, 1997, pp. 2330-2332.

DeKock, Marc; "Pulse Oximetry Probe Adhesive Disks: a Potential for Infant Aspiration," *Anesthesiology*, vol. 89, pp. 1603-1604 (1998).

Edrich, Thomas, et al.; "Can the Blood Content of the Tissues be Determined Optically During Pulse Oximetry Without Knowledge of the Oxygen Saturation?—An In-Vitro Investigation," *Proceedings of the 20th Annual International conference of the IEEE Engineering in Medicine and Biology Society*, vol. 20, No. 6, pp. 3072-3075 (1998).

Ferrell, T.L., et al.; "Medical Telesensors," *SPIE*, vol. 3253, pp. 193-198 (1998).

(56)

References Cited

OTHER PUBLICATIONS

- König, Volker, et al.; "Reflectance Pulse Oximetry—Principles and Obstetric Application in the Zurich System," *Journal of Clinical Monitoring and Computing*, vol. 14, pp. 403-412 (1998).
- Lutter, N., et al.; "Comparison of Different Evaluation Methods for a Multi-wavelength Pulse Oximeter," *Biomedizinische Technik*, vol. 43, (1998).
- Nogawa, Masamichi, et al.; "A Novel Hybrid Reflectance Pulse Oximeter Sensor with improved Linearity and General Applicability to Various Portions of the Body," *Proceedings of the 20th Annual International Conference of the IEEE Engineering in Medicine and Biology Society*, vol. 20, No. 4, pp. 1858-1861 (1998).
- Odagiri, Y.; "Pulse Wave Measuring Device," *Micromechanics*, vol. 42, No. 3, pp. 6-11 (1998) (Article in Japanese—contains English summary of article).
- Such, Hans Olaf; "Optoelectronic Non-invasive Vascular Diagnostics Using multiple Wavelength and Imaging Approach," *Dissertation*, (1998).
- Yang, Boo-Ho, et al.; "A Twenty-Four Hour Tele-Nursing System Using a Ring Sensor," *Proceedings of the 1998 IEEE International Conference on Robotics & Automation*, Leaven, Belgium, May 1998; pp. 387-392.
- East, Christine E., et al.; "Fetal Oxygen Saturation and Uterine Contractions During Labor," *American Journal of Perinatology*, vol. 15, No. 6, pp. 345-349 (Jun. 1998).
- Hayes, Matthew J., et al.; "Quantitative evaluation of photoplethysmographic artifact reduction for pulse oximetry," *SPIE*, vol. 3570, pp. 138-147 (Sep. 1998).
- Rhee, Sokwoo, et al.; "The Ring Sensor: a New Ambulatory Wearable Sensor for Twenty-Four Hour Patient Monitoring," *Proceedings of the 20th Annual International Conference of the IEEE Engineering in Medicine and Biology Society*, vol. 20, No. 4, pp. 1906-1909 (Oct. 1998).
- Hayes, Matthew J., et al.; "Artifact reduction in photoplethysmography," *Applied Optics*, vol. 37, No. 31, pp. 7437-7446 (Nov. 1998).
- Ikeda, Kenji, et al.; "Improvement of Photo-Electric Plethysmograph Applying Newly Developed OptoElectronic Devices," *IEEE Tencon*, pp. 1109-1112 (1999).
- Kaestle, S.; "An Algorithm for Reliable Processing of Pulse Oximetry Signals Under strong Noise Conditions," *Dissertation Book*, Lubeck University, Germany (1999).
- Rheineck-Leyssius, Aart t., et al.; "Advanced Pulse Oximeter Signal Processing Technology Compared to Simple Averaging: I. Effect on Frequency of Alarms in the Operating Room," *Journal of clinical Anesthesia*, vol. 11, pp. 192-195 (1999).
- Rohling, Roman, et al.; "Clinical Investigation of a New Combined Pulse Oximetry and Carbon Dioxide Tension Sensor in Adult Anaesthesia," *Journal of Clinical Monitoring and Computing*, vol. 15; pp. 23-27 (1999).
- Seelbach-Gobel, Birgit, et al.; "The prediction of fetal acidosis by means of intrapartum fetal pulse oximetry," *Am J. Obstet. Gynecol.*, vol. 180, No. 1, Part 1, pp. 73-81 (1999).
- Todd, Bryan, et al.; "The Identification of Peaks in Physiological Signals," *Computers and Biomedical Research*, vol. 32, pp. 322-335 (1999).
- Rhee, Sokwoo, et al.; "Design of a Artifact-Free Wearable Plethysmographic Sensor," *Proceedings of the First joint BMES/EMBS Conference*, Oct. 13-16, 1999, Atlanta, Georgia, p. 786.
- Aoyagi, T., et al.; "Pulse Oximeters: background, present and future," *Neonatal Care*, vol. 13, No. 7, pp. 21-27 (2000) (Article in Japanese—contains English summary of article).
- Goldman, Julian M.; "Masimo Signal Extraction Pulse Oximetry," *Journal of Clinical Monitoring and Computing*, vol. 16, pp. 475-483 (2000).
- Hamilton, Patrick S., et al.; "Effect of Adaptive Motion-Artifact Reduction on QRS Detection," *Biomedical Instrumentation & Technology*, pp. 197-202 (2000).
- Kaestle, S.; "Determining Artefact Sensitivity of New Pulse Oximeters in Laboratory Using Signals Obtained from Patient," *Biomedizinische Technik*, vol. 45 (2000).
- Nilsson, Lena, et al.; "Monitoring of Respiratory Rate in Postoperative Care Using a New Photoplethysmographic Technique," *Journal of Clinical Monitoring and Computing*, vol. 16, pp. 309-315 (2000).
- Vicenzi, Martin N.; "Transesophageal versus surface pulse oximetry in intensive care unit patients," *Crit. Care Med.*; vol. 28, No. 7, pp. 2268-2270 (2000).
- Yang, Boo-Ho, et al.; "Development of the ring sensor for healthcare automation," *Robotics and Autonomous Systems*, vol. 30, pp. 273-281 (2000).
- Yokota, Nakaura, Takahashi, et al.; "Pilot Model of a Reflectance-Type Pulse Oximeter for Pre-hospital Evaluation," *Journal of the Japanese Society of Emergency Medicine*, Kanto Region, vol. 21, pp. 26-27 (2000) (Article in Japanese—contains English summary of article).
- Edrich, Thomas, et al.; "Pulse Oximetry: An Improved in Vitro Model that Reduces Blood Flow-Related Artifacts," *IEEE Transactions on Biomedical Engineering*, vol. 47, No. 3, pp. 338-343 (Mar. 2000).
- Schulz, Christian Eric; "Design of a Pulse Oximetry Sensor Housing Assembly," California State University Master's Thesis, *UMI Dissertation Services*, UMI No. 1401306, (May 2000) 63 pages.
- Rhee, Sokwoo, et al.; "Artifact-Resistant, Power-Efficient Design of Finger-Ring Plethysmographic Sensor—Part I: Design and Analysis," *Proceedings of the 22nd Annual EMBS International Conference*, Chicago, Illinois; Jul. 23-28, 2000; pp. 2792-2795.
- Rhee, Sokwoo, et al.; "Artifact-Resistant, Power-Efficient Design of Finger-Ring Plethysmographic Sensor—Part II: Prototyping and Benchmarking," *Proceedings of the 22nd Annual EMBS International Conference*, Chicago, Illinois; Jul. 23-28, 2000; pp. 2796-2799.
- Coetzee, Frans M.; "Noise-Resistant Pulse Oximetry Using a Synthetic Reference Signal," *IEEE Transactions on Biomedical Engineering*, vol. 47, No. 8, Aug. 2000, pp. 1018-1026.
- Nijland, Mark J.M., et al.; "Assessment of fetal scalp oxygen saturation determination in the sheep by transmission pulse oximetry," *Am. J. Obstet Gynecol.*, vol. 183, No. 6, pp. 1549-1553 (Dec. 2000).
- Belal, Suliman Yousef, et al.; "A fuzzy system for detecting distorted plethysmogram pulses in neonates and paediatric patients," *Physiol. Meas.*, vol. 22, pp. 397-412 (2001).
- Cubeddu, Rinaldo, et al.; "Portable 8-channel time-resolved optical imager for functional studies of biological tissues," *Photon Migration, Optical Coherence Tomography, and Microscopy, Proceedings of SPIE*, vol. 4431, pp. 260-265 (2001).
- Cysewska-Sobusaik, Anna; "Metrological Problems With noninvasive Transillumination of Living Tissues," *Proceedings of SPIE*, vol. 4515, pp. 15-24 (2001).
- Earthrowl-Gould, T., et al.; "Chest and abdominal surface motion measurement for continuous monitoring of respiratory function," *Proc. Instn Mech Engrs*, V215, Part H; pp. 515-520 (2001).
- Gisiger, P.A., et al.; "OxiCarbo®, a single sensor for the non-invasive measurement of arterial oxygen saturation and CO₂ partial pressure at the ear lobe," *Sensor and Actuators*, vol. B-76, pp. 527-530 (2001).
- Gosney, S., et al.; "An alternative position for the pulse oximeter probe," *Anaesthesia*, vol. 56, p. 493 (2001).
- Kim, J.M., et al.; "Signal Processing Using Fourier & Wavelet Transform," pp. II-310-II-311 (2001).
- Lopez-Silva et al.; "NIR transmittance pulse oximetry system with laser diodes," *Clinical Diagnostic Systems, Proceedings of SPIE*, vol. 4255, pp. 80-87 (2001).
- Maletras, Francois-Xavier, et al.; "Construction and calibration of a new design of Fiber Optic Respiratory Plethysmograph (FORP)," *Optomechanical Design and Engineering, Proceedings of SPIE*, vol. 4444, pp. 285-293 (2001).
- Hayes, Matthew J., et al.; "A New Method for Pulse Oximetry Possessing Inherent Insensitivity to Artifact," *IEEE Transactions on Biomedical Engineering*, vol. 48, No. 4, pp. 452-461 (Apr. 2001).
- Rhee, Sokwoo, et al.; "Artifact-Resistant, Power-Efficient Design of Finger-Ring Plethysmographic Sensor," *IEEE Transactions on Biomedical Engineering*, vol. 48, No. 7, pp. 795-805 (Jul. 2001).
- Asada, Harry H. et al., "A new ring sensor design for improved motion artifact reduction without circulatory interference," *Progress*

(56)

References Cited

OTHER PUBLICATIONS

- Report No. 3-3, Oct. 1, 2001-Mar. 31, 2002, MIT Home Automation and Healthcare Consortium, pp. 1-45.
- Chan, K.W., et al.; "17.3: Adaptive Reduction of Motion Artifact from Photoplethysmographic Recordings using a Variable Step-Size LMS Filter," *IEEE*, pp. 1343-1346 (2002).
- Gostt, R., et al.; "Pulse Oximetry Artifact Recognition Algorithm for Computerized Anaesthetic Records," *Journal of Clinical Monitoring and Computing Abstracts*, p. 471 (2002).
- Irie, A., et al.; "Respiration Monitors—Pulse Oximeters," *Neonatal Care*, vol. 15, No. 12, pp. 78-83 (2002) (Article in Japanese—contains English summary of article).
- J. Hayoz, et al.; "World's First Combined digital Pulse Oximetry and Carbon Dioxide Tension Ear Sensor", Abstracts, A6, p. S103. (2002).
- J. Huang, et al.; "Low Power Motion Tolerant Pulse Oximetry," Abstracts, A7, p. S103. (2002).
- Jopling, Michael W., et al.; "Issues in the Laboratory Evaluation of Pulse Oximeter Performance," *Anesth Analg*, vol. 94, pp. S62-S68 (2002).
- Koga, I., et al.; "Sigmoid colonic reflectance pulse oximetry and tonometry in a porcine experimental hypoperfusion shock model," *Acta Anaesthesiol Scand*, vol. 46, pp. 1212-1216 (2002).
- Lang, et al.; "Signal Identification and Quality Indicator™ for Motion Resistant Pulse Oximetry," Abstracts, A10, p. S105. (2002).
- Liu, Ying, et al.; "Sensor design of new type reflectance pulse oximetry," *Optics in Health Care and Biomedical Optics: Diagnostics and Treatment, Proceedings of SPIE*, vol. 4916, pp. 98-102 (2002).
- Lutter, N., et al.; "Accuracy of Noninvasive Continuous Blood Pressure; Measurement Utilising the Pulse Transit Time," *Journal of clinical Monitoring and Computing*, vol. 17, Nos. 7-8, pp. 469 (2002).
- Lutter, Norbert O., et al.; "False Alarm Rates of Three Third-Generation Pulse Oximeters in PACU, ICU and IABP Patients," *Anesth Analg*, vol. 94, pp. S69-S75 (2002).
- Pothisarn, W., et al.; "A non-invasive hemoglobin measurement based pulse oximetry," *Optics in Health Care and Biomedical Optics: Diagnostics and Treatment; Proceedings of SPIE*, vol. 4916; pp. 498-504 (2002).
- Shaltis, Phillip, et al.; "Implementation and Validation of a Power-Efficient, High-Speed Modulation Design for Wireless Oxygen Saturation Measurement Systems," *IEEE*, pp. 193-194 (2002).
- Tobata, H., et al.; "Study of Ambient Light Affecting Pulse Oximeter Probes," *Ikigaku (Medical Technology)*, vol. 71, No. 10, pp. 475-476 (2002) (Article in Japanese—contains English summary of article).
- Tremper, K.K.; "A Second Generation Technique for Evaluating Accuracy and Reliability of Second Generation Pulse Oximeters," *Journal of Clinical Monitoring and Computing*, vol. 16, pp. 473-474 (2002).
- Yamaya, Yoshiki, et al.; "Validity of pulse oximetry during maximal exercise in normoxia, hypoxia, and hyperoxia," *J. Appl. Physiol.*, vol. 92, pp. 162-168 (2002).
- Yoon, Gilwon, et al.; Multiple diagnosis based on Photoplethysmography: hematocrit, SpO₂, pulse and respiration, *Optics in Health Care and Biomedical Optics: Diagnostics and Treatment; Proceedings of the SPIE*, vol. 4916; pp. 185-188 (2002).
- Gehring, Harmut, et al.; "The Effects of Motion Artifact and Low Perfusion on the Performance of a New Generation of Pulse Oximeters in Volunteers Undergoing Hypoxemia," *Respiratory Care*, Vol. 47, No. 1, pp. 48-60 (Jan. 2002).
- Kyriacou, P. A., et al.; "Investigation of oesophageal photoplethysmographic signals and blood oxygen saturation measurements in cardiothoracic surgery patients," *Physiological Measurement*, vol. 23, No. 3, pp. 533-545 (Aug. 2002).
- Ericson, M.N., et al.; "In vivo application of a minimally invasive oximetry based perfusion sensor," *Proceedings of the Second Joint EMBS/BMES Conference*, Houston, Texas; Oct. 23-26, 2002, pp. 1789-1790.
- Hase, Kentaro, et al.; "Continuous Measurement of Blood Oxygen Pressure Using a Fiber Optic Sensor Based on Phosphorescence Quenching," *Proceedings of the Second Joint EMBS/BMES Conference*, Houston, Texas; Oct. 23-26, 2002, pp. 1777-1778.
- Relente, A.R., et al.; "Characterization and Adaptive Filtering of Motion Artifacts in Pulse Oximetry using Accelerometers," *Proceedings of the Second joint EMBS/BMES Conference*, Houston, Texas, Oct. 23-26, 2002; pp. 1769-1770.
- Warren, Steve, et al.; "Wearable Sensors and Component-Based Design for Home Health Care," *Proceedings of the Second Joint EMBS/BMES Conference*, Houston, Texas; Oct. 23-26, 2002; pp. 1871-1872.
- Yao, Jianchu, et al.; "Design of a Plug-and-Play Pulse Oximeter," *Proceedings of the Second Joint EMBS/BMES Conference*, Houston, Texas, Oct. 23-26, 2002; pp. 1752-1753.
- Kyriacou, Panayiotis A., et al.; "Esophageal Pulse Oximetry Utilizing Reflectance Photoplethysmography," *IEEE Transactions on Biomedical Engineering*, vol. 49, No. 11, pp. 1360-1368 (Nov. 2002).
- Aoyagi, Takuo; "Pulse oximetry: its invention, theory, and future," *Journal of Anesthesia*, vol. 17, pp. 259-266 (2003).
- Avidan, A.; "Pulse oximeter ear probe," *Anesthesia*, vol. 58, pp. 726 (2003).
- Itoh, K., et al.; "Pulse Oximeter," *Toyaku Zasshi (Toyaku Journal)*, vol. 25, No. 8, pp. 50-54 (2003) (Article in Japanese—contains English summary of article).
- Johansson, A.; "Neural network for photoplethysmographic respiratory rate monitoring," *Medical & Biological Engineering & Computing*, vol. 41, pp. 242-248 (2003).
- Kubota, H., et al.; "Simultaneous Monitoring of PtcCO₂ and SpO₂ using a Miniature earlobe sensor," *Jinko Kogyo (Artificial Respiration)*, vol. 20, No. 1, pp. 24-29 (2003).
- Matsui, A., et al.; "Pulse Oximeter," *Neonatal Care*, vol. 16, No. 3, pp. 38-45 (2003) (Article in Japanese—contains English summary of article).
- Matthews, Nora S. et al.; "An evaluation of pulse oximeters in dogs, cats and horses," *Veterinary Anaesthesia and Analgesia*, vol. 30, pp. 3-14 (2003).
- Nakagawa, M., et al.; "Oxygen Saturation Monitor," *Neonatal Monitoring*, vol. 26, No. 5, pp. 536-539 (2003) (Article in Japanese—contains English summary of article).
- Pujary, C., et al.; "Photodetector Size Considerations in the Design of a Noninvasive Reflectance Pulse Oximeter for Telemedicine Applications," *IEEE*, pp. 148-149 (2003).
- Östmark, Åke, et al.; "Mobile Medical Applications Made Feasible Through Use of EIS Platforms," *IMTC—Instrumentation and Measurement Technology Conference*, Vail, Colorado; May 20-22, 2003; pp. 292-295.
- Stetson, Paul F.; "Determining Heart Rate from Noisy Pulse Oximeter Signals Using Fuzzy Logic," *The IEEE International Conference on Fuzzy Systems*, St. Louis, Missouri, May 25-28, 2003; pp. 1053-1058.
- Lopez-Silva et al.; "Near-infrared transmittance pulse oximetry with laser diodes," *Journal of Biomedical Optics*, vol. 8, No. 3, pp. 525-533 (Jul. 2003).
- Cyrill, D., et al.; "Adaptive Comb Filter for Quasi-Periodic Physiologic Signals," *Proceedings of the 25th Annual International Conference of the IEEE EMBS*, Cancun, Mexico, Sep. 17-21, 2003; pp. 2439-2442.
- Lebak, J.W., et al.; "Implementation of a Standards-Based Pulse Oximeter on a Wearable, Embedded Platform," *Proceeding of the 25th Annual International Conference of the IEEE EMBS*, Cancun, Mexico, Sep. 17-21, 2003; pp. 3196-3198.
- Mendelson, Y., et al.; "Measurement Site and Photodetector Size Considerations in Optimizing Power Consumption of a Wearable Reflectance Pulse Oximeter," *Proceedings of the 25th Annual International conference of the IEEE EMBS*, Cancun, Mexico, Sep. 17-21, 2003; pp. 3016-3019.
- Nagl, L., et al.; "Wearable Sensor System for Wireless State-of-Health Determination in Cattle," *Proceeding of the 25th Annual International Conference of the IEEE EMBS*, Cancun, Mexico, Sep. 17-21, 2003; pp. 3012-3015.

(56)

References Cited

OTHER PUBLICATIONS

Warren, Steve, et al.; "A Distributed Infrastructure for Veterinary Telemedicine," *Proceedings of the 25th Annual International Conference of the IEEE EMBS*, Cancun, Mexico; Sep. 17-21, 2003; pp. 1394-1397.

Lee, C.M., et al.; "Reduction of Motion Artifacts from Photoplethysmographic Recordings Using Wavelet Denoising Approach," *IEEE EMBS Asian-Pacific Conference on Biomedical Engineering*, Oct. 20-22, 2003; pp. 194-195.

Addison, Paul S., et al.; "A novel time-frequency-based 3D Lissajous figure method and its application to the determination of oxygen saturation from the photoplethysmogram," *Institute of Physics Publishing, Meas. Sci. Technol.*, vol. 15, pp. L15-L18 (2004).

Branche, Paul C., et al.; "Measurement Reproducibility and Sensor Placement Considerations in Designing a Wearable Pulse Oximeter for Military Applications," 2 pgs. (2004).

Crespi, F., et al.; "Near infrared oximeter prototype for non-invasive analysis of rat brain oxygenation," *Optical Sensing, Proceedings of SPIE*, vol. 5459, pp. 38-45 (2004).

Heuss, Ludwig T., et al.; "Combined Pulse Oximetry / Cutaneous Carbon dioxide Tension Monitoring During Colonoscopies: Pilot study with a Smart Ear Clip," *Digestion*, vol. 70, pp. 152-158 (2004).

Johnston, W. S., et al.; "Effects of Motion Artifacts on helmet-mounted Pulse Oximeter Sensors," 2 pgs. (2004).

Kocher, Serge, et al.; "Performance of a Digital PCO₂/SPO₂ Ear Sensor," *Journal of Clinical Monitoring and Computing*, vol. 18, pp. 75-79 (2004).

Mannheimer, Paul D., et al.; "The influence of Larger Subcutaneous Blood Vessels on Pulse Oximetry," *Journal of Clinical Monitoring and Computing*, vol. 18, pp. 179-188 (2004).

Nuhr, M., et al.; "Forehead SpO₂ monitoring compared to finger SpO₂ recording in emergency transport," *Anaesthesia*, vol. 59, pp. 390-393 (2004).

Reuss, James L.; "Factors Influencing Fetal Pulse Oximetry Performance," *Journal of Clinical Monitoring and Computing*, vol. 18, pp. 13-14 (2004).

Spigulis, Janis, et al.; "Optical multi-channel sensing of skin blood pulsations," *Optical Sensing, Proceedings of SPIE*, vol. 5459, pp. 46-53 (2004).

Sugino, Shigekzau, et al.; "Forehead is as sensitive as finger pulse oximetry during general anesthesia," *Can J. Anesth., General Anesthesia*, vol. 51, No. 5; pp. 432-436 (2004).

Urquhart, C., et al.; "Ear probe pulse oximeters and neonates," *Anaesthesia*, vol. 60, p. 294 (2005).

Wendelken, Suzanne, et al.; "The Feasibility of Using a Forehead Reflectance Pulse Oximeter for Automated Remote Triage," *IEEE*, pp. 180-181 (2004).

Lopez-Silva, S.M., et al.; "Transmittance Photoplethysmography and Pulse Oximetry With Near Infrared Laser Diodes," *IMTC 2004—Instrumentation and Measurement Technology Conference*, Como, Italy, May 18-20, 2004; pp. 718-723.

Matsuzawa, Y., et al.; "Pulse Oximeter," *Home Care Medicine*, pp. 42-45 (Jul. 2004); (Article in Japanese—contains English summary of article).

Johnston, W.S., et al.; "Extracting Breathing Rate Information from a Wearable Reflectance Pulse Oximeter Sensor," *Proceedings of the 26th Annual International conference of the IEEE EMBS*, San Francisco, California; Sep. 1-5, 2004; pp. 5388-5391.

Jovanov, E., et al.; "Reconfigurable intelligent Sensors for Health Monitoring: A case Study of Pulse Oximeter Sensor," *Proceedings of the 26th Annual International conference of the IEEE EMBS*, San Francisco, California, Sep. 1-5, 2004, pp. 4759-4762.

Yao, Jianchu, et al.; "A Novel Algorithm to Separate Motion Artifacts from Photoplethysmographic Signals Obtained With a Reflectance Pulse Oximeter," *Proceedings of the 26th Annual International conference of the IEEE EMBS*, San Francisco, California, Sep. 1-5, 2004; pp. 2153-2156.

Yan, Yong-sheng, et al.; "Reduction of motion artifact in pulse oximetry by smoothed pseudo Wigner-Ville distribution," *Journal of NeuroEngineering and Rehabilitation*, vol. 2, No. 3 (9 pages) (Mar. 2005).

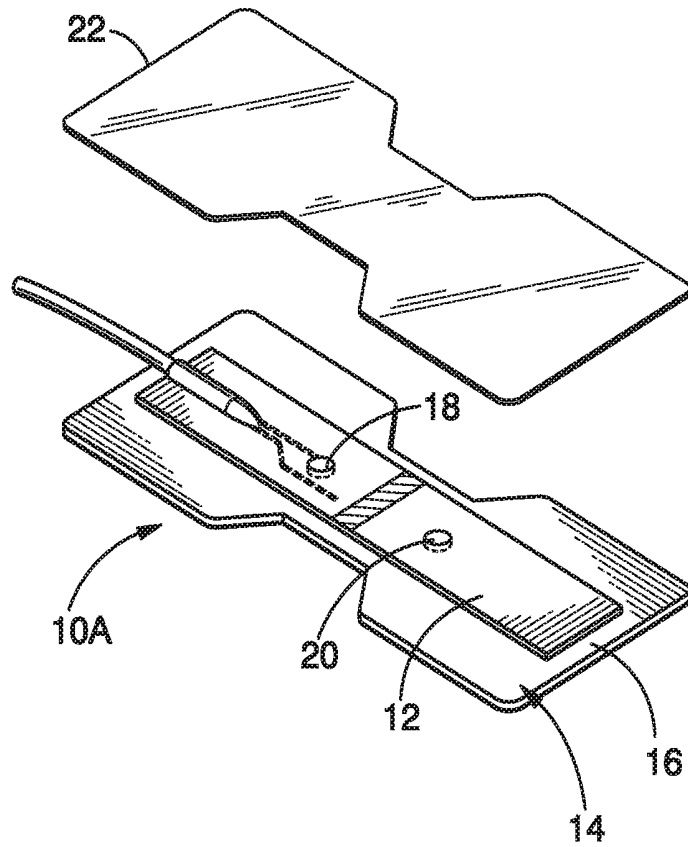

FIG. 1

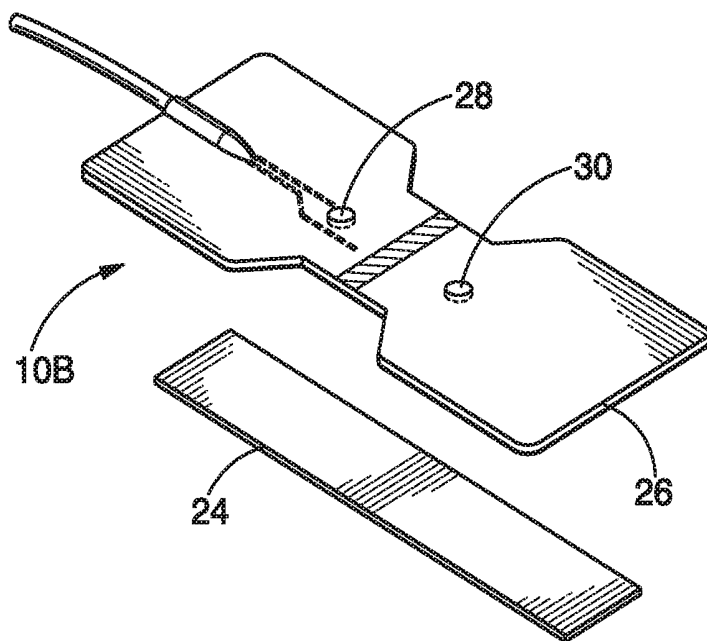
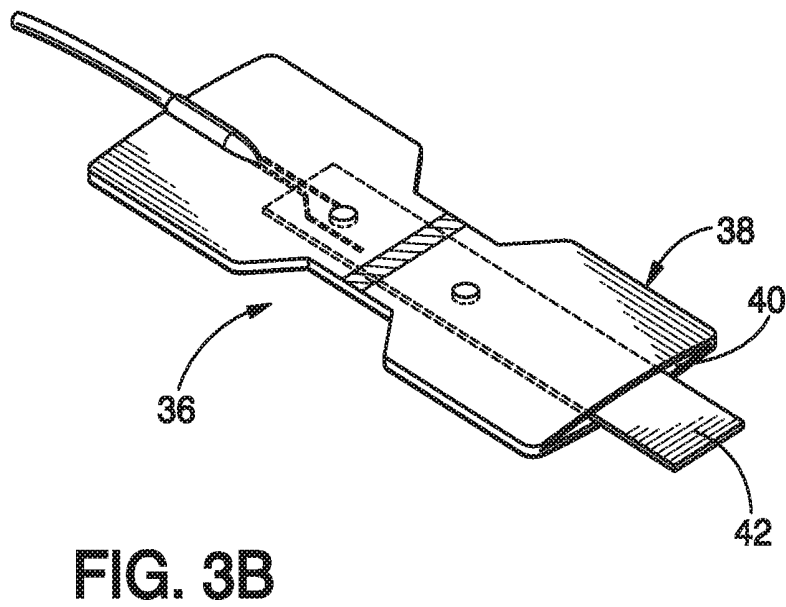
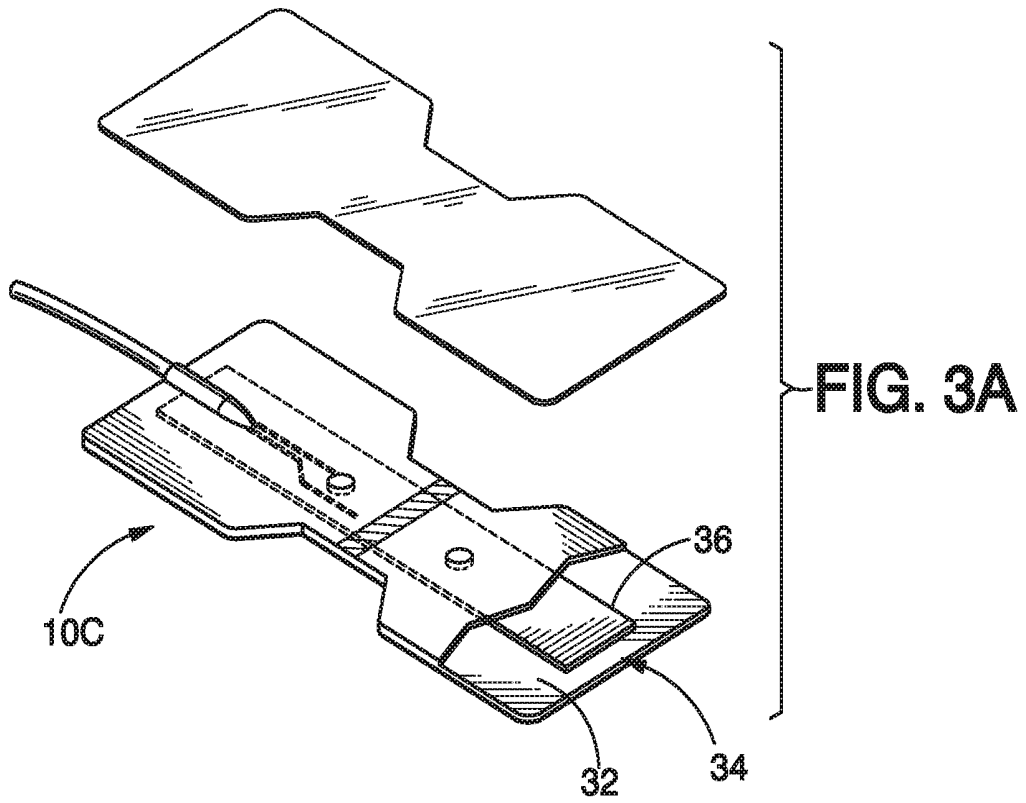
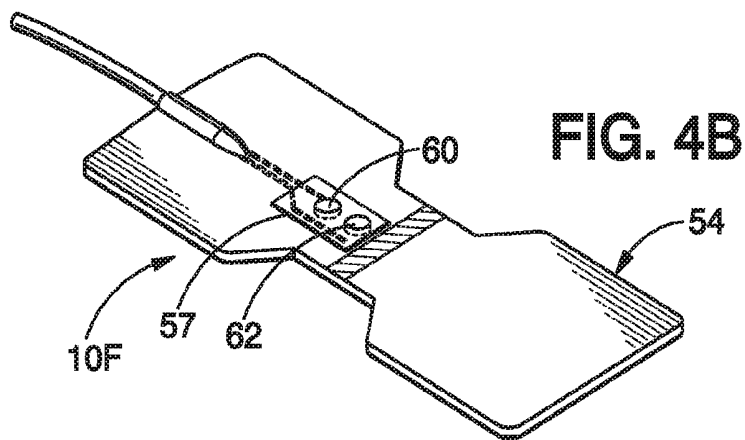
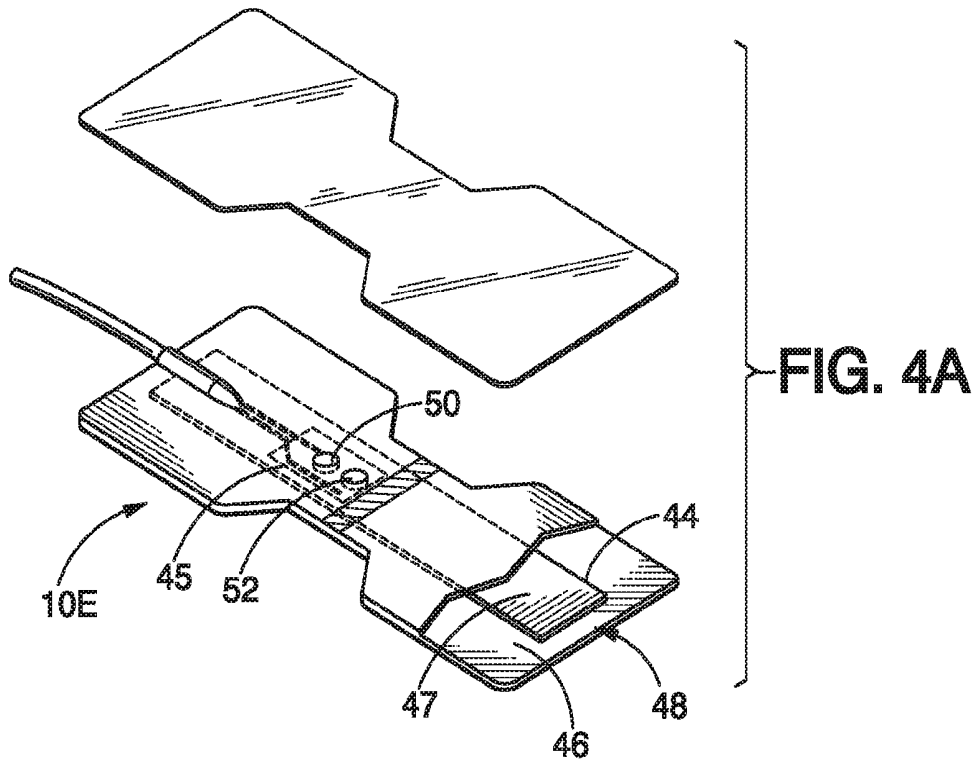
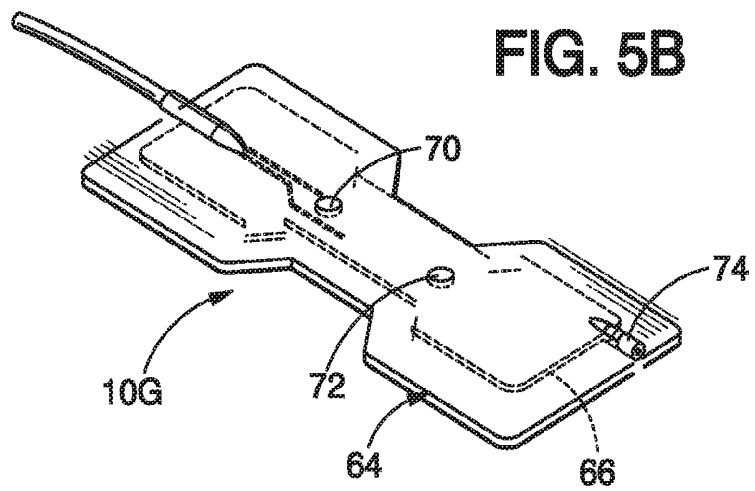
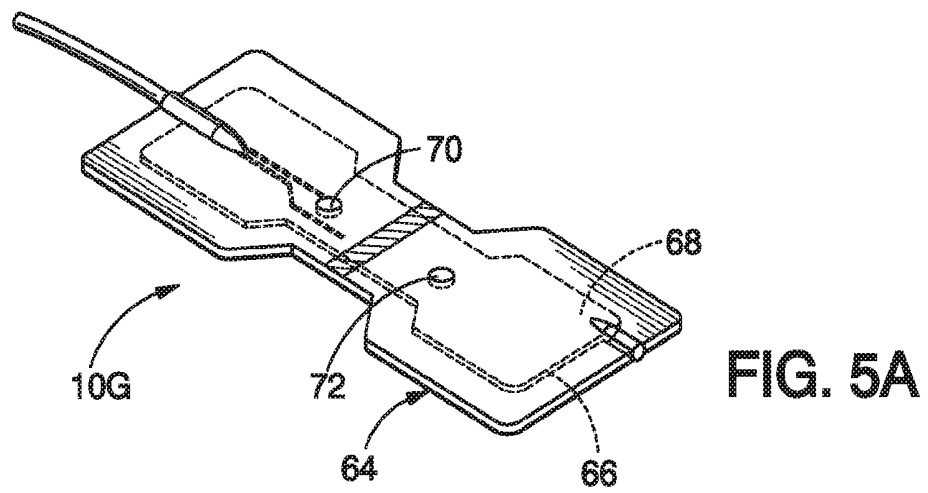
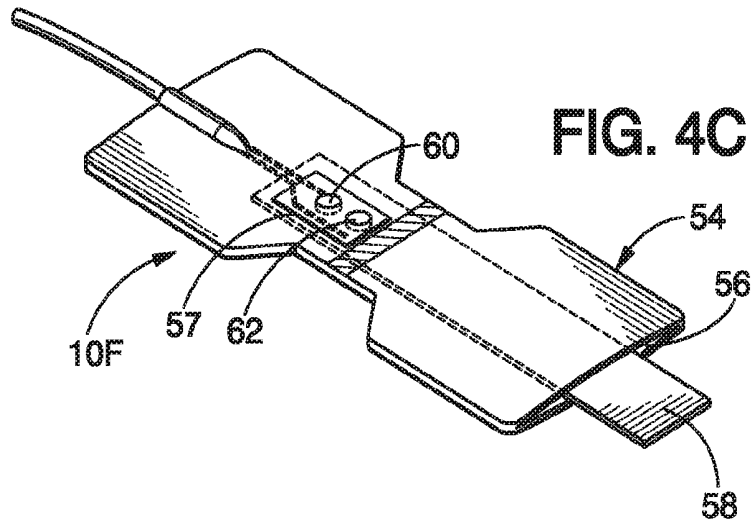
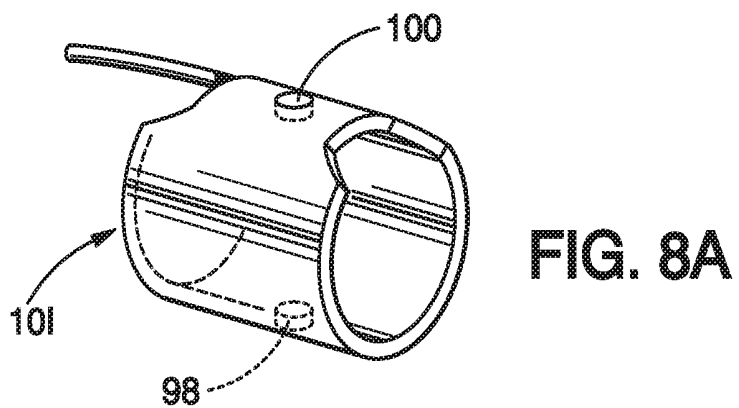
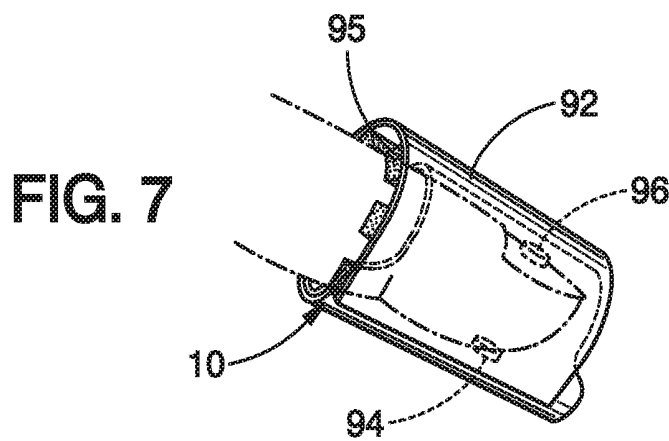
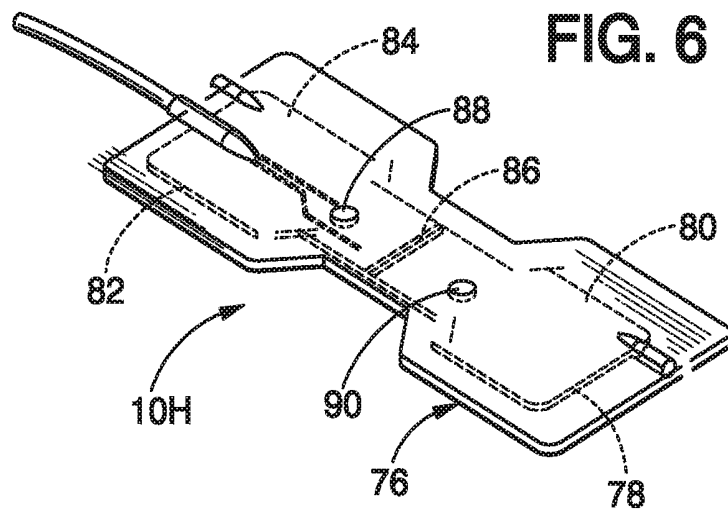

FIG. 2









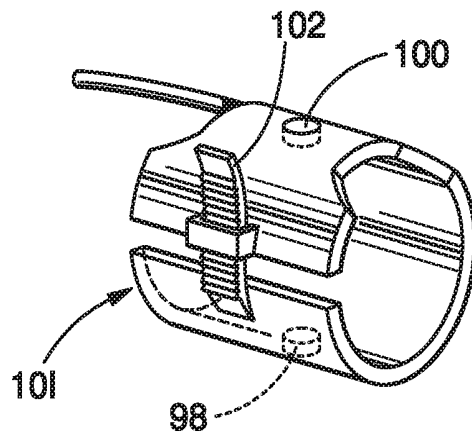

FIG. 8B

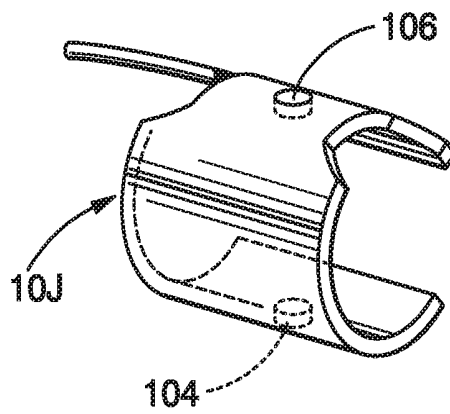

FIG. 9

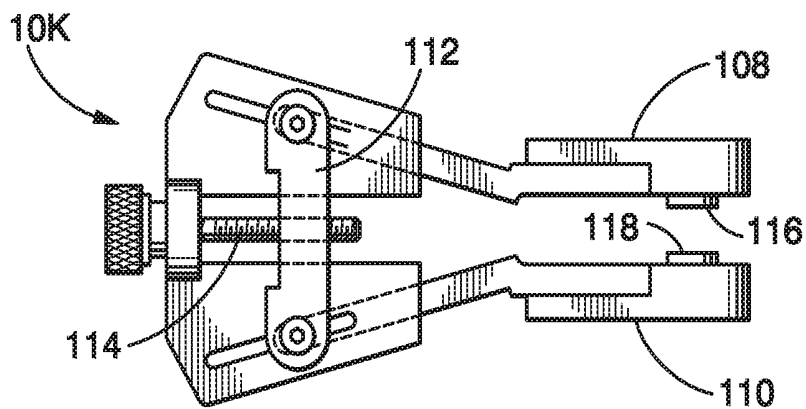

FIG. 10

FIG. 11A

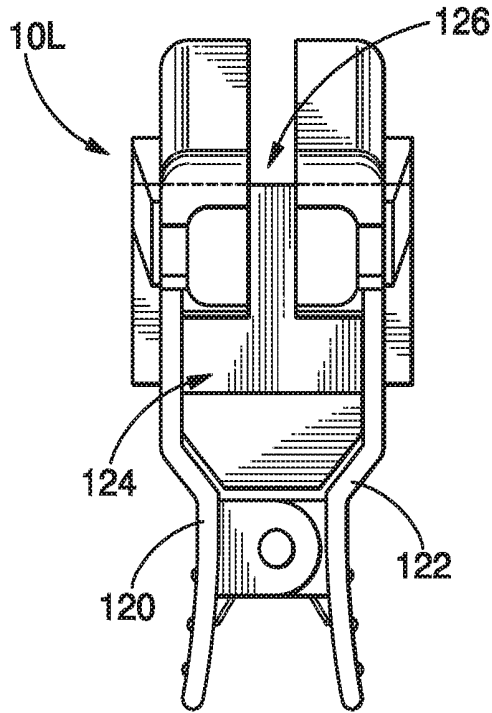

FIG. 11B

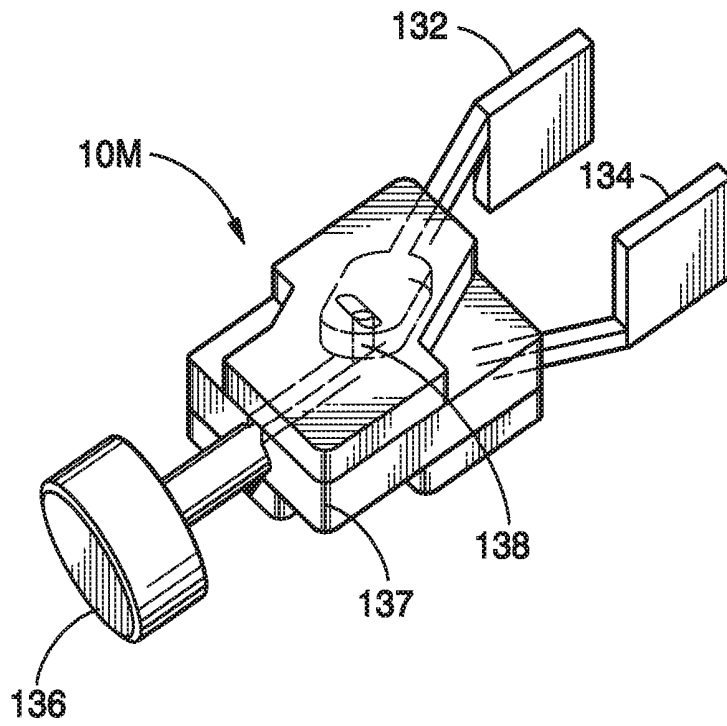
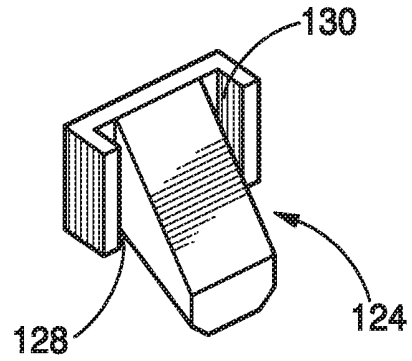
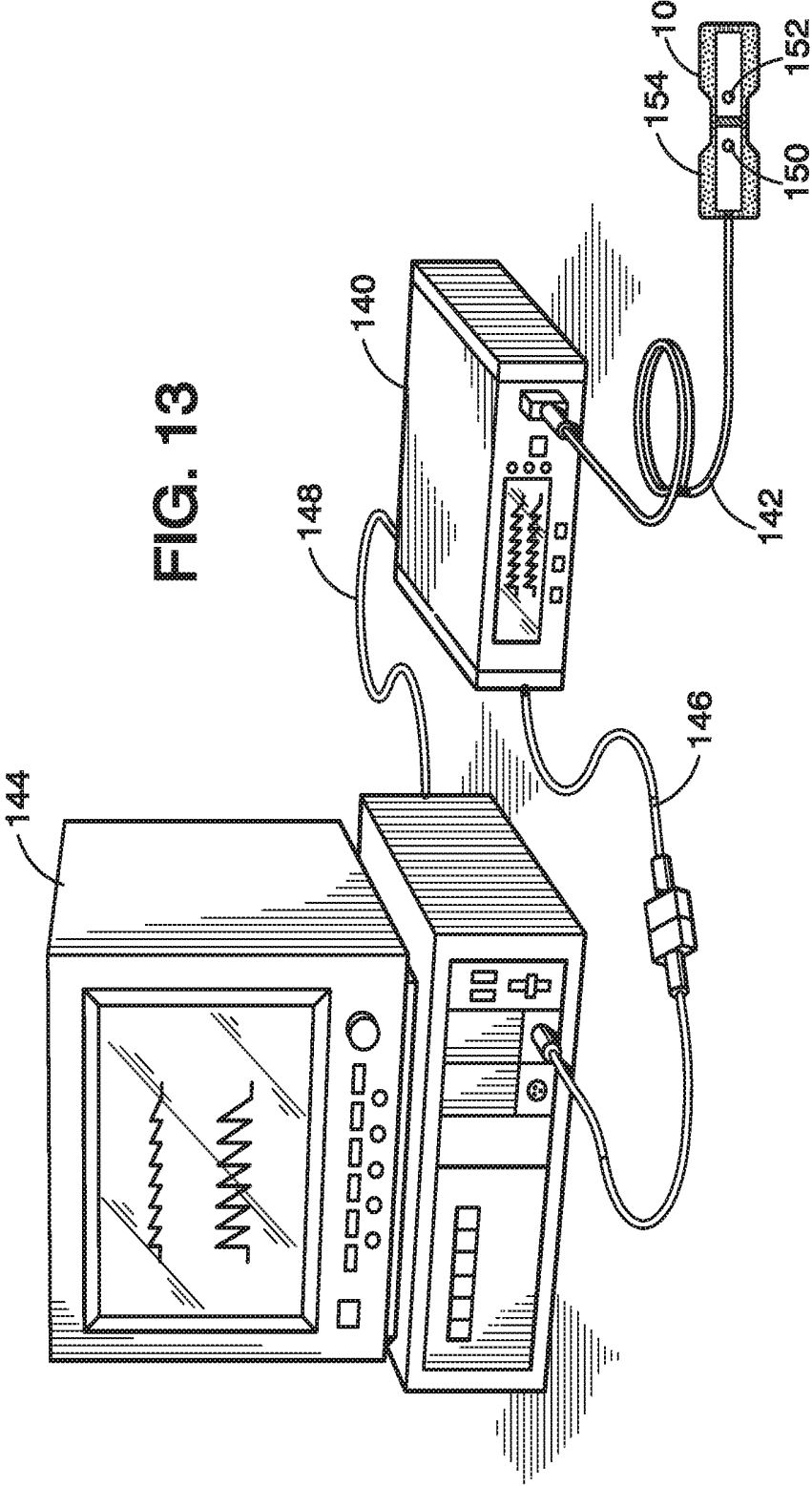

FIG. 12



MEDICAL SENSOR FOR REDUCING MOTION ARTIFACTS AND TECHNIQUE FOR USING THE SAME

CROSS-REFERENCE TO RELATED APPLICATION

This application is a continuation of U.S. patent application Ser. No. 11/497,089, filed Aug. 1, 2006, which is a continuation of U.S. patent application Ser. No. 11/241,375, filed Sep. 29, 2005, now U.S. Pat. No. 7,869,850, the disclosures of which are hereby incorporated by reference in their entirety.

BACKGROUND OF THE INVENTION

1. Field of the Invention

The present invention relates generally to medical devices and, more particularly, to sensors used for sensing physiological parameters of a patient.

2. Description of the Related Art

This section is intended to introduce the reader to various aspects of art that may be related to various aspects of the present invention, which are described and/or claimed below. This discussion is believed to be helpful in providing the reader with background information to facilitate a better understanding of the various aspects of the present invention. Accordingly, it should be understood that these statements are to be read in this light, and not as admissions of prior art.

In the field of medicine, doctors often desire to monitor certain physiological characteristics of their patients. Accordingly, a wide variety of devices have been developed for monitoring many such characteristics of a patient. Such devices provide doctors and other healthcare personnel with the information they need to provide the best possible healthcare for their patients. As a result, such monitoring devices have become an indispensable part of modern medicine.

One technique for monitoring certain physiological characteristics of a patient is commonly referred to as pulse oximetry, and the devices built based upon pulse oximetry techniques are commonly referred to as pulse oximeters. Pulse oximetry may be used to measure various blood flow characteristics, such as the blood-oxygen saturation of hemoglobin in arterial blood, the volume of individual blood pulsations supplying the tissue, and/or the rate of blood pulsations corresponding to each heartbeat of a patient. In fact, the "pulse" in pulse oximetry refers to the time varying amount of arterial blood in the tissue during each cardiac cycle.

Pulse oximeters typically utilize a non-invasive sensor that transmits electromagnetic radiation, such as light, through a patient's tissue and that photoelectrically detects the absorption and scattering of the transmitted light in such tissue. One or more of the above physiological characteristics may then be calculated based upon the amount of light absorbed and scattered. More specifically, the light passed through the tissue is typically selected to be of one or more wavelengths that may be absorbed and scattered by the blood in an amount correlative to the amount of the blood constituent present in the tissue. The measured amount of light absorbed and scattered may then be used to estimate the amount of blood constituent in the tissue using various algorithms.

Pulse oximetry readings measure the pulsatile, dynamic changes in amount and type of blood constituents in tissue. Other events besides the pulsing of arterial blood may lead to modulation of the light path, direction, and the amount of light detected by the sensor, creating error in these measurements. Pulse oximetry is sensitive to movement, and various

types of motion may cause artifacts that may obscure the blood constituent signal. For example, motion artifacts may be caused by moving a sensor in relation to the tissue, by increasing or decreasing the physical distance between emitters and detectors in a sensor, by changing the direction of emitters or detectors with respect to tissue or each other, by changing the angles of incidence and interfaces probed by the light, by directing the optical path through different amounts or types of tissue, or by expanding, compressing or otherwise altering tissue near a sensor. In the emergency room, critical care, intensive care, and trauma center settings, where pulse oximetry is commonly used for patient monitoring, the wide variety of sources of motion artifacts includes moving of a patient or the sensor by healthcare workers, physical motion of an unanaesthetised or ambulatory patient, shivering, seizures, agitation, response to pain and loss of neural control. These motions oftentimes have similar frequency content to the pulse, and may lead to similar or even larger optical modulations than the pulse.

Two categories of pulse oximetry sensors in common use may be classified by their pattern of use: the disposable and the reusable sensor. Disposable sensors are typically flexible bandage-type structures that may be attached to the patient with adhesive materials, providing a contact between the patient's skin and the sensor components. Disposable sensors have multiple advantages, including ease of conformation to the patient. The flexible nature of disposable sensors further renders them susceptible to motion artifacts caused by mechanical deformation of the sensor, which changes the amount of light detected. Reusable sensors, often semi-rigid or rigid clip-type devices, are also vulnerable to motion artifacts, such as artifacts caused by partial opening of the clip in response to patient motion. Both categories of sensors may have modulations of detected light induced by the physical motion of the sensor components with respect to each other and the tissue.

Motion artifacts may sometimes be addressed by signal processing and filtering to mitigate the effects of motion after the motion has occurred. However, it would be desirable to provide a sensor that reduces the occurrence of movement that may lead to motion artifacts.

SUMMARY

Certain aspects commensurate in scope with the originally claimed invention are set forth below. It should be understood that these aspects are presented merely to provide the reader with a brief summary of certain forms of the invention might take and that these aspects are not intended to limit the scope of the invention. Indeed, the invention may encompass a variety of aspects that may not be set forth below.

There is provided a sensor that includes a sensor body, and an emitter and a detector disposed on the sensor body. The sensor body is adapted to hold the emitter and detector at a substantially fixed optical distance relative to one another when the sensor is applied to a patient.

There is also provided a pulse oximetry system that includes a pulse oximetry monitor and a pulse oximetry sensor adapted to be operatively coupled to the monitor. The sensor includes a sensor body, and an emitter and a detector disposed on the sensor body. The sensor body is adapted to hold the emitter and detector at a substantially fixed optical distance relative to one another when the sensor is applied to a patient.

There is also provided a method of operating a sensor that includes fixing the optical distance between an emitter and a

detector relative to one another, whereby the emitter and the detector are disposed on a sensor body.

There is also provided a method of manufacturing a sensor that includes providing a sensor body on which an emitter and a detector are disposed, whereby the sensor body is adapted to hold the emitter and the detector at a fixed optical distance.

BRIEF DESCRIPTION OF THE DRAWINGS

Advantages of the invention may become apparent upon reading the following detailed description and upon reference to the drawings in which:

FIG. 1 illustrates a perspective view of an exemplary bandage-style pulse oximetry sensor with a stiffening member on the tissue-contacting side of the sensor body;

FIG. 2 illustrates a perspective view of an exemplary bandage-style pulse oximetry sensor with a brass stiffening member applied to the surface of the sensor body that does not contact a patient's tissue during normal use;

FIG. 3A illustrates a view showing the interior of an exemplary bandage-style pulse oximetry sensor with an embedded stiffening member;

FIG. 3B illustrates a perspective view of an exemplary bandage-style pulse oximetry sensor with an embedded, removable stiffening member;

FIG. 4A illustrates a view showing the interior of an exemplary reflectance bandage-style pulse oximetry sensor with an embedded stiffening member including a rigid portion that surrounds the emitter and the detector and a flexible portion;

FIG. 4B illustrates a view showing an exemplary reflectance bandage-style pulse oximetry sensor with a stiffening member surrounding the emitter and detector;

FIG. 4C illustrates a perspective view of an exemplary reflectance bandage-style pulse oximetry sensor with a rigid portion that surrounds the emitter and the detector and an embedded, removable stiffening member that is flexible;

FIG. 5A illustrates a perspective view of an exemplary bandage-style pulse oximetry sensor with a fluid-filled chamber;

FIG. 5B illustrates a perspective view of the pulse oximetry sensor of FIG. 5A in which the fluid-filled chamber includes a valve;

FIG. 6 illustrates a perspective view of an exemplary bandage-style pulse oximetry sensor with two fluid-filled chambers separated by a breakable barrier;

FIG. 7 illustrates a perspective view of an exemplary pulse oximetry sensor according to the present invention with a removable rigid sleeve;

FIG. 8A illustrates a perspective view of an exemplary annular pulse oximetry sensor according to the present invention;

FIG. 8B illustrates a perspective view of the pulse oximetry sensor of FIG. 8A with an adjustment strap;

FIG. 9 illustrates an embodiment of an exemplary partially annular pulse oximetry sensor according to the present invention;

FIG. 10 illustrates a cross-sectional view of an exemplary clip-style pulse oximetry sensor with a spacer that moves to adjust the distance between the two portions of the clip;

FIG. 11A illustrates a cross-sectional view of an exemplary clip-style pulse oximetry sensor with a removable spacer according to the present invention;

FIG. 11B is a perspective view of the removable spacer of FIG. 11A;

FIG. 12 illustrates a perspective view of an exemplary clip-style pulse oximetry sensor in which the two portions of the clip are adjusted with a sliding pin; and

FIG. 13 illustrates a pulse oximetry system coupled to a multi-parameter patient monitor and a sensor according to embodiments of the present invention.

DETAILED DESCRIPTION OF SPECIFIC EMBODIMENTS

One or more specific embodiments of the present invention will be described below. In an effort to provide a concise description of these embodiments, not all features of an actual implementation are described in the specification. It should be appreciated that in the development of any such actual implementation, as in any engineering or design project, numerous implementation-specific decisions must be made to achieve the developers' specific goals, such as compliance with system-related and business-related constraints, which may vary from one implementation to another. Moreover, it should be appreciated that such a development effort might be complex and time consuming, but would nevertheless be a routine undertaking of design, fabrication, and manufacture for those of ordinary skill having the benefit of this disclosure.

In accordance with the present technique, sensors for pulse oximetry or other applications utilizing spectrophotometry are provided that reduce motion artifacts by fixing the optical distance between an emitter and a detector when the sensor is applied to a patient. For example, in one embodiment, a conformable sensor is provided that has a stiffening member adapted to hold the emitter and detector at a fixed optical distance when the sensor is applied to a patient. In another embodiment, an annular or partially annular sensor is provided that maintains a fixed optical distance between an emitter and a detector when the sensor is applied to a patient's digit. Further, in an additional embodiment, a clip-style sensor is provided that holds the emitter and detector at a fixed optical distance.

Motion artifacts in pulse oximetry are often generated by the movement of the pulse oximetry sensor relative to the optically probed tissue, which is typically caused by patient movement. Because pulse oximetry is often used in settings where it is difficult to prevent patient motion, it is desirable to provide a mechanism for reducing the effects of motion on the pulse oximetry measurement. Generally, sensors are vulnerable to motion artifacts when the optical distance between a sensor's emitter and detector varies due to an undesired mechanical change in the conformation of the sensor while in use.

A change in optical distance may include any change in position or geometry of the emitter and/or the detector relative to the tissue or relative to each other. More specifically, a change in optical distance may involve a change in the path length, a change in the angle of the emitter or detector relative to one another, and/or a change in the angle of the emitter or detector relative to the tissue. For example, a tapping or pressing motion by a patient may serve to compress a flexible bandage sensor, decreasing the path length between the emitter and detector. Alternatively, a tapping or pressing motion may partially open a clip-type sensor through pressure on the clip spring, thus increasing the path length between the emitter and detector. For both a bandage and a clip-style sensor, a jerking or flexing motion may separate the emitter and detector, thus increasing the optical path length. Additionally, any of the above motions may twist or bend the sensor, causing the angle of the emitter and/or the detector to change relative to the sensor and each other. As sensors do not typically emit nor detect light omnidirectionally; any motions that lead to variations in angle of sensor components may alter the amount of light detected, and may force detected light through different

portions of tissue. In any case, variability in the optical path length due to motion can cause motion artifacts and obscure the desired pulse oximetry signal. Thus, it is desirable that a sensor's emitter and detector are held at a substantially fixed optical distance with respect to one another.

By holding a sensor's emitter and detector at a substantially fixed optical position with respect to one another, the sensors provided herein limit the modulations of detected light that may occur and the resulting measurement errors. These sensors substantially reduce the occurrence of motion artifacts by reducing the change in position of the sensing components of the sensor with respect to each other and the tissue.

Keeping in mind the preceding points, the following exemplary sensor designs are provided as examples of sensors that reduce motion artifacts by maintaining a fixed optical distance between an emitter and a detector of a sensor 10. It should be appreciated that a sensor 10 according to the present teachings may be adapted for use on any digit, and may also be adapted for use on a forehead, earlobe, or other sensor site. For example, a sensor 10 may be a clip-style sensor, appropriate for a patient earlobe or digit. Alternatively, a sensor 10 may be a bandage-style or wrap-style sensor for use on a digit or forehead. Further, it should be appreciated that a sensor 10 may also include adhesives to facilitate securing of the sensing elements to the tissue. In certain embodiments, the adhesives may include an adhesive coating on the tissue-contacting surface of the sensor 10.

In accordance with some embodiments of the present technique, sensors for pulse oximetry or other applications utilizing spectrophotometry are provided having a stiffening member to reduce variability in the optical distance between an emitter and a detector. For example, FIG. 1A illustrates an exemplary transmission-type bandage sensor appropriate for use on a patient digit. As shown in FIG. 1A, a sensor 10A may have a stiffening member 12 that is applied to a conformable sensor body 14. The stiffening member 12 may be applied to a tissue-contacting surface 16, adhesively or otherwise. As the stiffening member 12 may come into contact with a patient's tissue, it may be generally constructed to have no sharp edges in order to avoid patient discomfort. The stiffening member 12 may have windows or other openings (not shown) suitably sized to accommodate an emitter 18 and a detector 20. The stiffening member 12 may applied such that the windows or openings are in-line with the emitter and the detector to allow for normal light emitting and photodetecting function. The sensor 10A may optionally include an optically transparent adhesive layer 22 for affixing the sensor to the digit. The adhesive layer 22 may be generally sized and shaped to cover the tissue-contacting surface 16 of the conformable sensor body 22. When the sensor 10A is applied to a patient's digit, the stiffening member is bent or otherwise shaped to conform to the digit. The sensor 10A is applied such that the emitter 18 and the detector 20 lie on opposing side of the digit. After application of the sensor 10A, the emitter 18 and the detector 20 are substantially resistant to movement relative to one another.

The stiffening member 12 (and stiffening members 36 and 42, below) may be constructed from any suitable material that functions to hold the emitter and the detector of a sensor at a substantially fixed optical distance when the sensor 10A is applied to a patient. For example, a suitable stiffening member 12 may be metal, plastic or polymeric, or cardboard. In certain embodiments, suitable metals include aluminum or brass. The stiffening member 12 may be in the shape of a strip, wire, or mesh that can be easily adapted for use with a conformable sensor body 14. The stiffening member 12 may

adapted to be easily bent, shaped, activated, or applied to a conformable sensor body 14 in order to hold an emitter and a detector at a substantially fixed optical distance. The stiffening member 12 may be sized to substantially cover a majority of the tissue-contacting surface 16, or for reasons related to cost or total sensor weight, may be sized to form a strip that is generally in the area surrounding the emitter 18 and the detector 20.

In certain embodiments, it may be advantageous to apply a stiffening member to a sensor surface that does not contact a patient's tissue during normal use. For example, certain patients may be sensitive to metals, and thus in certain circumstances it may be desirable to limit the amount of skin contact with a metal stiffening member. For those patients, a sensor 10B as shown in FIG. 2 may be appropriate. FIG. 2 shows an embodiment of a sensor 10B in which a brass stiffening member 24 is applied to a surface 26 that does not contact the tissue during normal use of the sensor 10B. The brass stiffening member 24 is applied to the surface 26 along an imaginary axis connecting an emitter 28 and a detector 30. When the sensor 10B is applied to a patient's digit, the brass stiffening member 24 is bent to conform to the digit without coming in contact with the patient's tissue. In an alternate embodiment (not shown), the sensor 10B is adapted to operate in reflectance mode. The emitter 28 and detector 30 are positioned on the sensor body such that they lay side-by-side when applied to a patient's digit.

In certain embodiments, a stiffening member may be integrally constructed with the conformable sensor body, or may be a separate structure. More specifically, in the embodiment shown in FIG. 3A, a sensor 10C has a closed cavity 32 within the conformable sensor body 34 into which a stiffening member 36 may be integrated or embedded. Alternatively, in certain embodiments, it may be advantageous to apply the stiffening member to the sensor at the time of use. FIG. 3B illustrates sensor 10D in which the conformable sensor body 38 has an open cavity 40 that extends along the sensor body to provide an opening into which a removable stiffening member 42 may be manually inserted at the time of application of the sensor 10D to a patient. Before the sensor 10D is discarded after use, the removable stiffening member 42 may be removed and stored for reuse. Having a removable stiffening member 42 that is reusable is not integral to the sensor 10D may decrease sensor weight for shipping and transport, and thus may provide certain cost advantages.

In an alternate embodiment shown in FIG. 4A, a sensor 10E with an embedded stiffening member 44 within a closed cavity 46 in the conformable sensor body 48 may be adapted to operate in reflectance mode, such the emitter 50 and the detector 52 lie side-by-side when the sensor is applied to a patient. The stiffening member 44 includes a rigid portion 45 disposed in the area adjacent to the emitter 50 and the detector 52 and a more flexible portion 47. Thus, when the sensor 10E is applied to a patient, the flexible portion 47 of the stiffening member 44 allows the sensor 10E to be bent around a digit while adding stability to the conformable sensor body 48. The rigid portion 45 surrounding the emitter 50 and the detector 52 may fix the geometry of sensing elements, substantially reducing their ability to move relative to one another. In an alternate embodiment, FIG. 4B illustrates reflectance sensor 10F in which the conformable sensor body 54 includes a rigid portion 57 that surrounds the emitter 60 and the detector 62. The rigid portion may be embedded in the sensor body 54, or may be disposed on the tissue-contacting surface of the sensor body 54. FIG. 4C illustrates an alternate embodiment of the sensor 10F in which the conformable sensor body 54 has an open cavity 56 that extends along the sensor body to provide

an opening into which a flexible member **58** may be manually inserted at the time of application of the sensor **10F** to a patient. The rigid portion **57** is separate from the removable flexible member **58**. Thus, if a healthcare worker feels that additional sensor **10F** stability may be advantageous, the flexible member **58** may be inserted into the sensor **10F**. When the sensor is applied to the patient, the emitter **60** and the detector **62** lie side-by-side on the same side of the tissue.

A stiffening member need not be solid, but may also be a fluid or other non-solid material that stabilizes the optical distance between an emitter and a detector. In another embodiment, FIG. **5A** shows a sensor **10G** in which the conformable sensor body **64** contains a bladder **66** that is adapted to hold a fluid **68**. The fluid **68** may be a liquid, gel, gas, or any suitable mixture thereof. It is contemplated that the stiffening qualities of a gas or liquid may be realized by achieving a certain pressure in the bladder **66**. Generally, it is contemplated that the bladder **66** should be fully inflated or mostly inflated with the fluid **68** to hold the emitter **70** and the detector **72** at a fixed optical distance. In certain embodiments, a liquid or gel may harden after a period of time. The fluid **66** described in the above embodiment may be any suitable fluid that acts to hold an emitter **70** and a detector **72** at a substantially fixed optical distance when the sensor **10G** is applied to a patient's digit. In certain embodiments, the fluid may be air or other gases and gas mixtures. In other embodiments, the fluid may be water.

In certain embodiments, it may be desirable employ a gas or gas mixture for reasons related to cost, manufacturing convenience, and total sensor weight. In FIG. **5B**, the sensor **10G** is modified to include a valve **74** or another suitable opening or gas injection site. The sensor may be applied to a patient's digit when the valve **74** is in the closed position and the bladder **66** is substantially empty and deflated. After application of the sensor **10G** to the digit, the valve **74** is opened to allow air to flow into the bladder **66**, which stiffens the sensor **10G** to fix the distance between the emitter **70** and the detector **72**. In other embodiments, the valve **74** may be a fluid or epoxy injection site.

Another embodiment in which a fluid-containing stiffening member may be activated upon application of the sensor to a patient is illustrated in FIG. **6**. FIG. **6** depicts a sensor **10H** with a first chamber **78** filled with a first material **80**, and second chamber **82** filled with a second material **84**. A barrier **86** separates the first chamber **78** and second chamber **82**. The barrier **86** is capable of being broken upon applying the sensor **82** to a patient. After the breaking of the barrier **86**, the first material **80** and the second material **84** will mix and form a composition that is capable of hardening, thus stabilizing the optical distance between the emitter **88** and detector **90**. For example, the first material **80** may be cement or plaster, and the second material **84** may be water. In another embodiment, the first material **80** may be epoxy. In another embodiment, the first material **80** may be one part of a two-part epoxy in which a first part of the epoxy, such as the base, is the first materials **80**, and a second part of the epoxy, such as the catalyst or hardener, is the second material **84**. Two part epoxies that may be used with a sensor **10H** include Loctite® 30680 (available from Henkel, Rocky Hill, Conn.), Blu-Mousse® (available from Parkell, Inc., Farmindale, N.Y.), LuxaCore® Smartmix dual from DMG (available from DMG, Englewood, N.J.), and Exaflex (available from GC America, Inc., Alsip, Ill.).

In alternate embodiments, a stiffening member may be conditionally activated when exposed to air or light, placed in contact with skin, attached to the sensor site, conformed to fit the sensor site, subjected to a specific environmental con-

dition (e.g., when exposed to body or room temperatures), subjected to a specific chemical reaction, programmed by software, or subjected to external force, (e.g., from the tissue being probed by the sensor). For example, a conditionally activated stiffening member may be a vacuum-packed polymer that forms a rigid precipitate upon exposure to oxygen or water vapor. In other embodiments, the stiffening member may include a light curing adhesive such as Loctite® Flash-cure-4305 (available from Henkel, Rocky Hill, Conn.). In another embodiment, the stiffening member may include a material undergoes a chemical hardening, such a crystallization upon exposure to a crystal seed. One such material is supersaturated sodium acetate solution that is exposed to a sodium acetate crystal. Other suitable materials for forming conditionally activated stiffening members include polyurethane and polystyrene foams that, for example, may expand and stiffen upon exposure to air.

FIG. **7** illustrates an alternate embodiment of the invention in which the stiffening member is a sleeve **92** that may be applied to a sensor, generically identified as a sensor **10**, in order to mechanically stabilize the distance between the emitter **94** and detector **96** after application of the sensor **10**. The sleeve **94** may have interior bumps or protrusions such as foam bumpers **95**, which serve to absorb shock and cushion the sensor **10** against external forces.

Although the previously discussed embodiments have described conformable sensors, it is also envisioned that similar advantages may be realized by configuring relatively rigid sensors to hold an emitter and a detector at a fixed optical distance. For example, FIG. **8A** shows a rigid annular sensor **10I** adapted to be applied to a patient's digit. The sensor **10I** is adapted to be slid onto a patient digit, and may be further secured by a bandage or adhesive. The rigidity of the sensor **10I** serves to hold the emitter **98** and the detector **100** at a fixed optical distance. In another embodiment (not shown), the sensor **10G** may open at a hinge and also have a latch, snap, or other closing mechanism. The annular sensor **10I** may be adjusted with a strap **102**, as shown in FIG. **8B**, or other adjustment mechanism in order to closely conform to the digit.

FIG. **9** shows a partially annular sensor **10J** that may be placed on a digit and self-secured or secured by a bandage or other means. The sensor **10J** is generally at least hemi-annular in order to provide sufficient grip on the digit. An emitter **104** and a detector **106** are arranged such that, when the sensor is applied to the digit, they would be on opposite sides of the digit.

The annular or partially annular sensors (e.g. sensors **10I** and **10J**) may be constructed from plastic, metal, cardboard, or any other suitable resilient material. It is contemplated the sensors **10I** and **10J** may be sized to approximately correlate to the profile of a jewelry ring. Alternatively, the sensors **10I** and **10J** may be sized to approximately correlate to the size of the first finger joint, such that when a sensor **10I** or **10J** is applied to the digit, the fingernail region of a digit is generally covered by the sensor, but the sensor does not interfere with flexing or bending of the finger joint.

In another embodiment, a reusable clip-style sensor adapted for use on either a digit or an earlobe is provided that holds an emitter and detector at a fixed optical distance with the use of a spacer. Such a sensor adapted for use on a patient earlobe is shown in FIG. **10**, which illustrates a sensor **10K** having a first portion **108** and a second portion **110** that may be moved towards one another or away from one another. The first portion **108** and the second portion **110** are each able to engage a spacer **112** that is controlled by a threaded pin **114**. The spacer **112** controls the distance between the first portion

88 and the second portion **110** as the threaded pin **114** moves the spacer **112** along an angled track. The first portion **108** has an emitter **116** disposed on the tissue-contacting surface and the second portion **110** has a detector **118** disposed on the tissue-contacting surface. When the sensor **10K** is applied an earlobe, the spacer **112** may be adjusted such that the sensor **10K** provides a desired amount of tension to the earlobe while maintaining a fixed optical distance between the first portion **108** and the second portion **110**.

An alternate embodiment of a clip-style sensor **10L** with a spacer is depicted in FIG. 11A. As shown, a first portion **120** and a second portion **122** of the sensor **10L** may be fixed in place after application to an earlobe with a removable spacer **124**. The removable spacer **124** slides into a space **106** between the first portion **120** and the second portion **122** and prevents the first portion **120** and the second portion **122** from moving relative to one another. As shown in FIG. 11B, the removable spacer has grooves **128** and **130** into which suitably sized regions of the first portion **120** and the second portion **122** may slide. When the first portion **120** and the second portion **122** are fixed in grooves **128** and **130**, they are unable to move relative to one another. The removable spacer **124** is shown with an angled profile, but may be shaped or sized in any suitable configuration that serves to hold the first portion **120** and the second portion **122** at a fixed optical distance when the spacer **124** is engaged. The removable spacer **124** may be further fixed in place magnetically (not shown).

Alternatively, in FIG. 12, a sensor **10M** is illustrated in which the distance between a first portion **132** and a second portion **134** of the clip-style sensor **10M** is controlled by a sliding pin **136**. The sliding pin **136** and the first portion **132** and the second portion **134** are partially enclosed within a housing **137**. The first portion **132** and the second portion **134** have attachment slots **138** that are able to engage the sliding pin **136**. Thus, when the sliding pin **136** is pulled, the first portion **132** and the second portion **134** move towards one another. When the sliding pin **136** is pushed, the first portion **132** and the second portion **134** move away from one another. The first portion **132** and the second portion **134** may be adapted to house an emitter and a detector (not shown). To apply the sensor **10M** to the patient, the sliding pin **136** is pushed into the housing **137** to increase the distance between the first portion **132** and the second portion **134** in order to accommodate the patient's tissue. The sliding pin **136** may then be pushed into the housing **137** until the desired pressure from the sensor **10M** on the patient's tissue is reached.

A sensor, illustrated generically as a sensor **10**, may be used in conjunction with a pulse oximetry monitor **140**, as illustrated in FIG. 13. It should be appreciated that the cable **142** of the sensor **10** may be coupled to the monitor **140** or it may be coupled to a transmission device (not shown) to facilitate wireless transmission between the sensor **10** and the monitor **140**. The monitor **140** may be any suitable pulse oximeter, such as those available from Nellcor Puritan Bennett Inc. Furthermore, to upgrade conventional pulse oximetry provided by the monitor **140** to provide additional functions, the monitor **140** may be coupled to a multi-parameter patient monitor **144** via a cable **146** connected to a sensor input port or via a cable **148** connected to a digital communication port.

The sensor **10** includes an emitter **150** and a detector **152** that may be of any suitable type. For example, the emitter **150** may be one or more light emitting diodes adapted to transmit one or more wavelengths of light in the red to infrared range, and the detector **152** may be one or more photodetectors selected to receive light in the range or ranges emitted from the emitter

150. Alternatively, an emitter **150** may also be a laser diode or a vertical cavity surface emitting laser (VCSEL). An emitter **150** and detector **152** may also include optical fiber sensing elements. An emitter **150** may include a broadband or "white light" source, in which case the detector could include any of a variety of elements for selecting specific wavelengths, such as reflective or refractive elements or interferometers. These kinds of emitters and/or detectors would typically be coupled to the rigid or rigidified sensor via fiber optics. Alternatively, a sensor **10** may sense light detected from the tissue is at a different wavelength from the light emitted into the tissue. Such sensors may be adapted to sense fluorescence, phosphorescence, Raman scattering, Rayleigh scattering and multiphoton events or photoacoustic effects. For pulse oximetry applications using either transmission or reflectance type sensors the oxygen saturation of the patient's arterial blood may be determined using two or more wavelengths of light, most commonly red and near infrared wavelengths. Similarly, in other applications, a tissue water fraction (or other body fluid related metric) or a concentration of one or more biochemical components in an aqueous environment may be measured using two or more wavelengths of light, most commonly near infrared wavelengths between about 1,000 nm to about 2,500 nm. It should be understood that, as used herein, the term "light" may refer to one or more of ultrasound, radio, microwave, millimeter wave, infrared, visible, ultraviolet, gamma ray or X-ray electromagnetic radiation, and may also include any wavelength within the radio, microwave, infrared, visible, ultraviolet, or X-ray spectra.

The emitter **150** and the detector **152** may be disposed on a sensor body **154**, which may be made of any suitable material, such as plastic, foam, woven material, or paper. Alternatively, the emitter **150** and the detector **152** may be remotely located and optically coupled to the sensor **10** using optical fibers. In the depicted embodiments, the sensor **10** is coupled to a cable **142** that is responsible for transmitting electrical and/or optical signals to and from the emitter **150** and detector **152** of the sensor **10**. The cable **142** may be permanently coupled to the sensor **10**, or it may be removably coupled to the sensor **10**—the latter alternative being more useful and cost efficient in situations where the sensor **10** is disposable.

The sensor **10** may be a "transmission type" sensor. Transmission type sensors include an emitter **150** and detector **152** that are typically placed on opposing sides of the sensor site. If the sensor site is a fingertip, for example, the sensor **10** is positioned over the patient's fingertip such that the emitter **150** and detector **152** lie on either side of the patient's nail bed. In other words, the sensor **10** is positioned so that the emitter **150** is located on the patient's fingernail and the detector **152** is located 180° opposite the emitter **150** on the patient's finger pad. During operation, the emitter **150** shines one or more wavelengths of light through the patient's fingertip and the light received by the detector **152** is processed to determine various physiological characteristics of the patient. In each of the embodiments discussed herein, it should be understood that the locations of the emitter **150** and the detector **152** may be exchanged. For example, the detector **152** may be located at the top of the finger and the emitter **150** may be located underneath the finger. In either arrangement, the sensor **10** will perform in substantially the same manner.

Reflectance type sensors also operate by emitting light into the tissue and detecting the light that is transmitted and scattered by the tissue. However, reflectance type sensors include an emitter **150** and detector **152** that are typically placed on the same side of the sensor site. For example, a reflectance type sensor may be placed on a patient's fingertip or forehead such that the emitter **150** and detector **152** lay side-by-side.

Reflectance type sensors detect light photons that are scattered back to the detector **152**. A sensor **10** may also be a “transflectance” sensor, such as a sensor that may subtend a portion of a baby’s heel.

While the invention may be susceptible to various modifications and alternative forms, specific embodiments have been shown by way of example in the drawings and have been described in detail herein. However, it should be understood that the invention is not intended to be limited to the particular forms disclosed. Indeed, the present techniques may not only be applied to measurements of blood oxygen saturation, but these techniques may also be utilized for the measurement and/or analysis of other blood and/or tissue constituents using principles of pulse oximetry. For example, using the same, different, or additional wavelengths, the present techniques may be utilized for the measurement and/or analysis of carboxyhemoglobin, methemoglobin, total hemoglobin, fractional hemoglobin, intravascular dyes, and/or water content. Rather, the invention is to cover all modifications, equivalents, and alternatives falling within the spirit and scope of the invention as defined by the following appended claims.

What is claimed is:

1. A sensor comprising:
 - a conformable sensor body comprising an adhesive layer disposed on a tissue-contacting surface, wherein the sensor body is configured to wrap around an end of a patient’s digit;
 - a rigid housing disposed on the conformable sensor body on the tissue-contacting surface and configured to directly contact a patient’s tissue when in use; and
 - an emitter and a detector embedded in the rigid housing in a reflectance configuration, wherein the rigid housing is adapted to hold the emitter and the detector at a fixed optical distance relative to one another and relative to the patient’s digit when the sensor is attached to a patient and when the sensor experiences an external tapping force or when the digit applies a flexing force to the sensor.
2. The sensor, as set forth in claim 1, wherein the sensor comprises at least one of a blood constituent sensor or a tissue constituent sensor.
3. The sensor, as set forth in claim 1, wherein the sensor comprises at least one of a pulse oximetry sensor or a sensor for measuring a water fraction.
4. The sensor, as set forth in claim 1, wherein the rigid housing is disposed on the sensor body proximate to a midpoint of a longest dimension of the sensor body.
5. The sensor, as set forth in claim 4, wherein the emitter and the detector are disposed along an axis along the longest dimension of the sensor body.
6. The sensor, as set forth in claim 1, wherein the rigid housing is sized and shaped to allow bending of a first joint of the patient’s digit when the sensor is applied to the patient.
7. The sensor, as set forth in claim 1, wherein the rigid housing comprises a metal or a rigid polymeric material.
8. The sensor, as set forth in claim 1, comprising an adhesive disposed on a tissue-contacting surface of the rigid housing.
9. The sensor, as set forth in claim 1, wherein both the emitter and the detector are disposed on a same half of the sensor body with respect to an axis approximately orthogonal to a longest dimension of the sensor body.
10. The sensor, as set forth in claim 9, comprising a cable disposed on the same half of the sensor body, coupled to the

emitter and the detector, and configured to transmit signals to and from the emitter and the detector.

11. The sensor, as set forth in claim 1, comprising a removable rigid member separate from the rigid housing and disposed within an open cavity in the sensor body.

12. A pulse oximetry system comprising:
 - a pulse oximetry monitor; and
 - a pulse oximetry sensor adapted to be operatively coupled to the monitor, the sensor comprising:
 - a conformable sensor body comprising an adhesive layer disposed on a tissue-contacting surface, wherein the sensor body is configured to wrap around an end of a patient’s digit;
 - a rigid housing disposed on the conformable sensor body on the tissue-contacting surface and configured to directly contact a patient’s tissue when in use; and
 - an emitter and a detector embedded in the rigid housing in a reflectance configuration, wherein the rigid housing is adapted to hold the emitter and the detector at a fixed optical distance relative to one another and relative to the patient’s digit when the sensor is attached to a patient and when the sensor experiences an external tapping force or when the digit applies a flexing force to the sensor.

13. The system, as set forth in claim 12, wherein the sensor comprises a tissue constituent sensor.

14. The system, as set forth in claim 12, wherein the sensor comprises a sensor for measuring a water fraction.

15. The system, as set forth in claim 12, wherein the rigid housing is disposed on the sensor body proximate to a midpoint of a longest dimension of the sensor body.

16. The system, as set forth in claim 15, wherein the emitter and the detector are disposed along an axis along the longest dimension of the sensor body.

17. The system, as set forth in claim 12, wherein the rigid housing comprises a metal or a rigid polymeric material.

18. A method of manufacturing a pulse oximetry sensor, comprising:

- providing a conformable sensor body comprising an adhesive layer disposed on a tissue-contacting surface adapted to wrap around an end of a patient’s digit;
- providing a rigid housing, wherein the rigid housing comprises an emitter and detector disposed on or in the rigid housing in a reflectance configuration; and
- disposing the rigid housing on the tissue-contacting surface of the conformable sensor body, wherein the rigid housing is adapted to hold the emitter and the detector at a fixed optical distance relative to one another and relative to the patient’s digit and to directly contact a patient’s tissue when the sensor is attached to a patient and when the sensor experiences an external tapping force or when the digit applies a flexing force to the sensor.

19. The method, as set forth in claim 18, wherein the sensor comprises at least one of a blood constituent sensor or a tissue constituent sensor.

20. The method, as set forth in claim 18, wherein disposing the rigid housing on the conformable sensor body comprises disposing the rigid housing such that the emitter and the detector are positioned along an axis along the longest dimension of the sensor body.

专利名称(译)	用于减少运动伪影的医疗传感器及其使用技术		
公开(公告)号	US8965473	公开(公告)日	2015-02-24
申请号	US13/267681	申请日	2011-10-06
[标]申请(专利权)人(译)	内尔科尔普里坦贝内特公司		
申请(专利权)人(译)	NELLCOR PURITAN BENNETT LLC		
当前申请(专利权)人(译)	COVIDIEN LP		
[标]发明人	HOARAU CARINE BAKER JR CLARK R KARST EDWARD		
发明人	HOARAU, CARINE BAKER, JR., CLARK R. KARST, EDWARD		
IPC分类号	A61B5/1455 A61B5/00		
CPC分类号	A61B5/6886 A61B5/14552 A61B5/6826 A61B5/6838 A61B5/6844 Y10T29/49826		
其他公开文献	US20120035443A1		
外部链接	Espacenet USPTO		

摘要(译)

用于脉搏血氧测定法或利用分光光度法的其他应用的传感器可以适于通过固定发射器和检测器之间的光学距离来减少运动伪影。柔性传感器设置有加强构件，以在应用于患者时将传感器的发射器和检测器保持在相对固定的位置。此外，环形或部分环形传感器适于在应用于患者时将传感器的发射器和检测器保持在相对固定的位置。夹式传感器设有间隔器，用于控制发射器和检测器之间的距离。

