



(19) **United States**

(12) **Patent Application Publication**  
**Smith et al.**

(10) **Pub. No.: US 2011/0118562 A1**

(43) **Pub. Date: May 19, 2011**

(54) **PORTABLE ULTRASOUND SCANNER**

**Publication Classification**

(75) Inventors: **Johannes Anders Smith**, Hellerup (DK); **Ole Christian Jensen**, Vaerlose (DK)

(51) **Int. Cl.**  
**A61B 5/00** (2006.01)  
**A61B 8/00** (2006.01)

(52) **U.S. Cl.** ..... **600/301; 600/437**

(73) Assignee: **B-K MEDICAL APS**, Herlev (DK)

(57) **ABSTRACT**

(21) Appl. No.: **12/619,797**

An apparatus includes a plurality of portable scanners and docks. The scanners include first and second configurations to provide different functionality. The docks include at least one of floor, a wall, and a table dock. The scanners are selectively mateable to the various docks.

(22) Filed: **Nov. 17, 2009**

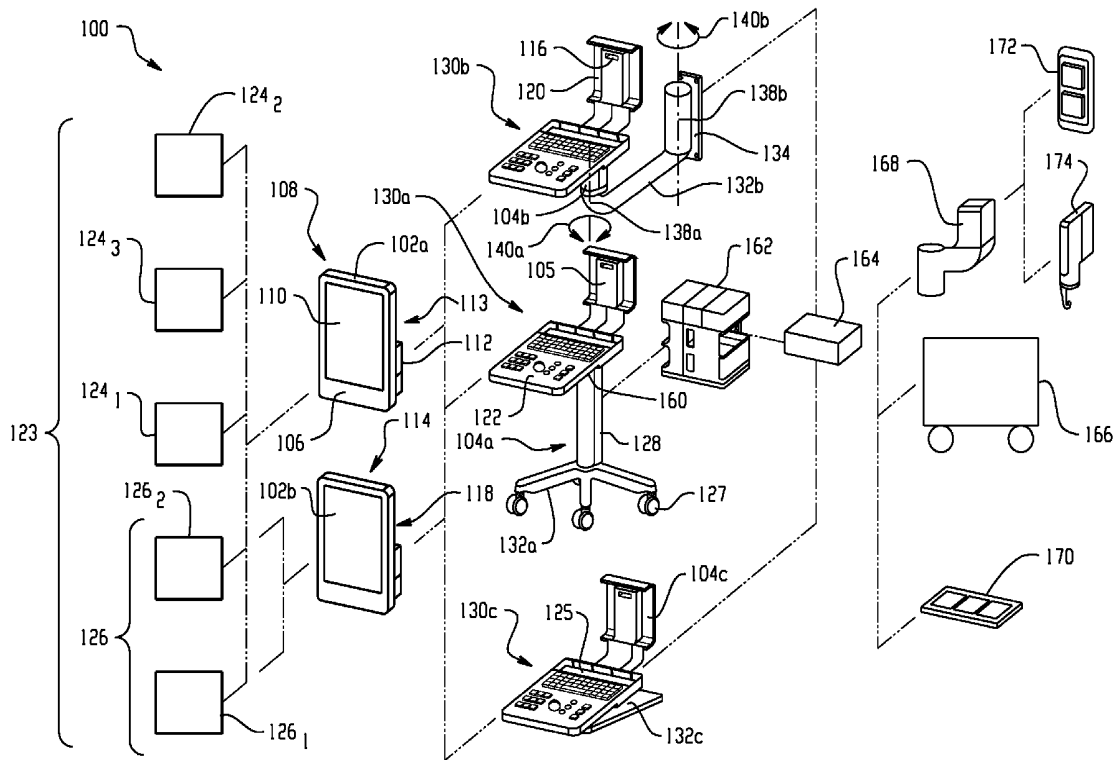

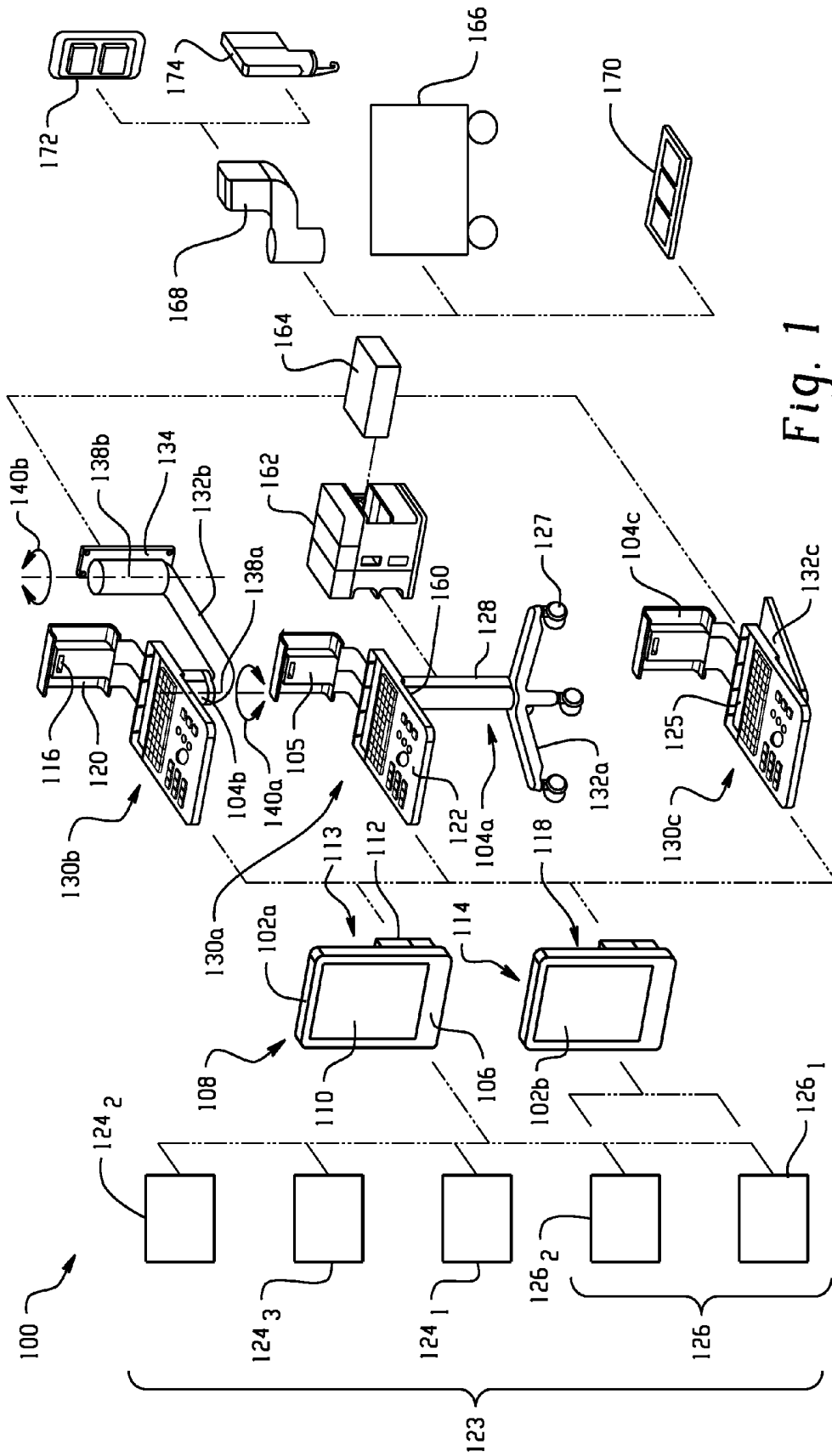

Fig. 1

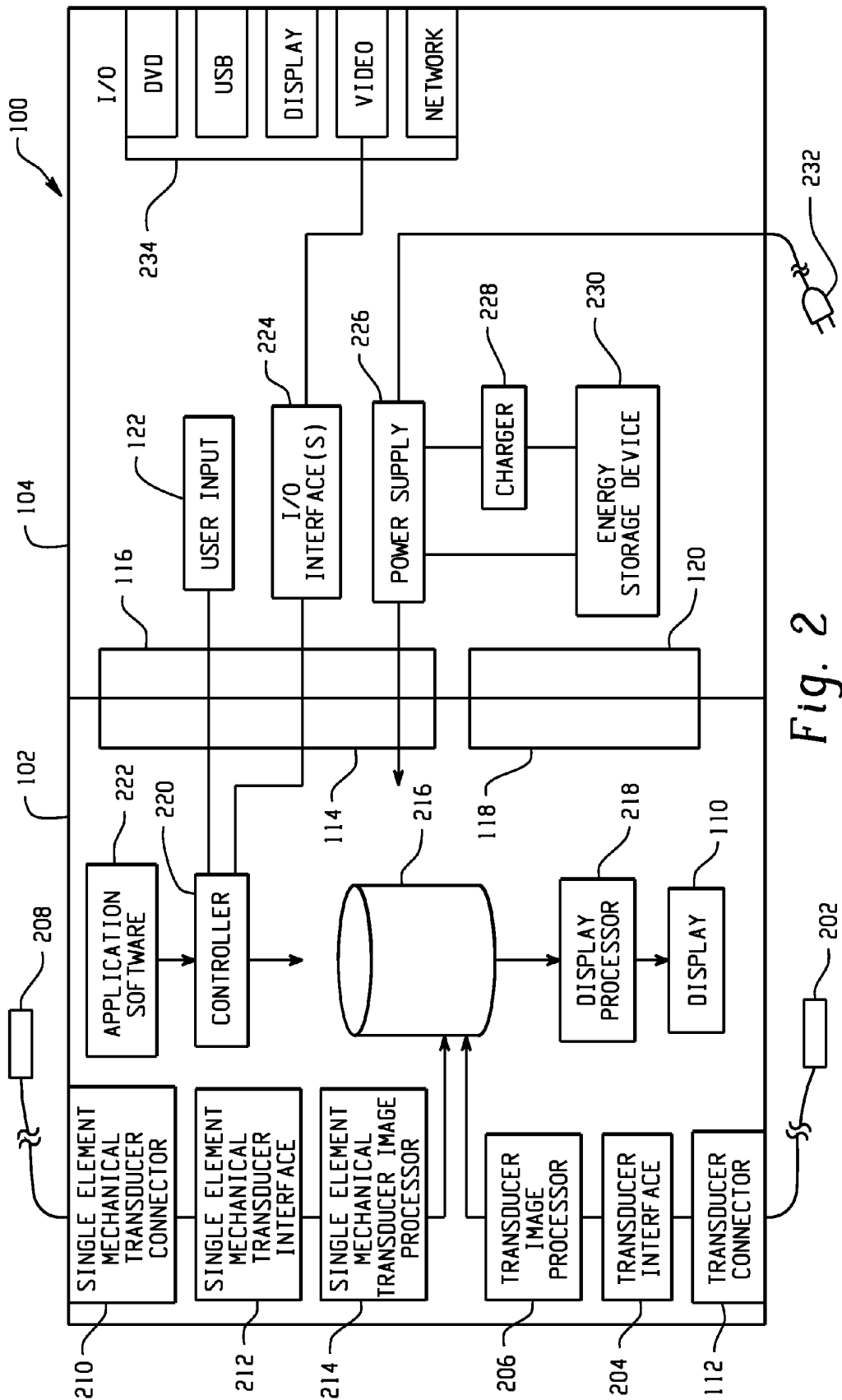

Fig. 2

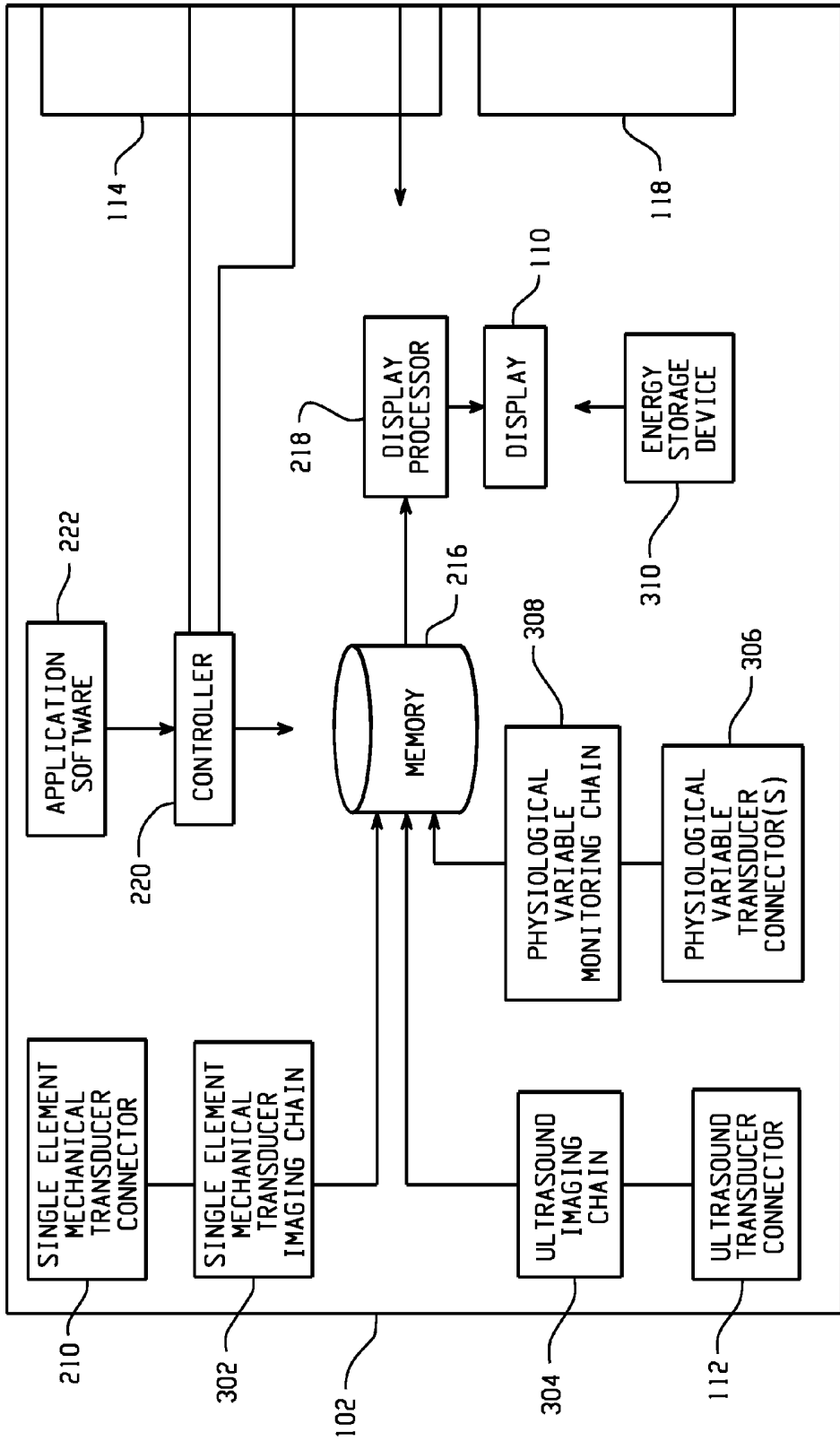

Fig. 3

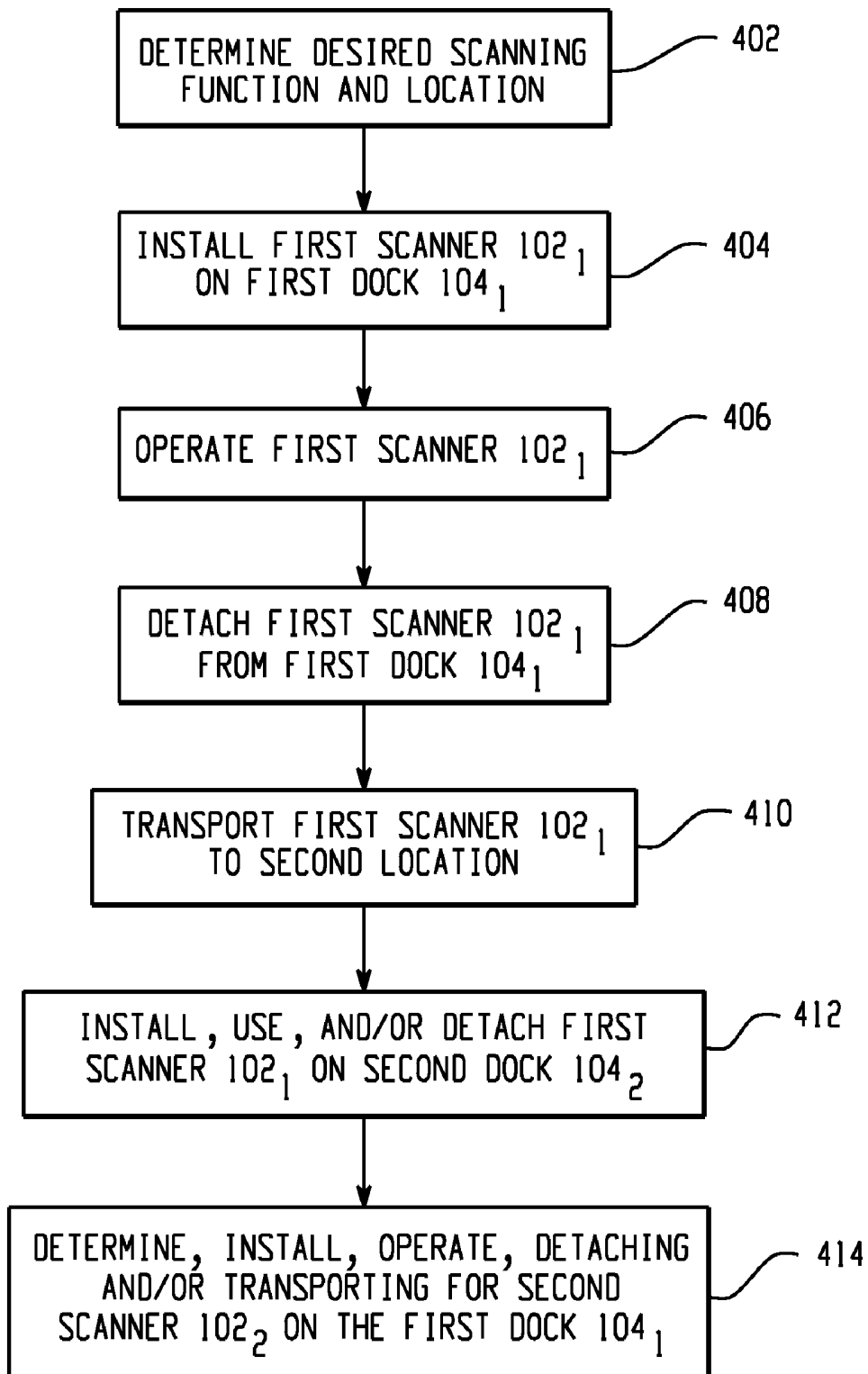

Fig. 4

## PORTABLE ULTRASOUND SCANNER

### BACKGROUND

[0001] The present application relates to physiological monitoring devices. While it finds particular application to ultrasound scanners in medical and veterinary applications, it also applies to the monitoring of other physiological variables.

[0002] Ultrasound scanners provide useful information about the interior characteristics of an object under examination. In medical applications, clinicians have used ultrasound scanners to examine human subjects in settings such as hospitals, physician's offices, and other locations. Ultrasound scanners have been used in the emergency room, operating room, and similar environments.

[0003] Other types of physiological variable scanners are also known. Examples include blood pressure, respiration, cardiac, glucose, and oxygen saturation monitors.

[0004] Applications for these scanners often place a premium on size and convenience. In an operating room, for example, space is often at a premium, and the scanner may come into contact with bodily fluids. Moreover, it is sometimes desirable to transport the scanner from room-to-room. To this end, portable scanners have been equipped with wheeled carts that allow the scanner to be rolled along the floor.

[0005] Other scanners have taken the generally clam-shell form factor of a laptop computer, with a display hingedly attached to a keyboard. The necessary interfaces have been included in the laptop-like unit so that the transducers, input output devices, and other peripherals can be connected to the laptop like unit as needed. These scanners are configured to be placed on a relatively flat surface such as a tabletop, the surface of a wheeled utility cart, or the like. Unfortunately, such a surface is not always readily available or may be inconvenient. The external interface connections also tend to be relatively inconvenient.

### SUMMARY

[0006] Aspects of the present application address the above matters, and others.

[0007] According a first aspect of the present application, a system includes a first dock including a first portion and a base portion. The first portion of the first dock includes a user interface and a power supply. The base portion of the first dock is configured to support the first portion of the first dock relative to a first surface. The system also includes a second dock including a first portion and a base portion. The first portion of the second dock includes a user interface and a power supply. The base portion of the second dock is configured to support the second portion of the second dock relative to a second surface. The systems also includes first portable ultrasound scanner including an ultrasound transducer interface, a display, and a dock interface that selectively connects the first scanner to the first and second docks for operation in conjunction therewith.

[0008] According to another aspect of the present application, an apparatus includes a first portable scanner including an ultrasound transducer interface, a display, and a dock interface that selectively connects the first scanner to a dock for operation in conjunction therewith. The apparatus also includes a second portable scanner including a transducer interface, a display, and a dock interface that selectively con-

nects the first scanner to the first and second docks for operation in conjunction therewith. The apparatus also includes a first dock including a scanner interface that selectively receives the first and second scanners. The first dock includes a user interface that varies an operation of a scanner received by the first dock. The second portable scanner is configured to provide functionality different from the functionality of the first portable scanner.

[0009] According to another aspect of the present invention, a method includes installing a first portable scanner on a first scanner dock, using the first scanner to perform a first desired function, detaching the first portable scanner from the first dock, installing the first portable scanner on a second dock, and using the first scanner to perform a second different desired function.

[0010] Those of ordinary skill in the art will appreciate still other aspects of the present invention upon reading and understanding the appended description.

### FIGURES

[0011] The application is illustrated by way of example and not limitation in the figures of the accompanying drawings, in which like references indicate similar elements and in which:

[0012] FIG. 1 depicts an ultrasound scanner.

[0013] FIG. 2 is a functional block diagram of an ultrasound scanner.

[0014] FIG. 3 is a functional block diagram of a scanner.

[0015] FIG. 4 depicts a scanning method.

### DESCRIPTION

[0016] With reference to FIG. 1, an ultrasound imaging apparatus 100 includes one or more portable ultrasound scanners 102a, 102b that selectively mate with one or more docks such as a floor dock 104a, a wall dock 104b, and a table dock 104c.

[0017] In the illustrated implementation, the form factors of the scanners 102a, 102b are substantially identical. Each scanner 102 includes front 106 and rear 108 major surfaces. A human readable display 110 such as a flat panel LCD display is visible from the front surface 106. Also as illustrated, the displays 110 and scanners 102 are oriented in the portrait mode, with each having a vertical dimension greater than its respective horizontal dimension.

[0018] An ultrasound transducer connector 112 located at a side of each scanner 102 is configured to connect to the corresponding connector of an ultrasound transducer. The scanners 102 may also include a single element mechanical transducer connector for connecting to a single element mechanical transducer. In one implementation, the displays 110 have respective diagonal, vertical and horizontal dimension of about 19 inches (48.3 cm).

[0019] The scanners 102 include a dock interface 113 for connecting the scanners 102 to the various docks 104. One or more electrical connectors 114 located at the rear 108 of the scanners 102 are configured to connect to corresponding connector(s) 116 of the docks 104. One or more mechanical connectors 118 also located to the rear 108 of the scanners 102 allow the user to selectively attach the scanners 102 to a connector 120 of a desired dock 104. The mechanical connectors 118 may take the form of a user operable latch, a dock 104 mounted sleeve that accepts the scanners 102, or the like. It will be appreciated that the electrical 114 and mechanical 118 connectors may be configured in a single connector. In

the illustrated implementation, the scanners **102** are functional only when mated to a dock **104**.

[0020] As illustrated in FIG. 1, the scanners **102** are configured to provide different functionality **123**. For examples, in one embodiment one of the scanners **102** is a full-featured scanner supporting a set of applications including single element mechanical transducer functionality, another of the scanners **102** is a lower functionality scanner supporting a subset of the set of applications (e.g., without single element mechanical transducer functionality), another of the scanners **102** is a dedicated scanner such as a scanner that supports surgical transducers for surgical applications, and another of the scanners **102** is a lower functionality dedicated scanner supporting a subset of the surgical applications. Other scanners with other functionality are also contemplated herein. The particular applications supported by a scanner **102** may be predetermined and/or purchasable software applications and/or hardware.

[0021] By way of another example, the first scanner **102a** may perform a first set **124** of functions, and the second scanner **102b** may perform a second set **126** of functions, where the second set **126** is a subset of the first set **124**. The second set **126** may include a relatively basic set of functions such as digital information and communication in medicine (DICOM) **126<sub>1</sub>**, communication and color flow mode (CFM) **126<sub>2</sub>**, imaging capabilities. The first set **124** may include the functions of the second set **126**, as well as other desired functions such as three dimensional image rendering and/or manipulation **124<sub>1</sub>**, a brachytherapy interface **124<sub>2</sub>**, an endoscopy interface **124<sub>3</sub>**, or similar capabilities. In another instance, the second set of functions **126** is different from the first set of functions **124**.

[0022] Different versions of the scanners **102** may each be configured to perform ultrasound imaging functions used in one or more different medical specialties such as urology, anesthesiology, general radiology, or the like. Thus, for example, different scanners **102** may be configured to include functionality typically required in one or more of urological ultrasound, anesthesiology, gastroenterology, surgery, general radiology, and so on. For example, a urological scanner may be configured to interface with a transrectal or transvaginal probe and/or provide user interface functionality typically required in urological applications; a gastroenterological scanner may be configured to interface with a transesophageal probe and provide user interface functionality typically required in gastroenterological applications, an anesthesiology scanner may be configured to guide the application of an epidural or nerve block under substantially real time ultrasound image guidance, and so on.

[0023] With continuing reference to FIG. 1, the docks **104** include a common portion **130** and a base portion **132**. As illustrated, the common portions **130a**, **130b**, **130c** of the respective docks **104a**, **104b**, **104c** have the same form factor and are substantially mechanically and electrically identical. The base portions **132a**, **132b**, **132c** are configured to support the common portions **130a**, **130b**, **130c** relative to a desired surface.

[0024] The common portions **130** include a user input device or interface **122**, a scanner interface **105** and one or more transducer holders **125** that are configured to hold ultrasound transducers that are not in use. In one embodiment, the one or more transducer holders **125** are omitted from at least one of the common portions **130**. The user interface **122** includes an input device such as a keyboard, a trackball, a

trackpad, a touch-based interface, and/or other input device. The docks **104** receive the scanners **102** generally in the region of the scanner interface **105**, which includes mechanical and/or electrical interfaces corresponding to those on the scanners **102**. The common portions **130** also include various input/output (I/O) devices such as a DVD drive or slot, universal serial bus (USB) port, wired or wireless network interfaces for communicating with a picture archiving and communications system (PACS), hospital information system/radiology information system (HIS/RIS), auxiliary display or video interfaces, or the like.

[0025] The common portions **130** also include a power supply that provides power to a scanner **102**. The power supply may be located in the region of the scanner interface **105** (e.g., generally behind the scanner **102**), in the arm that supports the scanner **102**, or in the region of the user interface **122**.

[0026] The base portion **132a** of floor dock **104a** supports the common portion **130a** of the dock **104a** relative to a floor or other similar surface. As illustrated, the floor dock **104a** includes four (4) or another desired number of wheels **127** located on supports extending radially from a vertical post **128** that supports the common portion **130a** relative to the floor. In one implementation, the post **128** is telescoping or otherwise adjustable to at least a high and a low position. At the low position, the top of a scanner **102** mated to the floor dock **104a** is at a height that allows an average user to see over the top of the scanner **102** when rolling the unit across the floor.

[0027] In one implementation, the low position is selected so that the top of the scanner **102** is about 53 inches (135.0 cm) from the floor. At the high position, the display **110** of a scanner **102** mated to the floor dock **104a** is located at approximately eye level of a standing human user. In one implementation, the high position is selected so that the mid-point of the display **110** is about 63 inches (160.2 cm) from the floor. Still other relatively higher, lower, and intermediate positions are contemplated. As one example, the height may be adjustable so that the keyboard **122** and display **110** are convenient for a user seated in a typical chair.

[0028] An accessory mount **160** is located generally to the rear of the post **128**, for example by way of a flat surface. An accessory holder **162** removably attaches to the accessory mount **160**. The accessory holder **162** likewise removably carries one more accessory devices such as a printer **164**. Suitable electrical connections provide power and signal connections so that the accessory devices operate in conjunction with a scanner attached to the dock **104a**. Preferably, at least one of the accessory holders **162** and the printer **164** are readily attachable and detachable from the dock **104a** without tools.

[0029] The base **132c** of the table dock **104c** supports the common portion **130c** relative to a table, desktop, or other similar surface. As illustrated, the base **132c** rests on or otherwise supports the dock **104c** on the surface.

[0030] The base **132b** of the wall dock **104b** supports the scanner **102** relative to a vertical surface such as a wall. A wall mount **134** located at the distal end of the wall base **132b** is used to fasten the wall dock **104b** to the wall. The common portion **130b** is located at the proximal end of the wall dock **104b**. As illustrated, the wall dock **104b** includes first **138a** and second **138b** pivots located near the proximal and distal ends, respectively. The pivots **138** are configured to pivot about substantially vertical axes of rotation **140a**, **140b**,

thereby allowing the proximal end of the dock **104b** to be located relatively nearer to or farther from the wall, while allowing the common portion **130b** to face in a desired direction relative to the wall. Vertical or other adjustments are also contemplated.

[0031] Ceiling, vehicular, or other docks **104** are also contemplated.

[0032] A wheeled transport case **166** receives the accessory holder **162** and/or the accessories **164** and facilitates transport of the accessories. Where used with a wall **104b**, table **104c**, or other dock, electrical connections may be provided as desired, for example through suitable cabling. Other accessories such as an endoscopic transducer holder **168** or a foot switch **170** may also be included in the system **100** and likewise be transported. Other accessories such as a transducer wall mount **172** and a transducer holder wall mount **174** may also be provided to facilitate transducer handling and cable management, particularly for transducers not in use.

[0033] FIG. 2 is a functional block diagram of an ultrasound imaging apparatus **100** including a scanner **102** and a dock **104**. The scanner **102** includes ultrasound imaging functionality and single element mechanical transducer support.

[0034] Turning first to the ultrasound imaging chain, a transducer interface **204** interfaces with an ultrasound transducer **202** connected to the connector **112**. The configuration and functionality of the transducer **202** and transducer interface **204** are typically application dependent.

[0035] A transducer image processor **206** in operative communication with the transducer interface **204** generates three-dimensional (3D) or other ultrasound image data indicative of an object under examination for storage in a suitable computer readable memory **216**.

[0036] Turning to the single element mechanical transducer imaging chain, a single element mechanical transducer interface **212** interfaces to an single element mechanical transducer **208** connected to single element mechanical transducer connector **210**. An ultrasound image processor **214** in operative communication with the single element mechanical interface **212** generates image data indicative of an object under examination for storage in the memory **216**.

[0037] A display processor **218** processes the ultrasound image data for display on the display **110**. Processing and display of the ultrasound typically occur in substantially real time during the course of an examination of an object.

[0038] A controller **220** such as a microprocessor or microcontroller controls the operation of the scanner **102**. Application software **222** is configured to provide the functions **124**, **126** or other desired application functionality.

[0039] The electrical connector **116** provides electrical connections between the scanner **102** the dock-mounted devices such as the user input **122**, the I/O interface(s) **224** and the power supply **226**.

[0040] The power supply **226** receives power from an external power source such as 120/240 Vac power mains, vehicular power source, or the like through a line cord or other electrical connection **232** and provides electrical power at the voltage and current levels required by the apparatus **100**. The dock **104** may also include a rechargeable energy storage device **230** such as a rechargeable battery to provide operating power while the dock **104** is not connected to an external power source. A charger **228** charges the energy storage device **230**.

[0041] In one implementation, the energy storage device **230** provides sufficient energy to power the scanner for only a relatively short period of time, for example on the order of

less than about sixty (60) minutes. In the case of the floor dock **104a**, such an implementation allows the unit to be moved from room to room without completely de-powering the scanner **102**. The scanner **102** may also enter a reduced power or sleep mode when external power is not available or the dock **104** is otherwise not connected to the external power source. The dock **104** also includes desired I/O interface(s) **224** and connection(s) **234** such as those for one or more of a DVD, USB, display, video, digital communication network, or the like.

[0042] FIG. 3 depicts a second implementation of a portable scanner **102**. The scanner **102** includes single element mechanical transducer **302** and ultrasound **304** imaging chains generally as described above in connection with FIG. 2. The scanner **102** also includes one or more physiological variable transducer connectors **306** and physiological variable monitoring chains **308**. The physiological variable(s), which are typically presented on the display **110** in substantially real time, may include variables such as pulse rate, blood pressure, oxygen saturation, glucose, cardiac characteristics such as cardiac function or output, or electrocardiogram (EKG) signals, respiration or the like. The scanner **102** also includes an energy storage device **310** so that the scanner may be operated independently of a dock **104**. The device may be also configured so that the scanner **102** is substantially non-operational but remains in a suspend mode when not so connected.

[0043] Variations are contemplated. The various signal chains may be implemented in any combination. For example, versions of the scanner **102** may include both ultrasound imaging and single element mechanical transducer support, single element mechanical transducer support standing alone, ultrasound capability standing alone, or the like. Different versions of the scanner **102** may be configured to measure physiological variable(s) in differing combinations. In another variation, the scanner **102** may include user-replaceable modules such as cards or pods that allow the user to configure the scanner **102** to provide desired functionality (e.g., modules specific to a particular variable or transducer type

[0044] Versions of the scanner **102** may also have differing exterior form factors. Preferably, however, the various scanners **102** are configured to be electrically and mechanically interchangeable among the various docks **104**. Versions of the scanner **102** may also include user input functionality similar to user input **122**, implemented for example by way of a touch screen implemented on the display **110**. In a related variation, the user input **122** may be omitted from one or more versions of the dock **104**. The controller **220** senses or otherwise determines if the scanner **102** is connected to a dock **104** that does not include a user input **122**, in which case the scanner **102** operates via its internal user input.

[0045] In another implementation, the ultrasound transducer **202** includes a bi-plane or tri-plane transducer. A bi-plane transducer acquires image information in two planes or directions; a tri-plane transducer acquires imaging information in three planes or directions. In the case of a bi-plane transducer, the two images can be presented simultaneously on the display **110**. Where the display **110** is configured in the portrait mode, the two images can be displayed in a vertically stacked arrangement, with one of the images being located physically above the other. Where the display **100** is sized substantially as described above, the size of the presented images can be relatively large.

[0046] Similar results can be achieved with a tri-plane transducer, although the simultaneous presentation of three images may require that the images be somewhat smaller or the display 110 relatively larger. Similar results may also be achieved in the case of single plane transducers. It will also be appreciated that similar displays may be implemented where the scanner 102 is configured to simultaneously present a combination of two or more of ultrasound, physiological, or endoscopic data. It will also be appreciated that, for a given display 110 size, the portrait arrangement tends to reduce the footprint of the scanner 102.

[0047] The scanner 102 and dock 104 configuration may be exploited in various ways. For example, depending on factors such as the time of day, the patient(s) being seen, or the type of scan to be performed at a given location, the physician or other user may select a scanner 102 having the desired functionality and install it on the available dock 104. Similarly, the user may employ a particular scanner 102 at each of a number of locations. As another example, the user may readily transport a single scanner 102 for use in a plurality of locations or readily upgrade the scanner 102 as his or her needs change. In locations where space is particularly valuable, the user may install a dock 104 that does not include a user input.

[0048] An operation of the apparatus 100 will now be described in relation to FIG. 4. At 402, the user determines a desired scanning function to be conducted at a first location. For the purposes of the present example, it will be assumed that the user desires to conduct an ultrasound imaging scan. It will also be assumed that the first location is an examination room that contains a first wall dock 104<sub>1</sub>.

[0049] At 404, the user installs a first scanner 102<sub>1</sub> that performs the desired scanning functions on the first dock 104<sub>1</sub>. If not already connected, the user connects the requisite transducers to the first scanner 102<sub>1</sub>.

[0050] At 406, the user operates the first scanner 102<sub>1</sub> as desired. For example, the user may conduct transrectal ultrasound examination of one or more human patient(s).

[0051] At 408, the user detaches the first scanner 102<sub>1</sub> from the first dock 104<sub>1</sub>. If not already detached, the user may elect to detach the requisite transducers from the first scanner 102<sub>1</sub>.

[0052] At 410, the user transports the first scanner 102<sub>1</sub> to a second location that includes a second dock 104<sub>2</sub>. For the purposes of the present example, it will be assumed that the second dock 104<sub>2</sub> includes a floor dock 104c.

[0053] At 412, the user performs the steps of installing, using, and/or detaching the first scanner 102<sub>1</sub> from the second dock 104<sub>2</sub> in a manner similar to steps 404, 406, 408 above. It will be appreciated that the particular examination and the object on which it is performed may be different.

[0054] At 414, the same or a different user may perform the steps of determining, installing, operating, detaching, and/or transporting for a second scanner 102<sub>2</sub> on the first dock 104<sub>1</sub>.

[0055] Those of ordinary skill in the art understand that numerous other permutations of the above are possible.

[0056] The application has been described with reference to various embodiments. Modifications and alterations will occur to others upon reading the application. It is intended that the invention be construed as including all such modifications and alterations, including insofar as they come within the scope of the appended claims and the equivalents thereof.

What is claimed is:

1. A system comprising:

a first dock including a first portion and a base portion, wherein the first portion of the first dock includes a user

interface and a power supply, and wherein the base portion of the first dock is configured to support the first portion of the first dock relative to a first surface;

a second dock including a first portion and a base portion, wherein the first portion of the second dock includes a user interface and a power supply, and wherein the base portion of the second dock is configured to support the second portion of the second dock relative to a second surface;

a first portable ultrasound scanner including an ultrasound transducer interface, a display, and a dock interface that selectively connects the first scanner to the first and second docks for operation in conjunction therewith.

2. The apparatus of claim 1 including a second portable ultrasound scanner including an ultrasound transducer interface, a display, and a dock interface that selectively connects the second scanner to the first and second docks for operation in conjunction therewith, wherein the first scanner performs a first set of ultrasound scanning functions and the second scanner performs a second set of ultrasound scanning functions, and the first set is a subset of the second.

3. The apparatus of claim 2 wherein the first set includes a DICOM function and a CFM function and the second set includes a three dimensional image display function and a brachytherapy function.

4. The apparatus of claim 1 wherein the first portable ultrasound scanner includes a single element mechanical transducer interface and the first scanner is configured to present information indicative of information received from the single element mechanical transducer on the display.

5. The apparatus of claim 4 wherein the first portion of the first dock includes an output that presents a video signal indicative of an image indicative of the received information from the first scanner.

6. The apparatus of claim 1 wherein the first portable ultrasound scanner includes a physiological variable transducer interface and the first scanner is configured to present information indicative of information received from the physiological variable transducer interface on the display.

7. The apparatus of claim 6 wherein the information includes information indicative of at least one of blood pressure, respiration, or a cardiac characteristic.

8. The apparatus of claim 1 wherein the user interfaces of the first and second docks are substantially identical.

9. The apparatus of claim 8 wherein the first portions of the first and second docks are substantially mechanically and electrically identical.

10. The apparatus of claim 1 wherein the first dock includes a wheeled floor dock and the second dock includes a wall dock or a ceiling dock.

11. The apparatus of claim 1 wherein the first dock is a floor dock including a vertical post that supports the common portion above the floor and the first dock includes a printer mounted behind the post.

12. An apparatus comprising:

a first portable scanner including an ultrasound transducer interface, a display, and a dock interface that selectively connects the first scanner to a dock for operation in conjunction therewith;

a second portable scanner including a transducer interface, a display, and a dock interface that selectively connects the first scanner to the first and second docks for operation in conjunction therewith;

a first dock including a scanner interface that selectively receives the first and second scanners, wherein the first dock includes a user interface that varies an operation of a scanner received by the first dock;

wherein the second portable scanner is configured to provide functionality different from the functionality of the first portable scanner.

**13.** The apparatus of claim **12** wherein the second portable scanner includes an ultrasound transducer interface.

**14.** The apparatus of claim **12** wherein the second portable scanner includes a physiological variable transducer interface.

**15.** The apparatus of claim **14** wherein the physiological variable includes a vital sign.

**16.** The apparatus of claim **12** wherein the functionality provided by the second scanner includes a subset of the functionality provided by the first scanner.

**17.** The apparatus of claim **12** including a second dock including a scanner interface that selectively receives the first and second scanners, wherein the second dock includes a user

interface that varies an operation of a scanner received by the second dock, the first dock includes a floor dock, and the second dock includes one of a ceiling and a wall dock.

**18.** The apparatus of claim **17** wherein the second transducer includes a single element mechanical transducer interface.

**19.** The apparatus of claim **12** wherein the display of the first portable scanner is oriented in the portrait mode, and the first scanner is configured to simultaneously present at least first and second ultrasound images on the display of the first portable scanner.

**20.** A method comprising:

installing a first portable scanner on a first scanner dock;  
using the first scanner to perform a first desired function;  
detaching the first portable scanner from the first dock;  
installing the first portable scanner on a second scanner dock; and  
using the first scanner to perform a second different desired function.

\* \* \* \* \*

专利名称(译)	便携超声扫描仪		
公开(公告)号	<a href="#">US20110118562A1</a>	公开(公告)日	2011-05-19
申请号	US12/619797	申请日	2009-11-17
[标]申请(专利权)人(译)	B-K医疗公司		
申请(专利权)人(译)	B-k医疗APS		
当前申请(专利权)人(译)	B-k医疗APS		
[标]发明人	SMITH JOHANNES ANDERS JENSEN OLE CHRISTIAN		
发明人	SMITH, JOHANNES ANDERS JENSEN, OLE CHRISTIAN		
IPC分类号	A61B5/00 A61B8/00		
CPC分类号	A61B8/00 A61B2560/0456 A61B8/4411 A61B8/5261 A61B8/4427 A61B8/4433 A61B8/4494		
其他公开文献	US9649089		
外部链接	<a href="#">Espacenet</a> <a href="#">USPTO</a>		

摘要(译)

一种装置包括多个便携式扫描仪和底座。扫描仪包括第一和第二配置以提供不同的功能。码头包括地板，墙壁和桌子平台中的至少一个。扫描仪可选择性地与各种码头配合。

