



(19) **United States**

(12) **Patent Application Publication**  
**Syroid et al.**

(10) **Pub. No.: US 2008/0033661 A1**  
(43) **Pub. Date: Feb. 7, 2008**

(54) **METHOD AND APPARATUS FOR MONITORING ANESTHESIA DRUG DOSAGES, CONCENTRATIONS, AND EFFECTS USING N-DIMENSIONAL REPRESENTATIONS OF CRITICAL FUNCTIONS**

**Related U.S. Application Data**

(63) Continuation of application No. 09/686,263, filed on Oct. 10, 2000, which is a continuation-in-part of application No. 09/457,068, filed on Dec. 7, 1999, now abandoned.

**Publication Classification**

(51) **Int. Cl.**  
**G06F 19/00** (2006.01)  
(52) **U.S. Cl.** ..... **702/22**

(76) Inventors: **Noah Syroid**, Salt Lake City, UT (US); **Dwayne R. Westenskow**, Salt Lake City, UT (US); **Julio C. Bermudez**, Salt Lake City (JP); **James Agutter**, Salt Lake City, UT (US); **David Lee Strayer**, Salt Lake City, UT (US); **Robert William Albert**, Salt Lake City, UT (US); **Michael E. Holmes**, Muncie, IN (US); **Frank Drews**, Salt Lake City, UT (US); **Hauanke Prenzel**, Luebeck (DE)

(57) **ABSTRACT**

A method, system and apparatus for the monitoring, diagnosis and evaluation of the state of a dynamic system is disclosed. This method and system provides the processing means for receiving sensed and/or simulated data, converting such data into a displayable object format and displaying such objects in a manner such that the interrelationships between the respective variables can be correlated and identified by a user. This invention provides for the rapid cognitive grasp of the overall state of a critical function with respect to a dynamic system. The system provides for displayed objects, which change in real-time to show the changes of the functions of the system. It is a highly flexible system which works with a wide variety of applications, including biological systems, environmental systems, engineering systems, economic systems, mechanical systems, chemical systems and the like. In particular, this invention is directed to the processing and display of drug data for the use of doctors in the process of monitoring or administering drugs to patients.

Correspondence Address:  
**BAKER & ASSOCIATES PLLC**  
**470 EAST NINTH AVENUE**  
**SALT LAKE CITY, UT 84103 (US)**

(21) Appl. No.: **11/843,524**

(22) Filed: **Aug. 22, 2007**

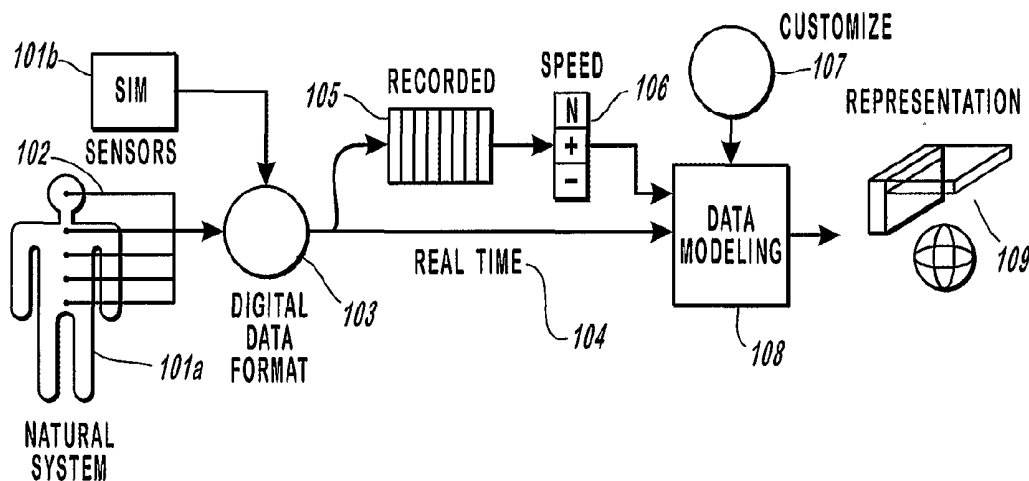

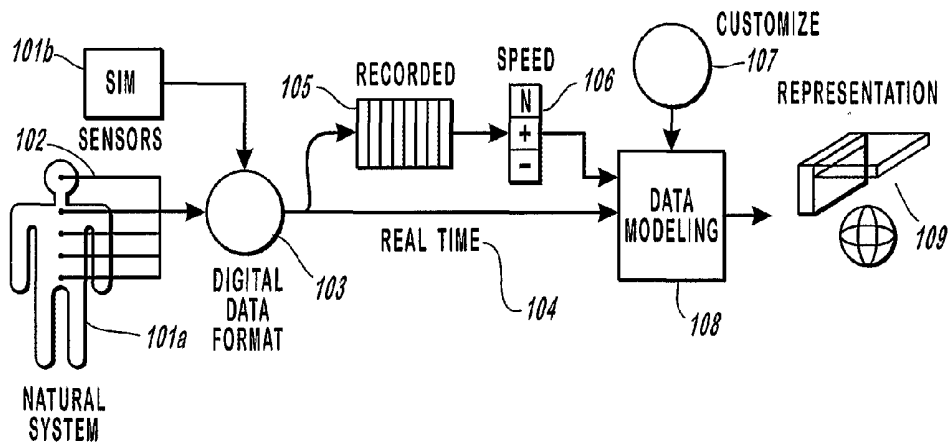

FIGURE 1a

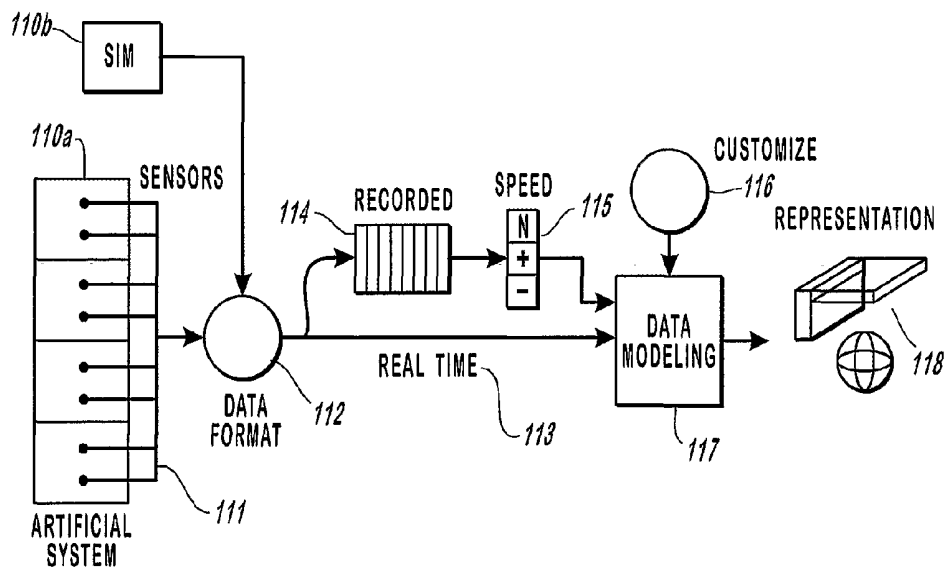

FIGURE 1b

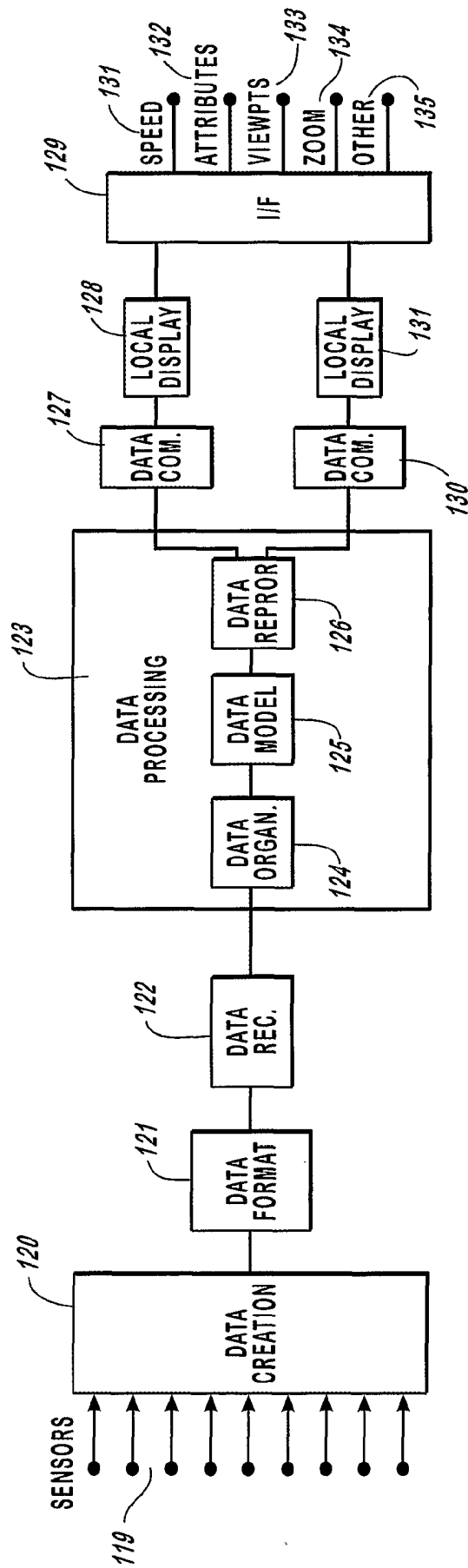

FIGURE 1c

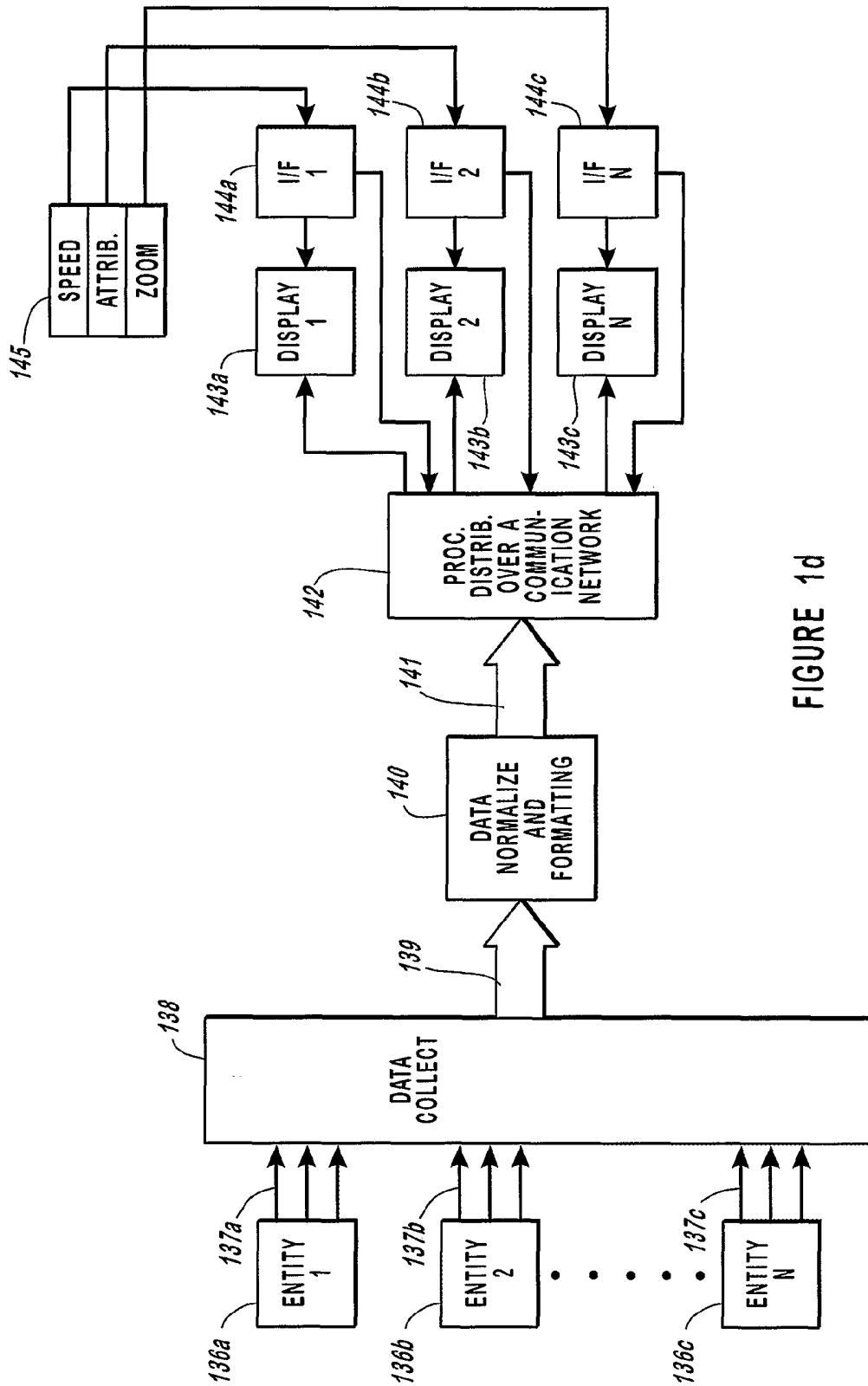

FIGURE 1d

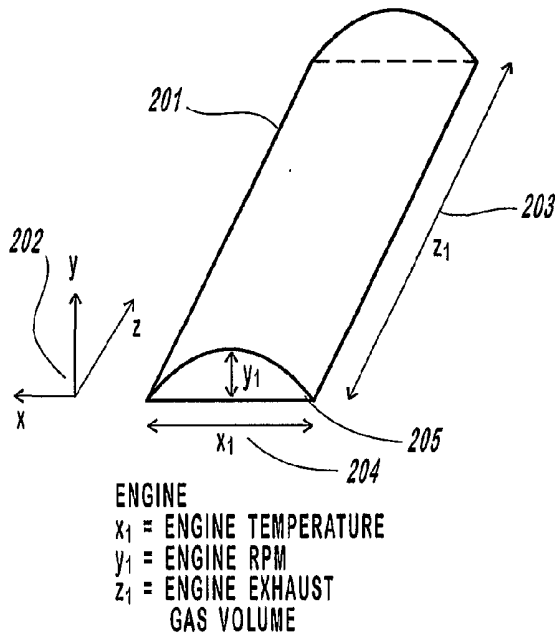

FIGURE 2a

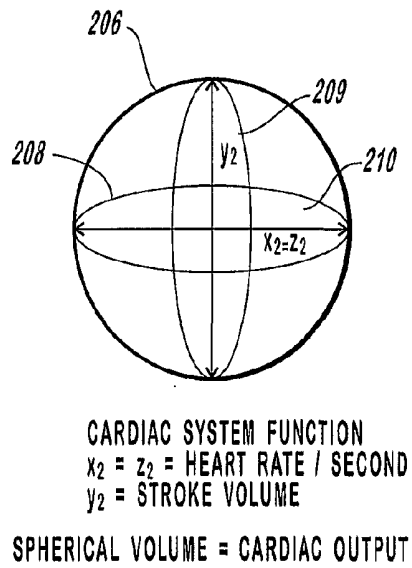

FIGURE 2b

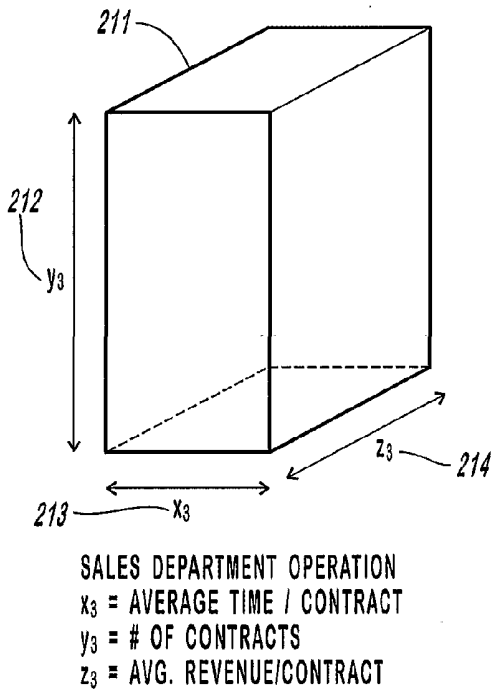

FIGURE 2c

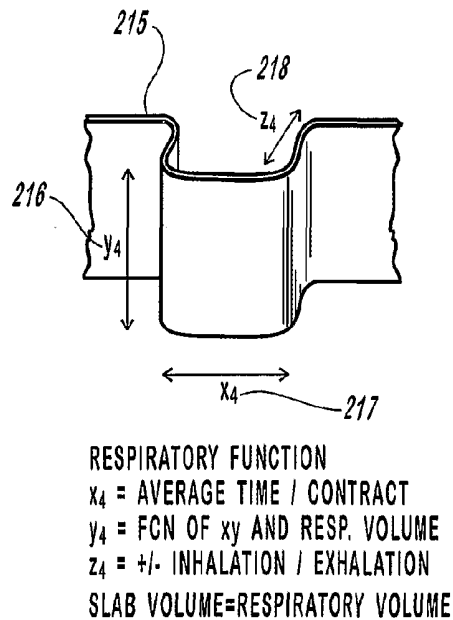

FIGURE 2d

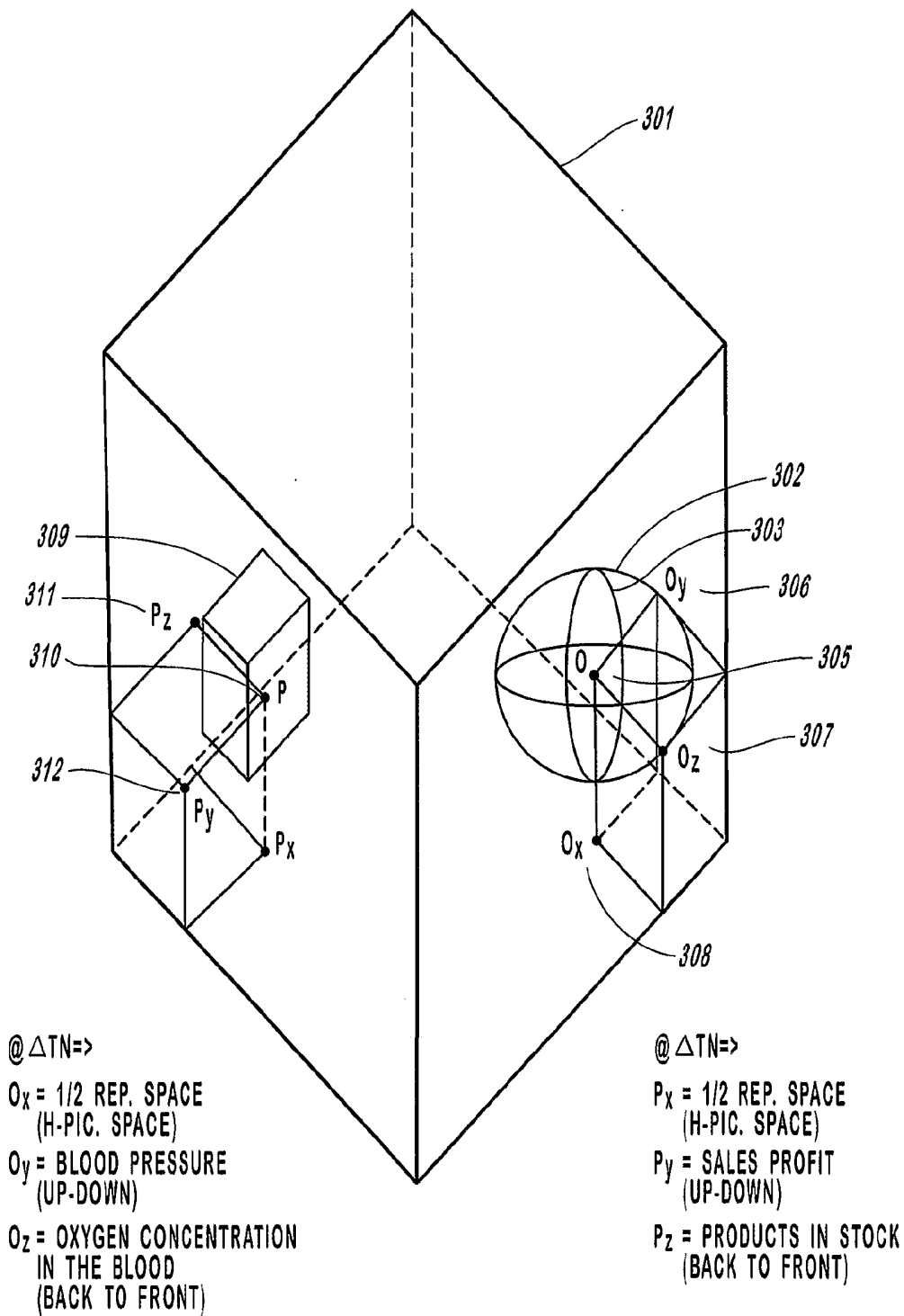

FIGURE 3

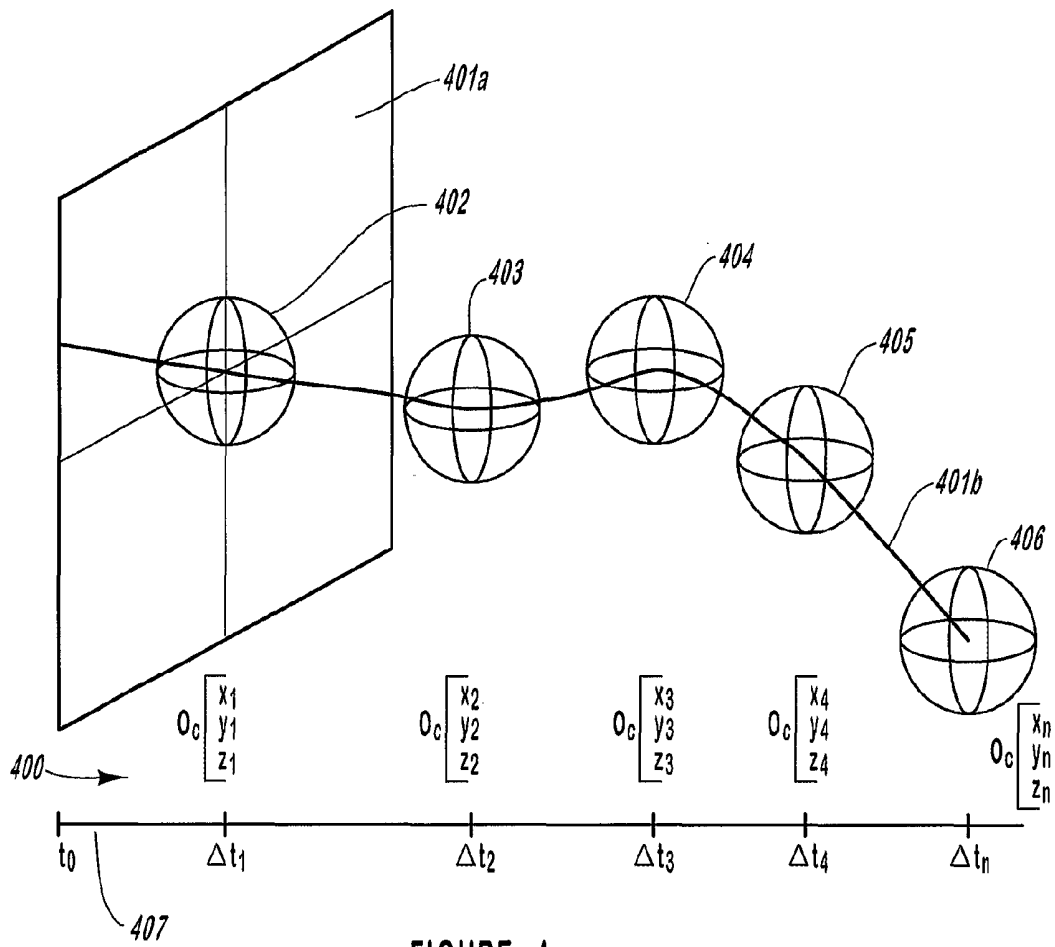

FIGURE 4a

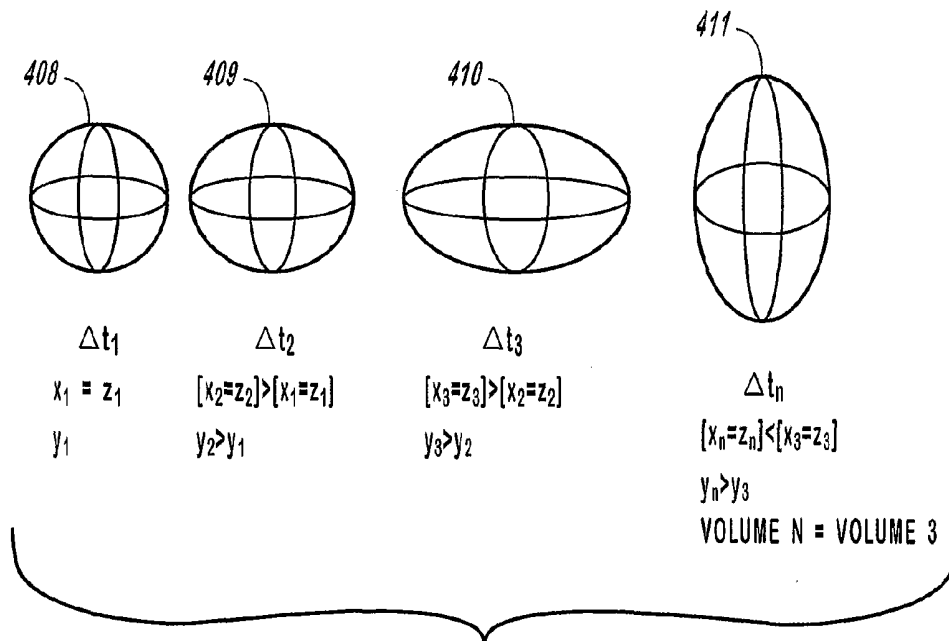

FIGURE 4b

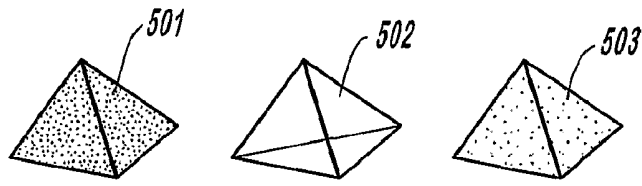

FIGURE 5a

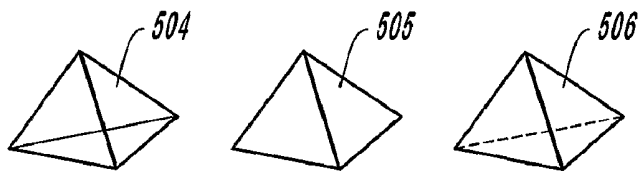

FIGURE 5b

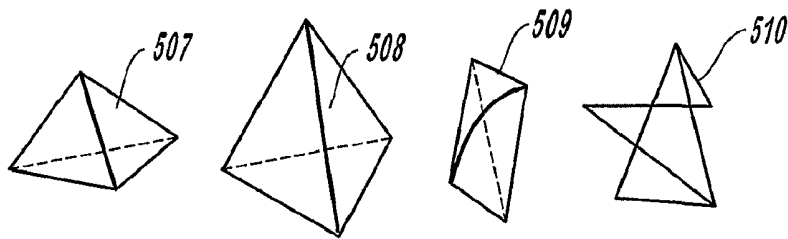

FIGURE 5c

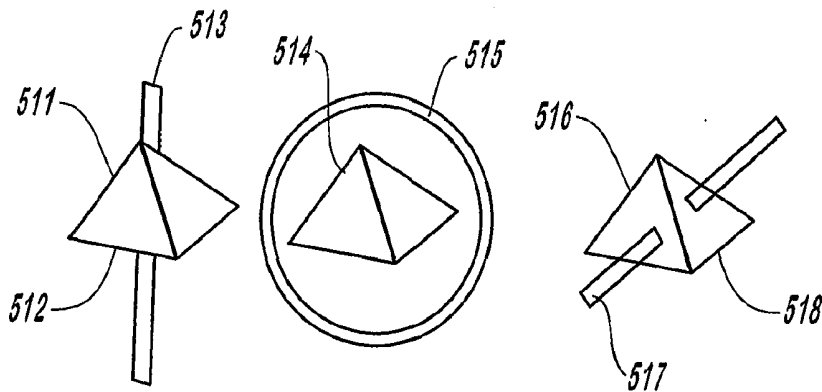

FIGURE 5d

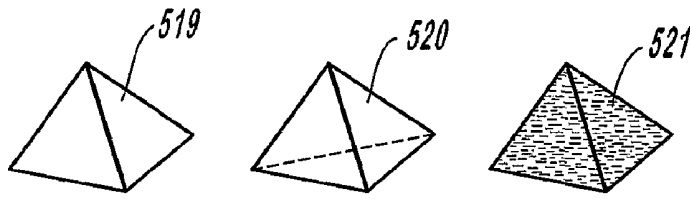

FIGURE 5e

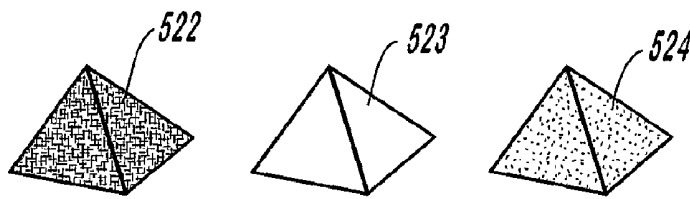

FIGURE 5f

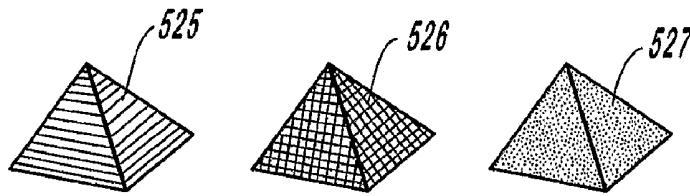

FIGURE 5g

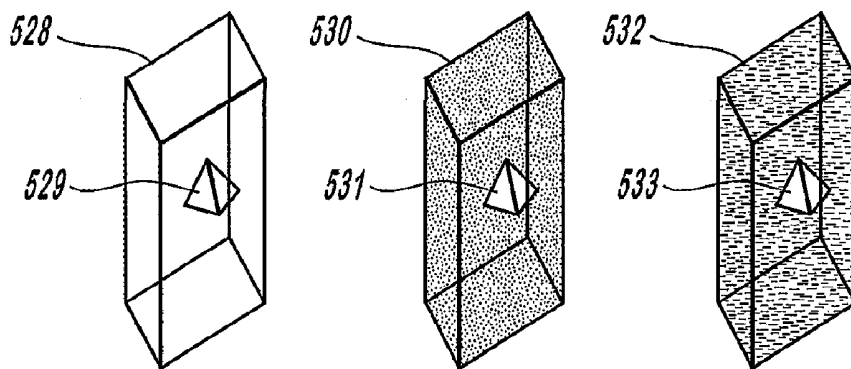

FIGURE 5h

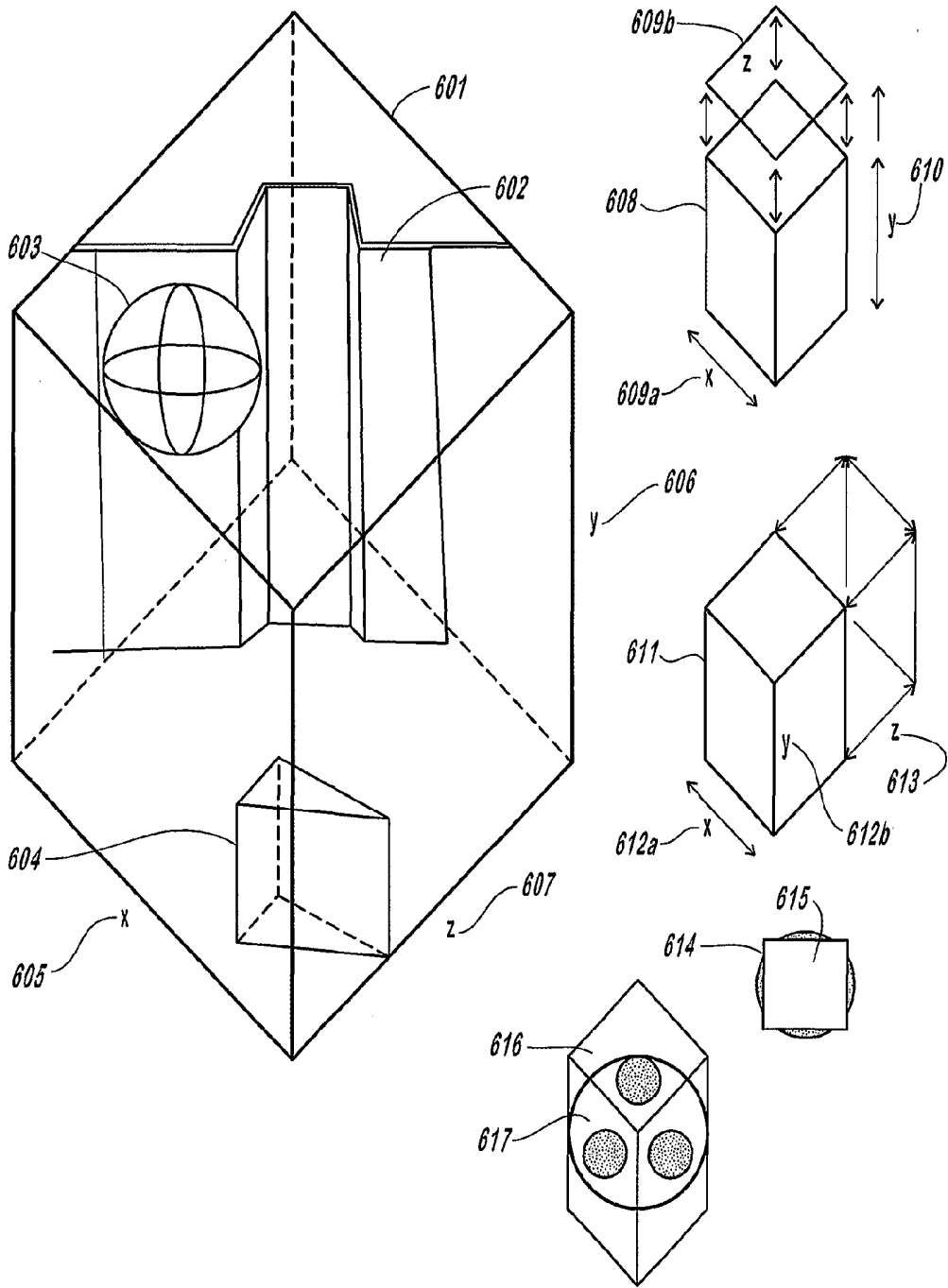

FIGURE 6

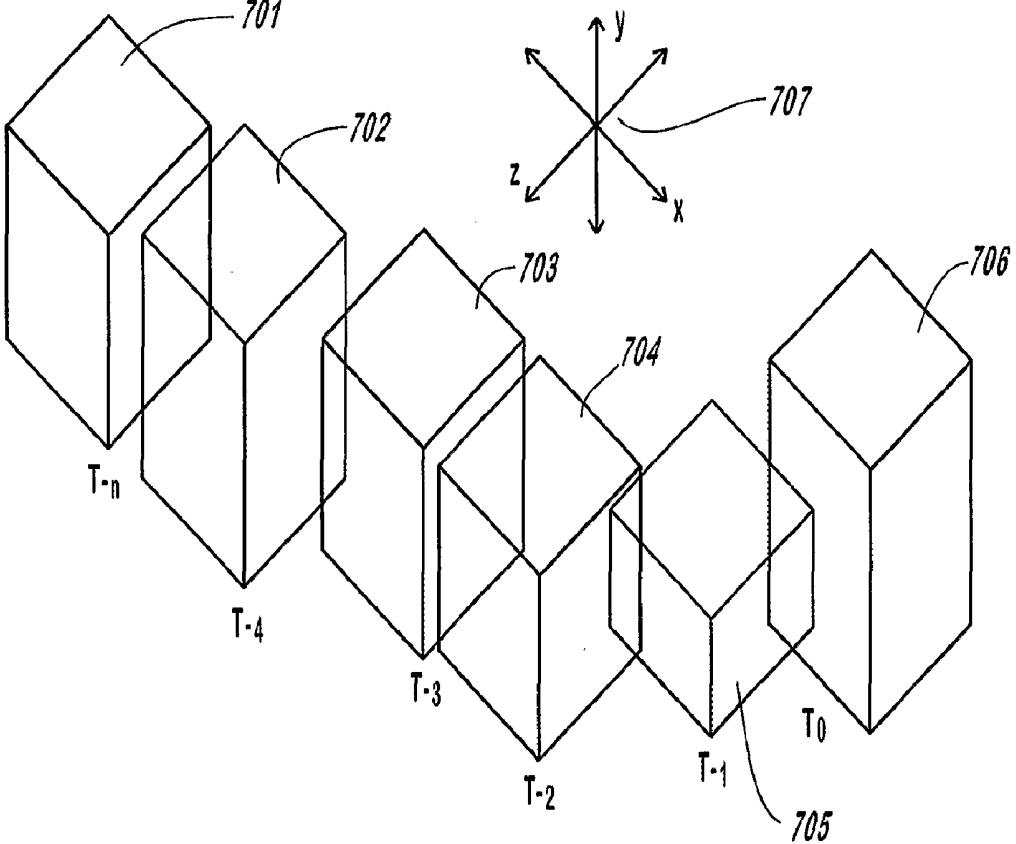

FIGURE 7

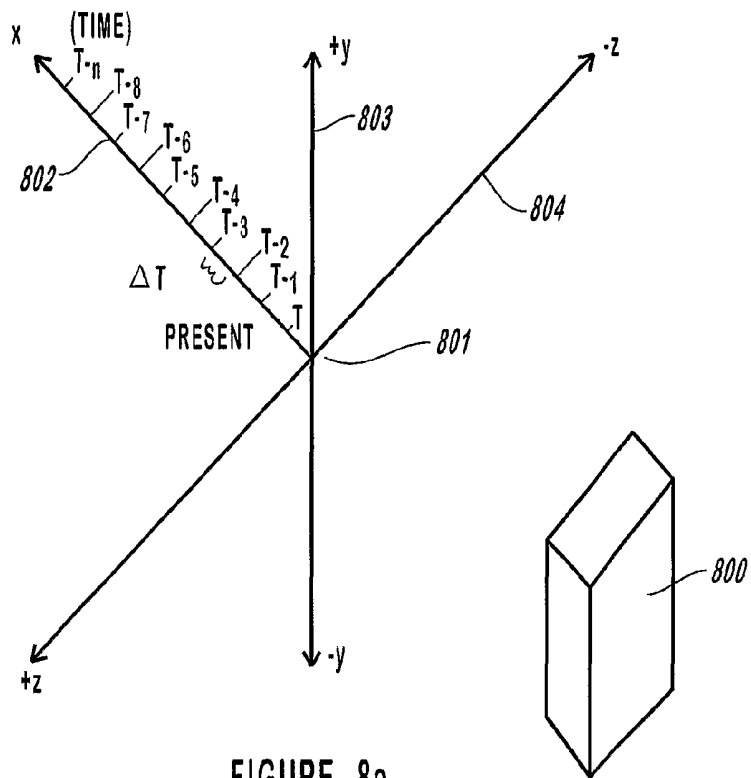

FIGURE 8a

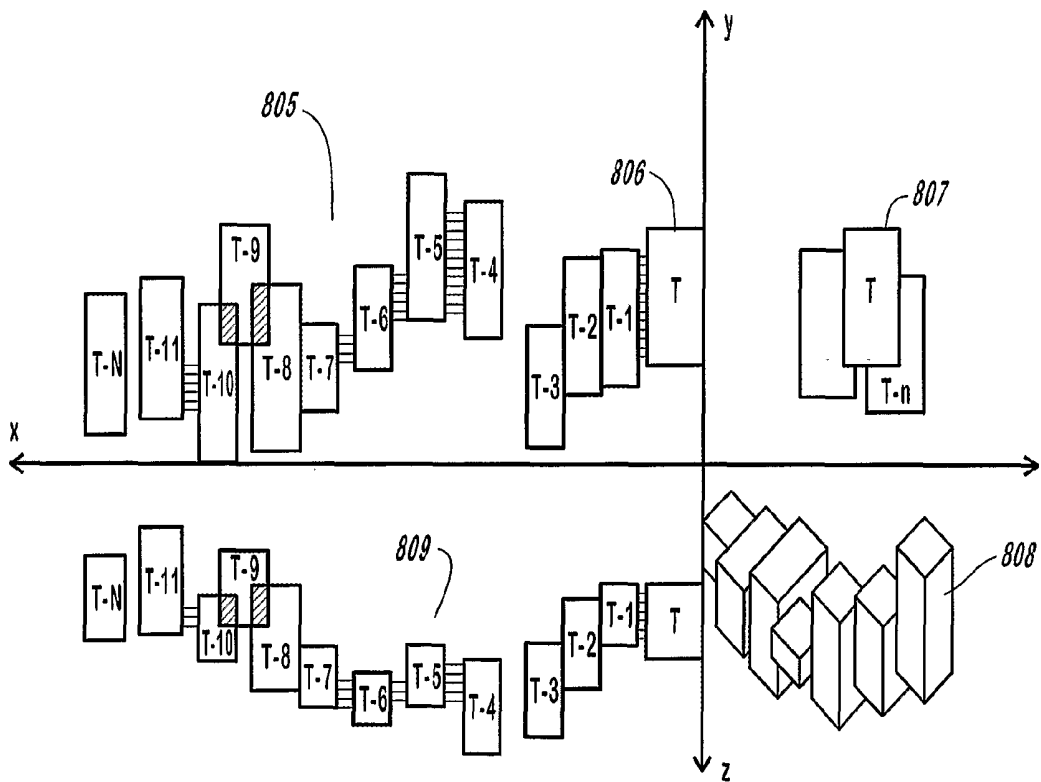

FIGURE 8b

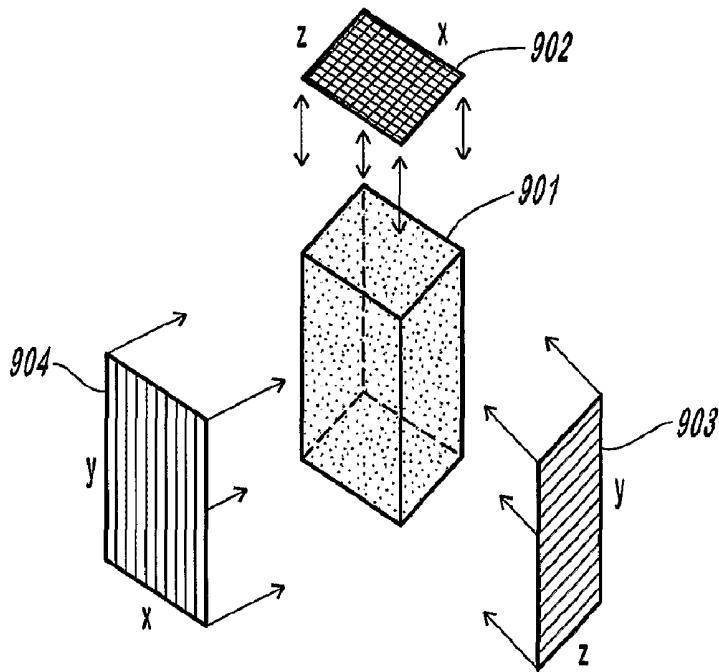

FIGURE 9a

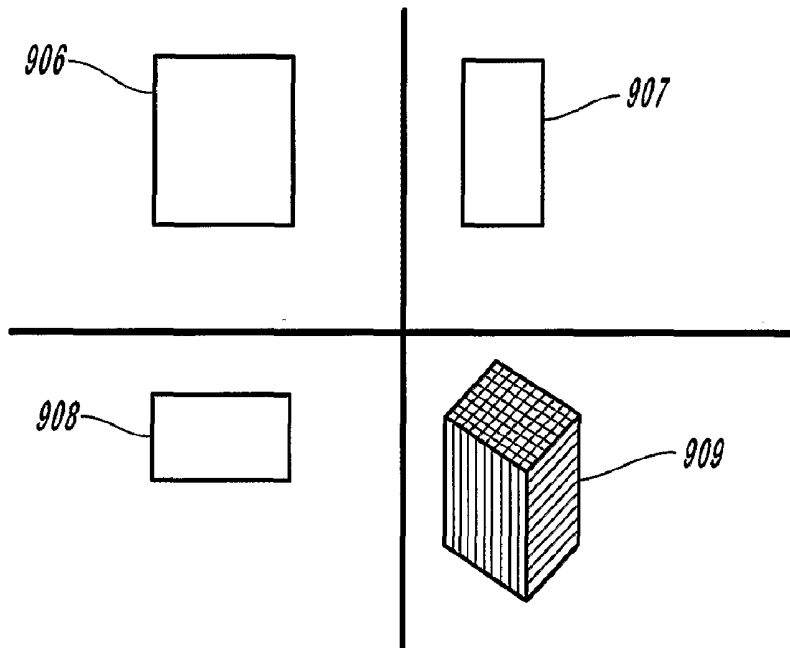

FIGURE 9b

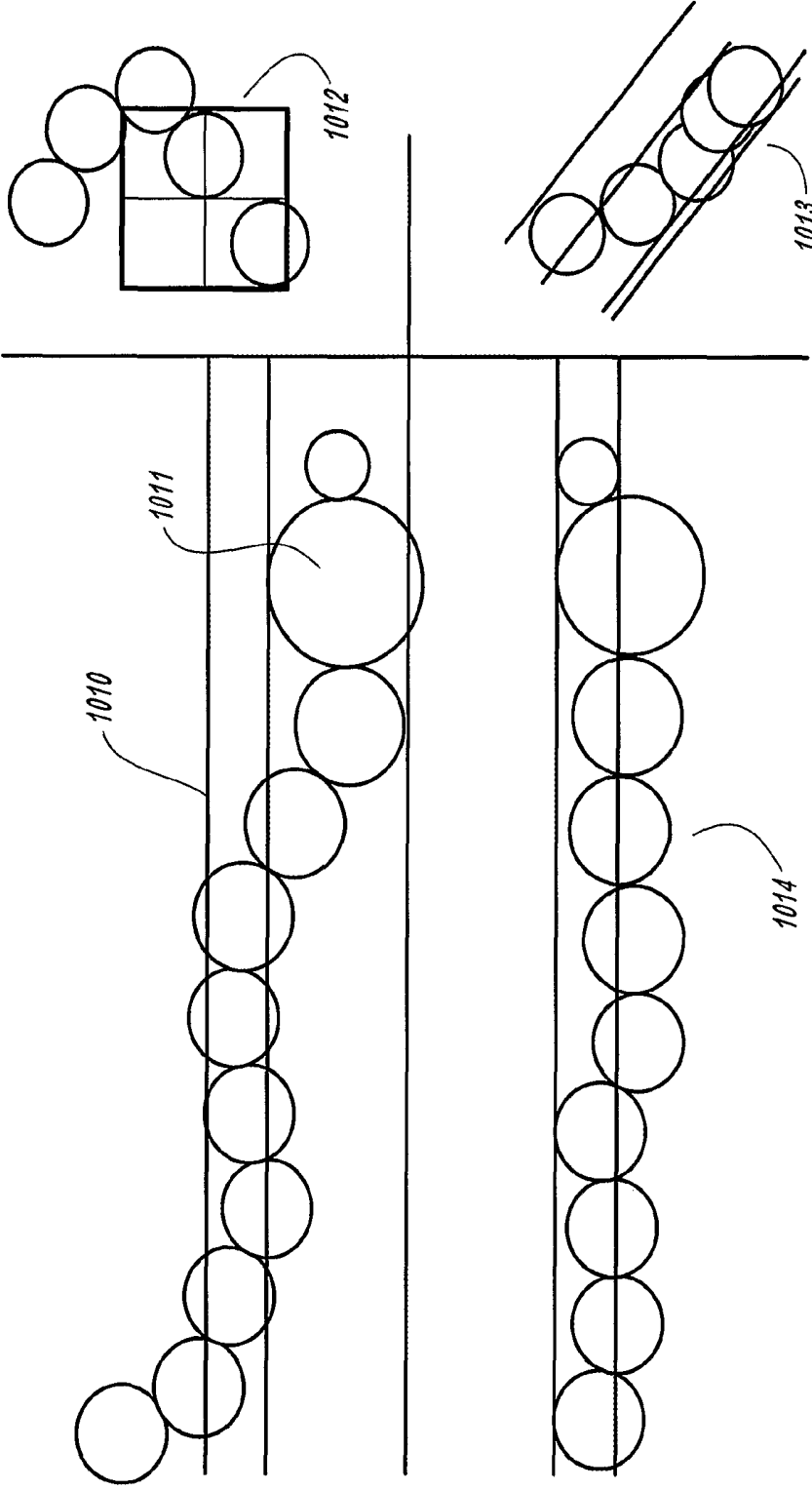

FIGURE 10

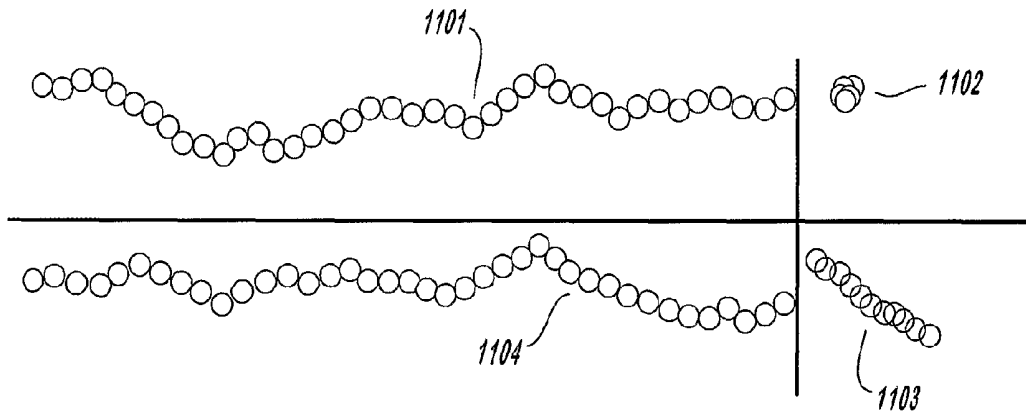

FIGURE 11a

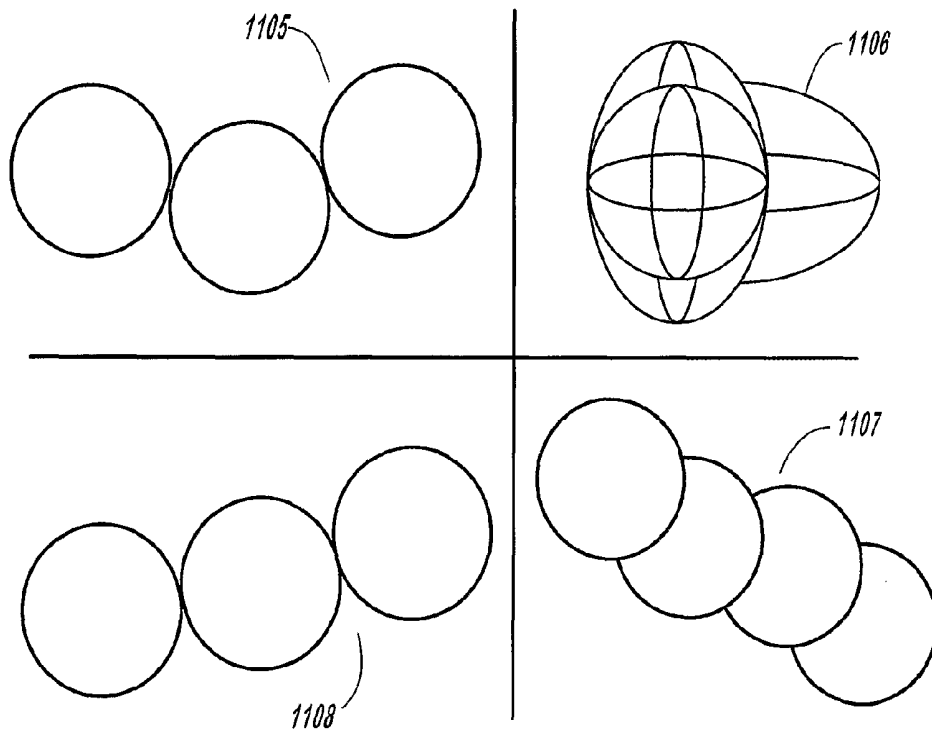

FIGURE 11b

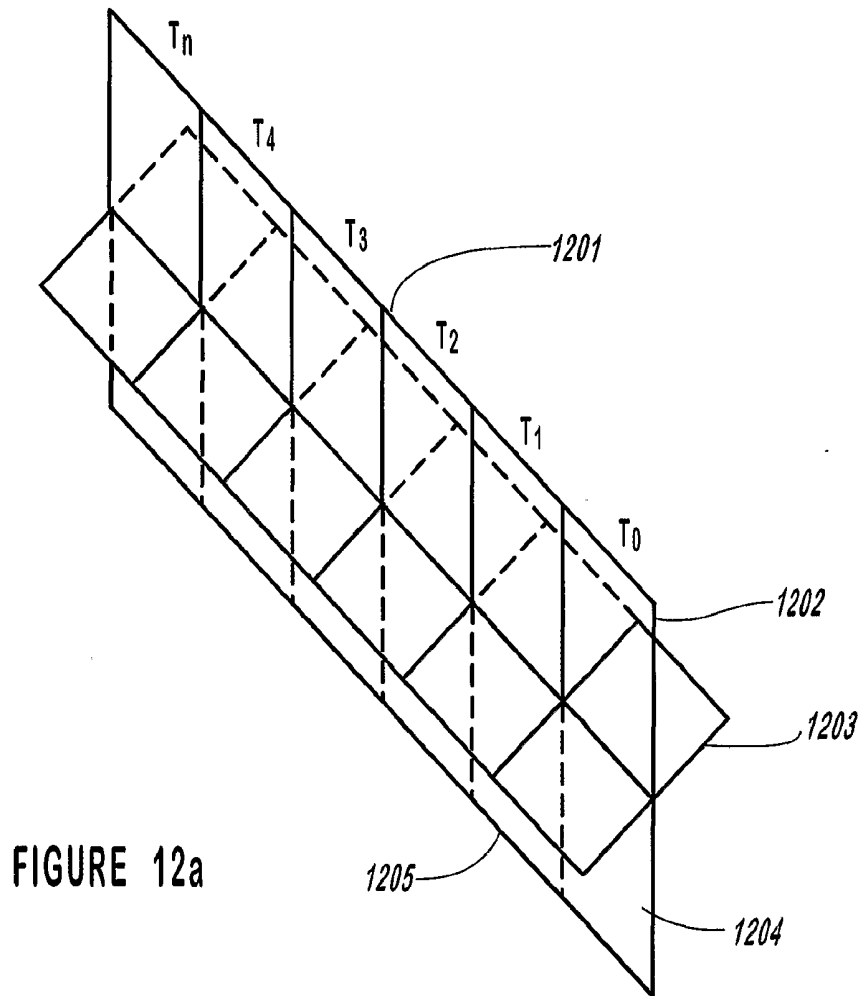

FIGURE 12a

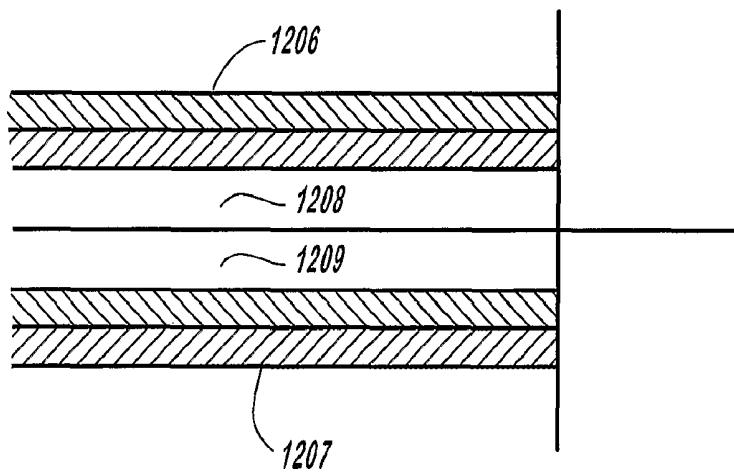
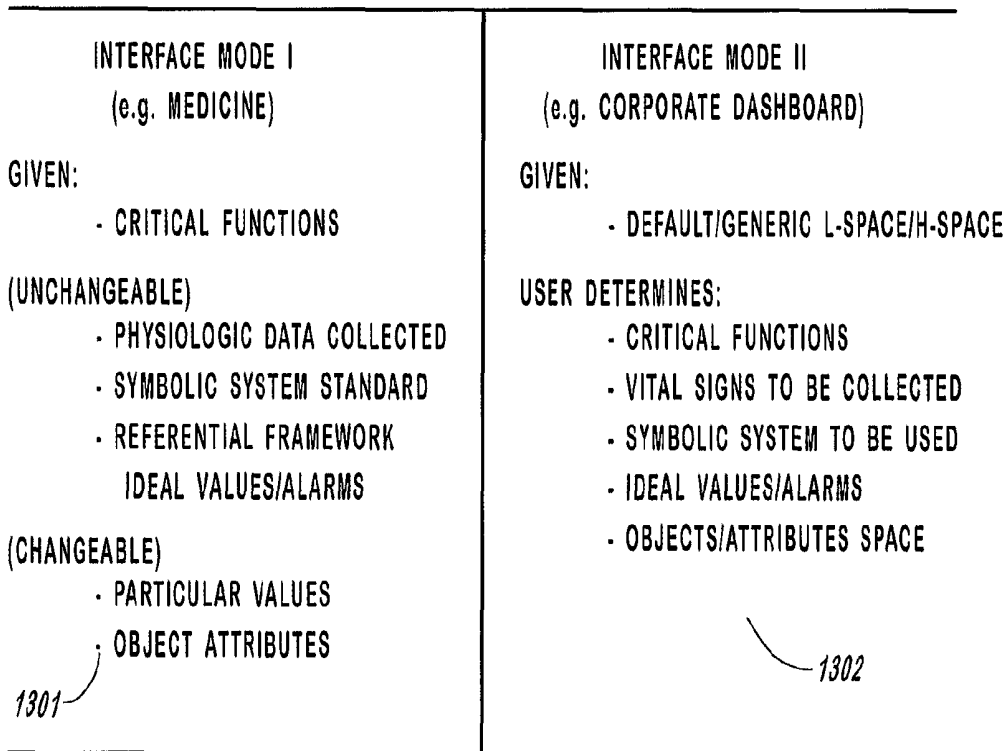

FIGURE 12b



COMMON INTERFACE FEATURES

- L-SPACE
- H-SPACE
- ZOOM/SPEED
- VIEWPOINTS

FIGURE 13

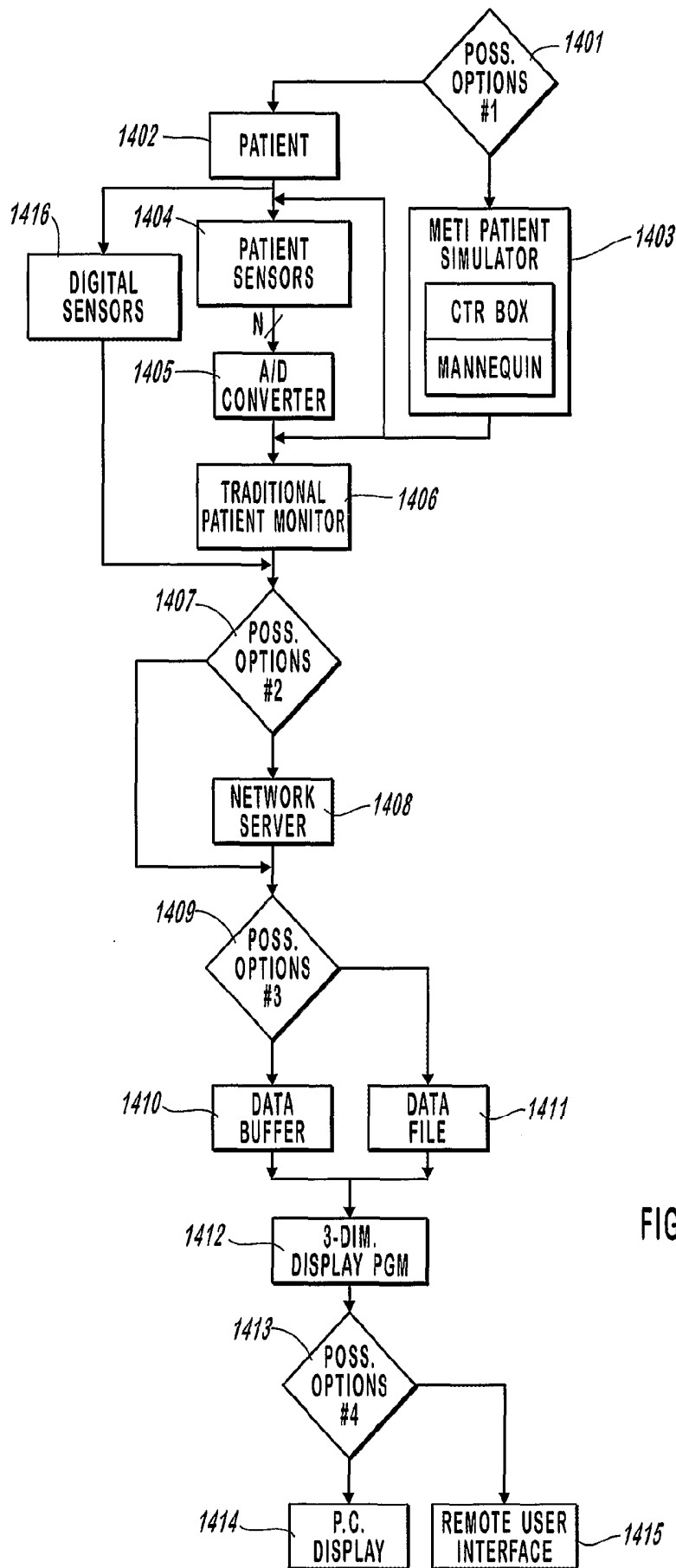

FIGURE 14

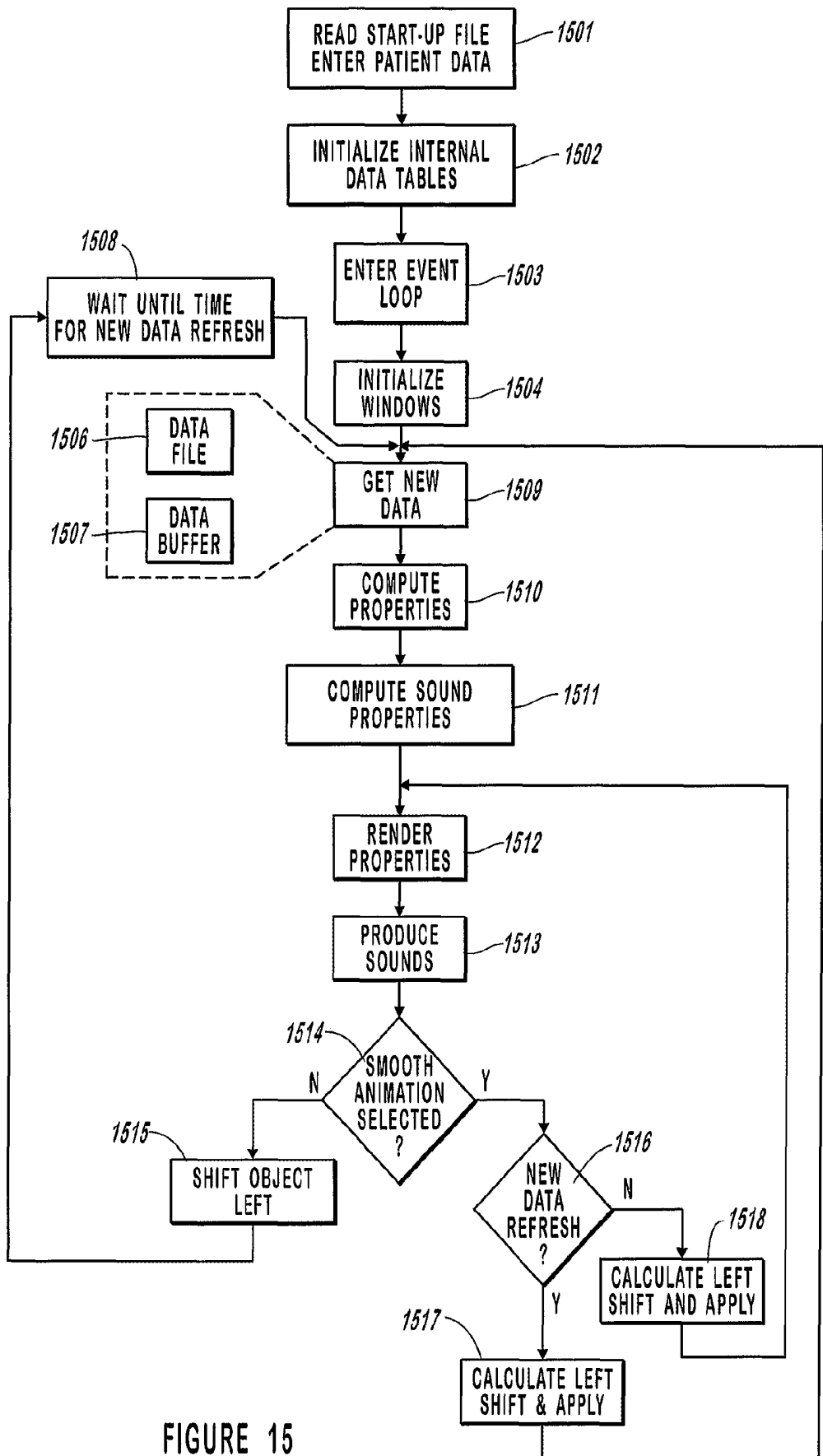

FIGURE 15

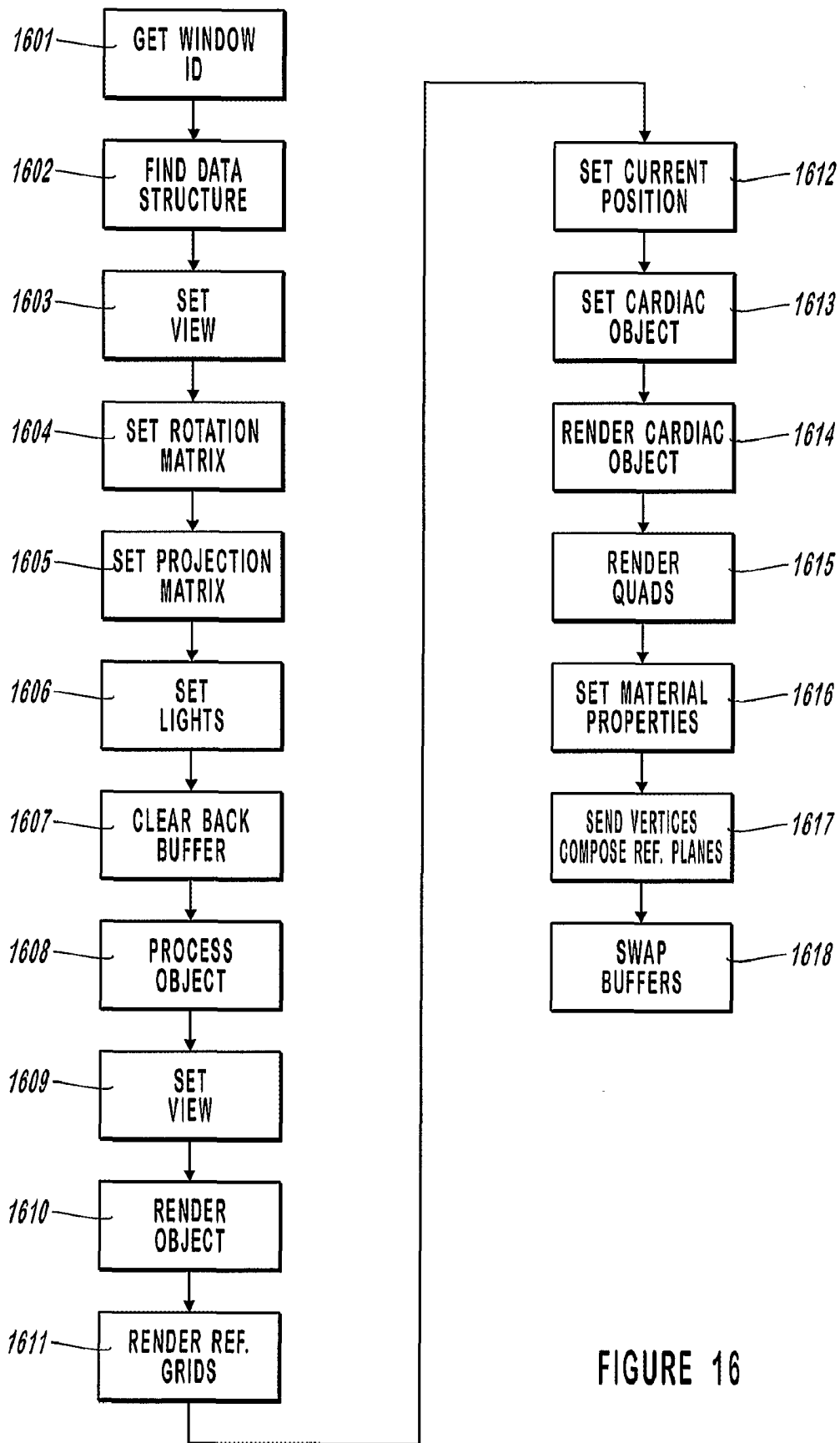

FIGURE 16

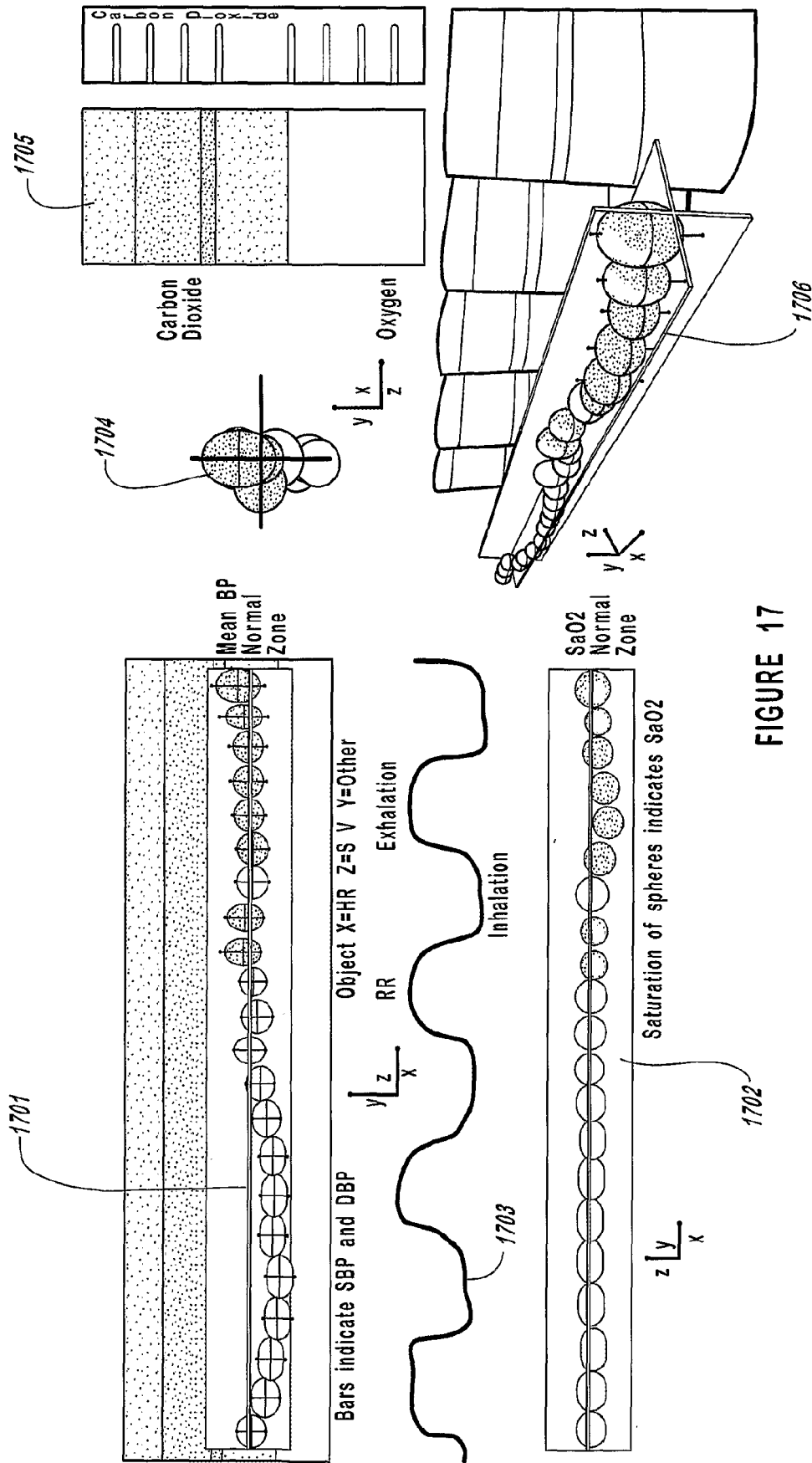

FIGURE 17

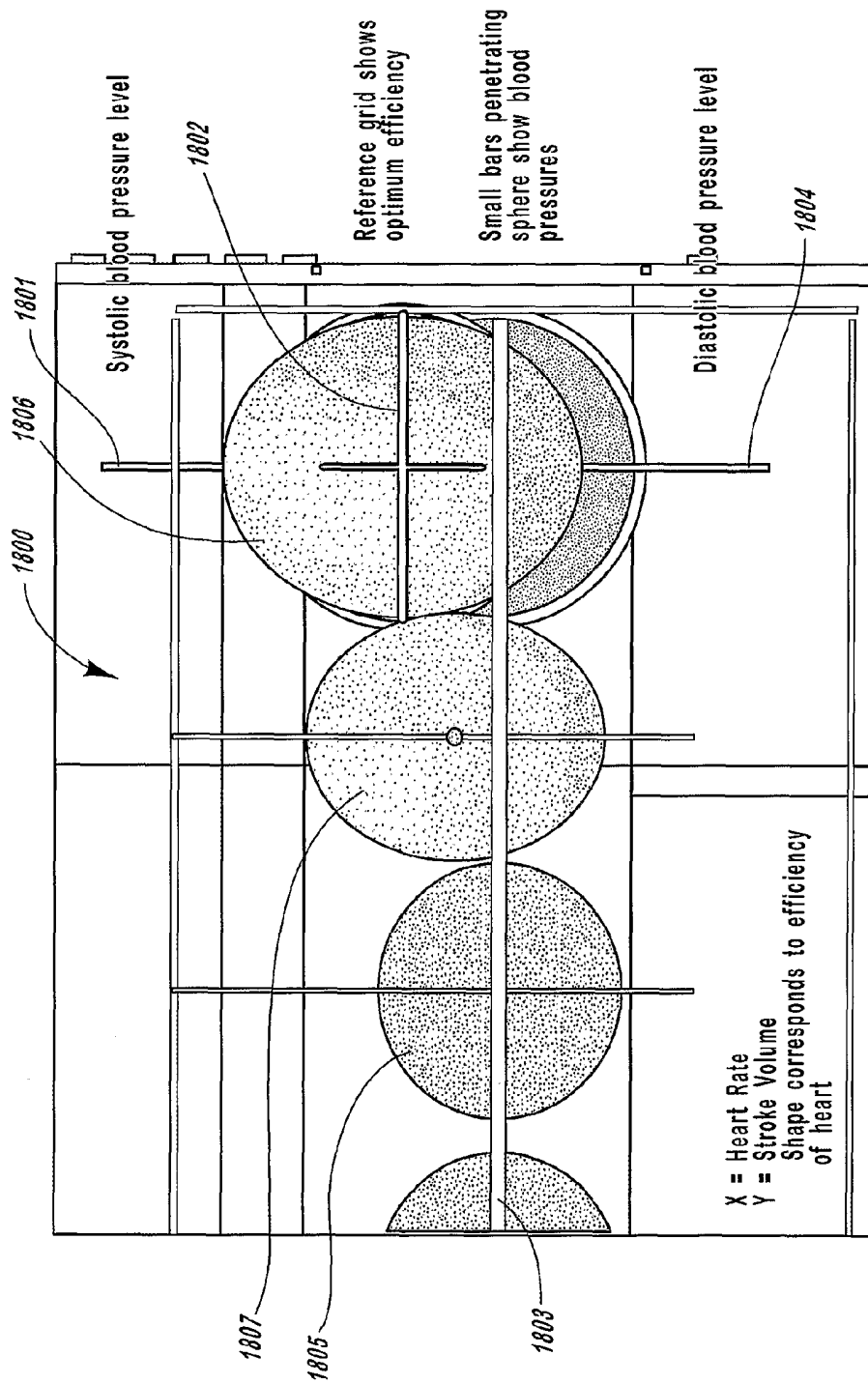

FIGURE 18

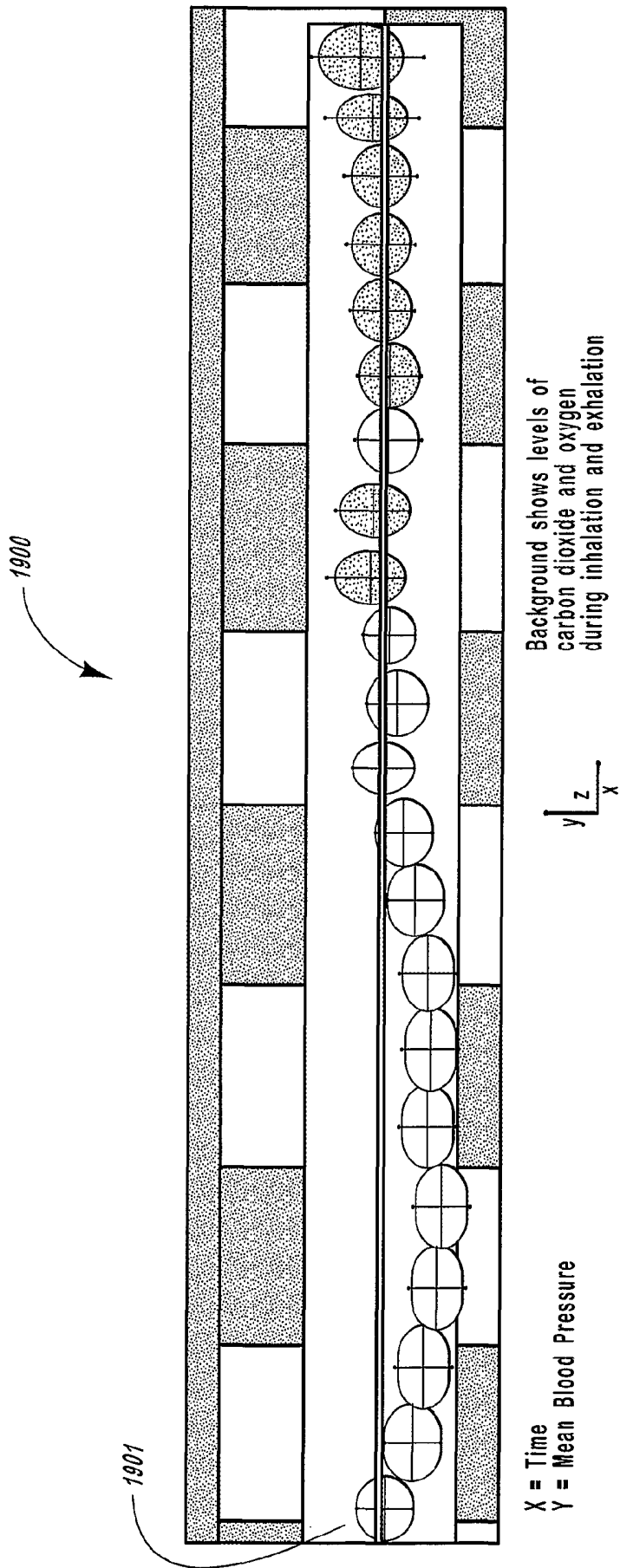

FIGURE 19

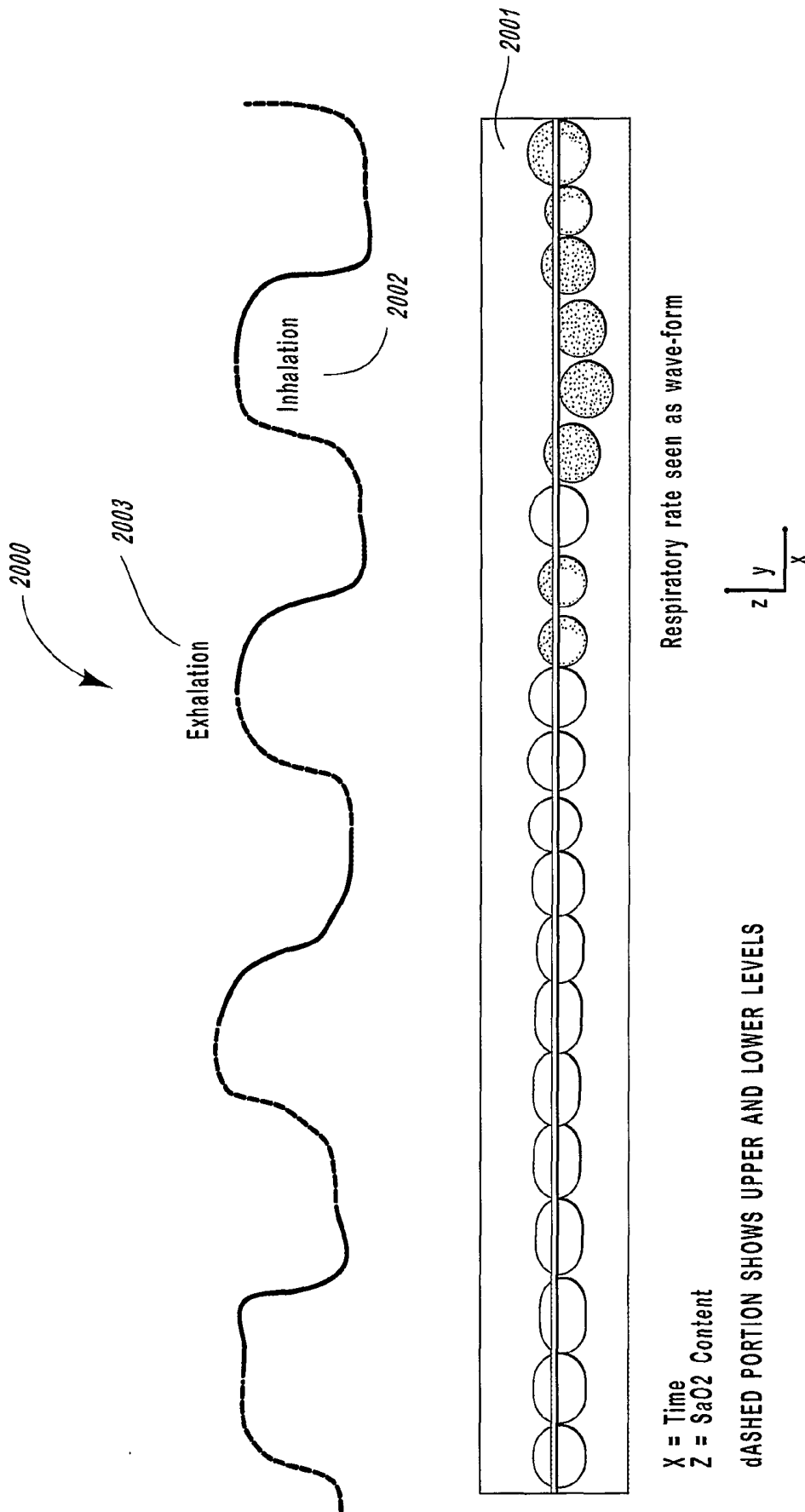

FIGURE 20



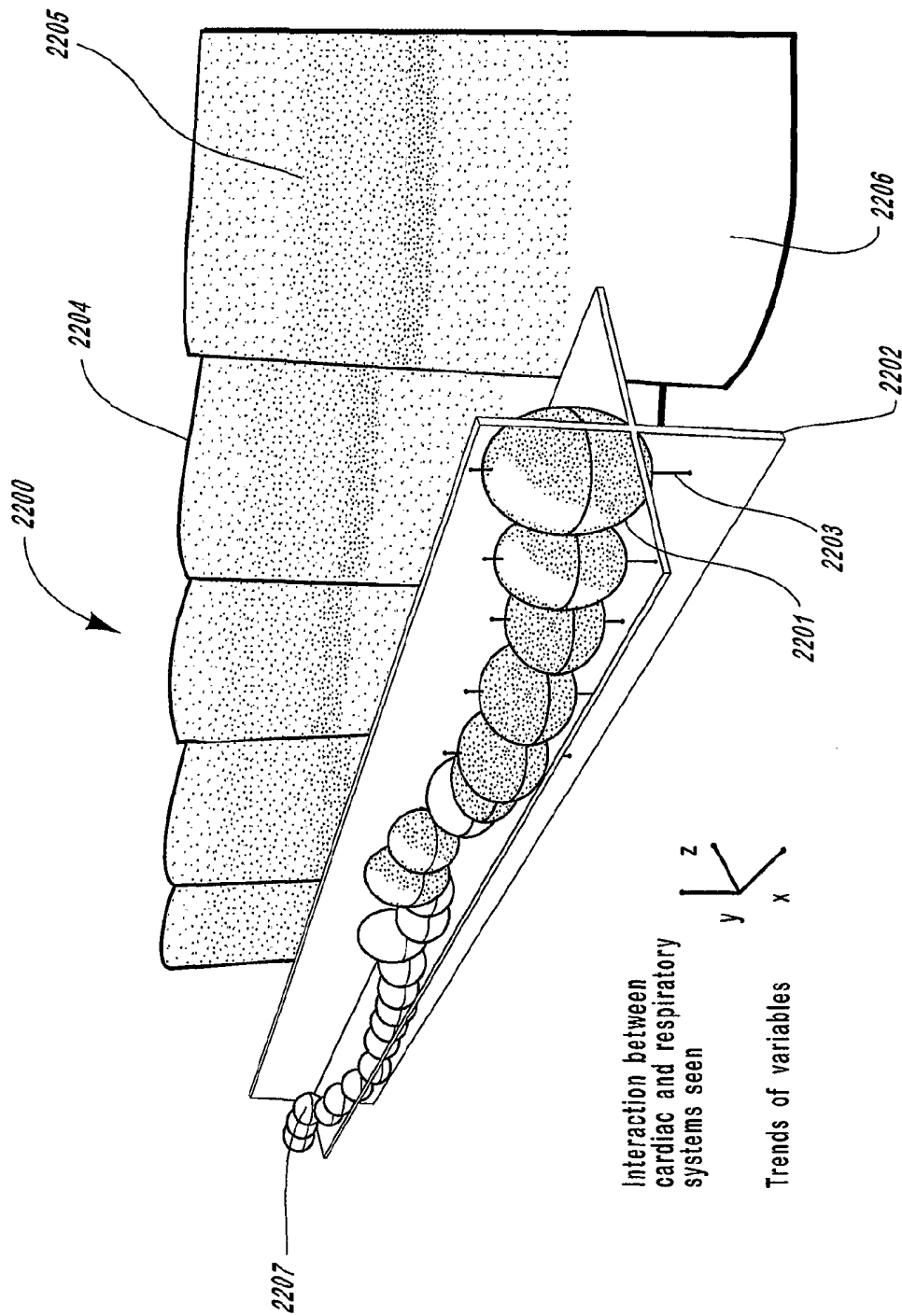

FIGURE 22

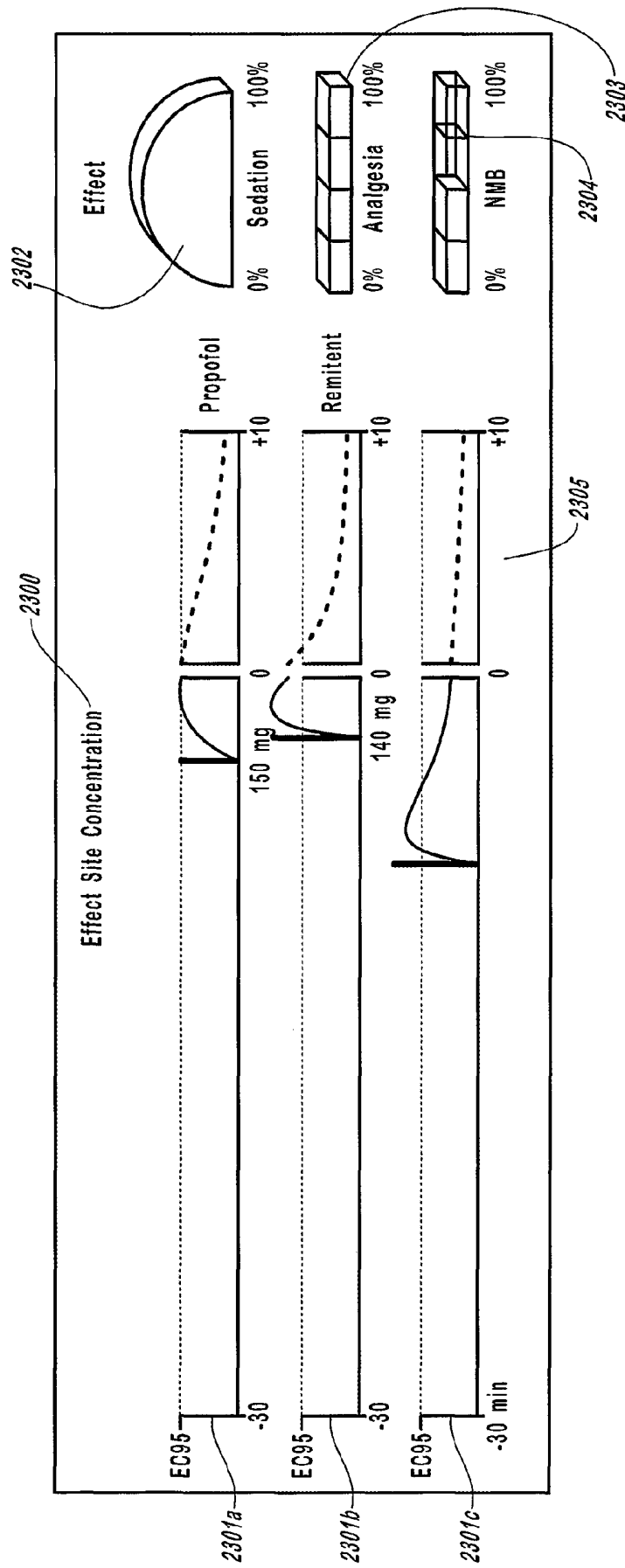

FIGURE 23

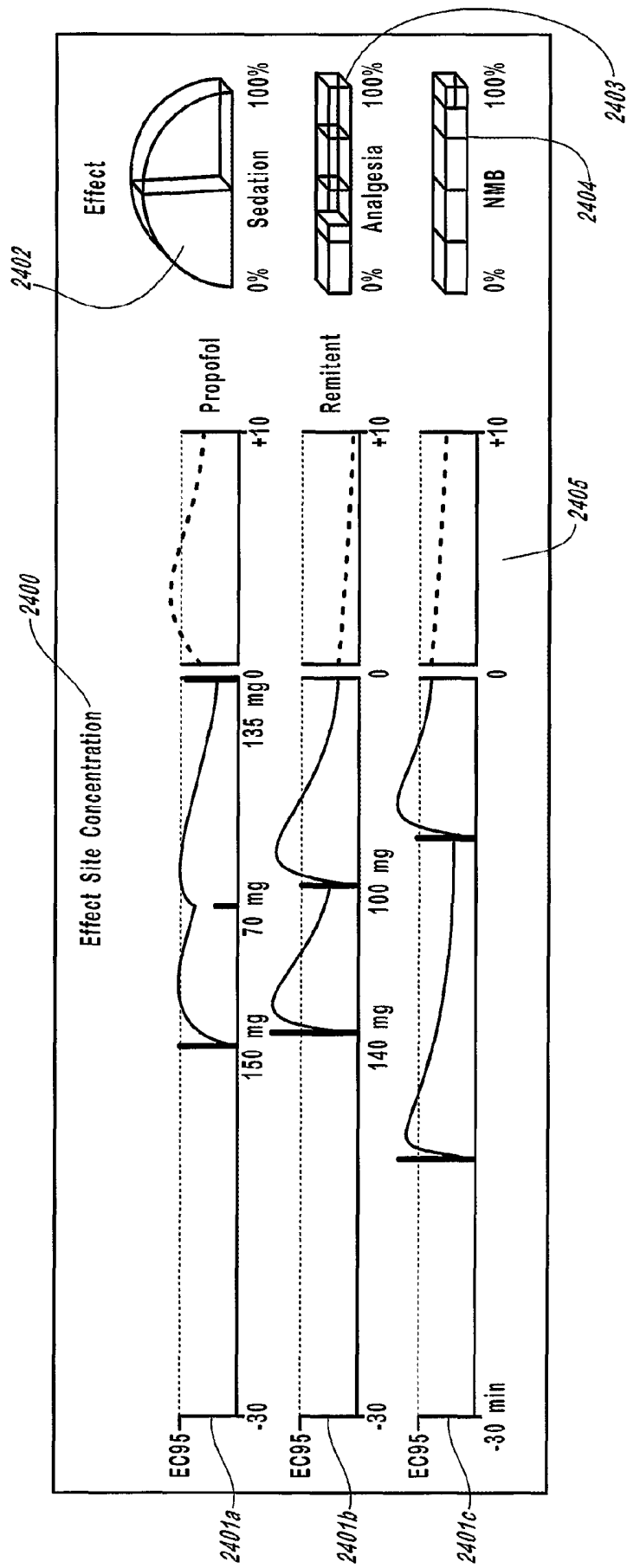

FIGURE 24

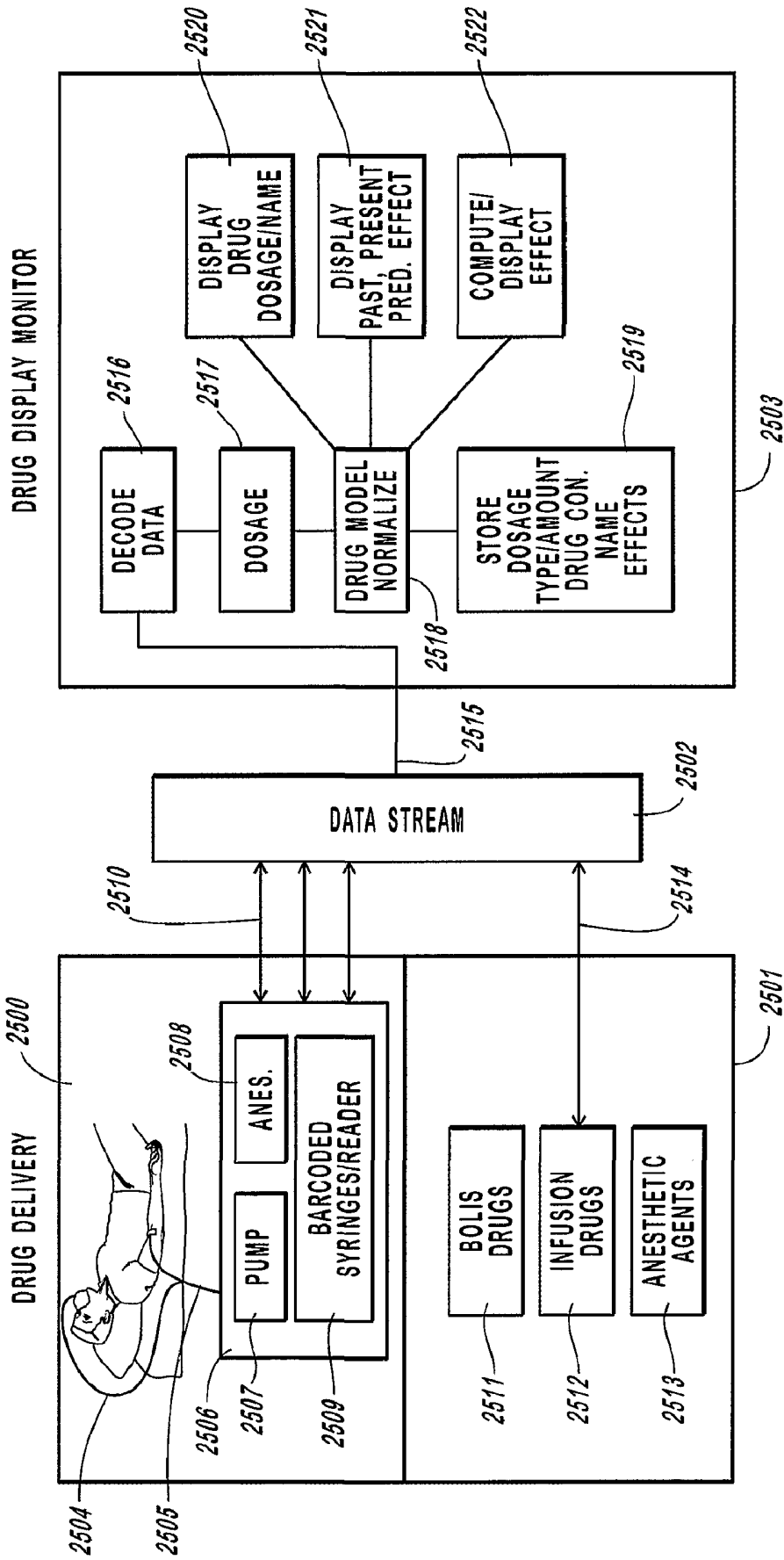

FIGURE 25

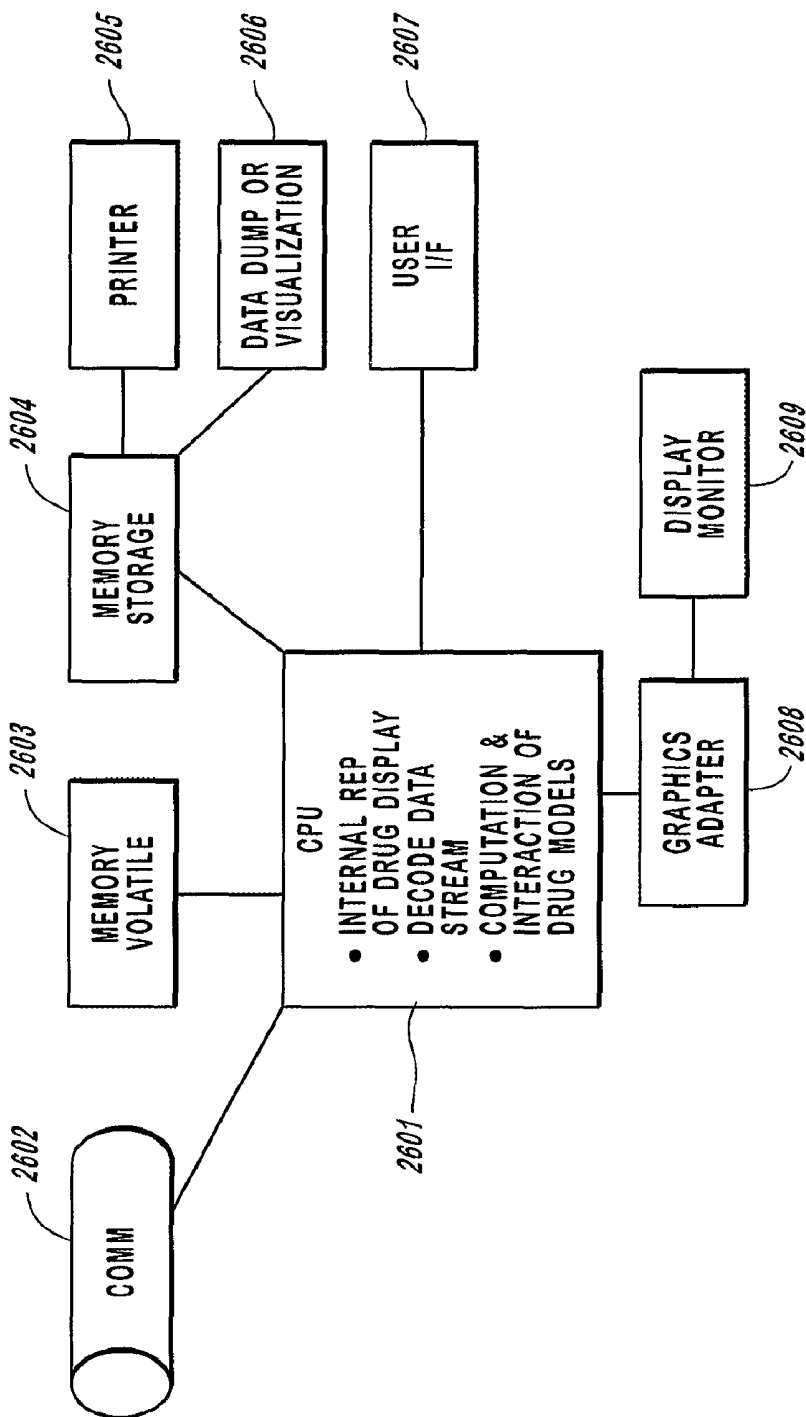

FIGURE 26

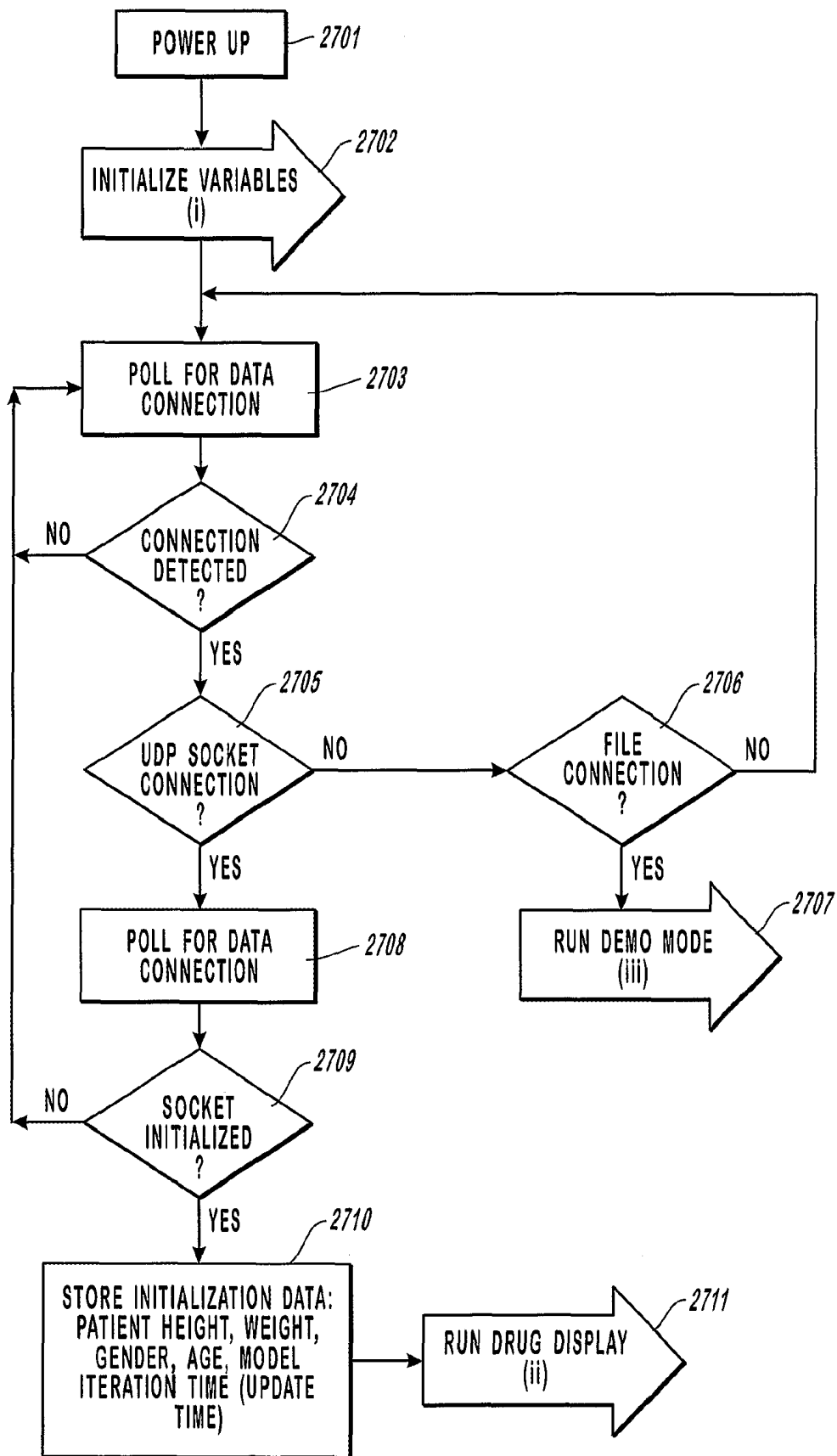

FIGURE 27

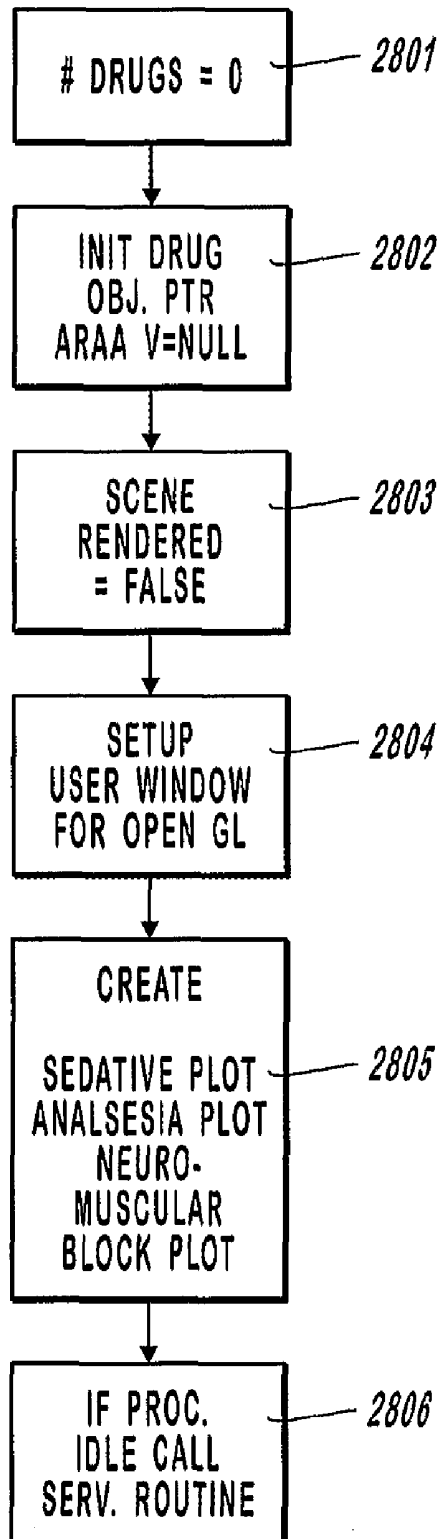

FIGURE 28

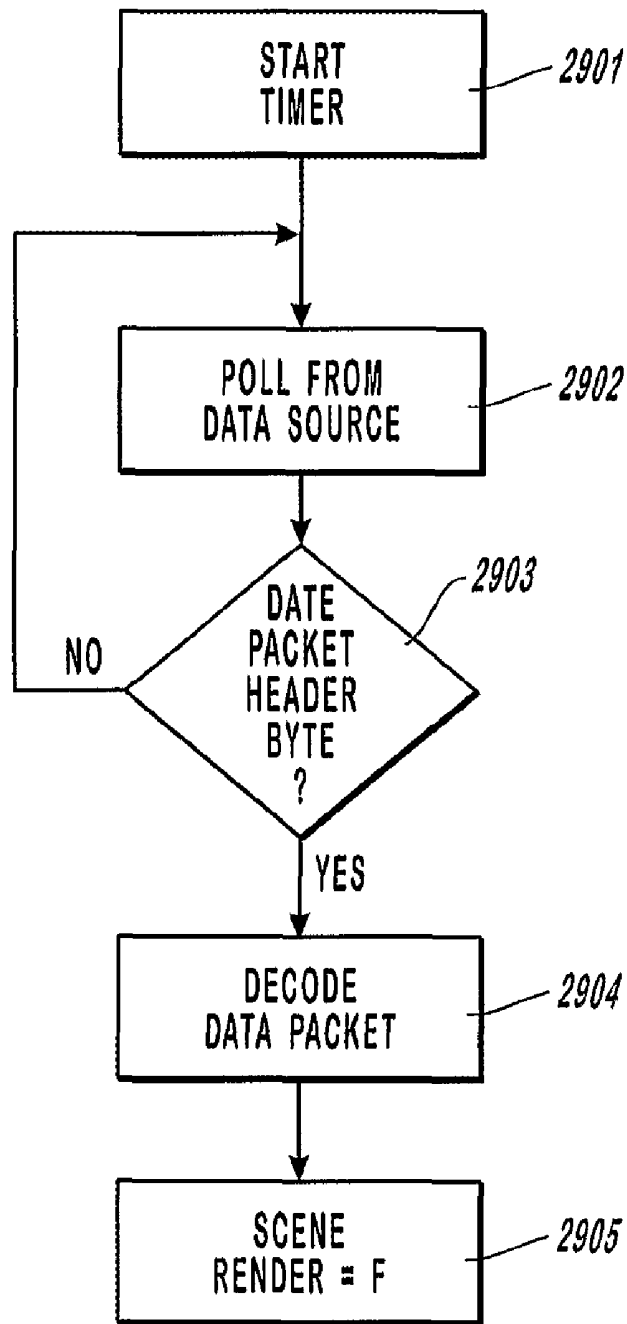

FIGURE 29

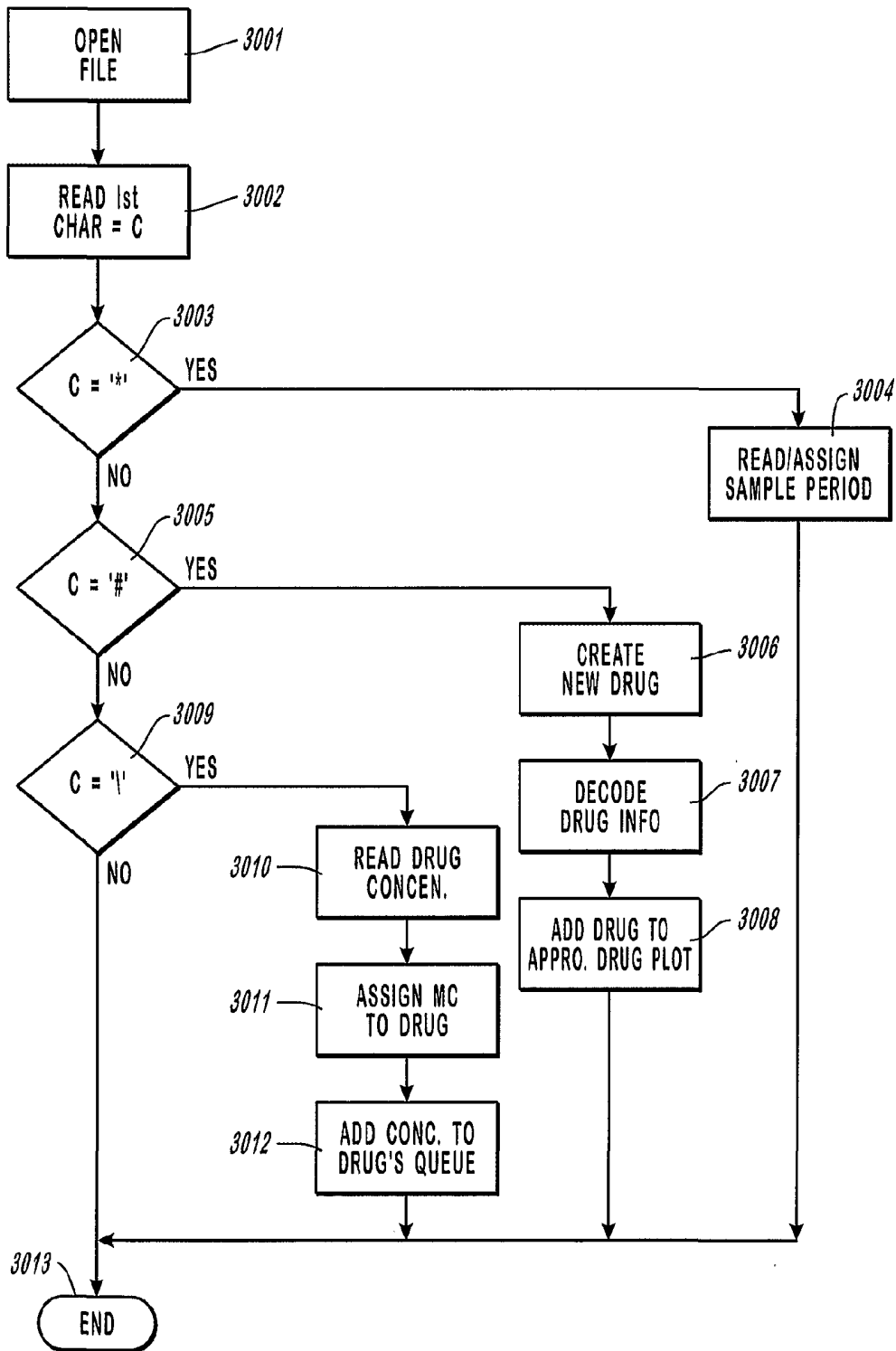

FIGURE 30

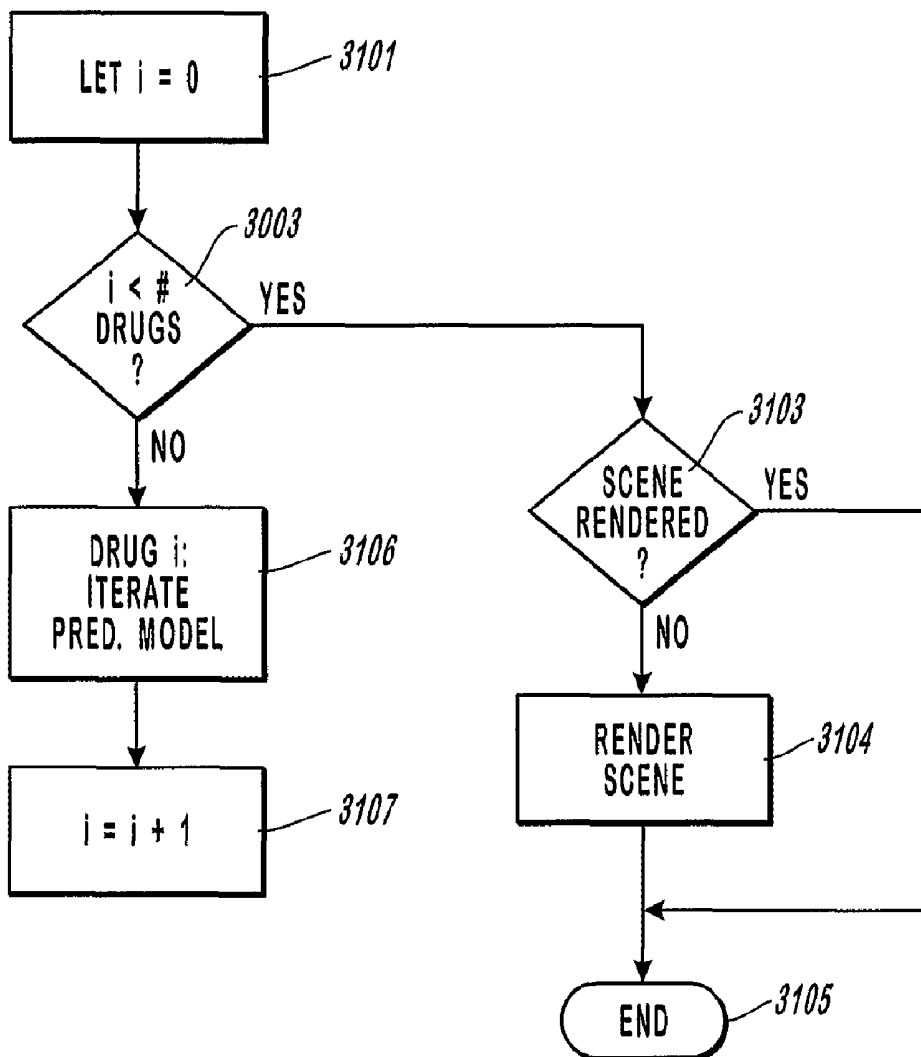

FIGURE 31

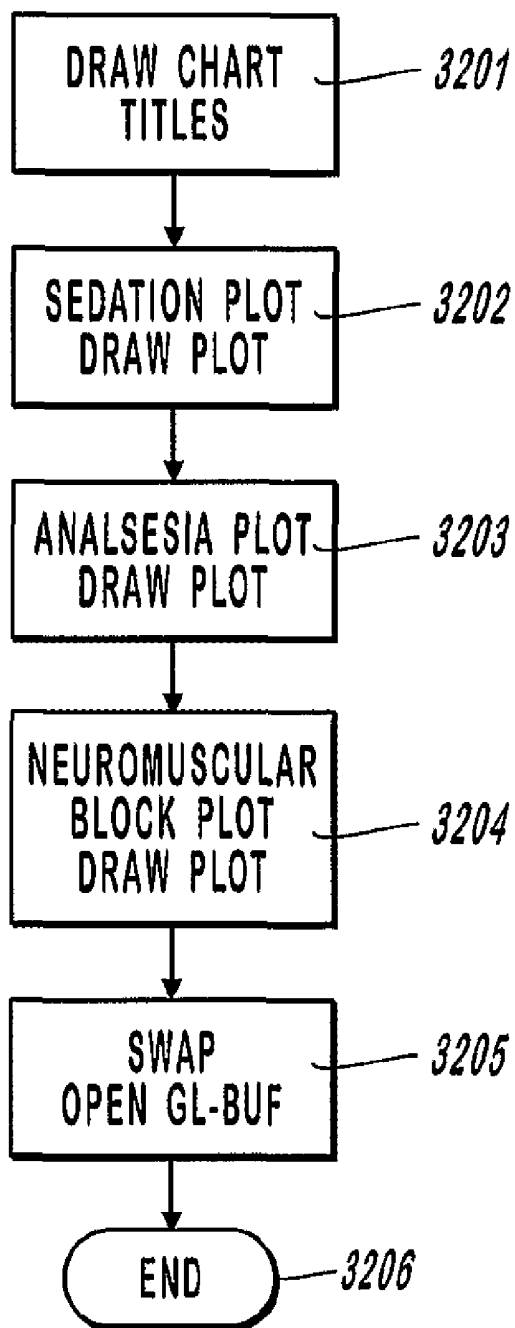

FIGURE 32

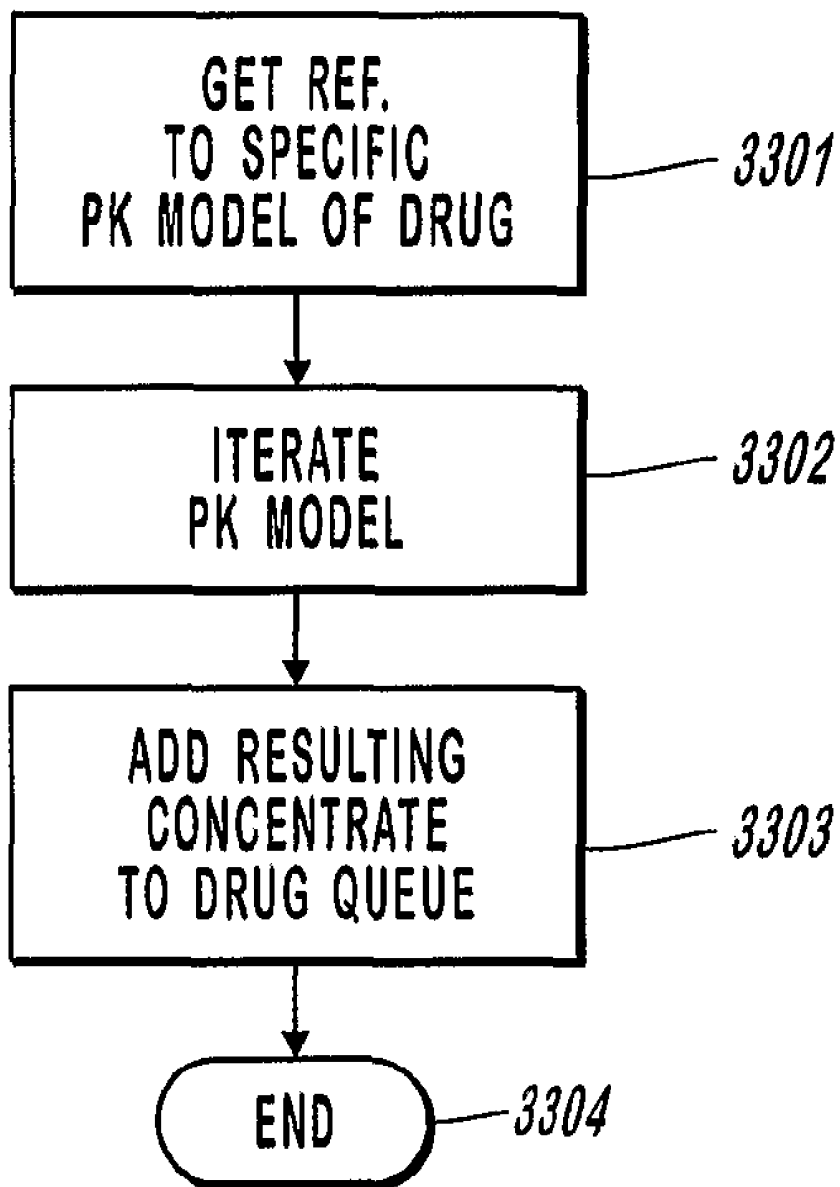

FIGURE 33

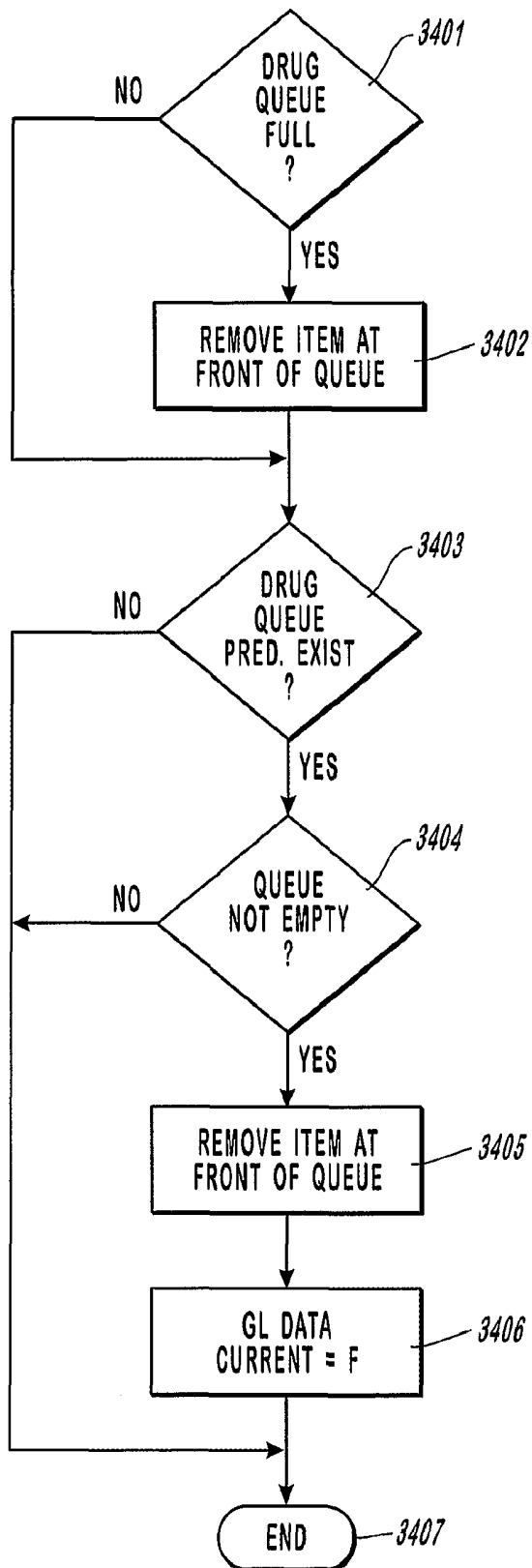

FIGURE 34

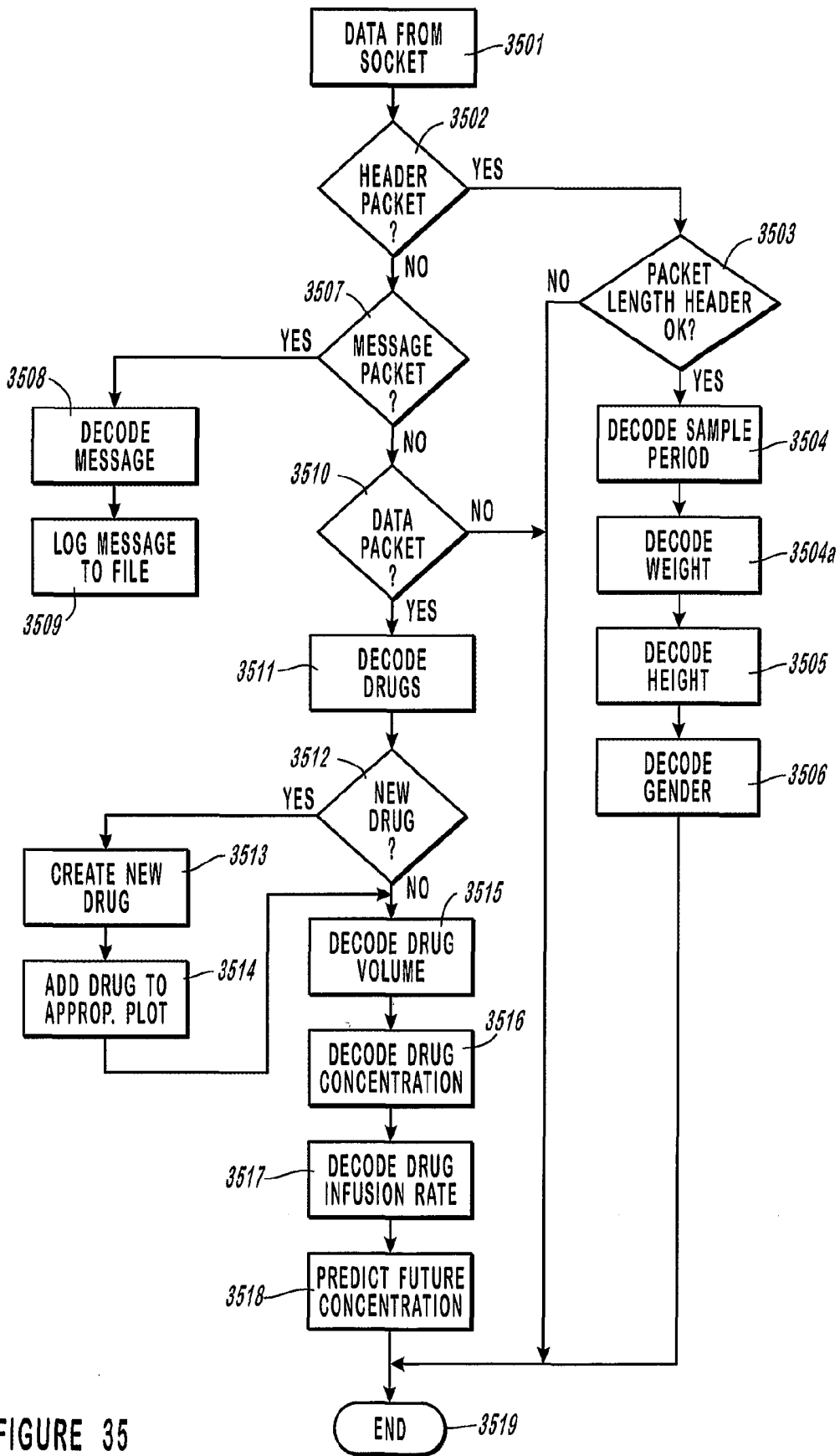

FIGURE 35

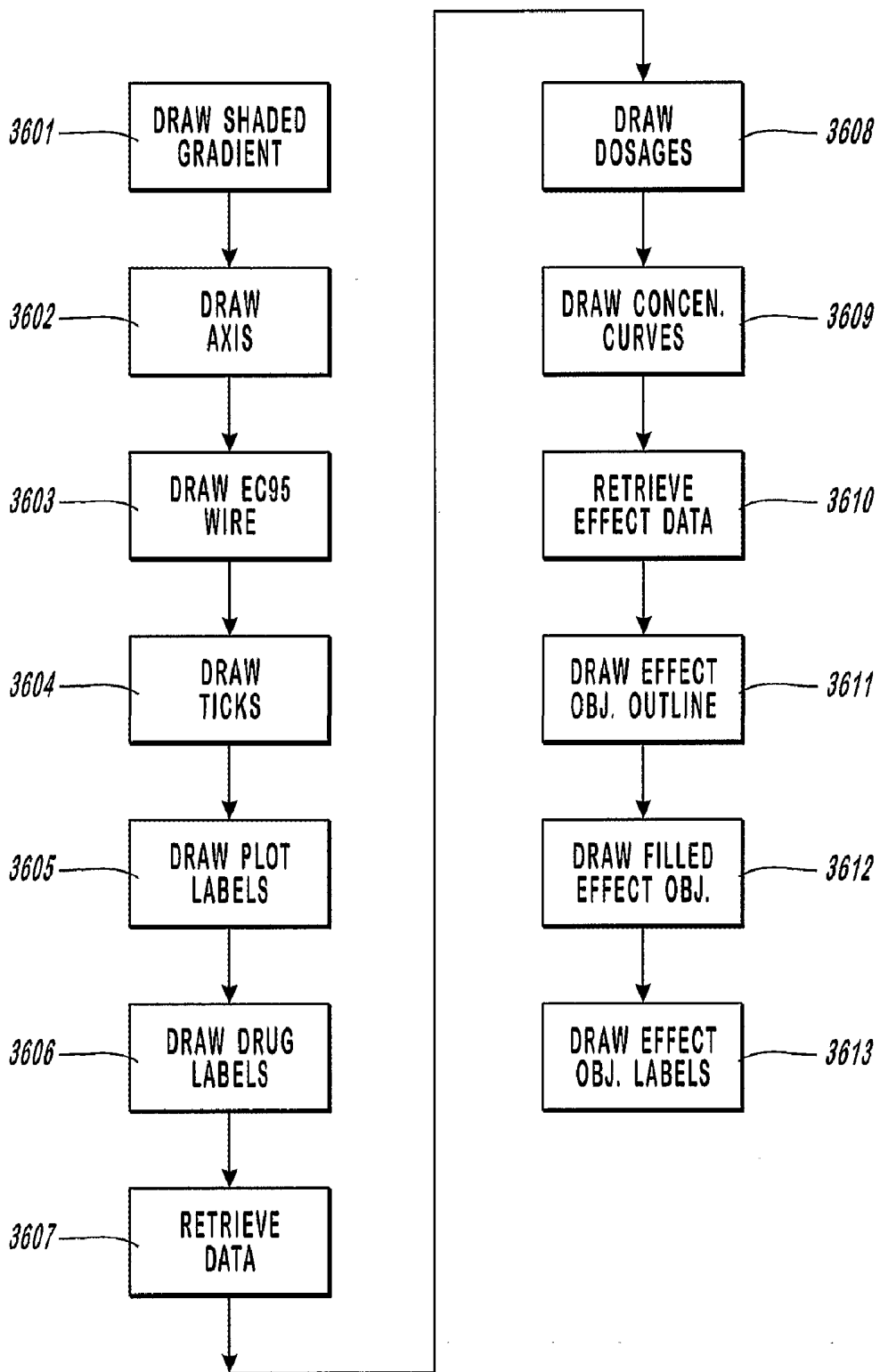

FIGURE 36

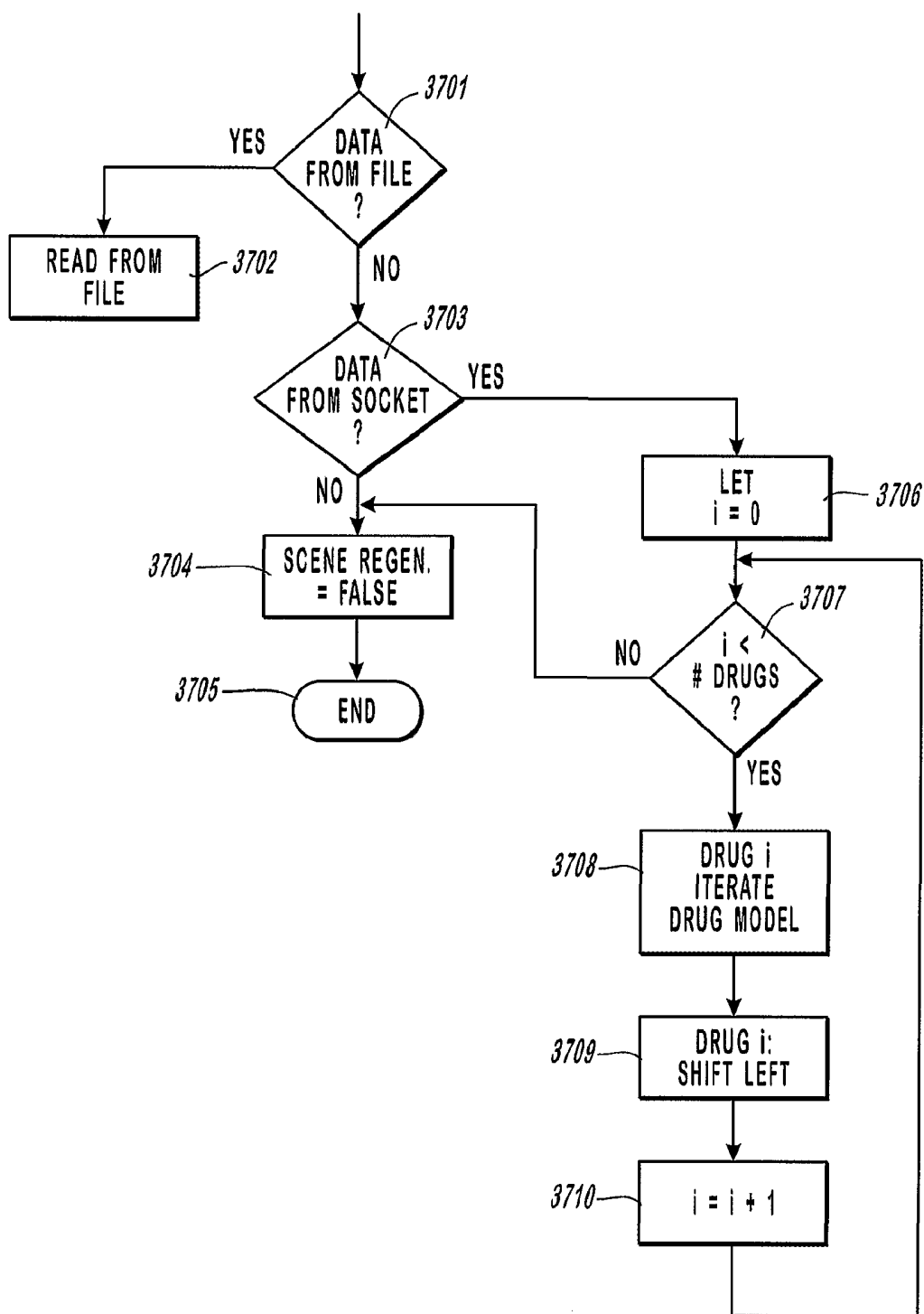

FIGURE 37

**METHOD AND APPARATUS FOR MONITORING  
ANESTHESIA DRUG DOSAGES,  
CONCENTRATIONS, AND EFFECTS USING  
N-DIMENSIONAL REPRESENTATIONS OF  
CRITICAL FUNCTIONS**

**BACKGROUND OF THE INVENTION**

**[0001]** 1. Field of the Invention

**[0002]** This invention relates to the visualization, perception, representation and computation of data relating to the attributes or conditions constituting the health state of a dynamic system. More specifically, this invention relates to the display and computation of anesthesia drug data, in which variables constituting attributes and conditions of a dynamic anesthesia system can be interrelated and visually correlated in time as three-dimensional objects.

**[0003]** 2. Description of the Related Art

**[0004]** A variety of methods and systems for the visualization of data have been proposed. Traditionally, these methods and systems fail to present in a real-time multi-dimensional format that is directed to facilitating a user's analysis of multiple variables and the relationships between such multiple variables. Moreover, such prior methods and systems, tend not to be specifically directed to the monitoring of anesthesia or which is capable of estimating, predicting and displaying drug dosages, drug concentrations, and drug effects during anesthesia. Prior methods typically do not process and display data in real-time, rather they use databases or spatial organizations of historical data. Generally, they also simply plot existing information in two or three dimensions, but without using three-dimensional geometric objects to show the interrelations between data. Often previous systems and methods are limited to pie charts, lines or bars to represent the data. Also, many previous systems are limited to particular applications or types of data. The flexibility and adaptability of the user interface and control is typically very limited, and may not provide flexible coordinate systems and historical-trend monitors. Other systems, which have a flexible user interface, generally require substantial user expertise in order to collect and evaluate the data, including the pre-identification of data ranges and resolution. Another common limitation of previous systems and methods is that they provide only a single or predetermined viewpoint from which to observe the data. Typically, prior systems and methods do not provide data normalcy frameworks to aid in the interpretation of the data. Furthermore, most prior methods use "icons," shapes, lines, bars, or graphs. For general background material, the reader is directed to U.S. Pat. Nos. 4,671,953, 4,752,893, 4,772,882, 4,813,013, 4,814,755, 4,823,283, 4,885,173, 4,915,757, 4,926,868, 5,021,976, 5,121,469, 5,262,944, 5,317,321, 5,484,602, 5,485,850, 5,491,779, 5,588,104, 5,592,195, 5,596,694, 5,651,775, 5,680,590, 5,751,931, 5,768,552, 5,774,878, 5,796,398, 5,812,134, 5,830,150, 5,873,731, 5,875,108, 5,901,246, 5,923,330, 5,925,014, 5,957,860, and 6,042,548 each of which is hereby incorporated by reference in its entirety for the material disclosed therein.

**[0005]** As this disclosure employs a number of terms, which may be new to the reader, the reader is directed to the applicants' definitions section, which is provided at the beginning of the detailed description section.

**SUMMARY OF THE INVENTION**

**[0006]** It is desirable to provide a method, system, and apparatus, which facilitates the rapid and accurate analysis of complex and quickly changing anesthesia drug data. Moreover, it is desirable that such a system and method be capable of estimating, predicting and displaying drug dosages, drug concentrations and drug effects during anesthesia. It is desirable that such a system and method be capable of analyzing time based, real-time, and historical data and that it be able to graphically show the relationships between various data.

**[0007]** Research studies have indicated that the human mind is better able to analyze and use complex data when it is presented in a graphic, real world type representation, rather than when it is presented in textual or numeric formats. Research in thinking, imagination and learning has shown that visualization plays an intuitive and essential role in assisting a user associate, correlate, manipulate and use information. The more complex the relationship between information, the more critically important is the communication, including audio and visualization of the data. Modern human factors theory suggests that effective data representation requires the presentation of information in a manner that is consistent with the perceptual, cognitive, and response-based mental representations of the user. For example, the application of perceptual grouping (using color, similarity, connectedness, motion, sound etc.) can facilitate the presentation of information that should be grouped together. Conversely, a failure to use perceptual principles in the appropriate ways can lead to erroneous analysis of information.

**[0008]** The manner in which information is presented also affects the speed and accuracy of higher-level cognitive operations. For example, research on the "symbolic distance effect" suggests that there is a relationship between the nature of the cognitive decisions (for example, is the data increasing or decreasing in magnitude?) and the way the information is presented (for example, do the critical indices become larger or smaller, or does the sound volume or pitch rise or fall?). Additionally, "population stereotypes" suggest that there are ways to present information that are compatible with well-learned interactions with other systems (for example, an upwards movement indicates an increasing value, while a downwards movement indicates a decreasing value).

**[0009]** Where there is compatibility between the information presented to the user and the cognitive representations presented to the user, performance is often more rapid, accurate, and consistent. Therefore, it is desirable that information be presented to the user in a manner that improves the user's ability to process the information and minimizes any mental transformations that must be applied to the data.

**[0010]** Therefore, it is the general object of this invention to provide a method and systems for presenting a three-dimensional visual and/or possibly an audio display technique that assists in the monitoring and evaluation of drug data.

**[0011]** It is a further object of this invention to provide a method and system that assists in the evaluation of drug data with respect to the classification of an anesthetic.

[0012] It is another object of this invention to provide a method and system that assists in the evaluation of drug data with respect to anesthetics, including sedatives, analgesics, and muscle relaxants.

[0013] It is a still further object of this invention to provide a method and system that assists in the display of drug effects during anesthesia that takes into account the patient's age, gender, height and weight as related to historical or normative values.

[0014] Another object of this invention is to provide a method and system that assists in the evaluation of drug effects during anesthesia that provides for system execution faster than real time.

[0015] A still further object of this invention is to provide a method and system, which provides the gathering and use of sensor measured data, as well as the formatting and normalization of the data in a format suitable to the processing methodology.

[0016] A further object of this invention is to provide a method and system, which can normalize drug concentration and can display the concentration relative to the time that it was administered.

[0017] Another object of this invention is to provide a method and system, which provides a three-dimensional graphic display for the use of doctors in an operating room.

[0018] It is another object of this invention to provide a method and system, which provides three-dimensional graphic display that is used in conjunction with automatic drug delivery systems.

[0019] It is an object of this invention to provide a method and system that provides a visual display record of the drugs administered and a current, past and predicted estimate of how the drug should be expected to affect the patient.

[0020] It is a further object of this invention to provide a method and system that permits an integrated and overall holistic understanding of the effects of drugs during anesthesia.

[0021] A further object of this invention is to provide a method and system where three-dimensional objects are built from three-dimensional object primitives, including: cubes, spheres, pyramids, n-polygon prisms, cylinders, slabs.

[0022] A still further object of this invention is to provide a method and system, wherein three-dimensional objects are placed within health-space based on the coordinates of their geometric centers, edges, vertices, or other definite geometric variables.

[0023] It is a further object of this invention to provide a method and system, which has three-dimensional objects that have three spatial dimensions, as well as geometric, aesthetic and aural attributes, to permit the mapping of multiple data functions.

[0024] It is another object of this invention to provide a method and system, which shows increases and decreases in data values using changes in location, size, form, texture, opacity, color, sound and the relationships thereof in their context.

[0025] It is a still further object of this invention to provide a method and system, wherein the particular three-dimensional configuration of three-dimensional objects can be associated with a particular time and health state.

[0026] A still further object of this invention is to provide a method and system that permits the simultaneous display of the history of data objects.

[0027] Another object of this invention is to provide a method and system that provides for the selection of various user selectable viewports.

[0028] It is a further object of this invention to provide a method and system that provides both a global and a local three-dimensional coordinate space.

[0029] It is another object of this invention to provide a method and system that permits the use of time as one of the coordinates.

[0030] It is a still further object of this invention to provide a method and system that provides a reference framework of normative values for direct comparison with the measured data.

[0031] It is a further object of this invention to provide a method and system where normative values are based on the average historical behavior of a wide population of healthy systems similar to the system whose health is being monitored.

[0032] A further object of this invention is to provide a method and system that provides viewpoints that can be selected to be perspective views, immersive Virtual Reality views, or any orthographic views.

[0033] Another object of this invention is to provide a method and system that permits the display of a layout of multiple time-space viewpoints.

[0034] A still further object of this invention is to provide a method and system that provides for zooming in and out of a time and/or space coordinate.

[0035] It is another object of this invention to provide a method and system that permits temporal and three-dimensional modeling of data "health" states based on either pre-recorded data or real-time data, that is as the data is obtained.

[0036] Another object of this invention is to provide a method and system that presents the data in familiar shapes, colors, and locations to enhance the usability of the data.

[0037] A still further object of the invention is to provide a method and system that uses animation, and sound to enhance the usefulness of the data to the user.

[0038] It is an object of this invention to provide a method and system for the measurement, computation, display and user interaction, of complex data sets that can be communicated and processed at various locations physically remote from each other, over a communication network, as necessary for the efficient utilization of the data and which can be dynamically changed or relocated as necessary.

[0039] It is a still further object of this invention to provide a method and system for the display of data that provides both a standard and a customized interface mode, thereby providing user and application flexibility.

[0040] These and other objects of this invention are achieved by the method and system herein described and are readily apparent to those of ordinary skill in the art upon careful review of the following drawings, detailed description and claims.

#### BRIEF DESCRIPTION OF THE DRAWINGS

[0041] In order to show the manner that the above recited and other advantages and objects of the invention are obtained, a more particular description of the preferred embodiment of the invention, which is illustrated in the appended drawings, is described as follows. The reader should understand that the drawings depict only a preferred embodiment of the invention, and are not to be considered as limiting in scope. A brief description of the drawings is as follows:

[0042] FIG. 1a is a top-level representative diagram showing the data processing paths of the preferred embodiment of this invention.

[0043] FIG. 1b is a top-level block diagram of the data processing flow of the preferred embodiment of this invention.

[0044] FIG. 1c is a top-level block diagram of one preferred processing path of this invention.

[0045] FIG. 1d is a top-level block diagram of a second preferred processing path of this invention.

[0046] FIGS. 2a, 2b, 2c, and 2d are representative 3-D objects representing critical functions.

[0047] FIG. 3 is a representation of data objects in H-space.

[0048] FIGS. 4a and 4b are representative views of changes in data objects in time.

[0049] FIGS. 5a, 5b, 5c, 5d, 5e, 5f, 5g and 5h are representative views of properties of data objects provided in the preferred embodiment of this invention.

[0050] FIG. 6 shows a 3-D configuration of the objects in H-space in the preferred embodiment of the invention.

[0051] FIG. 7 shows H-space with a time coordinate along with local-space coordinates.

[0052] FIGS. 8a and 8b show the global level coordinate system of the preferred embodiment of this invention.

[0053] FIGS. 9a and 9b show various viewpoints of the data within H-space in the preferred embodiment of this invention.

[0054] FIG. 10 shows the transformation of an object in space in context, with a reference framework, in the preferred embodiment of this invention.

[0055] FIG. 11a shows the zooming out function in the invention.

[0056] FIG. 11b shows the zooming in function in the invention.

[0057] FIGS. 12a and 12b show a 3-D referential framework of normative values.

[0058] FIG. 13 shows the interface modes of the preferred embodiment of this invention.

[0059] FIG. 14 is a hardware system flow diagram showing various hardware components of the preferred embodiments of the invention.

[0060] FIG. 15 is a software flow chart showing the logic steps of a preferred embodiment of the invention.

[0061] FIG. 16 is a software block diagram showing the logic steps of the image computation and rendering process of a preferred embodiment of the invention.

[0062] FIG. 17 is a photograph of the 3-dimensional display of a preferred embodiment of the invention.

[0063] FIG. 18 is a close-up front view of the cardiac object and the associated reference grid of a preferred embodiment of the invention.

[0064] FIG. 19 is a view of the front view portion of the display of a preferred embodiment of the present invention showing the cardiac object in the foreground and the respiratory object in the background.

[0065] FIG. 20 is a view of the top view portion of the display of a preferred embodiment of the present invention showing the cardiac object toward the bottom of the view and the respiratory object toward the top of the view.

[0066] FIG. 21 is a view of the side view portion of the display of a preferred embodiment of the present invention showing the cardiac object to the left and the respiratory object to the right.

[0067] FIG. 22 is a view of the 3-D perspective view portion of the display of a preferred embodiment of the invention showing the cardiac object in the left foreground and the respiratory object in the right background.

[0068] FIG. 23 is a view of an example of the preferred display of the drug effects shown in this invention.

[0069] FIG. 24 is a view of a second example of the preferred display of the drug effects shown in this invention.

[0070] FIG. 25 is a system flow process flow diagram of the preferred embodiment of this invention.

[0071] FIG. 26 is a preferred hardware/communication diagram of the preferred embodiment of this invention.

[0072] FIG. 27 is a top-level flow chart of the preferred drug monitoring process of this invention.

[0073] FIG. 28 is a detailed flow chart of the initialize variables section of the preferred drug monitoring process of this invention.

[0074] FIG. 29 is a detailed flow chart of the run drug display section of the preferred drug monitoring process of this invention.

[0075] FIG. 30 is a detailed flow chart of the run demo mode section of the preferred drug monitoring process of this invention.

[0076] FIG. 31 is a detailed flow chart of the idle loop section of the preferred drug monitoring process of this invention.

[0077] FIG. 32 is a detailed flow chart of the render the scene section of the preferred drug monitoring process of this invention.

[0078] FIG. 33 is a detailed flow chart of the iterate drug model section of the preferred drug monitoring process of this invention.

[0079] FIG. 34 is a detailed flow chart of the shift data left section of the preferred drug monitoring process of this invention.

[0080] FIG. 35 is a detailed flow chart of the decode data packet section of the preferred drug monitoring process of this invention.

[0081] FIG. 36 is a detailed flow chart of the draw plot section of the preferred drug monitoring process of this invention.

[0082] FIG. 37 is a detailed flow chart of the timer interrupt routine section of the preferred drug monitoring process of this invention.

[0083] Reference is now made in detail to the present preferred embodiments of the invention, examples of which are illustrated in the accompanying drawings.

#### DETAILED DESCRIPTION OF THE INVENTION

[0084] This invention is a method, system and apparatus for the visual display of complex sets of dynamic data. In particular, this invention provides the means for efficiently analyzing, comparing and contrasting data, originating from either natural or artificial systems. This invention provides n-dimensional visual representations of data through innovative use of orthogonal views, form, space, frameworks, color, shading, texture, transparency, sound and visual positioning of the data. The preferred system of this invention includes one or a plurality of networked computer processing and display systems, which provide real-time as well as historical data, and which processes and formats the data into an audio-visual format with a visual combination of objects and models with which the user can interact to enhance the usefulness of the processed data. While this invention is applicable to a wide variety of data analysis applications, one important application is the analysis of health data. For this reason, the example of a medical application for this invention is used throughout this description. The use of this example is not intended to limit the scope of this invention to medical data analysis applications only, rather it is provided to give a context to the wide range of potential application for this invention.

[0085] This invention requires its own lexicon. For the purposes of this patent description and claims, the inventors intend that the following terms be understood to have the following definitions.

[0086] An "artificial system" is an entity, process, combination of human designed parts, and/or environment that is created, designed or constructed by human intention. Examples of artificial systems include manmade real or virtual processes, computer systems, electrical power systems, utility and construction systems, chemical processes and designed combinations, economic processes (including, financial transactions), agricultural processes, machines, and human designed organic entities.

[0087] A "natural system" is a functioning entity whose origin, processes and structures were not manmade or arti-

ficially created. Examples of natural systems are living organisms, ecological systems and various Earth environments.

[0088] The "health" of a system is the state of being of the system as defined by its freedom from disease, ailment, failure or inefficiency. A diseased or ill state is a detrimental departure from normal functional conditions, as defined by the nature or specifications of the particular system (using historical and normative statistical values). The health of a functioning system refers to the soundness, wholeness, efficiency or well being of the entity. Moreover, the health of a system is determined by its functioning.

[0089] "Functions" are behaviors or operations that an entity performs. Functional fitness is measured by the interaction among a set of "vital-signs" normally taken or measured using methods well known in the art, from a system to establish the system's health state, typically at regular or defined time intervals.

[0090] "Health-space" or "H-space" is the data representation environment that is used to map the data in three or more dimensions.

[0091] "H-state" is a particular 3-D configuration or composition that the various 3-D objects take in H-space at a particular time. In other words, H-state is a 3-D snapshot of the system's health at one point of time.

[0092] "Life-space" or "L-space" provides the present and past health states of a system in a historical and comparative view of the evolution of the system in time. This 3-D representation environment constitutes the historical or Life-space of a dynamic system. L-space allows for both continuous and categorical displays of temporal dependent complex data. In other words, L-space represents the health history or trajectory of the system in time.

[0093] "Real-Time Representation" is the display of a representation of the data within a fraction of a second from the time when the event of the measured data occurred in the dynamic system.

[0094] "Real-Time User Interface" is the seemingly instantaneous response in the representation due to user interactivity (such as rotation and zooming).

[0095] A "variable" is a time dependent information unit (one unit per time increment) related to sensing a given and constant feature of the dynamic system.

[0096] "Vital signs" are key indicators that measure the system's critical functions or physiology.

[0097] In the preferred embodiments of this invention, data is gathered using methods or processes well known in the art or as appropriate and necessary. For example, in general, physiologic data, such as heart rate, respiration rate and volume, blood pressure, and the like, is collected using the various sensors that measure the functions of the natural system. Sensor-measured data is electronically transferred and translated into a digital data format to permit use by the invention. This invention uses the received measured data to deliver real-time and/or historical representations of the data and/or recorded data for later replay. Moreover, this invention permits the monitoring of the health of a dynamic system in a distributed environment. By distributed environment, it is meant that a user or users interacting with the

monitoring system may be in separate locations from the location of the dynamic system being monitored. In its most basic elements, the monitoring system of this invention has three major logical components: (1) the sensors that measure the data of the system; (2) the networked computational information systems that computes the representation and that exchanges data with the sensors and the user interface; and (3) the interactive user interface that displays the desired representation and that interactively accepts the users' inputs. The components and devices that perform the three major functions of this invention may be multiple, may be in the same or different physical locations, and/or may be assigned to a specific process or shared by multiple processes.

[0098] FIG. 1a is a top-level representative diagram showing the data processing paths of the preferred embodiment of this invention operating on a natural system. The natural system 101a is shown as a dynamic entity whose origin, processes and structures (although not necessarily its maintenance) were not manmade or artificially created. Examples of natural systems are living organisms, ecological systems, and various Earth environments. In one preferred embodiment of the invention, a human being is the natural system whose physiology is being monitored. Attached to the natural system 101a are a number of sensors 102. These sensors 102 collect the physiologic data, thereby measuring the selected critical functions of the natural system. Typically, the data gathering of the sensors 102 is accomplished with methods or techniques well known in the art. The sensors 102 are typically and preferably electrically connected to a digital data formatter 103. However, in other embodiments of this invention, the sensors may be connected using alternative means including but not limited to optical, RF and the like. In many instances, this digital data formatter 103 is a high-speed analog to digital converter. Also, connected to the digital data formatter 103 is the simulator 101b. The simulator 101b is an apparatus or process designed to simulate the physiologic process underlying the life of the natural system 101a. A simulator 101b is provided to generate vital sign data in place of a natural system 101a, for such purposes as education, research, system test, and calibration. The output of the digital data formatter 103 is Real-Time data 104. Real-Time data 104 may vary based on the natural system 101a being monitored or the simulator 101b being used and can be selected to follow any desired time frame, for example time frames ranging from one-second periodic intervals, for the refreshment rates of patients in surgery, to monthly statistics reporting in an ecological system. The Real-Time data 104 is provided to a data recorder 105, which provides the means for recording data for later review and analysis, and to a data modeling processor and process 108. In the preferred embodiments of this invention the data recorder 105 uses processor controlled digital memory, and the data modeling processor and process 108 is one or more digital computer devices, each having a processor, memory, display, input and output devices and a network connection. The data recorder 105 provides the recorded data to a speed controller 106, which permits the user to speed-up or slow-down, the replay of recorded information. Scalar manipulations of the time (speed) in the context of the 3-D modeling of the dynamic recorded digital data allows for new and improved methods or reviewing the health of the systems 101a,b. A customize/standardize function 107 is provided to permit the data

modeling to be constructed and viewed in a wide variety of ways according to the user's needs or intentions. Customization 107 includes the ability to modify spatial scale, such modifying includes but is not limited to zooming, translating, and rotating, attributes and viewports in addition to speed. In one preferred embodiment of the invention, the range of customization 107 permitted for monitoring natural systems 101a physiologic states is reduced and is heavily standardized in order to ensure that data is presented in a common format that leads to common interpretations among a diverse set of users. The data modeling processor and process 108 uses the prescribed design parameters, the standardized/customize function and the received data to build a three-dimensional (3-D) model in real-time and to deliver it to an attached display. The attached display of the as data modeling processor and process 108 presents a representation 109 of 3-D objects in 3-D space in time to provide the visual representation of the health of the natural system 101a in time, or as in the described instances of the simulated 101b system.

[0099] FIG. 1b is a top-level block diagram of the data processing flow of the preferred embodiment of this invention operating on an artificial system. An artificial system is a dynamic entity whose origin, processes and structure have been designed and constructed by human intention. Examples of artificial systems are manmade real or virtual, mechanical, electrical, chemical and/or organic entities. The artificial system 110a is shown attached to a number of sensors 111. These sensors 111 collect the various desired data, thereby measuring the selected critical functions of the artificial system. Typically, the data gathering of the sensors 111 is accomplished with methods or techniques well known in the art. The sensors 111 are connected to a data formatter 112, although alternative connection means including optical, RF and the like may be substituted without departing from the concept of this invention. In many instances, this digital data formatter 112 is a high-speed analog to digital converter. Although, in certain applications of the invention, namely stock market transactions, the data is communicated initially by people making trades. Also connected to the digital data formatter 112 is the simulator 110b. The simulator 110b is an apparatus or process designed to simulate the process underlying the state of the artificial system 110a. The simulator 110b is provided to generate vital data in place of the artificial system 110a, for such purposes as education, research, system test, and calibration. The output of the digital data formatter 112 is Real-Time data 113. Real-Time data 113 may vary based on the artificial system 110a being monitored or the simulator 110b being used and can be selected to follow any desired time frame, for example time frames ranging from microsecond periodic intervals, for the analysis of electronic systems, to daily statistics reported in an financial trading system. The Real-Time data 113 is provided to a data recorder 114, which provides the means for recording data for later review and analysis, and to a data modeling processor and process 117. In the preferred embodiments of this invention the data recorder 114 uses processor controlled digital memory, and the data modeling processor and process 117 is one or more digital computer devices, each having a processor, memory, display, input and output devices and a network connection. The data recorder 114 provides the recorded data to a speed controller 115, which permits the user to speed-up or slow-down, the replay of recorded information. Scalar manipulations of the time

(speed) in the context of the 3-D modeling of the dynamic recorded digital data allows for new and improved methods or reviewing the health of the system **110a,b**. A customize/standardize function **116** is provided to permit the data modeling to be constructed and viewed in a wide variety of ways according to the user's needs or intentions. Customization **116** includes the ability to modify spatial scale (such modification including, but not limited to translating, rotating, and zooming), attributes, other structural and symbolic parameters, and viewports in addition to speed. The range of customization form monitoring artificial systems' **110a,b** states is wide and not as standardized as that used in the preferred embodiment of the natural system **101a,b** monitoring. In this Free Customization, the symbolic system and display method is fully adaptable to the user's needs and interests. Although this invention has a default visualization space, its rules, parameters, structure, time intervals, and overall design are completely customizable. This interface mode customize/standardize function **116** also allows the user to select what information to view and how to display the data. This interface mode customization **116** may, in some preferred embodiments, produce personalized displays that although they may be incomprehensible to other users, facilitate highly individual or competitive pursuits not limited to standardized interpretations, and therefore permit a user to look at data in a new manner. Such applications as analysis of stock market data or corporation health monitoring may be well suited to the flexibility of this interface mode. The data modeling processor and process **117** uses the prescribed design parameters, the customize/standardized function **116** and the received real-time data **113** to build a three-dimensional (3-D) model in time and to deliver it to a display. The display of the data modeling processor and process **117** presents a representation **118** of 3-D objects in 3-D space in time to provide the visual representation of the health of the artificial system **110a** in time, or as in the described instances of the simulated **110b** system.

[0100] FIG. 1c is a top-level block diagram of one preferred processing path of this invention. Sensors **119** collect the desired signals and transfer them as electrical impulses to the appropriate data creation apparatus **120**. The data creation apparatus **120** converts the received electrical impulses into digital data. A data formatter **121** receives the digital data from the data creation apparatus **120** to provide appropriate formatted data for the data recorder **122**. The data recorder **122** provides digital storage of data for processing and display. A data processor **123** receives the output from the data recorder **122**. The data processor **123** includes a data organizer **124** for formatting the received data for further processing. The data modeler **125** receives the data from the data organizer and prepares the models for representing to the user. The computed models are received by the data representer **126**, which formats the models for presentation on a computer display device. Receiving the formatted data from the data processor **123** is a number of data communication devices **127, 130**. These devices **127, 130** include a central processing unit, which controls the image provided to one or more local displays **128, 131**. The local displays may be interfaced with a custom interface module **129** which provides user control of such attributes as speed **131**, object attributes **132**, viewports **133**, zoom **134** and other like user controls **135**.

[0101] FIG. 1d is a top-level block diagram of a second preferred processing path of this invention. In this embodi-

ment of the invention a plurality of entities **136a,b,c** are attached to sensors **137a,b,c** which communicate sensor data to a data collection mechanism **138**, which receives and organizes the sensed data. The data collection mechanism **138** is connected **139** to the data normalize and formatting process **140**. The data normalize and formatting process **140** passes the normalized and formatted data **141** to the distributed processors **142**. Typically and preferably the processing **142** is distributed over the Internet, although alternative communication networks may be substituted without departing from the concept of this invention. Each processing unit **142** is connected to any of the display devices **143a,b,c** and receives command control from a user from a number of interface units **144a,b,c**, each of which may also be connected directly to a display devices **143a,b,c**. The interface units **144a,b,c** receive commands **145** from the user that provide speed, zoom and other visual attributes controls to the displays **143a,b,c**.

[0102] FIGS. 2a, 2b, 2c, and 2d are representative 3-D objects representing critical functions. Each 3-D object is provided as a symbol for a critical function of the entity whose health is being monitored. The symbol is created by selecting the interdependent variables that measure a particular physiologic function and expressing the variable in spatial (x,y,z) and other dimensions. Each 3-D object is built from 3-D object primitives (i.e., a cube, a sphere, a pyramid, a n-polygon prism, a cylinder, a slab, etc.). More specifically, the spatial dimensions (extensions X, Y and Z) are modeled after the most important physiologic variables based on (1) data interdependency relationships, (2) rate, type and magnitude of change in data flow, (3) geometric nature and perceptual potential of the 3-D object, for example a pyramid versus a cylinder, (4) potential of the object's volume to be a data-variable itself by modeling appropriate data into x, y and z dimensions (e.g., in one preferred application of the invention, cardiac output is the result of heart rate (x and y dimensions) and stroke volume (z)), (5) orthographic viewing potential (see viewport) and (6) the relationship with the normal values framework.

[0103] The first representative object **201**, shown in FIG. 2a, is an engine process. The object **201** representing this process is provided on a standard x-y-z coordinate axis **202**. The correlation between temperature, shown in the x1-dimension **204**, engine RPM, shown in the y1-dimension **205** and exhaust gas volume, shown in the z1-dimension **203** is shown by changes in the overall sizes and proportion of the object **201**. In the shown example object **201** the engine gas volume **203** is large, when RPM **205** is low and the engine temperature **204** is in the middle range. This combination of values, even without specific identified values suggests an engine's starting point.

[0104] The second representative object **206**, shown in FIG. 2b, is an object representing cardiac function using stroke volume, in the y2-dimension **209**, and the heart rate per second, shown as the x2, z2 dimensions. The total cardiac volume is shown as the total spherical volume **208**.

[0105] The third representative object **211**, shown in FIG. 2c, represents the interaction between the number of contracts, shown in the y3-dimension **212**, the average revenue per contract, shown in the z3-dimension **214**, and the average time per contract, shown in the x3-dimension **213**. Assessing the interaction among these variables is important in monitoring of a sales department's operations.

[0106] The fourth representative object **215** is shown in FIG. **2d**, shows the respiratory function generated by the respiratory rate, shown in x4-dimension **216**, the respiratory volume, shown in the y4-dimension **216**, and inhalation/exhalations, shown in the z4-dimension **218**.

[0107] FIG. **3** is a representation of data objects in H-space **301**. Data sets are represented as 3-D objects of various characteristics and relationships within a 3-D representation space. The data representation environment in this figure is used to map the physiologic data in 3-D and is what is referred to as "Health-space" or "H-space"**301**. The 3-D objects are placed within H-space on the 3 coordinates of their geometric centers. The coordinates for an object's geometric center depends on the relevant data associated to the particular critical function the object represents. For example, in the preferred embodiment, the cardiac function object, shown as a spherical object **302**, is placed in H-space **301** based on Mean Blood Pressure, designated as Oy **306** and Oxygen Saturation in the Blood, shown as Oz **307**. In the other example object, the prism **309** is placed in H-space **301** depending on sales profit, shown as Py **312**, and products in stock, shown as Pz, **311**. The location of 3-D objects in H-space **301** allows for the overall extension envelope of H-space, the relationship between 3-D objects and spaces within H-space **301**, the viewport display areas and the departure from normative values. Typically and preferably the centers of the objects **302**, **309** are located in the middle of the x-dimension of H-space **301**.

[0108] FIGS. **4a** and **4b** are representative views of changes in data objects in time. In FIG. **4a**, the x-coordinate **400** is used to measure the temporal dimension of an objects **402** trajectory. The y-z plane **401a** determines the location of an object's geometric center within H-space. Increases or decreases in data values associated with the coordinates of the object's geometric center that make that object's location change in time as shown in path line **401b**. In this view, the object **402** is presented in four different time intervals **403**, **404**, **405**, **406**, thereby creating a historical trajectory. The time intervals at which the object **402** is shown are provided **407**. In FIG. **4b**, increases in size and proportion are presented, **408**, **409**, **410**, **411** providing an example of changes in values. The monitoring of these changes in time assists the user establish and evaluate comparative relationships within and across H-states.

[0109] FIGS. **5a**, **5b**, **5c**, **5d**, **5e**, **5f**, **5g** and **5h** are representative views of properties of data objects provided in the preferred embodiment of this invention. In addition to the three x-y-z spatial dimensions used for value correlation and analysis, 3-D objects may present data value states by using other geometric, aesthetic, and aural attributes that provide for the mapping of more physiologic data. These figures show some of the representative other geometric, aesthetic, and aural attributes supported for data presentation in this invention. FIG. **5a** shows changes in apparent volumetric density. A solid object **501** is shown in relation to a void object **502** and an intermediate state **503** object. FIG. **5b** shows changes in apparent 3-D enclosure. An open object **504**, a closed object **505**, and an intermediate state **506** is shown. FIG. **5c** shows the apparent degree of formal deformation. A normal object **507**, a distorted object **508**, a transformed object **509**, and a destroyed object **510** are shown in comparison. FIG. **5d** shows secondary forms of the objects. "Needles"**513** protruding through a standard object

**512** in combination **511** is shown in comparison with a boundary **515** surrounding a standard object **514** and a bar **517** protruding into the original form object **518** forming a new combination object **516** are shown providing additional combination supported in this invention. FIG. **5e** shows the various degrees of opacity of the object's surface, showing an opaque object **519**, a transparent object **520** and an intermediate state object **521**. FIG. **5f** shows the various degrees of texture supported by the object display of this invention, including a textured object **522**, a smooth object **523** and an intermediate textured object **524**. FIG. **5g** is intended to represent various color hue possibilities supported for objects in this invention. An object with color hue is represented **525** next to a value hue object **526** and a saturation hue object **527** for relative comparison. Naturally, in the actual display of this invention colors are used rather than simply the representation of color shown in FIG. **5g**. FIG. **5h** shows the atmospheric density of the representation space possible in the display of objects in this invention. An empty-clear space **528**, a full-dark space **530** and an intermediate foggy space **523** are shown with 3-D objects shown within the representative space **529**, **531**, **533**.

[0110] Aural properties supported in this invention include, but are not limited to pitch, timbre, tone and the like.

[0111] FIG. **6** shows the 3-D configuration of the objects in H-space in the preferred embodiment of the invention. In this view the local level, H-space **601** is shown within which the 3-D objects **602**, **603**, and **604** are located. Object **602** represents the respiratory function of an individual. Its **602** x-y-z dimensions change based on the parameter-based dimensional correlation. The object **603** represents the efficiency of the cardiac system by varying the x,y,z coordinates of the object. The object **604** represents a human brain function, also with the x,y,z dimensions changing based on the parameter-based dimensional correlation. In this way the user can easily view the relative relationships between the three physiological objects **602**, **603**, **604**. Within H-space **601**, the temporal coordinate (i.e., periodic time interval for data capturing that defines how H-space is plotted in Live-space—see FIG. **7**) is a spatial dimension on which data is mapped. The x-dimension of **605** of the H-space **601** can be mapped to another independent variable such as heart rate period, blood pressure or the like. The location of an object in the y-dimension **606** of H-space **601** can be mapped to additional variables that are desired to be monitored such as SaO2 content, CaO2 content, or temperature in the blood. The location of an object in the z-dimension **607** of the H-space **601** can also be mapped to additional variables that the user desires to monitor. A hypothetical object **608** shows that the three coordinates are contextual to a particular object **608** and need not be the same for all objects, except in the object's **608** extension measuring properties. Fixed x- and z-dimension values **609a** and **609b** are shown as constant. The y-value **610** of this object **608** changes to fluctuating values or data type that results in the height of the object **608** increasing or decreasing. This view shows another object **611** showing the relationship between the three dimensions. Constant x- and y-values **612a** and **612b** are shown. The z-value **613** of this object **611** changes to fluctuating values or data types that result in the width of the object **611** increasing or decreasing. An overlapping view **614** of an object **615** that has extended past the H-space limitation. A limit of H-space **616** with a spherical object

**617** located inside H-space **616** shown with the degree of extension shown in shaded circles.

[0112] FIG. 7 shows a series of H-spaces **701**, **702**, **703**, **704**, **705**, **706** along a global time coordinate **708**, and the local-space coordinates **707** that governs each H-space. Each of these H-spaces represents progressive states of the dynamic system at pre-established temporal intervals ( $T_0$ ,  $T_{-1}$ ,  $T_{-2}$ , . . .  $T_{-n}$ ) and the six **701**, **702**, **703**, **704**, **705**, **706** together show the evolution of that system over time, demonstrating the historical representation of individual H-states within an overall "Life-space" or "L-space." At the global level (or L-space), one of the coordinates, typically x, is always time. The temporal coordinate is scaled based on the intervals at which a particular functions system's physiologic data are collected by the art or as appropriate. This interval or module is fixed and constant across L-space and provides the necessary temporal frame of reference for comparing different H-spaces. The fixed temporal interval also determines the maximum x-extension of the representation envelope of H-space. The other two coordinates, y and z, provide L-space with extension and are not fixed. The three coordinates thus described provide a regulating 3-D environment within which the H-states can be visualized and related to each other.

[0113] FIGS. **8a** and **8b** show the global level coordinate system of the preferred embodiment of this invention. FIG. **8a** shows the L-space coordinate system **801** in its preferred embodiment. The x-dimension **802** of L-space is mapped to a constant time interval, set by means standard in the art or otherwise as appropriate. The present position of H-state is also indicated on the x-dimension **802**. The y-dimension **803** in both positive and negative extensions is measured, up and down from the x-axis. This dimension **803** can be mapped to a data variable within particular 3D object in space. The z-dimension **804** is shown in both positive and negative extensions measured forwards and backwards from the intersecting x-axis. This dimension **804** can be mapped to a data variable within a particular 3D object in space. Now for FIG. **8b** a prismatic object **800** represents a critical function, whose evolution is being monitored in L-space, of a given dynamic system. The front view **805** shows the different H-states of the prism/function **800** using a time T to T-n historical trend. The level of intersection and separation between the front views of the prism indicate abnormal health states of the critical function the object **800** represents. No separation or intersection shows normal function conditions. The trajectory in the y-dimension of the prism (i.e., H-states of the critical function) are mapped to a variable that cause their relative position to change in the + and -y dimension. The current state **806** of the prism is shown in this front view **805**. A top view of **809** of the three-dimensional L-space is shown, showing the evolution of the prism **800** backward in time and showing a T to T-N historical trend. The level of intersection and separation indicate abnormal health states of the particular critical function the prism represents. No separation or intersection shows normal conditions. The trajectory in the z-dimension of the object is mapped to a variable that causes their position to change in the + and -z dimension. This top view shows both the z and y trajectories in one comprehensive view. The perspective view **808** of L-space gives a comprehensive view of the interaction of the prisms (the H-states of the function) and their movement in all dimensions. The side

view **807** of L-space shows the prisms and their positions in L-space giving a simultaneous view of z and y trajectories.

[0114] FIGS. **9a** and **9b** shows various viewpoints in which the data may be visualized in the preferred embodiment of this invention. This figure shows representations of a data object (a prism) and is provided to show that there are two basic types of viewports: orthographic and perspectival. The orthographic viewports **906**, **907**, **908**, of FIG. **9b** use a parallel system of projection to generate representations of H-space that maintains dimensional constancy without deformation. Some examples of orthographic views include traditional architectural or engineering views of objects, such as a top view, a front view, and a side view. The orthographic viewport allows for accurate and focused 2-D expressions of the actual 3-D object. The perspectival viewport **909**, shown in FIG. **9b** uses a focal system of projection to generate depictions analogous to our perception of reality but at the cost of deformation and lack of dimensional constancy. For example, the top view **902** along with the side view **903** and the front view of **904** of the 3-D data object **901** are shown in FIG. **9a**. FIG. **9b** shows three orthogonal views **906**, **907**, **908** along with a perspective view **909** of the current data object. The number and types of viewports used in a particular embodiment of the invention may range from one type, for example a perspective viewport allowing immerse virtual reality, to combinations of both types. In the preferred current embodiment, there are the four viewports shown in FIG. **9b**. Given the 3-D nature of data objects and H-space, viewports provide the user with different depictions of the same data.

[0115] FIG. **10** shows the transform of an object in space in context, with a reference framework, in the preferred embodiment of this invention. The referential framework **1010** is typically set based on population normals or patient normals. This framework assists the user to see deviations from normal very quickly. An individual spherical object **1011** that represents cardiac function is shown located in L-space and in relation to the referential framework. A side view **1012** is shown along with several cardiac objects. In this view the referential framework provides a center target point so that a user can make the necessary corrections to bring the object back to the ideal center of the framework. A perspectival view **1013** of the framework is also shown along with several cardiac objects. The top view **1014** of the framework is shown with several spherical objects (representing cardiac states). This figure demonstrates the variety of viewports provided to the user by this invention, which provides enhanced flexibility of analysis of the displayed data.

[0116] FIG. **11a** shows the zooming out function in the invention. This invention provides a variety of data display functions. This figure shows the way views may be zoomed in and out providing the relative expansion or compression of the time coordinate. Zooming out **1101** permits the user to look at the evolution of the system's health as it implies the relative diminution of H-states and the expansion of L-space. This view **1101** shows a zoomed out view of the front view showing a historical view of many health states. A side view **1102** zoomed out view is provided to show the historical trend stacking up behind the current view. A 3-D perspectival, zoomed out view **1103** showing the interaction

of H-states over a significant amount of time is provided. A zoomed out top view **1104** shows the interaction of H-states over a large amount of time.

[**0117**] FIG. **11b** shows the zooming in function of the invention. The zooming in front view **1105** is shown providing an example of how zooming in permits a user to focus in on one or a few H-states to closely study specific data to determine with precision to the forces acting on a particular H-state. A zoomed in side view **1106** is provided showing the details of specific variables and their interactions. A zoomed in 3-D perspective view **1107** of a few objects is also shown. Also shown is a zoomed in top view **1108** showing the details of specific variables and their interaction.

[**0118**] FIG. **12a** shows a 3-D referential framework of normative values that is provided to permit the user a direct comparison between existing and normative health states, thereby allowing rapid detection of abnormal states. The reference framework **1201** works at both the global L-space level and the local H-space level. "Normal" values are established based on average historical behavior of a wide population of systems similar to the one whose health is being monitored. This normal value constitutes the initial or by-default ideal value, which, if necessary may be adjusted to acknowledge the particular characteristics of a specific system or to follow user-determined specifications. The highest normal value of vital sign "A" **1202 (+y)** is shown, along with the lowest normal value of "B" **1203 (-z)**, the lowest normal value of vital sign "A" **1204 (-y)** and the highest normal value of vital sign "B" **1205 (+z)**. In FIG. **12b**, abnormal values of "A" and "B" are shown in an orthogonal view. An abnormally high value of "A" **1206**, an abnormally low value of "B" **1207**, an abnormally low value of "A" **1208** and an abnormally high value of "B" **1209** are shown.

[**0119**] FIG. **13** shows a comparison of the interface modes of the preferred embodiment of this invention. This invention provides two basic types of interface modes: (a) standardized or constrained customization; and (b) free or total customization. Each is directed toward different types of applications. The standardized or constrained customization **1301** uses a method and apparatus for user interface that is set a-priori by the designer and allows little customization. This interface mode establishes a stable, common, and standard symbolic system and displaying method that is "user-resistant". The fundamental rules, parameters, structure, time intervals, and overall design of L-space and H-space are not customizable. Such a normalized symbolic organization creates a common interpretative ground upon which different users may arrive at similar conclusions when provided common or similar health conditions. This is provided because similar data flows will generate similar visualization patterns within a standardized symbolic system. This interface method is intended for social disciplines, such as medicine in which common and agreeable interpretations of the data are highly sought after to ensure appropriate and verifiable monitoring, diagnosis and treatment of health states. The customization permitted in this mode is minimal and is never threatening to render the monitoring device incomprehensible to other users.

[**0120**] The free or total customization interface mode **1302** provides a symbolic system and displaying method

that is changeable according to the user's individual needs and interests. Although the invention comes with a default symbolic L-space and H-space, its rules, parameters, structure, time intervals, and overall design are customizable. This interface mode also permits the user to select what information the user wishes to view as well as how the user wishes to display it. This interface mode may produce personalized displays that are incomprehensible to other users, but provides flexibility that is highly desired in individual or competitive pursuits that do not require agreeable or verifiable interpretations. Examples of appropriate applications may include the stock market and corporate health data monitoring.

[**0121**] FIG. **14** is a hardware system flow diagram showing various hardware components of the preferred embodiments of the invention in a "natural system" medical application. Initially a decision **1401** is made as to the option of using data monitored on a "real" system, that is a real patient, or data from the simulator, for anesthesiology training purposes. If the data is from a real patient, then the patient **1402** is provided with patient sensors **1404**, which are used to collect physiological data. Various types of sensors, including but not limited to non-invasive BP sensors, ECG leads, SaO<sub>2</sub> sensors and the like may be used. Digital sensors **1416** may also provide physiological data. An A/D converter **1405**, is provided in the interface box, which receives the analog sensor signals and outputs digital data to a traditional patient monitor **1406**. If the data is produced **1401** by the simulator **1403**, a control box and mannequins are used. The control box controls the scenarios simulated and the setup values of each physiological variable. The mannequins generate the physiological data that simulates real patient data and doctors collect the data through different, but comparable sensors. The traditional patient monitor **1406** displays the physiological data from the interface box on the screen. Typically and preferably, this monitor **1406** is the monitor used generally in an ICU. A test **1407** is made to determine the option of where the computations and user interface are made, that is whether they are made on the network server **1408** or otherwise. If a network server **1408** is used, all or part of the data collection and computation may be performed on this computer server **1408**. An option **1409** is provided for running a real time representation versus a representation delayed or replayed from events that previously occurred. For real time operation, a data buffer **1410** is provided to cache the data so that the representation is played in real time. For the replay of previous events, a data file **1411** provides the means for permanently storing the data so that visualization is replayed. The visualization software **1412** runs on a personal computer and can display on its monitor or on remote displays via the internet or other networking mechanism. Typically the physiological data measured on either a real patient or the simulator are fed to the personal computer from the traditional data monitor. A standard interface such as RS232, the internet, or via a server, which receives data from the monitor, may serve as the communication channel to the personal computer running the visualization software **1412**. This program **1412** is the heart of the invention. The program **1412** computes the representation and processes the user interface. An option **1413** is provided for computing and user interface on the local desktop personal computer or for distribution across the internet or other network mechanism. If a local desktop personal computer is selected, the

personal computer **1414** with an adequate display for computation of the visualization and user interface is provided. If a remote user interface **1415** is selected the display and user interface is communicated across the internet.

[0122] FIG. 15 is a software flow chart showing the logic steps of a preferred embodiment of the invention. The preferred embodiment of this invention begins by reading the startup file **1501**, which contains the name of the window and the properties associated with the invention. The properties associated with the a window include formulas to set object properties, text that is to be rendered in the scene, the initial size of the window, the initial rotation in each window, zoom, lighting and patient data that describes the normal state of each variable. Internal data tables are next initialized **1502**. For each new window encountered in the startup file a new window object is made and this window object is appended to the list of windows. The window object contains an uninitialized list of properties describing the state of the window, which is filled with data from the startup file. The event loop is entered **1503**. This is a window system dependent infinite loop from which the program does not exit. After some initialization, the program waits for user input and then acts on this input. The program then takes control of the event loop for continuous rendering that is if there is no interactivity in the program. Initialization **1504** of windows is next performed. This involves calls to the window system dependent functions (these are functions that are usually different on different computational platforms) that creates the windows and displays them on the computer screen. In the current preferred embodiment of the invention, OpenGL is required, although alternative embodiments using other 3D application programming interfaces, such as PEX or DirectX, could be substituted without departing from the concept of this invention. Also, in the preferred embodiment of this invention, a personal computer graphics card is preferred in the personal computer so as to permit smooth animation with multiple windows. Although the lack of such a card is not absolutely required for operation of this invention. New data is received **1509**, typically from the data file **1506** or the data buffer **1507**. This new data **1509** can come from any source that generates floating-point numbers. The preferred line of data is composed of columns of floating point numbers separated by space. At this point the current time is also stored so that the next line of data can be obtained at the next user defined time interval, which is typically set at about 1 second. Object properties are next computed **1510**. This is performed by using formulas that are specified in the startup file to compute properties of objects. Data fields in the formulas are specified by writing the column number preceded by a dollar sign. For example,  $\$1/20.0$  would divide the first field by 20.0. The specific properties in this application are: cardiac object dimensions, material properties, and position. Material properties can include the red, green, and blue components as they appear under ambient, diffuse, and specular light, as well as transparency. The cardiac object position includes the y and z positions as well as an x shift. If four or more lines of data have been acquired, the respiratory object properties are computed. A delay is necessary because a cubic spline is fitted, using four data points to do the fit, to the data points to generate a smooth respiratory object. Therefore, until four time steps have passed, the curtain is not rendered. Thereafter, it is rendered every time new data is acquired. Cardiac object properties include material prop-

erties and the height of the color bands. Blood pressure object length and materials are the thin cylinders that go through the top and bottom of each ellipsoid. Next, reference grid properties are computed. All objects, except the cardiac object reference are stationary, in the current implementation. The cardiac object reference can move according to the movement of the cardiac object if the user specifies this movement in the startup file. Next, sounds are computed **1511** and made audible **1513**. Objects and reference grids are rendered **1512**. Before rotation the newest object appears at the right side of the screen and oldest object is at the left side of the screen. Sound is produced **1513** next. A test **1514** is next made to determine if smooth animation is selected. If smooth animation is selected the scene will scroll during the time the program is waiting to get new data. The program, using available computing resources, selects the minimum time increment so that the shift of the objects can be rendered within the increment, but limiting the increment to the smallest increment that human eyes can detect. If smooth animation is not selected, objects are shifted to the left **1515** such that the distance from the center of the newest cardiac object to that of the former cardiac object is equal to the inter-cardiac spacing. The process waits **1508** until the current time minus the time since data was last obtained equals the data acquisition period specified by the user. If the current time minus the time when the data was last acquired equals the user specified data acquisition period then a new line of data is acquired. If smooth animation is selected, then the cardiac objects are shifted to the left by computing **1516** to that when it is time to get the next line of data, the cardiac objects have moved **1517**, **1518** such that the distance from the rightmost cardiac object to the position where the new cardiac object will appear is equal to the inter-cardiac-object distance. For example, if it takes 0.20 seconds to render the previous scene, the period of data acquisition is 1.0 seconds, and the x shift of the rightmost cardiac object is 0.1 units then the program will shift the scene left  $(0.20/(1.0+0.20))*(1.0-0.1)=0.15$ . The formula in the denominator is  $(1.0+0.20)$  instead of 0.8 because, if the scene has been shifted left such that, when new data is acquired, the shifting has stopped (because the position of the cardiac objects satisfies the criteria that the distance from the center of the rightmost cardiac object to the center point where the new cardiac object will be rendered=1 unit) then the animation will no longer be smooth, that is, when new data is acquired the animation will appear to stop. Note, that the respiratory object is never entirely smoothly shifted because no data is available to render the object at the intermediate time steps.

[0123] FIG. 16 is a software block diagram showing the logic steps of the image computation and rendering process of a preferred embodiment of the invention. This process begins with acquiring the window identification **1601** of the current rendering context. Next, the data structure is found **1602** corresponding to the current window identification. After which, the view is set **1603**. A rotation matrix is set **1604**. A projection matrix is set **1605**. Lights are set **1606**. The back buffer is cleared **1607**. Object processing **1608** begins, and includes for each cardiac object, calling OpenGL to see material properties; shift left one inter-cardiac-object distance; push the modelview matrix, shift x,y, and z directions; call OpenGL utility toolkit to render the cardiac object; set the top cardiac object material properties, call OpenGL quadrics function to render top cardiac object; set top cardiac object material properties, call OpenGL quadrics

function to render bottom cardiac object and pop modelview matrix. Next, the view is set **1609**, as above. The respiratory object is rendered **1610**, by setting OpenGL to render quad strips, for each polygon strip set material properties, and send vertex to OpenGL. Reference grids are rendered **1611** by setting material property of the cardiac reference grid. The current position is set **1612** to be the ideal position of the newest cardiac object, that is the position corresponding to a patient in ideal health. The cardiac object material properties are set **1613**. The OpenGL utility toolkit is called to render **1614** the cardiac object. Next, OpenGL is set to render quads **1615**. After which the material properties of the reference planes are set **1616**. Vertices that compose the reference planes through the OpenGL pipeline are sent **1617** and buffers are swapped **1618**. Buffer swap is a window system defendant function.

[**0124**] FIG. **17** is a photograph of the 3-dimensional display of a preferred embodiment of the invention. The 3-D view shown at lower right **1706** provides a comprehensive, integrated and interactive view of all physiological data, and shows the interaction between the different objects in relation to the reference frame. This view can be manipulated by the user to fit specific application needs. The front **1701**, side **1704**, **1705** and top views **1702** show how the same data appears from different vantage points. In this figure these views **1701**, **1702**, **1704**, **1705** show the interaction between the cardiac object, the reference frame and the respiratory object, with the side view **1704** providing a target for optimum efficiency of the cardiac system **1705** shows the level of gas concentration in the lungs and overall tidal volume in the respiratory system. This FIG. **17** is a representation of a true 3-D model of the physiologic data. The circle **1703** shown is the top view of the respiratory waveform showing CO<sub>2</sub> content in the lungs and inspiration and expiration values. In **1703**, a real time display, the object grows and shrinks with each heartbeat. Its height is proportional to the heart's volume output and its width is proportional to heart rate. The gridframe (or reference framework) shows the expected normal values for stroke volume and heart rate. The position of this object in the vertical direction of the display is proportional to the patient's mean blood pressure. This graphic objects shape and animation provides a useful graphical similarity to a working heart. In the preferred embodiment, the background is colored to show inspired and expired gases. The height of the "curtain" is proportional to tidal volume, while the width is proportional to respiratory rate. The colors, which are, displayed in the preferred display show the concentrations of respiratory gases. Time is set to move from right to left, with the present or current conditions shown at the "front" or right edge of each view. Past states remain to provide a historical view of the data.

[**0125**] FIG. **18** is a close-up front view of the cardiac object and the associated reference framework of a preferred embodiment of the invention. The upper limit of normal blood pressure value is shown **1800** on the reference frame. The systolic blood pressure level is indicated by the bar **1801** penetrating the cardiac sphere **1806**. The height **1802** of the sphere **1806** is proportional to cardiac output, which shows the optimum efficiency of the heart. The width of the sphere **1806** is proportional to 1/heart rate. The elevation of the sphere **1806** is an indication of mean blood pressure, where the center reference gridline is a normal mean blood pressure **1803**. The lower limit, or diastolic blood pressure **1804**

is shown by the length of the bar extending downward from the sphere **1806**. Previous historical values for the sphere **1806** are also provided in **1805**, **1807**.

[**0126**] FIG. **19** is a view of the front view portion of the display of a preferred embodiment of the present invention showing the cardiac object in the foreground and the respiratory object in the background. This view **1900** provides a more quantitative image of the hemodynamic variables, stroke volume, blood pressure **1901** and heart rate. The "normal" reference lines are more apparent. In the preferred embodiment, respiration is shown by changes in the background color.

[**0127**] FIG. **20** is a view of the top view portion of the display **2000** of a preferred embodiment of the present invention showing the cardiac object toward the bottom of the view and the respiratory object toward the top of the view. Inhaled gas **2002** and exhaled gas **2003**. CO<sub>2</sub> concentrations and oxygen saturation of the arterial blood **2001** versus time are also shown.

[**0128**] FIG. **21** is a view of the side view portion of the display of a preferred embodiment of the present invention showing the cardiac object to the left and the respiratory object to the right. Gas concentration in the lungs **2101**, a calibrated scale for gas concentration **2103**, blood pressure **2100**, and oxygen saturation **2101** are shown. The end view, shown here in FIG. **21**, is especially useful during treatment, where the goal is to bring the variables back to the center or normal state. Functional relationships can be added to this view to predict how treatment can be expected to bring the variables back to normal.

[**0129**] FIG. **22** is a view of the 3-D perspective view portion of the display of a preferred embodiment of the present invention showing the cardiac object in the left foreground and the respiratory object in the right background. This view **2200** provides a comprehensive, integrated and interactive view of nine physiological variables. The sphere **2201** grows and shrinks with each heartbeat. Its height is proportional to the heart's stroke volume and its width is proportional to heart rate. This graphic object **2201** offers useful similarity to a beating heart. The gridframe **2202** shows the expected normal values for stroke volume and heart rate. The position of this object **2201** on the screen is proportional to the patient's mean blood pressure. The ends of the bar **2203** drawn vertically through the center of the heart object show systolic and diastolic blood pressure. In the preferred embodiment of the invention, the background **2204** is colored to show inspired and expired gases. The height of the "curtain" **2205** is proportional to tidal volume. The width of each fold **2206** is proportional to respiratory rate. In the preferred embodiment colors are used to show the concentrations of respiratory gases. Time moves from right to left with the present condition shown at the "front" or right edge of the view **2200**. Past states **2207** remain to permit a historical view of the data.

[**0130**] FIG. **23** is a view of an example of the preferred display **2300** of the drug effects shown in this invention. Concentration is shown by the plots **2301a,b,c**. The concentration is also presented with respect to the classification of the anesthetic, sedatives **2302**, analgesic **2303**, and muscle relaxants **2304**. In the preferred embodiment each drug is color-coded. Past, current and predicted concentrations are normalized with respect to the drug's EC<sub>95</sub> value (the drug

concentration at which 95% of the population is completely affected by the anesthetic drug) and plotted relative to the time **2305** that it was administered. The current drug effects are represented as a 3-dimensional bar or pie charts **2302**, **2303**, **2304**. The effects are presented proportionally to the extent that the objects **2302**, **2303**, **2304** are filled.

[0131] FIG. **24** is a view of a second example of the preferred display **2400** of the drug effects shown in this invention. The plots **2401a,b,c** are shown displaying effect site drug concentration. The pie chart **2402** shows the sedation effect. The bar chart **2403** shows the analgesia effect. The bar chart **2404** shows the muscle relaxant effect. This data is plotted against time **2405**.

[0132] FIG. **25** is a system flow process flow diagram of the preferred embodiment of this invention. A drug delivery system **2500** communicates through a data stream **2502** to a drug display monitor device **2503**. The patient **2504** is shown receiving anesthetic drugs **2505** from a drug delivery system **2506**. The preferred drug delivery system **2506** includes an infusion pump **2507**, an anesthesia machine **2508** and/or a set of bar coded syringes and a bar code reader. A simulator program or process **2501** is provided for testing purposes and is designed to simulate boles (injection) drugs **2511**, infusion drugs **2512**, and anesthetic agents **2513**. The drug delivery system **2506** communicates with the data stream **2502** via multiple data channels **2510**. In the present preferred embodiment of the invention, the multiple data channels may include a TCP/IP socket, a serial RS-232 interface, and/or a serial RS-495 USB interface. Other alternative communication channels can be substituted without departing from the concept of this invention. The preferred interface **2514** between the simulator **2501** and the data stream **2502** is a UDP socket, although alternative communication interfaces can be substituted without departing from the concept of this invention. The data stream **2502** provides a data path **2515** to the drug display monitor system **2503**. Included in the drug display monitor system is a decode data function **2516** that receives the data stream **2502**. A dosage or infusion rate calculator **2517** receives the decoded data. A drug modeler/normalizer **2518** receives the dosage and/or infusion rate data and proceeds to store **2519** the dosage type, dosage rate, drug concentration, drug type, the concentration effect, and the site concentration effect. The drug modeler/normalizer **2518** provides the appropriate data to a first display function **2520** for showing drug dosage or rate and drug name, to a second display function **2521** for showing past, present, and predicted site concentration effects, and to a third display effect computer function **2522**.

[0133] FIG. **26** is a preferred hardware/communication diagram of the preferred embodiment of this invention. A central processing unit (CPU or processor) **2601** is provided to execute the process of this invention, specifically to produce the internal representation of the drug display, to decode the data stream, and to compute the interaction between drug models. The processor **2601** communicates with the data stream **2502** via a communication channel **2602**. The communication channel **2602** can be a serial, parallel or socket type channel. The processor **2601** is electrically connected to volatile memory **2603** for the dynamic storage of variables. The processor **2601** is also electrically connected to a static memory device (such as static RAM, disk drives or the like) **2604** for the storage of drug delivery data and trends. A user interface **2607** is

connected to the processor **2601** to enable user interaction. The typical user interface **2607** is a keyboard, mouse, touchscreen or the like. A graphics adapter **2608** is in communication with the processor **2601** for preparing data for rendering on a standard display **2609**. The typical standard display **2609** is a monitor, an LCD device or the like. A hardcopy printer **2605** and a data dump visualization device **2606** is also provided, typically in communication with the processor **2601** through the memory **2604**.

[0134] FIG. **27** is a top-level flow chart of the preferred drug monitoring process of this invention. Initially, the system is powered up **2701**. Variables are initialized **2702**. Additional detail on the variable initialization **2702** is provided in FIG. **28**. Polling **2703** for data collection is performed **2703**. A test **2704** is made to determine if a connection has been detected. If no connection is detected the process returns to the polling **2703** for data connection. If a connection is detected, a test **2705** is made to determine if a UDP socket connection exists. If no UDP socket connection exists, then a test **2706** is made to determine if a file connection has been made. If no file connection has been made, polling **2703** for data connection continues. If a file connection has been made, then a demo mode is run **2707**. Additional detail on the demo mode is described with respect to FIG. **30**. If a UDP socket connection exists, then the socket header is decoded **2708**. A test **2709** is then made to determine if the socket has been initialized. If the socket has not been initialized, the process continues polling **2703** for data connection. If the socket has been initialized **2709**, then initialization data is stored **2710**. This initialization data includes, but may not be limited to, patient height, weight, gender, age, model iteration time or update rate and the like. After storing **2710** the data, the drug display function is run **2711** or executed. Additional detail on the run drug display step **2711** is provided below with respect to FIG. **29**.

[0135] FIG. **28** is a detailed flow chart of the initialize variables section **2702** of the preferred drug monitoring process of this invention. Initially, the number of drugs is set **2901** to zero. The drug object pointer array is initialized **2802** to NULL. The scene rendered flag is set **2803** to false. The user window is setup **2804** for OpenGL. Next, a sedative plot, analgesia plot and a neuro-muscular block plot is created **2805**. A test **2806** is then made to determine if the processes is idle, if so the IdleLoop service routine is called. Additional detail on the IdleLoop service routine is discussed below and shown in FIG. **31**.

[0136] FIG. **29** is a detailed flow chart of the run drug display section **2711** of the preferred drug monitoring process of this invention. First, a timer is started **2901**. This enables the timer interrupt routine to be called at intervals of "update time." Additional detail on the timer interrupt is provided below in association with FIG. **37**. Next, the data source is polled **2902**. A test **2903** is made to determine if a data packet header byte has been found. If not, the polling **2902** continues. If a data packet header byte is found, the data packet is decoded **2904** and the scene render flag is set **2905** to false. Additional detail on the data decoder step **2904** is provided below with respect to FIG. **35**.

[0137] FIG. **30** is a detailed flow chart of the run demo mode section **2707** of the preferred drug monitoring process of this invention. The file is opened **3001**. The first character ("C") is read **3002**. A test **3003** is made to determine if

C="\*". If C="\*" then the file is read and assigned **3004** a sample period. Following the reading and assignment **3004** this section ends **3013**. If C is not equal to "\*", then a test **3005** is made to determine if C="#". If C="#", then a new drug record is created **3006**, the new drug information is decoded **3007**, and the new drug is added **3008** to the appropriate drug plot, after which this section of the process ends **3013**. If C is not equal to "#", then a test **3009** is made to determine if C="\". If C="\", then the drug concentration is read **3010**, the drug concentration is assigned **3011**, and the concentration is added **3012** to the drug queue, after which this section ends **3013**. If C is not equal to "\", this section of the process ends **3013**.

[0138] FIG. 31 is a detailed flow chart of the idle loop section, of FIG. 28 step **2806**, of the preferred drug monitoring process of this invention. First, I is set **3101** to zero. A test **3102** is made to determine if I is less than the number of drugs. If I is not less than the number of drugs, then a test **3103** is made to determine if the scene has been rendered. If the scene has been rendered, this section of the process ends **3105**. If the scene has not been rendered, then the scene is rendered **3104**. Additional detail on the scene-rendering step **3104**, is discussed below, with respect to FIG. 32. If I is less than the number of drugs, then the drug value I is iterated **3106** for the predictive model. Additional detail on the predictive model **3106** process is discussed below with respect to FIG. 33. After the predictive model is iterated **3106**, I is incremented **3107** by one, and the process returns to the test **3102**.

[0139] FIG. 32 is a detailed flow chart of the render the scene section **3104** of the preferred drug monitoring process of this invention. First, chart titles are drawn **3201**. Next, the sedation plot is drawn **3202**. The analgesia plot is then drawn **3203**. After which the neuro muscular block plot is drawn **3204**. Additional detail on the plotting **32012**, **3203**, **3204** is discussed below with respect to FIG. 36. The OpenGL buffers are finally swapped **3206**, after which this section of the process ends **3206**.

[0140] FIG. 33 is a detailed flow chart of the iterate drug model section **3106** of the preferred drug monitoring process of this invention. First the reference to the specific PKModel of the drug is captured **3301**. Next, the PKModel is iterated **3302**. The preferred PkModel interaction uses an algorithm described in Shafer and Greg, *Algorithms to Rapidly Achieve and Maintain Stable Drug Concentrations at the Site of Drug Effect with a Computer Controlled Infusion Pump*, Journal of Pharmokinetics and Biopharmaceutics, vol. 20, #2, 1992. After iteration of the PkModel, the resulting concentration is added **3303** to the drug's circular queue of data, thereby including either past, present or predicted circular queues. Then this section of process ends **3304**.

[0141] FIG. 34 is a detailed flow chart of shift data left section of the preferred drug monitoring process of this invention. Initially, a test **3401** is made to determine if the drug queue is full. If the drug queue is full, then an item is removed **3402** from the front of the queue. Then a test **3403** is made to determine if the drug queue of predicted concentrations exists. If the predicted queue doesn't exist, then this section of the process ends **3407**. If the predicted queue exists, then a test **3404** is made to determine if the queue is not empty. If the queue is empty, then this section of the process ends **3407**. If the queue is not empty, then an item

is removed **3405** from the front of the queue. The GL data current is set **3406** to false and this section of the process ends **3407**.

[0142] FIG. 35 is a detailed flow chart of the decode data packet section **2904** of the preferred drug monitoring process of this invention. The data is received **3501** from a socket. A test **3502** is made to determine if it is a header packet. If it is a header packet, then a test **3503** is made to determine if the packet length header is okay. If the packet length header is not okay, then the process of this section ends **3519**. If the packet length header is okay, then the sample period is decoded **3504**, the weight is decoded **3504**, the height is decoded, and the gender is decoded **3506**, after which this section of the process ends **3519**. If it is not a header packet, then a test **3507** is made to determine if it is a message packet. If it is a message packet, then the message is decoded **3508** and the message is logged **3509** to a file. If it is not a message packet, then a test **3510** is made to determine if it is a data packet. If it is not a data packet, then this section of the process ends **3519**. If it is a data packet, then drug data is decoded **3511**. A test **3512** is made to determine if this is a new drug. If it is a new drug, a new drug record is created **3513**, and the drug is added **3514** to the appropriate plot and the process continues to the decoding **3515** of the drug volume. If it is not a new drug, the drug volume is decoded **3515**. Next, the drug concentration is decoded **3516**, the infusion rate is decoded **3517** and the future concentration is predicted **3518**, after which this section of the process ends **3519**.

[0143] FIG. 36 is a detailed flow chart of the draw plot sections **3202**, **3203**, **3204** of the preferred drug monitoring process of this invention. Initially, a shaded gradient is drawn **3601**. The axes are drawn **3602**. The EC95 wire is drawn **3603**. Ticks are drawn **3604**. Plot labels are drawn **3605**. Drug labels are drawn **3606**. Effect data is retrieved **3607**, including concentration and dosage data for each drug in the plot. Dosages are drawn **3608**. Concentric curves are drawn **3609**. Effect data is retrieved **3610**, as a percentage of effect. Effect object outlines are drawn **3611**. Filled effect objects are drawn **3612**, proportionally to the drug effect. The Object label effects are drawn **3613**.

[0144] FIG. 37 is a detailed flow chart of the timer interrupt routine section, see FIG. 29 step **2901**, of the preferred drug monitoring process of this invention. A test **3701** is made to determine if the data is from a file. If it is from a file, the data is read from the file, as shown in FIG. 30 from step **3002** on. If the data is not from a file, a test **3703** is made to determine if the data is from a socket. If the data is not from a socket, then the scene rendered flag is set **3704** to false, and this section of the process ends **3705**. If the data is from a socket, then I is set to zero. Next, a test **3707** is made to determine if I is less than the number of drugs. If I is not less than the number of drugs, then the process goes to step **3704**. If I is less than the number of drugs, then the drug I is iterated **3708**, as shown in FIG. 33, to generate the past and present concentrations. Next, the drug I is shifted left **3709**, as shown in FIG. 34. I is incremented **3710** by one and the iteration process continues with test **3707**.

[0145] It is to be understood that the above-described embodiments and examples are merely illustrative of numerous and varied other embodiments and applications which

may constitute applications of the principles of the invention. These above-described embodiments are provided to teach the present best mode of the invention only, and should not be interpreted to limit the scope of the claims. Such other embodiments, may use somewhat different steps and routines which may be readily devised by those skilled in the art without departing from the spirit or scope of this invention and it is our intent that they are deemed to be within the scope of this invention.

1-14. (canceled)

15. A system for visually displaying pharmacokinetic and pharmacodynamic effects as a function of time, comprising:

a drug delivery system configured to digitally record a plurality of drug delivery information data corresponding to at least drug type, initial drug dosage, and drug delivery method onto a data channel;

a data stream device in data communication with the drug delivery device, wherein the data communication includes transmission of the data channel;

a drug display monitor in data communication with the data stream device, wherein the data communication with the data stream device includes transmission of the data channel, and wherein the drug display monitor further includes:

a data decoder and a dosage calculator;

a drug modeler and normalizer configured to correlate the data channel with data corresponding to average pharmacokinetic effects to dynamically calculate a current concentration value representing the current drug concentration and a plurality of predicted values corresponding to a period of future time, and wherein the current concentration value is mathematically correlated with data corresponding to average pharmacodynamic effects to dynamically calculate a plurality of current effect values representing analgesic, anesthetic, and muscle relaxation;

a data storage device configured to digitally record the current concentration value, the plurality of current effect values, and the plurality of predicted concentration values; and

a display generator configured to visually display a drug concentration as a function of time including a visually discrete representation of a past, present, and predicted drug concentration, wherein the past and present drug concentration are visual representations of the current concentration value as a function of time and the predicted drug concentration is a visual representation of the plurality of predicted concentration values, and wherein the display generator is configured to visually display the current pharmacodynamic effects, wherein the current pharmacodynamic effects are visual representations of the plurality of effect values.

16. The system of claim 15, wherein the drug delivery system comprises at least one of an infusion pump, a gas administration machine, and one or more bolus injection apparatus.

17. The system of claim 15, wherein the drug delivery system further comprises a simulator, which simulates the present and future concentrations based on a model.

18. The system of claim 17, wherein the simulator simulates bolus drugs.

19. The system of claim 15, wherein the simulator simulates infusion drugs.

20. The system of claim 15, wherein the drug modeler and normalizer are configured to calculate corresponding current drug concentration values and current effect values for multiple injected drug types.

21. The system of claim 15, wherein the visual display of the drug concentration as a function of time includes a real time display, wherein the real time display includes a pharmacokinetic display and a pharmacodynamic display.

22. The system of claim 21, wherein the pharmacokinetic display includes a graph of a particular drugs concentration including visual representations of a drug input time, a drug type, a total drug dosage, a drug delivery method, a plurality of past time concentration values, a current concentration value, and a plurality of predicted concentration values.

23. The system of claim 22, wherein the pharmacokinetic display further includes an EC95 value at which 95% percent of the population is completely affected by the anesthetic drug.

24. The system of claim 21, wherein the display includes a plurality of pharmacokinetic displays representing independent drugs currently affecting the system.

25. The system of claim 21, wherein the pharmacodynamic display includes a sedation display, an analgesia display, and a muscle relaxation display, and wherein each of the displays visually illustrates a current state of the system as a function of total pharmacodynamic effect.

26. A system for visually displaying pharmacokinetic and pharmacodynamic effects as a function of time, comprising:

a processing element programmed to record a plurality of drug delivery information data corresponding to at least drug type, initial drug dosage, and drug delivery method onto a data channel, wherein the processing element is further programmed to correlate the data channel with data corresponding to average pharmacokinetic effects to dynamically calculate a current concentration value representing the current drug concentration and a plurality of predicted values corresponding to a period of future time, and wherein the current concentration value is mathematically correlated with data corresponding to average pharmacodynamic effects to dynamically calculate a plurality of current effect values representing analgesic, anesthetic, and muscle relaxation; and

an output element configured to visually display the drug concentration as a function of time including a visually discrete representation of a past, present, and predicted drug concentration, wherein the past and present drug concentration are visual representations of the current concentration value as a function of time and the predicted drug concentration is a visual representation of the plurality of predicted concentration values, and wherein the display generator is configured to visually display the current pharmacodynamic effects, wherein the current pharmacodynamic effects are visual representations of the plurality of effect values.

27. The system of claim 26, wherein the visual display of the drug concentration as a function of time includes a real time display, wherein the real time display includes a pharmacokinetic display and a pharmacodynamic display.

**28.** The system of claim 27, wherein the pharmacokinetic display includes a graph of a particular drugs concentration including visual representations of a drug input time, a drug type, a total drug dosage, a drug delivery method, a plurality of past time concentration values, a current concentration value, and a plurality of predicted concentration values.

**29.** The system of claim 27, wherein the pharmacodynamic display includes a sedation display, an analgesia display, and a muscle relaxation display, and wherein each of the displays visually illustrates a current state of the system as a function of total pharmacodynamic effect.

**30.** A system for visually displaying pharmacokinetic and pharmacodynamic effects as a function of time, comprising:

a processing module programmed to record a plurality of drug delivery information data corresponding to at least drug type, initial drug dosage, and drug delivery method onto a data channel, wherein the processing element is further programmed to correlate the data channel with data corresponding to average pharmacokinetic effects to dynamically calculate a current concentration value representing the current drug concentration and a plurality of predicted values corresponding to a period of future time, and wherein the current concentration value is mathematically correlated with data corresponding to average pharmacodynamic effects to dynamically calculate a plurality of current effect values representing analgesic, anesthetic, and muscle relaxation; and

an output module configured to graphically display the drug concentration as a function of time including a

visually discrete representation of a past, present, and predicted drug concentration, wherein the past and present drug concentration are visual representations of the current concentration value as a function of time and the predicted drug concentration is a visual representation of the plurality of predicted concentration values, and wherein the display generator is configured to visually display the current pharmacodynamic effects, wherein the current pharmacodynamic effects are visual representations of the plurality of effect values.

**31.** The system of claim 30, wherein The system of claim 12, wherein the visual display of the drug concentration as a function of time includes a real time display, wherein the real time display includes a pharmacokinetic display and a pharmacodynamic display.

**32.** The system of claim 31, wherein the pharmacokinetic display includes a graph of a particular drugs concentration including visual representations of a drug input time, a drug type, a total drug dosage, a drug delivery method, a plurality of past time concentration values, a current concentration value, and a plurality of predicted concentration values.

**33.** The system of claim 31, wherein the pharmacodynamic display includes a sedation display, an analgesia display, and a muscle relaxation display, and wherein each of the displays visually illustrates a current state of the system as a function of total pharmacodynamic effect.

\* \* \* \* \*

专利名称(译)	使用关键功能的n维表示来监测麻醉药物剂量，浓度和效果的方法和装置		
公开(公告)号	<a href="#">US20080033661A1</a>	公开(公告)日	2008-02-07
申请号	US11/843524	申请日	2007-08-22
[标]申请(专利权)人(译)	SYROID NOAH WESTENSKOW DWAYNEĪ BERMUDEZ JULIOÇ 奥古特JAMES STRAYER DAVID大号 ALBERT ROBERTWĪ 福尔摩斯迈克尔·威廉姆森 FRANK DREWS PRENZEL HAUNKE		
申请(专利权)人(译)	SYROID NOAH WESTENSKOW DWAYNEĪ BERMUDEZ JULIOÇ 奥古特JAMES STRAYER DAVID大号 ALBERT ROBERTWĪ 福尔摩斯迈克尔·威廉姆森 FRANK DREWS PRENZEL HAUNKE		
当前申请(专利权)人(译)	SYROID NOAH WESTENSKOW DWAYNEĪ BERMUDEZ JULIOÇ 奥古特JAMES STRAYER DAVID大号 ALBERT ROBERTWĪ 福尔摩斯迈克尔·威廉姆森 FRANK DREWS PRENZEL HAUNKE		
[标]发明人	SYROID NOAH WESTENSKOW DWAYNE R BERMUDEZ JULIO C AGUTTER JAMES STRAYER DAVID LEE ALBERT ROBERT WILLIAM HOLMES MICHAEL E DREWS FRANK PRENZEL HAUNKE		
发明人	SYROID, NOAH WESTENSKOW, DWAYNE R. BERMUDEZ, JULIO C. AGUTTER, JAMES STRAYER, DAVID LEE ALBERT, ROBERT WILLIAM HOLMES, MICHAEL E. DREWS, FRANK PRENZEL, HAUNKE		

IPC分类号	G06F19/00 A61B5/00 A61M5/142 A61M16/00
CPC分类号	A61B5/00 A61M5/142 A61M16/00 A61M2202/048 G09B23/28 A61M2205/6072 G06F19/3437 G06F19/3456 A61M2205/3576 A61M16/021 G16H20/17 G16H50/50
外部链接	<a href="#">Espacenet</a> <a href="#">USPTO</a>

摘要(译)

公开了一种用于监视，诊断和评估动态系统状态的方法，系统和装置。该方法和系统提供处理装置，用于接收感测和/或模拟数据，将这些数据转换成可显示的对象格式，并以这样的方式显示这些对象，使得各个变量之间的相互关系可以由用户相关和识别。本发明提供了关于动态系统的关键功能的整体状态的快速认知掌握。系统提供显示的对象，这些对象实时变化以显示系统功能的变化。它是一种高度灵活的系统，适用于各种应用，包括生物系统，环境系统，工程系统，经济系统，机械系统，化学系统等。特别地，本发明涉及在监测或向患者施用药物的过程中处理和显示药物数据以供医生使用。

