



US009510758B2

(12) **United States Patent**  
**Warger, II et al.**

(10) **Patent No.:** **US 9,510,758 B2**  
(45) **Date of Patent:** **Dec. 6, 2016**

(54) **APPARATUS, SYSTEMS AND METHODS FOR MEASURING BLOOD PRESSURE WITHIN AT LEAST ONE VESSEL**

5/12; A61B 5/02007; A61B 5/407; A61B 3/14; A61B 5/202; A61B 5/02055; A61B 5/0066; A61B 5/14558; A61B 2576/00; G02B 6/4266; G01K 13/002

(75) Inventors: **William C. Warger, II**, Cambridge, MA (US); **Simon C. Schlachter**, Somerville, MA (US); **Joseph Gardecki**, Acton, MA (US); **Brett Eugene Bouma**, Quincy, MA (US); **Guillermo J. Tearney**, Cambridge, MA (US)

USPC ..... 600/407-480  
See application file for complete search history.

(73) Assignee: **THE GENERAL HOSPITAL CORPORATION**, Boston, MA (US)

(56) **References Cited**

U.S. PATENT DOCUMENTS

2,339,754 A 1/1944 Brace  
3,090,753 A 5/1963 Matuszak et al.

(Continued)

(\* ) Notice: Subject to any disclaimer, the term of this patent is extended or adjusted under 35 U.S.C. 154(b) by 280 days.

FOREIGN PATENT DOCUMENTS

CN 1550203 12/2004  
DE 4105221 9/1991

(Continued)

(21) Appl. No.: **13/283,143**

(22) Filed: **Oct. 27, 2011**

(65) **Prior Publication Data**

US 2012/0108956 A1 May 3, 2012

**Related U.S. Application Data**

(60) Provisional application No. 61/407,368, filed on Oct. 27, 2010.

(51) **Int. Cl.**  
**A61B 6/00** (2006.01)  
**A61B 5/021** (2006.01)

(Continued)

OTHER PUBLICATIONS

R. Haggitt et al., "Barrett's Esophagus Correlation Between Mucin Histochemistry, Flow Cytometry, and Histological Diagnosis for Predicting Increased Cancer Risk," Apr. 1988, American Journal of Pathology, vol. 131, No. 1, pp. 53-61.

(Continued)

*Primary Examiner* — Sanjay Cattungal

(74) *Attorney, Agent, or Firm* — Andrews Kurth Kenyon LLP

(52) **U.S. Cl.**  
CPC ..... **A61B 5/021** (2013.01); **A61B 3/14** (2013.01); **A61B 5/0066** (2013.01); **A61B 5/02007** (2013.01); **A61B 5/02055** (2013.01); **A61B 5/12** (2013.01); **A61B 5/14558** (2013.01); **A61B 5/202** (2013.01); **A61B 5/407** (2013.01); **A61B 5/4064** (2013.01); **A61B 5/42** (2013.01); **A61B 2576/00** (2013.01)

(57) **ABSTRACT**

Exemplary apparatus and method for obtaining information for at least one structure can be provided. For example, it is possible to forward at least one first electro-magnetic radiation to the at least one structure which is external from the apparatus. At least one second electro magnetic radiation provided from the at least one structure (which is based on the first electro-magnetic radiation(s)) can be detected. It is also possible to determine at least one characteristic of the structure(s) based on the second electro-magnetic radiation(s), and obtain data relating to a pressure of at least one portion of the structure(s) based on the characteristic(s).

(58) **Field of Classification Search**  
CPC ..... A61B 2562/0266; A61B 2562/0271; A61B 2562/0238; A61B 2576/02; A61B 5/021; A61B 5/4064; A61B 5/42; A61B

**26 Claims, 4 Drawing Sheets**

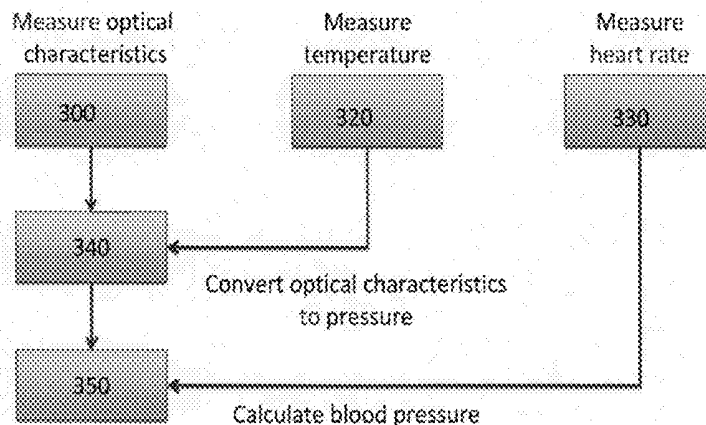

(51)	<b>Int. Cl.</b>		5,251,009 A	10/1993	Bruno
	<i>A61B 5/00</i>	(2006.01)	5,262,644 A	11/1993	Maguire
	<i>A61B 5/1455</i>	(2006.01)	5,275,594 A	1/1994	Baker
	<i>A61B 5/0205</i>	(2006.01)	5,281,811 A	1/1994	Lewis
	<i>A61B 3/14</i>	(2006.01)	5,283,795 A	2/1994	Fink
	<i>A61B 5/02</i>	(2006.01)	5,291,885 A	3/1994	Taniji et al.
	<i>A61B 5/12</i>	(2006.01)	5,293,872 A	3/1994	Alfano et al.
	<i>A61B 5/20</i>	(2006.01)	5,293,873 A	3/1994	Fang
			5,302,025 A	4/1994	Kleinerman
			5,304,173 A	4/1994	Kittrell et al.
			5,304,810 A	4/1994	Amos
(56)	<b>References Cited</b>		5,305,759 A	4/1994	Kaneko et al.
	U.S. PATENT DOCUMENTS		5,317,389 A	5/1994	Hochberg et al.
			5,318,024 A	6/1994	Kittrell et al.
			5,321,501 A	6/1994	Swanson et al.
			5,333,144 A	7/1994	Liedenbaum et al.
			5,348,003 A	9/1994	Caro
			5,353,790 A	10/1994	Jacques et al.
			5,383,467 A	1/1995	Auer et al.
			5,394,235 A	2/1995	Takeuchi et al.
			5,400,771 A	3/1995	Pirak et al.
			5,404,415 A	4/1995	Mori et al.
			5,411,016 A	5/1995	Kume et al.
			5,414,509 A	5/1995	Veligidan
			5,419,323 A	5/1995	Kittrell et al.
			5,424,827 A	6/1995	Horwitz et al.
			5,439,000 A	8/1995	Gunderson et al.
			5,441,053 A	8/1995	Lodder et al.
			5,450,203 A	9/1995	Penkethman
			5,454,807 A	10/1995	Lennox et al.
			5,459,325 A	10/1995	Hueton et al.
			5,459,570 A	10/1995	Swanson et al.
			5,465,147 A	11/1995	Swanson
			5,479,928 A	1/1996	Cathignol et al.
			5,486,701 A	1/1996	Norton et al.
			5,491,524 A	2/1996	Hellmuth et al.
			5,491,552 A	2/1996	Knuttel
			5,522,004 A	5/1996	Djupsjobacka et al.
			5,526,338 A	6/1996	Hasman et al.
			5,555,087 A	9/1996	Miyagawa et al.
			5,562,100 A	10/1996	Kittrell et al.
			5,565,983 A	10/1996	Barnard et al.
			5,565,986 A	10/1996	Knuttel
			5,566,267 A	10/1996	Neuberger
			5,583,342 A	12/1996	Ichie
			5,590,660 A	1/1997	MacAulay et al.
			5,600,486 A	2/1997	Gal et al.
			5,601,087 A	2/1997	Gunderson et al.
			5,621,830 A	4/1997	Lucey et al.
			5,623,336 A	4/1997	Raab et al.
			5,628,313 A	5/1997	Webster, Jr.
			5,635,830 A	6/1997	Itoh
			5,649,924 A	7/1997	Everett et al.
			5,697,373 A	12/1997	Richards-Kortum et al.
			5,698,397 A	12/1997	Zarling et al.
			5,701,155 A	12/1997	Wood et al.
			5,710,630 A	1/1998	Essenpreis et al.
			5,716,324 A	2/1998	Toida
			5,719,399 A	2/1998	Alfano et al.
			5,730,731 A	3/1998	Mollenauer et al.
			5,735,276 A	4/1998	Lemelson
			5,740,808 A	4/1998	Panescu et al.
			5,748,318 A	5/1998	Maris et al.
			5,748,598 A	5/1998	Swanson et al.
			5,752,518 A	5/1998	McGee et al.
			5,784,352 A	7/1998	Swanson et al.
			5,785,651 A	7/1998	Baker et al.
			5,795,295 A	8/1998	Hellmuth et al.
			5,801,826 A	9/1998	Williams
			5,801,831 A	9/1998	Sargoytchev et al.
			5,803,082 A	9/1998	Stapleton et al.
			5,807,261 A	9/1998	Benaron et al.
			5,810,719 A	9/1998	Toida
			5,817,144 A	10/1998	Gregory et al.
			5,829,439 A	11/1998	Yokosawa et al.
			5,836,877 A	11/1998	Zavislan et al.
			5,840,023 A	11/1998	Oraevsky et al.
			5,840,031 A	11/1998	Crowley
			5,840,075 A	11/1998	Mueller et al.

(56)

## References Cited

## U.S. PATENT DOCUMENTS

5,842,995	A	12/1998	Mahadevan-Jansen et al.	6,249,630	B1	6/2001	Stock et al.
5,843,000	A	12/1998	Nishioka et al.	6,263,234	B1	7/2001	Engelhardt et al.
5,843,052	A	12/1998	Benja-Athon	6,264,610	B1	7/2001	Zhu
5,847,827	A	12/1998	Fercher	6,272,268	B1	8/2001	Miller et al.
5,862,273	A	1/1999	Pelletier	6,272,376	B1	8/2001	Marcu et al.
5,865,754	A	2/1999	Sevick-Muraca et al.	6,274,871	B1	8/2001	Dukor et al.
5,867,268	A	2/1999	Gelikonov et al.	6,282,011	B1	8/2001	Tearney et al.
5,871,449	A	2/1999	Brown	6,297,018	B1	10/2001	French et al.
5,872,879	A	2/1999	Hamm	6,301,048	B1	10/2001	Cao et al.
5,877,856	A	3/1999	Fercher	6,308,092	B1	10/2001	Hoyns
5,887,009	A	3/1999	Mandella et al.	6,324,419	B1	11/2001	Guzelsu et al.
5,892,583	A	4/1999	Li	6,341,036	B1	1/2002	Tearney et al.
5,910,839	A	6/1999	Erskine et al.	6,353,693	B1	3/2002	Kano et al.
5,912,764	A	6/1999	Togino	6,359,692	B1	3/2002	Groot
5,920,373	A	7/1999	Bille	6,374,128	B1	4/2002	Toida et al.
5,920,390	A	7/1999	Farahi et al.	6,377,349	B1	4/2002	Fercher
5,921,926	A	7/1999	Rolland et al.	6,384,915	B1	5/2002	Everett et al.
5,926,592	A	7/1999	Harris	6,393,312	B1	5/2002	Hoyns
5,949,929	A	9/1999	Hamm	6,394,964	B1	5/2002	Sievert, Jr. et al.
5,951,482	A	9/1999	Winston et al.	6,396,941	B1	5/2002	Bacus et al.
5,955,737	A	9/1999	Hallidy et al.	6,421,164	B2	7/2002	Tearney et al.
5,956,355	A	9/1999	Swanson et al.	6,437,867	B2	8/2002	Zeylikovich et al.
5,968,064	A	10/1999	Selmon et al.	6,441,892	B2	8/2002	Xiao et al.
5,975,697	A	11/1999	Podoleanu et al.	6,441,959	B1	8/2002	Yang et al.
5,983,125	A	11/1999	Alfano et al.	6,445,485	B1	9/2002	Frigo et al.
5,987,346	A	11/1999	Benaron et al.	6,445,939	B1	9/2002	Swanson et al.
5,991,697	A	11/1999	Nelson et al.	6,445,944	B1	9/2002	Ostrovsky
5,994,690	A	11/1999	Kulkarni et al.	6,459,487	B1	10/2002	Chen et al.
5,995,223	A	11/1999	Power	6,463,313	B1	10/2002	Winston et al.
6,002,480	A	12/1999	Izatt et al.	6,469,846	B2	10/2002	Ebizuka et al.
6,004,314	A	12/1999	Wei et al.	6,475,159	B1	11/2002	Casscells et al.
6,006,128	A	12/1999	Izatt et al.	6,475,210	B1	11/2002	Phelps et al.
6,007,996	A	12/1999	McNamara et al.	6,477,403	B1	11/2002	Eguchi et al.
6,010,449	A	1/2000	Selmon et al.	6,485,413	B1	11/2002	Boppart et al.
6,014,214	A	1/2000	Li	6,485,482	B1	11/2002	Belef
6,016,197	A	1/2000	Krivoshlykov	6,501,551	B1	12/2002	Tearney et al.
6,020,963	A	2/2000	Dimarzio et al.	6,501,878	B2	12/2002	Hughes et al.
6,025,956	A	2/2000	Nagano et al.	6,516,014	B1	2/2003	Sellin et al.
6,033,721	A	3/2000	Nassuphis	6,517,532	B1	2/2003	Altshuler et al.
6,037,579	A	3/2000	Chan et al.	6,538,817	B1	3/2003	Farmer et al.
6,044,288	A	3/2000	Wake et al.	6,540,391	B2	4/2003	Lanzetta et al.
6,045,511	A	4/2000	Ott et al.	6,549,801	B1	4/2003	Chen et al.
6,048,742	A	4/2000	Weyburne et al.	6,552,796	B2	4/2003	Magnin et al.
6,052,186	A	4/2000	Tsai	6,556,305	B1	4/2003	Aziz et al.
6,053,613	A	4/2000	Wei et al.	6,556,853	B1	4/2003	Cabib et al.
6,069,698	A	5/2000	Ozawa et al.	6,558,324	B1	5/2003	Von Behren et al.
6,078,047	A	6/2000	Mittleman et al.	6,560,259	B1	5/2003	Hwang et al.
6,091,496	A	7/2000	Hill	6,564,087	B1	5/2003	Pitris et al.
6,091,984	A	7/2000	Perelman et al.	6,564,089	B2	5/2003	Izatt et al.
6,094,274	A	7/2000	Yokoi	6,567,585	B2	5/2003	Harris
6,107,048	A	8/2000	Goldenring et al.	6,593,101	B2	7/2003	Richards-Kortum et al.
6,111,645	A	8/2000	Tearney et al.	6,611,833	B1	8/2003	Johnson et al.
6,117,128	A	9/2000	Gregory	6,615,071	B1	9/2003	Casscells, III et al.
6,120,516	A	9/2000	Selmon et al.	6,622,732	B2	9/2003	Constantz
6,134,003	A	10/2000	Tearney et al.	6,654,127	B2	11/2003	Everett et al.
6,134,010	A	10/2000	Zavislan	6,657,730	B2	12/2003	Pfau et al.
6,134,033	A	10/2000	Bergano et al.	6,658,278	B2	12/2003	Gruhl
6,141,577	A	10/2000	Rolland et al.	6,680,780	B1	1/2004	Fee
6,151,522	A	11/2000	Alfano et al.	6,685,885	B2	2/2004	Varma et al.
6,159,445	A	12/2000	Klaveness et al.	6,687,007	B1	2/2004	Meigs
6,160,826	A	12/2000	Swanson et al.	6,687,010	B1	2/2004	Horii et al.
6,161,031	A	12/2000	Hochmann et al.	6,687,036	B2	2/2004	Riza
6,166,373	A	12/2000	Mao	6,692,430	B2	2/2004	Adler
6,174,291	B1	1/2001	McMahon et al.	6,701,181	B2	3/2004	Tang et al.
6,175,669	B1	1/2001	Colston et al.	6,721,094	B1	4/2004	Sinclair et al.
6,185,271	B1	2/2001	Kinsinger	6,725,073	B1	4/2004	Motamedi et al.
6,191,862	B1	2/2001	Swanson et al.	6,738,144	B1	5/2004	Dogariu et al.
6,193,676	B1	2/2001	Winston et al.	6,741,355	B2	5/2004	Drabarek
6,198,956	B1	3/2001	Dunne	6,741,884	B1	5/2004	Freeman et al.
6,201,989	B1	3/2001	Whitehead et al.	6,757,467	B1	6/2004	Rogers
6,208,415	B1	3/2001	De Boer et al.	6,790,175	B1	9/2004	Furusawa et al.
6,208,887	B1	3/2001	Clarke	6,806,963	B1	10/2004	Wälti et al.
6,245,026	B1	6/2001	Campbell et al.	6,816,266	B2*	11/2004	Varshneya et al. .... 356/477
6,249,349	B1	6/2001	Lauer	6,816,743	B2	11/2004	Moreno et al.
6,249,381	B1	6/2001	Suganuma	6,831,781	B2	12/2004	Tearney et al.
				6,839,496	B1*	1/2005	Mills et al. .... 385/126
				6,882,432	B2	4/2005	Deck
				6,900,899	B2	5/2005	Nevis
				6,903,820	B2	6/2005	Wang

(56)

## References Cited

## U.S. PATENT DOCUMENTS

6,909,105 B1	6/2005	Heintzmann et al.	2002/0076152 A1	6/2002	Hughes et al.
6,949,072 B2	9/2005	Furnish et al.	2002/0085209 A1	7/2002	Mittleman et al.
6,961,123 B1	11/2005	Wang et al.	2002/0086347 A1	7/2002	Johnson et al.
6,980,299 B1	12/2005	de Boer	2002/0091322 A1	7/2002	Chaiken et al.
6,996,549 B2	2/2006	Zhang et al.	2002/0093662 A1	7/2002	Chen et al.
7,004,911 B1*	2/2006	Tu et al. .... 600/549	2002/0109851 A1	8/2002	Deck
7,006,231 B2	2/2006	Ostrovsky et al.	2002/0113965 A1	8/2002	Roche et al.
7,006,232 B2	2/2006	Rollins et al.	2002/0122182 A1	9/2002	Everett et al.
7,019,838 B2	3/2006	Izatt et al.	2002/0122246 A1	9/2002	Tearney et al.
7,027,633 B2	4/2006	Foran et al.	2002/0140942 A1	10/2002	Fee et al.
7,061,622 B2	6/2006	Rollins et al.	2002/0158211 A1	10/2002	Gillispie
7,072,047 B2	7/2006	Westphal et al.	2002/0161357 A1	10/2002	Anderson et al.
7,075,658 B2	7/2006	Izatt et al.	2002/0163622 A1	11/2002	Magnin et al.
7,099,358 B1	8/2006	Chong et al.	2002/0166946 A1	11/2002	Iizuka et al.
7,113,288 B2	9/2006	Fercher	2002/0168158 A1	11/2002	Furusawa et al.
7,113,625 B2	9/2006	Watson et al.	2002/0172485 A1	11/2002	Keaton et al.
7,130,320 B2	10/2006	Tobiason et al.	2002/0183623 A1	12/2002	Tang et al.
7,139,598 B2*	11/2006	Hull et al. .... 600/317	2002/0188204 A1	12/2002	McNamara et al.
7,142,835 B2	11/2006	Paulus	2002/0196446 A1	12/2002	Roth et al.
7,148,970 B2	12/2006	De Boer	2002/0198457 A1	12/2002	Tearney et al.
7,153,299 B1*	12/2006	Tu et al. .... 606/15	2003/0001071 A1	1/2003	Mandella et al.
7,177,027 B2	2/2007	Hirasawa et al.	2003/0013973 A1	1/2003	Georgakoudi et al.
7,190,464 B2	3/2007	Alphonse	2003/0023153 A1	1/2003	Izatt et al.
7,230,708 B2	6/2007	Lapotko et al.	2003/0025917 A1	2/2003	Suhami
7,231,243 B2	6/2007	Tearney et al.	2003/0026735 A1	2/2003	Nolte et al.
7,236,637 B2	6/2007	Sirohey et al.	2003/0028114 A1	2/2003	Casscells, III et al.
7,242,480 B2	7/2007	Alphonse	2003/0030816 A1	2/2003	Eom et al.
7,267,494 B2	9/2007	Deng et al.	2003/0043381 A1	3/2003	Fercher
7,272,252 B2	9/2007	De La Torre-Bueno et al.	2003/0053673 A1	3/2003	Dewaacle et al.
7,297,154 B2*	11/2007	Tu et al. .... 607/88	2003/0067607 A1	4/2003	Wolleschensky et al.
7,304,798 B2	12/2007	Izumi et al.	2003/0082105 A1	5/2003	Fischman et al.
7,310,150 B2	12/2007	Guillermo et al.	2003/0095263 A1*	5/2003	Varshneya et al. .... 356/477
7,330,270 B2	2/2008	O'Hara et al.	2003/0097048 A1	5/2003	Ryan et al.
7,336,366 B2	2/2008	Choma et al.	2003/0103212 A1	6/2003	Westphal et al.
7,342,659 B2	3/2008	Horn et al.	2003/0108911 A1	6/2003	Klimant et al.
7,349,618 B2*	3/2008	Nielsen et al. .... 385/138	2003/0120137 A1	6/2003	Pawluczyk et al.
7,355,716 B2	4/2008	De Boer et al.	2003/0135101 A1	7/2003	Webler
7,355,721 B2	4/2008	Quadling et al.	2003/0137669 A1	7/2003	Rollins et al.
7,359,062 B2	4/2008	Chen et al.	2003/0164952 A1	9/2003	Deichmann et al.
7,365,858 B2	4/2008	Fang-Yen et al.	2003/0165263 A1	9/2003	Hamer et al.
7,366,376 B2	4/2008	Shishkov et al.	2003/0171691 A1	9/2003	Casscells, III et al.
7,382,809 B2	6/2008	Chong et al.	2003/0174339 A1	9/2003	Feldchtein et al.
7,391,520 B2	6/2008	Zhou et al.	2003/0191392 A1	10/2003	Haldeman
7,458,683 B2	12/2008	Chernyak et al.	2003/0199769 A1	10/2003	Podoleanu et al.
7,519,261 B2*	4/2009	Nielsen et al. .... 385/138	2003/0216719 A1	11/2003	Debenedictis et al.
7,530,948 B2	5/2009	Seibel et al.	2003/0218756 A1	11/2003	Chen et al.
7,539,530 B2	5/2009	Caplan et al.	2003/0220749 A1	11/2003	Chen et al.
7,609,391 B2	10/2009	Betzig	2003/0236443 A1	12/2003	Cespedes et al.
7,630,083 B2	12/2009	de Boer et al.	2004/0002650 A1	1/2004	Mandrusov et al.
7,643,152 B2	1/2010	de Boer et al.	2004/0039252 A1	2/2004	Koch
7,643,153 B2	1/2010	de Boer et al.	2004/0039298 A1	2/2004	Abreu
7,646,905 B2	1/2010	Guitet et al.	2004/0052730 A1*	3/2004	Hochman .... 424/9.2
7,649,160 B2	1/2010	Colomb et al.	2004/0054268 A1	3/2004	Esenaliev et al.
7,664,300 B2	2/2010	Lange et al.	2004/0072200 A1	4/2004	Rigler et al.
7,733,497 B2	6/2010	Yun et al.	2004/0075841 A1	4/2004	Van Neste et al.
7,782,464 B2	8/2010	Mujat et al.	2004/0076940 A1	4/2004	Alexander et al.
7,799,558 B1	9/2010	Dultz	2004/0077949 A1	4/2004	Blofgett et al.
7,805,034 B2	9/2010	Kato et al.	2004/0085540 A1	5/2004	Lapotko et al.
7,822,299 B2*	10/2010	Borgos et al. .... 385/12	2004/0086245 A1	5/2004	Farroni et al.
7,911,621 B2	3/2011	Motaghiannezam et al.	2004/0095464 A1	5/2004	Miyagi et al.
7,969,578 B2	6/2011	Yun et al.	2004/0100631 A1	5/2004	Bashkansky et al.
7,973,936 B2	7/2011	Dantus	2004/0100681 A1	5/2004	Bjarklev et al.
8,315,282 B2	11/2012	Huber et al.	2004/0110206 A1	6/2004	Wong et al.
2001/0020126 A1	9/2001	Swanson et al.	2004/0126048 A1	7/2004	Dave et al.
2001/0036002 A1	11/2001	Tearney et al.	2004/0126120 A1	7/2004	Cohen et al.
2001/0047137 A1	11/2001	Moreno et al.	2004/0133191 A1	7/2004	Momiuchi et al.
2001/0055462 A1	12/2001	Seibel	2004/0150829 A1	8/2004	Koch et al.
2002/0016533 A1	2/2002	Marchitto et al.	2004/0150830 A1	8/2004	Chan
2002/0024015 A1	2/2002	Hoffmann et al.	2004/0152989 A1	8/2004	Puttappa et al.
2002/0037252 A1	3/2002	Toida et al.	2004/0165184 A1	8/2004	Mizuno
2002/0048025 A1	4/2002	Takaoka	2004/0166593 A1	8/2004	Nolte et al.
2002/0048026 A1	4/2002	Isshiki et al.	2004/0189999 A1	9/2004	De Groot et al.
2002/0052547 A1	5/2002	Toida	2004/0204651 A1	10/2004	Freeman et al.
2002/0057431 A1	5/2002	Fateley et al.	2004/0212808 A1	10/2004	Okawa et al.
2002/0064341 A1	5/2002	Fauver et al.	2004/0239938 A1	12/2004	Izatt et al.
			2004/0246490 A1	12/2004	Wang
			2004/0246583 A1	12/2004	Mueller et al.
			2004/0247268 A1	12/2004	Ishihara et al.
			2004/0254474 A1	12/2004	Seibel et al.

(56)

References Cited

U.S. PATENT DOCUMENTS

2004/0258106 A1 12/2004 Araujo et al.  
 2004/0263843 A1 12/2004 Knopp et al.  
 2005/0004453 A1 1/2005 Tearney et al.  
 2005/0018133 A1 1/2005 Huang et al.  
 2005/0018200 A1 1/2005 Guillermo et al.  
 2005/0018201 A1 1/2005 De Boer et al.  
 2005/0035295 A1 2/2005 Bouma et al.  
 2005/0036150 A1 2/2005 Izatt et al.  
 2005/0046837 A1 3/2005 Izumi et al.  
 2005/0049488 A1 3/2005 Homan  
 2005/0057680 A1 3/2005 Agan  
 2005/0057756 A1 3/2005 Fang-Yen et al.  
 2005/0059894 A1 3/2005 Zeng et al.  
 2005/0065421 A1 3/2005 Burckhardt et al.  
 2005/0075547 A1 4/2005 Wang  
 2005/0075704 A1\* 4/2005 Tu et al. .... 607/88  
 2005/0083534 A1 4/2005 Riza et al.  
 2005/0119567 A1 6/2005 Choi et al.  
 2005/0128488 A1 6/2005 Yelin et al.  
 2005/0165303 A1 7/2005 Kleen et al.  
 2005/0171438 A1 8/2005 Chen et al.  
 2005/0190372 A1 9/2005 Dogariu et al.  
 2005/0197530 A1 9/2005 Wallace et al.  
 2005/0221270 A1 10/2005 Connelly et al.  
 2005/0254059 A1 11/2005 Alphonse  
 2005/0254061 A1 11/2005 Alphonse et al.  
 2006/0020172 A1 1/2006 Luerssen et al.  
 2006/0033923 A1 2/2006 Hirasawa et al.  
 2006/0039004 A1 2/2006 De Boer et al.  
 2006/0093276 A1 5/2006 Bouma et al.  
 2006/0103850 A1 5/2006 Alphonse et al.  
 2006/0106375 A1 5/2006 Werneth et al.  
 2006/0146339 A1 7/2006 Fujita et al.  
 2006/0155193 A1 7/2006 Leonardi et al.  
 2006/0164639 A1 7/2006 Horn et al.  
 2006/0167363 A1 7/2006 Bernstein et al.  
 2006/0171503 A1 8/2006 O'Hara et al.  
 2006/0184048 A1\* 8/2006 Saadat ..... 600/478  
 2006/0189928 A1 8/2006 Camus et al.  
 2006/0193352 A1 8/2006 Chong et al.  
 2006/0224053 A1 10/2006 Black et al.  
 2006/0244973 A1 11/2006 Yun et al.  
 2006/0279742 A1 12/2006 Tearney  
 2007/0002435 A1 1/2007 Ye et al.  
 2007/0019208 A1 1/2007 Toida et al.  
 2007/0024860 A1 2/2007 Tobiason et al.  
 2007/0035743 A1 2/2007 Vakoc et al.  
 2007/0038040 A1 2/2007 Cense et al.  
 2007/0048818 A1 3/2007 Rosen et al.  
 2007/0070496 A1 3/2007 Gweon et al.  
 2007/0076217 A1 4/2007 Baker et al.  
 2007/0086013 A1 4/2007 De Lega et al.  
 2007/0086017 A1 4/2007 Buckland et al.  
 2007/0091317 A1 4/2007 Freischlad et al.  
 2007/0133002 A1 6/2007 Wax et al.  
 2007/0188855 A1 8/2007 Shishkov et al.  
 2007/0201031 A1\* 8/2007 Axelrod et al. .... 356/477  
 2007/0203404 A1 8/2007 Zysk et al.  
 2007/0208225 A1 9/2007 Czaniera et al.  
 2007/0223006 A1 9/2007 Tearney et al.  
 2007/0233056 A1 10/2007 Yun  
 2007/0233396 A1 10/2007 Tearney et al.  
 2007/0236700 A1 10/2007 Yun et al.  
 2007/0253673 A1\* 11/2007 Nielsen et al. .... 385/138  
 2007/0253901 A1 11/2007 Deng et al.  
 2007/0258094 A1 11/2007 Izatt et al.  
 2007/0263226 A1 11/2007 Kurtz et al.  
 2007/0291277 A1 12/2007 Everett et al.  
 2008/0002197 A1 1/2008 Sun et al.  
 2008/0007734 A1 1/2008 Park et al.  
 2008/0013960 A1 1/2008 Tearney et al.  
 2008/0021275 A1 1/2008 Tearney et al.  
 2008/0049220 A1 2/2008 Izzia et al.  
 2008/0070323 A1 3/2008 Hess et al.  
 2008/0094613 A1 4/2008 de Boer et al.

2008/0094637 A1 4/2008 de Boer et al.  
 2008/0097225 A1 4/2008 Tearney et al.  
 2008/0097709 A1 4/2008 de Boer et al.  
 2008/0100837 A1 5/2008 de Boer et al.  
 2008/0139906 A1 6/2008 Bussek et al.  
 2008/0152283 A1\* 6/2008 Nielsen et al. .... 385/81  
 2008/0152353 A1 6/2008 de Boer et al.  
 2008/0154090 A1 6/2008 Hashimshony  
 2008/0192236 A1 8/2008 Smith et al.  
 2008/0201081 A1 8/2008 Reid  
 2008/0204762 A1 8/2008 Izatt et al.  
 2008/0218696 A1 9/2008 Mir  
 2008/0226029 A1 9/2008 Weir et al.  
 2008/0228086 A1 9/2008 Ilegbusi  
 2008/0234560 A1 9/2008 Nomoto et al.  
 2008/0252901 A1 10/2008 Shimizu  
 2008/0265130 A1 10/2008 Colomb et al.  
 2008/0297806 A1 12/2008 Motachianezam  
 2008/0308730 A1 12/2008 Vizi et al.  
 2009/0004453 A1 1/2009 Murai et al.  
 2009/0005691 A1 1/2009 Huang  
 2009/0011948 A1 1/2009 Unlu et al.  
 2009/0012368 A1 1/2009 Banik et al.  
 2009/0044799 A1 2/2009 Qiu  
 2009/0051923 A1 2/2009 Zuluaga  
 2009/0131801 A1 5/2009 Suter et al.  
 2009/0192358 A1 7/2009 Jaffer et al.  
 2009/0196477 A1 8/2009 Cense et al.  
 2009/0209834 A1 8/2009 Fine  
 2009/0273777 A1 11/2009 Yun et al.  
 2009/0281390 A1 11/2009 QiuJun et al.  
 2009/0290156 A1 11/2009 Popescu et al.  
 2009/0305309 A1 12/2009 Chien et al.  
 2009/0306520 A1 12/2009 Schmitt et al.  
 2009/0323056 A1 12/2009 Yun et al.  
 2009/0326390 A1\* 12/2009 Belalcazar et al. .... 600/486  
 2010/0002241 A1 1/2010 Hirose  
 2010/0086251 A1 4/2010 Xu et al.  
 2010/0094576 A1 4/2010 de Boer et al.  
 2010/0145145 A1 6/2010 Shi et al.  
 2010/0150467 A1 6/2010 Zhao et al.  
 2010/0261995 A1 10/2010 Mckenna et al.  
 2011/0028967 A1 2/2011 Rollins et al.  
 2011/0160681 A1 6/2011 Dacey, Jr. et al.  
 2011/0178413 A1\* 7/2011 Schmitt et al. .... 600/478  
 2011/0182544 A1\* 7/2011 Lee ..... 385/12  
 2011/0218403 A1 9/2011 Tearney et al.  
 2012/0116255 A1\* 5/2012 Wang et al. .... 600/587  
 2014/0051948 A1\* 2/2014 LeBoeuf et al. .... 600/301  
 2014/0163392 A1\* 6/2014 Flanders ..... 600/480

FOREIGN PATENT DOCUMENTS

DE 4309056 9/1994  
 DE 19542955 5/1997  
 DE 10351319 6/2005  
 DE 102005034443 2/2007  
 EP 0110201 6/1984  
 EP 0251062 1/1988  
 EP 0617286 2/1994  
 EP 0590268 4/1994  
 EP 0697611 2/1996  
 EP 0728440 8/1996  
 EP 0933096 8/1999  
 EP 1324051 7/2003  
 EP 1426799 6/2004  
 EP 2149776 2/2010  
 FR 2738343 8/1995  
 GB 1257778 12/1971  
 GB 2030313 4/1980  
 GB 2209221 5/1989  
 GB 2298054 8/1996  
 JP 6073405 4/1985  
 JP 62-188001 6/1989  
 JP H2-5924 1/1990  
 JP 04-056907 2/1992  
 JP 20040056907 2/1992  
 JP 4135550 5/1992  
 JP 4135551 5/1992

(56) References Cited					
	FOREIGN PATENT DOCUMENTS				
JP	5509417	11/1993	WO	9201966	2/1992
JP	H8-136345	5/1996	WO	9216865	10/1992
JP	H08-160129	6/1996	WO	9216868	10/1992
JP	9-10213	1/1997	WO	9219930	11/1992
JP	9-230248	9/1997	WO	9303672	3/1993
JP	10-213485	8/1998	WO	9533971	12/1995
JP	10-267631	10/1998	WO	96-02184	2/1996
JP	10-267830	10/1998	WO	96-04839	2/1996
JP	2259617	10/1999	WO	9628212	9/1996
JP	2000-023978	1/2000	WO	9732182	9/1997
JP	2000-046729	2/2000	WO	9800057	1/1998
JP	2000-121961	4/2000	WO	9801074	1/1998
JP	2000-504234	4/2000	WO	9814132	4/1998
JP	2000-126116	5/2000	WO	9835203	8/1998
JP	2000-131222	5/2000	WO	9838907	9/1998
JP	2001-4447	1/2001	WO	9846123	10/1998
JP	2001-500026	1/2001	WO	9848838	11/1998
JP	2001-104315	4/2001	WO	9848846	11/1998
JP	2001-174404	6/2001	WO	9905487	2/1999
JP	2001-174744	6/2001	WO	9944089	2/1999
JP	2001-507251	6/2001	WO	99-28856	6/1999
JP	2001-508340	6/2001	WO	99-45838	9/1999
JP	2007-539336	6/2001	WO	9944089	9/1999
JP	2001-212086	8/2001	WO	1999-45338	10/1999
JP	2008-533712	8/2001	WO	9957507	11/1999
JP	2001-264246	9/2001	WO	00-42906	7/2000
JP	2001-515382	9/2001	WO	00-43730	7/2000
JP	2001-525580	12/2001	WO	0058766	10/2000
JP	2002-503134	1/2002	WO	01-04828	1/2001
JP	2002-035005	2/2002	WO	0101111	1/2001
JP	2002-205434	2/2002	WO	0108579	2/2001
JP	2002-095663	4/2002	WO	0127679	4/2001
JP	2002-113017	4/2002	WO	01-33215	5/2001
JP	2002-148185	5/2002	WO	0138820	5/2001
JP	2002-516586	6/2002	WO	01-42735	6/2001
JP	2002-214127	7/2002	WO	0142735	6/2001
JP	2002-214128	7/2002	WO	01-82786	11/2001
JP	2002214127	7/2002	WO	02-37075	5/2002
JP	2003-014585	1/2003	WO	0236015	5/2002
JP	2003-504627	2/2003	WO	0237075	5/2002
JP	20030035659	2/2003	WO	0238040	5/2002
JP	2003-512085	4/2003	WO	02-45572	6/2002
JP	2003-513278	4/2003	WO	02-68853	6/2002
JP	2003-516531	5/2003	WO	02053050	7/2002
JP	2004-028970	1/2004	WO	02054027	7/2002
JP	2004-037165	2/2004	WO	02-083003	10/2002
JP	2004-057652	2/2004	WO	0284263	10/2002
JP	2004-089552	3/2004	WO	03-003903	1/2003
JP	2004-113780	4/2004	WO	03-012405	2/2003
JP	2004-514920	5/2004	WO	03-013624	2/2003
JP	2004-258144	9/2004	WO	03013624	2/2003
JP	2004-317437	11/2004	WO	03020119	3/2003
JP	2005-062850	3/2005	WO	03046495	6/2003
JP	2005-110208	4/2005	WO	03046636	6/2003
JP	2005-510323	4/2005	WO	03052478	6/2003
JP	2005-156540	6/2005	WO	03053226	7/2003
JP	2005-516187	6/2005	WO	03062802	7/2003
JP	2005-195485	7/2005	WO	03-088826	10/2003
JP	2005-241872	9/2005	WO	03105678	12/2003
JP	2006-237359	9/2006	WO	2004034869	4/2004
JP	2006-288626	10/2006	WO	2004-037068	5/2004
JP	2007-500059	1/2007	WO	2004-043251	5/2004
JP	2007-075403	3/2007	WO	2004057266	7/2004
JP	2007-83053	4/2007	WO	2004066824	8/2004
JP	2007-524455	8/2007	WO	2004-073501	9/2004
JP	2007271761	10/2007	WO	2004088361	10/2004
JP	2010-508056	3/2010	WO	2004-100789	11/2004
JP	2003-102672	4/2012	WO	2004-105598	12/2004
RU	2149464	5/2000	WO	2004105598	12/2004
RU	2209094	7/2003	WO	2005000115	1/2005
RU	2213421	9/2003	WO	2005-045362	5/2005
RU	2242710	12/2004	WO	2005-047813	5/2005
RU	2255426	6/2005	WO	2005047813	5/2005
RU	2108122	6/2006	WO	2005054780	6/2005
WO	7900841	10/1979	WO	2005082225	9/2005
			WO	2005082225	9/2005
			WO	2006004749	1/2006
			WO	2006-020605	2/2006
			WO	2006014392	2/2006

(56) **References Cited**

## FOREIGN PATENT DOCUMENTS

WO	2006038876	4/2006
WO	2006039091	4/2006
WO	2006-050320	5/2006
WO	2006-058187	6/2006
WO	2006059109	6/2006
WO	2006124860	11/2006
WO	2006-131859	12/2006
WO	2006130797	12/2006
WO	2007-030835	3/2007
WO	2007028531	3/2007
WO	2007038787	4/2007
WO	2007083138	7/2007
WO	2007084995	7/2007
WO	WO 2007/140210 A2	12/2007
WO	WO 2008/053474 A2	5/2008
WO	2009-033064	3/2009
WO	2009153929	12/2009
WO	2011-055376	5/2011
WO	2011-080713	7/2011

## OTHER PUBLICATIONS

- R.H. Hardwich et al., (1995) "c-erbB-2 Overexpression in the Dysplasia/Carcinoma Sequence of Barrett's Oesophagus," *Journal of Clinical Pathology*, vol. 48, No. 2, pp. 129-132.
- W. Polkowski et al. (1998) Clinical Decision making in Barrett's Oesophagus can be supported by Computerized Immunoquantitation and Morphometry of Features Associated with Proliferation and Differentiation, *Journal of pathology*, vol. 184, pp. 161-168.
- J.R. Turner et al., MN Antigen Expression in Normal Preneoplastic, and Neoplastic Esophagus: A Clinicopathological Study of a New Cancer-Associated Biomarker.; Jun. 1997, *Human Pathology*, vol. 28, No. 6, pp. 740-744.
- D.J. Bowery et al., (1999) "Patterns of Gastritis in Patients with Gastro-Oesophageal Reflux Disease,," *Gut*, vol. 45, pp. 798-803.
- O'Reich et al., (2000) "Expression of Oestrogen and Progesterone Receptors in Low-Grade Endometrial Stromal Sarcomas,," *British Journal of Cancer*, vol. 82, No. 5, pp. 1030-1034
- M.I. Canto et al., (1999) "Vital Staining and Barrett's Esophagus,," *Gastrointestinal Endoscopy*, vol. 49, No. 3, Part 2, pp. S12-S16.
- S. Jackle et al., (2000) "In Vivo Endoscopic Optical Coherence Tomography of the Human Gastrointestinal Tract-Toward Optical Biopsy,," *Endoscopy*, vol. 32, No. 10, pp. 743-749.
- E. Montgomey et al., "Reproducibility of the Diagnosis of Dysplasia in Barrett Esophagus: A Reaffirmation,," *Apr. 2001, Human Pathology*, vol. 32, No. 4, pp. 368-378.
- H. Geddert et al., "Expression of Cyclin B1 in the Metaplasia-Dysphasia-Carcinoma Sequence of Barrett Esophagus,," *Jan. 2002, Cancer*, vol. 94, No. 1, pp. 212-218.
- P. Pfau et al., (2003) "Criteria for the Diagnosis of Dysphasia by Endoscopic Optical Coherence Tomography,," *Gastrointestinal Endoscopy*, vol. 58, No. 2, pp. 196-2002.
- R. Kiesslich et al., (2004) "Confocal Laser Endoscopy for Diagnosing Intraepithelial Neoplasias and Colorectal Cancer in Vivo,," *Gastroenterology*, vol. 127, No. 3, pp. 706-713.
- X. Qi et al., (2004) "Computer Aided Diagnosis of Dysphasia in Barrett's Esophagus Using Endoscopic Optical Coherence Tomography,," *SPIE, Coherence Domain Optical Methods and Optical Coherence Tomography in Biomedicine VIII. Proc. of Conference on*, vol. 5316, pp. 33-40.
- Seltzer et al., (1991) "160 nm Continuous Tuning of a MQW Laser in an External Cavity Across the Entire 1.3  $\mu$ m Communications Window,," *Electronics Letters*, vol. 27, pp. 95-96.
- Office Action dated Jan. 25, 2010 for U.S. Appl. No. 11/537,048.
- International Search Report dated Jan. 27, 2010 for PCT/US2009/050553.
- International Search Report dated Jan. 27, 2010 for PCT/US2009/047988.
- International Search Report dated Feb. 23, 2010 for U.S. Appl. No. 11/445,131.
- Office Action dated Mar. 18, 2010 of U.S. Appl. No. 11/844,454.
- Office Action dated Apr. 8, 2010 of U.S. Appl. No. 11/414,564.
- Japanese Office Action dated Apr. 13, 2010 for Japanese Patent application No. 2007-515029.
- International Search Report dated May 27, 2010 for PCT/US2009/063420.
- Office Action dated May 28, 2010 for U.S. Appl. No. 12/015,642.
- Office Action dated Jun. 2, 2010 for U.S. Appl. No. 12/112,205.
- Office Action dated Jul. 7, 2010 for U.S. Appl. No. 11/624,277.
- Montag Ethan D., "Parts of the Eye" online textbook for JIMG 774: Vision & Psychophysics, downloaded on Jun. 23, 2010 from [http://www.cis.rit.edu/people/faculty/montag/vandplite/pages/chap\\_8/ch8p3.html](http://www.cis.rit.edu/people/faculty/montag/vandplite/pages/chap_8/ch8p3.html).
- Office Action dated Jul. 16, 2010 for U.S. Appl. No. 11/445,990.
- Office Action dated Jul. 20, 2010 for U.S. Appl. No. 11/625,135.
- Office Action dated Aug. 5, 2010 for U.S. Appl. No. 11/623,852.
- Chinese office action dated Aug. 4, 2010 for CN 200780005949.9.
- Chinese office action dated Aug. 4, 2010 for CN 200780016266.3.
- Zhang et al., "Full Range Polarization-Sensitive Fourier Domain Optical Coherence Tomography" *Optics Express*, Nov. 29, 2004, vol. 12, No. 24.
- Office Action dated Aug. 27, 2010 for U.S. Appl. No. 11/569,790.
- Office Action dated Aug. 31, 2010 for U.S. Appl. No. 11/677,278.
- Office Action dated Sep. 3, 2010 for U.S. Appl. No. 12/139,314.
- Yong Zhao et al: "Virtual Data Grid Middleware Services for Data-Intensive Science", *Concurrency and Computation: Practice and Experience*, Wiley, London, GB, Jan. 1, 2000, pp. 1-7, pp. 1532-0626.
- Swan et al., "Toward Nanometer-Scale Resolution in Fluorescence Microscopy using Spectral Self-Interference *IEEE Journal. Selected Topics in Quantum Electronics*" 9 (2) 2003, pp. 294-300.
- Moiseev et al., "Spectral Self-Interference Fluorescence Microscopy", *J. Appl. Phys.* 96 (9) 2004, pp. 5311-5315.
- Hendrik Verschueren, "Interference Reflection Microscopy in Cell Biology", *J. Cell Sci.* 75, 1985, pp. 289-301.
- Park et al., "Diffraction Phase and Fluorescence Microscopy", *Opt. Expr.* 14 (18) 2006, pp. 8263-8268.
- Swan et al., "High Resolution Spectral Self-Interference Fluorescence Microscopy", *Proc. SPIE* 4621, 2002, pp. 77-85.
- Sanchez et al., "Near-Field Fluorescence Microscopy Based on Two-Photon Excitation with Metal Tips", *Phys. Rev. Lett.* 82 (20) 1999, pp. 4014-4017.
- Wojkowski, Maciej, Ph.D. "Three-Dimensional Retinal Imaging with High-Speed Ultrahigh-Resolution Optical Coherence Tomography" *Ophthalmology*, Oct. 2005, 112(10): 1734-1746.
- Vaughan, J.M. et al., "Brillouin Scattering, Density and Elastic Properties of the Lens and Cornea of the Eye", *Nature*, vol. 284, Apr. 3, 1980, pp. 489-491.
- Hess, S.T. et al. "Ultra-high Resolution Imaging by Fluorescence Photoactivation Localization Microscopy" *Biophysical Journal* vol. 91, Dec. 2006, 4258-4272.
- Fernandez-Suarez M. et a., "Fluorescent Probes for Super-Resolution Imaging in Living Cells" *Nature Reviews Molecular Cell Biology* vol. 9, Dec. 2008.
- Extended European Search Report mailed Dec. 14, 2010 for EP 10182301.1.
- S. Hell et al., "Breaking the diffraction resolution limit by stimulated-emission-stimulated-emission-depletion fluorescence microscopy," *Optics Letters*. 19:495 (1995) and *Ground State Depletion (GSD)*.
- S. Hell et al. "Ground-State-Depletion fluorescence microscopy—a concept for breaking the diffraction resolution limit," *Applied Physics B*. 60:780 (1994) fluorescence microscopy, photo-activated localization microscopy (PALM).
- E. Betzig et al. "Imaging intracellular fluorescent proteins at nanometer resolution," *Science* 313:1642 (2006), stochastic optical reconstruction microscopy (STORM).
- M. Rust et al. "Sub-diffraction-limited imaging by stochastic optical reconstruction microscopy (STORM)," *Nature Methods* 3:783 (2006), and structured illumination microscopy (SIM).
- B. Bailey et al. "Enhancement of Axial Resolution in Fluorescence Microscopy by Standing-Wave Excitation," *Nature* 366:44 (1993).

(56) **References Cited**

## OTHER PUBLICATIONS

- M. Gustafsson "Surpassing the lateral resolution limit by a factor of two using structured illumination microscopy," *Journal of Microscopy* 198:82 (2000).
- M. Gustafsson "Nonlinear structured illumination microscopy: Wide-field fluorescence imaging with theoretically unlimited resolution," *PNAS* 102:13081 (2005).
- R. Thompson et al. "Precise nanometer localization analysis for individual fluorescent probes," *Biophysical Journal* 82:2775 (2002).
- K. Drabe et al. "Localization of Spontaneous Emission in front of a mirror," *Optics Communications* 73:91 (1989).
- Swan et al. "Toward nanometer-scale resolution in fluorescence microscopy using spectral self-interference," *IEEE Quantum Electronics* 9:294 (2003).
- C. Joo, et al. "Spectral Domain optical coherence phase and multiphoton microscopy," *Optics Letters* 32:623 (2007).
- Virmani et al., "Lesions from sudden coronary death: A comprehensive morphological classification scheme for atherosclerotic lesions," *Arterioscler. Thromb. Vase. Bio.*, 20:1262-75 (2000).
- Gonzalez, R.C. and Wintz, P., "Digital Image Processing" Addison-Wesley Publishing Company, Reading MA, 1987.
- V. Tuchin et al., "Speckle interferometry in the measurements of biological tissues vibrations," *SPIE*, 1647: 125 (1992).
- A.A. Bednov et al., "Investigation of Statistical Properties of Lymph Flow Dynamics Using Speckle-Microscopy," *SPIE*, 2981: 181-90 (1997).
- Feng et al., "Mesoscopic Conductors and Correlations in Laser Speckle Patterns" *Science, New Series*, vol. 251, No. 4994, pp. 633-639 (Feb. 8, 1991).
- Lee et al., "The Unstable Atheroma," *Arteriosclerosis, Thrombosis & Vascular Biology*, 17:1859-67 (1997).
- International Search report dated Apr. 29, 2011 for PCT/US2010/051715.
- International Search report dated Sep. 13, 2010 for PCT/US2010/023215.
- International Search Report dated Jul. 28, 2011 for PCT/US2010/059534.
- International Search report dated Nov. 18, 2011 for PCT/US2011/027450.
- International Search report dated Nov. 18, 2011 for PCT/US2011/027437.
- International Search report dated Nov. 22, 2011 for PCT/US2011/027421.
- Liptak David C. et al., (2007) "On the Development of a Confocal Rayleigh-Brillouin Microscope" *American Institute of Physics* vol. 78, 016106.
- Office Action mailed Oct. 1, 2008 for U.S. Appl. No. 11/955,986.
- Invitation of Pay Additional Fees mailed Aug. 7, 2008 for International Application No. PCT/US2008/062354.
- Invitation of Pay Additional Fees mailed Jul. 20, 2008 for International Application No. PCT/US2007/081982.
- International Search Report and Written Opinion mailed Mar. 7, 2006 for PCT/US2005/035711.
- International Search Report and Written Opinion mailed Jul. 18, 2008 for PCT/US2008/057533.
- Aizu, Y et al. (1991) "Bio-Speckle Phenomena and Their Application to the Evaluation of Blood Flow" *Optics and Laser Technology*, vol. 23, No. 4, Aug. 1, 1991.
- Richards G.J. et al. (1997) "Laser Speckle Contrast Analysis (LASCA): A Technique for Measuring Capillary Blood Flow Using the First Order Statistics of Laser Speckle Patterns" Apr. 2, 1997.
- Gonick, Maria M., et al (2002) "Visualization of Blood Microcirculation Parameters in Human Tissues by Time Integrated Dynamic Speckles Analysis" vol. 972, No. 1, Oct. 1, 2002.
- International Search Report and Written Opinion mailed Jul. 4, 2008 for PCT/US2008/051432.
- Jonathan, Enock (2005) "Dual Reference Arm Low-Coherence Interferometer-Based Reflectometer for Optical Coherence Tomography (OCT) Application" *Optics Communications* vol. 252.
- Motaghian Nezam, S.M.R. (2007) "increased Ranging Depth in optical Frequency Domain Imaging by Frequency Encoding" *Optics Letters*, vol. 32, No. 19, Oct. 1, 2007.
- Office Action dated Jun. 30, 2008 for U.S. Appl. No. 11/670,058.
- Office Action dated Jul. 7, 2008 for U.S. Appl. No. 10/551,735.
- Australian Examiner's Report mailed May 27, 2008 for Australian patent application No. 2003210669.
- Notice of Allowance mailed Jun. 4, 2008 for U.S. Appl. No. 11/174,425.
- European communication dated May 15, 2008 for European patent application No. 05819917.5.
- International Search Report and Written Opinion mailed Jun. 10, 2008 for PCT/US2008/051335.
- Oh, W.Y. et al (2006) "Ultrahigh-Speed Optical Frequency Domain Imaging and Application to laser Ablation Monitoring" *Applied Physics Letters*, vol. 88.
- Office Action dated Aug. 21, 2008 for U.S. Appl. No. 11/505,700.
- Sticker, Markus (2002) *En Face Imaging of Single Cell layers by Differential Phase-Contrast Optical Coherence Microscopy* *Optics Letters*, col. 27, No. 13, Jul. 1, 2002.
- International Search Report and Written Opinion dated Jul. 17, 2008 for International Application No. PCT/US2008/057450.
- International Search Report and Written Opinion dated Aug. 11, 2008 for International Application No. PCT/US2008/058703.
- US National Library of Medicine (NLM), Bethesda, MD, US; Oct. 2007 (Oct. 2007), "Abstracts of the 19<sup>th</sup> Annual Symposium of Transcatheter Cardiovascular Therapeutics, Oct. 20-25, 2007, Washington, DC, USA."
- International Search Report and Written Opinion dated May 26, 2008 for International Application No. PCT/US2008/051404.
- Office Action dated Aug. 25, 2008 for U.S. Appl. No. 11/264,655.
- Office Action dated Sep. 11, 2008 for U.S. Appl. No. 11/624,334.
- Office Action dated Aug. 21, 2008 for U.S. Appl. No. 11/956,079.
- Gelikono, V. M. et al. Oct. 1, 2004 "Two-Wavelength Optical Coherence Tomography" *Radio physics and Quantum Electronics, Kluwer Academic Publishers—Consultants*. vol. 47, No. 10-1.
- International Search Report and Written Opinion for PCT/US2007/081982 dated Oct. 19, 2007.
- Database Compendex Engineering Information, Inc., New York, NY, US; Mar. 5, 2007, Yelin, Dvir et al: "Spectral-Domain Spectrally-Encoded Endoscopy".
- Database Biosis Biosciences Information Service, Philadelphia, PA, US; Oct. 2006, Yelin D. et al: "Three-Dimensional Miniature Endoscopy".
- International Search Report and Written Opinion mailed Mar. 14, 2005 for PCT/US2004/018045.
- Notification of the international Preliminary Report on Patentability mailed Oct. 21, 2005.
- Shim M.G. et al., "Study of Fiber-Optic Probes for in vivo Medical Raman Spectroscopy" *Applied Spectroscopy*. vol. 53, No. 6, Jun. 1999.
- Bingdi U. et al., "Fibre-Optic Laser-Assisted Infrared Tumour Diagnostics (FLAIR); Infrared Tumour Diagnostics" *Journal of Physics D. Applied Physics*, vol. 38, No. 15, Aug. 7, 2005.
- Jun Zhang et al. "Full Range Polarization-Sensitive Fourier Domain Optical Coherence Tomography" *Optics Express*, vol. 12, No. 24, Nov. 29, 2004.
- Yonghua et al., "Real-Time Phase-Resolved Functional Optical Hilbert Transformation" *Optics Letters*, vol. 27, No. 2, Jan. 15, 2002.
- Siavash et al., "Self-Referenced Doppler Optical Coherence Tomography" *Optics Letters*, vol. 27, No. 23, Dec. 1, 2002.
- International Search Report and Written Opinion dated Dec. 20, 2004 for PCT/US04/10152.
- Notification Concerning Transmittal of International Preliminary Report on Patentability dated Oct. 13, 2005 for PCT/US04/10152.
- International Search Report and Written Opinion dated Mar. 23, 2006 for PCT/US2005/042408.
- International Preliminary Report on Patentability dated Jun. 7, 2007 for PCT/US2005/042408.
- International Search Report and Written Opinion dated Feb. 28, 2007 for International Application No. PCT/US2006/038277.

(56)

## References Cited

## OTHER PUBLICATIONS

- International Search Report and Written Opinion dated Jan. 30, 2009 for International Application No. PCT/US2008/081834.
- Fox, J.A. et al; "A New Galvanometric Scanner for Rapid tuning of CO<sub>2</sub> Lasers" New York, IEEE, US vol. Apr. 7, 1991.
- Motaghian Nezam, S.M. et al: "High-speed Wavelength-Swept Semiconductor laser using a Diffraction Grating and a Polygon Scanner in Littro Configuration" *Optical Fiber Communication and the National Fiber Optic Engineers Conference* Mar. 29, 2007.
- International Search Report and Written Opinion dated Feb. 2, 2009 for International Application No. PCT/US2008/071786.
- Bilenca A et al: "The Role of Amplitude and phase in Fluorescence Coherence Imaging: From Wide Filed to Nanometer Depth Profiling", *Optics IEEE*, May 5, 2007.
- Inoue, Yusuke et al: "Variable Phase-Contrast Fluorescence Spectrometry for Fluorescently Strained Cells", *Applied Physics Letters*, Sep. 18, 2006.
- Bernet, S et al: "Quantitative Imaging of Complex Samples by Spiral Phase Contrast Microscopy", *Optics Express*, May 9, 2006.
- International Search Report and Written Opinion dated Jan. 15, 2009 for International Application No. PCT/US2008/074863.
- Office Action dated Feb. 17, 2009 for U.S. Appl. No. 11/211,483. Notice of Reasons for Rejection mailed Dec. 2, 2008 for Japanese patent application No. 2000-533782.
- International Search Report and Written Opinion dated Feb. 24, 2009 for PCT/US2008/076447.
- European Official Action dated Dec. 2, 2008 for EP 07718117.0.
- Barfuss et al (1989) "Modified Optical Frequency Domain Reflectometry with High spatial Resolution for Components of integrated optic Systems", *Journal of Lightwave Technology*, IEEE vol. 7., No. 1.
- Yun et al., (2004) "Removing the Depth-Degeneracy in Optical Frequency Domain Imaging with Frequency Shifting", *Optics Express*, vol. 12, No. 20.
- International Search Report and Written Opinion dated Jun. 10, 2009 for PCT/US08/075456.
- European Search Report issued May 5, 2009 for European Application No. 01991471.2.
- Motz, J.T. et al: "Spectral- and Frequency-Encoded Fluorescence Imaging" *Optics Letters*, OSA, Optical Society of America, Washington, DC, US, vol. 30, No. 20, Oct. 15, 2005, pp. 2760-2762.
- Japanese Notice of Reasons for Rejection dated Jul. 14, 2009 for Japanese Patent application No. 2006-503161.
- Office Action dated Aug. 18, 2009 for U.S. Appl. No. 12/277,178.
- Office Action dated Aug. 13, 2009 for U.S. Appl. No. 10/136,813.
- Office Action dated Aug. 6, 2009 for U.S. Appl. No. 11/624,455.
- Office Action dated May 15, 2009 for U.S. Appl. No. 11/537,123.
- Office Action dated Apr. 17, 2009 for U.S. Appl. No. 11/537,343.
- Office Action dated Apr. 15, 2009 for U.S. Appl. No. 12/205,775.
- Office Action dated Dec. 9, 2008 for U.S. Appl. No. 09/709,162.
- Office Action dated Dec. 23, 2008 for U.S. Appl. No. 11/780,261.
- Office Action dated Jan. 9, 2010 for U.S. Appl. No. 11/624,455.
- Office Action dated Feb. 18, 2009 for U.S. Appl. No. 11/285,301.
- Beddow et al, (May 2002) "Improved Performance Interferometer Designs for Optical Coherence Tomography", IEEE Optical Fiber Sensors Conference, pp. 527-530.
- Yagoob et al., (Jun. 2002) "High-Speed Wavelength-Multiplexed Fiber-Optic Sensors for Biomedicine," *Sensors Proceedings of the IEEE*, pp. 325-330.
- Office Action dated Feb. 18, 2009 for U.S. Appl. No. 11/697,012.
- Zhang et al, (Sep. 2004), "Fourier Domain Functional Optical Coherence Tomography". Saratov Fall Meeting 2004, pp. 8-14.
- Office Action dated Feb. 23, 2009 for U.S. Appl. No. 11/956,129.
- Office Action dated Mar. 16, 2009 for U.S. Appl. No. 11/621,694.
- Office Action dated Oct. 1, 2009 for U.S. Appl. No. 11/677,278.
- Office Action dated Oct. 6, 2009 for U.S. Appl. No. 12/015,642.
- Lin, Stollen et al., (1977) "A CW Tunable Near-infrared (1.085-1.175-um) Raman Oscillator," *Optics Letters*, vol. 1, 96.
- Summons to attend Oral Proceedings dated Oct. 9, 2009 for European patent application No. 06813365.1.
- Office Action dated Dec. 15, 2009 for U.S. Appl. No. 11/549,397.
- Fujimoto et al., "High Resolution in Vivo Intra-Arterial Imaging with Optical Coherence Tomography," *Official Journal of the British Cardiac Society*, vol. 82, pp. 128-133 Heart, 1999.
- D. Huang et al., "Optical Coherence Tomography," *Science*, vol. 254, pp. 1178-1181, Nov. 1991.
- Tearney et al., "High-Speed Phase—and Group Delay Scanning with a Grating Based Phase Control Delay Line," *Optics Letters*, vol. 22, pp. 1811-1813, Dec. 1997.
- Rollins, et al., "In Vivo Video Rate Optical Coherence Tomography," *Optics Express*, vol. 3, pp. 219-229, Sep. 1998
- Saxer, et al., High Speed Fiber-Based Polarization-Sensitive Optical Coherence Tomography of in Vivo Human Skin, *Optical Society of America*, vol. 25, pp. 1355-1357, Sep. 2000.
- Oscar Eduardo Martinez, "3000 Times Grating Compress or with Positive Group Velocity Dispersion," *IEEE*, vol. QE-23, pp. 59-64, Jan. 1987.
- Kulkarni, et al., "Image Enhancement in Optical Coherence Tomography Using Deconvolution," *Electronics Letters*, vol. 33, pp. 1365-1367, Jul. 1997.
- Bashkansky, et al., "Signal Processing for Improving Field Cross-Correlation Coherence Function in Optical Coherence Tomography," *Optics & Photonics News*, vol. 9, pp. 8137-8138, May 1998.
- Yung et al., "Phase-Domain Processing of Optical Coherence Tomography Images," *Journal of Biomedical Optics*, vol. 4, pp. 125-136, Jan. 1999.
- Tearney, et al., "In Vivo Endoscopic Optical Biopsy with Optical Coherence Tomography," *Science*, vol. 276, Jun. 1997
- W. Drexler et al., "In Vivo Ultrahigh-Resolution Optical Coherence Tomography," *Optics Letters* vol. 24, pp. 1221-1123, Sep. 1999
- Nicuser V. Ifimia et al., (2005) "A Portable, Low Coherence Interferometry Based Instrument for Fine Needle Aspiration Biopsy Guidance," Accepted to Review of Scientific Instruments, published May 23, 2005.
- Abbas, G.L., V.W.S. Chan et al., "Local-Oscillator Excess-Noise Suppression for Homodyne and Heterodyne-Detection," *Optics Letters*, vol. 8, pp. 419-421, Aug. 1983 issue.
- Agrawal, G.P., "Population Pulsations and Nondegenerate 4-Wave Mixing in Semiconductor-Lasers and Amplifiers," *Journal of the Optical Society of America B-Optical Physics*, vol. 5, pp. 147-159, Jan. 1998.
- Andretzky, P. et al., "Optical Coherence Tomography by Spectral Radar: Improvement of Signal-to-Noise Ratio," *The International Society for Optical Engineering*, USA, vol. 3915, 2000.
- Ballif, J. et al., "Rapid and Scalable Scans at 21 m/s in optical Low-Coherence Reflectometry," *Optics Letters*, vol. 22, pp. 757-759, Jun. 1997.
- Barfuss H. et al., "Modified Optical Frequency-Domain Reflectometry with High Spatial-Resolution for Components of Integrated Optic Systems," *Journal of Lightwave Technology*, vol. 7, pp. 3-10, Jan. 1989.
- Beaud, P. et al., "Optical Reflectometry with Micrometer Resolution for the Investigation of Integrated Optical-Devices," *IEEE Journal of Quantum Electronics*, vol. 25, pp. 755-759, Apr. 1989.
- Bouma, Brett et al., "Power-Efficient Nonreciprocal Interferometer and Linear-Scanning Fiber-Optic Catheter for Optical Coherence Tomography," *Optics Letters*, vol. 24, pp. 531-533, Apr. 1999.
- Brinkmeyer, E. et al., "Efficient Algorithm for Non-Equidistant Interpolation of Sampled Data," *Electronics Letters*, vol. 28, p. 693, Mar. 1992.
- Brinkmeyer, E. et al., "High-Resolution OADR in Dispersive Wave-Guides," *Electronics Letters*, vol. 26, pp. 413-414, Mar. 1990.
- Chinn, S.R. et al., "Optical Coherence Tomography Using a Frequency-Tunable Optical Source," *Optics Letters*, vol. 22, pp. 340-342, Mar. 1997.
- Danielson, B.L. et al., "Absolute Optical Ranging Using Low Coherence Interferometry," *Applied Optics*, vol. 30, p. 2975, Jul. 1991.
- Dorrer, C. et al., "Spectral Resolution and Sampling Issues in Fourier-Transform Spectral Interferometry," *Journal of the Optical Society of America B—Optical Physics*, vol. 17, pp. 1795-1802, Oct. 2000.

(56)

## References Cited

## OTHER PUBLICATIONS

- Dudley, J.M. et al., "Cross-Correlation Frequency Resolved Optical Gating Analysis of Broadband Continuum Generation in Photonic Crystal Fiber: Simulations and Experiments," *Optics Express*, vol. 10, p. 1215, Oct. 2002.
- Eickhoff, W. et al., "Optical Frequency-Domain Reflectometry in Single-Mode Fiber," *Applied Physics Letters*, vol. 39, pp. 693-695, 1981.
- Fercher, Adolf "Optical Coherence Tomography," *Journal of Biomedical Optics*, vol. 1, pp. 157-173, Apr. 1996.
- Ferreira, L.A. et al., "Polarization-Insensitive Fiberoptic White-Light Interferometry," *Optics Communications*, vol. 114, pp. 386-392, Feb. 1995.
- Fujii, Yohji, "High-Isolation Polarization-Independent Optical Circulator," *Journal of Lightwave Technology*, vol. 9, pp. 1239-1243, Oct. 1991.
- Glance, B., "Polarization Independent Coherent Optical Receiver," *Journal of Lightwave Technology*, vol. LT-5, p. 274, Feb. 1987.
- Glombitza, U., "Coherent Frequency-Domain Reflectometry for Characterization of Single-Mode Integrated-Optical Wave-Guides," *Journal of Lightwave Technology*, vol. 11, pp. 1377-1384, Aug. 1993.
- Golubovic, B. et al., "Optical Frequency-Domain Reflectometry Using Rapid Wavelength Tuning of a Cr<sup>4+</sup>:Forsterite Laser," *Optics Letters*, vol. 11, pp. 1704-1706, Nov. 1997.
- Haberland, U. H. P. et al., "Chirp Optical Coherence Tomography of Layered Scattering Media," *Journal of Biomedical Optics*, vol. 3, pp. 259-266, Jul. 1998.
- Hammer, Daniel X. et al., "Spectrally Resolved White-Light Interferometry for Measurement of Ocular Dispersion," *Journal of the Optical Society of America A—Optics Image Science and Vision*, vol. 16, pp. 2092-2102, Sep. 1999.
- Harvey, K. C. et al., "External-Cavity Diode-Laser Using a Grazing-Incidence Diffraction Grating," *Optics Letters*, vol. 16, pp. 910-912, Jun. 1991.
- Hausler, Gerd et al., "'Coherence Radar' and 'Spectral Radar' New Tools for Dermatological Diagnosis," *Journal of Biomedical Optics*, vol. 3, pp. 21-31, Jan. 1998.
- Hee, Michael R. et al., "Polarization-Sensitive Low-Coherence Reflectometer for Birefringence Characterization and Ranging," *Journal of the Optical Society of America B (Optical Physics)*, vol. 9, p. 903-908, Jun. 1992.
- Hotate Kazuo et al., "Optical Coherence Domain Reflectometry by Synthesis of Coherence Function," *Journal of Lightwave Technology*, vol. 11, pp. 1701-1710, Oct. 1993.
- Inoue, Kyo et al., "Nearly Degenerate 4-Wave-Mixing in a Traveling-Wave Semiconductor-Laser Amplifier," *Applied Physics Letters*, vol. 51, pp. 1051-1053, 1987.
- Ivanov, A. P. et al., "New Method for High-Range Resolution Measurements of Light Scattering in Optically Dense Inhomogeneous Media," *Optics Letters*, vol. 1, pp. 226-228, Dec. 1977.
- Ivanov, A. P. et al., "Interferometric Study of the Spatial Structure of a Light-Scattering Medium," *Journal of Applied Spectroscopy*, vol. 28, pp. 518-525, 1978.
- Kazovsky, L. G. et al., "Heterodyne Detection Through Rain, Snow, and Turbid Media: Effective Receiver Size at Optical Through Millimeter Wavelengths," *Applied Optics*, vol. 22, pp. 706-710, Mar. 1983.
- Kersey, A. D. et al., "Adaptive Polarization Diversity Receiver Configuration for Coherent Optical Fiber Communications," *Electronics Letters*, vol. 25, pp. 275-277, Feb. 1989.
- Kohlhaas, Andreas et al., "High-Resolution OCDR for Testing Integrated-Optical Waveguides: Dispersion-Corrupted Experimental Data Corrected by a Numerical Algorithm," *Journal of Lightwave Technology*, vol. 9, pp. 1493-1502, Nov. 1991.
- Larkin, Kieran G., "Efficient Nonlinear Algorithm for Envelope Detection in White Light Interferometry," *Journal of the Optical Society of America A—Optics Image Science and Vision*, vol. 13, pp. 832-843, Apr. 1996.
- Leitgeb, R. et al., "Spectral measurement of Absorption by Spectroscopic Frequency-Domain Optical Coherence Tomography," *Optics Letters*, vol. 25, pp. 820-822, Jun. 2000.
- Lexer, F. et al., "Wavelength-Tuning Interferometry of Intraocular Distances," *Applied Optics*, vol. 36, pp. 6548-6553, Sep. 1997.
- Mitsui, Takahisa, "Dynamic Range of Optical Reflectometry with Spectral Interferometry," *Japanese Journal of Applied Physics Part 1—Regular Papers Short Notes & Review Papers*, vol. 38, pp. 6133-6137, 1999.
- Naganuma, Kazunori et al., "Group-Delay Measurement Using the Fourier-Transform of an Interferometric Cross-Correlation Generated by White Light," *Optics Letters*, vol. 15, pp. 393-395, Apr. 1990.
- Okoshi, Takahisa, "Polarization-State Control Schemes for Heterodyne or Homodyne Optical Fiber Communications," *Journal of Lightwave Technology*, vol. LT-3, pp. 1232-1237, Dec. 1995.
- Passy, R. et al., "Experimental and Theoretical Investigations of Coherent OFDR with Semiconductor-Laser Sources," *Journal of Lightwave Technology*, vol. 12, pp. 1622-1630, Sep. 1994.
- Podoleanu, Adrian G., "Unbalanced Versus Balanced Operation in an Optical Coherence Tomography System," *Applied Optics*, vol. 39, pp. 173-182, Jan. 2000.
- Price, J. H. V. et al., "Tunable, Femtosecond Pulse Source Operating in the Range 1.06-1.33  $\mu\text{m}$  Based on an Yb<sup>3+</sup>-doped Holey Fiber Amplifier," *Journal of the Optical Society of America B—Optical Physics*, vol. 19, pp. 1286-1294, Jun. 2002.
- Schmitt, J. M. et al., "Measurement of Optical-Properties of Biological Tissues by Low-Coherence Reflectometry," *Applied Optics*, vol. 32, pp. 6032-6042, Oct. 1993.
- Silberberg, Y. et al., "Passive-Mode Locking of a Semiconductor Diode-Laser," *Optics Letters*, vol. 9, pp. 507-509, Nov. 1984.
- Smith, L. Montgomery et al., "Absolute Displacement Measurements Using Modulation of the Spectrum of White-Light in a Michelson Interferometer," *Applied Optics*, vol. 28, pp. 3339-3342, Aug. 1989.
- Sonnenschein, C. M. et al., "Signal-To-Noise Relationships for Coaxial Systems that Heterodyne Backscatter from Atmosphere," *Applied Optics*, vol. 10, pp. 1600-1604, Jul. 1971.
- Sorin, W. V. et al., "Measurement of Rayleigh Backscattering at 1.55  $\mu\text{m}$  with 32  $\mu\text{m}$  Spatial Resolution," *IEEE Photonics Technology Letters*, vol. 4, pp. 374-376, Apr. 1992.
- Sorin, W. V. et al., "A Simple Intensity Noise-Reduction Technique for Optical Low-Coherence Reflectometry," *IEEE Photonics Technology Letters*, vol. 4, pp. 1404-1406, Dec. 1992.
- Swanson, E. A. et al., "High-Speed Optical Coherence Domain Reflectometry," *Optics Letters*, vol. 17, pp. 151-153, Jan. 1992.
- Takada, K. et al., "High-Resolution OFDR with Incorporated Fiberoptic Frequency Encoder," *IEEE Photonics Technology Letters*, vol. 4, pp. 1069-1072, Sep. 1992.
- Takada, Kazumasa et al., "Narrow-Band light Source with Acoustooptic Tunable Filter for Optical Low-Coherence Reflectometry," *IEEE Photonics Technology Letters*, vol. 8, pp. 658-660, May, 1996.
- Takada, Kazumasa et al., "New Measurement System for Fault Location in Optical Wave-Guide Devices Based on an Interometric-Technique," *Applied Optics*, vol. 26, pp. 1603-1606, May 1987.
- Tateda, Mitsuhiro et al., "Interferometric Method for Chromatic Dispersion Measurement in a Single-Mode Optical Fiber," *IEEE Journal of Quantum Electronics*, vol. 17, pp. 404-407, Mar. 1981.
- Toide, M. et al., "Two-Dimensional Coherent Detection Imaging in Multiple Scattering Media Based the Directional Resolution Capability of the Optical Heterodyne Method," *Applied Physics B (Photophysics and Laser Chemistry)*, vol. B52, pp. 391-394, 1991.
- Trutna, W. R. et al., "Continuously Tuned External-Cavity Semiconductor-Laser," *Journal of Lightwave Technology*, vol. 11, pp. 1279-1286, Aug. 1993.
- Uttam, Deepak et al., "Precision Time Domain Reflectometry in Optical Fiber Systems Using a Frequency Modulated Continuous Wave Ranging Technique," *Journal of Lightwave Technology*, vol. 3, pp. 971-977, Oct. 1985.

(56)

## References Cited

## OTHER PUBLICATIONS

- Von Der Weid, J. P. et al., "On the Characterization of Optical Fiber Network Components with Optical Frequency Domain Reflectometry," *Journal of Lightwave Technology*, vol. 15, pp. 1131-1141, Jul. 1997.
- Wysocki, P.F. et al., "Broad-Spectrum, Wavelength-Swept, Erbium-Doped Fiber Laser at 1.55-Mu-M," *Optics Letters*, vol. 15, pp. 879-881, Aug. 1990.
- Youngquist, Robert C. et al., "Optical Coherence-Domain Reflectometry—A New Optical Evaluation Technique," *Optics Letters*, vol. 12, pp. 158-160, Mar. 1987.
- Yun, S. H. et al., "Wavelength-Swept Fiber Laser with Frequency Shifted Feedback and Resonantly Swept Intra-Cavity Acoustooptic Tunable Filter," *IEEE Journal of Selected Topics in Quantum Electronics*, vol. 3, pp. 1087-1096, Aug. 1997.
- Yun, S. H. et al., "Interrogation of Fiber Grating Sensor Arrays with a Wavelength-Swept Fiber Laser," *Optics Letters*, vol. 23, pp. 843-845, Jun. 1998.
- Yung, K. M., "Phase-Domain Processing of Optical Coherence Tomography Images," *Journal of Biomedical Optics*, vol. 4, pp. 125-136, Jan. 1999.
- Zhou, Xiao-Qun et al., "Extended-Range FMCW Reflectometry Using an optical Loop with a Frequency Shifter," *IEEE Photonics Technology Letters*, vol. 8, pp. 248-250, Feb. 1996.
- Zorabedian, Paul et al., "Tuning Fidelity of Acoustooptically Controlled External Cavity Semiconductor-Lasers," *Journal of Lightwave Technology*, vol. 13, pp. 62-66, Jan. 1995.
- Victor S. Y. Lin et al., "A Porous Silicon-Based Optical Interferometric Biosensor," *Science Magazine*, vol. 278, pp. 840-843, Oct. 31, 1997.
- De Boer, Johannes F. et al., "Review of Polarization Sensitive Optical Coherence Tomography and Stokes Vector Determination," *Journal of Biomedical Optics*, vol. 7, No. 3, Jul. 2002, pp. 359-371.
- Jiao, Shuliang et al., "Depth-Resolved Two-Dimensional Stokes Vectors of Backscattered Light and Mueller Matrices of Biological Tissue Measured with Optical Coherence Tomography," *Applied Optics*, vol. 39, No. 34, Dec. 1, 2000, pp. 6318-6324.
- Park, B. Hyle et al., "In Vivo Burn Depth Determination by High-Speed Fiber-Based Polarization Sensitive Optical Coherence Tomography," *Journal of Biomedical Optics*, vol. 6 No. 4, Oct. 2001, pp. 474-479.
- Roth, Jonathan E. et al., "Simplified Method for Polarization-Sensitive Optical Coherence Tomography," *Optics Letters*, vol. 26, No. 14, Jul. 15, 2001, pp. 1069-1071.
- Hitzenberger, Christopher K. et al., "Measurement and Imaging of Birefringence and Optic Axis Orientation by Phase Resolved Polarization Sensitive Optical Coherence Tomography," *Optics Express*, vol. 9, No. 13, Dec. 17, 2001, pp. 780-790.
- Wang, Xuedong et al., (2001) "Propagation of Polarized Light in Birefringent Turbid Media: Time-Resolved Simulations," Optical Imaging Laboratory, Biomedical Engineering Program, TexasAa&M University, Aug. 27, 2001, pp. 254-259.
- Wong, Brian J.F. et al., "Optical Coherence Tomography of the Rat Cochlea," *Journal of Biomedical Optics*, vol. 5, No. 4, Oct. 2000, pp. 367-370.
- Yao, Gang et al., "Propagation of Polarized Light in Turbid Media: Simulated Animation Sequences," *Optics Express*, vol. 7, No. 5, Aug. 28, 2000, pp. 198-203.
- Wang, Xiao-Jun et al., "Characterization of Dentin and Enamel by Use of Optical Coherence Tomography," *Applied Optics*, vol. 38, No. 10, Apr. 1, 1999, pp. 2092-2096.
- De Boer, Johannes F. et al., "Determination of the Depth-Resolved Stokes Parameters of Light Backscattered from Turbid Media by use of Polarization-Sensitive Optical Coherence Tomography," *Optics Letters*, vol. 24, No. 5, Mar. 1, 1999, pp. 300-302.
- Ducros, Mathieu G. et al., "Polarization Sensitive Optical Coherence Tomography of the Rabbit Eye," *IEEE Journal of Selected Topics in Quantum Electronics*, vol. 5, No. 4, Jul./Aug. 1999, pp. 1159-1167.
- Groner, Warren et al., "Orthogonal Polarization Spectral Imaging: A New Method for Study of the Microcirculation," *Nature Medicine Inc.*, vol. 5 No. 10, Oct. 1999, pp. 1209-1213.
- De Boer, Johannes F. et al., "Polarization Effects in Optical Coherence Tomography of Various Viological Tissues," *IEEE Journal of Selected Topics in Quantum Electronics*, vol. 5, No. 4, Jul./Aug. 1999, pp. 1200-1204.
- Yao, Gang et al., "Two-Dimensional Depth-Resolved Mueller Matrix Characterization of Biological Tissue by Optical Coherence Tomography," *Optics Letters*, Apr. 15, 1999, vol. 24, No. 8, pp. 537-539.
- Lu, Shih-Yau et al., "Homogeneous and Inhomogeneous Jones Matrices," *J. Opt. Soc. Am. A.*, vol. 11, No. 2, Feb. 1994, pp. 766-773.
- Bickel, S. William et al., "Stokes Vectors, Mueller Matrices, and Polarized Scattered Light," *Am. J. Phys.*, vol. 53, No. 5, May 1985 pp. 468-478.
- Brehonnet, F. Le Roy et al., "Optical Media and Target Characterization by Mueller Matrix Decomposition," *J. Phys. D: Appl. Phys.* 29, 1996, pp. 34-38.
- Cameron, Brent D. et al., "Measurement and Calculation of the Two-Dimensional Backscattering Mueller Matrix of a Turbid Medium," *Optics Letters*, vol. 23, No. 7, Apr. 1, 1998, pp. 485-487.
- De Boer, Johannes F. et al., "Two-Dimensional Birefringence Imaging in Biological Tissue by Polarization-Sensitive Optical Coherence Tomography," *Optics Letters*, vol. 22, No. 12, Jun. 15, 1997, pp. 934-936.
- De Boer, Johannes F. et al., "Imaging Thermally Damaged Tissue by Polarization Sensitive Optical Coherence Tomography," *Optics Express*, vol. 3, No. 6, Sep. 14, 1998, pp. 212-218.
- Everett, M.J. et al., "Birefringence Characterization of Biological Tissue by Use of Optical Coherence Tomography," *Optics Letters*, vol. 23, No. 3, Feb. 1, 1998, pp. 228-230.
- Hee, Michael R. et al., "Polarization-Sensitive Low-Coherence Reflectometer Birefringence Characterization and Ranging," *J. Opt. Soc. Am. B.*, vol. 9, No. 6, Jun. 1992, pp. 903-908.
- Barakat, Richard, "Statistics of the Stokes Parameters," *J. Opt. Soc. Am. B.*, vol. 4, No. 7, Jul. 1987, pp. 1256-1263.
- Schmitt, J.M. et al., "Cross-Polarized Backscatter in Optical Coherence Tomography of Biological Tissue," *Optics Letters*, vol. 23, No. 13, Jul. 1, 1998, pp. 1060-1062.
- Schoenberger, Klaus et al., "Mapping of Birefringence and Thermal Damage in Tissue by use of Polarization-Sensitive Optical Coherence Tomography," *Applied Optics*, vol. 37, No. 25, Sep. 1, 1998, pp. 6026-6036.
- Pierce, Mark C. et al., "Simultaneous Intensity, Birefringence, and Flow Measurements with High-Speed Fiber-Based Optical Coherence Tomography," *Optics Letters*, vol. 27, No. 17, Sep. 1, 2002, pp. 1534-1536.
- De Boer, Johannes F. et al., "Review of Polarization Sensitive Optical Coherence Tomography and Stokes Vector Determination," *Journal of Biomedical Optics*, Jul. 2002, vol. 7, No. 3, pp. 359-371.
- Fried, Daniel et al., "Imaging Caries Lesions and Lesion Progression with Polarization Sensitive Optical Coherence Tomography," *Journal of Biomedical Optics*, vol. 17, No. 4, Oct. 2002, pp. 618-627.
- Jiao, Shuliang et al., "Two-Dimensional Depth-Resolved Mueller Matrix of Biological Tissue Optics Measured with Double-Beam Polarization-Sensitive Optical Coherence Tomography," *Optics Letters*, vol. 27, No. 2, Jan. 15, 2002, pp. 101-103.
- Jiao, Shuliang et al., "Jones-Matrix Imaging of Biological Tissues with Quadruple-Channel Optical Coherence Tomography," *Journal of Biomedical Optics*, vol. 7, No. 3, Jul. 2002, pp. 350-358.
- Kuranov, R.V. et al., "Complementary Use of Cross-Polarization and Standard OCT for Differential Diagnosis of Pathological Tissues," *Optics Express*, vol. 10, No. 15, Jul. 29, 2002, pp. 707-713.
- Cense, Barry et al., "In Vivo Depth-Resolved Birefringence Measurements of the Human Retinal Nerve Fiber Layer by Polarization-Sensitive Optical Coherence Tomography," *Optics Letters*, vol. 27, No. 18, Sep. 15, 2002, pp. 1610-1612.
- Ren, Hongwu et al., "Phase-Resolved Functional Optical Coherence Tomography: Simultaneous Imaging of In Situ Tissue Structure,

(56)

## References Cited

## OTHER PUBLICATIONS

- Blood Flow Velocity, Standard Deviation, Birefringence, and Stokes Vectors in Human Skin," *Optics Letters*, vol. 27, No. 19, Oct. 1, 2002, pp. 1702-1704.
- Tripathi, Renu et al., "Spectral Shaping for Non-Gaussian Source Spectra in Optical Coherence Tomography," *Optics Letters*, vol. 27, No. 6, Mar. 15, 2002, pp. 406-408.
- Yasuno, Y. et al., "Birefringence Imaging of Human Skin by Polarization-Sensitive Spectral Interferometric Optical Coherence Tomography," *Optics Letters*, vol. 27, No. 20, Oct. 15, 2002 pp. 1803-1805.
- White, Brian R. et al., "In Vivo Dynamic Human Retinal Blood Flow Imaging Using Ultra-High-Speed Spectral Domain Optical Doppler Tomography," *Optics Express*, vol. 11, No. 25, Dec. 15, 2003, pp. 3490-3497
- De Boer, Johannes F. et al., "Improved Signal-to-Noise Ratio in Spectral-Domain Compared with Time-Domain Optical Coherence Tomography," *Optics Letters*, vol. 28, No. 21, Nov. 1, 2003, pp. 2067-2069
- Jiao, Shuliang et al., "Optical-Fiber-Based Mueller Optical Coherence Tomography," *Optics Letters*, vol. 28, No. 14, Jul. 15, 2003, pp. 1206-1208.
- Jiao, Shuliang et al., "Contrast Mechanisms in Polarization-Sensitive Mueller-Matrix Optical Coherence Tomography and Application in Burn Imaging," *Applied Optics*, vol. 42, No. 25, Sep. 1, 2003, pp. 5191-5197.
- Moreau, Julien et al., "Full-Field Birefringence Imaging by Thermal-Light Polarization-Sensitive Optical Coherence Tomography. I. Theory," *Applied Optics*, vol. 42, No. 19, Jul. 1, 2003, pp. 3800-3810.
- Moreau, Julien et al., "Full-Field Birefringence Imaging by Thermal-Light Polarization-Sensitive Optical Coherence Tomography. II. Instruments and Results," *Applied Optics*, vol. 42, No. 19, Jul. 1, 2003, pp. 3811-3818.
- Morgan, Stephen P. et al., "Surface-Reflection Elimination in Polarization Imaging of Superficial Tissue," *Optics Letters*, vol. 28, No. 2, Jan. 15, 2003, pp. 114-116.
- Oh, Jung-Taek et al., "Polarization-Sensitive Optical Coherence Tomography for Photoelasticity Testing of Glass/Epoxy Composites," *Optics Express*, vol. 11, No. 14, Jul. 14, 2003, pp. 1669-1676.
- Park, B. Hyle et al., "Real-Time Multi-Functional Optical Coherence Tomography," *Optics Express*, vol. 11, No. 7, Apr. 7, 2003, pp. 782-793.
- Shribak, Michael et al., "Techniques for Fast and Sensitive Measurements of Two-Dimensional Birefringence Distributions," *Applied Optics*, vol. 42, No. 16, Jun. 1, 2003, pp. 3009-3017.
- Somervell, A.R.D. et al., "Direct Measurement of Fringe Amplitude and Phase Using a Heterodyne Interferometer Operating in Broadband Light," *Elsevier, Optics Communications*, Oct. 2003.
- Stifter, D. et al., "Polarisation-Sensitive Optical Coherence Tomography for Material Characterisation and Strain-Field Mapping," *Applied Physics A 76, Materials Science & Processing*, Jan. 2003, pp. 947-951.
- Dave, Digant P. et al., "Polarization-Maintaining Fiber-Based Optical Low-Coherence Reflectometer for Characterization and Ranging of Birefringence," *Optics Letters*, vol. 28, No. 19, Oct. 1, 2003, pp. 1775-1777.
- Yang, Ying et al., "Observations of Birefringence in Tissues from Optic-Fibre-Based Optical Coherence Tomography," *Measurement Science and Technology*, Nov. 2002, pp. 41-46.
- Yun, S.H. et al., "High-Speed Optical Frequency-Domain Imaging," *Optics Express*, vol. 11, No. 22, Nov. 3, 2003, pp. 2953-2963
- Yun, S.H. et al., "High-Speed Spectral-Domain Optical Coherence Tomography at 1.3  $\mu\text{m}$  Wavelength," *Optics Express*, vol. 11, No. 26, Dec. 29, 2003, pp. 3598-3604.
- Zhang, Jun et al., "Determination of Birefringence and Absolute Optic Axis Orientation Using Polarization-Sensitive Optical Coherence Tomography with PM Fibers," *Optics Express*, vol. 11, No. 24, Dec. 1, 2003, pp. 3262-3270
- Pircher, Michael et al., "Three Dimensional Polarization Sensitive OCT of Human Skin In Vivo," 2004, *Optical Society of America*.
- Götzinger, Erich et al., "Measurement and Imaging of Birefringent Properties of the Human Cornea with Phase-Resolved, Polarization-Sensitive Optical Coherence Tomography," *Journal of Biomedical Optics*, vol. 9, No. 1, Jan./Feb. 2004, pp. 94-102
- Guo, Shuguang et al., "Depth-Resolved Birefringence and Differential Optical Axis Orientation Measurements with Finer-based Polarization-Sensitive Optical Coherence Tomography," *Optics Letters*, vol. 29, No. 17, Sep. 1, 2004, pp. 2025-2027.
- Huang, Xiang-Run et al., "Variation of Peripapillary Retinal Nerve Fiber Layer Birefringence in Normal Human Subjects," *Investigative Ophthalmology & Visual Science*, vol. 45, No. 9, Sep. 2004, pp. 3073-3080.
- Matcher, Stephen J. et al., "The Collagen Structure of Bovine Intervertebral Disc Studied Using Polarization-Sensitive Optical Coherence Tomography," *Physics in Medicine and Biology*, 2004, pp. 1295-1306.
- Nassif, Nader et al., "In Vivo Human Retinal Imaging by Ultrahigh-Speed Domain Optical Coherence Tomography," *Optics Letters*, vol. 29, No. 5, Mar. 1, 2004, pp. 480-482.
- Nassif, N.A. et al., "In Vivo High-Resolution Video-Rate Spectral-Domain Optical Coherence Tomography of the Human Retina and Optic Nerve," *Optics Express*, vol. 12, No. 3, Feb. 9, 2004, pp. 367-376.
- Park, B. Hyle et al., Comment on "Optical-Fiber-Based Mueller Optical Coherence Tomography," *Optics Letters*, vol. 29, No. 24, Dec. 15, 2004, pp. 2873-2874.
- Park, B. Hyle et al., "Jones Matrix Analysis for a Polarization-Sensitive Optical Coherence Tomography System Using Fiber-Optic Components," *Optics Letters*, vol. 29, No. 21, Nov. 1, 2004, pp. 2512-2514.
- Pierce, Mark C. et al., "Collagen Denaturation can be Quantified in Burned Human Skin Using Polarization-Sensitive Optical Coherence Tomography," *Elsevier, Burns*, 2004, pp. 511-517.
- Pierce, Mark C. et al., "Advances in Optical Coherence Tomography Imaging for Dermatology," *The Society for Investigative Dermatology, Inc.* 2004, pp. 458-463.
- Acioli, L. H., M. Ulman, et al. (1991). "Femtosecond Temporal Encoding in Barium-Titanate." *Optics Letters* 16(24): 1984-1986
- Aigouy, L., A. Lahrech, et al. (1999). "Polarization effects in apertureless scanning near-field optical microscopy: an experimental study," *Optics Letters* 24(4): 187-189.
- Akiba, M., K. P. Chan, et al. (2003). "Full-field optical coherence tomography by two-dimensional heterodyne detection with a pair of CCD cameras." *Optics Letters* 28(10): 816-818.
- Akkin, T., D. P. Dave, et al. (2004). "Detection of neural activity using phase-sensitive optical low-coherence reflectometry." *Optics Express* 12(11): 2377-2386.
- Akkin, T., D. P. Dave, et al. (2003). "Surface analysis using phase sensitive optical low coherence reflectometry." *Lasers in Surgery and Medicine*: 4-4.
- Akkin, T., D. P. Dave, et al. (2003). "Imaging tissue response to electrical and photothermal stimulation with nanometer sensitivity." *Lasers in Surgery and Medicine* 33(4): 219-225.
- Akkin, T., T. E. Milner, et al. (2002). "Phase-sensitive measurement of birefringence change as an indication of neural functionality and diseases." *Lasers in Surgery and Medicine*: 6-6.
- Andretzky, P., Lindner, M.W., Herrmann, J.M., Schultz, A., Konzog, M., Kiesewetter, F., Haeusler, G. (1999). "Optical coherence tomography by 'spectral radar': Dynamic range estimation and in vivo measurements of skin." *Proceedings of SPIE—The International Society for Optical Engineering* 3567: pp. 78-87.
- Antcliff, R. J., T. J. Hytche, et al. (2000). "Optical coherence tomography of melanocytoma." *American Journal of Ophthalmology* 130(6): 845-7.
- Antcliff, R. J., M. R. Stanford, et al. (2000). "Comparison between optical coherence tomography and fundus fluorescein angiography for the detection of cystoid macular edema in patients with uveitis." *Ophthalmology* 107(3): 593-9.

(56)

## References Cited

## OTHER PUBLICATIONS

- Anvari, B., T. E. Milner, et al. (1995). "Selective Cooling of Biological Tissues—Application for Thermally Mediated Therapeutic Procedures." *Physics in Medicine and Biology* 40(2): 241-252.
- Pierce, Mark C. et al., "Birefringence Measurements in Human Skin Using Polarization-Sensitive Optical Coherence Tomography," *Journal of Biomedical Optics*, vol. 9, No. 2, Mar./Apr. 2004, pp. 287-291.
- Cense, Barry et al., "In Vivo Birefringence and Thickness Measurements of the Human Retinal Nerve Fiber Layer Using Polarization-Sensitive Optical Coherence Tomography," *Journal of Biomedical Optics*, vol. 9, No. 1, Jan./Feb. 2004, pp. 121-125.
- Pircher, Michael et al., "Imaging of Polarization Properties of Human Retina in Vivo with Phase Resolved Transversal PS-OCT," *Optics Express*, vol. 12, No. 24, Nov. 29, 2004 pp. 5940-5951.
- Pircher, Michael et al., "Transversal Phase Resolved Polarization Sensitive Optical Coherence Tomography," *Physics in Medicine & Biology*, 2004, pp. 1257-1263.
- Srinivas, Shyam M. et al., "Determination of Burn Depth by Polarization-Sensitive Optical Coherence Tomography," *Journal of Biomedical Optics*, vol. 9, No. 1, Jan./Feb. 2004, pp. 207-212.
- Strasswimmer, John et al., "Polarization-Sensitive Optical Coherence Tomography of Invasive Basal Cell Carcinoma," *Journal of Biomedical Optics*, vol. 9, No. 2, Mar./Apr. 2004, pp. 292-298.
- Todorović, Miloš et al., "Determination of Local Polarization of Biological Samples in the Presence of Diattenuation by use of Mueller Optical Coherence Tomography," *Optics Letters*, vol. 29, No. 20, Oct. 15, 2004, pp. 2402-2404.
- Yasuno, Yoshiaki et al., "Polarization-Sensitive Complex Fourier Domain Optical Coherence Tomography for Jones Matrix Imaging of Biological Samples," *Applied Physics Letters*, vol. 85, No. 15, Oct. 11, 2004, pp. 3023-3025.
- Anvari, B., B. S. Tanenbaum, et al. (1995). "A Theoretical-Study of the Thermal Response of Skin to Cryogen Spray Cooling and Pulsed-Laser Irradiation—Implications for Treatment of Port-Wine Stain Birthmarks." *Physics in Medicine and Biology* 40(9): 1451-1465.
- Arend, O., M. Ruffer, et al. (2000). "Macular circulation in patients with diabetes mellitus with and without arterial hypertension." *British Journal of Ophthalmology* 84(12): 1392-1396.
- Arimoto, H. and Y. Ohtsuka (1997). "Measurements of the complex degree of spectral coherence by use of a wave-front-folded interferometer." *Optics Letters* 22(13): 958-960.
- Azzolini, C., F. Patelli, et al. (2001). "Correlation between optical coherence tomography data and biomicroscopic interpretation of idiopathic macular hole." *American Journal of Ophthalmology* 132(3): 348-55.
- Baba, T., K. Ohno-Matsui, et al. (2002). "Optical coherence tomography of choroidal neovascularization in high myopia." *Acta Ophthalmologica Scandinavica* 80(1): 82-7.
- Bail, M. A. H., Gerd; Herrmann, Juergen M.; Lindner, Michael W.; Ringler, R. (1996). "Optical coherence tomography with the "spectral radar": fast optical analysis in volume scatterers by short-coherence interferometry." *Proc. SPIE*, 2925: p. 298-303.
- Baney, D. M. and W. V. Sorin (1993). "Extended-Range Optical Low-Coherence Reflectometry Using a Recirculating Delay Technique." *Ieee Photonics Technology Letters* 5(9): 1109-1112.
- Baney, D. M., B. Szafraniec, et al. (2002). "Coherent optical spectrum analyzer." *Ieee Photonics Technology Letters* 14(3): 355-357.
- Barakat, R. (1981). "Bilinear Constraints between Elements of the 4by4 Mueller-Jones Transfer-Matrix of Polarization Theory." *Optics Communications* 38(3): 159-161.
- Barakat, R. (1993). "Analytic Proofs of the Arago-Fresnel Laws for the Interference of Polarized-Light." *Journal of the Optical Society of America a—Optics Image Science and Vision* 10(1): 180-185.
- Barbastathis, G. and D. J. Brady (1999). "Multidimensional tomographic imaging using volume holography." *Proceedings of the Ieee* 87(12): 2098-2120.
- Bardal, S., A. Kamal, et al. (1992). "Photoinduced Birefringence in Optical Fibers—a Comparative-Study of Low-Birefringence and High-Birefringence Fibers." *Optics Letters* 17(6): 411-413.
- Barsky, S. H., S. Rosen, et al. (1980). "Nature and Evolution of Port Wine Stains—Computer-Assisted Study." *Journal of Investigative Dermatology* 74(3): 154-157.
- Barton, J. K., J. A. Izatt, et al. (1999). "Three-dimensional reconstruction of blood vessels from in vivo color Doppler optical coherence tomography images." *Dermatology* 198(4): 355-361.
- Barton, J. K., A. Rollins, et al. (2001). "Photothermal coagulation of blood vessels: a comparison of high-speed optical coherence tomography and numerical modelling." *Physics in Medicine and Biology* 46.
- Barton, J. K., A. J. Welch, et al. (1998). "Investigating pulsed dye laser-blood vessel interaction with color Doppler optical coherence tomography." *Optics Express* 3.
- Bashkansky, M., M. D. Duncan, et al. (1997). "Subsurface defect detection in ceramics by high-speed high-resolution optical coherent tomography." *Optics Letters* 22 (1): 61-63.
- Bashkansky, M. and J. Reintjes (2000). "Statistics and reduction of speckle in optical coherence tomography." *Optics Letters* 25(8): 545-547.
- Baumgartner, A., S. Dichtl, et al. (2000). "Polarization-sensitive optical coherence tomography of dental structures." *Caries Research* 34(1): 59-69.
- Baumgartner, A., C. K. Hitzenberger, et al. (2000) "Resolution-improved dual-beam and standard optical coherence tomography: a comparison." *Graefes Archive for Clinical and Experimental Ophthalmology* 238(5): 385-392.
- Baumgartner, A., C. K. Hitzenberger, et al. (1998). "Signal and resolution enhancements in dual beam optical coherence tomography of the human eye." *Journal of Biomedical Optics* 3(1): 45-54.
- Beaurepaire, E., P. Gleyzes, et al. (1998). *Optical coherence microscopy for the in-depth study of biological structures. System based on a parallel detection scheme*, Proceedings of SPIE—The International Society for Optical Engineering.
- Beaurepaire, E., L. Moreaux, et al. (1999). "Combined scanning optical coherence and two-photon-excited fluorescence microscopy." *Optics Letters* 24(14): 969-971.
- Bechara, F. G., T. Gambichler, et al. (2004). "Histomorphologic correlation with routine histology and optical coherence tomography." *Skin Research and Technology* 10 (3): 169-173.
- Bechmann, M., M. J. Thiel, et al. (2000). "Central corneal thickness determined with optical coherence tomography in various types of glaucoma. [see comments]." *British Journal of Ophthalmology* 84(11): 1233-7.
- Bek, T. and M. Kandi (2000). "Quantitative anomalouscopy and optical coherence tomography scanning in central serous chorioretinopathy." *Acta Ophthalmologica Scandinavica* 78(6): 632-7.
- Benoit, A. M., K. Naoun, et al. (2001). "Linear dichroism of the retinal nerve fiber layer expressed with Mueller matrices." *Applied Optics* 40(4): 565-569.
- Bicout, D., C. Brosseau, et al. (1994). "Depolarization of Multiply Scattered Waves by Spherical Diffusers—Influence of the Size Parameter." *Physical Review E* 49(2): 1767-1770.
- Blanchot, L., M. Lebec, et al. (1997). *Low-coherence in depth microscopy for biological tissues imaging: Design of a real time control system*. Proceedings of SPIE—The International Society for Optical Engineering.
- Blumenthal, E. Z. and R. N. Weinreb (2001). "Assessment of the retinal nerve fiber layer in clinical trials of glaucoma neuroprotection. [Review] [36 refs]." *Survey of Ophthalmology* 45(Suppl 3): S305-12; discussion S332-4.
- Blumenthal, E. Z., J. M. Williams, et al. (2000). "Reproducibility of nerve fiber layer thickness measurements by use of optical coherence tomography." *Ophthalmology* 107(12): 2278-82.
- Boppart, S. A., B. E. Bouma, et al. (1996). "Imaging developing neural morphology using optical coherence tomography." *Journal of Neuroscience Methods* 70.
- Boppart, S. A., B. E. Bouma, et al. (1997). "Forward-imaging instruments for optical coherence tomography." *Optics Letters* 22.

(56)

## References Cited

## OTHER PUBLICATIONS

- Boppart, S. A., B. E. Bouma, et al. (1998). "Intraoperative assessment of microsurgery with three-dimensional optical coherence tomography." *Radiology* 208: 81-86.
- Boppart, S. A., J. Herrmann, et al. (1999). "High-resolution optical coherence tomography-guided laser ablation of surgical tissue." *Journal of Surgical Research* 82(2): 275-84.
- Bouma, B. E. and J. G. Fujimoto (1996). "Compact Kerr-lens mode-locked resonators." *Optics Letters* 21: 134-136.
- Bouma, B. E., L. E. Nelson, et al. (1998). "Optical coherence tomographic imaging of human tissue at 1.55  $\mu\text{m}$  and 1.81  $\mu\text{m}$  using Er and Tm-doped fiber sources." *Journal of Biomedical Optics* 3: 76-79.
- Bouma, B. E., M. Ramaswamy-Paye, et al. (1997). "Compact resonator designs for mode-locked solid-state lasers." *Applied Physics B (Lasers and Optics)* B65: 213-220.
- Bouma, B. E. and G. J. Tearney (2002). "Clinical imaging with optical coherence tomography." *Academic Radiology* 9(8): 942-953.
- Bouma, B. E., G. J. Tearney, et al. (1996). "Self-phase-modulated Kerr-lens mode-locked Cr:forsterite laser source for optical coherence tomography." *Optics Letters* 21(22): 1839.
- Bouma, B. E., G. J. Tearney, et al. (2000). "High-resolution imaging of the human esophagus and stomach in vivo using optical coherence tomography." *Gastrointestinal Endoscopy* 51(4): 467-474.
- Bouma, B. E., G. J. Tearney, et al. (2003). "Evaluation of intracoronary stenting by intravascular optical coherence tomography." *Heart* 89(3): 317-320.
- Bourquin, S., V. Monterosso, et al. (2000). "Video-rate optical low-coherence reflectometry based on a linear smart detector array." *Optics Letters* 25(2): 102-104.
- Bourquin, S., P. Seitz, et al. (2001). "Optical coherence topography based on a two-dimensional smart detector array." *Optics Letters* 26(8): 512-514.
- Bouzd, A., M. A. G. Abushagur, et al. (1995). "Fiber-optic four-detector polarimeter." *Optics Communications* 118(3-4): 329-334.
- Bowd, C., R. N. Weinreb, et al. (2000). "The retinal nerve fiber layer thickness in ocular hypertensive, normal, and glaucomatous eyes with optical coherence tomography." *Archives of Ophthalmology* 118(1): 22-6.
- Bowd, C., L. M. Zangwill, et al. (2001). "Detecting early glaucoma by assessment of retinal nerve fiber layer thickness and visual function." *Investigative Ophthalmology & Visual Science* 42(9): 1993-2003.
- Bowd, C., L. M. Zangwill, et al. (2002). "Imaging of the optic disc and retinal nerve fiber layer: the effects of age, optic disc area, refractive error, and gender." *Journal of the Optical Society of America, A, Optics, Image Science, & Vision* 19(1): 197-207.
- Brand, S., J. M. Ponerros, et al. (2000). "Optical coherence tomography in the gastrointestinal tract." *Endoscopy* 32(10): 796-803.
- Brezinski, M. E. and J. G. Fujimoto (1999). "Optical coherence tomography: high-resolution imaging in nontransparent tissue." *IEEE Journal of Selected Topics in Quantum Electronics* 5(4): 1185-1192.
- Brezinski, M. E., G. J. Tearney, et al. (1996). "Imaging of coronary artery microstructure (in vitro) with optical coherence tomography." *American Journal of Cardiology* 77 (1): 92-93.
- Brezinski, M. E., G. J. Tearney, et al. (1996). "Optical coherence tomography for optical biopsy—Properties and demonstration of vascular pathology." *Circulation* 93(6): 1206-1213.
- Brezinski, M. E., G. J. Tearney, et al. (1997). "Assessing atherosclerotic plaque morphology: Comparison of optical coherence tomography and high frequency intravascular ultrasound." *Heart* 77(5): 397-403.
- Brink, H. B. K. and G. J. Vanblokkland (1988). "Birefringence of the Human Foveal Area Assessed In vivo with Mueller-Matrix Ellipsometry." *Journal of the Optical Society of America a—Optics Image Science and Vision* 5(1): 49-57.
- Brosseau, C. and D. Bicout (1994). "Entropy Production in Multiple-Scattering of Light by a Spatially Random Medium." *Physical Review E* 50(6): 4997-5005.
- Burgoyne, C. F., D. E. Mercante, et al. (2002). "Change detection in regional and volumetric disc parameters using longitudinal confocal scanning laser tomography." *Ophthalmology* 109(3): 455-66.
- Candido, R. and T. J. Allen (2002). "Haemodynamics in microvascular complications in type 1 diabetes." *Diabetes—Metabolism Research and Reviews* 18(4): 286-304.
- Cense, B., T. C. Chen, et al. (2004). "Thickness and birefringence of healthy retinal nerve fiber layer tissue measured with polarization-sensitive optical coherence tomography." *Investigative Ophthalmology & Visual Science* 45(8): 2606-2612.
- Cense, B., N. Nassif, et al. (2004). "Ultrahigh-Resolution High-Speed Retinal Imaging Using Spectral-Domain Optical Coherence Tomography." *Optics Express* 12(11): 2435-2447.
- Chance, B., J. S. Leigh, et al. (1988). "Comparison of Time-Resolved and Time-Unresolved Measurements of Deoxyhemoglobin in Brain." *Proceedings of the National Academy of Sciences of the United States of America* 85(14): 4971-4975.
- Chang, E. P., D. A. Keedy, et al. (1974). "Ultrastructures of Rabbit Corneal Stroma—Mapping of Optical and Morphological Anisotropies." *Biochimica Et Biophysica Acta* 343(3): 615-626.
- Chartier, T., A. Hideur, et al. (2001). "Measurement of the elliptical birefringence of single-mode optical fibers." *Applied Optics* 40(30): 5343-5353.
- Chauhan, B. C., J. W. Blanchard, et al. (2000). "Technique for Detecting Serial Topographic Changes in the Optic Disc and Peripapillary Retina Using Scanning Laser Tomograph." *Invest Ophthalmol Vis Sci* 41: 775-782.
- Chen, Z. P., T. E. Milner, et al. (1997). "Optical Doppler tomographic imaging of fluid flow velocity in highly scattering media." *Optics Letters* 22(1): 64-66.
- Chen, Z. P., T. E. Milner, et al. (1997). "Noninvasive imaging of in vivo blood flow velocity using optical Doppler tomography." *Optics Letters* 22(14): 1119-1121.
- Chen, Z. P., Y. H. Zhao, et al. (1999). "Optical Doppler tomography." *Ieee Journal of Selected Topics in Quantum Electronics* 5(4): 1134-1142.
- Cheong, W. F., S. A. Prael, et al. (1990). "A Review of the Optical-Properties of Biological Tissues." *Ieee Journal of Quantum Electronics* 26(12): 2166-2185.
- Chernikov, S. V., Y. Zhu, et al. (1997). "Supercontinuum self-Q-switched ytterbium fiber laser." *Optics Letters* 22(5): 298-300.
- Cho, S. H., B. E. Bouma, et al. (1999). "Low-repetition-rate high-peak-power Kerr-lens mode-locked Ti:Al/sub 2/0/sub 3/ laser with a multiple-pass cavity." *Optics Letters* 24(6): 417-419.
- Choma, M. A., M. V. Sarunic, et al. (2003). "Sensitivity advantage of swept source and Fourier domain optical coherence tomography." *Optics Express* 11(18): 2183-2189.
- Choma, M. A., C. H. Yang, et al. (2003). "Instantaneous quadrature low-coherence interferometry with 3x3 fiber-optic couplers." *Optics Letters* 28(22): 2162-2164.
- Choplin, N. T. and D. C. Lundy (2001). "The sensitivity and specificity of scanning laser polarimetry in the detection of glaucoma in a clinical setting." *Ophthalmology* 108 (5): 899-904.
- Christens Barry, W. A., W. J. Green, et al. (1996). "Spatial mapping of polarized light transmission in the central rabbit cornea." *Experimental Eye Research* 62(6): 651-662.
- Chvapil, M., D. P. Speer, et al. (1984). "Identification of the depth of burn injury by collagen stainability." *Plastic & Reconstructive Surgery* 73(3): 438-41.
- Cioffi, G. A. (2001). "Three common assumptions about ocular blood flow and glaucoma." *Survey of Ophthalmology* 45: S325-S331.
- Coleman, A. L. (1999). "Glaucoma." *Lancet* 354(9192): 1803-10.
- Collaborative Normal-Tension Glaucoma Study Group (1998). "Comparison of Glaucomatous Progression Between Untreated Patients With Normal Tension Glaucoma and Patients with Therapeutically Reduced Intraocular Pressures." *Am J Ophthalmol* 126: 487-97.

(56)

## References Cited

## OTHER PUBLICATIONS

- Collaborative Normal-Tension Glaucoma Study Group (1998). "The effectiveness of intraocular pressure reduction in the treatment of normal-tension glaucoma." *Am J Ophthalmol* 126: 498-505
- Collaborative Normal-Tension Glaucoma Study Group (2001). "Natural History of Normal-Tension Glaucoma." *Ophthalmology* 108: 247-253.
- Colston, B. W., M. J. Everett, et al. (1998). "Imaging of hard- and soft-tissue structure in the oral cavity by optical coherence tomography." *Applied Optics* 37(16): 3582-3585.
- Colston, B. W., U. S. Sathyam, et al. (1998). "Dental OCT." *Optics Express* 3(6): 230-238.
- Congdon, N. G., D. S. Friedman, et al. (2003). "Important causes of visual impairment in the world today." *Jama-Journal of the American Medical Association* 290(15): 2057-2060.
- Cregan, R. F., B. J. Mangan, et al. (1999). "Single-mode photonic band gap guidance of light in air." *Science* 285(5433): 1537-1539.
- DalMolin, M., A. Galtarossa, et al. (1997). "Experimental investigation of linear polarization in high-birefringence single-mode fibers." *Applied Optics* 36(12): 2526-2528.
- Danielson, B. L. and C. D. Whittenberg (1987). "Guided-Wave Reflectometry with Micrometer Resolution." *Applied Optics* 26(14): 2836-2842.
- Dave, D. P. and T. E. Milner (2000). "Doppler-angle measurement in highly scattering media." *Optics Letters* 25(20): 1523-1525.
- de Boer, J. F., T. E. Milner, et al. (1998). *Two dimensional birefringence imaging in biological tissue using phase and polarization sensitive optical coherence tomography*. Trends in Optics and Photonics (TOPS): Advances in Optical Imaging and Photon Migration, Orlando, USA, Optical Society of America, Washington, DC 1998.
- de Boer, J. F., C. E. Saxer, et al. (2001). "Stable carrier generation and phase-resolved digital data processing in optical coherence tomography." *Applied Optics* 40(31): 5787-5790.
- Degroot, P. and L. Deck (1993). "3-Dimensional Imaging by Sub-Nyquist Sampling of White-Light Interferograms." *Optics Letters* 18(17): 1462-1464.
- Denk, W., J. H. Strickler, et al. (1990). "2-Photon Laser Scanning Fluorescence Microscopy." *Science* 248(4951): 73-76.
- Descour, M. R., A. H. O. Karkkainen, et al. (2002). "Toward the development of miniaturized Imaging systems for detection of pre-cancer." *Ieee Journal of Quantum Electronics* 38(2): 122-130.
- Detwiller, L. (1997). "Polarization state interference: A general investigation." *Pure and Applied Optics* 6(1): 41-53.
- DiCarlo, C. D., W. P. Roach, et al. (1999). "Comparison of optical coherence tomography imaging of cataracts with histopathology." *Journal of Biomedical Optics* 4.
- Ding, Z., Y. Zhao, et al. (2002). "Real-time phase-resolved optical tomography and coherence optical Doppler tomography." *Optics Express* 10(5): 236-245.
- Dobrin, P. B. (1996). "Effect of histologic preparation on the cross-sectional area of arterial rings." *Journal of Surgical Research* 61(2): 413-5.
- Donohue, D. J., B. J. Stoyanov, et al. (1995). "Numerical Modeling of the Corneal Lamellar Structure and Birefringence Properties." *Journal of the Optical Society of America a—Optics Image Science and Vision* 12(7): 1425-1439.
- Doornbos, R. M. P., R. Lang, et al. (1999). "The determination of in vivo human tissue optical properties and absolute chromophore concentrations using spatially resolved steady-state diffuse reflectance spectroscopy." *Physics in Medicine and Biology* 44(4): 967-981.
- Drexler, W., A. Baumgartner, et al. (1997). "Biometric investigation of changes in the anterior eye segment during accommodation." *Vision Research* 37(19): 2789-2800.
- Drexler, W., A. Baumgartner, et al. (1997). "Submicrometer precision biometry of the anterior segment of the human eye." *Investigative Ophthalmology & Visual Science* 38(7): 1304-1313.
- Drexler, W., A. Baumgartner, et al. (1998). "Dual beam optical coherence tomography: signal identification for ophthalmologic diagnosis." *Journal of Biomedical Optics* 3 (1): 55-65.
- Drexler, W., O. Findl, et al. (1998). "Partial coherence interferometry: A novel approach to biometry in cataract surgery." *American Journal of Ophthalmology* 126(4): 524-534.
- Drexler, W., O. Findl, et al. (1997). "Clinical feasibility of dual beam optical coherence topography and tomography for ophthalmologic diagnosis." *Investigative Ophthalmology & Visual Science* 38(4): 1038-1038.
- Drexler, W., C. K. Hitzenberger, et al. (1998). "Investigation of dispersion effects in ocular media by multiple wavelength partial coherence interferometry." *Experimental Eye Research* 66(1): 25-33.
- Drexler, W., C. K. Hitzenberger, et al. (1996). "(Sub)micrometer precision biometry of the human eye by optical coherence tomography and topography." *Investigative Ophthalmology & Visual Science* 37(3): 4374-4374.
- Drexler, W., C. K. Hitzenberger, et al. (1995). "Measurement of the Thickness of Fundus Layers by Partial Coherence Tomography." *Optical Engineering* 34(3): 701-710.
- Drexler, W., U. Morgner, et al. (2001). "Ultrahigh-resolution ophthalmic optical coherence tomography." *Nature Medicine* 7(4): 502-507.
- Drexler, W., U. Morgner, et al. (2001). "Ultrahigh-resolution ophthalmic optical coherence tomography. [erratum appears in Nat Med May 2001;7(5):636.]" *Nature Medicine* 7(4): 502-7.
- Drexler, W., H. Sattmann, et al. (2003). "Enhanced visualization of macular pathology with the use of ultrahigh-resolution optical coherence tomography." *Archives of Ophthalmology* 121(5): 695-706.
- Drexler, W., D. Stamper, et al. (2001). "Correlation of collagen organization with polarization sensitive imaging of in vitro cartilage: implications for osteoarthritis." *Journal of Rheumatology* 28(6): 1311-8.
- Droog, E. J., W. Steenberg, et al. (2001). "Measurement of depth of burns by laser Doppler perfusion imaging." *Burns* 27(6): 561-8.
- Dubois, A., K. Grieve, et al. (2004). "Ultrahigh-resolution full-field optical coherence tomography." *Applied Optics* 43(14): 2874-2883.
- Dubois, A., L. Vabre, et al. (2002). "High-resolution full-field optical coherence tomography with a Linnik microscope." *Applied Optics* 41(4): 805-812.
- Ducros, M., M. Laubscher, et al. (2002). "Parallel optical coherence tomography in scattering samples using a two-dimensional smart-pixel detector array." *Optics Communications* 202(1-3): 29-35.
- Ducros, M. G., J. D. Marsack, et al. (2001). "Primate retina imaging with polarization-sensitive optical coherence tomography." *Journal of the Optical Society of America a—Optics Image Science and Vision* 18(12): 2945-2956.
- Duncan, A., J. H. Meek, et al. (1995). "Optical Pathlength Measurements on Adult Head, Calf and Forearm and the Head of the Newborn-Infant Using Phase-Resolved Optical Spectroscopy." *Physics in Medicine and Biology* 40(2): 295-304.
- Eigensee, A., G. Haeusler, et al. (1996). "New method of short-coherence interferometry in human skin (in vivo) and in solid volume scatterers." *Proceedings of SPIE—The International Society for Optical Engineering* 2925: 169-178.
- Eisenbeiss, W., J. Marotz, et al. (1999). "Reflection-optical multispectral imaging method for objective determination of burn depth." *Burns* 25(8): 697-704.
- Elbaum, M., M. King, et al. (1972). "Wavelength-Diversity Technique for Reduction of Speckle Size." *Journal of the Optical Society of America* 62(5): 732-&.
- Ervin, J. C., H. G. Lemij, et al. (2002). "Clinician change detection viewing longitudinal stereophotographs compared to confocal scanning laser tomography in the LSU Experimental Glaucoma (LEG) Study." *Ophthalmology* 109(3): 467-81.
- Essenpreis, M., C. E. Elwell, et al. (1993). "Spectral Dependence of Temporal Point Spread Functions in Human Tissues." *Applied Optics* 32(4): 418-425.
- Eun, H. C. (1995). "Evaluation of skin blood flow by laser Doppler flowmetry. [Review] [151 refs]." *Clinics in Dermatology* 13(4): 337-47.

(56)

## References Cited

## OTHER PUBLICATIONS

- Evans, J. A., J. M. Poneris, et al. (2004). "Application of a histopathologic scoring system to optical coherence tomography (OCT) images to identify high-grade dysplasia in Barrett's esophagus." *Gastroenterology* 126(4): A51-A51.
- Feldchtein, F. I., G. V. Gelikonov, et al. (1998). "In vivo OCT imaging of hard and soft tissue of the oral cavity." *Optics Express* 3(6): 239-250. (1998).
- Feldchtein, F. I., G. V. Gelikonov, et al. (1998). "Endoscopic applications of optical coherence tomography." *Optics Express* 3(6): 257-270.
- Fercher, A. F., W. Drexler, et al. (1997). "Optical ocular tomography." *Neuro-Ophthalmology* 18(2): 39-49.
- Fercher, A. F., W. Drexler, et al. (1994). *Measurement of optical distances by optical spectrum modulation*. Proceedings of SPIE—The International Society for Optical Engineering.
- Fercher, A. F., W. Drexler, et al. (2003). "Optical coherence tomography—principles and applications." *Reports on Progress in Physics* 66(2): 239-303.
- Fercher, A. F., C. Hitzenberger, et al. (1991). "Measurement of Intraocular Optical Distances Using Partially Coherent Laser-Light." *Journal of Modern Optics* 38(7): 1327-1333.
- Fercher, A. F., C. K. Hitzenberger, et al. (1996). *Ocular partial coherence interferometry*. Proceedings of SPIE—The International Society for Optical Engineering.
- Fercher, A. F., C. K. Hitzenberger, et al. (1993). "In-Vivo Optical Coherence Tomography." *American Journal of Ophthalmology* 116(1): 113-115.
- Fercher, A. F., C. K. Hitzenberger, et al. (1994). *In-vivo dual-beam optical coherence tomography*. Proceedings of SPIE—The International Society for Optical Engineering.
- Fercher, A. F., C. K. Hitzenberger, et al. (1995). "Measurement of Intraocular Distances by Backscattering Spectral Interferometry." *Optics Communications* 117(1-2): 43-48.
- Fercher, A. F., C. K. Hitzenberger, et al. (2000). "A thermal light source technique for optical coherence tomography." *Optics Communications* 185(1-3): 57-64.
- Fercher, A. F., C. K. Hitzenberger, et al. (2001). "Numerical dispersion compensation for Partial Coherence Coherence Interferometry and Optical Tomography." *Optics Express* 9(12): 610-615.
- Fercher, A. F., C. K. Hitzenberger, et al. (2002). "Dispersion compensation for optical coherence tomography depth-scan signals by a numerical technique." *Optics Communications* 204(1-6): 67-74.
- Fercher, A. F., H. C. Li, et al. (1993). "Slit Lamp Laser-Doppler Interferometer." *Lasers in Surgery and Medicine* 13(4): 447-452.
- Fercher, A. F., K. Mengedoh, et al. (1988). "Eye-Length Measurement by Interferometry with Partially Coherent-Light." *Optics Letters* 13(3): 186-188.
- Ferro, P., M. Haelterman, et al. (1991). "All-Optical Polarization Switch with Long Low-Birefringence Fiber." *Electronics Letters* 27(16): 1407-1408.
- Fetterman, M. R., D. Goswami, et al. (1998). "Ultrafast pulse shaping: amplification and characterization." *Optics Express* 3(10):366-375.
- Findl, O., W. Drexler, et al. (2001). "Improved prediction of intraocular lens power using partial coherence interferometry." *Journal of Cataract and Refractive Surgery* 27 (6): 861-867.
- Fork, R. L., C. H. B. Cruz, et al. (1987). "Compression of Optical Pulses to Femtoseconds by Using Cubic Phase Compensation." *Optics Letters* 12(7): 483-485.
- Foschini, G. J. and C. D. Poole (1991). "Statistical-Theory of Polarization Dispersion in Single-Mode Fibers." *Journal of Light-wave Technology* 9(11): 1439-1456.
- Francia, C., F. Bruyere, et al. (1998). "PMD second-order effects on pulse propagation in single-mode optical fibers." *Ieee Photonics Technology Letters* 10(12): 1739-1741
- Fried, D., R. E. Glena, et al. (1995). "Nature of Light-Scattering in Dental Enamel and Dentin at Visible and near-Infrared Wavelengths." *Applied Optics* 34(7): 1278-1285.
- Fujimoto, J. G., M. E. Brezinski, et al. (1995). "Optical Biopsy and Imaging Using Optical Coherence Tomography." *Nature Medicine* 1(9): 970-972.
- Fukasawa, A. and H. Iijima (2002). "Optical coherence tomography of choroidal osteoma." *American Journal of Ophthalmology* 133(3): 419-21.
- Fymat, A. L. (1981). "High-Resolution Interferometric Spectrophotopolarimetry." *Optical Engineering* 20(1): 25-30.
- Galtarossa, A., L. Palmieri, et al. (2000). "Statistical characterization of fiber random birefringence." *Optics Letters* 25(18): 1322-1324.
- Galtarossa, A., L. Palmieri, et al. (2000). "Measurements of beat length and perturbation length in long single-mode fibers." *Optics Letters* 25(6): 384-386.
- Gandjbakhche, A. H., P. Mills, et al. (1994). "Light-Scattering Technique for the Study of Orientation and Deformation of Red-Blood-Cells in a Concentrated Suspension." *Applied Optics* 33(6): 1070-1078.
- Garcia, N. and M. Nieto-Vesperinas (2002). "Left-handed materials do not make a perfect lens." *Physical Review Letters* 88(20).
- Gelikonov, V. M., G. V. Gelikonov, et al. (1995). "Coherent Optical Tomography of Microscopic Inhomogeneities in Biological Tissues." *Jetp Letters* 61(2): 158-162.
- George, N. and A. Jain (1973). "Speckle Reduction Using Multiple Tones of Illumination." *Applied Optics* 12(6): 1202-1212.
- Gibson, G. N., R. Klank, et al. (1996). "Electro-optically cavity-dumped ultrashort-pulse Ti:sapphire oscillator." *Optics Letters* 21(14): 1055.
- Gil, J. J. (2000). "Characteristic properties of Mueller matrices." *Journal of the Optical Society of Vision America a—Optics Image Science and Vision* 17(2): 328-334.
- Gil, J. J. and E. Bernabeu (1987). "Obtainment of the Polarizing and Retardation Parameters of a Nondepolarizing Optical-System from the Polar Decomposition of Its Mueller Matrix." *Optik* 76(2): 67-71.
- Gladkova, N. D., G. A. Petrova, et al. (2000). "In vivo optical coherence tomography imaging of human skin: norm and pathology." *Skin Research and Technology* 6 (1): 6-16.
- Glaessl, A., A. G. Schreyer, et al. (2001). "Laser surgical planning with magnetic resonance imaging-based 3-dimensional reconstructions for intralesional Nd : YAG laser therapy of a venous malformation of the neck." *Archives of Dermatology* 137(10): 1331-1335.
- Gloesmann, M., B. Hermann, et al. (2003). "Histologic correlation of pig retina radial stratification with ultrahigh-resolution optical coherence tomography." *Investigative Ophthalmology & Visual Science* 44(4): 1696-1703.
- Goldberg, L. and D. Mehuys (1994). "High-Power Superluminescent Diode Source." *Electronics Letters* 30(20): 1682-1684.
- Goldsmith, J. A., Y. Li, et al. (2005). "Anterior chamber width measurement by high speed optical coherence tomography." *Ophthalmology* 112(2): 238-244.
- Goldstein, L. E., J. A. Muffat, et al. (2003). "Cytosolic beta-amyloid deposition and supranuclear cataracts in lenses from people with Alzheimer's disease." *Lancet* 361(9365): 1258-1265.
- Golubovic, B., B. E. Bouma, et al. (1996). "Thin crystal, room-temperature Cr/sup 4 +/:forstefite laser using near-infrared pumping." *Optics Letters* 21(24): 1993-1995.
- Gonzalez, S. and Z. Tannous (2002). "Real-time, in vivo confocal reflectance microscopy of basal cell carcinoma." *Journal of the American Academy of Dermatology* 47(6):869-874
- Gordon, M. O. and M. A. Kass (1999). "The Ocular Hypertension Treatment Study: design and baseline description of the participants." *Archives of Ophthalmology* 117(5): 573-83.
- Grayson, T. P., J. R. Torgerson, et al. (1994). "Observation of a Nonlocal Pancharatnam Phase-Shift in the Process of Induced Coherence without Induced Emission." *Physical Review A* 49(1): 626-628.
- Greaney, M. J., D. C. Hoffman, et al. (2002). "Comparison of optic nerve imaging methods to distinguish normal eyes from those with glaucoma." *Investigative Ophthalmology & Visual Science* 43(1): 140-5.

(56)

## References Cited

## OTHER PUBLICATIONS

- Greenfield, D. S., H. Bagga, et al. (2003). "Macular thickness changes in glaucomatous optic neuropathy detected using optical coherence tomography." *Archives of Ophthalmology* 121(1): 41-46.
- Greenfield, D. S., R. W. Knighton, et al. (2000). "Effect of corneal polarization axis on assessment of retinal nerve fiber layer thickness by scanning laser polarimetry." *American Journal of Ophthalmology* 129(6): 715-722.
- Griffin, R. A., D. D. Sampson, et al. (1995). "Coherence Coding for Photonic Code-Division Multiple-Access Networks." *Journal of Lightwave Technology* 13(9): 1826-1837.
- Guedes, V., J. S. Schuman, et al. (2003). "Optical coherence tomography measurement of macular and nerve fiber layer thickness in normal and glaucomatous human eyes." *Ophthalmology* 110(1): 177-189.
- Gueugniard, P. Y., H. Carsin, et al. (2000). "Current advances in the initial management of major thermal burns. [Review] [76 refs]." *Intensive Care Medicine* 26(7): 848-56.
- Guido, S. and R. T. Tranquillo (1993). "A Methodology for the Systematic and Quantitative Study of Cell Contact Guidance in Oriented Collagen Gels—Correlation of Fibroblast Orientation and Gel Birefringence." *Journal of Cell Science* 105: 317-331.
- Gurses-Ozden, R., H. Ishikawa, et al. (1999). "Increasing sampling density improves reproducibility of optical coherence tomography measurements." *Journal of Glaucoma* 8(4): 238-41.
- Guzzi, R. (1998). "Scattering Theory from Homogeneous and Coated Spheres." 1-11.
- Haberland, U. B., Vladimir; Schmitt, Hans J. (1996). "Optical coherent tomography of scattering media using electrically tunable near-infrared semiconductor laser." *Applied Optics* Draft Copy.
- Haberland, U. R., Walter; Blazek, Vladimir; Schmitt, Hans J. (1995). "Investigation of highly scattering media using near-infrared continuous wave tunable semiconductor laser." *Proc. SPIE* , 2389: 503-512.
- Hale, G. M. and M. R. Querry (1973). "Optical-Constants of Water in 200-Nm to 200-Mum Wavelength Region." *Applied Optics* 12(3): 555-563.
- Hammer, D. X., R. D. Ferguson, et al. (2002). "Image stabilization for scanning laser ophthalmoscopy." *Optics Express* 10(26): 1542.
- Hara, T., Y. Ooi, et al. (1989). "Transfer Characteristics of the Microchannel Spatial Light-Modulator." *Applied Optics* 28(22): 4781-4786.
- Harland, C. C., S. G. Kale, et al. (2000). "Differentiation of common benign pigmented skin lesions from melanoma by high-resolution ultrasound." *British Journal of Dermatology* 143(2): 281-289.
- Hartl, I., X. D. Li, et al. (2001). "Ultra-high-resolution optical coherence tomography using continuum generation in an air-silica microstructure optical fiber." *Optics Letters* 26(9): 608-610.
- Hassenstein, A., A. A. Bialasiewicz, et al. (2000). "Optical coherence tomography in uveitis patients." *American Journal of Ophthalmology* 130(5): 669-70.
- Hattenhauer, M. G., D. H. Johnson, et al. (1998). "The probability of blindness from open-angle glaucoma. [see comments]." *Ophthalmology* 105(11): 2099-104.
- Hausler, G., J. M. Herrmann, et al. (1996). "Observation of light propagation in volume scatterers with 10(11)-fold slow motion." *Optics Letters* 21(14): 1087-1089.
- Hazebroek, H. F. and A. A. Holscher (1973). "Interferometric Ellipsometry." *Journal of Physics E—Scientific Instruments* 6(9): 822-826.
- Hazebroek, H. F. and W. M. Visser (1983). "Automated Laser Interferometric Ellipsometry and Precision Reflectometry." *Journal of Physics E—Scientific Instruments* 16(7): 654-661.
- He, Z. Y., N. Mukohzaka, et al. (1997). "Selective image extraction by synthesis of the coherence function using two-dimensional optical lock-in amplifier with microchannel spatial light modulator." *Ieee Photonics Technology Letters* 9(4): 514-516.
- Hee, M. R., J. A. Izatt, et al. (1993). "Femtosecond Transillumination Optical Coherence Tomography." *Optics Letters* 18(12): 950-952.
- Hee, M. R., J. A. Izatt, et al. (1995). "Optical coherence tomography of the human retina." *Archives of Ophthalmology* 113(3): 325-32.
- Hee, M. R., C. A. Puliafito, et al. (1998). "Topography of diabetic macular edema with optical coherence tomography." *Ophthalmology* 105(2): 360-70.
- Hee, M. R., C. A. Puliafito, et al. (1995). "Quantitative assessment of macular edema with optical coherence tomography." *Archives of Ophthalmology* 113(8): 1019-29.
- Hellmuth, T. and M. Welle (1998). "Simultaneous measurement of dispersion, spectrum, and distance with a fourier transform spectrometer." *Journal of Biomedical Optics* 3(1): 7-11.
- Hemenger, R. P. (1989). "Birefringence of a medium of tenuous parallel cylinders." *Applied Optics* 28(18): 4030-4034.
- Henry, M. (1981). "Fresnel-Arago Laws for Interference in Polarized-Light—Demonstration Experiment." *American Journal of Physics* 49(7): 690-691.
- Herz, P. R., Y. Chen, et al. (2004). "Micromotor endoscope catheter for in vivo, ultrahigh-resolution optical coherence tomography." *Optics Letters* 29(19): 2261-2263.
- Hirakawa, H., H. Iijima, et al. (1999). "Optical coherence tomography of cystoid macular edema associated with retinitis pigmentosa." *American Journal of Ophthalmology* 128(2): 185-91.
- Hitzenberger, C. K., A. Baumgartner, et al. (1994). "Interferometric Measurement of Corneal Thickness with Micrometer Precision." *American Journal of Ophthalmology* 118(4): 468-476.
- Hitzenberger, C. K., A. Baumgartner, et al. (1999). "Dispersion effects in partial coherence interferometry: Implications for intraocular ranging." *Journal of Biomedical Optics* 4(1): 144-151.
- Hitzenberger, C. K., A. Baumgartner, et al. (1998). "Dispersion induced multiple signal peak splitting in partial coherence interferometry." *Optics Communications* 154 (4): 179-185.
- Hitzenberger, C. K., M. Danner, et al. (1999). "Measurement of the spatial coherence of superluminescent diodes." *Journal of Modern Optics* 46(12): 1763-1774.
- Hitzenberger, C. K. and A. F. Fercher (1999). "Differential phase contrast in optical coherence tomography." *Optics Letters* 24(9): 622-624.
- Hitzenberger, C. K., M. Sticker, et al. (2001). "Differential phase measurements in low-coherence interferometry without 2 pi ambiguity." *Optics Letters* 26(23): 1864-1866.
- Hoeling, B. M., A. D. Fernandez, et al. (2000). "An optical coherence microscope for 3-dimensional imaging in developmental biology." *Optics Express* 6(7): 136-146.
- Hoerauf, H., C. Scholz, et al. (2002). "Transscleral optical coherence tomography: a new imaging method for the anterior segment of the eye." *Archives of Ophthalmology* 120(6): 816-9.
- Hoffmann, K., M. Happe, et al. (1998). "Optical coherence tomography (OCT) in dermatology." *Journal of Investigative Dermatology* 110(4): 583-583.
- Hoh, S. T., D. S. Greenfield, et al. (2000). "Optical coherence tomography and scanning laser polarimetry in normal, ocular hypertensive, and glaucomatous eyes." *American Journal of Ophthalmology* 129(2): 129-35.
- Hohenleutner, U., M. Hilbert, et al. (1995). "Epidermal Damage and Limited Coagulation Depth with the Flashlamp-Pumped Pulsed Dye-Laser—a Histochemical-Study." *Journal of Investigative Dermatology* 104(5): 798-802.
- Holland, A. J. A., H. C. O. Martin, et al. (2002). "Laser Doppler imaging prediction of burn wound outcome in children." *Burns* 28(1): 11-17.
- Hotate, K. and T. Okugawa (1994). "Optical Information-Processing by Synthesis of the Coherence Function." *Journal of Lightwave Technology* 12(7): 1247-1255.
- Hourdakis, C. J. and A. Perris (1995). "A Monte-Carlo Estimation of Tissue Optical-Properties for Use in Laser Dosimetry." *Physics in Medicine and Biology* 40(3): 351-364.
- Hu, Z., F. Li, et al. (2000). "Wavelength-tunable narrow-linewidth semiconductor fiber-ring laser." *Ieee Photonics Technology Letters* 12(8): 977-979.
- Huang, F., W. Yang, et al. (2001). "Quadrature spectral interferometric detection and pulse shaping." *Optics Letters* 26(6): 382-384.

(56)

## References Cited

## OTHER PUBLICATIONS

- Huang, X. R. and R. W. Knighton (2002). "Linear birefringence of the retinal nerve fiber layer measured in vitro with a multispectral imaging micropolarimeter." *Journal of Biomedical Optics* 7(2): 199-204.
- Huber, R., M. Wojtkowski, et al. (2005). "Amplified, frequency swept lasers for frequency domain reflectometry and OCT imaging: design and scaling principles." *Optics Express* 13(9): 3513-3528.
- Hunter, D. G., J. C. Sandruck, et al. (1999). "Mathematical modeling of retinal birefringence scanning." *Journal of the Optical Society of America a—Optics Image Science and Vision* 16(9): 2103-2111.
- Hurwitz, H. H. and R. C. Jones (1941). "A new calculus for the treatment of optical systems II. Proof of three general equivalence theorems." *Journal of the Optical Society of America* 31(7): 493-499.
- Huttner, B., C. De Barros, et al. (1999). "Polarization-induced pulse spreading in birefringent optical fibers with zero differential group delay." *Optics Letters* 24(6): 370-372.
- Huttner, B., B. Gisin, et al. (1999). "Distributed PMD measurement with a polarization-OTDR in optical fibers." *Journal of Lightwave Technology* 17(10): 1843-1848.
- Huttner, B., J. Reecht, et al. (1998). "Local birefringence measurements in single-mode fibers with coherent optical frequency-domain reflectometry." *Ieee Photonics Technology Letters* 10(10): 1458-1460.
- Hyde, S. C. W., N. P. Barry, et al. (1995). "Sub-100-Mu-M Depth-Resolved Holographic Imaging through Scattering Media in the near-Infrared." *Optics Letters* 20(22): 2330-2332.
- Hyde, S. C. W., N. P. Barry, et al. (1995). "Depth-Resolved Holographic Imaging through Scattering Media by Photorefraction." *Optics Letters* 20(11): 1331-1333.
- Iftimia, N. V., B. E. Bouma, et al. (2004). "Adaptive ranging for optical coherence tomography." *Optics Express* 12(17): 4025-4034.
- Iida, T., N. Hagimura, et al. (2000). "Evaluation of central serous chorioretinopathy with optical coherence tomography." *American Journal of Ophthalmology* 129(1): 16-20.
- Imai, M., H. Iijima, et al. (2001). "Optical coherence tomography of tractional macular elevations in eyes with proliferative diabetic retinopathy. [republished in Am J Ophthalmol. Sep. 2001;132(3):458-61 ; 11530091.]" *American Journal of Ophthalmology* 132(1): 81-4.
- Indebetouw, G. and P. Klysubun (2000). "Imaging through scattering media with depth resolution by use of low-coherence gating in spatiotemporal digital holography." *Optics Letters* 25(4): 212-214.
- Ip, M. S., B. J. Baker, et al. (2002). "Anatomical outcomes of surgery for idiopathic macular hole as determined by optical coherence tomography." *Archives of Ophthalmology* 120(1): 29-35.
- Ismail, R., V. Tanner, et al. (2002). "Optical coherence tomography imaging of severe commotio retinae and associated macular hole." *British Journal of Ophthalmology* 86(4): 473-4.
- Izatt, J. A., M. R. Hee, et al. (1994). "Optical Coherence Microscopy in Scattering Media." *Optics Letters* 19(8): 590-592.
- Izatt, J. A., M. R. Hee, et al. (1994). "Micrometer-scale resolution imaging of the anterior eye in vivo with optical coherence tomography." *Archives of Ophthalmology* 112 (12): 1584-9.
- Izatt, J. A., M. D. Kulkarni, et al. (1997). "In vivo bidirectional color Doppler flow imaging of picoliter blood volumes using optical coherence tomography." *Optics Letters* 22(18): 1439-1441.
- Izatt, J. A., M. D. Kulkarni, et al. (1996). "Optical coherence tomography and microscopy in gastrointestinal tissues." *IEEE Journal of Selected Topics in Quantum Electronics* 2(4): 1017.
- Jacques, S. L., J. S. Nelson, et al. (1993). "Pulsed Photothermal Radiometry of Port-Wine-Stain Lesions." *Applied Optics* 32(13): 2439-2446.
- Jacques, S. L., J. R. Roman, et al. (2000). "Imaging superficial tissues with polarized light." *Lasers in Surgery and Medicine* 26(2): 119-129.
- Jang, I. K., B. E. Bouma, et al. (2002). "Visualization of coronary atherosclerotic plaques in patients using optical coherence tomography: Comparison with intravascular ultrasound." *Journal of the American College of Cardiology* 39(4): 604-609.
- Jang, I. K., B. D. MacNeill, et al. (2002). "In-vivo characterization of coronary plaques in patients with ST elevation acute myocardial infarction using optical coherence tomography (OCT)." *Circulation* 106(19): 698-698 3440 Suppl. S.
- Jang, I. K., G. J. Tearney, et al. (2000). "Comparison of optical coherence tomography and intravascular ultrasound for detection of coronary plaques with large lipid-core in living patients." *Circulation* 102(18): 509-509.
- Jeng, J. C., A. Bridgeman, et al. (2003). "Laser Doppler imaging determines need for excision and grafting in advance of clinical judgment: a prospective blinded trial." *Burns* 29(7): 665-670.
- Jesser, C. A., S. A. Boppart, et al. (1999). "High resolution imaging of transitional cell carcinoma with optical coherence tomography: feasibility for the evaluation of bladder pathology." *British Journal of Radiology* 72: 1170-1176.
- Johnson, C. A., J. L. Keltner, et al. (2002). "Baseline visual field characteristics in the ocular hypertension treatment study." *Ophthalmology* 109(3): 432-7.
- Jones, R. C. (1941). "A new calculus for the treatment of optical systems III. The Sohncke theory of optical activity." *Journal of the Optical Society of America* 31 (7): 500-503.
- Jones, R. C. (1941). "A new calculus for the treatment of optical systems I. Description and discussion of the calculus." *Journal of the Optical Society of America* 31(7):488-493.
- Jones, R. C. (1942). "A new calculus for the treatment of optical systems. IV." *Journal of the Optical Society of America* 32(8): 486-493.
- Jones, R. C. (1947). "A New Calculus for the Treatment of Optical Systems .6. Experimental Determination of the Matrix." *Journal of the Optical Society of America* 37(2): 110-112.
- Jones, R. C. (1947). "A New Calculus for the Treatment of Optical Systems .5. A More General Formulation, and Description of Another Calculus." *Journal of the Optical Society of America* 37(2): 107-110.
- Jones, R. C. (1948). "A New Calculus for the Treatment of Optical Systems .7. Properties of the N-Matrices." *Journal of the Optical Society of America* 38(8): 671-685.
- Jones, R. C. (1956). "New Calculus for the Treatment of Optical Systems .8. Electromagnetic Theory." *Journal of the Optical Society of America* 46(2): 126-131.
- Jopson, R. M. The., L. E. Nelson, et al. (1999). "Measurement of second-order polarization-mode dispersion vectors in optical fibers." *Ieee Photonics Technology Letters* 11 (9): 1153-1155.
- Jost, B. M., A. V. Sergienko, et al. (1998). "Spatial correlations of spontaneously down-converted photon pairs detected with a single-photon-sensitive CCD camera." *Optics Express* 3(2): 81-88.
- Kaplan, B., E. Compain, et al. (2000). "Phase-modulated Mueller ellipsometry characterization of scattering by latex sphere suspensions." *Applied Optics* 39 (4): 629-636.
- Kass, M. A., D. K. Heuer, et al. (2002). "The Ocular Hypertension Treatment Study: a randomized trial determines that topical ocular hypotensive medication delays or prevents the onset of primary open-angle glaucoma." *Archives of Ophthalmology* 120(6): 701-13; discussion 829-30.
- Kasuga, Y., J. Arai, et al. (2000). "Optical coherence tomography to confirm early closure of macular holes." *American Journal of Ophthalmology* 130(5): 675-6.
- Kaufman, T., S. N. Lusthaus, et al. (1990). "Deep Partial Skin Thickness Burns—a Reproducible Animal-Model to Study Burn Wound-Healing." *Burns* 16(1): 13-16.
- Kemp, N. J., J. Park, et al. (2005). "High-sensitivity determination of birefringence in turbid media with enhanced polarization-sensitive optical coherence tomography." *Journal of the Optical Society of America a—Optics Image Science and Vision* 22(3): 552-560.
- Kerrigan-Baumrind, L. A., H. A. Quigley, et al. (2000). "Number of ganglion cells in glaucoma eyes compared with threshold visual field tests in the same persons." *Investigative Ophthalmology & Visual Science* 41(3): 741-8.
- Kesen, M. R., G. L. Spaeth, et al. (2002). "The Heidelberg Retina Tomograph vs clinical impression in the diagnosis of glaucoma." *American Journal of Ophthalmology* 133(5): 613-6.

(56)

## References Cited

## OTHER PUBLICATIONS

- Kienle, A. and R. Hibst (1995). "A New Optimal Wavelength for Treatment of Port-Wine Stains." *Physics in Medicine and Biology* 40(10): 1559-1576.
- Kienle, A., L. Lilge, et al. (1996). "Spatially resolved absolute diffuse reflectance measurements for noninvasive determination of the optical scattering and absorption coefficients of biological tissue." *Applied Optics* 35(13): 2304-2314.
- Kim, B. Y. and S. S. Choi (1981). "Analysis and Measurement of Birefringence in Single-Mode Fibers Using the Backscattering Method." *Optics Letters* 6(11): 578-580.
- Kimel, S., L. O. Svaasand, et al. (1994). "Differential Vascular-Response to Laser Photothermolysis." *Journal of Investigative Dermatology* 103(5): 693-700.
- Kloppenber, F. W. H., G. Beerhuizen, et al. (2001). "Perfusion of burn wounds assessed by Laser Doppler Imaging is related to burn depth and healing time." *Burns* 27(4): 359-363.
- Knighton, R. W. and X. R. Huang (2002). "Analytical methods for scanning laser polarimetry." *Optics Express* 10(21): 1179-1189.
- Knighton, R. W., X. R. Huang, et al. (2002). "Analytical model of scanning laser polarimetry for retinal nerve fiber layer assesment." *Investigative Ophthalmology & Visual Science* 43(2): 383-392.
- Knuettel, A. R. S., Joseph M.: Shay, M.; Knutson, Jay R. (1994). "Stationary low-coherence light imaging and spectroscopy using a CCD camera." *Proc. SPIE*, vol. 2135: p. 239-250.
- Knuttel, A. and M. Boehlau-Godau (2000). "Spatially confined and temporally resolved refractive index and scattering evaluation in human skin performed with optical coherence tomography." *Journal of Biomedical Optics* 5(1): 83-92.
- Knuttel, A. and J. M. Schmitt (1993). "Stationary Depth-Profiling Reflectometer Based on Low-Coherence Interferometry." *Optics Communications* 102(3-4): 193-198.
- Knuttel, A., J. M. Schmitt, et al. (1994). "Low-Coherence Reflectometry for Stationary Lateral and Depth Profiling with Acoustooptic Deflectors and a Ccd Camera." *Optics Letters* 19(4): 302-304.
- Kobayashi, M., H. Hanafusa, et al. (1991). "Polarization-Independent Interferometric Optical-Time-Domain Reflectometer." *Journal of Lightwave Technology* 9(5): 623-628.
- Kolios, M. C., M. D. Sherar, et al. (1995). "Large Blood-Vessel Cooling in Heated Tissues—a Numerical Study." *Physics in Medicine and Biology* 40(4): 477-494.
- Koozekanani, D., K. Boyer, et al. (2001). "Retinal thickness measurements from optical coherence tomography using a Markov boundary model." *Ieee Transactions on Medical Imaging* 20(9): 900-916.
- Kop, R. H. J. and R. Sprik (1995). "Phase-sensitive interferometry with ultrashort optical pulses." *Review of Scientific Instruments* 66(12): 5459-5463.
- Kramer, R. Z., J. Bella, et al. (1999). "Sequence dependent conformational variations of collagen triple-helical structure." *Nature Structural Biology* 6(5): 454-7.
- Kulkarni, M. D., T. G. van Leeuwen, et al. (1998). "Velocity-estimation accuracy and frame-rate limitations in color Doppler optical coherence tomography." *Optics Letters* 23(13): 1057-1059.
- Kwon, Y. H., C. S. Kim, et al. (2001). "Rate of visual field loss and long-term visual outcome in primary open-angle glaucoma." *American Journal of Ophthalmology* 132(1): 47-56.
- Kwong, K. F., D. Yankelevich, et al. (1993). "400-Hz Mechanical Scanning Optical Delay-Line." *Optics Letters* 18(7): 558-560.
- Landers, J., I. Goldberg, et al. (2002). "Analysis of risk factors that may be associated with progression from ocular hypertension to primary open angle glaucoma." *Clin Experiment Ophthalmology* 30(4): 242-7.
- Laszlo, A. and A. Venetianer (1998). Heat resistance in mammalian cells: Lessons and challenges *Stress of Life*. 851: 169-178.
- Laszlo, A. and A. Venetianer (1998). "Heat resistance in mammalian cells: lessons and challenges [Review] [52 refs]." *Annals of the New York Academy of Sciences* 851: 169-78.
- Laufer, J., R. Simpson, et al. (1998). "Effect of temperature on the optical properties of ex vivo human dermis and subdermis." *Physics in Medicine and Biology* 43(9): 2479-2489.
- Lederer, D. E., J. S. Schuman, et al. (2003). "Analysis of macular volume in normal and glaucomatous eyes using optical coherence tomography." *American Journal of Ophthalmology* 135(6): 838-843.
- Lee, P. P., Z. W. Feldman, et al. (2003). "Longitudinal prevalence of major eye diseases." *Archives of Ophthalmology* 121(9): 1303-1310.
- Lehrer, M. S., T. T. Sun, et al. (1998). "Strategies of epithelial repair: modulation of stem cell and transit amplifying cell proliferation." *Journal of Cell Science* 111(Pt 19): 2867-75.
- Leibowitz, H. M., D. E. Krueger, et al. (1980). "The Framingham Eye Study monograph: An ophthalmological and epidemiological study of cataract, glaucoma, diabetic retinopathy, macular degeneration, and visual acuity in a general population of 2631 adults, 1973-1975." *Survey of Ophthalmology* 24(Suppl): 335-610.
- Leitgeb, R., C. K. Hitzenberger, et al. (2003). "Performance of fourier domain vs. time domain optical coherence tomography." *Optics Express* 11(8): 889-894.
- Leitgeb, R., L. F. Schmetterer, et al. (2002). "Flow velocity measurements by frequency domain short coherence interferometry." *Proc. SPIE* 4619: 16-21.
- Leitgeb, R. A., W. Drexler, et al. (2004). "Ultra-high resolution Fourier domain optical coherence tomography." *Optics Express* 12(10): 2156-2165.
- Leitgeb, R. A., C. K. Hitzenberger, et al. (2003). "Phase-shifting algorithm to achieve high-speed long-depth-range probing by frequency-domain optical coherence tomography." *Optics Letters* 28(22): 2201-2203.
- Leitgeb, R. A., L. Schmetterer, et al. (2003). "Real-time assessment of retinal blood flow with Optics ultrafast acquisition by color Doppler Fourier domain optical coherence tomography." *Optics Express* 11(23): 3116-3121.
- Leitgeb, R. A., L. Schmetterer, et al. (2004). "Real-time measurement of in vitro flow by Fourier-domain color Doppler optical coherence tomography." *Optics Letters* 29 (2): 171-173.
- LeRoyBrehonnet, F. and B. LeJeune (1997). "Utilization of Mueller matrix formalism to obtain optical targets depolarization and polarization properties." *Progress in Quantum Electronics* 21(2): 109-151.
- Leske, M. C., A. M. Connell, et al. (1995). "Risk factors for open-angle glaucoma. The Barbados Eye Study. [see comments]." *Archives of Ophthalmology* 113(7): 918-24.
- Leske, M. C., A. M. Connell, et al. (2001). "Incidence of open-angle glaucoma: the Barbados Eye Studies. The Barbados Eye Studies Group. [see comments]." *Archives of Ophthalmology* 119(1): 89-95.
- Leske, M. C., A. Heijl, et al. (1999). "Early Manifest Glaucoma Trial. Design and Baseline Data." *Ophthalmology* 106(11): 2144-2153.
- Lewis, S. E., J. R. DeBoer, et al. (2005). "Sensitive, selective, and analytical improvements to a porous silicon gas sensor." *Sensors and Actuators B: Chemical* 110(1): 54-65.
- Lexer, F., C. K. Hitzenberger, et al. (1999). "Dynamic coherent focus OCT with depth-independent transversal resolution." *Journal of Modern Optics* 46(3): 541-553.
- Li, X., C. Chudoba, et al. (2000). "Imaging needle for optical coherence tomography." *Optics Letters* 25: 1520-1522.
- Li, X., T. H. Ko, et al. (2001). "Intraluminal fiber-optic Doppler imaging catheter for structural and functional optical coherence tomography." *Optics Letters* 26: 1906-1908.
- Liddington, M. I. and P. G. Shakespeare (1996). "Timing of the thermographic assessment of burns." *Burns* 22(1): 26-8.
- Lindmo, T., D. J. Smithies, et al. (1998). "Accuracy and noise in optical Doppler tomography studied by Monte Carlo simulation." *Physics in Medicine and Biology* 43(10): 3045-3064.
- Liu, J., X. Chen, et al. (1999). "New thermal wave aspects on burn evaluation of skin subjected to instantaneous heating." *IEEE Transactions on Biomedical Engineering* 46(4): 420-8.
- Luke, D. G., R. McBride, et al. (1995). "Polarization mode dispersion minimization in fiber-wound piezoelectric cylinders." *Optics Letters* 20(24): 2550-2552.

(56)

## References Cited

## OTHER PUBLICATIONS

- MacNeill, B. D., I. K. Jang, et al. (2004). "Focal and multi-focal plaque distributions in patients with macrophage acute and stable presentations of coronary artery disease." *Journal of the American College of Cardiology* 44(5): 972-979.
- Mahgerefteh, D. and C. R. Menyuk (1999). "Effect of first-order PMD compensation on the statistics of pulse broadening in a fiber with randomly varying birefringence." *Ieee Photonics Technology Letters* 11(3): 340-342.
- Maitland, D. J. and J. T. Walsh, Jr. (1997). "Quantitative measurements of linear birefringence during heating of native collagen." *Lasers in Surgery & Medicine* 20 (3): 310-8.
- Majaron, B., S. M. Srinivas, et al. (2000). "Deep coagulation of dermal collagen with repetitive Er : YAG laser irradiation." *Lasers in Surgery and Medicine* 26(2): 215-222.
- Mansuripur, M. (1991). "Effects of High-Numerical-Aperture Focusing on the State of Polarization in Optical and Magneto-optic Data-Storage Systems." *Applied Optics* 30(22): 3154-3162.
- Marshall, G. W., S. J. Marshall, et al. (1997). "The dentin substrate: structure and properties related to bonding." *Journal of Dentistry* 25(6): 441-458.
- Martin, P. (1997). "Wound healing—Aiming for perfect skin regeneration." *Science* 276 (5309): 75-81.
- Martinez, O. E. (1987). "3000 Times Grating Compressor with Positive Group-Velocity Dispersion—Application to Fiber Compensation in 1.3-1.6  $\mu$ -M Region." *Ieee Journal of Quantum Electronics* 23(1): 59-64.
- Martinez, O. E., J. P. Gordon, et al. (1984). "Negative Group-Velocity Dispersion Using Refraction." *Journal of the Optical Society of America a—Optics Image Science and Vision* 1(10): 1003-1006.
- McKinney, J. D., M. A. Webster, et al. (2000). "Characterization and imaging in optically scattering media by use of laser speckle and a variable-coherence source." *Optics Letters* 25(1): 4-6.
- Miglior, S., M. Casula, et al. (2001). "Clinical ability of Heidelberg retinal tomograph examination to detect glaucomatous visual field changes." *Ophthalmology* 108 (9): 1621-7.
- Milner, T. E., D. M. Goodman, et al. (1996). "Imaging laser heated subsurface chromophores in biological materials: Determination of lateral physical dimensions." *Physics in Medicine and Biology* 41(1): 31-44.
- Milner, T. E., D. M. Goodman, et al. (1995). "Depth Profiling of Laser-Heated Chromophores in Biological Tissues by Pulsed Photothermal Radiometry." *Journal of the Optical Society of America a—Optics Image Science and Vision* 12 (7): 1479-1488.
- Milner, T. E., D. J. Smithies, et al. (1996). "Depth determination of chromophores in human skin by pulsed photothermal radiometry." *Applied Optics* 35(19): 3379-3385.
- Mishchenko, M. I. and J. W. Hovenier (1995). "Depolarization of Light Backscattered by Randomly Oriented Nonspherical Particles." *Optics Letters* 20(12): 1356-&.
- Mistlberger, A., J. M. Liebmann, et al. (1999). "Heidelberg retina tomography and optical coherence tomography in normal, ocular-hypertensive, and glaucomatous eyes." *Ophthalmology* 106(10): 2027-32.
- Mitsui, T. (1999). "High-speed detection of ballistic photons propagating through suspensions using spectral interferometry." *Japanese Journal of Applied Physics Part 1—Regular Papers Short Notes & Review Papers* 38(5A): 2978-2982.
- Molteno, A. C., N. J. Bosma, et al. (1999). "Otago glaucoma surgery outcome study: long-term results of trabeculectomy—1976 to 1995." *Ophthalmology* 106(9): 1742-50.
- Morgner, U., W. Drexler, et al. (2000). "Spectroscopic optical coherence tomography." *Optics Letters* 25(2): 111-113.
- Morgner, U., F. X. Kartner, et al. (1999). "Sub-two-cycle pulses from a Kerr-lens mode-locked Ti : sapphire laser (vol. 24, p. 411, 1999)." *Optics Letters* 24(13): 920-920.
- Mourant, J. R., A. H. Hielscher, et al. (1998). "Evidence of intrinsic differences in the light scattering properties of tumorigenic and nontumorigenic cells." *Cancer Cytopathology* 84(6): 366-374.
- Muller, M., J. Squier, et al. (1998). "Dispersion pre-compensation of 15 femtosecond optical pulses for high-numerical-aperture objectives." *Journal of Microscopy—Oxford* 191: 141-150.
- Muscat, S., N. McKay, et al. (2002). "Repeatability and reproducibility of corneal thickness measurements by optical coherence tomography." *Investigative Ophthalmology & Visual Science* 43(6): 1791-5.
- Musch, D. C., P. R. Lichter, et al. (1999). "The Collaborative Initial Glaucoma Treatment Study. Study Design, MethodsR, and Baseline Characteristics of Enrolled Patients." *Ophthalmology* 106: 653-662.
- Neerken, S., Lucassen, G.W., Bisschop, M.A., Lenderink, E., Nuijs, T.A.M. (2004). "Characterization of age-related effects in human skin: A comparative study that applies confocal laser scanning microscopy and optical coherence tomography." *Journal of Biomedical Optics* 9(2): 274-281.
- Nelson, J. S., K. M. Kelly, et al. (2001). "Imaging blood flow in human port-wine stain in situ and in real time using optical Doppler tomography." *Archives of Dermatology* 137(6): 741-744.
- Newson, T. P., F. Farahi, et al. (1988). "Combined Interferometric and Polarimetric Fiber Optic Temperature Sensor with a Short Coherence Length Source." *Optics Communications* 68(3): 161-165.
- November, L. J. (1993). "Recovery of the Matrix Operators in the Similarity and Congruency Transformations—Applications in Polarimetry." *Journal of the Optical Society of America a—Optics Image Science and Vision* 10(4): 719-739.
- Oh, W. Y., S. H. Yun, et al. (2005). "Wide tuning range wavelength-swept laser with two semiconductor optical amplifiers." *Ieee Photonics Technology Letters* 17(3):678-680.
- Oka, K. and T. Kato (1999). "Spectroscopic polarimetry with a channeled spectrum." *Optics Letters* 24(21): 1475-1477.
- Okugawa, T. and K. Rotat (1996). "Real-time optical image processing by synthesis of the coherence function using real-time holography." *Ieee Photonics Technology Letters* 8(2): 257-259.
- Oshima, M., R. Torii, et al. (2001). "Finite element simulation of blood flow in the cerebral artery." *Computer Methods in Applied Mechanics and Engineering* 191 (6-7): 661-671.
- Pan, Y. T., H. K. Xie, et al. (2001). "Endoscopic optical coherence tomography based on a microelectromechanical mirror." *Optics Letters* 26(24): 1966-1968.
- Parisi, V., G. Manni, et al. (2001). "Correlation between optical coherence tomography, pattern electroretinogram, and visual evoked potentials in open-angle glaucoma patients." *Ophthalmology* 108(5): 905-12.
- Park, B. H., M. C. Pierce, et al. (2005). "Real-time fiber-based multi-functional spectral-domain optical coherence tomography at 1.3  $\mu$  m." *Optics Express* 13(11): 3931-3944.
- Park, D. H., J. W. Hwang, et al. (1998). "Use of laser Doppler flowmetry for estimation of the depth of burns." *Plastic and Reconstructive Surgery* 101(6): 1516-1523.
- Pendry, J. B., A. J. Holden, et al. (1999). "Magnetism from conductors and enhanced nonlinear phenomena." *Ieee Transactions on Microwave Theory and Techniques* 47(11): 2075-2084.
- Penninckx, D. and V. Morenas (1999). "Jones matrix of polarization mode dispersion." *Optics Letters* 24(13): 875-877.
- Pierce, M. C., M. Shishkov, et al. (2005). "Effects of sample arm motion in endoscopic polarization-sensitive optical coherence tomography." *Optics Express* 13(15): 5739-5749.
- Pircher, M., E. Gotzinger, et al. (2003). "Measurement and imaging of water concentration in human cornea with differential absorption optical coherence tomography." *Optics Express* 11(18): 2190-2197.
- Pircher, M., E. Gotzinger, et al. (2003). "Speckle reduction in optical coherence tomography by frequency compounding." *Journal of Biomedical Optics* 8(3): 565-569.
- Podoleanu, A. G., G. M. Dobre, et al. (1998). "En-face coherence imaging using galvanometer scanner modulation." *Optics Letters* 23(3): 147-149.
- Podoleanu, A. G. and D. A. Jackson (1999). "Noise analysis of a combined optical coherence tomograph and a confocal scanning ophthalmoscope." *Applied Optics* 38(10): 2116-2127.
- Podoleanu, A. G., J. A. Rogers, et al. (2000). "Three dimensional OCT images from retina and skin." *Optics Express* 7(9): 292-298.

(56)

## References Cited

## OTHER PUBLICATIONS

- Podoleanu, A. G., M. Seeger, et al. (1998). "Transversal and longitudinal images from the retina of the living eye using low coherence reflectometry." *Journal of Biomedical Optics* 3(1):12-20.
- Poole, C. D. (1988). "Statistical Treatment of Polarization Dispersion in Single-Mode Fiber." *Optics Letters* 13(8): 687-689.
- Povazay, B., K. Bizheva, et al. (2002). "Submicrometer axial resolution optical coherence tomography." *Optics Letters* 27(20): 1800-1802.
- Qi, B., A. P. Himmer, et al. (2004). "Dynamic focus control in high-speed optical coherence tomography based on a microelectromechanical mirror." *Optics Communications* 232(1-6): 123-128.
- Radhakrishnan, S., A. M. Rollins, et al. (2001). "Real-time optical coherence tomography of the anterior segment at 1310 nm." *Archives of Ophthalmology* 119(8): 1179-1185.
- Rogers, A. J. (1981). "Polarization-Optical Time Domain Reflectometry—a Technique for the Measurement of Field Distributions." *Applied Optics* 20(6): 1060-1074.
- Rollins, A. M. and J. A. Izatt (1999). "Optimal interferometer designs for optical coherence tomography." *Optics Letters* 24(21): 1484-1486.
- Rollins, A. M., R. Ung-arunyawee, et al. (1999). "Real-time in vivo imaging of human gastrointestinal ultrastructure by use of endoscopic optical coherence tomography with a novel efficient interferometer design." *Optics Letters* 24(19): 1358-1360.
- Rollins, A. M., S. Yazdanfar, et al. (2002). "Real-time in vivo colors Doppler optical coherence tomography." *Journal of Biomedical Optics* 7(1): 123-129.
- Rollins, A. M., S. Yazdanfar, et al. (2000). "Imaging of human retinal hemodynamics using color Doppler optical coherence tomography." *Investigative Ophthalmology & Visual Science* 41(4): S548-S548.
- Sandoz, P. (1997). "Wavelet transform as a processing tool in white-light interferometry." *Optics Letters* 22(14): 1065-1067.
- Sankaran, V., M. J. Everett, et al. (1999). "Comparison of polarized-light propagation in biological tissue and phantoms." *Optics Letters* 24(15): 1044-1046.
- Sankaran, V., J. T. Walsh, et al. (2000). "Polarized light propagation through tissue phanto, ehms containing densely packed scatterers." *Optics Letters* 25(4): 239-241.
- Sarunic, M. V., M. A. Choma, et al. (2005). "Instantaneous complex conjugate resolved spectral domain and swept-source OCT using 3x3 fiber couplers." *Optics Express* 13(3): 957-967.
- Sathyam, U. S., B. W. Colston, et al. (1999). "Evaluation of optical coherence quantitation of analytes in turbid media by use of two wavelengths." *Applied Optics* 38(10): 2097-2104.
- Schmitt, J. M. (1997). "Array detection for speckle reduction in optical coherence microscopy." *Physics in Medicine and Biology* 42(7): 1427-1439.
- Schmitt, J. M. (1999). "Optical coherence tomography (OCT): A review." *Ieee Journal of Selected Topics in Quantum Electronics* 5(4): 1205-1215.
- Schmitt, J. M. and A. Knüttel (1997). "Model of optical coherence tomography of heterogeneous tissue." *Journal of the Optical Society of America a—Optics Image Science and Vision* 14(6): 1231-1242.
- Schmitt, J. M., S. L. Lee, et al. (1997). "An optical coherence microscope with enhanced resolving power in thick tissue." *Optics Communications* 142(4-6): 203-207.
- Schmitt, J. M., S. H. Xiang, et al. (1998). "Differential absorption imaging with optical coherence tomography." *Journal of the Optical Society of America a—Optics Image Science and Vision* 15(9): 2288-2296.
- Schmitt, J. M., S. H. Xiang, et al. (1999). "Speckle in optical coherence tomography." *Journal of Biomedical Optics* 4(1): 95-105.
- Schmitt, J. M., M. J. Yadlowsky, et al. (1995). "Subsurface Imaging of Living Skin with Optical Coherence Microscopy." *Dermatology* 191(2): 93-98.
- Shi, H., J. Finlay, et al. (1997). "Multiwavelength 10-GHz picosecond pulse generation from a single-stripe semiconductor diode laser." *Ieee Photonics Technology Letters* 9(11): 1439-1441.
- Shi, H., I. Nitta, et al. (1999). "Demonstration of phase correlation in multiwavelength mode-locked semiconductor diode lasers." *Optics Letters* 24(4): 238-240.
- Simon, R. (1982). "The Connection between Mueller and Jones Matrices of Polarization Optics." *Optics Communications* 42(5): 293-297.
- Smith, P. J. M., (2000) "Variable-Focus Microlenses as a Potential Technology for Endoscopy." SPIE (vol. 3919), USA pp. 187-192.
- Smithies, D. J., T. Lindmo, et al. (1998). "Signal attenuation and localization in optical coherence tomography studied by Monte Carlo simulation." *Physics in Medicine and Biology* 43(10): 3025-3044.
- Sorin, W. V. and D. F. Gray (1992). "Simultaneous Thickness and Group Index Measurement Using Optical Low-Coherence Reflectometry." *Ieee Photonics Technology Letters* 4(1): 105-107.
- Sticker, M., C. K. Hitzenberger, et al. (2001). "Quantitative differential phase measurement and imaging in transparent and turbid media by optical coherence tomography." *Optics Letters* 26(8): 518-520.
- Sticker, M., M. Pircher, et al. (2002). "En face imaging of single cell layers by differential phase-contrast optical coherence microscopy." *Optics Letters* 27(13): 1126-1128.
- Stoller, P., B. M. Kim, et al. (2002). "Polarization-dependent optical second-harmonic imaging of a rat-tail tendon." *Journal of Biomedical Optics* 7(2): 205-214.
- Sun, C. S. (2003). "Multiplexing of fiber-optic acoustic sensors in a Michelson interferometer configuration." *Optics Letters* 28(12): 1001-1003.
- Swanson, E. A., J. A. Izatt, et al. (1993). "In-Vivo Retinal Imaging by Optical Coherence Tomography." *Optics Letters* 18(21): 1864-1866.
- Takada, K., A. Himeno, et al. (1991). "Phase-Noise and Shot-Noise Limited Operations of Low Coherence Optical-Time Domain Reflectometry." *Applied Physics Letters* 59(20): 2483-2485.
- Takenaka, H. (1973). "Unified Formalism for Polarization Optics by Using Group-Theory I (Theory)." *Japanese Journal of Applied Physics* 12(2): 226-231.
- Tanno, N., T. Ichimura, et al. (1994). "Optical Multimode Frequency-Domain Reflectometer." *Optics Letters* 19(8): 587-589.
- Tan-no, N., T. Ichimura, et al. (1994). "Optical Multimode Frequency-Domain Reflectometer." *Optics Letters* 19(8): 587-589.
- Targowski, P., M. Wojtkowski, et al. (2004). "Complex spectral OCT in human eye imaging in vivo." *Optics Communications* 229(1-6): 79-84.
- Tearney, G. J., S. A. Boppart, et al. (1996). "Scanning single-mode fiber optic catheter—endoscope for optical coherence tomography (vol. 21, p. 543, 1996)." *Optics Letters* 21(12): 912-912.
- Tearney, G. J., B. E. Bouma, et al. (1996). "Rapid acquisition of in vivo biological images by use of optical coherence tomography." *Optics Letters* 21(17): 1408-1410.
- Tearney, G. J., B. E. Bouma, et al. (1997). "In vivo endoscopic optical biopsy with optical coherence tomography." *Science* 276(5321): 2037-2039.
- Tearney, G. J., M. E. Brezinski, et al. (1996). "Catheter-based optical imaging of a human coronary artery." *Circulation* 94(11): 3013-3013.
- Tearney, G. J., M. E. Brezinski, et al. (1997). "In vivo endoscopic optical biopsy with optical coherence tomography." *Science* 276(5321): 2037-9.
- Tearney, G. J., M. E. Brezinski, et al. (1997). "Optical biopsy in human gastrointestinal tissue using optical coherence tomography." *American Journal of Gastroenterology* 92(10): 1800-1804.
- Tearney, G. J., M. E. Brezinski, et al. (1995). "Determination of the refractive index of highly scattering human tissue by optical coherence tomography." *Optics Letters* 20(21): 2258-2260.
- Tearney, G. J., I. K. Jang, et al. (2000). "Porcine coronary imaging in vivo by optical coherence tomography." *Acta Cardiologica* 55(4): 233-237.
- Tearney, G. J., R. H. Webb, et al. (1998). "Spectrally encoded confocal microscopy." *Optics Letters* 23(15): 1152-1154.

(56)

## References Cited

## OTHER PUBLICATIONS

- Tearney, G. J., H. Yabushita, et al. (2003). "Quantification of macrophage content in atherosclerotic plaques by optical coherence tomography." *Circulation* 107(1): 113-119.
- Tower, T. T. and R. T. Tranquillo (2001). "Alignment maps of tissues: I. Microscopic elliptical polarimetry." *Biophysical Journal* 81(5):2954-2963.
- Tower, T. T. and R. T. Tranquillo (2001). "Alignment maps of tissues: II. Fast harmonic analysis for imaging." *Biophysical Journal* 81(5): 2964-2971.
- Troy, T. L. and S. N. Thennadil (2001). "Optical properties of human skin in the near infrared wavelength range of 1000 to 2200 nm." *Journal of Biomedical Optics* 6 (2):167-176.
- Vabre, L., A. Dubois, et al. (2002). "Thermal-light full-field optical coherence tomography." *Optics Letters* 27(7): 530-532.
- Vakhtin, A. B., D. J. Kane, et al. (2003). "Common-path interferometer for frequency-domain optical coherence tomography." *Applied Optics* 42(34): 6953-6958.
- Vakhtin, A. B., K. A. Peterson, et al. (2003). "Differential spectral interferometry: an imaging technique for biomedical applications." *Optics Letters* 28(15): 1332-1334.
- Vakoc, B. J., S. H. Yun, et al. (2005). "Phase-resolved optical frequency domain imaging." *Optics Express* 13(14): 5483-5493.
- van Leeuwen, T. G., M. D. Kulkarni, et al. (1999). "High-flow-velocity and shear-rate imaging by use of color Doppler optical coherence tomography." *Optics Letters* 24(22): 1584-1586.
- Vansteenkiste, N., P. Vignolo, et al. (1993). "Optical Reversibility Theorems for Polarization—Application to Remote-Control of Polarization." *Journal of the Optical Society of America a—Optics Image Science and Vision* 10(10): 2240-2245.
- Vargas, O., E. K. Chan, et al. (1999). "Use of an agent to reduce scattering in skin." *Lasers in Surgery and Medicine* 24(2): 133-141.
- Wang, R. K. (1999). "Resolution improved optical coherence-gated tomography for imaging through biological tissues." *Journal of Modern Optics* 46(13): 1905-1912.
- Wang, X. J., T. E. Milner, et al. (1997). "Measurement of fluid-flow-velocity profile in turbid media by the use of optical Doppler tomography." *Applied Optics* 36(1): 144-149.
- Wang, X. J., T. E. Milner, et al. (1995). "Characterization of Fluid-Flow Velocity by Optical Doppler Tomography." *Optics Letters* 20(11): 1337-1339.
- Wang, Y. M., J. S. Nelson, et al. (2003). "Optimal wavelength for ultrahigh-resolution optical coherence tomography." *Optics Express* 11(12): 1411-1417.
- Wang, Y. M., Y. H. Zhao, et al. (2003). "Ultrahigh-resolution optical coherence tomography by broadband continuum generation from a photonic crystal fiber." *Optics Letters* 28(3): 182-184.
- Watkins, L. R., S. M. Tan, et al. (1999). "Determination of interferometer phase distributions by use of wavelets." *Optics Letters* 24(13): 905-907.
- Wetzel, J. (2001). "Optical coherence tomography in dermatology: a review." *Skin Research and Technology* 7(1): 1-9.
- Wentworth, R. H. (1989). "Theoretical Noise Performance of Coherence-Multiplexed Interferometric Sensors." *Journal of Light-wave Technology* 7(6): 941-956.
- Westphal, V., A. M. Rollins, et al. (2002). "Correction of geometric and refractive image distortions in optical coherence tomography applying Fermat's principle." *Optics Express* 10(9): 397-404.
- Westphal, V., S. Yazdanfar, et al. (2002). "Real-time, high velocity-resolution color Doppler optical coherence tomography." *Optics Letters* 27(1): 34-36.
- Williams, P. A. (1999). "Rotating-wave-plate Stokes polarimeter for differential group delay measurements of polarization-mode dispersion." *Applied Optics* 38(31): 6508-6515.
- Wojtkowski, M., T. Bajraszewski, et al. (2003). "Real-time in vivo imaging by high-speed spectral optical coherence tomography." *Optics Letters* 28(19): 1745-1747.
- Wojtkowski, M., A. Kowalczyk, et al. (2002). "Full range complex spectral optical coherence tomography technique in eye imaging." *Optics Letters* 27(16): 1415-1417.
- Wojtkowski, M., R. Leitgeb, et al. (2002). "In vivo human retinal imaging by Fourier domain optical coherence tomography." *Journal of Biomedical Optics* 7(3): 457-463.
- Wojtkowski, M., R. Leitgeb, et al. (2002). "Fourier domain OCT imaging of the human eye in vivo." *Proc. SPIE* 4619: 230-236.
- Wojtkowski, M., V. J. Srinivasan, et al. (2004). "Ultrahigh-resolution, high-speed, Fourier domain optical coherence tomography and methods for dispersion compensation." *Optics Express* 12(11): 2404-2422.
- Wong, B. J. F., Y. H. Zhao, et al. (2004). "Imaging the internal structure of the rat cochlea using optical coherence tomography at 0.827  $\mu\text{m}$  and 1.3  $\mu\text{m}$ ." *Otolaryngology—Head and Neck Surgery* 130(3): 334-338.
- Yabushita, H. B., et al. (2002). "Measurement of Thin Fibrous Caps in Atherosclerotic Plaques by Optical Coherence Tomography." American Heart Association, INC, *Circulation* 2002;106:1640.
- Yang, C., A. Wax, et al. (2001). "Phase-dispersion optical tomography." *Optics Letters* 26(10): 686-688.
- Yang, C., A. Wax, et al. (2001). "Phase-referenced interferometer with subwavelength and subhertz sensitivity applied to the study of cell membrane dynamics." *Optics Letters* 26(16): 1271-1273.
- Yang, C. H., A. Wax, et al. (2001). "Phase-dispersion optical tomography." *Optics Letters* 26(10): 686-688.
- Yang, C. H., A. Wax, et al. (2000). "Interferometric phase-dispersion microscopy." *Optics Letters* 25(20): 1526-1528.
- Yang, V. X. D., M. L. Gordon, et al. (2002). "Improved phase-resolved optical Doppler tomography using the Kasai velocity estimator and histogram segmentation." *Optics Communications* 208(4-6): 209-214.
- Yang, V. X. D., M. L. Gordon, et al. (2003). "High speed, wide velocity dynamic range Doppler optical coherence tomography (Part I): System design, signal processing, and performance." *Optics Express* 11(7): 794-809.
- Yang, V. X. D., M. L. Gordon, et al. (2003). "High speed, wide velocity dynamic range Doppler optical coherence tomography (Part II): Imaging in vivo cardiac dynamics of *Xenopus laevis*." *Optics Express* 11(14): 1650-1658.
- Yang, V. X. D., M. L. Gordon, et al. (2003). "High speed, wide velocity dynamic range Doppler optical coherence tomography (Part III): in vivo endoscopic imaging of blood flow in the rat and human gastrointestinal tracts." *Optics Express* 11(19): 2416-2424.
- Yang, V. X. D., B. Qi, et al. (2003). "In vivo feasibility of endoscopic catheter-based Doppler optical coherence tomography." *Gastroenterology* 124(4): A49-A50.
- Yao, G. and L. H. V. Wang (2000). "Theoretical and experimental studies of ultrasound-modulated optical tomography in biological tissue." *Applied Optics* 39(4): 659-664.
- Yazdanfar, S. and J. A. Izatt (2002). "Self-referenced Doppler optical coherence tomography." *Optics Letters* 27(23): 2085-2087.
- Yazdanfar, S., M. D. Kulkarni, et al. (1997). "High resolution imaging of vivo cardiac dynamics using color Doppler optical coherence tomography." *Optics Express* 1 (13) : 424-431.
- Yazdanfar, S., A. M. Rollins, et al. (2000). "Imaging and velocimetry of the human retinal circulation with color Doppler optical coherence tomography." *Optics Letters* 25(19): 1448-1450.
- Yazdanfar, S., A. M. Rollins, et al. (2000). "Noninvasive imaging and velocimetry of human retinal blood flow using color Doppler optical coherence tomography." *Investigative Ophthalmology & Visual Science* 41(4): S548-S548.
- Yazdanfar, S., A. M. Rollins, et al. (2003). "In vivo imaging of human retinal flow dynamics by color Doppler optical coherence tomography." *Archives of Ophthalmology* 121(2): 235-239.
- Yazdanfar, S., C. H. Yang, et al. (2005). "Frequency estimation precision in Doppler optical coherence tomography using the Cramer-Rao lower bound." *Optics Express* 13(2): 410-416.
- Yun, S. H., C. Boudoux, et al. (2004). "Extended-cavity semiconductor wavelength-swept laser for biomedical imaging." *Ieee Photonics Technology Letters* 16(1): 293-295.
- Yun, S. H., C. Boudoux, et al. (2003). "High-speed wavelength-swept semiconductor laser with a polygon-scanner-based wavelength filter." *Optics Letters* 28(20): 1981-1983.

(56)

## References Cited

## OTHER PUBLICATIONS

- Yun, S. H., G. J. Tearney, et al. (2004). "Pulsed-source and swept-source spectral-domain optical coherence tomography with reduced motion artifacts." *Optics Express* 12(23): 5614-5624.
- Yun, S. H., G. J. Tearney, et al. (2004). "Removing the depth-degeneracy in optical frequency domain imaging with frequency shifting." *Optics Express* 12(20): 4822-4828.
- Yun, S. H., G. J. Tearney, et al. (2004). "Motion artifacts in optical coherence tomography with frequency-domain ranging." *Optics Express* 12(13): 2977-2998.
- Zhang, J., J. S. Nelson, et al. (2005). "Removal of a mirror image and enhancement of the signal-to-noise ratio in Fourier-domain optical coherence tomography using an electro-optic phase modulator." *Optics Letters* 30(2): 147-149.
- Zhang, Y., M. Sato, et al. (2001). "Numerical investigations of optimal synthesis of several low coherence sources for resolution improvement." *Optics Communications* 192(3-6): 183-192.
- Zhang, Y., M. Sato, et al. (2001). "Resolution improvement in optical coherence tomography by optimal synthesis of light-emitting diodes." *Optics Letters* 26(4): 205-207.
- Zhao, Y., Z. Chen, et al. (2002). "Real-time phase-resolved functional optical coherence tomography by use of optical Hilbert transformation." *Optics Letters* 27(2): 98-100.
- Zhao, Y. H., Z. P. Chen, et al. (2000). "Doppler standard deviation imaging for clinical monitoring of in vivo human skin blood flow." *Optics Letters* 25(18): 1358-1360.
- Zhao, Y. H., Z. P. Chen, et al. (2000). "Phase-resolved optical coherence tomography and optical Doppler tomography for imaging blood flow in human skin with fast scanning speed and high velocity sensitivity." *Optics Letters* 25(2): 114-116.
- Zhou, D., P. R. Prucnal, et al. (1998). "A widely tunable narrow linewidth semiconductor fiber ring laser." *IEEE Photonics Technology Letters* 10(6): 781-783.
- Zuluaga, A. F. and R. Richards-Kortum (1999). "Spatially resolved spectral interferometry for determination of subsurface structure." *Optics Letters* 24(8): 519-521.
- Zvyagin, A. V., J. B. FitzGerald, et al. (2000). "Real-time detection technique for Doppler optical coherence tomography." *Optics Letters* 25(22): 1645-1647.
- Marc Nikles et al., "Brillouin gain spectrum characterization in single-mode optical fibers", *Journal of Lightwave Technology* 1997, 15 (10):1842-1851.
- Tsuyoshi Sonehara et al., "Forced Brillouin Spectroscopy Using Frequency-Tunable Continuous-Wave Lasers", *Physical Review Letters* 1995, 75 (23): 4234-4237.
- Hajime Tanaka et al., "New Method of Superheterodyne Light Beating Spectroscopy for Brillouin-Scattering Using Frequency-Tunable Lasers", *Physical Review Letters* 1995, 74 (9): 1609-1612.
- Webb RH et al. "Confocal Scanning Laser Ophthalmoscope", *Applied Optics* 1987, 26 (8): 1492-1499.
- Andreas Zumbusch et al. "Three-dimensional vibrational imaging by coherent anti-Stokes Raman scattering", *Physical Review Letters* 1999, 82 (20): 4142-4145.
- Katrin Kneipp et al., "Single molecule detection using surface-enhanced Raman scattering (SERS)", *Physical Review Letters* 1997, 78 (9): 1667-1670.
- K.J. Koski et al., "Brillouin imaging" *Applied Physics Letters* 87, 2005.
- Boas et al., "Diffusing temporal light correlation for burn diagnosis", *SPIE*, 1999, 2979:468-477.
- David J. Briers, "Speckle fluctuations and biomedical optics: implications and applications", *Optical Engineering*, 1993, 32(2):277-283.
- Clark et al., "Tracking Speckle Patterns with Optical Correlation", *SPIE* 1992, 1772:77-87.
- Clark et al., "Tracking Speckle Patterns with Optical Correlation", *SPIE*, 1992, 1772:77-87.
- Facchini et al., "An endoscopic system for DSPI", *Optik*, 1993, 95(1):27-30.
- Hrabovsky, M., "Theory of speckle displacement and decorrelation: application in mechanics", *SPIE*, 1998, 3479:345-354.
- Sean J. Kirkpatrick et al., "Micromechanical behavior of cortical bone as inferred from laser speckle data", *Journal of Biomedical Materials Research*, 1998, 39(3):373-379.
- Sean J. Kirkpatrick et al., "Laser speckle microstrain measurements in vascular tissue", *SPIE*, 1999, 3598:121-129.
- Loree et al., "Mechanical Properties of Model Atherosclerotic Lesion Lipid Pools", *Arteriosclerosis and Thrombosis*, 1994, 14(2):230-234.
- Podbielska, H. "Interferometric Methods and Biomedical Research", *SPIE*, 1999, 2732:134-141.
- Richards-Kortum et al., "Spectral diagnosis of atherosclerosis using an optical fiber laser catheter", *American Heart Journal*, 1989, 118(2):381-391.
- Ruth, B. "blood flow determination by the laser speckle method", *Int J Microcirc: Clin Exp*, 1990, 9:21-45.
- Shapo et al., "Intravascular strain imaging: Experiments on an Inhomogeneous Phantom", *IEEE Ultrasonics Symposium* 1996, 2:1177-1180.
- Shapo et al., "Ultrasonic displacement and strain imaging of coronary arteries with a catheter array", *IEEE Ultrasonics Symposium* 1995, 2:1511-1514.
- Thompson et al., "Imaging in scattering media by use of laser speckle", *Opt. Soc. Am. A.*, 1997, 14(9):2269-2277.
- Thompson et al., "Diffusive media characterization with laser speckle", *Applied Optics*, 1997, 36(16):3726-3734.
- Tuchin, Valery V., "Coherent Optical Techniques for the Analysis of Tissue Structure and Dynamics," *Journal of Biomedical Optics*, 1999, 4(1):106-124.
- M. Wussling et al., "Laser diffraction and speckling studies in skeletal and heart muscle", *Biomed, Biochim, Acta*, 1986, 45(1/2):S 23-S 27.
- T. Yoshimura et al., "Statistical properties of dynamic speckles", *J. Opt. Soc. Am A.* 1986, 3(7): 1032-1054
- Zimnyakov et al., "Spatial speckle correlometry in applications to tissue structure monitoring", *Applied Optics* 1997, 36(22): 5594-5607.
- Zimnyakov et al., "A study of statistical properties of partially developed speckle fields as applied to the diagnosis of structural changes in human skin", *Optics and Spectroscopy*, 1994, 76(5): 747-753.
- Zimnyakov et al., "Speckle patterns polarization analysis as an approach to turbid tissue structure monitoring", *SPIE* 1999, 2981:172-180.
- Ramasamy Manoharan et al., "Biochemical analysis and mapping of atherosclerotic human artery using FT-IR microspectroscopy", *Atherosclerosis*, May 1993, 181-1930.
- N. V. Salunke et al., "Biomechanics of Atherosclerotic Plaque" *Critical Reviews™ in Biomedical Engineering* 1997, 25(3):243-285.
- D. Fu et al., "Non-invasive quantitative reconstruction of tissue elasticity using an iterative forward approach", *Phys. Med. Biol.* 2000 (45): 1495-1509.
- S.B. Adams Jr. et al., "The use of polarization sensitive optical coherence tomography and elastography to assess connective tissue", *Optical Soc. of American Washington* 2002, p. 3.
- International Search Report for International Patent application No. PCT/US2005/039740 published Feb. 21, 2006.
- International Written Opinion for International Patent application No. PCT/US2005/039740 published Feb. 21, 2006.
- International Search Report for International Patent application No. PCT/US2005/030294 published Aug. 22, 2006.
- International Written Opinion for International Patent application No. PCT/US2005/043951 published Apr. 6, 2006.
- International Search Report for International Patent application No. PCT/US2005/043951 published Apr. 6, 2006.
- Erdelyi et al. "Generation of diffraction-free beams for applications in optical microlithography", *J. Vac. Sci. Technol. B* 15 (12), Mar./Apr. 1997, pp. 287-292.
- International Search Report for International Patent application No. PCT/US2005/023664 published Oct. 12, 2005.

(56)

## References Cited

## OTHER PUBLICATIONS

- International Written Opinion for International Patent application No. PCT/US2005/023664 published Oct. 12, 2005.
- Tearney et al., "Spectrally encoded miniature endoscopy" Optical Society of America; Optical Letters vol. 27, No. 6, Mar. 15, 2002; pp. 412-414.
- Yelin et al., "Double-clad Fiber for Endoscopy" Optical Society of America; Optical Letters vol. 29, No. 20, Oct. 16, 2005; pp. 2408-2410.
- International Search Report for International Patent application No. PCT/US2001/049704 published Dec. 10, 2002.
- International Search Report for International Patent application No. PCT/US2004/039454 published May 11, 2005.
- International Written Opinion for International Patent application No. PCT/US2004/039454 published May 11, 2005.
- PCT International Preliminary Report on Patentability for International Application No. PCT/US2004/038404 dated Jun. 2, 2006.
- Notice of Reasons for Rejection and English translation for Japanese Patent Application No. 2002-538830 dated May 12, 2008.
- Office Action dated Aug. 24, 2006 for U.S. Appl. No. 10/137,749.
- Barry Cense et al., "Spectral-domain polarization-sensitive optical coherence tomography at 850nm", Coherence Domain Optical Methods and Optical Coherence Tomography in Biomedicine IX, 2005, pp. 159-162.
- A. Ymeti et al., "Integration of microfluidics with a four-channel integrated optical Young interferometer immunosensor", Biosensors and Bioelectronics, Elsevier Science Publishers, 2005, pp. 1417-1421.
- PCT International Search Report for Application No. PCT/US2006/018865 filed May 5, 2006.
- International Written Opinion for International Patent application No. PCT/US2006/018865 filed May 5, 2006.
- John M. Ponerros, "Diagnosis of Barrett's esophagus using optical coherence tomography", Gastrointestinal Endoscopy clinics of North America, 14 (2004) pp. 573-588.
- P.F. Escobar et al., "Diagnostic efficacy of optical coherence tomography in the management of preinvasive and invasive cancer of uterine cervix and vulva", Int. Journal of Gynecological Cancer 2004, 14, pp. 470-474.
- Ko T et al., "Ultra-high resolution in vivo versus ex vivo OCT imaging and tissue preservation", Conference on Lasers and electro-optics, 2001, pp. 252-253.
- Paul M. Ripley et al., "A comparison of Artificial Intelligence techniques for spectral classification in the diagnosis of human pathologies based upon optical biopsy", Journal of Optical Society of America, 2000, pp. 217-219.
- Wolfgang Drexler et al., "Ultra-high-resolution optical coherence tomography", Journal of Biomedical Optics Spie USA, 2004, pp. 47-74.
- PCT International Search Report for Application No. PCT/US2006/016677 filed Apr. 28, 2006.
- International Written Opinion for International Patent application No. PCT/US2006/016677 filed Apr. 28, 2006.
- Office Action dated Nov. 13, 2006 for U.S. Appl. No. 10/501,268.
- Office Action dated Nov. 20, 2006 for U.S. Appl. No. 09/709,162.
- PCT International Search Report and Written Opinion for Application No. PCT/US2004/023585 filed Jul. 23, 2004.
- Office Action dated Dec. 6, 2006 for U.S. Appl. No. 10/997,789.
- Elliott, K. H. "The use of commercial CCD cameras as linear detectors in the physics undergraduate teaching laboratory", European Journal of Physics, 1998, pp. 107-117.
- Lauer, V. "New approach to optical diffraction tomography yielding a vector equation of diffraction tomography and a novel tomographic microscope", Journal of Microscopy vol. 205, Issue 2, 2002, pp. 165-176.
- Yu, P. et al. "Imaging of tumor necroses using full-frame optical coherence imaging", Proceedings of SPIE vol. 4956, 2003, pp. 34-41.
- Zhao, Y. et al. "Three-dimensional reconstruction of in vivo blood vessels in human skin using phase-resolved optical Doppler tomography", IEEE Journal of Selected Topics in Quantum Electronics 7.6 (2001): 931-935.
- Office Action dated Dec. 18, 2006 for U.S. Appl. No. 10/501,276.
- Devesa, Susan S. et al. (1998) "Changing Patterns in the Incidence of Esophageal and Gastric Carcinoma in the United States." *American Cancer Society* vol. 83, No. 10 pp. 2049-2053.
- Barr, H et al. (2005) "Endoscopic Therapy for Barrett's Esophagus" *Gut* vol. 54:875-884.
- Johnston, Mark H.(2005) "Technology Insight: Ablative Techniques for Barrett's Esophagus—Current and Emerging Trends" www.Nature.com/clinicalpractice/gasthep.
- Falk, Gary W. et al. (1997) "Surveillance of Patients with Barrett's Esophagus for Dysplasia and Cancer with Ballon Cytology" *Gastroenterology* vol. 112, pp. 1787-1797.
- Sepchler, Stuart Jon. (1997) "Barrett's Esophagus: Should We Brush off this Balloning Problem?" *Gastroenterology* vol. 112, pp. 2138-2152.
- Froehly, J. et al. (2003) "Multiplexed 3D Imaging Using Wavelength Encoded Spectral Interferometry: A Proof of Principle" *Optics Communications* vol. 222, pp. 127-136.
- Kubba A.K. et al. (1999) "Role of p53 Assessment in Management of Barrett's Esophagus" *Digestive Disease and Sciences* vol. 44, No. 4, pp. 659-667.
- Reid, Brian J. (2001) "p53 and Progression in Barrett's Esophagus" *The American Neoplastic Journal of Gastroenterology* vol. 96, No 5, pp. 1321-1323.
- Sharma, P. et al.(2003) "Magnification Chromoendoscopy for the Detection of Intestinal Metaplasia and Dysplasia in Barrett's Esophagus" *Gut* vol. 52, pp. 24-27.
- Kuipers E.J et al. (2005) "Diagnostic and Therapeutic Endoscopy" *Journal of Surgical Oncology* vol. 92, pp. 203-209.
- Georgakoudi, Irene et al. (2001) "Fluorescence, Reflectance, and Light-Scattering Spectroscopy for Evaluating Dysplasia in Patients with Barrett's Esophagus" *Gastroenterology* vol. 120, pp. 1620-1629.
- Adrain, Alyn L. et al. (1997) "High-Resolution Endoluminal Sonography is a Sensitive Modality for the Identification of Barrett's Esophagus" *Gastrointestinal Endoscopy* vol. 46, No. 2, pp. 147-151.
- Canto, Marcia Irene et al (1999) "Vital Staining and Barrett's Esophagus" *Gastrointestinal Endoscopy* vol. 49, No. 3, part 2, pp. 12-16.
- Evans, John A. et al. (2006) "Optical Coherence Tomography to Identify Intramucosal Carcinoma and High-Grade Dysplasia in Barrett's Esophagus" *Clinical Gastroenterology and Hepatology* vol. 4, pp. 38-3.
- Ponerros, John M. et al. (2001) "Diagnosis of Specialized Intestinal Metaplasia by Optical Coherence Tomography" *Gastroenterology* vol. 120, pp. 7-12.
- Ho, W. Y. et al. (2005) "115 KHz Tuning Repetition Rate Ultrahigh-Speed Wavelength-Swept Semiconductor Laser" *Optics Letters* vol. 30, No. 23, pp. 3159-3161.
- Brown, Stanley B. et al. (2004) "The Present and Future Role of Photodynamic Therapy in Cancer Treatment" *The Lancet Oncology* vol. 5, pp. 497-508.
- Boogert, Jolanda Van Den et al. (1999) "Endoscopic Ablation Therapy for Barrett's Esophagus with High-Grade Dysplasia: A Review" *The American Journal of Gastroenterology* vol. 94, No. 5, pp. 1153-1160.
- Sampliner, Richard E. et al. (1996) "Reversal of Barrett's Esophagus with Acid Suppression and Multipolar Electrocoagulation: Preliminary Results" *Gastrointestinal Endoscopy* vol. 44, No. 5, pp. 532-535.
- Sampliner, Richard E. (2004) "Endoscopic Ablative Therapy for Barrett's Esophagus: Current Status" *Gastrointestinal Endoscopy* vol. 59, No. 1, pp. 66-69.
- Soetikno, Roy M. et al. (2003) "Endoscopic Mucosal resection" *Gastrointestinal Endoscopy* vol. 57, No. 4, pp. 567-579
- Ganz, Robert A. et al. (2004) "Complete Ablation of Esophageal Epithelium with a Balloon-based Bipolar Electrode: A Phased

(56)

## References Cited

## OTHER PUBLICATIONS

- Evaluation in the Porcine and in the Human Esophagus" *Gastrointestinal Endoscopy* vol. 60, No. 6, pp. 1002-1010.
- Pfefer, Jorje et al. (2006) "Performance of the Aer-O-Scope, a Pneumatic, Self Propelling, Self Navigating Colonoscope in Animal Experiments" *Gastrointestinal Endoscopy* vol. 63, No. 5, pp. AB223.
- Overholt, Bergein F. et al. (1999) "Photodynamic Therapy for Barrett's Esophagus: Follow-Up in 100 Patients" *Gastrointestinal Endoscopy* vol. 49, No. 1, pp. 1-7.
- Vogel, Alfred et al. (2003) "Mechanisms of Pulsed Laser Ablation of Biological Tissues" *American Chemical Society* vol. 103, pp. 577-644.
- McKenzie, A. L. (1990) "Physics of Thermal Processes in Laser-Tissue Interaction" *Phys. Med. Biol* vol. 35, No. 9, pp. 1175-1209
- Anderson, R. Rox et al. (1983) "Selective Photothermolysis" Precise Microsurgery by Selective Absorption of Pulsed Radiation *Science* vol. 220, No. 4596, pp. 524-527.
- Jacques, Steven L. (1993) "Role of Tissue Optics and Pulse Duration on Tissue Effects During High-Power Laser Irradiation" *Applied Optics* vol. 32, No. 13, pp. 2447-2454.
- Nahen, Kester et al. (1999) "Investigations on Acoustic On-Line Monitoring of IR Laser Ablation of burned skin" *Lasers in Surgery and Medicine* vol. 25, pp. 69-78.
- Jerath, Maya R. et al. (1993) "Calibrated Real-Time Control of Lesion Size Based on Reflectance Images" *Applied Optics* vol. 32, No. 7, pp. 1200-1209.
- Jerath, Maya R. et al. (1992) "Dynamic Optical Property Changes: Implications for Reflectance Feedback Control of Photocoagulation" *Journal of Photochemical, Photobiology: B: Biol* vol. 16, pp. 113-126.
- Deckelbaum, Lawrence I. (1994) "Coronary Laser Angioplasty" *Lasers in Surgery and Medicine* vol. 14, pp. 101-110
- Kim, B.M. et al. (1998) "Optical Feedback Signal for Ultrashort Laser Pulse Ablation of Tissue" *Applied Surface Science* vol. 127-129, pp. 857-862.
- Brinkman, Ralf et al. (1996) "Analysis of Cavitation Dynamics During Pulsed Laser Tissue Ablation by Optical On-Line Monitoring" *IEEE Journal of Selected Topics in Quantum Electronics* vol. 2, No. 4, pp. 826-835.
- Whelan, W.M. et al. (2005) "A novel Strategy for Monitoring Laser Thermal Therapy Based on Changes in Optothermal Properties of Heated Tissues" *International Journal of Thermophysics* vol. 26., No. 1, pp. 233-241.
- Thomsen, Sharon et al. (1990) "Microscopic Correlates of Macroscopic Optical Property Changes During Thermal Coagulation of Myocardium" *SPIE* vol. 1202, pp. 2-11.
- Khan, Misban Huzaira et al. (2005) "Intradermally Focused Infrared Laser Pulses: Thermal Effects at Defined Tissue Depths" *Lasers in Surgery and Medicine* vol. 36, pp. 270-280.
- Neumann, R.A. et al. (1991) "Enzyme Histochemical Analysis of Cell Viability After Argon Laser-Induced Coagulation Necrosis of the Skin" *Journal of the American Academy of Dermatology* vol. 25, No. 6, pp. 991-998.
- Nadkarni, Seemantini K. et al (2005) "Characterization of Atherosclerotic Plaques by Laser Speckle Imaging" *Circulation* vol. 112, pp. 885-892.
- Zimnyakov, Dmitry A. et al (2002) "Speckle-Contrast Monitoring of Tissue Thermal Modification" *Applied Optics* vol. 41, No. 28, pp. 5989-5996.
- Morelli, J.G., et al (1986) "Tunable Dye Laser (577 nm) Treatment of Port Wine Stains" *Lasers in Surgery and Medicine* vol. 6, pp. 94-99.
- French, P.M.W. et al. (1993) "Continuous-wave Mode-Locked Cr<sup>4+</sup>: YAG Laser" *Optics Letters* vol. 18, No. 1, pp. 39-41.
- Sennaroglu, Alphan et al. (1995) "Efficient Continuous-Wave Chromium-Doped YAG Laser" *Journal of Optical Society of America* vol. 12, No. 5, pp. 930-937.
- Bouma, B et al. (1994) "Hybrid Mode Locking of a Flash-Lamp-Pumped Ti: Al<sub>2</sub>O<sub>3</sub> Laser" *Optics Letters* vol. 19, No. 22, pp. 1858-1860.
- Bouma, B et al. (1995) "High Resolution Optical Coherence Tomography Imaging Using a Mode-Locked Ti: Al<sub>2</sub>O<sub>3</sub> Laser Source" *Optics Letters* vol. 20, No. 13, pp. 1486-1488.
- Fernández, Cabrera Delia et al. "Automated detection of retinal layer structures on optical coherence tomography images", *Optics Express* vol. 13, No. 25, Oct. 4, 2005, pp. 10200-10216.
- Ishikawa, Hiroshi et al. "Macular Segmentation with optical coherence tomography", *Investigative Ophthalmology & Visual Science*, vol. 46, No. 6, Jun. 2005, pp. 2012-2017.
- Hariri, Lida P. et al. "Endoscopic Optical Coherence Tomography and Laser-Induced Fluorescence Spectroscopy in a Murine Colon Cancer Model", *Laser in Surgery and Medicine*, vol. 38, 2006, pp. 305-313.
- PCT International Search Report and Written Opinion for Application No. PCT/US2006/031905 dated May 3, 2007.
- PCT International Search Report and Written Opinion for Application No. PCT/US2007/060481 dated May 23, 2007.
- PCT International Search Report and Written Opinion for Application No. PCT/US2007/060717 dated May 24, 2007.
- PCT International Search Report and Written Opinion for Application No. PCT/US2007/060319 dated Jun. 6, 2007.
- D. Yelin et al., "Three-dimensional imaging using spectral encoding heterodyne interferometry", *Optics Letters*, Jul. 15, 2005, vol. 30, No. 14, pp. 1794-1796.
- Akiba, Masahiro et al. "En-face optical coherence imaging for three-dimensional microscopy", *SPIE*, 2002, pp. 8-15.
- Office Action dated Aug. 10, 2007 for U.S. Appl. No. 10/997,789.
- Office Action dated Feb. 2, 2007 for U.S. Appl. No. 11/174,425.
- PCT International Search Report and Written Opinion for Application No. PCT/US2007/060657 dated Aug. 13, 2007.
- Lewis, Neil E. et al., (2006) "Applications of Fourier Transform Infrared Imaging Microscopy in Neurotoxicity", *Annals New York Academy of Sciences*, Dec. 17, 2006, vol. 820, pp. 234-246.
- Joo, Chulmin et al., Spectral-domain optical coherence phase microscopy for quantitative phase-contrast imaging, *Optics Letters*, Aug. 15, 2005, vol. 30, No. 16, pp. 2131-2133.
- Guo, Bujin et al., "Laser-based mid-infrared reflectance imaging of biological tissues", *Optics Express*, Jan. 12, 2004, vol. 12, No. 1, pp. 208-219.
- Office Action dated Mar. 28, 2007 for U.S. Appl. No. 11/241,907.
- Office Action dated May 23, 2007 for U.S. Appl. No. 10/406,751.
- Office Action dated May 23, 2007 for U.S. Appl. No. 10/551,735.
- PCT International Search Report and Written Opinion for Application No. PCT/US2007/061815 dated Aug. 2, 2007.
- Sir Randall, John et al., "Brillouin scattering in systems of biological significance", *Phil. Trans. R. Soc. Lond. A* 293, 1979, pp. 341-348.
- Takagi, Yasunari, "Application of a microscope to Brillouin scattering spectroscopy", *Review of Scientific Instruments*, No. 12, Dec. 1992, pp. 5552-5555.
- Lees, S. et al., "Studies of Compact Hard Tissues and Collagen by Means of Brillouin Light Scattering", *Connective Tissue Research*, 1990, vol. 24, pp. 187-205.
- Berovic, N. "Observation of Brillouin scattering from single muscle fibers", *European Biophysics Journal*, 1989, vol. 17, pp. 69-74.
- PCT International Search Report and Written Opinion for Application No. PCT/US2007/062465 dated Aug. 8, 2007.
- Pythila John W. et al., "Rapid, depth-resolved light scattering measurements using Fourier domain, angle-resolved low coherence interferometry", *Optics Society of America*, 2004.
- Pythila John W. et al., "Determining nuclear morphology using an improved angle-resolved low coherence interferometry system", *Optics Express*, Dec. 15, 2003, vol. 11, No. 25, pp. 3473-3484.
- Desjardins A.E., et al., "Speckle reduction in OCT using massively-parallel detection and frequency-domain ranging", *Optics Express*, May 15, 2006, vol. 14, No. 11, pp. 4736-4745.
- Nadkarni, Seemantini K., et al., "Measurement of fibrous cap thickness in atherosclerotic plaques by spatiotemporal analysis of laser speckle images", *Journal of Biomedical Optics*, vol. 11 Mar./Apr. 2006, pp. 021006-1-021008.

(56)

## References Cited

## OTHER PUBLICATIONS

- PCT International Search Report and Written Opinion for Application No. PCT/US2007/066017 dated Aug. 30, 2007.
- Yamanari M. et al., "Polarization sensitive Fourier domain optical coherence tomography with continuous polarization modulation", Proc. of SPIE, vol. 6079, 2006.
- Zhang Jun et al., "Full range polarization-sensitive Fourier domain optical coherence tomography", Optics Express, Nov. 29, 2004, vol. 12, No. 24, pp. 6033-6039.
- European Patent Office Search report for Application No. 01991092.6-2305 dated Jan. 12, 2006.
- PCT International Search Report and Written Opinion for Application No. PCT/US2007/060670 dated Sep. 21, 2007.
- J. M. Schmitt et al., (1999) "Speckle in Optical Coherence Tomography: An Overview", SPIE vol. 3726, pp. 450-461.
- Office Action dated Oct. 11, 2007 for U.S. Appl. No. 11/534,095.
- Office Action dated Oct. 9, 2007 for U.S. Appl. No. 09/709,162.
- Notice of Allowance dated Oct. 3, 2007 for U.S. Appl. No. 11/225,840.
- Siavash Yazdanfar et al., "In Vivo imaging in blood flow in human retinal vessels using color Doppler optical coherence tomography", SPIE, 1999 vol. 3598, pp. 177-184.
- Office Action dated Oct. 30, 2007 for U.S. Appl. No. 11/670,069.
- Tang C. L. et al., "Wide-band electro-optical tuning of semiconductor lasers", Applied Physics Letters, vol. 30, No. 2, Jan. 15, 1977, pp. 113-116.
- Tang C. L. et al., "Transient effects in wavelength-modulated dye lasers", Applied Physics Letters, vol. 26, No. 9, May 1, 1975, pp. 534-537.
- Telle M. John, et al., "Very rapid tuning of cw dye laser", Applied Physics Letters, vol. 26, No. 10, May 15, 1975, pp. 572-574.
- Telle M. John, et al., "New method for electro-optical tuning of tunable lasers", Applied Physics Letters, vol. 24, No. 2, Jan. 15, 1974, pp. 85-87.
- Schmitt M. Joseph et al. "OCT elastography: imaging microscopic deformation and strain of tissue", Optics Express, vol. 3, No. 6, Sep. 14, 1998, pp. 199-211.
- M. Gualini Muddassir et al., "Recent Advancements of Optical Interferometry Applied to Medicine", IEEE Transactions on Medical Imaging, vol. 23, No. 2, Feb. 2004, pp. 205-212.
- Maurice L. Roch et al. "Noninvasive Vascular Elastography: Theoretical Framework", IEEE Transactions on Medical Imaging, vol. 23, No. 2, Feb. 2004, pp. 164-180.
- Kirkpatrick J. Sean et al. "Optical Assessment of Tissue Mechanical Properties", Proceedings of the SPIE—The International Society for Optical Engineering SPIE—vol. 4001, 2000, pp. 92-101.
- Lisauskas B. Jennifer et al., "Investigation of Plaque Biomechanics from Intravascular Ultrasound Images using Finite Element Modeling", Proceedings of the 19<sup>th</sup> International Conference—IEEE Oct. 30-Nov. 2, 1997, pp. 887-888.
- Parker K. J. et al., "Techniques for Elastic Imaging: A Review", IEEE Engineering in Medicine and Biology, Nov./Dec. 1996, pp. 52-59.
- European Patent Office Search Report dated Nov. 20, 2007 for European Application No. 05791226.3.
- Dubois Arnaud et al., "Ultra-high-resolution OCT using white-light interference microscopy", Proceedings of SPIE, 2003, vol. 4956, pp. 14-21.
- Office Action dated Jan. 3, 2008 for U.S. Appl. No. 10/997,789.
- Office Action dated Dec. 21, 2007 for U.S. Appl. No. 11/264,655.
- Office Action dated Dec. 18, 2007 for U.S. Appl. No. 11/288,994.
- Office Action dated Jan. 10, 2008 for U.S. Appl. No. 11/435,228.
- Office Action dated Jan. 10, 2008 for U.S. Appl. No. 11/410,937.
- Office Action dated Jan. 11, 2008 for U.S. Appl. No. 11/445,990.
- Office Action dated Feb. 4, 2008 for U.S. Appl. No. 10/861,179.
- PCT International Search Report and Written Opinion for Application No. PCT/US2007/061463 dated Jan. 23, 2008.
- PCT International Search Report and Written Opinion for Application No. PCT/US2007/061481 dated Mar. 17, 2008.
- PCT International Search Report and Written Opinion for Application No. PCT/US2007/078254 dated Mar. 28, 2008.
- Sadhvani, Ajay et al., "Determination of Teflon thickness with laser speckle I. Potential for burn depth diagnosis", Optical Society of America, 1996, vol. 35, No. 28, pp. 5727-5735.
- C.J. Stewart et al., "A comparison of two laser-based methods for determination of burn scar perfusion: Laser Doppler versus laser speckle imaging", Elsevier Ltd., 2005, vol. 31, pp. 744-752.
- G. J. Tearney et al., "Atherosclerotic plaque characterization by spatial and temporal speckle pattern analysis", CLEO 2001, vol. 56, pp. 307-307.
- PCT International Search Report for Application No. PCT/US2007/068233 dated Feb. 21, 2008.
- PCT International Search Report for Application No. PCT/US2007/060787 dated Mar. 18, 2008.
- Statement under Article 19 and Reply to PCT Written Opinion for PCT International Application No. PCT/US2005/043951 dated Jun. 6, 2006.
- PCT International Preliminary Report on Patentability for Application No. PCT/US2005/043951 dated Jun. 7, 2007.
- Poneros er al: "Optical Coherence Tomography of the Biliary Tree During ERCP", Gastrointestinal Endoscopy, Elsevier, NL, vol. 55, No. 1, Jan. 1, 2002, pp. 84-88.
- Fu L e tal: Double-Clad Photonic America, Coupler for compact Nonlinear Optical Microscopy Imaging, Optics Letters, OSA, Optical Society of America, vol. 31, No. 10, May 15, 2006, pp. 1471-1473.
- Japanese language Appeal Decision dated Jan. 10, 2012 for JP 2006-503161.
- Japanese Notice of Grounds for Rejection dated Oct. 28, 2011 for JP2009-294737.
- Japanese Notice of Grounds for Rejection dated Dec. 28, 2011 for JP2008-535793.
- Japanese Notice of Reasons for Rejection dated Dec. 12, 2011 for JP 2008-533712.
- International Search Report and Written Opinion mailed Feb. 9, 2012 based on PCT/US2011/034810.
- Japanese Notice of Reasons for Rejection dated Mar. 27, 2012 for JP 2003-102672.
- Japanese Notice of Reasons for Rejection dated May 8, 2012 for JP 2008-533727.
- Korean Office Action dated May 25, 2012 for KR 10-2007-7008116.
- Japanese Notice of Reasons for Rejection dated May 21, 2012 for JP 2008-551523.
- Japanese Notice of Reasons for Rejection dated Jun. 20, 2012 for JP 2009-546534.
- European Official Communication dated Aug. 1, 2012 for EP 10193526.0.
- European Search Report dated Jun. 25, 2012 for EP 10733985.5.
- Wieser, Wolfgang et al., "Multi-Megahertz OCT: High Quality 3D Imaging at 20 million A-Scans and 4.5 Gvoxels Per Second" Jul. 5, 2010, vol. 18, No. 14, Optics Express.
- European Communication Pursuant to EPC Article 94(3) for EP 07845206.7 dated Aug. 30, 2012.
- International Search Report and Written Opinion mailed Aug. 30, 2012 for PCT/US2012/035234.
- Guiliano, Scarcelli et al., "Three-Dimensional Brillouin Confocal Microscopy", Optical Society of American, 2007, CtuV5.
- Giuliano, Scarcelli et al., "Contocal Brillouin Microscopy for Three-Dimensional Mechanical Imaging." Nat Photonics, Dec. 9, 2007.
- Japanese Notice of Reasons for Rejections dated Oct. 10, 2012 for 2008-553511.
- W.Y. Oh et al: "High-Speed Polarization Sensitive Optical Frequency Domain Imaging with Frequency Multiplexing", Optics Express, vol. 16, No. 2, Jan. 1, 2008.
- Atbey, B.D. et al., "Development and Demonstration of a Networked Telepathology 3-D Imaging, Databasing, and Communication System", 1998 ("C2"), pp. 5-17.

(56)

## References Cited

## OTHER PUBLICATIONS

- D'Amico, A.V., et al., "Optical Coherence Tomography as a Method for Identifying Benign and Malignant Microscopic Structures in the Prostate Gland", *Urology*, vol. 55, Issue 5, May 2000 ("C3"), pp. 783-787.
- Tearney, G.J. et al., "In Vivo Endoscopic Optical Biopsy with Optical Coherence Tomography", *Science*, vol. 276, No. 5321, Jun. 27, 1997 ("C6"), pp. 2037-2039.
- Japanese Notice of Reasons for Rejections dated Oct. 2, 2012 for 2007-543626.
- Canadian Office Action dated Oct. 10, 2012 for 2,514,189.
- Japanese Notice of Reasons for Rejections dated Nov. 9, 2012 for JP 2007-530134.
- Japanese Notice of Reasons for Rejections dated Nov. 27, 2012 for JP 2009-554772.
- Japanese Notice of Reasons for Rejections dated Oct. 11, 2012 for JP 2008-533712.
- Yoden, K. et al., "An Approach to Optical Reflection Tomography Along the Geometrical Thickness," *Optical Review*, vol. 7, No. 5, Oct. 1, 2000.
- International Search Report and Written Opinion mailed Oct. 25, 2012 for PCT/US2012/047415.
- Joshua, Fox et al.: "Measuring Primate RNFL Thickness with OCT", *IEEE Journal of Selected Topics in Quantum Electronics*, IEEE Service Center, Piscataway, NJ, US, vol. 7, No. 6, Nov. 1, 2001.
- European Official Communication dated Feb. 6, 2013 for 04822169.1.
- International Search Report mailed Jan. 31, 2013 for PCT/US2012/061135.
- Viliyam K. Pratt. *Lazernye Sistemy Svyazi*. Moskva, Izdatelstvo "Svyaz", 1972. p. 68-70.
- International Search Report and Written Opinion mailed Jan. 31, 2013 for PCT/US2012/060843.
- European Search Report mailed on Mar. 11, 2013 for EP 10739129.4.
- Huber, R et al.: "Fourier Domain Mode Locked Lasers for OCT Imaging at up to 290 kHz Sweep Rates", *Proceedings of SPIE*, SPIE—International Society for Optical Engineering, US, vol. 5861, No. 1, Jan. 1, 2005.
- M. Kourogi et al.: "Programmable High Speed (1MHz) Vernier-mode-locked Frequency-Swept Laser for OCT Imaging", *Proceedings of SPIE*, vol. 6847, Feb. 7, 2008.
- Notice of Reasons for Rejection dated Feb. 5, 2013 for JP 2008-509233.
- Notice of Reasons for Rejection dated Feb. 19, 2013 for JP 2008-507983.
- European Extended Search Report mailed Mar. 26, 2013 for EP 09825421.1.
- Masahiro, Yamanari et al.: "polarization-Sensitive Swept-Source Optical Coherence Tomography with Continuous Source Polarization Modulation", *Optics Express*, vol. 16, No. 8, Apr. 14, 2008.
- European Extended Search Report mailed on Feb. 1, 2013 for EP 12171521.3.
- Nakamura, Koichiro et al., "A New Technique of Optical Ranging by a Frequency-Shifted Feedback Laser", *IEEE Photonics Technology Letters*, vol. 10, No. 12, pp. 1041-1135, Dec. 1998.
- Lee, Seok-Jeong et al., "Ultrahigh Scanning Speed Optical Coherence Tomography Using Optical Frequency Comb Generators", *The Japan Society of Applied Physics*, vol. 40 (2001).
- Kinoshita, Masaya et al., "Optical Frequency-Domain Imaging Microprofilometry with a Frequency-Tunable Liquid-Crystal Fabry-Perot Etalon Device" *Applied Optics*, vol. 38, No. 34, Dec. 1, 1999.
- Notice of Reasons for Rejection mailed on Apr. 16, 2013 for JP 2009-510092.
- Bachmann A.H. et al.: "Heterodyne Fourier Domain Optical Coherence Tomography for Full Range Probing with High Axial Resolution", *Optics Express*, OSA, vol. 14, No. 4, Feb. 20, 2006.
- European Search Report for 12194876.4 dated Feb. 1, 2013.
- International Search Report and Written Opinion for PCT/US2013/022136.
- Thomas J. Flotte: "Pathology Correlations with Optical Biopsy Techniques", *Annals of the New York Academy of Sciences*, Wiley-Blackwell Publishing, Inc. SU, vol. 838, No. 1, Feb. 1, 1998, pp. 143-149.
- Constance R. Chu et al: *Arthroscopic Microscopy of Articular Cartilage Using Optical Coherence Tomography*, American Journal of Sports Medicine, American Orthopedic Society for Sports Medicine, Waltham, MA, Vo. 32, No. 9, Apr. 1, 2004.
- Bouma B E et al: *Diagnosis of Specialized Intestinal Metaplasia of the Esophagus with Optical Coherence Tomography*, Conference on Lasers and Electro-Optics. Technical Digest. OSA, US, vol. 56, May 6, 2001.
- Shen et al: "Ex Vivo Histology-Correlated Optical Coherence Tomography in the Detection of Transmural Inflammation in Crohn's Disease", *Clinical Gastroenterology and Hepatology*, vol. 2, No. 9, Sep. 1, 2004.
- Shen et al: "In Vivo Colonoscopic Optical Coherence Tomography for Transmural Inflammation in Inflammatory Bowel Disease", *Clinical Gastroenterology and Hepatology*, American Gastroenterological Association, US, vol. 2, No. 12, Dec. 1, 2004.
- Ge Z et al: "Identification of Colonic Dysplasia and Neoplasia by Diffuse Reflectance Spectroscopy and Pattern Recognition Techniques", *Applied Spectroscopy*, The Society for Applied Spectroscopy, vol. 52, No. 6, Jun. 1, 1998.
- Elena Zagaynova et al: "Optical Coherence Tomography: Potentialities in Clinical Practice", *Proceedings of SPIE*, Aug. 20, 2004.
- Westphal et al: "Correlation of Endoscopic Optical Coherence Tomography with Histology in the Lower-GI Tract", *Gastrointestinal Endoscopy*, Elsevier, NL, vol. 61, No. 4, Apr. 1, 2005.
- Haggitt et al: "Barrett's Esophagus, Dysplasia, and Adenocarcinoma", *Human Pathology*, Saunders, Philadelphia, PA, US, vol. 25, No. 10, Oct. 1, 1994.
- Gang Yao et al. "Monte Carlo Simulation of an Optical Coherence Tomography Signal in Homogenous Turbid Media," *Physics in Medicine and Biology*, 1999.
- Murakami, K. "A Miniature Confocal Optical Scanning Microscopy for Endoscopes", *Proceedings of SPIE*, vol. 5721, Feb. 28, 2005, pp. 119-131.
- Seok, H. Yun et al: "Comprehensive Volumetric Optical Microscopy in Vivo", *Nature Medicine*, vol. 12, No. 12, Jan. 1, 2007.
- Baxter: "Image Zooming", Jan. 25, 2005, Retrieved from the Internet.
- Qiang Zhou et al: "A Novel Machine Vision Application for Analysis and Visualization of Confocal Microscopic Images" *Machine Vision and Applications*, vol. 16, No. 2, Feb. 1, 2005.
- Igor Gurov et al: (2007) "Full-field High-Speed Optical Coherence Tomography System for Evaluating Multilayer and Random Tissues", *Proc. of SPIE*, vol. 6618.
- Igor Gurov et al: "High-Speed Signal Evaluation in Optical Coherence Tomography Based on Sub-Nyquist Sampling and Kalman Filtering Method" *AIP Coherence Proceedings*, vol. 860, Jan. 1, 2006.
- Groot De P et al: "Three Dimensional Imaging by Sub-Nyquist Sampling of White-Light Interferograms", *Optics Letters*, vol. 18, No. 17, Sep. 1, 1993.
- European Supplemental Search Report for European Application No. 11837061.8 dated on Mar. 24, 2015.
- Japanese Office Action for Japan Application No. 2013-536806 dated on Apr. 21, 2015.
- R. Scott Brock, et al. "Evaluation of a parallel . . . modeling of light scattering by deformed red blood cells", *Optics Express*, 2005, vol. 13, Issue 14, pp. 5279-5292.
- B. J. Vakoc, et al, Phase-resolved optical frequency domain imaging, *Optics Express*, 2005, vol. 13, Issue 14, pp. 5483-5493.

\* cited by examiner

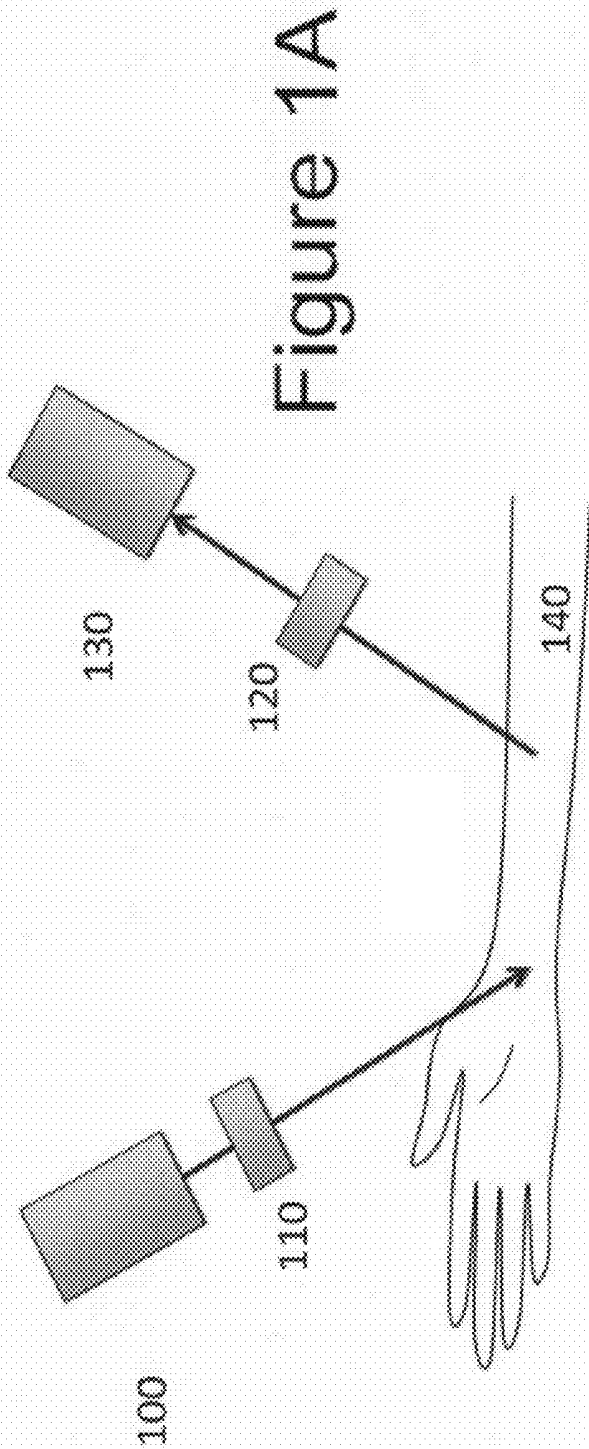

Figure 1A

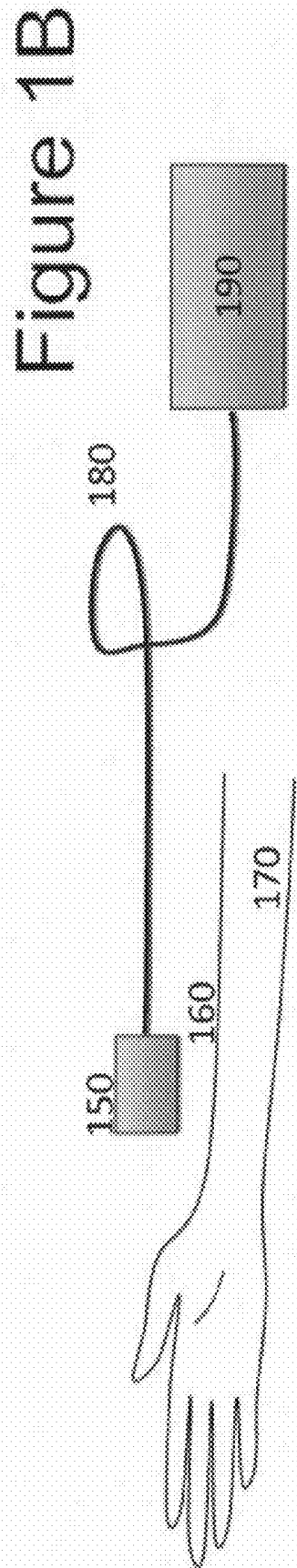

Figure 1B

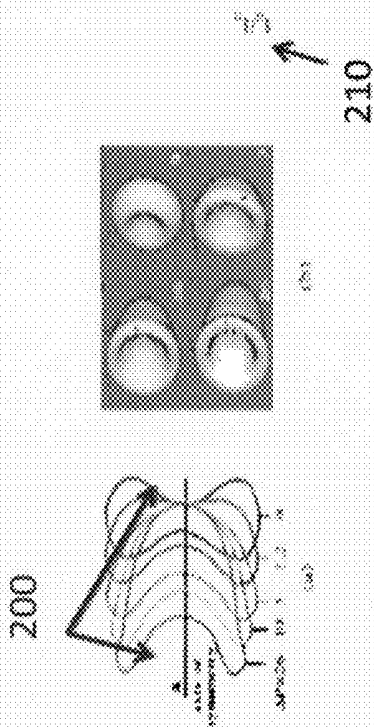

Figure 2A

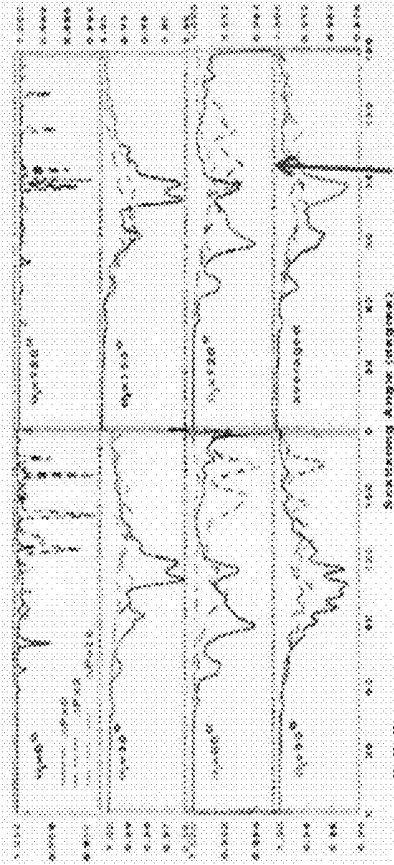

Figure 2B

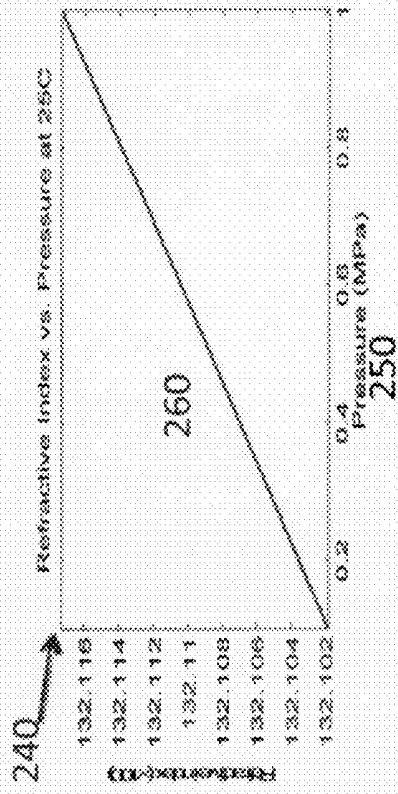

Figure 2C

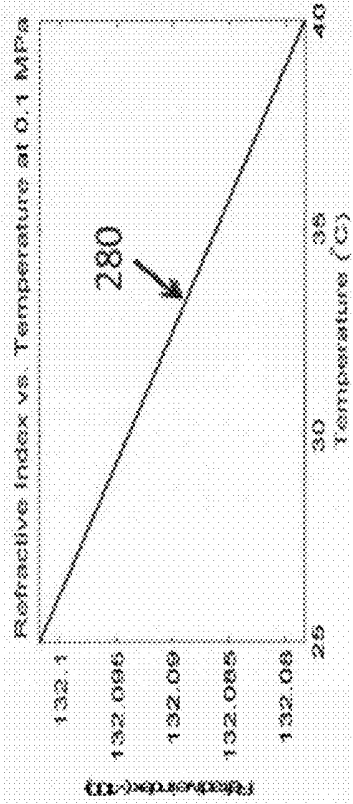

Figure 2D

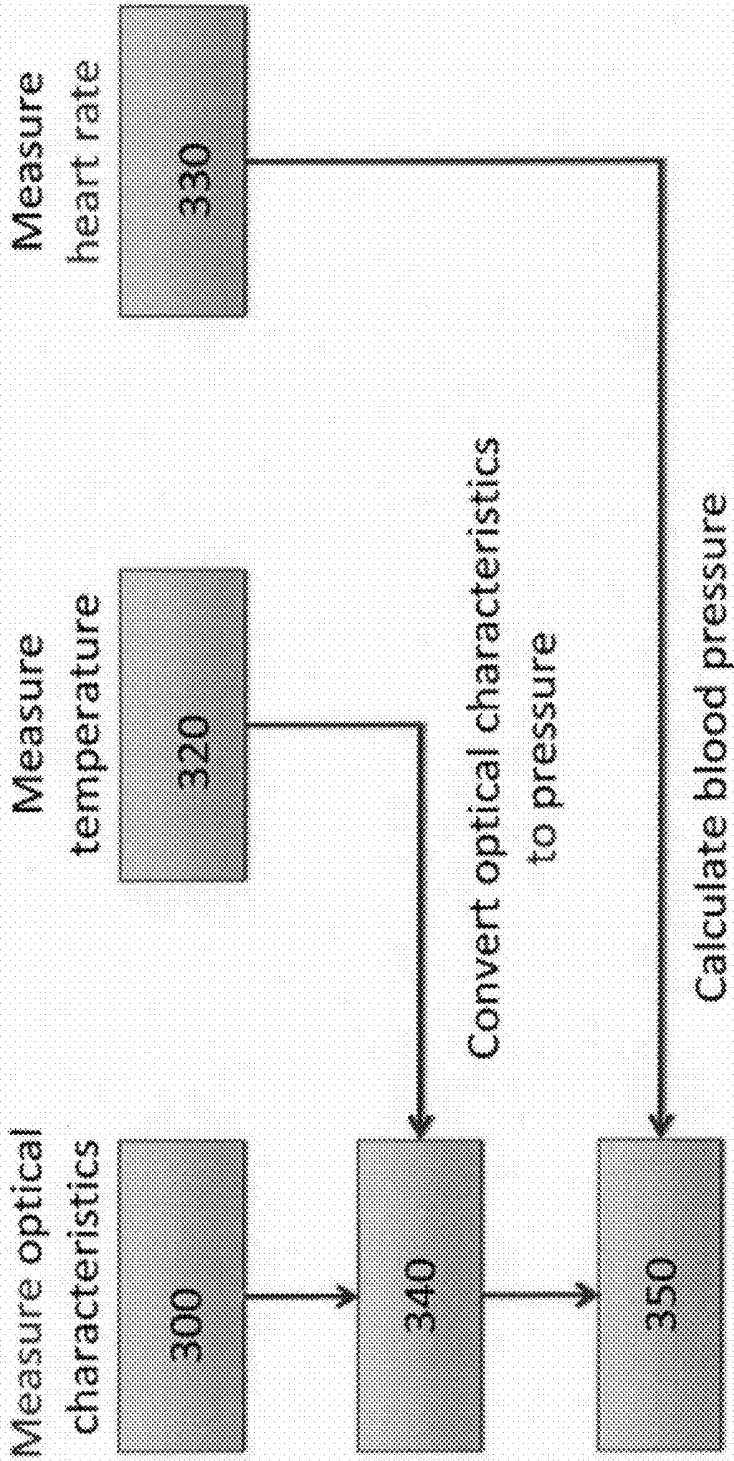

Figure 3

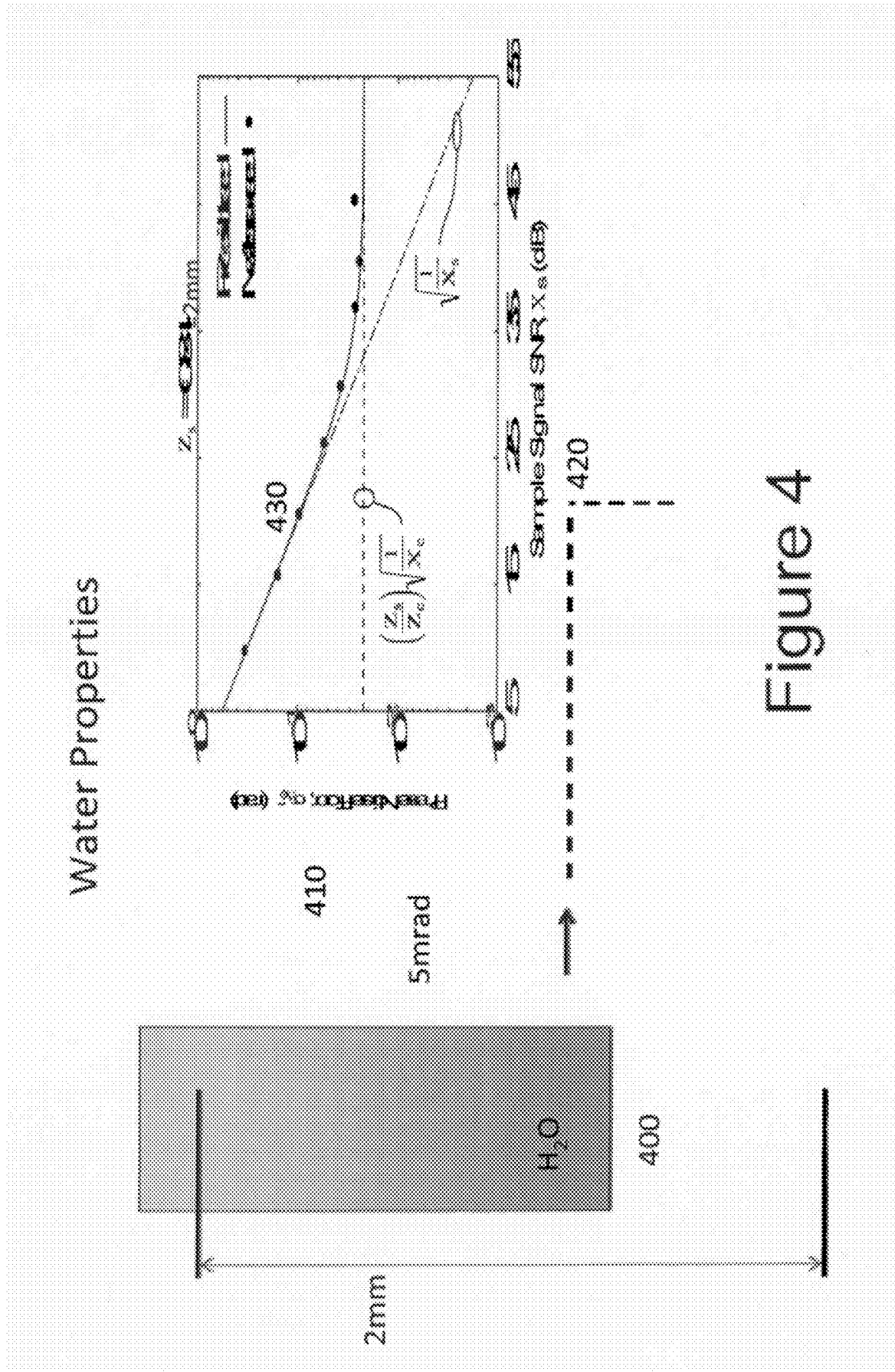

Figure 4

**APPARATUS, SYSTEMS AND METHODS  
FOR MEASURING BLOOD PRESSURE  
WITHIN AT LEAST ONE VESSEL**

CROSS-REFERENCE RELATED  
APPLICATION(S)

This application claims priority from U.S. Patent Application Ser. No. 61/407,368 filed on Oct. 27, 2010, the entire disclosure of which is incorporated herein by reference.

FIELD OF THE DISCLOSURE

Exemplary embodiments of the present disclosure relates generally to measuring apparatus, systems and methods, and more particularly to apparatus, systems and methods for measuring flow and pressure within at least one vessel using an optical measurement external to the vessel(s).

BACKGROUND INFORMATION

Blood pressure is an important parameter for understanding a range of health conditions, from the acute to the chronic. Currently, a sphygmomanometer cuff and an auscultatory technique have been considered as accurate methods to determine the blood pressure, without resorting to invasive methods. However, the use of the sphygmomanometer cuff likely suffers from several shortcomings. For example,

sphygmomanometer cuff generally provides only a non-continuous average blood pressure measurement measurement can suffer from several systematic sources of error and/or restricted to relatively healthy individuals

measurement can likely only be used to ascertain the blood pressure at a limited number of locations on the body

Optical Coherence Tomography (“OCT”), including Fourier Domain OCT, including but not limited to Optical Frequency Domain Imaging (“OFDI”), Swept Source Optical Coherence Tomography (“SS-OCT”), and Spectral-Domain Optical Coherence Tomography (“SD-OCT”)—some of which are described in described in International Patent Application PCT/US2004/029148, filed Sep. 8, 2004 which published as International Patent Publication No. WO 2005/047813 on May 26, 2005, U.S. patent application Ser. No. 11/266,779, filed Nov. 2, 2005 which published as U.S. Patent Publication No. 2006/0093276 on May 4, 2006, and U.S. patent application Ser. No. 10/501,276, filed Jul. 9, 2004 which published as U.S. Patent Publication No. 2005/0018201 on Jan. 27, 2005, and U.S. Patent Publication No. 2002/0122246, published on May 9, 2002), can generally utilize low coherence interferometry and/or optical frequency domain interferometry procedures to measure scattering as a function of depth.

If the blood pressure could be accurately and reliably measured using an external optical measurement, it would facilitate a high-speed beat-to-beat variation in the blood pressure to be monitored in a large number of locations on the body, e.g., by inexpert users, in non-clinical settings.

Previously, other concepts/procedures of utilizing non-invasive optical measurements to estimate the blood pressure within a vessel have been described. Such concepts include Photoplethysmography (see Y.-Z. Yoon and G.-W. Yoon, “Nonconstrained Blood Pressure Measurement by Photoplethysmography,” *J. Opt. Soc. Korea* 10, 91-95 (2006)), laser speckle (see *J. Biomed. Opt.* 15, 061707 (Nov.

22, 2010); doi:10.1117/1.3505008), etc. However, these procedures generally rely on a detection of morphological changes in arteries caused by pressure waves from cardiac output. Thus, these procedures are dependent on hard-to-estimate quantities, such as, e.g., the elasticity of the arterial wall and other physiological factors. These dependencies limit the practicality of such procedures.

Thus, it may be beneficial to address and/or overcome at least some of the deficiencies of the prior approaches, procedures and/or systems that have been described herein above.

OBJECTS AND SUMMARY OF EXEMPLARY  
EMBODIMENTS OF DISCLOSURE

It is therefore one of the objects of the present invention to reduce or address the deficiencies and/or limitations of such prior art approaches, procedures and systems. Thus, exemplary procedure, method, system and apparatus can be provided for measuring flow and pressure within at least one vessel using an optical measurement external to the vessel(s), and which overcome at least some of such deficiencies.

For example, according to an exemplary embodiment of the present disclosure, it is possible to convert the optical measurement of blood pressure information into derived clinical parameters such as, e.g., systolic pressure, diastolic pressure, pulse pressure, mean arterial pressure, and other metrics known to those having ordinary skill the art. Further, according to one exemplary embodiment of the present disclosure, an exemplary correlation procedure, system and apparatus can be provided that can have, e.g., reduced or minimal location limitations, and can be implemented (e.g., either partially or entirely) via a software arrangement or a software program.

In a particular exemplary embodiment of the present disclosure, it is possible to utilize an existing OCT (or other optical measurement modality) device, system, method and/or apparatus which can be configured for, e.g., an external measurement of the external, brachial subclavian artery, radial, ulnar or carotid artery to obtain information regarding blood pressure within the artery.

According to a further exemplary embodiment of the present disclosure, apparatus, system and method for obtaining information for at least one structure can be provided. For example, it is possible (e.g., using at least one first arrangement) to forward at least one first electro-magnetic radiation to the at least one structure which is external from the apparatus. At least one second electro-magnetic radiation provided from the at least one structure (which is based on the first electro-magnetic radiation(s)) can be detected (e.g., using at least one second arrangement). It is also possible (e.g., using at least one third arrangement) to determine at least one characteristic of the structure(s) based on the second electro-magnetic radiation(s), and obtain data relating to a pressure of at least one portion of the structure(s) based on the characteristic(s).

According to another exemplary embodiment of the present disclosure, the characteristic(s) can include (i) a refractive index of the structure(s), and/or (ii) a change of the refractive index. The third arrangement(s) can be further configured to measure a temperature of the portion(s) and/or obtains the data relating to the pressure using the temperature and the characteristic(s). The structure(s) can include an anatomical structure (e.g., a blood vessel), and the pressure can be provided within the blood vessel. The characteristic(s) can relate to a structure of at least one red

blood cell of the portion(s). The anatomical structure can also include a fascial compartment, and the pressure can be provided within the fascial compartment.

According to still another exemplary embodiment of the present disclosure, the first arrangement(s) can be further configured to forward at least one third electro-magnetic radiation to a reference, and the second arrangement(s) can be configured to detect the second electro-magnetic radiation(s) provided from the structure(s) and interfered with at least one fourth radiation provided from the reference which is associated with the third electro-magnetic radiation(s). For example, the first and second arrangements can form (i) low coherence interferometric system, (ii) optical frequency domain imaging system, and/or (iii) spectral domain optical coherence tomography system. The first electro-magnetic radiation(s) can include a light radiation. The second electromagnetic radiation(s) can include a plurality of distinct radiation provided from (i) different spatial locations on the structure(s), or (ii) different temporal locations from the structure(s). The characteristic(s) can include a speckle pattern of the structure(s). The characteristic(s) can further include a refractive index that can be determined based on the speckle pattern. The third arrangement(s) can correlate the speckle pattern with further speckle patterns obtained at different wavelengths or times from the portion(s).

According to yet further exemplary embodiment of the present disclosure the characteristic(s) can include (i) a refractive index of the structure(s), and/or (ii) a change of the refractive index. The second arrangement(s) can detect the electromagnetic radiation based on a wavelength thereof or an angle of remittance from the structure(s) relative to an angle of incidence of the first electromagnetic radiation(s) on the structure(s). The anatomical structure can include (i) an eye, (ii) an ear, (iii) a brain compartment, (iv) a spinal canal, (v) an airway, (vi) a heart cavity, (vii) a gastrointestinal organ, and/or (viii) a bladder. The characteristic(s) can include (i) a phase of the second electromagnetic radiation(s) relative to the first electromagnetic radiation(s), or (ii) a change of the phase. The characteristic(s) can also include (i) a phase of the electromagnetic radiation(s) relative to the fourth electromagnetic radiation(s), or (ii) a change of the phase.

According to another exemplary embodiment of the present disclosure, apparatus, system and method can be provided to measure blood pressure within an anatomical structure. For example, it is possible to use at least one first probe arrangement structured to direct at least one radiation to at least one external portion of the anatomical structure. Further, it is possible to provide at least one second arrangement which is configured to detect the radiation reflected from the anatomical structure. Further, at least one third arrangement can be provided to detect an interference between a first radiation provided from the anatomical structure via the probe arrangement and second a second radiation provided from a reference path as a function of wavelength thereof. In addition, at least one fourth arrangement can be provided which can be configured to determine at least one characteristic of the blood flow as a function of the signal. For example, the fourth arrangement(s) can determine the characteristic(s) as a function of an intensity of the interference and/or as a function of the self-interference (e.g., speckle) pattern generated by first radiation incident on the anatomical structure via the probe arrangement(s).

The first probe arrangement(s) can include a handheld apparatus. The anatomical structure can comprise an artery, vein, or any location on the skin surface. A wavelength of at

least one of the first radiation or the second radiation can vary over time. The second arrangement can include at least one array of detectors, each configured to detect a separate wavelength band of the interference.

The first probe arrangement(s) can be configured to be immobile during operation of the apparatus. The second and/or third arrangement(s) can determine the characteristic as a function of time and/or determine synchronously with a further physiological measurement. The further physiological measurement can be an EKG, temperature or heart rate. The third arrangement(s) can determine the characteristic before and/or after an administration of a pharmacologic agent.

These and other objects, features and advantages of the exemplary embodiment of the present disclosure will become apparent upon reading the following detailed description of the exemplary embodiments of the present disclosure, when taken in conjunction with the appended claims.

#### BRIEF DESCRIPTION OF THE DRAWINGS

Further objects, features and advantages of the present disclosure will become apparent from the following detailed description taken in conjunction with the accompanying figures showing illustrative embodiments of the present disclosure, in which:

FIG. 1A is a block diagram of a first exemplary embodiment of an optical measurement apparatus, system and/or arrangement according to the present disclosure;

FIG. 1B is a block diagram of a second exemplary embodiment of the optical measurement apparatus, system and/or arrangement according to the present disclosure;

FIGS. 2A-2D are exemplary images, diagrams and graphs indicating a change in the optical characteristics of water and blood at different pressures and temperatures;

FIG. 3 is a block diagram describing exemplary procedures utilized by a method, apparatus, system and/or arrangement according to an exemplary embodiment of the present disclosure to measure pressure from optical and other measurements; and

FIG. 4 is are illustration of diagram and graph demonstrating an exemplary minimum resolvable difference in a refractive index that OCT techniques are capable of measuring.

Throughout the figures, the same reference numerals and characters, unless otherwise stated, are used to denote like features, elements, components or portions of the illustrated embodiments. Moreover, while the subject disclosure will now be described in detail with reference to the figures, it is done so in connection with the illustrative embodiments. It is intended that changes and modifications can be made to the described exemplary embodiments without departing from the true scope and spirit of the subject disclosure as defined by the appended claims.

#### DETAILED DESCRIPTION OF EXEMPLARY EMBODIMENTS

A block diagram an optical measurement system according to a first exemplary embodiment of the present disclosure is shown in FIG. 1A. For example, the exemplary system and/or arrangement can include one or more electromagnetic radiation sources (e.g., at least one light source) **100** and conditioning optics **110**, for delivering at least one first radiation to the sample **140**. At least one second radiation, e.g., generated by a reflection of the first

radiation(s) can be passed through detection optics **120**, and is then incident upon a detection and processing arrangement **130**, which can include a processor and a storage medium (e.g., hard drive, CD-ROM, floppy disk, memory stick, combination thereof, etc.).

FIG. **1B** shows a block diagram the optical measurement system according to a second exemplary embodiment of the present disclosure. This exemplary system and/or arrangement can include a handheld probe **150** that can include transmission and detection optics **160** for delivering radiation to the anatomical structure **170**. The exemplary probe **150** can be coupled to an detection and processing system, apparatus or arrangement **190** which can include a processor and a storage medium (e.g., hard drive, CD-ROM, floppy disk, memory stick, combination thereof, etc) at a proximal end thereof (e.g., via an optical fiber **180**).

FIG. **2** illustrates exemplary images, diagrams and graphs indicating a change in the optical characteristics of water and blood at different pressures and temperatures. A summary of relevant optical parameters for blood and water are illustrated at different pressures in FIG. **2**. For example, as the pressure in arteries and capillaries increases, red blood cells become deformed **200**, and thus cause the electromagnetic radiation (e.g., light) to scatter with a different polarization state **210**, and in a different direction **220**, as shown in a graph **230**. In addition, the refractive index of water as shown in a graph **240** can change with a pressure **250** in a linear relationship **260**. A complicating factor can be that the refractive index of water can also change with the temperature **170** in a linearly decreasing relationship **180**. Data can be taken from R. S. Brock, X.-H. Hu, P. Yang, and J. Lu, "Evaluation of a parallel FDTD code and application to modeling of light scattering by deformed red blood cells," Opt. Express **13**, 5279-5292 (2005) and "Release on the Refractive Index of Ordinary Water Substance as a Function of Wavelength, Temperature and Pressure" International Association for the Properties of Water and Steam, Erlangen, Germany, 1997.

FIG. **3** shows an exemplary flow diagram of an exemplary method and/or procedures for a determination of the pressure from an optical measurement according to an exemplary embodiment of the present disclosure. For example, a plurality of independent initial measurements can be calculated. Such exemplary measurements can include, e.g.:

An optical measurement using the apparatus of FIG. **1** as provided in procedure **300**;

A temperature measurement using standard equipment, e.g., an electronic thermometer as provided in procedure **320**

A heart rate measurement using a conventional equipment, e.g., EKG, pulse oximeter, etc, as shown in procedure **330**.

In the next step **340** of the determination procedure, the optical measurement can be converted to the pressure using the exemplary parameters described herein and shown in FIG. **2**. Furthermore, the temperature measurement can be used to compensate for errors in the calculation caused by changes in the temperature. The next step **350** in the exemplary determination procedure can utilize the heart rate measurement **330** to increase sensitivity of the measurement by rejecting non-cardiac changes in the signal through the use of, e.g., a lock-in detection mechanism.

The exemplary optical apparatuses shown in FIGS. **1A** and **1B** can be configured to detect extremely small changes in scattering and refractive index. The refractive index changes associated with physiological changes in pressure can be on the order of, e.g.,  $1 \times 10^{-6}$  per 50 mmHg. If

detecting this change in a vessel having a 1 mm radius, as shown in an illustration **400** of FIG. **4**, this can lead to a total change in the phase of the light of

$$\theta = \frac{\Delta z \Delta n 2\pi}{\lambda} = \frac{2 \times 1.05e - 6 \times 2\pi}{1310e - 9} = 5 \text{ mrad.}$$

While this exemplary result may seem to be a small quantity, such exemplary changes that can be measured by OFDI and laser speckle imaging exemplary techniques, systems and/or apparatus, among other optical techniques, systems and/or apparatus. As an example, the phase sensitivity of a typical OFDI system can be given by an illustration **410** of FIG. **4**. Such phase sensitivity can be dependent on the sample signal **420**. An exemplary measured curve **430**, as shown in FIG. **4**, decreases with measured signal until it reaches a plateau defined by the signal intensity provided by a reference measurement. If this exemplary reference measurement (which can be provided by a glass coverslip or similar) is sufficiently high, and the sample signal is better than 45 dB, then the exemplary OFDI system can resolve a phase change of less than 5 mrad. These exemplary changes can be linked back to the pressure changes within blood vessels using the exemplary procedures that are shown in the flow diagram shown in FIG. **3**. The data can be provided from: B. J. Vakoc, S. H. Yun, J. F. de Boer, G. J. Tearney, and B. E. Bouma, "Phase-resolved optical frequency domain imaging" Optics Express **13**, 5483 (2005).

The foregoing merely illustrates the principles of the disclosure. Various modifications and alterations to the described embodiments will be apparent to those skilled in the art in view of the teachings herein. Indeed, the arrangements, systems and methods according to the exemplary embodiments of the present disclosure can be used with and/or implement any OCT system, OFDI system, SD-OCT system or other imaging systems, and for example with those described in International Patent Application PCT/US2004/029148, filed Sep. 8, 2004 which published as International Patent Publication No. WO 2005/047813 on May 26, 2005, U.S. patent application Ser. No. 11/266,779, filed Nov. 2, 2005 which published as U.S. Patent Publication No. 2006/0093276 on May 4, 2006, and U.S. patent application Ser. No. 10/501,276, filed Jul. 9, 2004 which published as U.S. Patent Publication No. 2005/0018201 on Jan. 27, 2005, and U.S. Patent Publication No. 2002/0122246, published on May 9, 2002, the disclosures of which are incorporated by reference herein in their entireties. It will thus be appreciated that those skilled in the art will be able to devise numerous systems, arrangements and methods which, although not explicitly shown or described herein, embody the principles of the disclosure and are thus within the spirit and scope of the present disclosure. In addition, to the extent that the prior art knowledge has not been explicitly incorporated by reference herein above, it is explicitly being incorporated herein in its entirety. Further, the exemplary embodiments described herein can operate together with one another and interchangeably therewith. All publications referenced herein above are incorporated herein by reference in their entireties.

What is claimed is:

1. An apparatus for obtaining information for at least one anatomical structure, comprising:
  - at least one radiation providing first arrangement configured to forward at least one first electro-magnetic

radiation to and impact the at least one anatomical structure which is external from the apparatus;  
 at least one detector second arrangement configured to detect at least one second electro-magnetic radiation provided from at least one portion within the at least one anatomical structure which is based on the at least one first electro-magnetic radiation; and  
 at least one computer third arrangement configured to (i) determine at least one characteristic of the at least one anatomical structure based on the at least one second electro-magnetic radiation, and (ii) obtain data relating to a pressure of the at least one portion of the at least one anatomical structure based on the at least one characteristic,

wherein the at least one characteristic is a speckle pattern of the at least one portion.

2. The apparatus according to claim 1, wherein the at least one characteristic includes at least one of (i) a refractive index of the at least one structure, or (ii) a change of the refractive index.

3. The apparatus according to claim 1, wherein the at least one third arrangement is further configured to measure a temperature of the at least one portion.

4. The apparatus according to claim 1, wherein the anatomical structure includes a blood vessel.

5. The apparatus according to claim 4, wherein the pressure is provided within the blood vessel.

6. The apparatus according to claim 4, wherein the at least one characteristic relates to a structure of at least one red blood cell of the at least one portion.

7. The apparatus according to claim 1, wherein the anatomical structure includes a fascial compartment.

8. The apparatus according to claim 7, wherein the pressure is provided within the fascial compartment.

9. The apparatus according to claim 1, wherein the at least one first arrangement is further configured to forward at least one third electro-magnetic radiation to a reference, and wherein the at least one second arrangement is configured to detect the at least one second electro-magnetic radiation provided from the at least one structure and interfered with at least one fourth radiation provided from the reference which is associated with the at least one third electro-magnetic radiation.

10. The apparatus according to claim 9, wherein the first and second arrangements form at least one of (i) low coherence interferometric system, (ii) optical frequency domain imaging system, or (iii) spectral domain optical coherence tomography system.

11. The apparatus according to claim 9, wherein the at least one characteristic includes at least one of (i) a phase of the at least one second electromagnetic radiation relative to the at least one fourth electromagnetic radiation, or (ii) a change of the phase.

12. The apparatus according to claim 9, wherein the at least one third arrangement is further configured to measure a temperature of the at least one portion, wherein the at least one third arrangement obtains the data relating to the pressure using the temperature and the at least one characteristic.

13. The apparatus according to claim 1, wherein the at least one first electro-magnetic radiation is a light radiation.

14. The apparatus according to claim 1, wherein the at least one second electromagnetic radiation is a plurality of distinct radiation provided from (i) different spatial locations on the at least one structure, or (ii) different temporal locations from the at least one structure.

15. The apparatus according to claim 1, wherein the at least one characteristic includes at least one of (i) a refractive index of the at least one structure, or (ii) a change of the refractive index.

16. The apparatus according to claim 1, wherein the at least one second arrangement detects the at least one second electromagnetic radiation based on a wavelength thereof or an angle of remittance from the at least one structure relative to an angle of incidence of the at least one first electromagnetic radiation on the at least one structure.

17. The apparatus according to claim 1, wherein the anatomical structure includes at least one of (i) an eye, (ii) an ear, (iii) a brain compartment, (iv) a spinal canal, (v) an airway, (vi) a heart cavity, (vii) a gastro-intestinal organ, or (viii) a bladder.

18. The apparatus according to claim 1, wherein the at least one characteristic includes at least one of (i) a phase of the at least one second electromagnetic radiation relative to the at least one first electromagnetic radiation, or (ii) a change of the phase.

19. An apparatus for obtaining information for at least one anatomical structure, comprising:

at least one radiation providing first arrangement configured to forward at least one first electro-magnetic radiation to and impact the at least one anatomical structure which is external from the apparatus;

at least one detector second arrangement configured to detect at least one second electro-magnetic radiation provided from at least one portion within the at least one anatomical structure which is based on the at least one first electro-magnetic radiation; and

at least one computer third arrangement configured to (i) determine at least one characteristic of the at least one anatomical structure based on the at least one second electro-magnetic radiation, and (ii) obtain data relating to a pressure of the at least one portion of the at least one anatomical structure based on the at least one characteristic,

wherein the at least one third arrangement is further configured to measure a temperature of the at least one portion, and

wherein the at least one third arrangement obtains the data relating to the pressure using the temperature and the at least one characteristic.

20. An apparatus for obtaining information for at least one anatomical structure, comprising:

at least one radiation providing first arrangement configured to forward at least one first electro-magnetic radiation to and impact the at least one anatomical structure which is external from the apparatus;

at least one detector second arrangement configured to detect at least one second electro-magnetic radiation provided from at least one portion within the at least one anatomical structure which is based on the at least one first electro-magnetic radiation; and

at least one computer third arrangement configured to (i) determine at least one characteristic of the at least one anatomical structure based on the at least one second electro-magnetic radiation, and (ii) obtain data relating to a pressure of the at least one portion of the at least one anatomical structure based on the at least one characteristic,

wherein the at least one characteristic further includes a refractive index that is determined based on a speckle pattern of the at least one portion.

21. The apparatus according to claim 20, wherein the at least one third arrangement correlates the speckle pattern

with further speckle patterns obtained at different wave-lengths or times from the at least one portion.

22. A method for obtaining information for at least one anatomical structure which is performed by an apparatus, comprising:

forwarding at least one first electro-magnetic radiation to and impacting the at least one anatomical structure which is external from the apparatus;

detecting at least one second electro-magnetic radiation provided from at least one portion within the at least one anatomical structure which is based on the at least one first electro-magnetic radiation;

determining at least one characteristic of the at least one anatomical structure based on the at least one second electro-magnetic radiation; and

obtaining data relating to a pressure of at least one portion of the at least one anatomical structure based on the at least one characteristic, wherein the at least one characteristic is a speckle pattern of the at least one portion.

23. The according to claim 22, further comprising:

forwarding at least one third electro-magnetic radiation to a reference;

interfering the at least one second electro-magnetic radiation provided from the at least one structure with at least one fourth radiation provided from the reference, the second and fourth electro-magnetic radiations being based on the first and third electro-magnetic radiations, respectively.

24. The method according to claim 23, further comprising measuring a temperature of the at least one portion, wherein the obtaining of the data relating to the pressure is performed using the temperature and the at least one characteristic.

25. A method for obtaining information for at least one anatomical structure which is performed by an apparatus, comprising:

forwarding at least one first electro-magnetic radiation to and impacting the at least one anatomical structure which is external from the apparatus;

detecting at least one second electro-magnetic radiation provided from at least one portion within the at least one anatomical structure which is based on the at least one first electro-magnetic radiation;

determining at least one characteristic of the at least one anatomical structure based on the at least one second electro-magnetic radiation;

obtaining data relating to a pressure of at least one portion of the at least one anatomical structure based on the at least one characteristic; and

measuring a temperature of the at least one portion, wherein the obtaining of the data relating to the pressure is performed using the temperature and the at least one characteristic.

26. A method for obtaining information for at least one anatomical structure which is performed by an apparatus, comprising:

forwarding at least one first electro-magnetic radiation to and impacting the at least one anatomical structure which is external from the apparatus;

detecting at least one second electro-magnetic radiation provided from at least one portion within the at least one anatomical structure which is based on the at least one first electro-magnetic radiation;

determining at least one characteristic of the at least one anatomical structure based on the at least one second electro-magnetic radiation; and

obtaining data relating to a pressure of at least one portion of the at least one anatomical structure based on the at least one characteristic,

wherein the at least one characteristic further includes a refractive index that is determined based on a speckle pattern of the at least one portion.

\* \* \* \* \*

专利名称(译)	用于测量至少一个容器内的血压的装置，系统和方法		
公开(公告)号	<a href="#">US9510758</a>	公开(公告)日	2016-12-06
申请号	US13/283143	申请日	2011-10-27
[标]申请(专利权)人(译)	通用医疗公司		
申请(专利权)人(译)	总医院CORPORATION		
当前申请(专利权)人(译)	总医院CORPORATION		
[标]发明人	WARGER II WILLIAM C SCHLACHTER SIMON C GARDECKI JOSEPH BOUMA BRETT EUGENE TEARNEY GUILLERMO J		
发明人	WARGER, II, WILLIAM C. SCHLACHTER, SIMON C. GARDECKI, JOSEPH BOUMA, BRETT EUGENE TEARNEY, GUILLERMO J.		
IPC分类号	A61B6/00 A61B5/20 A61B3/14 A61B5/02 A61B5/1455 A61B5/0205 A61B5/12 A61B5/00 A61B5/021		
CPC分类号	A61B5/021 A61B3/14 A61B5/0066 A61B5/02007 A61B5/02055 A61B5/12 A61B5/14558 A61B5/202 A61B5/407 A61B5/4064 A61B5/42 A61B2576/00		
优先权	61/407368 2010-10-27 US		
其他公开文献	US20120108956A1		
外部链接	<a href="#">Espacenet</a> <a href="#">USPTO</a>		

摘要(译)

可以提供用于获得至少一个结构的信息的示例性装置和方法。例如，可以将至少一个第一电磁辐射转发到设备外部的至少一个结构。可以检测从至少一个结构（基于第一电磁辐射）提供的至少一个第二电磁辐射。还可以基于第二电磁辐射确定结构的至少一个特征，并且基于该特征获得与结构的至少一部分的压力有关的数据。（S）。

