



US008088042B2

(12) **United States Patent**
Limma et al.

(10) **Patent No.:** **US 8,088,042 B2**
(45) **Date of Patent:** **Jan. 3, 2012**

(54) **METHOD, SYSTEM, MEASUREMENT DEVICE AND RECEIVING DEVICE FOR PROVIDING FEEDBACK**

(75) Inventors: **Ilkka Limma**, Kempele (FI); **Ville Kampman**, Oulu (FI); **Hannu Moilanen**, Oulu (FI)

(73) Assignee: **Elisa Oyj**, Helsinki (FI)

(*) Notice: Subject to any disclaimer, the term of this patent is extended or adjusted under 35 U.S.C. 154(b) by 338 days.

(21) Appl. No.: **10/581,314**

(22) PCT Filed: **Dec. 7, 2004**

(86) PCT No.: **PCT/FI2004/000741**

§ 371 (c)(1),
(2), (4) Date: **Jul. 7, 2006**

(87) PCT Pub. No.: **WO2005/053524**

PCT Pub. Date: **Jun. 16, 2005**

(65) **Prior Publication Data**

US 2008/0108481 A1 May 8, 2008

(30) **Foreign Application Priority Data**

Dec. 5, 2003 (FI) 20031777

(51) **Int. Cl.**
A63B 71/00 (2006.01)

(52) **U.S. Cl.** **482/8; 482/1; 482/9; 482/901; 434/247**

(58) **Field of Classification Search** **482/1-9, 482/900-902; 434/247**

See application file for complete search history.

(56) **References Cited**

U.S. PATENT DOCUMENTS

4,708,337	A *	11/1987	Shyu	482/54
4,828,257	A *	5/1989	Dyer et al.	482/5
4,919,418	A *	4/1990	Miller	482/6
4,934,694	A *	6/1990	McIntosh	482/9
5,451,192	A *	9/1995	Hefele	482/52
5,690,582	A *	11/1997	Ulrich et al.	482/4
5,807,267	A *	9/1998	Bryars et al.	600/500
5,839,901	A *	11/1998	Karkanen	434/127
5,890,128	A *	3/1999	Diaz et al.	705/2
5,890,995	A *	4/1999	Bobick et al.	482/4
5,941,837	A *	8/1999	Amano et al.	600/595
5,989,188	A *	11/1999	Birkhoelzer et al.	600/300
6,013,007	A *	1/2000	Root et al.	482/8
6,018,677	A *	1/2000	Vidrine et al.	600/520
6,032,108	A *	2/2000	Seiple et al.	702/97
6,287,262	B1 *	9/2001	Amano et al.	600/500
6,513,532	B2 *	2/2003	Mault et al.	600/595
6,515,593	B1 *	2/2003	Stark et al.	340/870.07

(Continued)

FOREIGN PATENT DOCUMENTS

WO 01/42809 A2 6/2001

Primary Examiner — Glenn Richman

(74) *Attorney, Agent, or Firm* — The Nath Law Group; Jerald L. Meyer; Stanley P. Protigal

(57) **ABSTRACT**

A method, system, measurement device and receiving device for providing feedback relating to an activity to at least one individual. In the method, activity information relating to an activity is measured with a measurement device. Activity information is transmitted to a receiving device via a communication link. The receiving device selects from the received activity information a predefined set of pieces of activity information and provides the at least one individual with feedback based on the selected activity information.

29 Claims, 3 Drawing Sheets

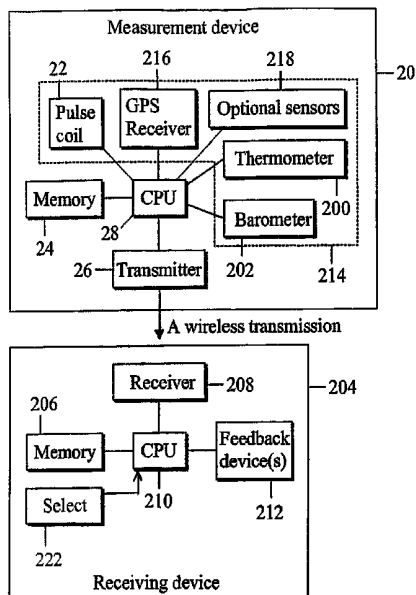

U.S. PATENT DOCUMENTS

6,592,502	B1 *	7/2003	Phillips	482/143	2004/0102684	A1 *	5/2004	Kawanishi et al.	600/300
6,605,044	B2 *	8/2003	Bimbaum	600/500	2004/0198554	A1 *	10/2004	Orr et al.	482/8
6,671,736	B2 *	12/2003	Virine et al.	709/238	2004/0220017	A1 *	11/2004	Gordon et al.	482/8
6,675,041	B2 *	1/2004	Dickinson	600/509	2004/0224822	A1 *	11/2004	Verheem	482/8
6,697,048	B2 *	2/2004	Rosenberg et al.	345/161	2005/0032608	A1 *	2/2005	Glusco	482/9
6,736,759	B1 *	5/2004	Stubbs et al.	482/8	2005/0107218	A1 *	5/2005	Chuang et al.	482/45
6,749,537	B1 *	6/2004	Hickman	482/8	2005/0124463	A1 *	6/2005	Yeo et al.	482/8
6,783,482	B2 *	8/2004	Oglesby et al.	482/54	2005/0130802	A1 *	6/2005	Kinnunen et al.	482/8
6,790,178	B1 *	9/2004	Mault et al.	600/300	2005/0164857	A1 *	7/2005	Black	482/148
6,798,378	B1 *	9/2004	Walters	342/357.06	2005/0197237	A1 *	9/2005	Chen	482/8
6,906,533	B1 *	6/2005	Yoshida	324/692	2005/0209050	A1 *	9/2005	Bartels	482/8
6,921,351	B1 *	7/2005	Hickman et al.	482/8	2005/0209051	A1 *	9/2005	Santomassimo et al.	482/8
6,950,695	B2 *	9/2005	Chen	600/509	2005/0233859	A1 *	10/2005	Takai et al.	482/3
6,982,700	B2 *	1/2006	Rosenberg et al.	345/157	2005/0233861	A1 *	10/2005	Hickman et al.	482/8
7,056,265	B1 *	6/2006	Shea	482/8	2005/0272564	A1 *	12/2005	Pyles et al.	482/54
7,072,789	B2 *	7/2006	Vock et al.	702/141	2006/0020177	A1 *	1/2006	Seo et al.	600/300
7,166,062	B1 *	1/2007	Watterson et al.	482/8	2006/0052727	A1 *	3/2006	Palestrant	600/595
7,187,960	B2 *	3/2007	Abreu	600/310	2006/0063644	A1 *	3/2006	Yang	482/4
7,220,220	B2 *	5/2007	Stubbs et al.	482/72	2006/0098772	A1 *	5/2006	Reho et al.	377/24.2
7,229,416	B2 *	6/2007	Chen	600/500	2006/0183602	A1 *	8/2006	Astilean	482/7
7,232,416	B2 *	6/2007	Czernicki	600/595	2006/0183603	A1 *	8/2006	Astilean	482/8
RE39,906	E *	11/2007	Roston et al.	318/561	2006/0189437	A1 *	8/2006	Cohen et al.	482/7
7,305,303	B2 *	12/2007	Soehren et al.	701/221	2006/0229163	A1 *	10/2006	Waters	482/8
7,312,766	B1 *	12/2007	Edwards	345/8	2007/0021269	A1 *	1/2007	Shum	482/8
7,344,508	B2 *	3/2008	Surina	600/587	2007/0033068	A1 *	2/2007	Rao et al.	705/2
7,359,624	B2 *	4/2008	Adams et al.	386/124	2007/0033069	A1 *	2/2007	Rao et al.	705/2
7,373,820	B1 *	5/2008	James	73/488	2007/0142177	A1 *	6/2007	Simms et al.	482/8
2003/0022140	A1 *	1/2003	Chang	434/247	2007/0173377	A1 *	7/2007	Jamsen et al.	482/8
2003/0065257	A1 *	4/2003	Mault et al.	600/407	2008/0153671	A1 *	6/2008	Ogg et al.	482/3
2004/0046692	A1	3/2004	Robson et al.		2010/0190609	A1 *	7/2010	Shum et al.	482/8

* cited by examiner

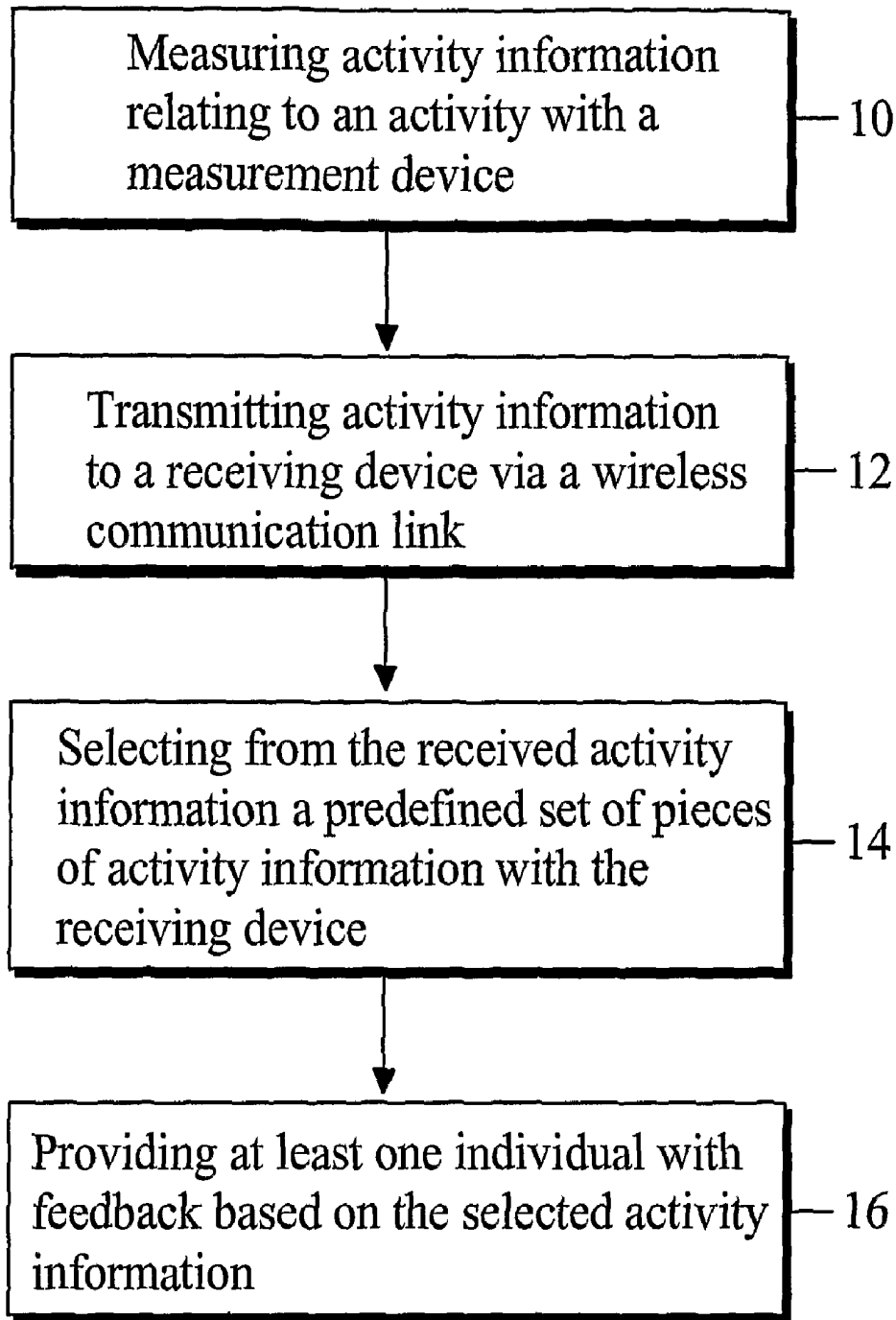

Fig. 1

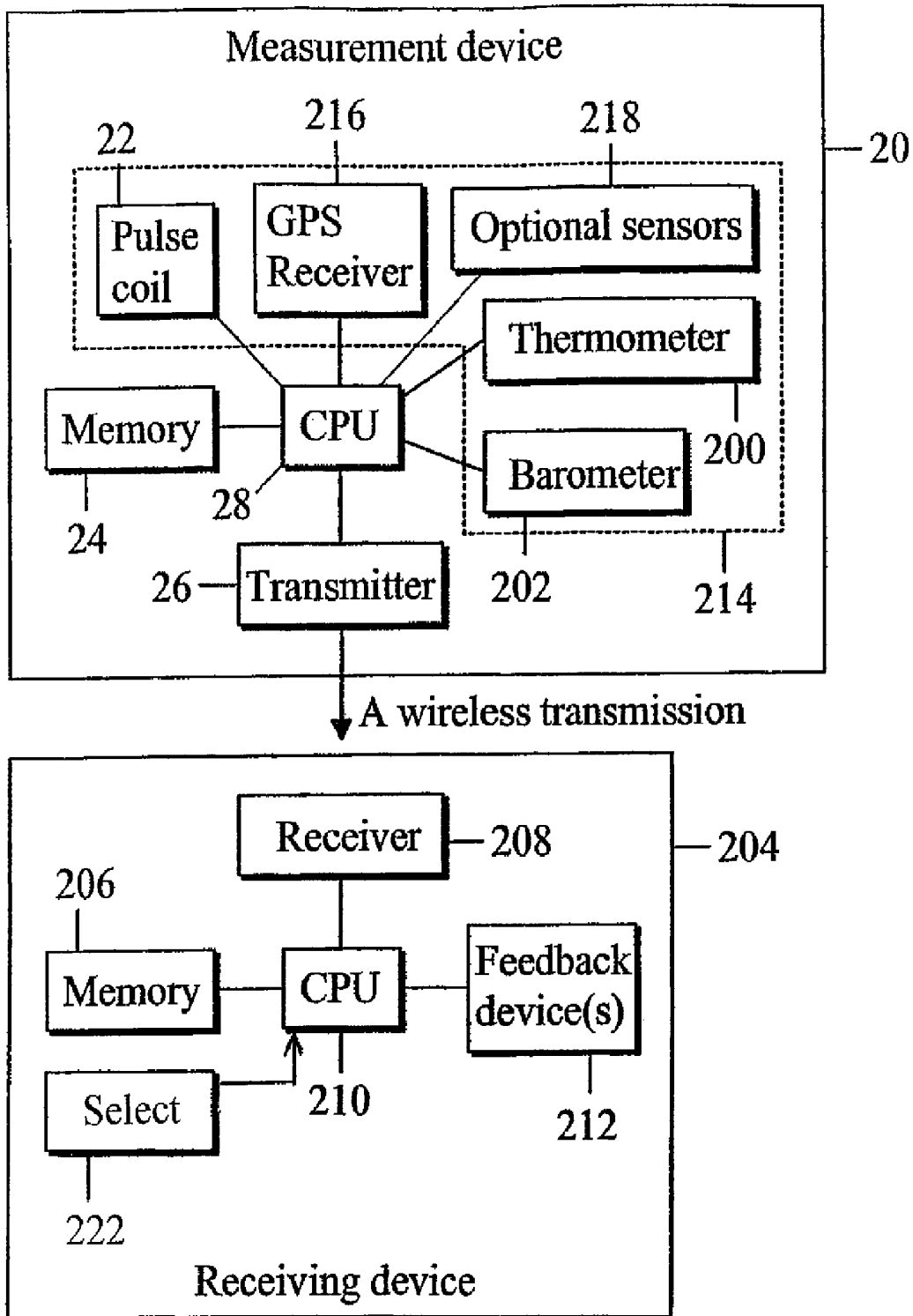

Fig. 2

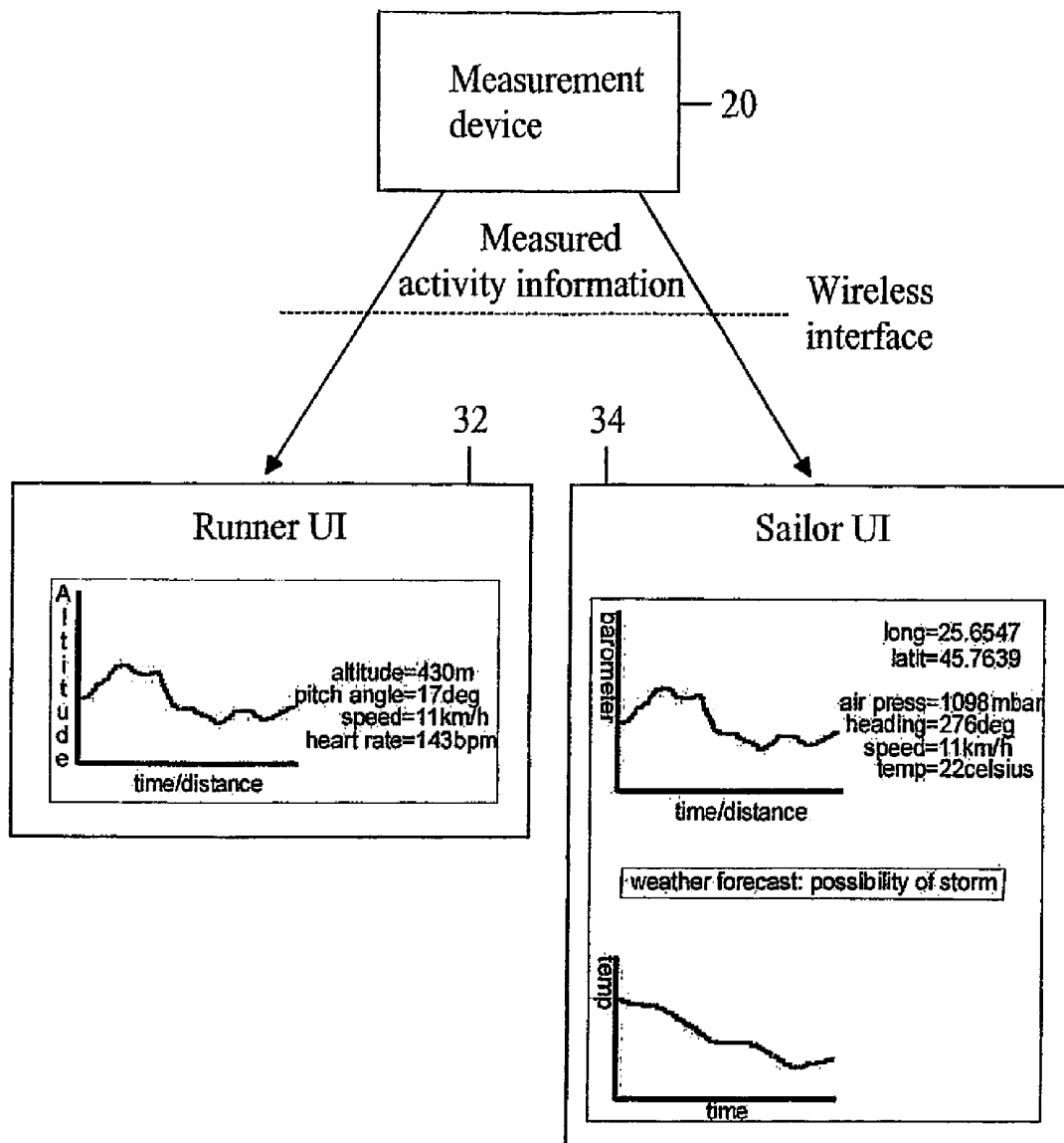

Fig. 3

**METHOD, SYSTEM, MEASUREMENT
DEVICE AND RECEIVING DEVICE FOR
PROVIDING FEEDBACK**

FIELD OF THE INVENTION

The present invention relates to providing feedback relating to an activity. In particular, the present invention relates to a novel and improved method, system, measurement device and receiving device for providing feedback relating to an activity to at least one individual.

BACKGROUND OF THE INVENTION

People have always been interested in how they perform in various tasks, e.g. in various sport events. Different manufacturers have provided various kinds of devices that can be used to analyze e.g. a sport event. These devices include e.g. a heart rate monitor, a wrist computer etc.

The Global Positioning System (GPS) provides a service in which by using a special GPS receiver position information can be acquired. The GPS uses a plurality of satellites to determine the position.

There exists a plurality of known solutions that use the GPS to record a path of an activity, e.g. a sport event. Such a data recorder can be afterwards connected to a computer and the performed path, e.g. a run path, can be displayed on a screen of the computer by connecting the recorded position points (coordinates). Furthermore, there exists known solutions that are able to record other quantities into memory of a measurement device. The quantities include e.g. a heart rate during an exercise, temperature etc.

One known solution uses a combination of a wristwatch and a heart rate belt display and/or record the heart rate data. The watch can be connected to a computer after the exercise, and based on the recorded heart rate data, a heart rate curve can be displayed to the user as a function of time. Furthermore, in other solutions it is possible e.g. to determine speed during a recorded path and the length of the recorded path based on the based on the position coordinates provided by the GPS receiver.

In some solutions, a current speed value and a distance travelled so far can be displayed using e.g. a wristwatch.

The problem with the current solutions is that every activity or sport needs a dedicated measurement device that can used to analyse performance.

SUMMARY OF THE INVENTION

According to one aspect of the invention there is provided a method of transmitting measured activity information and providing at least one individual with feedback based on the measured activity information. The method comprises the steps of measuring activity information relating to an activity of with a measurement device; transmitting activity information to a receiving device via a communication link; selecting from the received activity information a predefined set of pieces of activity information with the receiving device; and providing the at least one individual with feedback based on the selected activity information.

In one embodiment of the invention, the step of providing comprising providing the at least one individual at least one activity indicator based on the selected activity information with at least one feed-back device.

In one embodiment of the invention, prior to the step of providing the method further comprising the steps of calculating at least one additional activity indicator based on the at

least one selected activity information; and providing the at least one individual individual with the calculated at least one additional activity indicator with the at least one feedback device.

In one embodiment of the invention, the step of providing comprising presenting the at least one activity indicator to the at least one individual as at least one of a graphical form and voice signals.

In one embodiment of the invention, prior to the step of transmitting the method further comprising the step of calculating at least one additional piece of activity information based on the measured activity information.

In one embodiment of the invention, the step of transmitting comprising transmitting activity information according to a communication protocol.

In one embodiment of the invention, the step of providing comprising providing the at least one individual with feedback with the receiving device.

In one embodiment of the invention, the step of providing comprising providing the at least one individual with feedback with at least one device connected to the receiving device.

In one embodiment of the invention, the step of measuring comprising measuring at least one of the following quantities: time, location, altitude, temperature, and heart rate.

According to another aspect of the invention there is provided a measurement device configured to measure and transmit activity information. The measurement device comprises a processor; a plurality of measuring elements configured to measure a plurality of quantities relating to an activity; a memory configured to store measurement data provided by the measuring elements; and a transmitter configured to transmit activity information to at least one receiving device via a communication link according to a communication protocol.

In one embodiment of the invention, the plurality of measuring elements comprises at least one of the following: a GPS receiver, a barometer, a thermometer, and at least one pulse coil configured to measure heart rate.

In one embodiment of the invention, the processor is configured to calculate at least one additional piece of activity information based on the measured activity information; and the transmitter is configured to transmit the calculated activity information via a communication link.

According to another aspect of the invention there is provided a receiving device configured to receive activity information from a measurement device. The receiving device comprises a receiver configured to receive a transmission from the measurement device, wherein the transmission includes activity information measured with the measurement device; a memory configured to store at least one definition based on which a predefined set of pieces of activity information is selected from the received activity information; and a processor configured to select the predefined set of pieces of activity information from the received activity information based on the at least one definition stored on the memory.

In one embodiment of the invention, the receiving device further comprises at least one feedback device configured to provide at least one individual with feedback based on the selected activity information.

In one embodiment of the invention, the receiving device further comprises an output to which at least one feedback device can be connected.

In one embodiment of the invention, the at least one feedback device is configured to provide the at least one individual with at least one activity indicator based on the selected activity information.

In one embodiment of the invention, the processor is configured to calculate at least one additional piece of activity information based on the at least one selected activity information, and the at least one feedback device is configured to provide the at least one individual with the calculated at least one activity indicator.

In one embodiment of the invention, the at least one feedback device is configured to present the at least one activity indicator to the at least one individual as at least one of a graphical form and voice signals.

In one embodiment of the invention, the at least one feedback device comprises at least one of a display, a speaker and an earpiece.

According to another aspect of the invention there is provided a system of transmitting measured activity information and providing at least one individual with feedback based on the measured activity information. The system comprises a measurement device comprising a first processor, a plurality of measuring elements configured to measure a plurality of quantities relating to an activity, a first memory configured to store measurement data provided by the measuring elements, and a transmitter configured to transmit activity information to at least one receiving device via a communication link according to a communication protocol; and a receiving device comprising a receiver configured to receive a transmission from the measurement device, wherein the transmission includes activity information measured with the measurement device, a second memory configured to store at least one definition based on which a predefined set of pieces of activity information is selected from the received activity information, and a second processor configured to select the predefined set of pieces of activity information from the received activity information based on the at least one definition stored on the second memory; and at least one feedback device configured to provide the at least one individual with feedback based on the selected activity information.

In one embodiment of the invention, the plurality of measuring elements comprises at least one of the following: a GPS receiver, a barometer, a thermometer, and at least one pulse coil configured to measure heart rate.

In one embodiment of the invention, the first processor is configured to calculate at least one additional piece of activity information based on the measured activity information; and the transmitter is configured to transmit the calculated activity information via a communication link to the receiving device.

In one embodiment of the invention, the receiving device further comprises at least one feedback device configured to provide at least one individual with feedback based on the selected activity information.

In one embodiment of the invention, the receiving device further comprises an output to which at least one feedback device can be connected.

In one embodiment of the invention, the at least one feedback device is configured to provide the at least one individual with at least one activity indicator based on the selected activity information.

In one embodiment of the invention, the second processor is configured to calculate at least one additional piece of activity information based on the at least one selected activity information, and the at least one feedback device is configured to provide the at least one individual with the calculated at least one activity indicator.

In one embodiment of the invention, the at least one feedback device is configured to present the at least one activity indicator to the at least one individual as at least one of a graphical form and voice signals.

In one embodiment of the invention, the at least one feedback device comprises at least one of a display, a speaker and an earpiece.

The present invention has several advantages over the prior-art solutions. A benefit of the invention is that a single measurement device can be used to transmit all relevant information relating to an activity. The receiving device may then decide what pieces of activity information to use. Due to the aforementioned fact, device manufacturers are able to manufacture a variety of different receiving devices depending on the need and use of the device. All devices, however, receive the same transmission from the measurement device and are configured to give feedback to an individual or individuals (e.g. using a display of a device). For example, a cheap receiving device may display just basic feedback values to an athlete, whereas a more expensive receiving device may provide the athlete with a variety of pieces of performance information.

In other words, the invention provides a standard communication interface into which manufacturers of suitable equipment, e.g. wrist watches, mobile terminals, fixed sport stadium displays shall connect to.

BRIEF DESCRIPTION OF THE DRAWINGS

The accompanying drawings, which are included to provide a further understanding of the invention and constitute a part of this specification, illustrate embodiments of the invention and together with the description help to explain the principles of the invention. In the drawings:

FIG. 1 is a block diagram illustrating one embodiment of a method according to the invention,

FIG. 2 is a block diagram illustrating one embodiment of a system according to the invention, and

FIG. 3 illustrates one embodiment of possible user interfaces in receiving devices according to the invention.

DETAILED DESCRIPTION OF THE INVENTION

Reference will now be made in detail to the embodiments of the present invention, examples of which are illustrated in the accompanying drawings.

FIG. 1 is block diagram illustrating one embodiment of a method according to the invention. As indicated at step 10, activity information relating to an activity is measured with a measurement device. An activity may take any appropriate form, e.g. a run, a ski tour, sailing, cycling etc. A common feature to all these activities is that the user carries a measurement device. The measurement device may be attached to the user or it may alternatively be a stand-alone model. The measurement device measures and records a plurality of quantities, e.g. time, location, altitude, temperature and/or heart rate.

Activity information is then transmitted to a receiving device via a communication link, e.g. a wireless communication link, as indicated at step 12. The receiving device is e.g. a wristwatch, a display panel etc. The wireless communication link refers e.g. to a short-range wireless radio transmission. The receiving device is configured to select a predefined set of pieces of activity information from the transmission, as indicated at step 14. Based on the selected activity information, at least one individual is provided with feedback, as indicated at step 16. The at least one individual may be the aforementioned user himself/herself. In another embodiment, the receiving device may be connected to a separate feedback device or devices, e.g. to a scoreboard providing a plurality of individuals with feedback at the same time.

FIG. 2 is a block diagram illustrating one embodiment of a system according to the invention. The system of FIG. 2 comprises a measurement device 20 and a receiving device 204. FIG. 2 discloses only relevant elements and components of the measurement device 20 and receiving device in order to illustrate the invention. Therefore, it is evident that the devices may comprise also other elements and components not illustrated in FIG. 2.

Measurement device 20 is in one embodiment a device that can be attached e.g. to an arm of a user, e.g. an athlete. In other embodiments, it may be a stand-alone model that can be mounted to a desired place.

Measurement device 20 comprises a plurality of measuring elements 214. In this embodiment measuring elements 214 include a GPS receiver 216 configured to receive positioning information from a plurality of satellites, a pulse coil or pulse coils 22 configured to measure heart rate based on signals received e.g. from a pulse belt, a thermometer 200 configured to measure temperature and an barometer 202 configured to measure altitude. An element optional sensors 218 refers to any other optional sensor or sensors not disclosed above that can be incorporated into measurement device 20. Each measurement element is connected to a central processing unit 28. The measurement device 20 includes also a memory 24 connected to central processing unit 28. Memory 24 is configured to store measurements from the plurality of measuring elements 214. Furthermore, measurement device 20 includes a transmitter 26. Central processing unit 28 is configured to send with transmitter 26 a set of measured pieces of activity information from memory 24. Activity information refers mainly to measurement information provided by the plurality of measuring elements 214. Activity information may, however, comprise also information that has been calculated using central processing unit 28 based on the measurement results provided by the plurality of measuring elements 214. Such calculated values may include e.g. speed (calculated based on altitude and position information), pitch angle (calculated based on altitude and position information) etc.

The aforementioned activity information is arranged to a predefined form using a communication protocol. A frame of such a communication protocol typically comprises a header, at least one piece of activity information (measurement or calculated value), and a checksum. The communication protocol may also be an adaptive protocol. Any appropriate protocol may be used in the transmission. Transmitter 26 is configured to transmit data to a receiving device 204 via a wireless communication link. The wireless communication link refers e.g. to a short-range wireless radio transmission.

Receiving device 204 receives the transmission from transmitter 26 with a receiver 208. Receiving device 204 further includes a central processing unit 210, a memory 206 and a feedback device 212. Central processing unit 210 has a connection to each of receiver 208, memory 206 and feedback device 212. Memory 206 is configured to store at least one definition based on which a predefined set of pieces of activity information is selected from the received activity information from measurement device 20. Central processing unit 210 is configured to select (at 222) the predefined set of pieces of activity information from the received activity information based on the at least one definition stored on memory 206. Central processing unit 210 may in one embodiment also calculate at least one additional piece of activity information based on the at least one selected activity information. Such calculated values may include e.g. speed (calculated based on altitude and position information), pitch angle (calculated based on altitude and position information) etc.

Feedback device 212 is configured to provide the user of receiving device 204 with feedback based on the selected activity information. Feedback itself refers e.g. to a variety of activity indicators (speed, heart rate, altitude, air pressure temperature, position etc.). In one embodiment feedback is provided visually, i.e. feedback device 212 refers to a display. In another embodiment, feedback refers to sound signals, i.e. feedback device 212 refers e.g. to a speaker or an earpiece.

In FIG. 2 it is illustrated that feedback device 212 is a functional part of receiving device 204. In another embodiment of the invention, receiving device is configured to include an output to which at least one external feedback device may be connected. The output refers e.g. to a wireless or wired output interface towards an external feedback device or devices.

Receiving device 204 refers e.g. to a wristwatch, a display panel or any other type of feedback device that communicates with measurement device 20.

Although FIG. 2 discloses a specific set of measurement elements 214, it is evident that any one of the measuring elements 214 may be replaced with another appropriate element or, alternatively, any one of them may not have to be included in measurement device 20 at all.

FIG. 3 illustrates one embodiment of possible user interfaces in receiving devices according to the invention. Furthermore, FIG. 3 discloses a simplified embodiment that yet further illustrates the inventive idea of the invention.

FIG. 3 includes a measurement device 20 that was already discussed in more detail with FIG. 2. FIG. 3 further includes two different user interfaces, a runner user interface 32 and a sailor user interface 34. Runner user interface 32 is typically used in smaller devices, e.g. wristwatches etc. Sailor user interface 34 may be displayed on a larger display. Therefore, it can be used to convey more information to a user. The transmission of measured activity information via a wireless interface was also discussed in more detail with FIG. 2.

Runner user interface 32 shows basic values relating to an activity to the user. These basic values include e.g. altitude, pitch angle, speed and heart rate. Sailor user interface 34 displays more complex values to the user, e.g. longitude and latitude, air pressure, heading, speed, temperature, various graphs etc. It can be seen from FIG. 3 that, for example, information provided by a barometer can be used in different ways for different purposes or sports. A runner wants to see changes in air pressure by means of altitude changes, where as a sailor is also interested in the air pressure itself. Furthermore, air pressure in function of time can be used to forecast a possibility of a storm.

As a summary, FIG. 3 clarifies the fundamental inventive idea of the invention, which provides a standard wireless communication interface into which manufacturers of suitable equipment, e.g. wrist watches, mobile terminals, fixed sport stadium displays shall connect to. Furthermore the size, durability and usability of the user interface device (receiving device) can be designed according to the characteristic of the activity or sport in question.

It is obvious to a person skilled in the art that with the advancement of technology, the basic idea of the invention may be implemented in various ways. The invention and its embodiments are thus not limited to the examples described above, instead they may vary within the scope of the claims.

The invention claimed is:

1. A method for transmitting measured sports activity information and providing at least one individual with feedback based on the measured sports activity information, wherein the method comprises:

measuring sports activity information with a measurement device comprising a plurality of measuring elements connected to a processing unit;

transmitting, with the measurement device, the measured sports activity information to a receiving device via a short-range wireless radio communication link during the activity, wherein the receiving device provides different user interfaces in different sports or activities, according to the use or purpose of the information for the different sports or activities;

selecting, based on the sport in question, from the received sports activity information a predefined set of pieces of sports activity information with the receiving device based on at least one definition, stored in a memory, of a predefined set of pieces of activity information selected from the measured sports activity information; and

providing, through a standard communication interface connection, with the receiving device on a user interface display selected based on the sport in question, the at least one individual with feedback based on the selected sports activity information, wherein, in the case of at least one activity, the user interface display comprises activity-specific information according to the sport in question and comprising geophysical data selected from at least one of a group consisting of longitude and latitude, air pressure, heading, speed, temperature and graphical information, whereby the standard communication interface provides a capability to provide said display size, durability and usability according to the characteristic of said one activity.

2. The method according to claim 1, wherein said providing step comprises providing the at least one individual at least one sports activity indicator based on the selected sports activity information with at least one feedback device.

3. The method according to claim 2, wherein prior to said providing step the method further comprises:

- calculating at least one additional sports activity indicator based on the at least one selected sports activity information; and
- providing the at least one individual with the calculated at least one additional sports activity indicator with the at least one feedback device.

4. The method according to claim 2, wherein said providing step comprises presenting the at least one sports activity indicator to the at least one individual as at least one of a graphical form and voice signals.

5. The method according to claim 1, wherein prior to said transmitting step the method further comprises:

- calculating at least one additional piece of sports activity information based on the measured sports activity information.

6. The method according to claim 1, wherein said transmitting step comprises transmitting sports activity information according to a communication protocol.

7. The method according to claim 1, wherein said providing step comprises providing the at least one individual with feedback with the receiving device.

8. The method according to claim 1, wherein said providing step comprises providing the at least one individual with feedback with at least one device connected to the receiving device.

9. The method according to claim 1, wherein said measuring step comprises measuring at least one of the following quantities:

- time;
- location;
- altitude;

temperature; and
heart rate.

10. The method according to claim 1, wherein the receiving device is carried by the at least one individual.

11. The method according to claim 1, wherein the receiving device comprises stored in its memory at least one definition based on which the predefined set of pieces is selected from the received sports activity information.

12. The method according to claim 1, wherein the sports activity information provided by the measurement device, such as information provided by a barometer, is used in different ways for different sports.

13. The method of claim 1, further comprising providing a standard wireless communication interface for the receiving device to connect to.

14. A measurement device configured to measure and transmit sports activity information, wherein the measurement device comprises:

- a processor;
- a plurality of measuring elements configured to measure a plurality of quantities relating to a sports activity according to the use or purpose of the information for the sports activity, wherein the plurality of measuring elements comprise at least one of the following:

- a GPS receiver;

- a barometer;

- a thermometer; and

- at least one pulse coil configured to measure heart rate;

- a memory configured to store measurement data provided by the measuring elements;

- a transmitter configured to transmit sports activity information via a short-range wireless radio communication link during the sports activity according to a communication protocol, said transmission of sports activity information subject to a selection by a receiving device based on the sport in question, to at least one receiving device based on at least one definition, stored in the memory, of a predefined set of pieces of activity information selected from the measured sports activity information, wherein, in the case of at least one activity, transmission of sports activity specific to the sport in question comprises activity-specific information comprising geophysical data selected from at least one of a group consisting of longitude and latitude, air pressure, heading, speed, temperature and graphical information; and

- a user interface display interface including a standard communication interface connection, permitting connection to a user interface display selected based on the sport in question, thereby providing a capability to provide said display size, durability and usability according to the characteristic of said one activity.

15. The measurement device according to claim 14, wherein the processor is configured to calculate at least one additional piece of sports activity information based on the measured sports activity information; and the transmitter is configured to transmit the calculated sports activity information via a communication link.

16. A receiving device configured to receive sports activity information from a measurement device, wherein the receiving device comprises:

- a receiver configured to receive, during a sports activity, a transmission from the measurement device via a short-range wireless radio communication link, wherein the transmission includes sports activity information measured with the measurement device, and the receiver provides different user interfaces in different sports or

activities, according to the use or purpose of the information for the different sports or activities, wherein, in the case of at least one activity, the transmission includes sports activity information comprises activity-specific information comprising geophysical data selected from at least one of a group consisting of longitude and latitude, air pressure, heading, speed, temperature and graphical information;

a memory configured to store at least one definition, based on which a predefined set of pieces of sports activity information is selected from the received sports activity information according to the use or purpose of the information for the sports activity;

a processor configured to select the predefined set of pieces of sports activity information from the received sports activity information based on the at least one definition, which is defined based on the sport in question, stored on the memory and connected through a standard communication interface connection; and

at least one feedback device connected to the standard communication interface connection and configured to provide at least one individual with feedback on a user interface display based on the selected sports activity information, whereby the standard communication interface provides a capability to provide said display size, durability and usability according to the characteristic of said one activity.

17. The receiving device according to claim 16, wherein the receiving device further comprises an output to which at least one feedback device can be connected.

18. The receiving device according to claim 16, wherein the at least one feedback device is configured to provide at least one individual with at least one sports activity indicator based on the selected sports activity information.

19. The receiving device according to claim 16, wherein the processor is configured to calculate at least one additional piece of sports activity information based on the at least one selected sports activity information, and the at least one feedback device is configured to provide the at least one individual with the calculated at least one sports activity indicator.

20. The receiving device according to claim 16, wherein the at least one feedback device is configured to present the at least one sports activity indicator to the at least one individual as at least one of a graphical form and voice signals.

21. The receiving device according to claim 16, wherein the at least one feedback device comprises at least one of a display, a speaker and an earpiece.

22. A system of transmitting measured sports activity information and providing at least one individual with feedback based on the measured sports activity information, wherein the system comprises:

a measurement device comprising a first processor, a plurality of measuring elements configured to measure a plurality of quantities relating to a sports activity, a first memory configured to store measurement data provided by the measuring elements, and a transmitter configured to transmit sports activity information during the sports activity, according to the use or purpose of the information for the different sports activity, to at least one receiving device based on at least one definition, stored in a memory, of a predefined set of pieces of activity information selected from the measured sports activity information, via a local communication link according to a communication protocol, wherein the plurality of measuring elements comprise at least one of the following:

- a GPS receiver;
- a barometer;

- a thermometer; and
- at least one pulse coil configured to measure heart rate; and the receiving device comprising a receiver configured to receive a transmission from the measurement device during the sports activity via a short-range wireless radio communication link, wherein the transmission includes sports activity information measured with the measurement device, a second memory configured to store at least one definition based on which a predefined set of pieces of sports activity information is selected from the received sports activity information, and a second processor configured to select the predefined set of pieces of sports activity information from the received sports activity information based on the at least one definition, which is defined based on the sport in question, stored on the second memory; and at least one feedback device, connected through a standard communication interface connection, configured to provide the at least one individual with feedback on a user interface display based on the selected sports activity information, wherein, in the case of at least one activity, the user interface display comprises activity-specific information comprising geophysical data selected from at least one of a group consisting of longitude and latitude, air pressure, heading, speed, temperature and graphical information, whereby the standard communication interface provides a capability to provide said display size, durability and usability according to the characteristic of said one activity.

23. The system according to claim 22, wherein the first processor is configured to calculate at least one additional piece of sports activity information based on the measured sports activity information; and the transmitter is configured to transmit the calculated sports activity information via a communication link to the receiving device.

24. The system according to claim 22, wherein the receiving device further comprises an output to which at least one feedback device can be connected.

25. The system according to claim 22, wherein the at least one feedback device is configured to provide at least one individual with at least one sports activity indicator based on the selected sports activity information.

26. The system according to claim 22, wherein the second processor is configured to calculate at least one additional piece of sports activity information based on the at least one selected sports activity information, and the at least one feedback device is configured to provide the at least one individual with the calculated at least one sports activity indicator.

27. The system according to claim 22, wherein the at least one feedback device is configured to present the at least one sports activity indicator to the at least one individual as at least one of a graphical form and voice signals.

28. The system according to claim 22, wherein the at least one feedback device comprises at least one of a display, a speaker and an earpiece.

29. Apparatus for providing at least one individual with feedback based on the measured sports activity information, the apparatus comprising:

means for measuring sports activity information with a measurement device comprising a plurality of measuring elements connected to a processing unit, the plurality of measuring elements comprising at least one of the following:

- a GPS receiver;
- a barometer;
- a thermometer; and
- at least one pulse coil configured to measure heart rate;

11

means, comprising a short-range radio communication link, for transmitting the measured sports activity information to a receiving device according to the use or purpose of the information for the sports activity, by transmitting the measured sports activity via the short-range wireless radio communication link during the activity; 5
means for selecting, based on the sport in question, from the received sports activity information a predefined set of pieces of sports activity information with the receiving device; and 10
means, comprising a standard communication interface connection, for providing, with the receiving device on a

12

user interface display, the at least one individual with feedback based on the selected sports activity information, wherein, in the case of at least one activity, the user interface display comprises activity-specific information comprising geophysical data selected from at least one of a group consisting of longitude and latitude, air pressure, heading, speed, temperature and graphical information, whereby the standard communication interface provides a capability to provide said display size, durability and usability according to the characteristic of said one activity.

* * * * *

专利名称(译)	用于提供反馈的方法，系统，测量设备和接收设备		
公开(公告)号	US8088042	公开(公告)日	2012-01-03
申请号	US10/581314	申请日	2004-12-07
[标]申请(专利权)人(译)	LIMMA伊尔卡 KAMPMAN VILLE MOILANEN哈努		
申请(专利权)人(译)	LIMMA伊尔卡 KAMPMAN VILLE MOILANEN哈努		
当前申请(专利权)人(译)	ELISA OYJ		
[标]发明人	LIMMA ILKKA KAMPMAN VILLE MOILANEN HANNU		
发明人	LIMMA, ILKKA KAMPMAN, VILLE MOILANEN, HANNU		
IPC分类号	A63B71/00 A61B5/00 A61B5/024 A61B5/11 G01M99/00		
CPC分类号	A61B5/1112 A61B5/1118 A61B5/002 A61B5/0008 A61B5/02438 A61B2560/0242 Y10S482/901 A61B2503/10		
优先权	2003001777 2003-12-05 FI		
其他公开文献	US20080108481A1		
外部链接	Espacenet USPTO		

摘要(译)

一种用于向至少一个人提供与活动有关的反馈的方法，系统，测量设备和接收设备。在该方法中，利用测量装置测量与活动有关的活动信息。活动信息通过通信链路发送到接收设备。接收设备从所接收的活动信息中选择预定义的一组活动信息，并基于所选择的反馈信息向所述至少一个人提供反馈。

