



US007648475B2

(12) **United States Patent**
De Cicco et al.

(10) **Patent No.:** **US 7,648,475 B2**
(45) **Date of Patent:** **Jan. 19, 2010**

(54) **NON-INVASIVE DEVICE FOR MEASURING BLOOD TEMPERATURE IN A CIRCUIT FOR THE EXTRACORPOREAL CIRCULATION OF BLOOD, AND EQUIPMENT PROVIDED WITH THIS DEVICE**

(75) Inventors: **Giorgio De Cicco**, Modena (IT); **Francesco Fontanazzi**, Modena (IT); **Annalisa Delnevo**, Sant'Agata Bolognese (IT); **Massimo Zaccarelli**, San Felice sul Panaro (IT); **Francesco Paolini**, Ganaceto (IT)

(73) Assignee: **Gambro Lundia AB** (SE)

(*) Notice: Subject to any disclaimer, the term of this patent is extended or adjusted under 35 U.S.C. 154(b) by 787 days.

(21) Appl. No.: **10/500,336**

(22) PCT Filed: **Dec. 20, 2002**

(86) PCT No.: **PCT/IB02/05572**

§ 371 (c)(1),
(2), (4) Date: **Jun. 28, 2004**

(87) PCT Pub. No.: **WO03/055544**

PCT Pub. Date: **Jul. 10, 2003**

(65) **Prior Publication Data**

US 2005/0094704 A1 May 5, 2005

(30) **Foreign Application Priority Data**

Dec. 28, 2001 (IT) MI2001A2828

(51) **Int. Cl.**

A61M 37/00 (2006.01)
A61M 31/00 (2006.01)

A61M 1/00 (2006.01)
C02F 1/00 (2006.01)
(52) **U.S. Cl.** **604/4.01**; 604/5.01; 604/6.09; 604/65; 604/67; 422/44; 210/742; 210/741
(58) **Field of Classification Search** 604/4.01, 604/5.01, 6.11, 6.14, 609, 65, 67, 6.13, 28; 422/1, 4, 44, 45, 46, 48; 210/742, 741, 143, 210/86, 87; 417/2-6, 18-22, 42, 43, 44.1
See application file for complete search history.

(56) **References Cited**

U.S. PATENT DOCUMENTS

4,091,672 A 5/1978 Amrine et al.

(Continued)

FOREIGN PATENT DOCUMENTS

EP 0 231 652 A2 8/1987

(Continued)

Primary Examiner—Jacqueline F. Stephens

(74) *Attorney, Agent, or Firm*—Finnegan, Henderson, Farabow, Garrett & Dunner L.L.P.

(57) **ABSTRACT**

A non-invasive device for measuring blood temperature in a circuit for the extracorporeal circulation of blood includes a line in which blood taken from a patient flows. The device also includes a temperature sensor connected to the line and provided with a device for measuring the intensity of an electromagnetic radiation. The measuring device faces a connecting portion or window of the line that is permeable by electromagnetic radiation in a first wave band, and generates a first signal, correlated with the electromagnetic radiation in the first band and therefore with the temperature of the blood flowing in the line.

28 Claims, 3 Drawing Sheets

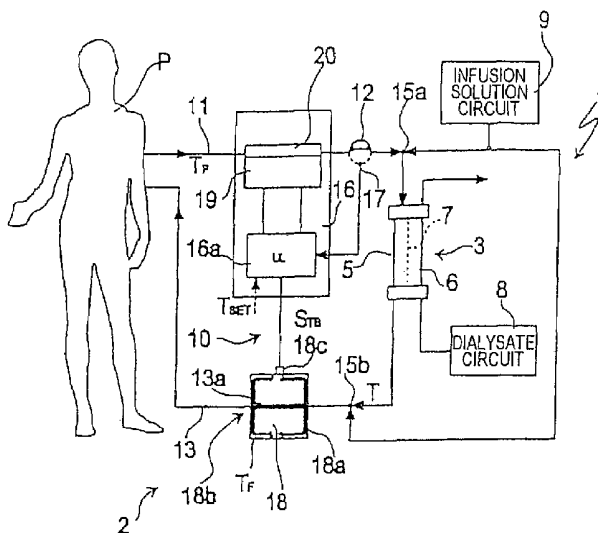

US 7,648,475 B2

Page 2

U.S. PATENT DOCUMENTS			FOREIGN PATENT DOCUMENTS		
4,243,883	A	1/1981 Schwarzmann	EP	0 720 013	A2 7/1996
4,444,498	A	4/1984 Heinemann	EP	1 132 101	A1 9/2001
4,774,415	A	9/1988 Biegel et al.	JP	3-273689	12/1991
4,894,164	A	1/1990 Polaschegg	JP	9-257584	10/1997
5,150,969	A	9/1992 Goldberg et al.	JP	2000-186963	7/2000
5,154,512	A	10/1992 Schietinger et al.	JP	2000-214083	8/2000
5,180,896	A	1/1993 Gibby et al.	JP	2001-349783	12/2001
5,211,626	A	5/1993 Frank et al.	WO	WO 92/13482	8/1992
5,261,874	A	11/1993 Castle	WO	WO 93/06775	4/1993
5,539,673	A	7/1996 Charm et al.	WO	WO 93/23747	11/1993
5,588,959	A	12/1996 Ahmad et al.	WO	WO 94/01749	1/1994
5,615,672	A	4/1997 Braig et al.	WO	WO 94/12859	6/1994
6,283,632	B1	9/2001 Takaki	WO	WO 94/27495	12/1994
6,439,577	B2	8/2002 Jorgensen et al.	WO	WO 95/04266	2/1995
			WO	WO 96/04535	2/1996
			WO	WO 98/38953	9/1998
			WO	WO 98/52629	11/1998
			WO	WO 01/33214	A2 5/2001
EP	0 364 579	A1 4/1990	WO	WO 01/33214	A3 5/2001

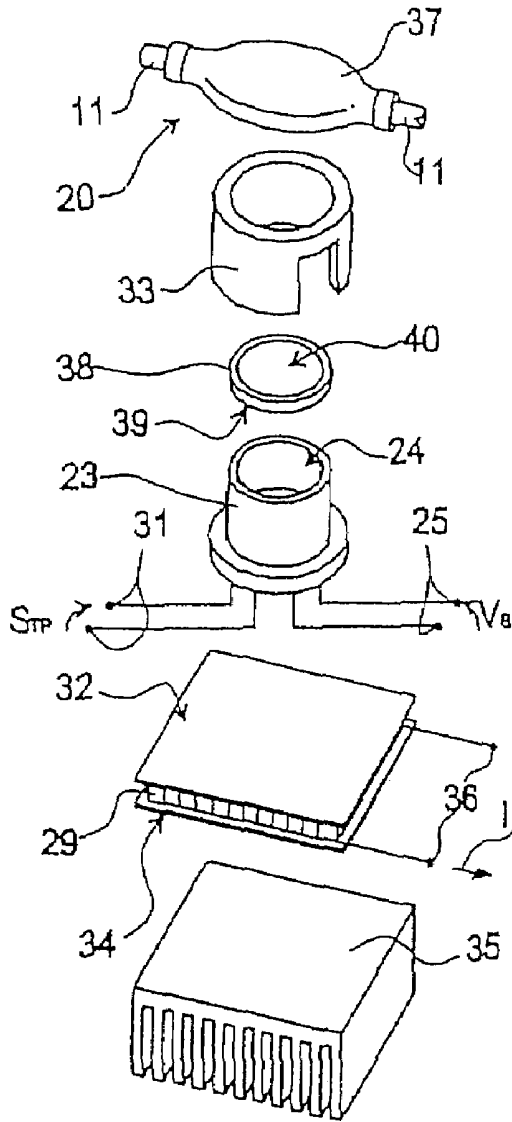

Fig. 3

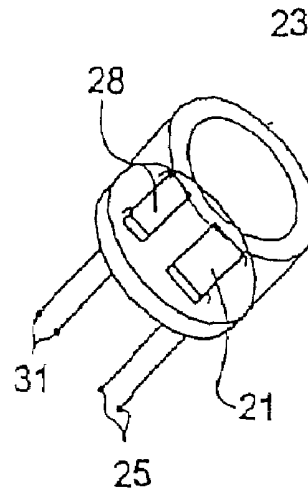

Fig. 4

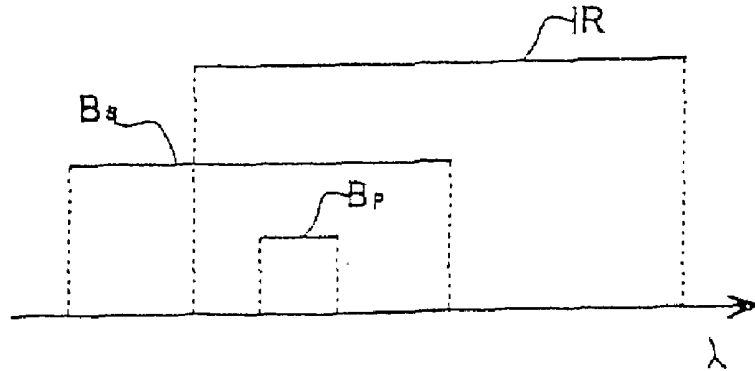

Fig. 5

**NON-INVASIVE DEVICE FOR MEASURING
BLOOD TEMPERATURE IN A CIRCUIT FOR
THE EXTRACORPOREAL CIRCULATION OF
BLOOD, AND EQUIPMENT PROVIDED WITH
THIS DEVICE**

The present invention relates to a non-invasive device for measuring blood temperature in a circuit for the extracorporeal circulation of blood, and to equipment provided with this device.

It is known that one of the problems closely associated with the use of circuits for the extracorporeal circulation of blood is that of monitoring the blood temperature. This is because the human body maintains the blood temperature at an essentially constant level of approximately 37° C., with very limited variations contained within a few tenths of a degree Celsius (in non-pathological conditions). Larger variations can result in an imbalance in the body, causing damage which may be severe. However, during its extracorporeal circulation, the blood gives up some of its heat to the surrounding environment, and this may result in excessive and prolonged lowering of the blood temperature, such that metabolic imbalance is caused, especially in vulnerable patients.

Special arrangements must therefore be made for certain types of machines, such as dialysis machines, which use a circuit for extracorporeal circulation. Dialysis treatments have to be repeated frequently and for prolonged periods, and it is therefore particularly important to protect the patient from the risks described above. Moreover, a dialysis machine uses a filter having a first compartment, in which the blood flows, and a second compartment, in which there flows a dialysate which may be at a temperature different from the blood temperature. The two compartments are separated from each other by a semi-permeable membrane which allows heat to be transferred from the blood to the dialysate and vice versa. For this reason also, the problem of monitoring the blood temperature is very important in the field of dialysis machines. Similar problems arise when haemofiltration and haemodiafiltration treatments are carried out.

Various methods have been proposed for monitoring the blood temperature during extracorporeal circulation, the efficacy of these methods being dependent on the possibility of measuring in a precise and rapid way the patient's blood temperature immediately downstream of the collection point and upstream of the return point. This temperature is measured indirectly by means of a non-invasive measurement system comprising a temperature sensor connected to a portion of the extracorporeal circuit. In greater detail, in known measurement systems a portion of a line of the extracorporeal circuit is housed in an aluminium element shaped in such a way that it has a large heat exchange surface in contact with the said line. A platinum thermistor is placed in contact with the aluminium element and is used to measure the temperature of the latter. In conditions of thermal equilibrium, the temperature of the line and therefore of the blood flowing in it is related to the temperature of the aluminium element by a known relation and can be determined from the signal supplied by the thermistor. In order to reduce the effect of the external environment on the result of the measurement, the transducer formed in this way (the aluminium element and the thermistor) is inserted into a support, also made from aluminium, which is kept at the same temperature as the line by a heater controlled by a suitable control unit. Thus the heat exchange between the transducer and the external environment is minimized, and the measured temperature depends solely on the heat exchange with the line. The space between the transducer and the heated support is filled with a material (for example, PVC) chosen in such a way as to optimize the compromise between the speed of response of the sensor and the thermal insulation from the external environment.

However, the known systems have a number of drawbacks. This is because the lines forming the extracorporeal circuit are normally made from material with low thermal conductivity, in order to prevent a damaging loss of heat. The thermal coupling between the blood flowing within the extracorporeal circuit and the aluminium element is therefore poor, and the measurement made in the way that has been described is inevitably of low accuracy. In particular, the known systems have very long response transients, since a variation in blood temperature is detected only after a new state of thermal equilibrium has been established among the blood flow, the wall of the extracorporeal circuit, the transducer and the heated support.

The object of the present invention is to provide a non-invasive device for measuring the blood temperature in a circuit for the extracorporeal circulation of blood, which is free of the drawbacks of the known art.

According to the present invention, a non-invasive device is provided for measuring blood temperature in a circuit for the extracorporeal circulation of blood, this device comprising a line in which blood taken from a patient flows, and a temperature sensor, connected to the said line and generating a first signal correlated with the temperature of the blood flowing in the said line, characterized in that the said temperature sensor comprises a device for measuring the intensity of an electromagnetic radiation, and the said line comprises a connecting portion facing the said measuring device and permeable by electromagnetic radiation in a first wave band; the said first signal being correlated with the intensity of the said electromagnetic radiation in the said first band.

The device according to the invention advantageously permits the measurement of a quantity directly correlated with the patient's blood temperature, namely the electromagnetic radiation emitted by the blood at a certain temperature in a predetermined frequency band. Secondly, the portion of the extracorporeal circuit on which the measurement is made is connected to the sensor in such a way that the fraction of electromagnetic radiation emitted by the blood and incident on the measuring device is maximized. Furthermore, the devices for measuring electromagnetic radiation, comprising a thermopile in a preferred embodiment of the invention, have very short response transients. The device therefore has very high precision, accuracy and speed of response. In practice, the blood temperature can be measured with an error of less than 0.1° C. and with transients of the order of hundredths of a second.

The present invention also relates to control equipment in an extracorporeal blood circuit, as specified in claim 20.

To enable the present invention to be more clearly understood, a preferred embodiment thereof will now be described, purely by way of example and without restrictive intent, with reference to the attached figures, of which:

FIG. 1 is a schematic view, with parts removed for clarity, of a dialysis machine equipped with a blood temperature measuring device constructed according to the present invention;

FIG. 2 is a schematic view in side elevation of the measuring device of FIG. 1,

FIG. 3 is an exploded view of the device of FIG. 1, with parts removed for clarity;

FIG. 4 is a perspective view of a detail of the device of FIG. 3;

FIG. 5 is a graph showing characteristics of parts of the device of FIG. 2;

FIG. 6 is a partial schematic view of the detail of FIG. 4; and

FIG. 7 is a schematic view, with parts removed for clarity, of a dialysis machine equipped with a blood temperature measuring device constructed according to a variant of the present invention.

In the example of embodiment described below, the invention is used for monitoring the blood temperature during a dialysis treatment.

In FIG. 1, the number 1 indicates the whole of a dialysis machine connected to a patient P. The machine 1 comprises an extracorporeal blood circuit 2, a filter 3 including a blood compartment 5 and a dialysate compartment 6 separated by a semi-permeable membrane 7, a dialysate circuit 8 connected to the dialysate compartment 6, an infusion circuit 9 and equipment 10 for regulating the blood temperature.

The extracorporeal blood circuit 2 comprises an arterial branch 11, in which a peristaltic pump 12 is located, and a venous branch 13. The arterial branch 11 has one end connected to the blood compartment 5 and one end connected to a fistula (not illustrated) in the patient P to collect the blood from the cardiovascular system of the patient P, while the venous branch 13 has one end connected to the blood compartment 5 and an opposite end fitted into the aforesaid fistula (not illustrated) to return the treated blood to the cardiovascular system of the patient P. The branches 11 and 13 are tubes made from plastic material, used, respectively, for supplying the blood to be treated to the compartment 5 and for introducing into the cardiovascular system the treated blood leaving the compartment 5.

The infusion circuit 9 is connected to a pre-dilution node 15a, located in the arterial branch 11, and to a post-dilution node 15b, located in the venous branch 13, and supplies a controlled quantity of an infusion solution to the extracorporeal circuit 2, in a known way. Alternatively, the infusion circuit 9 is connected only to the pre-dilution node 15a or only to the post-dilution node 15b.

The equipment 10 for regulating the blood temperature comprises a non-invasive device 16 for measuring the blood temperature, located in the arterial branch 11 and provided with a control unit 16a, a state sensor 17 for detecting whether the peristaltic pump 12 is in operation, and a temperature regulating device 18, located in a portion 13a of the venous branch 13 of the extracorporeal circuit 2 downstream of the post-dilution node 15b, in such a way that it combines with the portion 113a to form a heat exchanger. The regulating device 18 is also connected to an output of the device 16 supplying a blood temperature signal S_{TB} .

The device 18 regulates the blood temperature in the portion 13a without adding mass to the blood flow. In other words, the regulating device 18 acts on a fluid which is separated physically from the blood and whose temperature T_F is monitored by the unit 16a in a range from 20° C. to 43° C. in such a way as to supply heat to, or remove it from, the blood flowing in the venous branch 13 directly before the blood is returned to the patient P.

The regulating device 18 comprises at least one line 18a, which forms a set of windings or a nest of tubes and provides a seat 18b for housing the portion 13a of the venous branch 13, and a heater/cooler 18c connected to the control unit 16a.

During operation, in the course of the dialysis treatment the blood is collected from the patient P and is conveyed along the extracorporeal circuit 2. The non-invasive device 16 measures the temperature T_P and the control unit 16a controls the regulating device 18, on the basis of a predetermined algorithm, as a function of the temperature T_P and a reference temperature T_{SET} which is set by an operator at the control unit 16a.

For example, the control unit 16a compares the temperature T_P with the reference temperature T_{SET} , which is generally 37° C., and calculates the temperature difference ΔT between the temperature T_P and the reference temperature T_{SET} . At the start of the dialysis treatment, the regulating device 18 keeps the temperature T_F of the fluid at a value equal to the reference temperature T_{SET} , while the temperature T_D of the dialysate is regulated in such a way as to

optimize the haemodialysis treatment. During the haemodialysis treatment, the blood temperature T in the extracorporeal circuit 2 varies as a result of the heat exchange with the surrounding environment, with the dialysate, and with the fluid conveyed within the regulating device 18, and as a function of the reaction of the patient P to the materials used in the treatment of the blood.

The temperature T_P is measured by the non-invasive device 16, for example, at relatively short time intervals during the dialysis treatment, and the control unit 16a calculates the temperature difference ΔT at the same frequency as that of the measurement of the temperature T_P . When the temperature difference ΔT between the temperature T_P and the reference temperature T_{SET} takes a negative value, the fluid temperature T_F is increased in such a way as to supply heat to the blood in the portion 13a, while when the temperature difference ΔT takes a positive value the fluid temperature T_F is reduced in such a way as to remove heat from the blood in the portion 13a. The repetition of the procedure described above at short time intervals makes it possible to rapidly stabilize the temperature T_P , in other words the temperature of the patient P, at a value close to the reference temperature T_{SET} whenever the temperature T_P varies with respect to the reference temperature T_{SET} .

The sensor 17 detects the state of operation of the pump 12 and emits a signal to indicate when the pump 12 is operational and when it is stopped. If the signal emitted by the sensor 17 indicates that the pump 12 is in a stopped state, the control unit 16a keeps the value of T_F equal to the reference temperature T_{SET} ; if, on the other hand, the signal indicates that the pump 12 is in an operational state, the fluid temperature T_F is regulated as a function of the temperature difference ΔT according to the procedure described above.

In a variant of the operation, the reference temperature T_{SET} is not fixed, but varies during the dialysis-treatment according to a specified profile.

As illustrated in FIGS. 2 and 3, the device 16 comprises a temperature sensor 19, a line 20 fitted in the arterial branch 11 and connected to the sensor 19, and the digital and/or analogue control unit 16a.

In greater detail, the sensor 19 comprises a thermopile 21 and a temperature control device 22. The thermopile 21 is housed within a casing 23 (FIG. 4), in a window 24 formed in the said casing 23, and has a pair of measuring terminals 25 connected to the control unit 16a. Between these terminals 25 there is a voltage V_B correlated with the intensity of the electromagnetic radiation striking the thermopile 21 through the window 24 and having a predetermined measurable waveband B_S , at least partially included in the infrared band IR (FIG. 5). The operating principle of a thermopile is based on the Seebeck effect. In particular, the thermopile 21 preferably has a plurality of hot junctions 21a and cold junctions 21b connected together in series, as shown in FIG. 6. The hot junctions 21a are located in an area of absorption 21c which absorbs the incident electromagnetic radiation and modifies its own temperature as a result. The cold junctions 21b are supported by a support 21d of semiconductor material placed in contact with the casing 23 (FIG. 4) in which the thermopile 21 is housed. The voltage V_B generated by the thermoelectric effect is a function of the temperature difference between the hot junctions 21a and the cold junctions 21b, in other words between the absorption area 21c and the support 21d. In order to have a voltage V_B which is different from zero and dependent solely on the intensity of the electromagnetic radiation, and in order to have a high signal-to-noise ratio as well, the temperature of the support 21d, on which the cold junctions 21b are located, must be kept at a value sufficiently lower than the operating temperature range within which the thermopile 21 is to be used. For this purpose, use is made of the control device 22 which keeps the casing 23 and consequently the

support **21d** at a controlled and constant operating temperature, in the range from 5° C. to 15° C. and preferably at 10° C. With reference to FIGS. 2-4, the control device **22** comprises a thermistor **28** (FIG. 4), a solid-state heat pump **29** and a control circuit **30**, preferably integrated in the control unit **16a** (FIG. 2). The thermistor **28** is located within the casing **23** and is thermally connected to the cold junctions **21b** of the thermopile **21** by means of the casing **23** and the support **21d**; additionally, the thermistor **28** has a pair of terminals **31** connected to the control circuit **30** and supplying an electrical signal S_{TP} , correlated with the operating temperature of thermopile **21**. The heat pump **29** is a thermoelectric module, for example a Peltier cell, which causes heat to be transferred between its two opposite surfaces when an electrical current passes through it, and therefore has a cold surface **32** and a hot surface **34** (FIGS. 2 and 3). The cold surface **32** is connected to the casing **23** of the thermopile **21** by means of a heat-conducting support **33** (made from copper, for example), which is pierced so that it can house the thermopile **21**. The hot surface **34** is connected to a heat sink **35** to promote the dispersion of the heat extracted by the said heat pump **29**. The heat pump **29** also has a pair of terminals **36** connected to the control circuit **30**, which, in a known way, supplies a control current I_C correlated with the electrical signal S_{TP} .

As shown in FIGS. 2 and 3, the line **20**, in which the blood collected from the patient P flows, comprises a connecting portion **37**, facing the thermopile **21** and permeable by the electromagnetic radiation in the measurable band B_S . In greater detail, the connecting portion **37** is of discoid shape and is completely superimposed on the window **24** of the casing **23** in which the thermopile **21** is housed, in such a way that it completely covers the solid angle of view of the thermopile **21**. Additionally, the connecting portion **37** is made from a material having negligible absorbance and high transmittance in the measurable band B_S and in a temperature range from 30° C. to 40° C. Preferably, this material is chosen from high-density polyethylene, low-density polyethylene and poly(4-methyl-1-pentene) (PMP). Thus the fraction of electromagnetic radiation emitted by the blood of the patient P in the temperature range from 30° C. to 40° C. and striking the thermopile is maximized.

A filter **38**, comprising a sheet of a material which is essentially opaque to electromagnetic radiation outside a pass band B_P lying within the measurable band B_S (FIG. 5), is interposed between the thermopile **21** and the line **20** (FIGS. 2 and 3). In particular, the filter **38** is supported by the casing **23**, and has a first face **39** positioned so that it covers the window **24**, and a second face **40**, opposite the first face **39** and facing the connecting portion **37** of the line **20**. In the embodiment of the invention described herein, the filter **38** is made from suitably treated germanium, and the pass band B_P is in the range from 8 μm to 14 μm (infrared).

During the dialysis treatment, the blood collected from the cardiovascular system of the patient P flows through the line **20** and emits electromagnetic radiation in the measurable band B_S . A fraction of the electromagnetic radiation emitted through the filter **38** and the window **24** strikes the thermopile **21**, thus contributing to the determination of the value of the voltage V_B between the terminals **25**. In greater detail, the variations of the voltage V_B are due exclusively to the variations of intensity of the electromagnetic radiation which is emitted by the blood flowing in the connecting portion **37** and which strikes the thermopile **21**. This is because, since the connecting portion **37** is positioned so that it entirely covers the solid angle of view of the thermopile **21** through the window **24**, the flow of electromagnetic radiation through the window **24** is essentially due solely to the electromagnetic radiation emitted by the blood flowing in the connecting portion **37**; additionally, the casing **23** of the thermopile **21** is

kept at a constant known temperature by means of the device **22**, and consequently makes a constant contribution to the voltage V_B .

The intensity of the radiation is also correlated with the temperature T_P of the body by which it is emitted, in other words the blood of the patient P. More specifically, the total power of the emitted infrared radiation is a function of the temperature of the radiating body, according to the Stefan-Boltzmann law. The intensity of the emitted radiation increases with an increase in the temperature of the radiating body. In the case in question, the filter **38** selects only the electromagnetic radiation lying within the pass band B_P , and the voltage V_B generated by the thermopile **21** depends on the energy absorbed in this pass band B_P .

The temperature T_P can therefore be determined on the basis of the value of the voltage V_B , according to a known relation of the following type:

$$T_P = F(V_B) + T_0 \quad (1)$$

where $F(V_B)$ is an experimentally determined function and T_0 is the operating temperature at which the casing **23**, the support **21d** and the cold junctions **21b** of the thermopile **21** are all maintained.

In ordinary operating conditions, the variations of the temperature T_P are not more than a few degrees Celsius, and therefore the relation (1) can be approximated by the relation:

$$T_P = T_0 + K * V_B \quad (2)$$

where K is a known constant, since it is experimentally determined.

With reference to FIG. 7, the number **45** indicates a haemofiltration machine comprising the extracorporeal circuit **2** and a haemofiltration filter **46** comprising a blood-compartment **47** and a compartment **48** separated by a semi-permeable membrane **49**. The machine **45** is equipped with the blood monitoring equipment **10** and, in particular, is provided with the non-invasive device **16**.

The machine **45**, can carry out pure haemofiltration treatments and haemofiltration treatments in pre- and/or post-dilution.

The equipment **10** applied to the machine **45** is completely identical- to that associated with the machine **1**, and its operation is also identical.

The equipment **10** is particularly advantageous in that it can be connected to any type of blood purification machine, and does not require adaptation to the type of purification treatment in use.

Finally, modifications and variations can clearly be applied to the device described without departure from the scope of the present invention. In the first place, the use of the invention is not limited to dialysis machines alone, but can be extended to all cases in which a circuit for extracorporeal blood circulation is used. It is also possible to use infrared radiation measuring devices other than those described, such as devices made from semiconductor material with PN junctions. The non-invasive device could also be provided with a dedicated control unit, separate from that which is used to control the other parts of the equipment for regulating the blood temperature. The heat pump used can also be different from a Peltier cell. As an alternative to the use of a heat pump, it is possible to directly compensate the signal from the thermopile **21** by using the temperature of the casing **23**, which can be measured by means of the thermistor **28**.

The invention claimed is:

1. A control apparatus for an extracorporeal blood circuit, said extracorporeal blood circuit being connected to a blood purification machine, said extracorporeal blood circuit further comprising an arterial branch connected to at least one

blood treatment element and a venous branch connected to at least one blood treatment element,

the control apparatus comprising:

a non-invasive device for measuring a blood temperature, said non-invasive measuring device comprising:

a line fitted in the arterial branch upstream of said blood treatment element for receiving blood from a patient,

a temperature sensor connected to said line and generating a first signal indicative of a first blood temperature of the blood flowing in said line, said temperature sensor having an electromagnetic radiation intensity measuring device, and said line having a connecting portion of discoid shape facing said electromagnetic radiation intensity measuring device, said connecting portion being permeable to electromagnetic radiation in a first wave band, said first signal corresponding to an intensity of said electromagnetic radiation in said first wave band,

a temperature regulating device for regulating the blood temperature in the extracorporeal blood circuit, said device being connected to a portion of the venous branch downstream from said blood treatment element, and

a control unit connected to the temperature regulating device and configured to regulate a blood temperature in the extracorporeal blood circuit as a function of the first blood temperature and a reference temperature.

2. An apparatus according to claim 1, wherein said regulating device, is combined with said portion of the venous branch to form a heat exchange.

3. An apparatus according to claim 1, wherein said temperature regulating device comprises a line for conveying a fluid which can be heated to a fluid temperature lying within a specified range, about 37° C.

4. An apparatus according to claim 1, wherein said temperature regulating device has a seat configured to house said portion of the venous branch.

5. An apparatus according to claim 1, wherein said extracorporeal blood circuit is connected to a pump to convey the blood along the extracorporeal blood circuit, the apparatus comprising a sensor for detecting an operating state of the pump; the control unit keeping the fluid temperature substantially equal to said predetermined temperature when the pump is not in operation.

6. An apparatus according to claim 1, wherein said venous branch has a post-dilution node; said portion of the venous branch being located downstream of said post-dilution node.

7. An apparatus according to claim 1, wherein said blood treatment element comprises a hemodialysis filter, said hemodialysis filter comprising a blood compartment and a dialysate compartment within which a dialysate flows.

8. An apparatus according to claim 1, wherein said blood treatment element comprises a hemodialysis filter comprising a blood compartment and a dialysate compartment within which a dialysate flows, and a pre- or post-dilution node for the introduction of a replacement fluid.

9. An apparatus according to claim 1, wherein said blood treatment element comprises a hemofiltration filter.

10. An apparatus according to claim 1, wherein said blood treatment element comprises a hemofiltration filter and a pre- or post-dilution node for the introduction of a replacement fluid.

11. An apparatus according to claim 1, wherein said control unit regulates the blood temperature in the extracorporeal blood circuit as a function of the first blood temperature and the reference temperature at predetermined time intervals.

12. An apparatus according to claim 1, or 11, wherein said control unit regulates the overall temperature as a function of the difference between the first blood temperature and the reference temperature.

13. An apparatus according to claim 1, wherein said measuring device is housed within a casing, the measuring device being configured behind a window formed in said casing; said connecting portion of discoid shape being completely superimposed on said window, to cover a solid angle of view of said measuring device.

14. An apparatus according to claim 1, wherein said measuring device comprises a thermopile having at least one hot junction and at least one cold junction.

15. An apparatus according to claim 14, wherein said temperature sensor comprises a temperature controller, said temperature controller maintaining the at least one cold junction at a controlled temperature.

16. An apparatus according to claim 15, wherein said temperature controller comprises:

a thermistor connected thermally to the cold junction of said measuring device, said thermistor supplying a second signal, said second signal corresponding to said controlled temperature;

a solid state heat pump, having a low temperature surface thermally connected to said measuring device and a high temperature surface; and

a control circuit connected to said thermistor, the control circuit configured to receive said second signal, said control circuit also being connected to said heat pump to supply a control signal correlated with said second signal.

17. An apparatus according to claim 16, wherein said heat pump comprises a Peltier cell.

18. An apparatus according to claim 17, comprising a heat sink element placed in contact with said high temperature surface of said heat pump.

19. An apparatus according to claim 18, wherein said controlled temperature is a constant temperature in the range from 5° C. to 15° C.

20. An apparatus according to claim 1, wherein said connecting portion is made from a material which, in said first wave band, has a substantially constant transmittance and an absorbance substantially equal to zero.

21. An apparatus according to claim 1, wherein said connecting portion is made from a material having an essentially constant transmittance in a temperature range from 30° C. to 40° C.

22. An apparatus according to claim 1, wherein said connecting portion is made from a material chosen from a group including high-density polyethylene, low-density polyethylene, and poly(4-methyl-1-pentene).

23. An apparatus according to claim 1, further comprising a filter interposed between said measuring device and said connecting portion of said line.

24. An apparatus according to claim 23, wherein said filter comprises a sheet of material being substantially opaque to electromagnetic radiation outside a second wave band and lying within said first wave band.

25. An apparatus according to claim 24, wherein said second wave band is in a range from 8 μm to 14 μm.

26. An apparatus according to claim 24, wherein said filter includes germanium.

27. An apparatus according to claim 24, wherein said filter has one face facing said connecting portion of said line.

28. An apparatus according to claim 24, wherein an infrared radiation band includes at least a portion of said first wave band.

UNITED STATES PATENT AND TRADEMARK OFFICE
CERTIFICATE OF CORRECTION

PATENT NO. : 7,648,475 B2
APPLICATION NO. : 10/500336
DATED : January 19, 2010
INVENTOR(S) : De Cicco et al.

Page 1 of 1

It is certified that error appears in the above-identified patent and that said Letters Patent is hereby corrected as shown below:

Column 7, line 64, "claim 1, or 11," should read --claim 1 or 11,--.

Signed and Sealed this

Twentieth Day of April, 2010

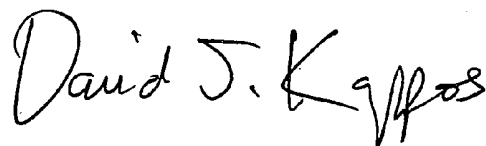
A handwritten signature in black ink that reads "David J. Kappos". The signature is written in a cursive style with a large, stylized 'D' and 'K'.

David J. Kappos
Director of the United States Patent and Trademark Office

专利名称(译)	用于测量用于血液体外循环的回路中的血液温度的非侵入性装置，以及具有该装置的设备		
公开(公告)号	US7648475	公开(公告)日	2010-01-19
申请号	US10/500336	申请日	2002-12-20
[标]申请(专利权)人(译)	德希科吉奥吉奥 Fontanazzi介绍FRANCESCO DELNEVO安娜丽莎 ZACCARELLI MASSIMO FRANCESCO鲍里尼		
申请(专利权)人(译)	德希科吉奥吉奥 Fontanazzi介绍FRANCESCO DELNEVO安娜丽莎 ZACCARELLI MASSIMO FRANCESCO鲍里尼		
当前申请(专利权)人(译)	GAMBRO Lundia酒店AB		
[标]发明人	DE CICCO GIORGIO FONTANAZZI FRANCESCO DELNEVO ANNALISA ZACCARELLI MASSIMO PAOLINI FRANCESCO		
发明人	DE CICCO, GIORGIO FONTANAZZI, FRANCESCO DELNEVO, ANNALISA ZACCARELLI, MASSIMO PAOLINI, FRANCESCO		
IPC分类号	A61M37/00 A61M1/00 A61M31/00 C02F1/00 G01K13/02 A61B5/00 A61M1/14 A61M1/36 G01J5/04 G01K1/14 G01K11/00 G01K13/00		
CPC分类号	A61M1/367 G01J5/0037 G01J5/04 G01J5/061 G01J5/12 G01K1/143 G01K11/006 A61M2205/3368		
优先权	102001900981405 2001-12-28 IT		
其他公开文献	US20050094704A1		
外部链接	Espacenet USPTO		

摘要(译)

用于测量用于血液体外循环的回路中的血液温度的非侵入性装置包括从患者采集的血液流动的线。该装置还包括连接到线路的温度传感器，并设有用于测量电磁辐射强度的装置。测量装置面向线路的连接部分或窗口，该连接部分或窗口可通过第一波段中的电磁辐射透射，并产生第一信号，该第一信号与第一波段中的电磁辐射相关，因此与在第一波段中流动的血液的温度相关。线。

