



US006514214B2

(12) **United States Patent**
Kokate et al.

(10) **Patent No.:** **US 6,514,214 B2**
(45) **Date of Patent:** **Feb. 4, 2003**

(54) **INTRAVASCULAR TEMPERATURE SENSOR**

WO WO 00/27278 5/2000
WO WO 00/54673 9/2000

(75) Inventors: **Jaydeep Y. Kokate**, Maple Grove, MN (US); **Eric M. DoBrava**, Crystal, MN (US); **Marwane S. Berrada**, Minneapolis, MN (US); **Scott Kimmel**, Saint Paul, MN (US); **Suzana Prstic**, Minneapolis, MN (US); **Michael F. Hoey**, Shoreview, MN (US); **Avram Bar-Cohen**, Saint Louis Park, MN (US); **Paul A. Iaizzo**, White Bear Lake, MN (US)

OTHER PUBLICATIONS

Buja et al., "Role of Inflammation in Coronary Plaque Disruption," *Circulation*, vol. 89, No. 1, Jan. 1994, pp. 503-505.

Casscells et al., "Thermal Detection of Cellular Infiltrates in Living Atherosclerotic Plaques: Possible Implications for Plaque Rupture and Thrombosis," *The Lancet*, vol. 347, May 25, 1995, pp. 1447-1449.

Davies, M.J., "Detecting Vulnerable Coronary Plaques," *The Lancet*, vol. 347, May 25, 1996, pp. 1422-1423.

Falk et al., "Coronary Plaque Disruption," *Circulation*, vol. 92, No. 3, Aug. 1, 1995, pp. 657-671.

Muller et al., "Triggers, Acute Risk Factors and Vulnerable Plaques: The Lexicon of a New Frontier," *JACC*, vol. 23, No. 3, Mar. 1, 1994, pp 809-813.

van der Wal et al., Site of Intimal Rupture or Erosion of Thrombosed Coronary Atherosclerotic Plaques is Characterized by an Inflammatory Process Irrespective of the Dominate Plaque Morphology, *Circulation*, vol. 89, No. 1, Jan. 1994, pp. 36-44.

(73) Assignee: **SciMed Life Systems, Inc.**, Maple Grove, MN (US)

(*) Notice: Subject to any disclaimer, the term of this patent is extended or adjusted under 35 U.S.C. 154(b) by 11 days.

(21) Appl. No.: **09/782,502**

(22) Filed: **Feb. 13, 2001**

(65) **Prior Publication Data**

US 2002/0111560 A1 Aug. 15, 2002

(51) **Int. Cl.**⁷ **A61B 5/00**

(52) **U.S. Cl.** **600/549**; 600/505

(58) **Field of Search** 600/407, 585, 600/433-435, 473, 474, 479, 549, 504, 505; 604/96.01, 915; 374/100, 112

(56) **References Cited**

U.S. PATENT DOCUMENTS

3,273,395 A	9/1966	Schwarz	374/133
3,866,599 A	2/1975	Johnson	600/342
3,913,568 A	10/1975	Carpenter	600/142

(List continued on next page.)

FOREIGN PATENT DOCUMENTS

EP	0 856 278 A2	8/1998
WO	WO 97/10748	3/1997

Primary Examiner—Kevin Shaver

Assistant Examiner—Charles Marmor, II

(74) *Attorney, Agent, or Firm*—Fish & Richardson P.C., P.A.

(57) **ABSTRACT**

Devices and methods for detecting vulnerable plaque within a blood vessel are disclosed. A catheter in accordance with the present invention includes an elongate shaft having a proximal end, a distal end, and an outer surface. At least one temperature sensor is disposed proximate to the distal end of the elongate shaft. In one preferred embodiment, the at least one temperature sensor is adapted to contact an inner surface of the blood vessel. In another preferred embodiment, at least one temperature sensor is disposed within a channel defined by a body member that is disposed about the elongate shaft.

33 Claims, 6 Drawing Sheets

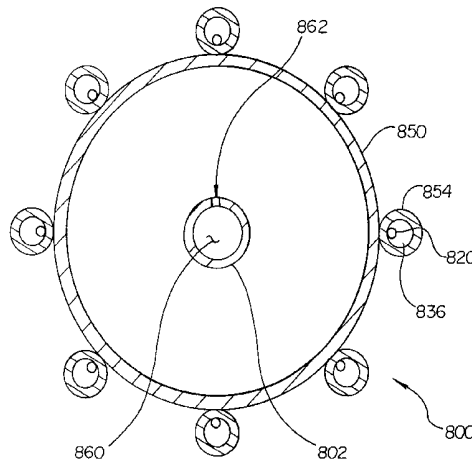
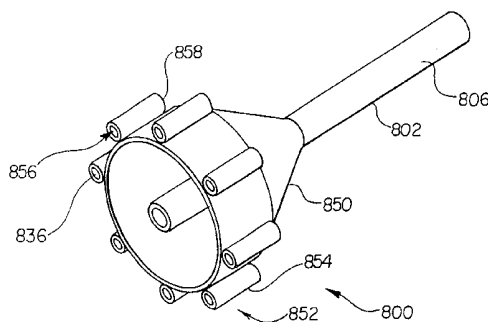

U.S. PATENT DOCUMENTS

4,005,605 A	2/1977	Michael	374/129	5,279,565 A	1/1994	Klein et al.	604/105
RE32,204 E	7/1986	Halvorsen	600/374	5,304,173 A	4/1994	Kittrell et al.	606/15
4,602,642 A	7/1986	O'Hara et al.	600/474	5,313,949 A	5/1994	Yock	600/467
4,699,147 A	10/1987	Chilson et al.	600/374	5,336,178 A	8/1994	Kaplan et al.	604/509
4,752,141 A	6/1988	Sun et al.	374/161	5,373,849 A	12/1994	Maroney et al.	600/463
4,776,334 A	10/1988	Prionas	606/42	5,445,157 A	8/1995	Adachi et al.	600/474
4,777,955 A	10/1988	Brayton et al.	600/374	5,542,915 A	8/1996	Edwards et al.	604/22
4,784,149 A	11/1988	Berman et al.	600/474	5,547,472 A	8/1996	Onishi et al.	604/163.01
4,790,324 A	12/1988	O'Hara et al.	600/474	5,558,093 A	9/1996	Pomeranz	600/437
4,794,931 A	1/1989	Yock	600/439	5,606,974 A	3/1997	Castellano et al.	600/462
4,797,840 A	1/1989	Fraden	702/104	5,623,940 A	4/1997	Daikuzono	600/439
4,841,981 A	6/1989	Tanabe et al.	600/505	5,682,899 A	11/1997	Nashef et al.	600/505
4,862,887 A	9/1989	Weber et al.	606/15	5,733,739 A	3/1998	Zakim et al.	435/29
4,986,671 A	1/1991	Sun et al.	374/131	5,792,070 A *	8/1998	Kauphusman et al.	600/549
4,995,398 A	2/1991	Turnidge	600/508	5,849,028 A	12/1998	Chen	607/102
5,000,185 A	3/1991	Yock	600/459	5,871,449 A	2/1999	Brown	600/474
5,046,501 A	9/1991	Crilly	600/477	5,906,363 A	5/1999	Reis et al.	269/21
5,057,105 A	10/1991	Malone et al.	606/28	5,924,997 A	7/1999	Campbell	600/549
5,057,106 A	10/1991	Kasevich et al.	606/33	5,935,075 A	8/1999	Casscells et al.	600/474
5,109,859 A	5/1992	Jenkins	600/439	5,957,961 A	9/1999	Maguire et al.	607/99
5,174,299 A	12/1992	Nelson	600/505	6,162,184 A	12/2000	Swanson et al.	600/549
5,217,456 A	6/1993	Narciso, Jr.	606/15	6,197,021 B1	3/2001	Panescu et al.	606/31
5,237,996 A	8/1993	Waldman et al.	600/374	6,245,026 B1 *	6/2001	Campbell et al.	600/549
5,275,594 A	1/1994	Baker et al.	606/12	2001/0053882 A1 *	12/2001	Haddock et al.	600/549

* cited by examiner

Fig. 1

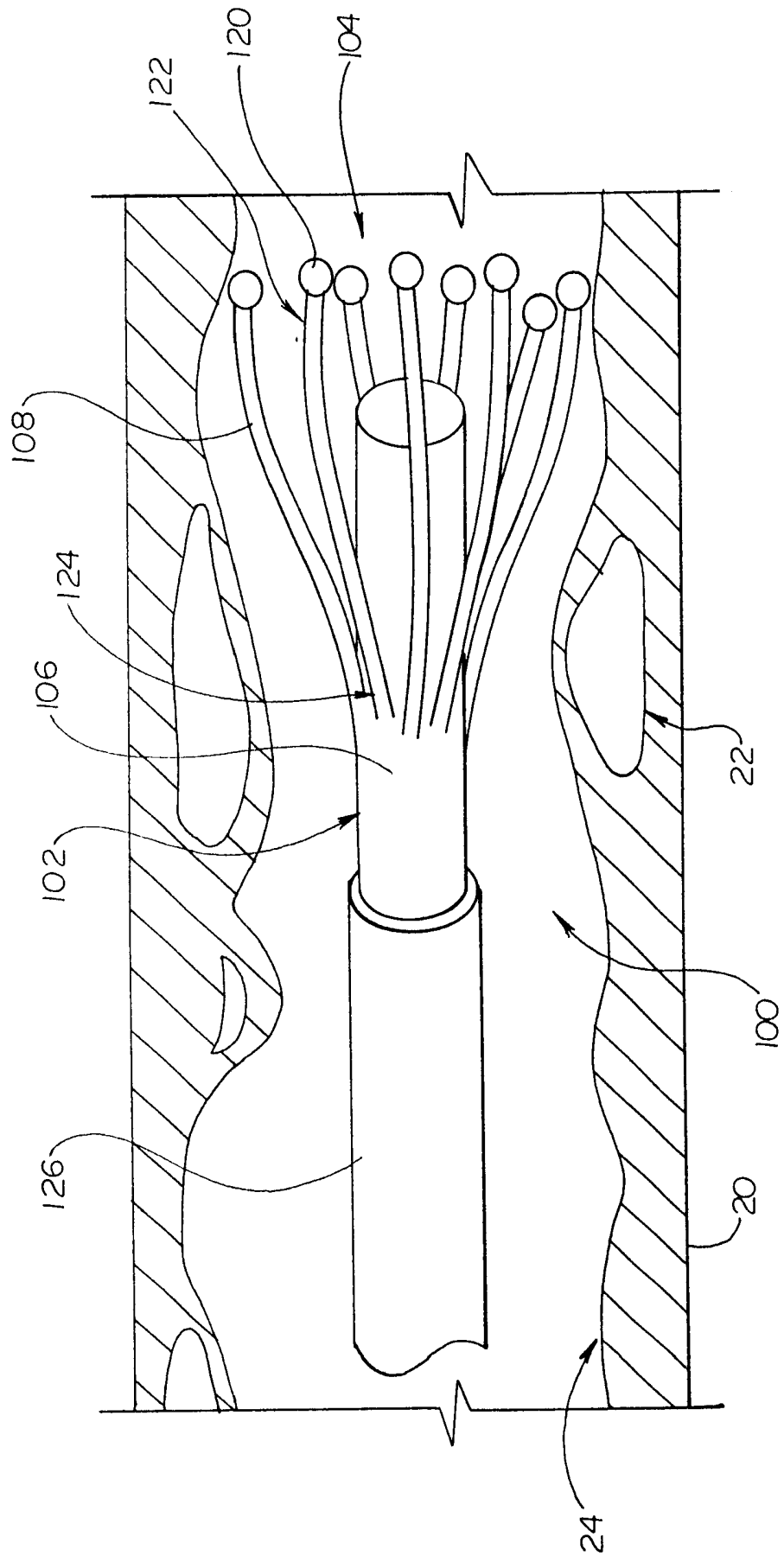

Fig. 2

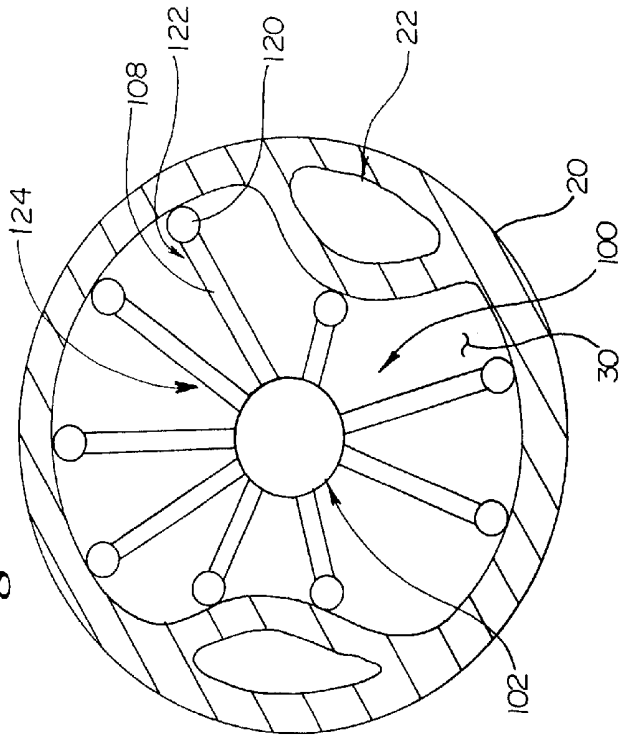

Fig. 3

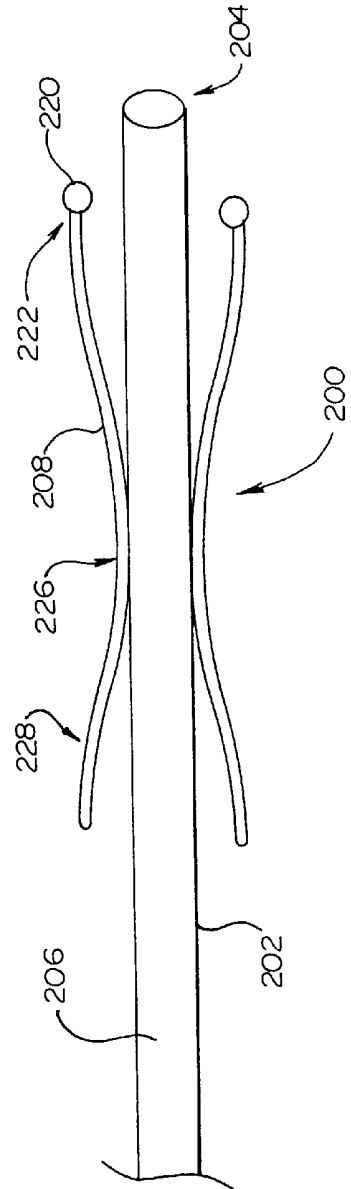

Fig. 4

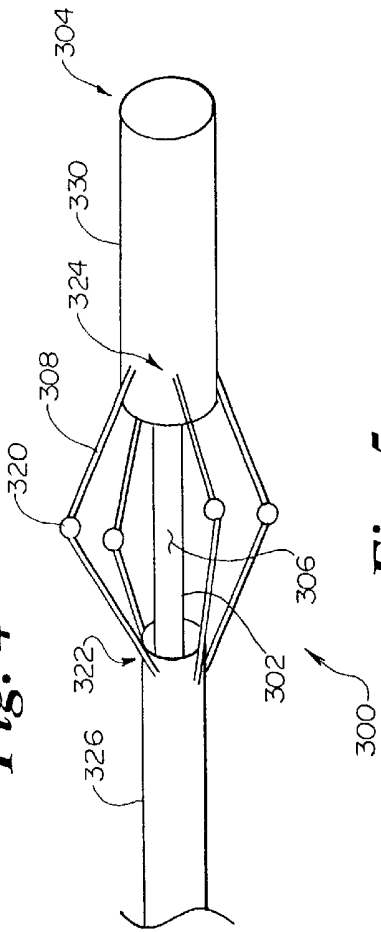

Fig. 5

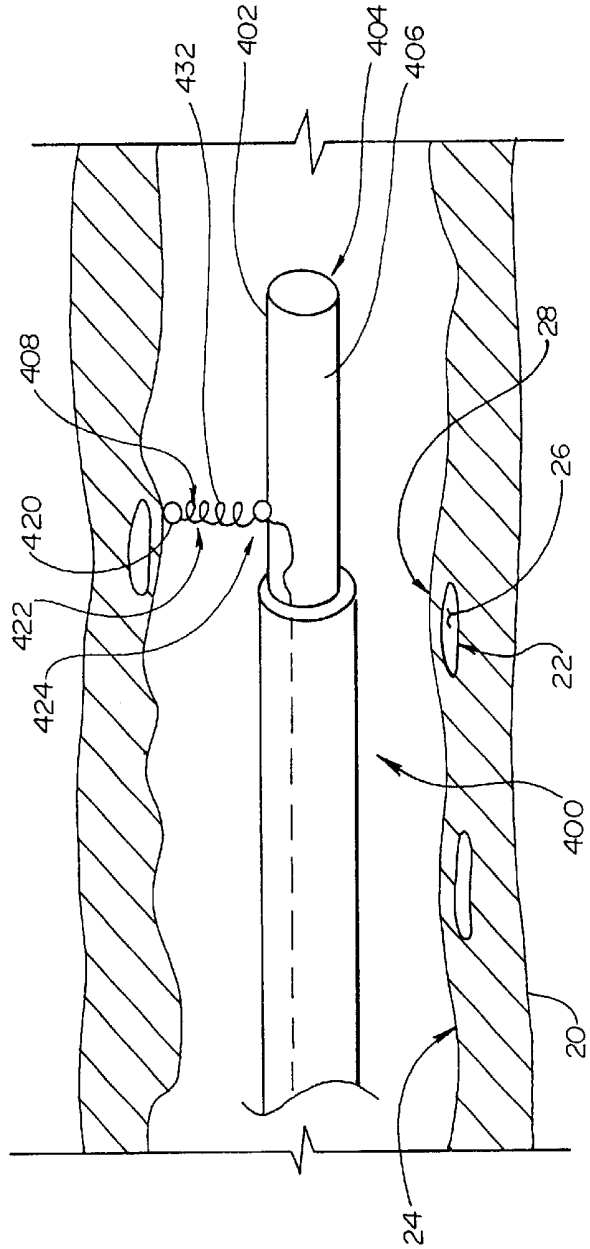

Fig. 6

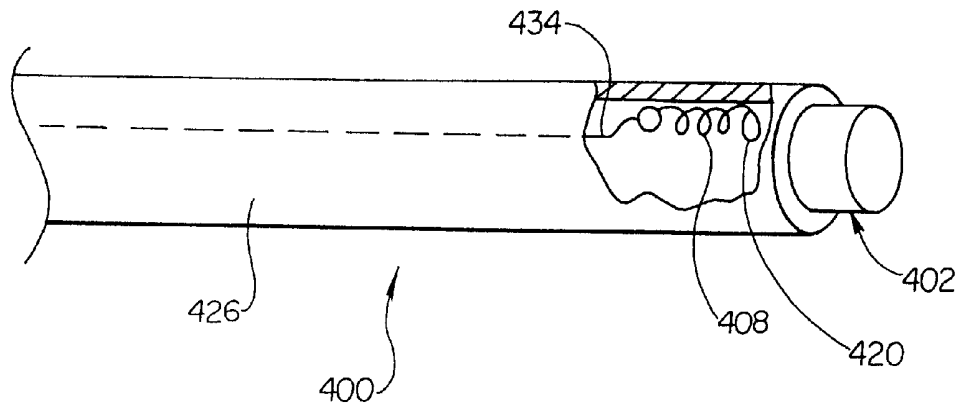

Fig. 7

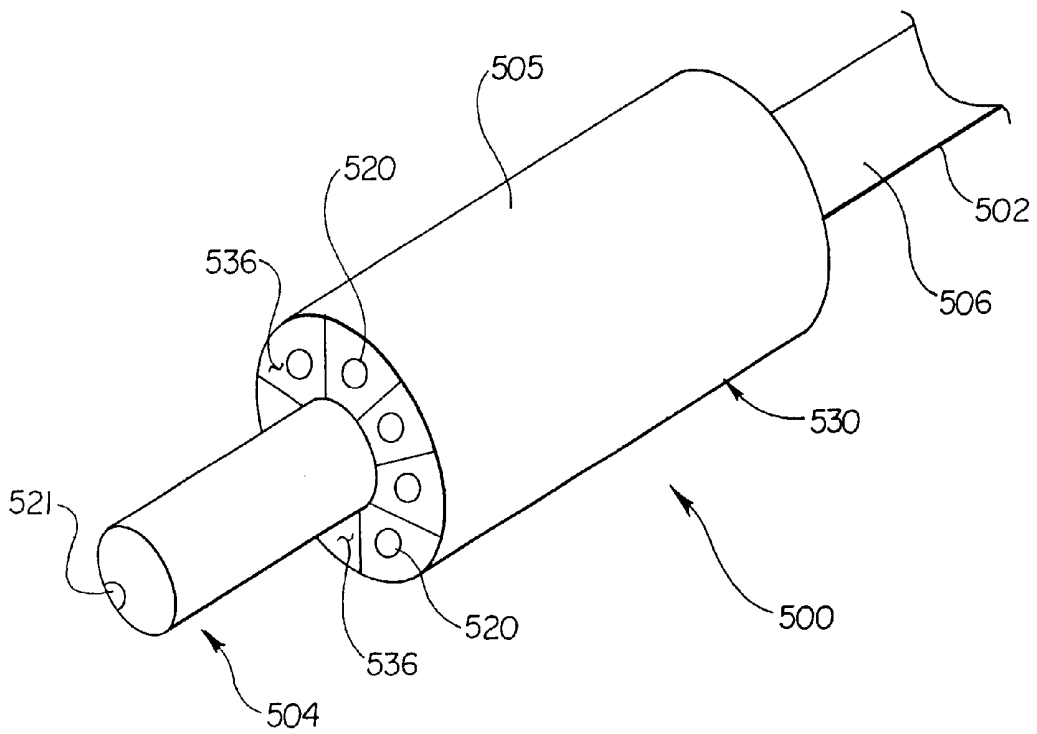

Fig. 8

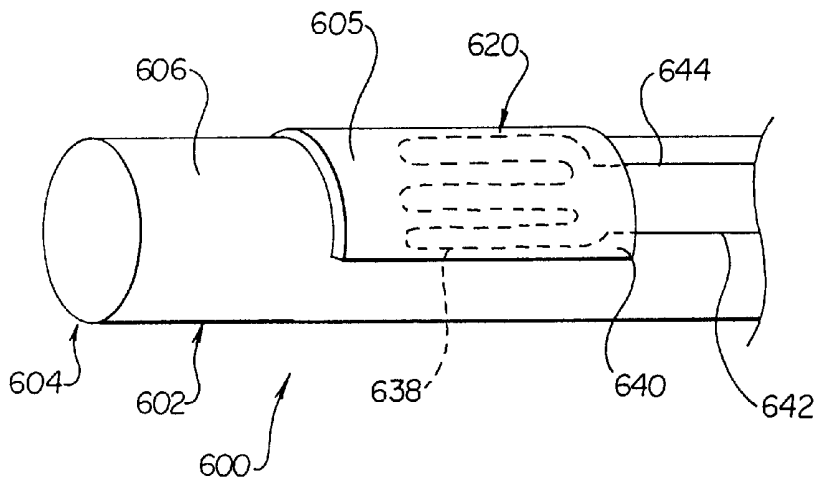

Fig. 9

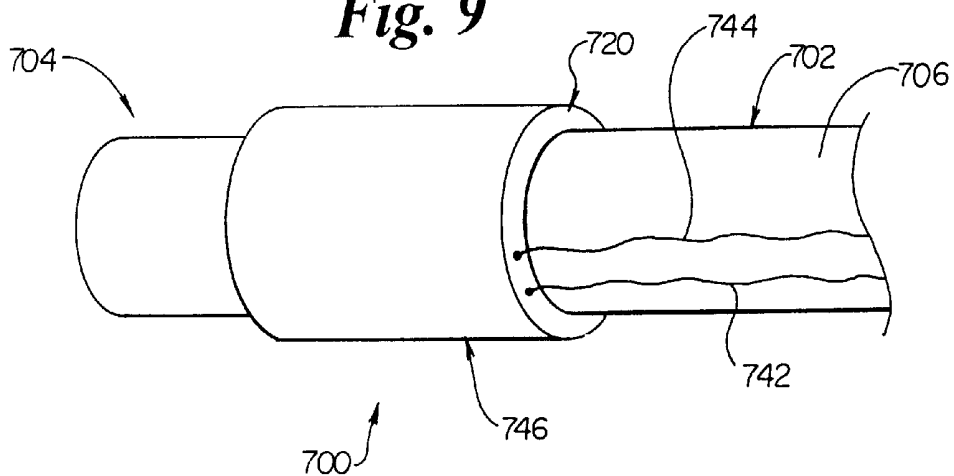

Fig. 10

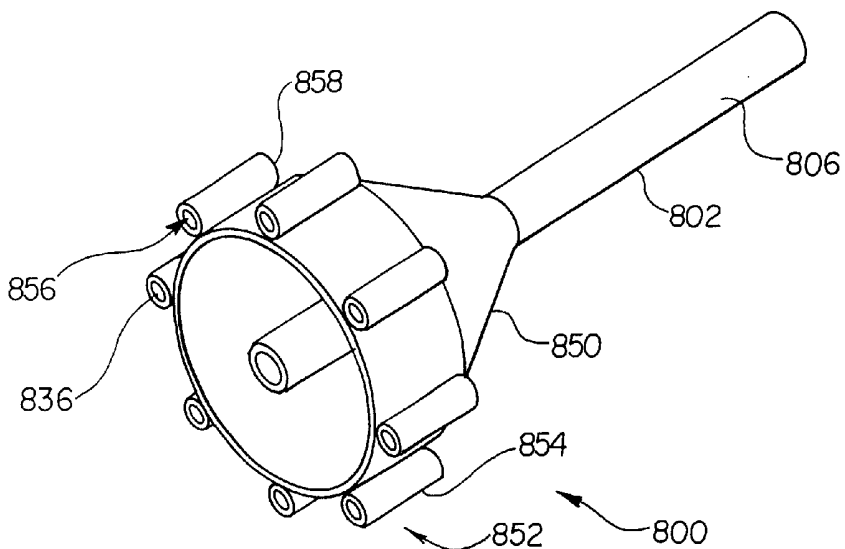

Fig. 11

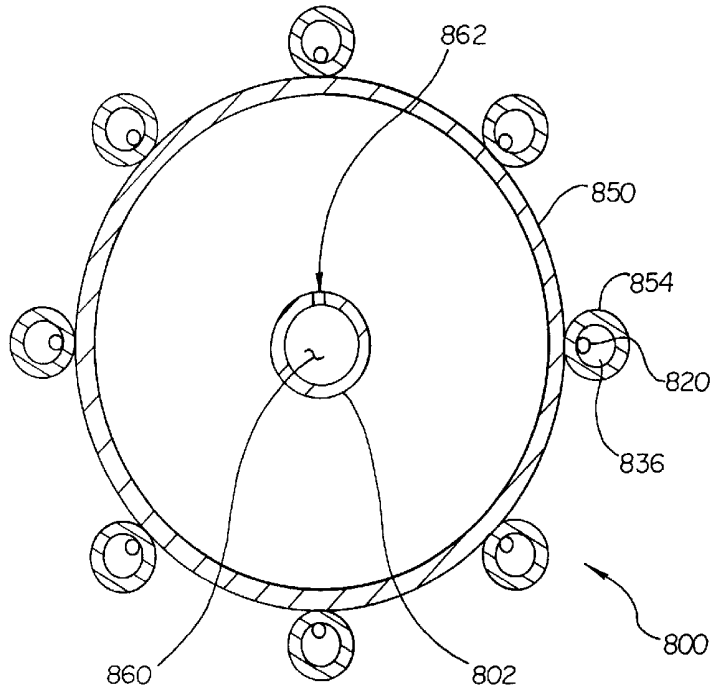
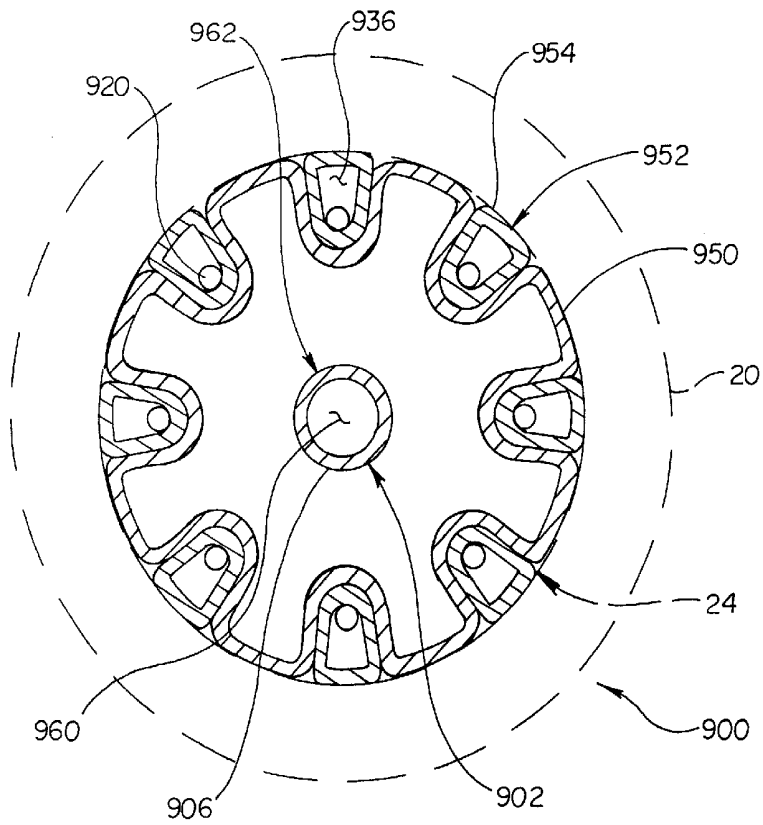

Fig. 12



INTRAVASCULAR TEMPERATURE SENSOR**FIELD OF THE INVENTION**

The present invention relates generally to medical devices for detecting cardiac disease. More particularly, the present invention relates to medical devices for detecting vulnerable plaque within a blood vessel.

BACKGROUND OF THE INVENTION

Therapy modalities for heart disease have traditionally focused on treating blood vessels which have become occluded (blocked) or stenotic (narrowed) by calcified plaque deposits. Blood vessels which have become occluded or stenotic in this manner may interrupt the blood flow which supplies oxygen to the heart muscle. Occluded or stenotic blood vessels may be treated with a number of medical procedures including angioplasty and atherectomy. Angioplasty techniques such as percutaneous transluminal angioplasty (PTA) and percutaneous transluminal coronary angioplasty (PTCA) are relatively noninvasive methods of treating restrictions in blood vessels. In these procedures, a balloon catheter is advanced over a guidewire until the balloon is positioned proximate to a restriction in a diseased vessel. The balloon is then inflated and the restriction in the vessel is stretched. During an atherectomy procedure, the stenotic lesion is mechanically cut or abraded away from the blood vessel wall using an atherectomy catheter.

Calcified plaque deposits typically comprise hard materials. But, plaque may also comprise soft materials or combinations of soft and hard materials. Soft plaque typically comprises deposits of cholesterol and other fats which build up within the blood vessels as a patient ages. The build up of plaque in the blood vessels is sometimes referred to as atherosclerosis, or hardening of the arteries.

Atherosclerosis often begins as a small injury to an artery wall. This injury triggers a cascade of injury and response, inflammation, and healing, which may ultimately lead to the narrowing of the artery. As the atherosclerotic plaque worsens, inflammatory cells, especially macrophages, collect, at the site to isolate, the debris of the damaged tissue. The result is a core of lipid, macrophages or foam cells and necrotic tissue, covered by a thin fibrous cap of scar tissue. If the fibrous cap becomes weakened or is subjected to excessive mechanical stress, it may rupture, exposing the thrombogenic damaged endothelium and metabolic byproducts to the blood stream. If the resulting blood clot is severe enough, it may occlude the artery. If this obstruction persists in a coronary artery, a myocardial infarction or angina may result.

Plaque deposits which are at risk of rupturing are sometimes referred to as vulnerable plaque. Vulnerable plaque typically comprises a core of soft materials covered with a fibrous cap. Many vulnerable plaque deposits do not limit the flow of blood through the blood vessels. It has recently been appreciated that vulnerable plaques which do not limit flow may be particularly dangerous because they can rupture suddenly causing heart attack and death. This may occur, for example, when the vulnerable plaque ruptures and a blood clot is formed inside the blood vessel lumen causing a blockage.

Recently, the pivotal role of inflammation in the progression of atherosclerosis has been recognized. A systemic increase in temperature is often associated with infection (e.g., a fever). Likewise, a local infection or localized damage to tissue may result in a localized increase in

temperature. An increase in temperature is thought to be caused by the response of the immune system to infection, known as inflammation and an increase in metabolic activity involved in the healing process. It has been observed that the inflamed necrotic core of a vulnerable plaque maintains itself at a temperature which may be one or more degrees Celsius higher than the surrounding tissue. For example, an inflamed plaque in a human heart, where the normal temperature is about 37° C. may be at a temperature as high as 40° C.

SUMMARY OF THE INVENTION

The present invention relates generally to medical devices for detecting cardiac disease. More particularly, the present invention relates to medical devices for detecting vulnerable plaque within a blood vessel. A catheter in accordance with one embodiment of the present invention includes an elongate shaft and a plurality of arms fixed to the elongate shaft.

The arms preferably have an extended position and a retracted position. A sensor is fixed to each arm proximate a first end thereof. In a preferred embodiment, each sensor contacts the inner surface of a blood vessel when the arms are in the extended position. In a preferred embodiment, a sheath is disposed about the elongate shaft. The arms may be urged into the retracted position by advancing the sheath distally along the elongate shaft.

The signal from each sensor may be displayed and/or recorded using a suitable instrument. Variations in these signals may be noted as the catheter is moved proximally and/or distally through the blood vessel thermally mapping the transversed region. The variations in the sensor signal may be correlated with the axial position of the catheter. This information may be used to identify the position of any vulnerable plaque deposits in the blood vessel.

In a preferred embodiment, the arms of the catheter expand radially away from the elongate shaft. The angular orientation of plaque deposits within the blood vessel may be identified by observing variations between the signals from the different sensors. For example, sensors which are proximate to vulnerable plaque deposits may read higher temperatures than sensors which are not proximate to vulnerable plaque deposits.

A catheter in accordance with an additional embodiment of the present invention includes one arm comprising a spring which is biased to assume an extended position. A sensor is fixed to the arm proximate a first end thereof. This catheter may also be used for mapping the locations of vulnerable plaque deposits within a blood vessel.

In a preferred embodiment, the sensor contacts the inner surface of the blood vessel when the arm is in the extended position. In this preferred embodiment, the temperature measured by the sensor may rise when the sensor is proximate to a vulnerable plaque deposit. Variations in the temperature measured by the sensor may be noted as the catheter is moved proximally and/or distally through the blood vessel, and these variations may be correlated to the axial position of vulnerable plaque deposits.

Variations in the signal from the sensor may also be noted as the catheter is rotated about its longitudinal axis. These variations may be correlated to the angular location of vulnerable plaque deposits within the blood vessel.

Yet another exemplary embodiment of a catheter in accordance with the present invention includes a body member disposed about an elongate shaft of the catheter. The body member defines a plurality of flow channels and a temperature sensor is disposed within each channel. This catheter

may also be used along with methods in accordance with the present invention for mapping the locations of vulnerable plaque deposits within the blood vessel.

The body member of the catheter is preferably sized so that an outer surface of the body member is disposed proximate the inner surface of the blood vessel. When this is the case, blood flowing proximate the inner surface of the blood vessel will flow into the channels. Sensors may be used to measure the temperature of the blood flowing through the channels. Blood which flows over a vulnerable plaque deposit will be warmed by the vulnerable plaque deposit. The increased temperature of this blood may be observed and/or recorded using the sensors disposed within the channels.

As the catheter is moved proximally and/or distally through the blood vessel, the distal end of the body member will be proximate different portions of the inner surface of the blood vessel. Variations in the signals from the sensors may be noted as the catheter is moved proximally and/or distally through the blood vessel, and these variations may be correlated to the axial position of the catheter. This information may be used to identify an axial component of the position of any vulnerable plaque deposits in the blood vessel.

The flow channels and the sensors are preferably disposed radially about the elongate shaft. An angular component of the position of plaque deposits within the blood vessel may be identified by observing variations between the signals from the different sensors. For example, sensors which are proximate vulnerable plaque deposits may read higher temperatures than sensors which are not proximate vulnerable plaque deposits.

BRIEF DESCRIPTION OF THE DRAWINGS

FIG. 1 is a perspective view of a catheter in accordance with an exemplary embodiment of the present invention;

FIG. 2 is a lateral cross-sectional view of a blood vessel, and the catheter of FIG. 1 is shown disposed within a lumen defined by the blood vessel;

FIG. 3 is a plan view of a catheter in accordance with an additional exemplary embodiment of the present invention;

FIG. 4 is a perspective view of a catheter in accordance with yet another exemplary embodiment of the present invention;

FIG. 5 is a perspective view of a catheter in accordance with an exemplary embodiment of the present invention;

FIG. 6 is a partial cross sectional view of the catheter of FIG. 5.

FIG. 7 is a perspective view of a catheter in accordance with still another exemplary embodiment of the present invention;

FIG. 8 is a perspective view of a catheter in accordance with still another exemplary embodiment of the present invention;

FIG. 9 is a perspective view of a catheter in accordance with still another exemplary embodiment of the present invention;

FIG. 10 is a cross sectional perspective view of a catheter in accordance with still another exemplary embodiment of the present invention;

FIG. 11 is a cross sectional plan view of the catheter of FIG. 10; and

FIG. 12 is a cross sectional plan view of a catheter in accordance with yet another exemplary embodiment of the present invention.

DETAILED DESCRIPTION OF THE INVENTION

The following detailed description should be read with reference to the drawings, in which like elements in different drawings are numbered in like fashion. The drawings which are not necessarily to scale, depict selected embodiments and are not intended to limit the scope of the invention. In some cases, the drawings may be highly diagrammatic in nature. Examples of constructions, materials, dimensions, and manufacturing processes are provided for various elements. Those skilled in the art will recognize that many of the examples provided have suitable alternatives which may be utilized.

FIG. 1 is a perspective view of a catheter 100 in accordance with an exemplary embodiment of the present invention. Catheter 100 may be used for mapping the locations of vulnerable plaque deposits 22 within a blood vessel 20. Catheter 100 comprises an elongate shaft 102 having a distal end 104, a proximal end (not shown in FIG. 1) and an outer surface 106. Catheter 100 also includes a plurality of arms 108. In the embodiment of FIG. 1, a sensor 120 is fixed to each arm 108 proximate a first end 122 thereof. A second end 124 of each arm 108 is fixed to elongate shaft 102.

Arms 108 preferably have an extended position and a retracted position. In the embodiment of FIG. 1, arms 108 are shown in the extended position. A sheath 126 is disposed about elongate shaft 102. Arms 108 may be urged into the retracted position by advancing sheath 126 distally along elongate shaft 102. In a preferred embodiment, each sensor 120 contacts inner surface 24 of blood vessel 20 when arms 108 are in the extended position.

Each sensor 120 may comprise a temperature sensor, an ultrasonic sensor, and/or an electromagnetic radiation sensor. In a preferred embodiment, each sensor 120 comprises a temperature sensor. Examples of temperature sensors which may be suitable in some applications include resistance temperature devices (RTS's), thermistors, thermocouples, MEMS (microelectrical mechanical systems), and microbolometers.

Blood vessel 20 includes a plurality of vulnerable plaque deposits 22. Each vulnerable plaque deposit includes a core portion 26 comprising a relatively soft material and a cap 28 overlaying the core. As catheter 100 is moved proximally and/or distally through blood vessel 20, sensors 120 preferably contact different portions of inner surface 24 of blood vessel 20.

The signal from each sensor 120 may be displayed and/or recorded using a suitable instrument. Variations in these signals may be noted as catheter 100 is moved proximally and/or distally through blood vessel 20. The variations in the sensor signal may be correlated with the axial position of catheter 100. This information may be used to identify the position of any vulnerable plaque deposits in blood vessel 20.

FIG. 2 is a lateral cross-sectional view of a blood vessel 20. Catheter 100 of FIG. 1 is shown disposed within a lumen 30 of blood vessel 20. Catheter 100 may be used for mapping the location of vulnerable plaque deposits 22 within a blood vessel 20 as described above. In FIG. 2, it may be appreciated that arms 108 of catheter 100 expand radially away from elongate shaft 102. A sensor 120 is fixed to each arm 108 proximate a first end 122 thereof. A second end 124 of each arm 108 is fixed to elongate shaft 102. The angular orientation of plaque deposits 22 within blood vessel 20 may be identified by observing variations between the signals from the different sensors 120. For example, sensors

120 which are proximate vulnerable plaque deposits 22 may read higher temperatures than sensors 120 which are not proximate vulnerable plaque deposits.

FIG. 3 is a plan view of a catheter 200 in accordance with an additional exemplary embodiment of the present invention. Catheter 200 comprises an elongate shaft 202 having a distal end 204, a proximal end (not shown in FIG. 3) and an outer surface 206. Catheter 200 also includes a plurality of arms 208. In the embodiment of FIG. 3, a sensor 220 is fixed to each arm 208 proximate a first end 222 thereof. A middle portion 226 of each arm 208 is fixed to elongate shaft 202 of catheter 200, and a free portion 228 of each arm 208 extends away from elongate shaft 202. In a preferred embodiment, free portions 228 of arms 208 act to stabilize the flow of blood when catheter 200 is disposed within a blood vessel. In the embodiment of FIG. 3, arms 208 are shown in the extended position. Arms 208 preferably have an extended position and a retracted position.

FIG. 4 is a perspective view of a catheter 300 in accordance with yet another exemplary embodiment of the present invention. Catheter 300 may be used for mapping the locations of vulnerable plaque deposits within a blood vessel. Catheter 300 comprises an elongate shaft 302 having a distal end 304, a proximal end (not shown in FIG. 4) and an outer surface 306.

A sheath 326 is slidably disposed about a portion of elongate shaft 302. The first ends 322 of a plurality of arms 308 are fixed to sheath 326. The second end 324 of each arm 308 is fixed to a body member 330 of catheter 300. In the embodiment of FIG. 4, body member 330 is disposed about elongate shaft 302 proximate distal end 304. A sensor 320 is fixed to each arm 308 between first end 322 and second end 324. In the embodiment of FIG. 4, arms 308 are shown in the extended position. In a preferred embodiment, arms 308 are biased to assume the extended position. Arms 308 may be urged into a retracted position by moving sheath 326 proximally relative to elongate shaft 302. Arms 308 may also be urged into the extended position by moving sheath 326 distally relative to elongate shaft 302. In a preferred embodiment, each sensor 320 contacts the inner surface of a blood vessel when arms 308 are in the extended position.

Each sensor 320 may comprise various sensor types without deviating from the spirit and scope of the present invention. Examples of sensors which may be suitable in some applications include pressure sensors, ultrasonic sensors, electromagnetic radiation sensors, and temperature sensors. In a preferred embodiment, each sensor 320 comprises a temperature sensor. Temperature sensors which may be suitable in some applications, include resistance temperature devices (RTD's), thermistors, thermocouples, and MEMS.

FIG. 5 is a perspective view of a catheter 400 in accordance with an exemplary embodiment of the present invention. Catheter 400 also includes an arm 408 comprising spring 432 which is biased to assume the extended position shown in FIG. 5. A sensor 420 is fixed to arm 408 proximate a first end 422 thereof. A second end 424 of arm 408 is fixed to an elongate shaft 402. Elongate shaft 402 includes a distal end 404, a proximal end (not shown in FIG. 5) and an outer surface 406.

In FIG. 5, catheter 400 is shown disposed within a blood vessel 20 having vulnerable plaque deposits 22. Catheter 400 may be used for mapping the locations of the vulnerable plaque deposits 22 within blood vessel 20. In a preferred embodiment, sensor 420 contacts inner surface 24 of blood vessel 20 when arm 408 is in the extended position shown

in FIG. 5. In this preferred embodiment, the temperature measured by sensor 420 may rise when sensor 420 is proximate a vulnerable plaque deposit 22.

Each vulnerable plaque deposit shown in FIG. 5 includes a core portion 26 comprising a relatively soft material and a cap 28 overlaying the core. As catheter 400 is moved proximally and/or distally through blood vessel 20, sensors 420 preferably contact different portions of inner surface 24 of blood vessel 20.

The signal from sensor 420 may be displayed and/or recorded using a suitable instrument. Variations in the signal may be noted as catheter 400 is moved proximally and/or distally through blood vessel 20, and these variations may be correlated with the axial position of catheter 400. Variations in the signal from sensor 420 may also be noted as catheter 400 is rotated about its longitudinal axis. These variations may be correlated with the angular orientation of catheter 400. The information collected from sensor 420 may be used to identify the position of any vulnerable plaque deposits in blood vessel 20.

FIG. 6 is a partial cross sectional view of catheter 400 of FIG. 5. In FIG. 6, it may be appreciated that catheter 400 includes a sheath 426 which is disposed about elongate shaft 402. In the embodiment of FIG. 6, sheath 426 has been advanced distally along elongate shaft 402 so that arm 408 of catheter 400 is disposed in a retracted position. In FIG. 6 it may be appreciated that catheter 400 includes a cable 434 disposed between sheath 426 and elongate shaft 402. A distal end of cable 434 is preferably coupled to sensor 420 and a proximal end of cable 434 is preferably coupled to an instrument which is adapted to display and/or record a signal from sensor 420. It is to be appreciated, that cable 434 may include any number of conductors. In some applications, the number of conductors may be selected to match sensor 420. For example, sensor 420 may comprise a thermocouple having two contacts which are coupled to two conductors of cable 434.

FIG. 7 is a perspective view of a catheter 500 in accordance with still another exemplary embodiment of the present invention. Catheter 500 comprises an elongate shaft 502 having a distal end 504, a proximal end (not shown in FIG. 7) and an outer surface 506. A body member 530 of catheter 500 is disposed about elongate shaft 502. Body member 530 defines a plurality of flow channels 536.

In the embodiment of FIG. 7, a sensor 520 is disposed within each flow channel 536. Catheter 500 also includes a reference sensor 521 disposed proximate distal end 504 of elongate shaft 502. Sensors 520 and 521 preferably comprise temperature sensors. Examples of temperature sensors which may be suitable in some applications include resistance temperature devices (RTD's), thermistors, and thermocouples.

Catheter 500 may be used for mapping the locations of vulnerable plaque deposits within a blood vessel. Body member 530 is preferably sized so that an outer surface 505 of body member 530 is disposed proximate the inner surface of a blood vessel. When this is the case, blood flowing proximate the inner surface of the blood vessel will flow into the channels. Sensors 520 may be used to measure the temperature of the blood flowing through the channels. Blood which flows over a vulnerable plaque deposit will be warmed by the vulnerable plaque deposit. The increased temperature of this blood may be observed and/or recorded using sensors 520.

As catheter 500 is moved proximally and/or distally through a blood vessel, the distal end of body member 530

will be proximate different portions of the inner surface of the blood vessel. Variations in the signals from the sensors may be noted as catheter **500** is moved proximally and/or distally through the blood vessel, and these variations may be correlated with the axial position of catheter **500**. This information may be used to identify an axial component of the position of any vulnerable plaque deposits in the blood vessel.

In FIG. 7, it may be appreciated that flow channels **536** and sensors **520** are disposed radially about elongate shaft **502**. An angular component of the position of plaque deposits within the blood vessel may be identified by observing variations between the signals from the different sensors **520**. For example, sensors **520** which are proximate vulnerable plaque deposits may read higher temperatures than sensors **520** which are not proximate vulnerable plaque deposits.

FIG. 8 is a perspective view of a catheter **600** in accordance with still another exemplary embodiment of the present invention. Catheter **600** may be used for mapping the locations of vulnerable plaque deposits within a blood vessel. Catheter **600** comprises an elongate shaft **602** having a distal end **604**, a proximal end (not shown in FIG. 8) and an outer surface **606**. A sensor **620** is disposed so that it overlays outer surface **606** of elongate shaft **602**. In the embodiment of FIG. 8, sensor **620** comprises a flexible substrate **640** and a conductive path **638**. Conductive path **638** is coupled to a first conductor **642** and a second conductor **644**. In a preferred embodiment, the electrical resistance of conductive path **638** varies with temperature. Also in a preferred embodiment, first conductor **642** and second conductor **644** are insulated. First conductor **642** and second conductor **644** may be insulated, for example, by a layer of shrink tubing overlaying elongate shaft **602**. In the embodiment of FIG. 8, sensor **620** has a generally cylindrical outer surface **605**. In a preferred embodiment, the shape of outer surface **605** is selected so that sensor **620** contacts the inner surface of a blood vessel across a substantial area.

FIG. 9 is a perspective view of a catheter **700** in accordance with still another exemplary embodiment of the present invention. Catheter **700** may be used for mapping the locations of vulnerable plaque deposits within a blood vessel. Catheter **700** comprises an elongate shaft **702** having a distal end **704**, a proximal end (not shown in FIG. 9) and an outer surface **706**. Catheter **700** also includes a sensor **720** disposed proximate distal end **704** of elongate shaft **702**. In the embodiment of FIG. 9, sensor **720** comprises a body **746** having a generally cylindrical shape. In a preferred embodiment, the shape of body **746** is selected so that sensor **720** contacts the inner surface of a blood vessel across a substantial area. A first conductor **742** and a second conductor **744** are coupled to sensor **720**. In a preferred embodiment, a temperature recording and displaying instrument may interrogate sensor **720** via first conductor **742** and second conductor **744**.

FIG. 10 is a cross sectional perspective view of a catheter **800** in accordance with still another exemplary embodiment of the present invention. Catheter **800** comprises an elongate shaft **802** having an outer surface **806**. An interstitial member such as balloon **850** of catheter **800** is disposed about elongate shaft **802**.

Catheter **800** also includes an array **852** comprising plurality of cowls **854** circumferentially disposed about balloon **850**. Cowls **854** are preferably fixed to balloon **850**. Each cowl **854** defines an inlet port **856**, an outlet port **858**, and a flow channel **836** extending therebetween.

A sensor **820** (not shown in FIG. 10) is preferably disposed within each flow channel **836**. Each sensor **820** preferably comprises a temperature sensor. Examples of temperature sensors which may be suitable in some applications include resistance temperature devices (RTD's), thermistors, and thermocouples.

Balloon **850** preferably has an inflated state and a deflated state. In the embodiment of FIG. 10, balloon **850** is disposed outside of a blood vessel, and is shown in an inflated state. In a preferred embodiment, balloon **850** is configured such that cowls **854** are urged radially away from elongate shaft **802** when balloon **850** is in the inflated state. Alternatively, the cowls may be radially extended by a different mechanical mechanism, such as by a plurality of resilient arms, each arm being attached at one end to a cowl **854** and at an opposite end to the elongate shaft **802**.

FIG. 11 is a cross sectional plan view of catheter **800** of FIG. 10. In FIG. 11, a sensor **820** may be seen disposed within each flow channel **836**. Each flow channel **836** is defined by a cowl **854** that is preferably fixed to balloon **850**. Balloon **850** is disposed about elongate shaft **802**.

In the embodiment of FIG. 11, balloon **850** is disposed outside of a blood vessel, and is shown in an inflated state. Balloon **850** may be inflated, for example, by urging a fluid through an inflation lumen **860** and an inflation port **862** defined by elongate shaft **802**.

Balloon **850** is preferably configured such that cowls **854** will be urged against the inner surface of a blood vessel when balloon **850** is placed in the inflated state while catheter **800** is disposed within the blood vessel. Balloon **850** is preferably configured such that blood flow around cowls **854** will be precluded when balloon **850** is in the inflated state.

Blood flowing proximate the inner surface of the blood vessel preferably flows through flow channels **836** defined by cowls **854**. Sensors **820** may be used to measure the temperature of the blood flowing through the channels. Blood which flows over a vulnerable plaque deposit will be warmed by the vulnerable plaque deposit. The increased temperature of this blood may be observed and/or recorded using sensors **820**.

FIG. 12 is a cross sectional plan view of a catheter **900** in accordance with yet another exemplary embodiment of the present invention. Catheter **900** comprises an elongate shaft **902** having an outer surface **906**. A balloon **950** of catheter **900** is disposed about elongate shaft **902**.

Catheter **900** also includes an array **952** comprising plurality of cowls **954** circumferentially disposed about balloon **950**. In the embodiment of FIG. 12, each cowl has a generally wedge shaped cross-sectional shape. Each cowl **954** is preferably fixed to balloon **950**.

Each cowl **954** defines a flow channel **936**. A sensor **920** is preferably disposed within each flow channel **936**. Each sensor **920** preferably comprises a temperature sensor. Examples of temperature sensors which may be suitable in some applications include resistance temperature devices (RTD's), thermistors, and thermocouples.

Balloon **950** preferably has an inflated state and a deflated state. In the embodiment of FIG. 12, balloon **950** is disposed within a blood vessel **20**, and is shown in an inflated state. In a preferred embodiment, balloon **950** is configured such that cowls **954** are urged radially away from elongate shaft **902** when balloon **950** is in the inflated state. In FIG. 12, it may be appreciated that cowls **954** have been urged against an inner surface **24** of blood vessel **20** by balloon **950**. Balloon **950** may be inflated, for example, by urging a fluid

through an inflation lumen **960** and an inflation port **962** defined by elongate shaft **902**.

Balloon **950** is preferably configured such that blood flow around cowls **954** will be precluded when balloon **950** is in the inflated state. Blood flowing proximate inner surface **24** of blood vessel **20** preferably flows into flow channels **936** defined by cowls **954**. Sensors **920** may be used to measure the temperature of the blood flowing through the channels. Blood which flows over a vulnerable plaque deposit will be warmed by the vulnerable plaque deposit. The increased temperature of this blood may be observed and/or recorded using sensors **920**.

Having thus described the preferred embodiments of the present invention, those of skill in the art will readily appreciate that yet other embodiments may be made and used within the scope of the claims hereto attached. Numerous advantages of the invention covered by this document have been set forth in the foregoing description. It will be understood, however, that this disclosure is, in many respects, only illustrative. Changes may be made in details, particularly in matters of shape, size, and arrangement of parts without exceeding the scope of the invention. The invention's scope is, of course, defined in the language in which the appended claims are expressed.

What is claimed is:

1. A catheter for mapping vulnerable plaque deposits within a blood vessel, comprising;
 - an elongate shaft having a proximal end and a distal end; at least one cowl fixed to the elongate shaft proximate the distal end thereof;
 - the at least one cowl defining an inlet port, an outlet port, and a fluid flow channel extending therebetween; and
 - at least one temperature sensor disposed within the flow channel defined by the at least one cowl.
2. The catheter of claim **1**, wherein the at least one temperature sensor is adapted to measure the temperature of blood passing through the flow channel.
3. The catheter of claim **1**, wherein the at least one temperature sensor is adapted to measure the temperature of blood passing through the flow channel; and
 - the at least one cowl is configured such that the temperature of the blood passing through the flow channel is reflective of the temperature of an inner surface of the blood vessel proximate the distal end; of the catheter.
4. The catheter of claim **1**, wherein the temperature sensor comprises a resistance temperature device.
5. The catheter of claim **1**, wherein the temperature sensor comprises a thermocouple.
6. The catheter of claim **1**, wherein the temperature sensor comprises a thermistor.
7. The catheter of claim **1**, wherein the temperature sensor comprises a microbolometer.
8. The catheter of claim **1**, further comprising an interstitial member disposed between the at least one cowl and the elongate shaft.
9. The catheter of claim **1**, further comprising a balloon disposed between the at least one cowl and the elongate shaft.
10. The catheter of claim **9**, wherein the balloon has an inflated state and a deflated state.
11. The catheter of claim **10**, wherein the balloon is configured such that flow of blood around the at least one cowl is precluded when the balloon is in the inflated state.
12. The catheter of claim **10**, wherein the balloon is configured such that the at least one cowl is urged radially away from the elongate shaft when the balloon is in the inflated state.

13. The catheter of claim **1**, further comprising a plurality of cowls radially disposed about the elongate shaft.

14. A catheter for mapping vulnerable plaque deposits within a blood vessel, comprising;

- an elongate shaft having a proximal end and a distal end;
- a plurality of cowls radially disposed about the elongate shaft proximate the distal end thereof;
- each cowl defining an inlet port, an outlet port, and a fluid flow channel extending therebetween; and
- a temperature sensor disposed within each flow channel.

15. The catheter of claim **14**, wherein each temperature sensor comprises a resistance temperature device.

16. The catheter of claim **14**, wherein each temperature sensor comprises a thermocouple.

17. The catheter of claim **14**, wherein each temperature sensor comprises a thermistor.

18. The catheter of claim **14**, wherein each temperature sensor comprises a microbolometer.

19. The catheter of claim **14**, further comprising an interstitial member disposed between the cowls and the elongate shaft.

20. The catheter of claim **14**, further comprising a balloon disposed between the plurality of cowls and the elongate shaft.

21. The catheter of claim **20**, wherein the balloon has an inflated state and a deflated state.

22. The catheter of claim **21**, wherein the balloon is configured such that flow of blood around the cowls is precluded when the balloon is in the inflated state.

23. The catheter of claim **21**, wherein the balloon is configured such that the cowls are urged radially away from the elongate shaft when the balloon is in the inflated state.

24. A catheter for mapping vulnerable plaque deposits within a blood vessel, comprising;

- an elongate shaft having a proximal end and a distal end;
- an array of cowls radially disposed about the elongate shaft proximate the distal end thereof;
- each cowl of the array of cowls defining an inlet port, an outlet port, and a fluid flow channel extending therebetween;
- a temperature sensor disposed within each flow channel; and
- a means for radially expanding the array of cowls.

25. The catheter of claim **24**, wherein each temperature sensor comprises a resistance temperature device.

26. The catheter of claim **24**, wherein each temperature sensor comprises a thermocouple.

27. The catheter of claim **24**, wherein each temperature sensor comprises a thermistor.

28. The catheter of claim **24**, wherein each temperature sensor comprises a microbolometer.

29. The catheter of claim **24**, wherein the means for radially expanding the array of cowls comprises a hydraulic mechanism.

30. The catheter of claim **29**, wherein the hydraulic mechanism comprises a balloon.

31. The catheter of claim **30**, wherein the balloon is configured such that flow of blood around the cowls is precluded when the balloon is in an inflated state.

32. The catheter of claim **24**, wherein the means for radially expanding the array of cowls comprises a mechanical mechanism.

33. The catheter of claim **24**, wherein the means for radially expanding the array of cowls comprises a plurality of resilient arms.

专利名称(译)	血管内温度传感器		
公开(公告)号	US6514214	公开(公告)日	2003-02-04
申请号	US09/782502	申请日	2001-02-13
申请(专利权)人(译)	SCIMED LIFE SYSTEMS INC.		
当前申请(专利权)人(译)	BOSTON SCIENTIFIC SCIMED , INC.		
[标]发明人	KOKATE JAYDEEP Y DOBRAVA ERIC M BERRADA MARWANE S KIMMEL SCOTT PRSTIC SUZANA HOEY MICHAEL F BAR COHEN AVRAM IAIZZO PAUL A		
发明人	KOKATE, JAYDEEP Y. DOBRAVA, ERIC M. BERRADA, MARWANE S. KIMMEL, SCOTT PRSTIC, SUZANA HOEY, MICHAEL F. BAR-COHEN, AVRAM IAIZZO, PAUL A.		
IPC分类号	A61B5/00 A61B17/22 A61B17/00 A61B5/01 A61F2/82		
CPC分类号	A61B5/01 A61B5/6852 A61B5/6853 A61B5/6859 A61B5/6885 A61B5/6858 A61B2017/22051 A61B2017/00101		
审查员(译)	刨 , KEVIN		
其他公开文献	US20020111560A1		
外部链接	Espacenet USPTO		

摘要(译)

公开了用于检测血管内易损斑块的装置和方法。根据本发明的导管包括细长轴，该细长轴具有近端，远端和外表面。至少一个温度传感器设置在细长轴的远端附近。在一个优选实施例中，至少一个温度传感器适于接触血管的内表面。在另一个优选实施例中，至少一个温度传感器设置在由主体构件限定的通道内，该主体构件围绕细长轴设置。

