



(19) **United States**

(12) **Patent Application Publication**
Schulman et al.

(10) **Pub. No.: US 2008/0092911 A1**

(43) **Pub. Date: Apr. 24, 2008**

(54) **SYSTEM FOR MONITORING TEMPERATURE**

(76) Inventors: **Joseph H. Schulman**, Santa Clarita, CA (US); **John C. Gord**, Venice, CA (US); **James H. Wolfe**, Canyon Country, CA (US)

Correspondence Address:
ALFRED E. MANN FOUNDATION FOR SCIENTIFIC RESEARCH
PO BOX 905
SANTA CLARITA, CA 91380

(21) Appl. No.: **10/920,570**

(22) Filed: **Aug. 18, 2004**

Related U.S. Application Data

(60) Continuation-in-part of application No. 10/391,424, filed on Mar. 17, 2003, which is a division of application No. 09/677,384, filed on Sep. 30, 2000, now Pat. No. 6,564,807, which is a division of application No. 09/048,827, filed on Mar. 25, 1998, now Pat. No. 6,164,284, which is a continuation-in-part of application No. 09/030,106, filed on Feb. 25, 1998, now Pat. No. 6,185,452.

(60) Provisional application No. 60/497,392, filed on Aug. 22, 2003, provisional application No. 60/039,164, filed on Feb. 26, 1997, provisional application No. 60/042,447, filed on Mar. 27, 1997.

Publication Classification

(51) **Int. Cl.**
A61B 19/00 (2006.01)

(52) **U.S. Cl.** **128/899; 600/549; 607/60**

(57) **ABSTRACT**

A system for monitoring temperature in a body, the system comprising at least one implantable device, wherein the implantable device(s) is operable to sense temperature in the body and to generate status signals based on the sensed temperature in the body. The system further comprising a system control unit for wirelessly communicating with the implantable device(s), and the system control unit comprising a signal receiver for receiving the status signals, and also a programmable controller for producing notification signals based on the received status signals. A notification unit can alternatively communicate with the system control unit or the implantable device(s) for disclosing the sensed body temperature based on the notification signals.

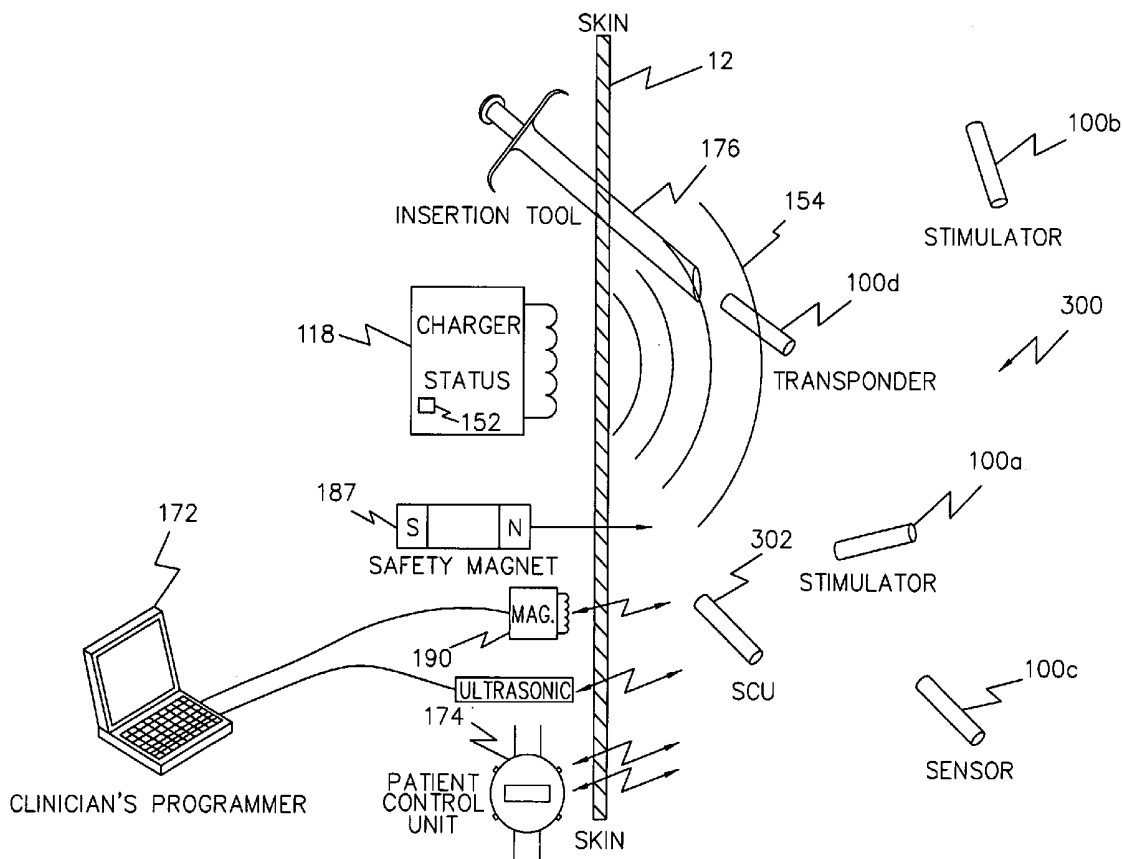

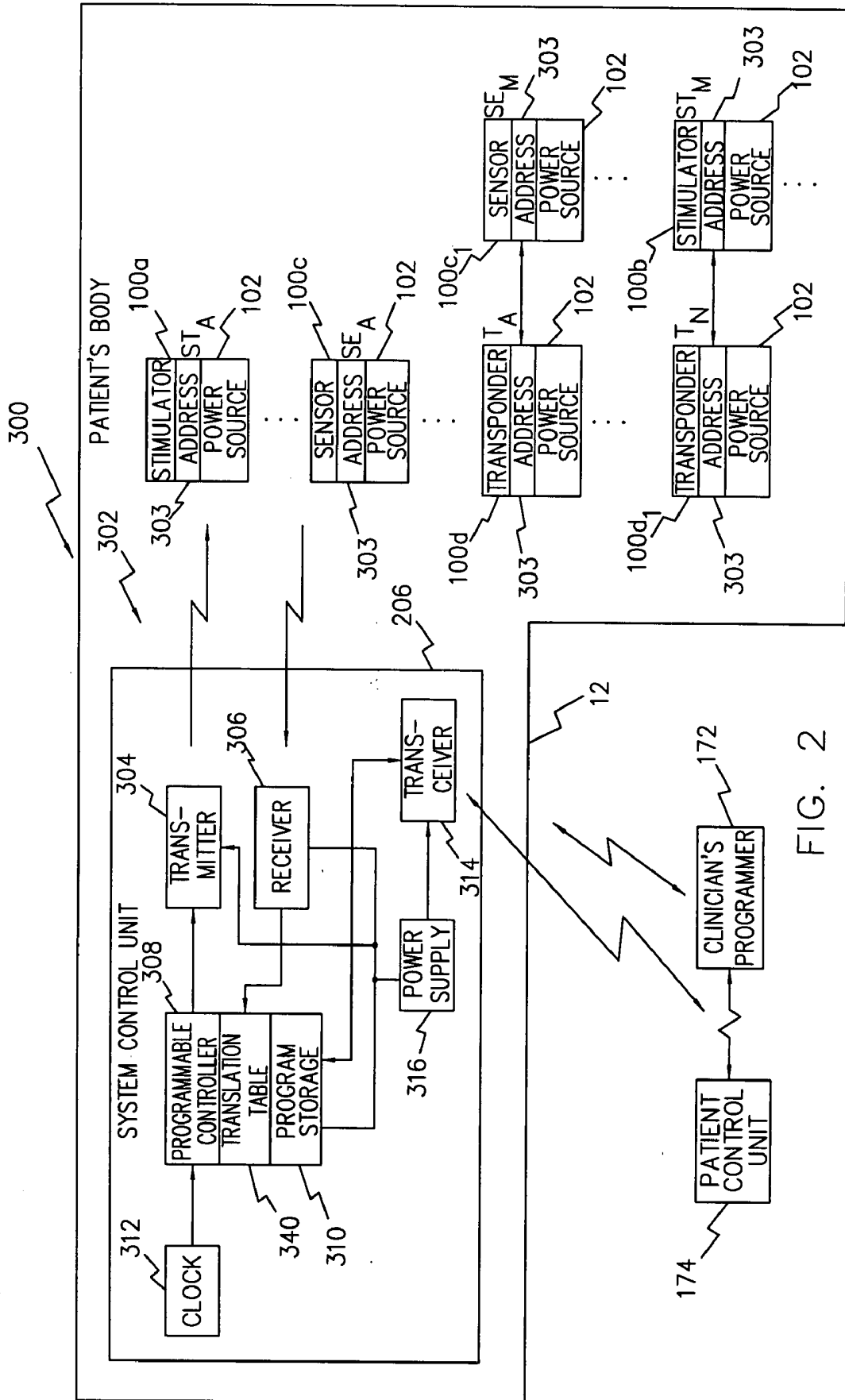

FIG. 2

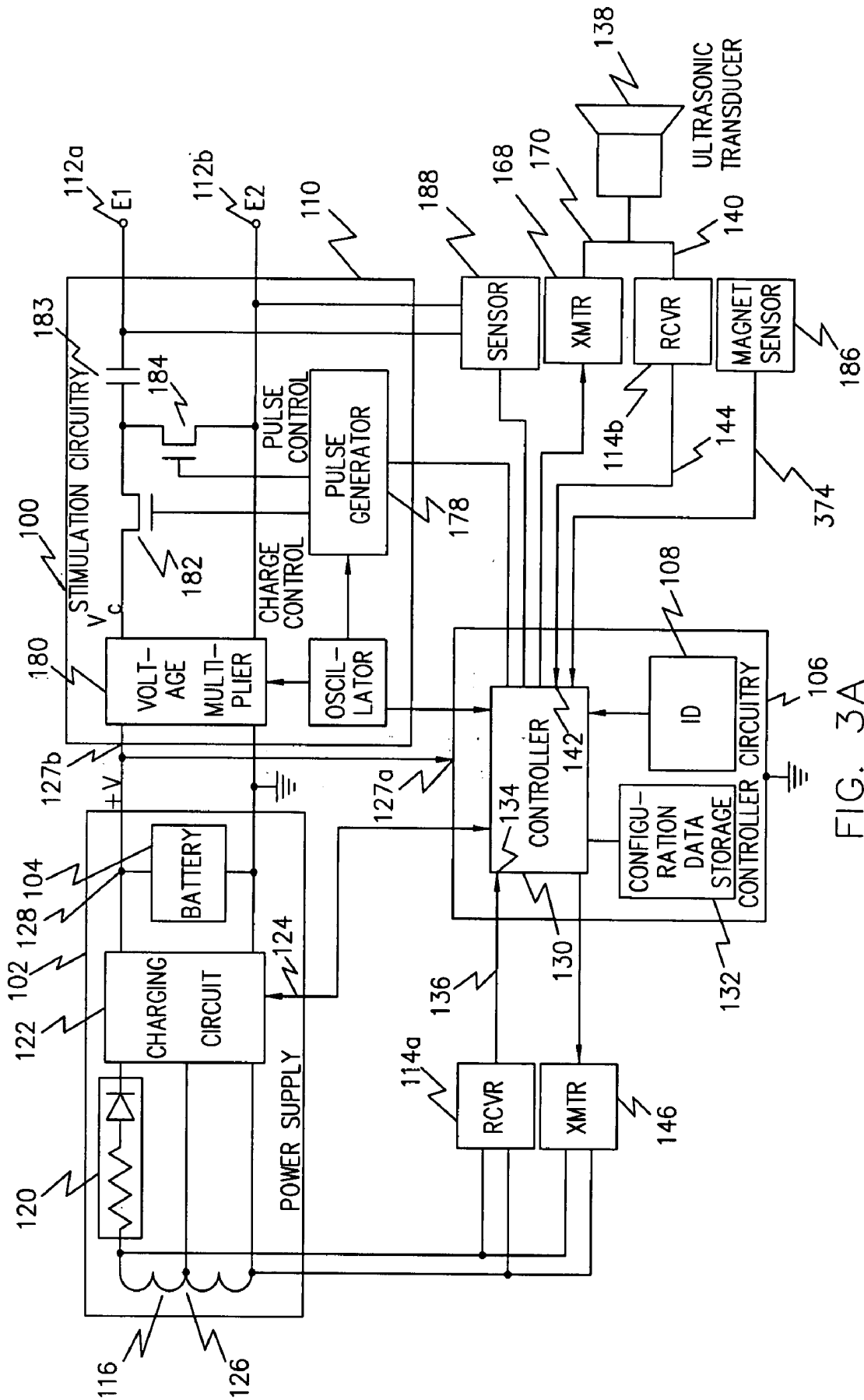

FIG. 3A

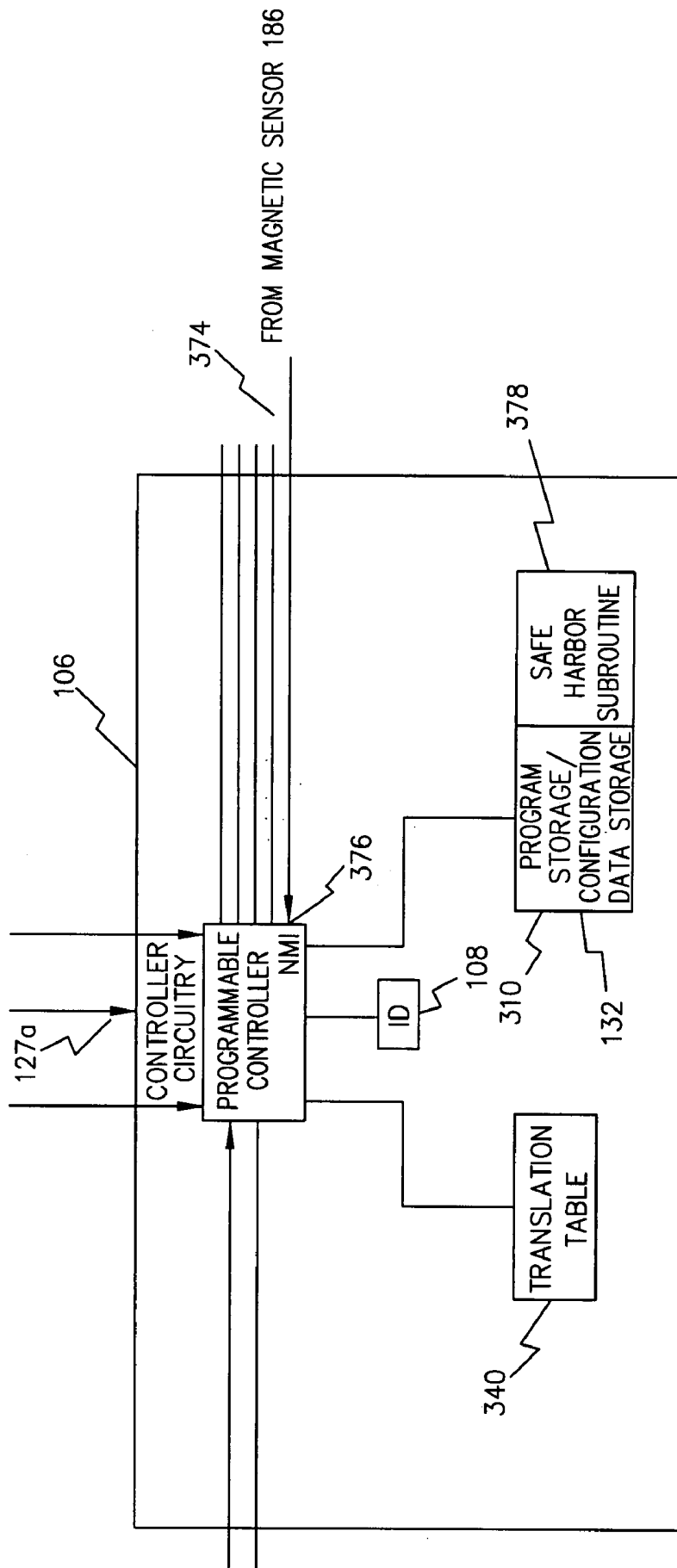

FIG. 3B

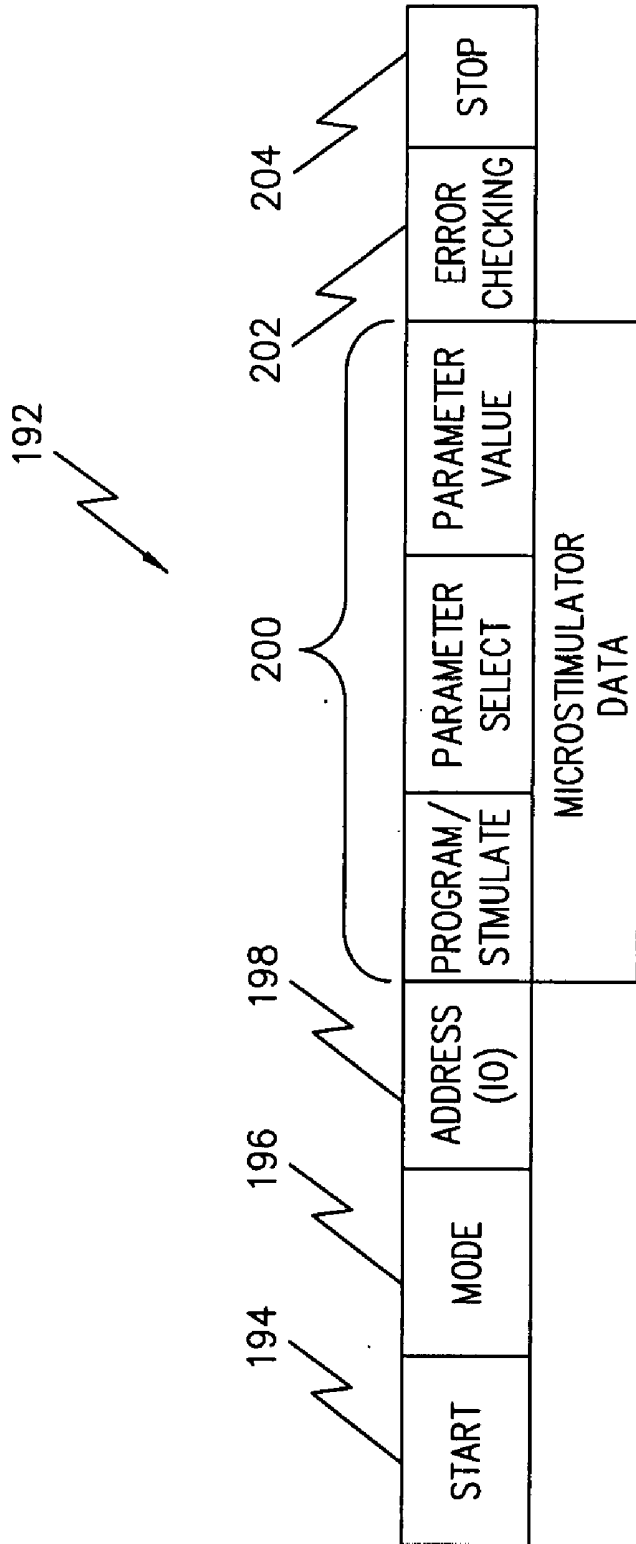
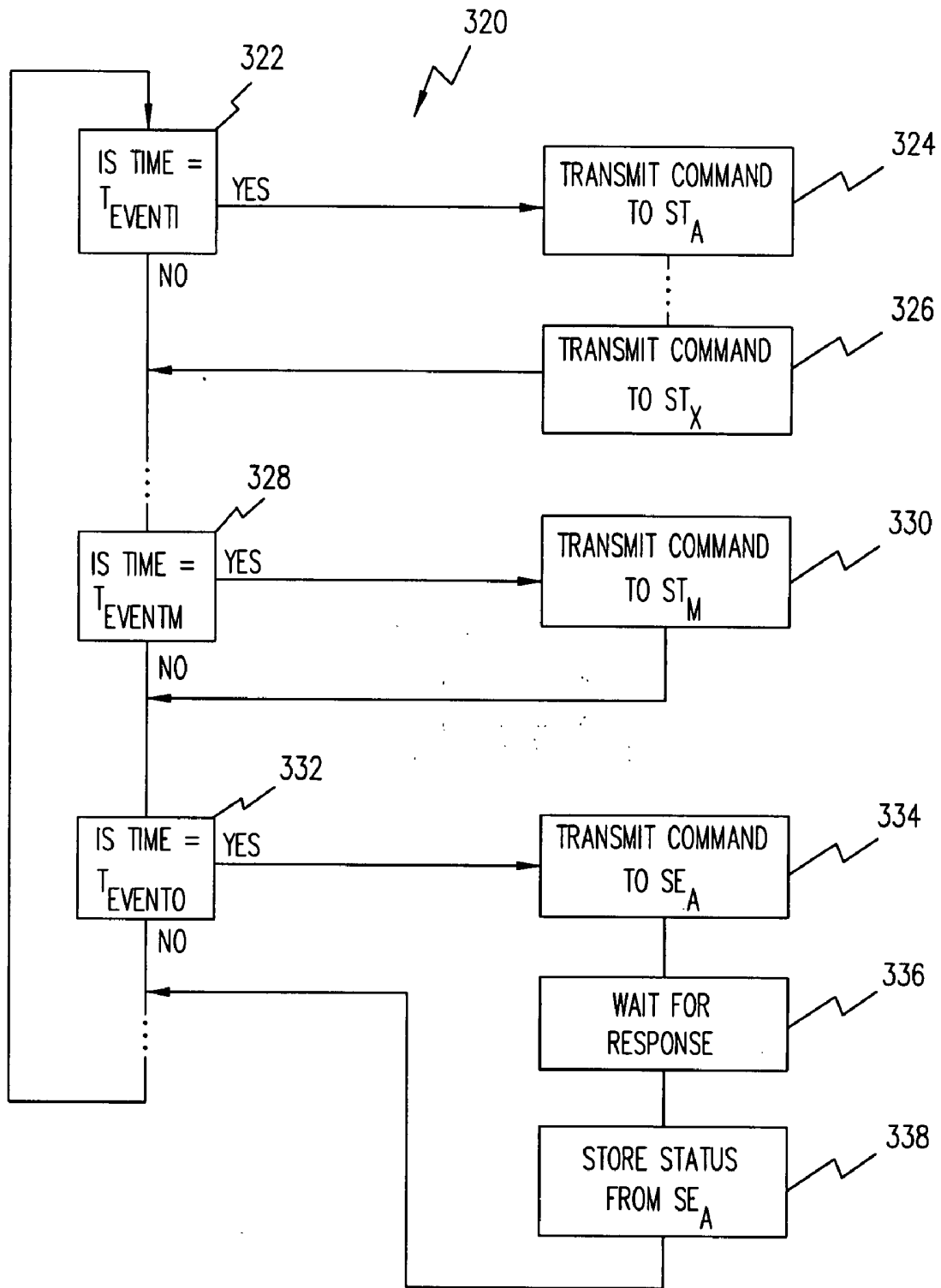
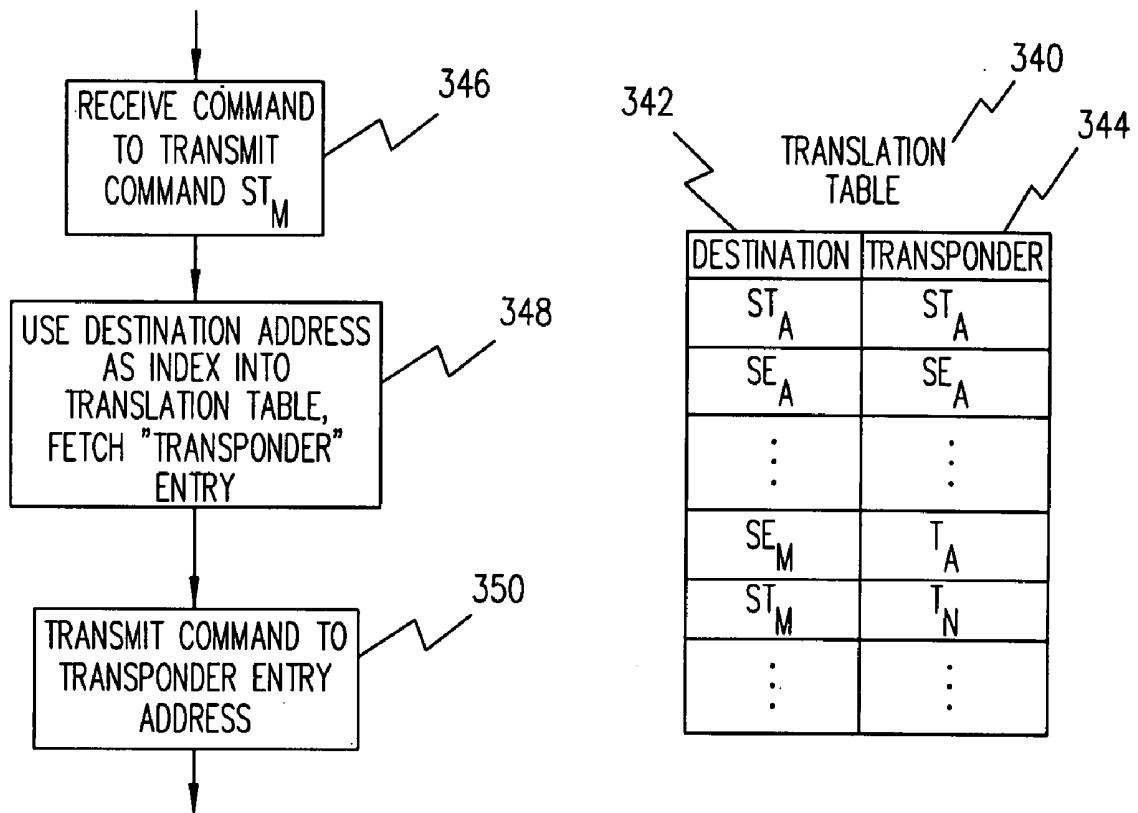

FIG. 4



OPEN LOOP CONTROL/MONITOR

FIG. 5



OPTIONAL USE OF
TRANSLATION TABLE

FIG. 6

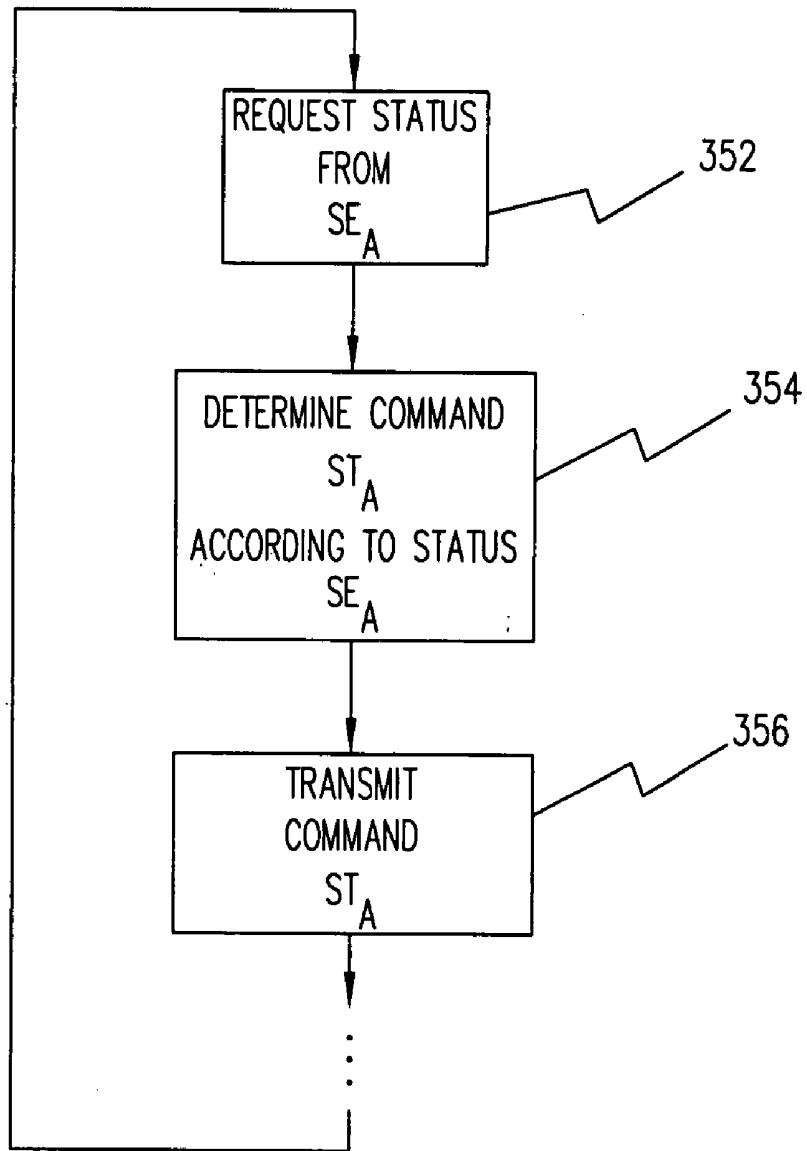

CLOSED LOOP CONTROL

FIG. 7

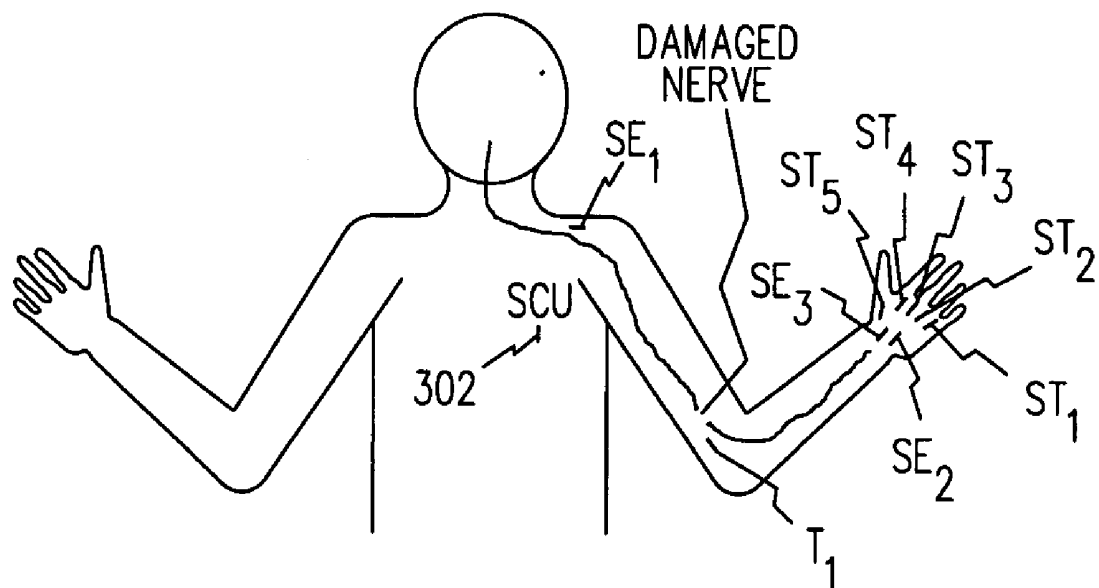

EXEMPLARY INJURY

FIG. 8

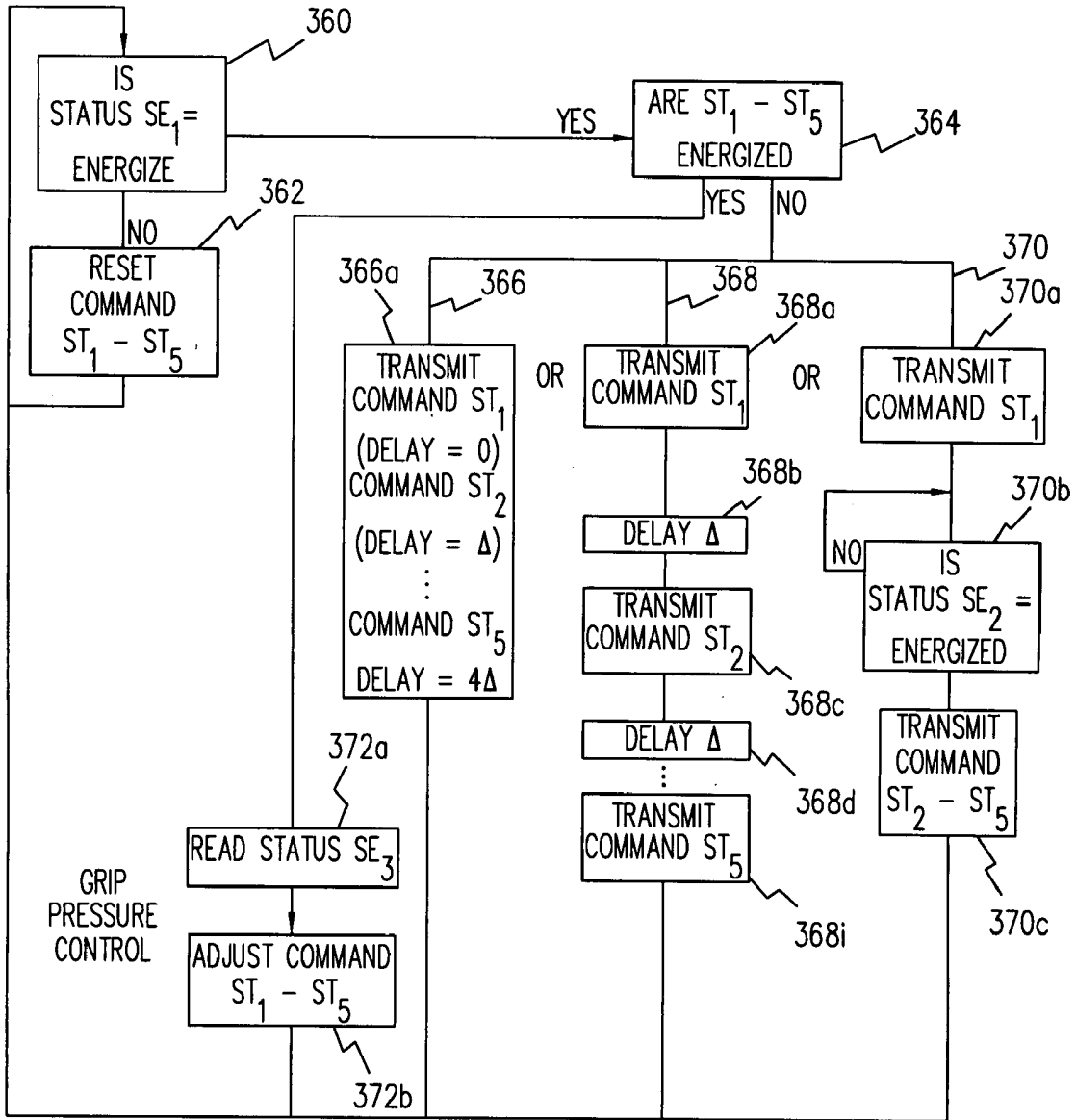

COORDINATED CLOSED LOOP HAND CONTROL

FIG. 9

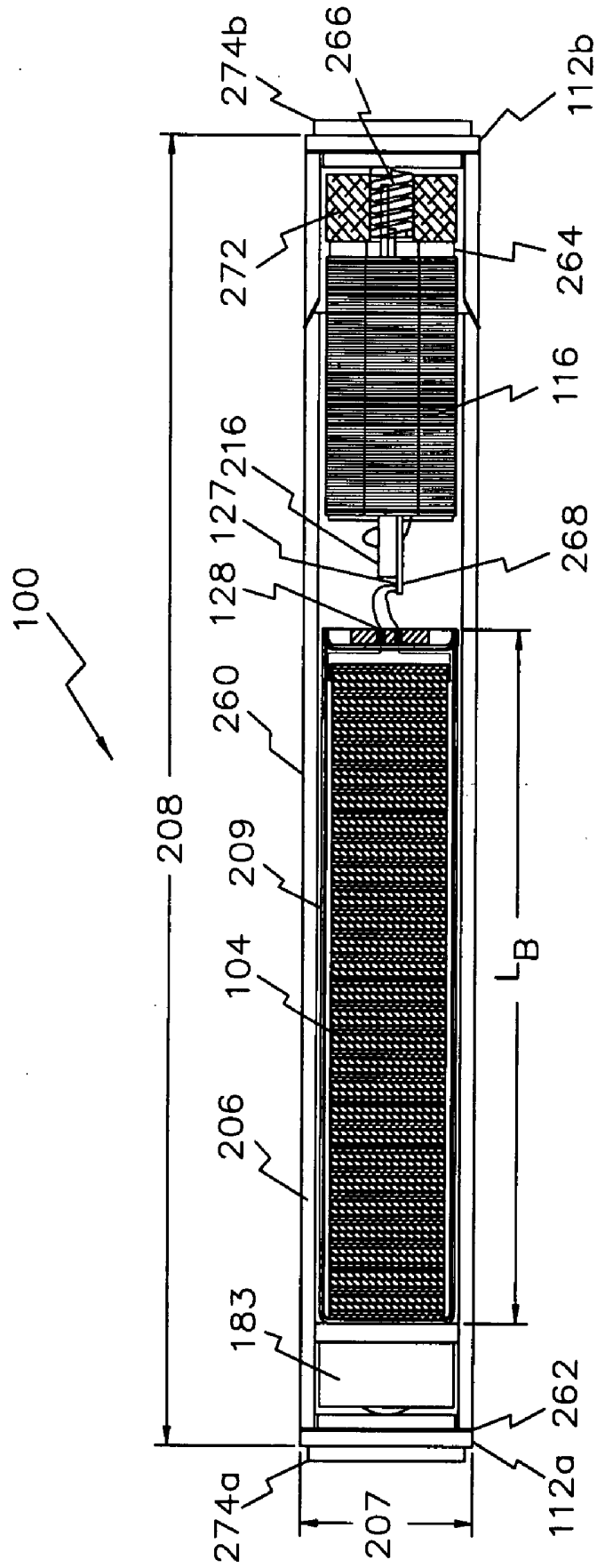

FIG. 10A

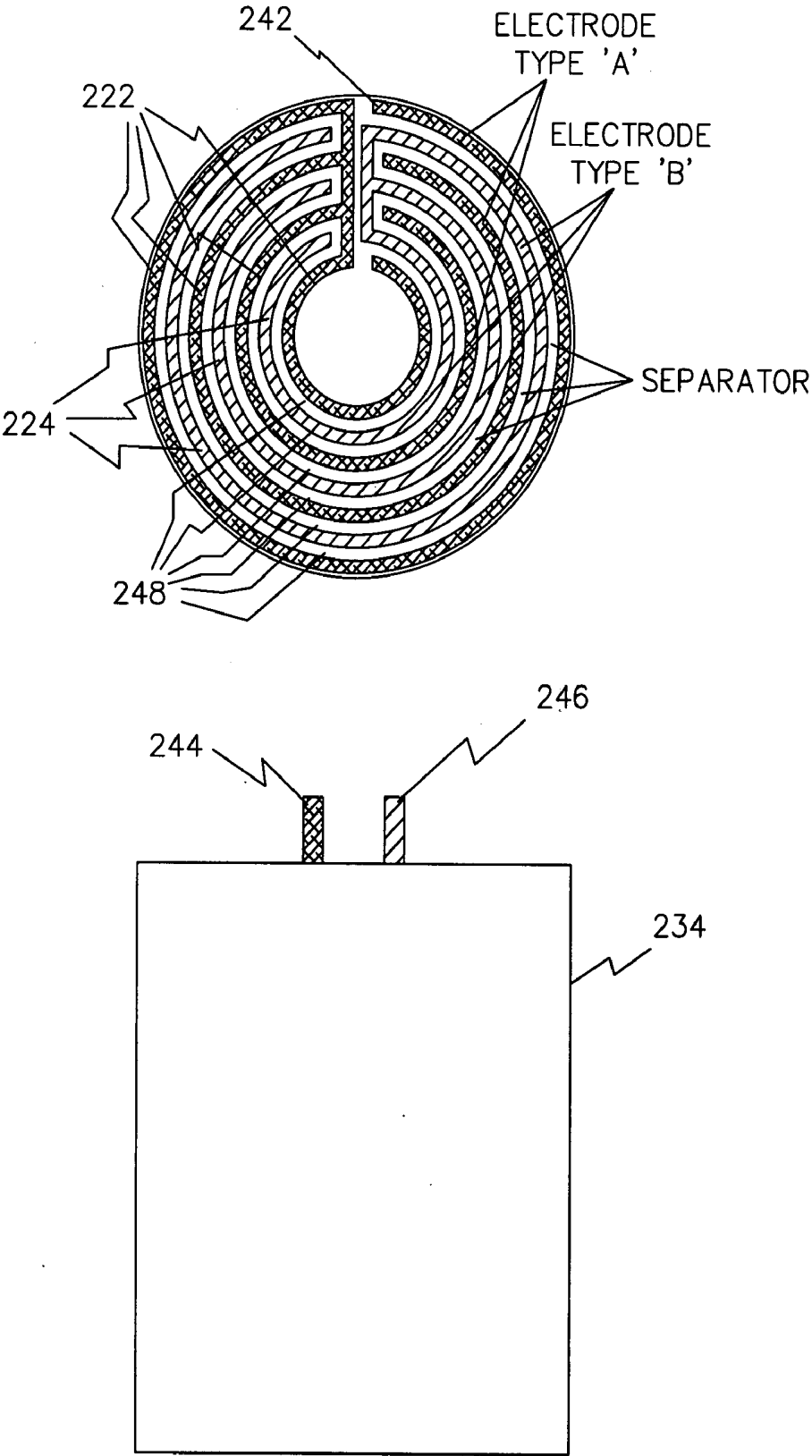

FIG. 11

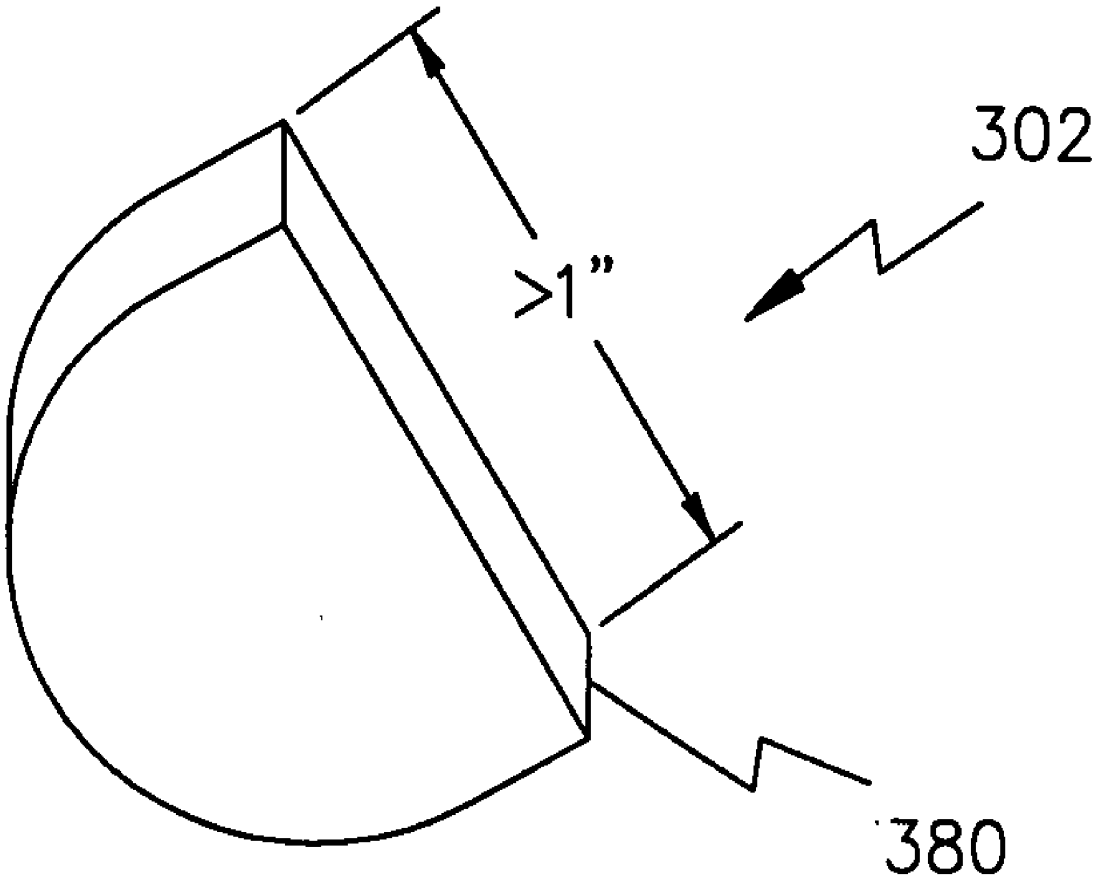

FIG. 12

SYSTEM FOR MONITORING TEMPERATURE

[0001] This application is a continuation-in-part of U.S. patent application Ser. No. 10/391,424, filed Mar. 17, 2003, which in turn is a divisional of U.S. patent application Ser. No. 09/677,384, filed Sep. 30, 2000, now U.S. Pat. No. 6,564,807, which in turn is a divisional of U.S. patent application Ser. No. 09/048,827, filed Mar. 25, 1998, now U.S. Pat. No. 6,164,284, which in turn claims the benefit of U.S. Provisional Application No. 60/042,447, filed Mar. 27, 1997; and a continuation-in-part of U.S. patent application Ser. No. 09/030,106, filed Feb. 25, 1998, now U.S. Pat. No. 6,185,452, which in turn claims the benefit of U.S. Provisional Application No. 60/039,164 filed Feb. 26, 1997. This application also claims the benefit of U.S. Provisional Application No. 60/497,392 filed Aug. 22, 2003.

BRIEF DESCRIPTION OF THE DRAWINGS

[0002] FIG. 1 is a simplified block diagram of the system of the present embodiments comprised of implantable devices, e.g., microstimulators, microsensors and microtransponders, under control of an implantable system control unit (SCU);

[0003] FIG. 2 comprises a block diagram of the system of FIG. 1 showing the functional elements that form the system control unit and implanted microstimulators, microsensors and microtransponders;

[0004] FIG. 3A comprises a block diagram of an exemplary implantable device including a battery for powering the device for a period of time in excess of one hour in response to a command from the system control unit;

[0005] FIG. 3B comprises a simplified block diagram of controller circuitry that can be substituted for the controller circuitry of FIG. 3A, thus permitting a single device to be configured as a system control unit and/or a microstimulator and/or a microsensor and/or a microtransponder;

[0006] FIG. 4 is a simplified diagram showing the basic format of data messages for commanding/interrogating the implantable microstimulators, microsensors and microtransponders which form a portion of the present embodiments;

[0007] FIG. 5 shows an exemplary flow chart of the use of the present system in an open loop mode for controlling/monitoring a plurality of implantable devices, e.g., microstimulators, microsensors;

[0008] FIG. 6 shows a flow chart of the optional use of a translation table for communicating with microstimulators and/or microsensors via microtransponders;

[0009] FIG. 7 shows a simplified flow chart of the use of closed loop control of a microstimulator by altering commands from the system control unit in response to status data received from a microsensor;

[0010] FIG. 8 shows an exemplary injury, i.e., a damaged nerve, and the placement of a plurality of implantable devices, i.e., microstimulators, microsensors and a microtransponder under control of the system control unit for "replacing" the damaged nerve;

[0011] FIG. 9 shows a simplified flow chart of the control of the implantable devices of FIG. 8 by the system control unit;

[0012] FIGS. 10A and 10B show two side cutaway views of the present embodiment of an implantable ceramic tube

suitable for the housing the system control unit and/or microstimulators and/or microsensors and/or microtransponders;

[0013] FIG. 11 illustrates an exemplary battery suitable for powering the implantable devices which comprise the components of the present embodiment; and

[0014] FIG. 12 shows an exemplary housing suitable for an implantable SCU having a battery enclosed within that has a capacity of at least 1 watt-hour.

DESCRIPTION OF THE PREFERRED EMBODIMENTS

[0015] The present invention relates to systems for monitoring and/or affecting parameters of a patient's body for the purpose of medical diagnosis and/or treatment. More particularly, systems in accordance with the invention are characterized by a plurality of devices, preferably battery-powered, configured for implanting within a patient's body, each device being configured to sense a body parameter, e.g., temperature. and/or to affect a parameter, e.g., via nerve stimulation.

[0016] Each of the plurality of devices are a microelectronic device which can be a microstimulator and/or a microsensor and/or a System Control Unit (described below). For example, a class of injectable/implantable microelectronic devices described in U.S. Pat. Nos. 5,193,539, 5,193,540, 5,312,439, 6,164,284, 6,185,452, 6,208,894, 6,315,721, 6,564,807 and incorporated by reference herein provide for stimulation of biological tissue or sensing of signals from biological tissue such as nerves or muscles as well as physiologic parameters such as body temperature. Each device includes electrical stimulation circuitry and electrodes configured in a form that is suitable for injection by means of a hypodermic needle or insertion tool. The devices can be leadless or have leads attached to them. Furthermore, each device may communicate through wireless or wired communication networks. In the case of wireless networks, microelectronic devices receive power by either inductive coupling to an externally applied electromagnetic field or by means of an internal rechargeable battery. They receive digital command signals by telemetry. The packaging and materials of the microelectronic device are selected and designed to protect its electronic circuitry from the body fluids and to avoid damage to the electrodes and the surrounding tissues from the presence and operation of the microelectronic device in those tissues. In this regard the microelectronic devices are hermetically sealed and unaffected by body fluids.

[0017] Applicants' application Ser. No. 09/030,106, now issued as U.S. Pat. No. 6,185,452 (hereafter referred to as "U.S. Pat. No. 6,185,452") entitled "Battery Powered Patient Implantable Device", incorporated herein by reference, describes devices configured for implantation within a patient's body, i.e., beneath a patient's skin, for performing various functions including: (1) stimulation of body tissue, (2) sensing of body parameters, and (3) communicating between implanted devices and devices external to a patient's body.

[0018] The present invention is directed to a system for monitoring and/or affecting parameters of a patient's body and more particularly to such a system comprised of a system control unit (SCU) and one or more devices implantable in the patient's body, i.e., within the envelope defined by the patient's skin. Each said implantable device is con-

figured to be monitored and/or controlled by the SCU via a wireless communication channel.

[0019] In accordance with the invention, the SCU comprises a programmable unit capable of (1) transmitting commands to at least some of a plurality of implantable devices and (2) receiving data signals from at least some of those implantable devices. In accordance with an embodiment, the system operates in closed loop fashion whereby the commands transmitted by the SCU are dependent, in part, on the content of the data signals received by the SCU.

[0020] In accordance with an embodiment, each implantable device is configured similarly to the devices described in U.S. Pat. No. 6,185,452 and typically comprises a sealed housing suitable for injection into the patient's body. Each housing contains a power source having a capacity of at least 1 microwatt-hour, a rechargeable battery, and power consuming circuitry preferably including a data signal transmitter and receiver and sensor/stimulator circuitry for driving an input/output transducer.

[0021] In accordance with an aspect of the embodiment, an SCU is also implemented as a device capable of being injected into the patient's body. Wireless communication between the SCU and the other implantable devices can be implemented in various ways, e.g., via a modulated sound signal, AC magnetic field, RF signal, or electrical conduction.

[0022] In accordance with a further aspect of the invention, the SCU is remotely programmable, e.g., via wireless means, to interact with the implantable devices according to a treatment regimen. In accordance with an embodiment, the SCU is powered via an internal power source, e.g., a rechargeable battery. Accordingly, an SCU combined with one or more battery-powered implantable devices, such as those described in the U.S. Pat. No. 6,185,452, form a self-sufficient system for treating a patient.

[0023] In accordance with an embodiment, the SCU and other implantable devices are implemented substantially identically, being comprised of a sealed housing configured to be injected into the patient's body. Each housing contains sensor/stimulator circuitry for driving an input/output transducer, e.g., an electrode, to enable it to additionally operate as a sensor and/or stimulator.

[0024] Alternatively, the SCU could be implemented as an implantable but non-injectable housing which would permit it to be physically larger enabling it to accommodate larger, higher capacity components, e.g., battery, microcontroller, etc. As a further alternative, the SCU could be implemented in a housing configured for carrying on the patient's body outside of the skin defined envelope, e.g., in a wrist band.

[0025] In accordance with the U.S. Pat. No. 6,185,452, the commands transmitted by the SCU can be used to remotely configure the operation of the other implanted devices and/or to interrogate the status of those devices. For example, various operating parameters, e.g., the pulse frequency, pulse width, trigger delays, etc., of each implanted device can be controlled or specified in one or more commands addressably transmitted to the device. Similarly, the sensitivity of the sensor circuitry and/or the interrogation of a sensed parameter, e.g., battery status, can be remotely specified by the SCU.

[0026] In accordance with a feature of the embodiment, the SCU and/or each implantable device includes a programmable memory for storing a set of default parameters. In the event of power loss, SCU failure, or any other

catastrophic occurrence, all devices default to the safe harbor default parameters. The default parameters can be programmed differently depending upon the condition being treated. In accordance with a further feature, the system includes a switch preferably actuatable by an external DC magnetic field, for resetting the system to its default parameters.

[0027] In an exemplary use of a system in accordance with the present embodiments, a patient with nerve damage can have a damaged nerve "replaced" by an implanted SCU and one or more implanted sensors and stimulators, each of which contains its own internal power source. In this exemplary system, the SCU would monitor a first implanted sensor for a signal originating from the patient's brain and responsively transmit command signals to one or more stimulators implanted past the point of nerve damage. Furthermore, the SCU could monitor additional sensors to determine variations in body parameters and, in a closed loop manner, react to control the command signals to achieve the desired treatment regimen.

[0028] The novel features of the invention are set forth with particularity in the appended claims. The invention will be best understood from the following description when read in conjunction with the accompanying drawings.

[0029] FIG. 1 (essentially corresponding to FIG. 2 of the U.S. Pat. No. 6,185,452) and FIG. 2 show an exemplary system 300 made of implantable devices 100, battery powered, under control of a system control unit (SCU) 302, also implantable beneath a patient's skin 12. As described in the U.S. Pat. No. 6,185,452 potential implantable devices 100 (see also the block diagram shown in FIG. 3A) include stimulators, e.g., 100a, sensors, e.g., 100c, and transponders, e.g., 100d. The stimulators, e.g., 100a, can be remotely programmed to output a sequence of drive pulses to body tissue proximate to its implanted location via attached electrodes. The sensors, e.g., 100c, can be remotely programmed to sense one or more physiological or biological parameters in the implanted environment of the device, e.g., temperature, glucose level, O₂ content, etc. Transponders, e.g., 100d, are devices which can be used to extend the interbody communication range between stimulators and sensors and other devices, e.g., a clinician's programmer 172 and the patient control unit 174. Preferably, these stimulators, sensors and transponders are contained in sealed elongate housing having an axial dimension of less than 60 mm and a lateral dimension of less than 6 mm. Accordingly, such stimulators, sensors and transponders are respectively referred to as microstimulators, microsensors, and microtransponders. Such microstimulators and microsensors can thus be positioned beneath the skin within a patient's body using a hypodermic type insertion tool 176.

[0030] As described in the U.S. Pat. No. 6,185,452, microstimulators and microsensors are remotely programmed and interrogated via a wireless communication channel, e.g., modulated AC magnetic, sound (i.e., ultrasonic), RF or electric fields, typically originating from control devices external to the patient's body, e.g., a clinician's programmer 172 or patient control unit 174. Typically, the clinician's programmer 172 is used to program a single continuous or one time pulse sequence into each microstimulator and/or measure a biological parameter from one or more microsensors. Similarly, the patient control unit 174 typically communicates with the implanted devices 100, e.g., microsensors 100c, to monitor biological parameters. In order to

distinguish each implanted device over the communication channel, each implanted device is manufactured with an identification code (ID) **303** specified in address storage circuitry **108** (see FIG. 3A) as described in the great grandparent application.

[0031] By using one or more such implantable devices in conjunction with the SCU **302** of the present embodiment, the capabilities of such implantable devices can be further expanded. For example, in an open loop mode (described below in reference to FIG. 5), the SCU **302** can be programmed to periodically initiate tasks, e.g., perform real time tasking, such as transmitting commands to microstimulators according to a prescribed treatment regimen or periodically monitor biological parameters to determine a patient's status or the effectiveness of a treatment regimen. Alternatively, in a closed loop mode (described below in reference to FIGS. 7-9), the SCU **302** periodically interrogates one or more microsensors and accordingly adjusts the commands transmitted to one or more microstimulators.

[0032] FIG. 2 shows the system **300** of the present embodiments comprised of (1) one or more implantable devices **100** operable to sense and/or stimulate a patient's body parameter in accordance with one or more controllable operating parameters and (2) the SCU **302**. The SCU **302** is primarily comprised of (1) a housing **206**, preferably sealed and configured for implantation beneath the skin of the patient's body as described in the U.S. Pat. No. 6,185,452, in reference to the implanted devices **100**, (2) a signal transmitter **304** in the housing **206** for transmitting command signals, (3) a signal receiver **306** in the housing **206** for receiving status signals, and (4) a programmable controller **308**, e.g., a microcontroller or state machine, in the housing **206** responsive to received status signals for producing command signals for transmission by the signal transmitter **304** to other implantable devices **100**. The sequence of operations of the programmable controller **308** is determined by an instruction list, i.e., a program, stored in program storage **310**, coupled to the programmable controller **308**. While the program storage **310** can be a nonvolatile memory device, e.g., ROM, manufactured with a program corresponding to a prescribed treatment regimen, it is contemplated that at least a portion of the program storage **310** be an alterable form of memory, e.g., RAM, EEPROM, etc., whose contents can be remotely altered as described further below. However, it is additionally preferable that a portion of the program storage **310** be nonvolatile so that a default program is always present. The rate at which the program contained within the program storage **310** is executed is determined by clock **312**, preferably a real time clock that permits tasks to be scheduled at specified times of day.

[0033] The signal transmitter **304** and signal receiver **306** preferably communicate with implanted devices **100** using sound means, i.e., mechanical vibrations, using a transducer having a carrier frequency modulated by a command data signal. In a preferred embodiment, a carrier frequency of 100 KHz is used which corresponds to a frequency that freely passes through a typical body's fluids and tissues. However, such sound means that operate at any frequency, e.g., greater than 1 Hz, are also considered to be within the scope of the present invention. Alternatively, the signal transmitter **304** and signal receiver **306** can communicate using modulated AC magnetic, RF, or electric fields.

[0034] The clinician's programmer **172** and/or the patient control unit **174** and/or other external control devices can

also communicate with the implanted devices **100**, as described in the U.S. Pat. No. 6,185,452, preferably using a modulated AC magnetic field. Alternatively, such external devices can communicate with the SCU **302** via a transceiver **314** coupled to the programmable controller **308**. Since, in a preferred operating mode, the signal transmitter **304** and signal receiver **306** operate using sound means, a separate transceiver **314** which operates using magnetic means is used for communication with external devices. However, a single transmitter **304**/receiver **306** can be used in place of transceiver **314** if a common communication means is used.

[0035] FIG. 3A comprises a block diagram of an exemplary implantable device **100** (as shown in FIG. 2 of the U.S. Pat. No. 6,185,452) which includes a battery **104**, preferably rechargeable, for powering the device for a period of time in excess of one hour and responsive to command signals from a remote device, e.g., the SCU **302**. As described in the U.S. Pat. No. 6,185,452, the implantable device **100** is configurable to alternatively operate as a microstimulator and/or microsensor and/or microtransponder due to the commonality of most of the circuitry contained therein. Such circuitry can be further expanded to permit a common block of circuitry to also perform the functions required for the SCU **302**. Accordingly, FIG. 3B shows an alternative implementation of the controller circuitry **106** of FIG. 3A that is suitable for implementing a microstimulator and/or a microsensor and/or a microtransponder and/or the SCU **302**. In this implementation the configuration data storage **132** can be alternatively used as the program storage **310** when the implantable device **100** is used as the SCU **302**. In this implementation, XMTR **168** corresponds to the signal transmitter **304** and the RCVR **114b** corresponds to the signal receiver **306** (contemplated to be operable using sound means via transducer **138**) and the RCVR **114a** and XMTR **146** correspond to the transceiver **314** (contemplated to be operable using magnetic means via coil **116**).

[0036] In a embodiment, the contents of the program storage **310**, i.e., the software that controls the operation of the programmable controller **308**, can be remotely downloaded, e.g., from the clinician's programmer **172** using data modulated onto an AC magnetic field. In this embodiment, it is contemplated that the contents of the program storage **310** for each SCU **302** be protected from an inadvertent change. Accordingly, the contents of the address storage circuitry **108**, i.e., the ID **303**, is used as a security code to confirm that the new program storage contents are destined for the SCU **302** receiving the data. This feature is significant if multiple patient's could be physically located, e.g., in adjoining beds, within the communication range of the clinician's programmer **172**.

[0037] In a further aspect of the present embodiment, it is preferable that the SCU **302** be operable for an extended period of time, e.g., in excess of one hour, from an internal power supply **316**. While a primary battery, i.e., a non-rechargeable battery, is suitable for this function, it is contemplated that the power supply **316** include a rechargeable battery, e.g., battery **104** as described in the U.S. Pat. No. 6,185,452, that can be recharged via an AC magnetic field produced external to the patient's body. Accordingly, the power supply **102** of FIG. 3A (described in detail in the U.S. Pat. No. 6,185,452) is the preferred power supply **316** for the SCU **302** as well.

[0038] The battery-powered devices 100 of the U.S. Pat. No. 6,185,452 are configurable to operate in a plurality of operation modes, e.g., via a communicated command signal. In a first operation mode, device 100 is remotely configured to be a microstimulator, e.g., 100a and 100b. In this embodiment, controller 130 commands stimulation circuitry 110 to generate a sequence of drive pulses through electrodes 112 to stimulate tissue, e.g., a nerve, proximate to the implanted location of the microstimulator, e.g., 100a or 100b. In operation, a programmable pulse generator 178 and voltage multiplier 180 are configured with parameters (see Table I) corresponding to a desired pulse sequence and specifying how much to multiply the battery voltage (e.g., by summing charged capacitors or similarly charged battery portions) to generate a desired compliance voltage V_c . A first FET 182 is periodically energized to store charge into capacitor 183 (in a first direction at a low current flow rate through the body tissue) and a second FET 184 is periodically energized to discharge capacitor 183 in an opposing direction at a higher current flow rate which stimulates a nearby nerve. Alternatively, electrodes can be selected that will form an equivalent capacitor within the body tissue.

TABLE I

Stimulation Parameters	
Current:	continuous current charging of storage capacitor
Charging currents:	1, 3, 10, 30, 100, 250, 500 μ a
Current Range:	0.8 to 40 ma in nominally 3.2% steps
Compliance Voltage:	selectable, 3-24 volts in 3 volt steps
Pulse Frequency (PPS):	1 to 5000 PPS in nominally 30% steps
Pulse Width:	5 to 2000 μ s in nominally 10% steps
Burst On Time (BON):	1 ms to 24 hours in nominally 20% steps
Burst Off Time (BOF):	1 ms to 24 hours in nominally 20% steps
Triggered Delay to BON:	either selected BOF or pulse width
Burst Repeat Interval:	1 ms to 24 hours in nominally 20% steps
Ramp On Time:	0.1 to 100 seconds (1, 2, 5, 10 steps)
Ramp Off Time:	0.1 to 100 seconds (1, 2, 5, 10 steps)

[0039] In a next operation mode, the battery-powered implantable device 100 can be configured to operate as a microsensor, e.g., 100c, that can sense one or more physiological or biological parameters in the implanted environment of the device. In accordance with a mode of operation, the system control unit 302 periodically requests the sensed data from each microsensor 100c using its ID stored in address storage 108, and responsively sends command signals to microstimulators, e.g., 100a and 100b, adjusted accordingly to the sensed data. For example, sensor circuitry 188 can be coupled to the electrodes 112 to sense or otherwise used to measure a biological parameter, e.g., temperature, glucose level, or O_2 content and provided the sensed data to the controller circuitry 106. The sensor circuitry may include a programmable bandpass filter and an analog to digital (A/D) converter that can sense and accordingly convert the voltage levels across the electrodes 112 into a digital quantity. Alternatively, the sensor circuitry can include one or more sense amplifiers to determine if the measured voltage exceeds a threshold voltage value or is within a specified voltage range. Furthermore, the sensor circuitry 188 can be configurable to include integration circuitry to further process the sensed voltage. The operation modes of the sensor circuitry 188 is remotely programmable via the devices communication interface as shown below in Table II.

TABLE II

Sensing Parameters	
Input voltage range:	5 μ v to 1 V
Bandpass filter rolloff:	24 dB
Low frequency cutoff choices:	3, 10, 30, 100, 300, 1000 Hz
High frequency cutoff choices:	3, 10, 30, 100, 300, 1000 Hz
Integrator frequency choices:	1 PPS to 100 PPS
Amplitude threshold for detection choices:	4 bits of resolution

[0040] Additionally, the sensing capabilities of a microsensor include the capability to monitor the battery status via path 124 from the charging circuit 122 and can additionally include using the ultrasonic transducer 138 or the coil 116 to respectively measure the magnetic or ultrasonic signal magnitudes (or transit durations) of signals transmitted between a pair of implanted devices and thus determine the relative locations of these devices. This information can be used to determine the amount of body movement, e.g., the amount that an elbow or finger is bent, and thus form a portion of a closed loop motion control system.

[0041] In another operation mode, the battery-powered implantable device 100 can be configured to operate as a microtransponder, e.g., 100d. In this operation mode, the microtransponder receives (via the aforementioned receiver means, e.g., AC magnetic, sonic, RF or electric) a first command signal from the SCU 302 and retransmits this signal (preferably after reformatting) to other implanted devices (e.g., microstimulators, microsensors, and/or microtransponders) using the aforementioned transmitter means (e.g., magnetic, sonic, RF or electric). While a microtransponder may receive one mode of command signal, e.g., magnetic, it may retransmit the signal in another mode, e.g., ultrasonic. For example, clinician's programmer 172 may emit a modulated magnetic signal using a magnetic emitter 190 to program/command the implanted devices 100. However, the magnitude of the emitted signal may not be sufficient to be successfully received by all of the implanted devices 100. As such, a microtransponder 100d may receive the modulated magnetic signal and retransmit it (preferably after reformatting) as a modulated ultrasonic signal which can pass through the body with fewer restrictions. In another exemplary use, the patient control unit 174 may need to monitor a microsensor 100c in a patient's foot. Despite the efficiency of ultrasonic communication in a patient's body, an ultrasonic signal could still be insufficient to pass from a patient's foot to a patient's wrist (the typical location of the patient control unit 174). As such, a microtransponder 100d could be implanted in the patient's torso to improve the communication link.

[0042] FIG. 4 shows the basic format of an exemplary message 192 for communicating with the aforementioned battery-powered devices 100, all of which are preconfigured with an address (ID), preferably unique to that device, in their identification storage 108 to operate in one or more of the following modes (1) for nerve stimulation, i.e., as a microstimulator, (2) for biological parameter monitoring, i.e., as a microsensor, and/or (3) for retransmitting received signals after reformatting to other implanted devices, i.e., as a microtransponder. The command message 192 is primarily comprised of a (1) start portion 194 (one or more bits to signify the start of the message and to synchronize the bit

timing between transmitters and receivers, (2) a mode portion **196** (designating the operating mode, e.g., microstimulator, microsensor, microtransponder, or group mode), (3) an address (ID) portion **198** (corresponding to either the identification address **108** or a programmed group ID), (4) a data field portion **200** (containing command data for the prescribed operation), (5) an error checking portion **202** (for ensuring the validity of the message **192**, e.g., by use of a parity bit), and (6) a stop portion **204** (for designating the end of the message **192**). The basic definition of these fields are shown below in Table II. Using these definitions, each device can be separately configured, controlled and/or sensed as part of a system for controlling one or more neural pathways within a patient's body.

TABLE III

Message Data Fields		
MODE		ADDRESS (ID)
00 =	Stimulator	8 bit identification address
01 =	Sensor	8 bit identification address
02 =	Transponder	4 bit identification address
03 =	Group	4 bit group identification address
Data Field Portion		
Program/Stimulate =	select operating mode	
Parameter/Preconfiguration	select programmable parameter in	
Select =	program mode or preconfigured	
	stimulation or sensing parameter in	
	other modes	
Parameter Value =	program value	

[0043] Additionally, each device **100** can be programmed with a group ID (e.g., a 4 bit value) which is stored in its configuration data storage **132**. When a device **100**, e.g., a microstimulator, receives a group ID message that matches its stored group ID, it responds as if the message was directed to its identification address **108**. Accordingly, a plurality of microstimulators, e.g., **100a** and **100b**, can be commanded with a single message. This mode is of particular use when precise timing is desired among the stimulation of a group of nerves.

[0044] The following describes exemplary commands, corresponding to the command message **192** of FIG. 4, which demonstrate some of the remote control/sensing capabilities of the system of devices which comprise the present invention:

[0045] Write Command—Set a microstimulator/microsensor specified in the address field **198** to the designated parameter value.

[0046] Group Write Command—Set the microstimulators/microsensors within the group specified in the address field **198** to the designated parameter value.

[0047] Stimulate Command—Enable a sequence of drive pulses from the microstimulator specified in the address field **198** according to previously programmed and/or default values.

[0048] Group Stimulate Command—Enable a sequence of drive pulses from the microstimulators within the group specified in the address field **198** according to previously programmed and/or default values.

[0049] Unit Off Command—Disable the output of the microstimulator specified in the address field **198**.

[0050] Group Stimulate Command—Disable the output of the microstimulators within the group specified in the address field **198**.

[0051] Read Command—Cause the microsensor designated in the address field **198** to read the previously programmed and/or default sensor value according to previously programmed and/or default values.

[0052] Read Battery Status Command—Cause the microsensor designated in the address field **198** to return its battery status.

[0053] Define Group Command—Cause the microstimulator/microsensor designated in the address field **198** to be assigned to the group defined in the microstimulator data field **200**.

[0054] Set Telemetry Mode Command—Configure the microtransponder designated in the address field **198** as to its input mode (e.g., AC magnetic, sonic, etc.), output mode (e.g., AC magnetic, sonic, etc.), message length, etc.

[0055] Status Reply Command—Return the requested status/sensor data to the requesting unit, e.g., the SCU.

[0056] Download Program Command—Download program/safe harbor routines to the device, e.g., SCU, microstimulator, etc., specified in the address field **198**.

[0057] FIG. 5 shows a block diagram of an exemplary open loop control program, i.e., a task scheduler **320**, for controlling/monitoring a body function/parameter. In this process, the programmable controller **308** is responsive to the clock **312** (preferably crystal controlled to thus permit real time scheduling) in determining when to perform any of a plurality of tasks. In this exemplary flow chart, the programmable controller **308** first determines in block **322** if is now at a time designated as T_{EVENT1} (or at least within a sampling error of that time), e.g., at 1:00 AM. If so, the programmable controller **308** transmits a designated command to microstimulator A (ST_A) in block **324**. In this example, the control program continues where commands are sent to a plurality of stimulators and concludes in block **326** where a designated command is sent to microstimulator X (ST_X). Such a subprocess, e.g., a subroutine, is typically used when multiple portions of body tissue require stimulation, e.g., stimulating a plurality of muscle groups in a paralyzed limb to avoid atrophy. The task scheduler **320** continues through multiple time event detection blocks until in block **328** it determines whether the time T_{EVENTM} has arrived. If so, the process continues at block **330** where, in this case, a single command is sent to microstimulator M (ST_M). Similarly, in block **332** the task scheduler **320** determines when it is the scheduled time, i.e., T_{EVENTO} , to execute a status request from microsensor A (SE_A). If so, a subprocess, e.g., a subroutine, commences at block **334** where a command is sent to microsensor A (SE_A) to request sensor data and/or specify sensing criteria. Microsensor A (SE_A) does not instantaneously respond. Accordingly, the programmable controller **308** waits for a response in block **336**. In block **338**, the returned sensor status data from microsensor A (SE_A) is stored in a portion of the memory, e.g., a volatile portion of the program storage **310**, of the programmable controller **308**. The task scheduler **320** can be a programmed sequence, i.e., defined in software stored in the program storage **310**, or, alternatively, a predefined function controlled by a table of parameters similarly stored in the program storage **310**. A similar process can be used where the SCU **302** periodically interrogates each implantable device **100** to determine its battery status.

[0058] FIG. 6 shows an exemplary use of an optional translation table 340 for communicating between the SCU 302 and microstimulators, e.g., 100a, and/or microsensors, e.g., 100c, via microtransponders, e.g., 100d. A microtransponder, e.g., 100d, is used when the communication range of the SCU 302 is insufficient to reliably communicate with other implanted devices 100. In this case, the SCU 302 instead directs a data message, i.e., a data packet, to an intermediary microtransponder, e.g., 100d, which retransmits the data packet to a destination device 100. In an exemplary implementation, the translation table 340 contains pairs of corresponding entries, i.e., first entries 342 corresponding to destination addresses and second entries 344 corresponding to the intermediary microtransponder addresses. When the SCU 302 determines, e.g., according to a timed event designated in the program storage 310, that a command is to be sent to a designated destination device (see block 346), the SCU 302 searches the first entries 342 of the translation table 340, for the destination device address, e.g., ST_M . The SCU 302 then fetches the corresponding second table entry 344 in block 348 and transmits the command to that address. When the second table entry 344 is identical to its corresponding first table entry 342, the SCU 302 transmits commands directly to the implanted device 100. However, when the second table entry 344, e.g., T_N , is different from the first table entry 342, e.g., ST_M , the SCU 302 transmits commands via an intermediary microtransponder, e.g., 100d. The use of the translation table 340 is optional since the intermediary addresses can, instead, be programmed directly into a control program contained in the program storage 310. However, it is preferable to use such a translation table 340 in that communications can be redirected on the fly by just reprogramming the translation table 340 to take advantage of implanted transponders as required, e.g., if communications should degrade and become unreliable. The translation table 340 is preferably contained in programmable memory, e.g., RAM or EPROM, and can be a portion of the program storage 310. While the translation table 340 can be remotely programmed, e.g., via a modulated signal from the clinician's programmer 172, it is also envisioned that the SCU 302 can reprogram the translation table 340 if the communications degrade.

[0059] FIG. 7 is an exemplary block diagram showing the use of the system of the present embodiment to perform closed loop control of a body function. In block 352, the SCU 302 requests status from microsensor A (SE_A). The SCU 302, in block 354, then determines whether a current command given to a microstimulator is satisfactory and, if necessary, determines a new command and transmits the new command to the microstimulator A in block 356. For example, if microsensor A (SE_A) is reading a voltage corresponding to a pressure generated by the stimulation of a muscle, the SCU 302 could transmit a command to microstimulator A (ST_A) to adjust the sequence of drive pulses, e.g., in magnitude, duty cycle, etc., and accordingly change the voltage sensed by microsensor A (SE_A). Accordingly, closed loop, i.e., feedback, control is accomplished. The characteristics of the feedback (position, integral, derivative (PID)) control are preferably program controlled by the SCU 302 according to the control program contained in program storage 310.

[0060] FIG. 8 shows an exemplary injury treatable by embodiments of the present system 300. In this exemplary injury, the neural pathway has been damaged, e.g., severed,

just above the patient's left elbow. The goal of this exemplary system is to bypass the damaged neural pathway to permit the patient to regain control of the left hand. An SCU 302 is implanted within the patient's torso to control plurality of stimulators, ST_1 - ST_5 , implanted proximate to the muscles respectively controlling the patient's thumb and fingers. Additionally, microsensor 1 (SE_1) is implanted proximate to an undamaged nerve portion where it can sense a signal generated from the patient's brain when the patient wants hand closure. Optional microsensor 2 (SE_2) is implanted in a portion of the patient's hand where it can sense a signal corresponding to stimulation/motion of the patient's pinky finger and microsensor 3 (SE_3) is implanted and configured to measure a signal corresponding to grip pressure generated when the fingers of the patient's hand are closed. Additionally, an optional microtransponder (T_1) is shown which can be used to improve the communication between the SCU 302 and the implanted devices.

[0061] FIG. 9 shows an exemplary flow chart for the operation of the SCU 302 in association with the implanted devices in the exemplary system of FIG. 8. In block 360, the SCU 302 interrogates microsensor 1 (SE_1) to determine if the patient is requesting actuation of his fingers. If not, a command is transmitted in block 362 to all of the stimulators (ST_1 - ST_5) to open the patient's hand, i.e., to de-energize the muscles which close the patient's fingers. If microsensor 1 (SE_1) senses a signal to actuate the patient's fingers, the SCU 302 determines in block 364 whether the stimulators ST_1 - ST_5 are currently energized, i.e., generating a sequence of drive pulses. If not, the SCU 302 executes instructions to energize the stimulators. In a first optional path 366, each of the stimulators are simultaneously (subject to formatting and transmission delays) commanded to energize in block 366a. However, the command signal given to each one specifies a different start delay time (using the BON parameter). Accordingly, there is a stagger between the actuation/closing of each finger.

[0062] In a second optional path 368, the microstimulators are consecutively energized by a delay Δ . Thus, microstimulator 1 (ST_1) is energized in block 368a, a delay is executed within the SCU 302 in block 368b, and so on for all of the microstimulators. Accordingly, paths 366 and 368 perform essentially the same function. However, in path 366 the interdevice timing is performed by the clocks within each implanted device 100 while in path 368, the SCU 302 is responsible for providing the interdevice timing.

[0063] In path 370, the SCU 302 actuates a first microstimulator (ST_1) in block 370a and waits in block 370b for its corresponding muscle to be actuated, as determined by microsensor 2 (SE_2), before actuating the remaining stimulators (ST_2 - ST_5) in block 370c. This implementation could provide more coordinated movement in some situations.

[0064] Once the stimulators have been energized, as determined in block 364, closed loop grip pressure control is performed in blocks 372a and 372b by periodically reading the status of microsensor 3 (SE_3) and adjusting the commands given to the stimulators (ST_1 - ST_5) accordingly. Consequently, this exemplary system has enabled the patient to regain control of his hand including coordinated motion and grip pressure control of the patient's fingers.

[0065] Referring again to FIG. 3A, a magnetic sensor 186 is shown. In the U.S. Pat. No. 6,185,452, it was shown that such a sensor 186 could be used to disable the operation of an implanted device 100, e.g., to stop the operation of such

devices in an emergency situation, in response to a DC magnetic field, preferably from an externally positioned safety magnet 187. A further implementation is disclosed herein. The magnetic sensor 186 can be implemented using various devices. Exemplary of such devices are devices manufactured by Nonvolatile Electronics, Inc. (e.g., their AA, AB, AC, AD, or AG series), Hall effect sensors, and subminiature reed switches. Such miniature devices are configurable to be placed within the housing of the disclosed SCU 302 and implantable devices 100. While essentially passive magnetic sensors, e.g., reed switches, are possible, the remaining devices include active circuitry that consumes power during detection of the DC magnetic field. Accordingly, it is contemplated that controller circuitry 302 periodically, e.g., once a second, provide power to the magnetic sensor 186 and sample the sensor's output signal 374 during that sampling period.

[0066] In a preferred implementation of the SCU 302, the programmable controller 308 is a microcontroller operating under software control wherein the software is located within the program storage 310. The SCU 302 preferably includes an input 376, e.g., a non maskable interrupt (NMI), which causes a safe harbor subroutine 378, preferably located within the program storage 310, to be executed. Additionally, failure or potential failure modes, e.g., low voltage or over temperature conditions, can be used to cause the safe harbor subroutine 378 to be executed. Typically, such a subroutine could cause a sequence of commands to be transmitted to set each microstimulator into a safe condition for the particular patient configuration, typically disabling each microstimulator. Alternatively, the safe harbor condition could be to set certain stimulators to generate a prescribed sequence of drive pulses. Preferably, the safe harbor subroutine 378 can be downloaded from an external device, e.g., the clinician's programmer 172, into the program storage 310, a nonvolatile storage device. Additionally, it is preferable that, should the programmable contents of the program storage be lost, e.g., from a power failure, a default safe harbor subroutine be used instead. This default subroutine is preferably stored in nonvolatile storage that is not user programmable, e.g., ROM, that is otherwise a portion of the program storage 310. This default subroutine is preferably general purpose and typically is limited to commands that turn off all potential stimulators.

[0067] Alternatively, such programmable safe harbor subroutines 378 can exist in the implanted stimulators 100. Accordingly, a safe harbor subroutine could be individually programmed into each microstimulator that is customized for the environments of that microstimulator and a safe harbor subroutine for the SCU 302 could then be designated that disables the SCU 302, i.e., causes the SCU 302 to not issue subsequent commands to other implanted devices 100.

[0068] FIGS. 10A and 10B show two side cutaway views of the presently preferred construction of the sealed housing 206, the battery 104 and the circuitry (implemented on one or more IC chips 216 to implement electronic portions of the SCU 302) contained within. In this presently preferred construction, the housing 206 is comprised of an insulating ceramic tube 260 brazed onto a first end cap forming electrode 112a via a braze 262. At the other end of the ceramic tube 260 is a metal ring 264 that is also brazed onto the ceramic tube 260. The circuitry within, i.e., a capacitor 183 (used when in a microstimulator mode), battery 104, IC chips 216, and a spring 266 is attached to an opposing

second end cap forming electrode 112b. A drop of conductive epoxy is used to glue the capacitor 183 to the end cap 112a and is held in position by spring 266 as the glue takes hold. Preferably, the IC chips 216 are mounted on a circuit board 268 over which half circular longitudinal ferrite plates 270 are attached. The coil 116 is wrapped around the ferrite plates 270 and attached to IC chips 216. A getter 272, mounted surrounding the spring 266, is preferably used to increase the hermeticity of the SCU 302 by absorbing water introduced therein. An exemplary getter 272 absorbs 70 times its volume in water. While holding the circuitry and the end cap 112b together, one can laser weld the end cap 112b to the ring 264. Additionally, a platinum, iridium, or platinum-iridium disk or plate 274 is preferably welded to the end caps of the SCU 302 to minimize the impedance of the connection to the body tissue.

[0069] Referring to FIG. 10B, the present embodiment provides a temperature sensor circuitry generally known to those skilled in the art that comprises an integrated circuit semiconductor temperature sensor which is functionally based on temperature characteristics of bipolar and/or field effect transistors. The contemplated temperature sensor circuitry is provided on the IC chip 216 and can measure temperatures in a range of about 15 to about 95 degrees centigrade with a more optimal sensitivity in the preferred range of about 33 to about 45 degrees centigrade. It is known that temperature sensitivity is a function of a transistor's defining equations and is predictable over typical semiconductor/transistor operating ranges. A temperature sensor may use a diode-connected bipolar transistor through which a small amount of constant current is passed. A constant current through the base-emitter junction produces a junction voltage between the base and emitter that is a linear function of the absolute temperature. The current is chosen to be small enough to avoid self-heating. Additional diode-connected bipolar transistors may be included in the temperature sensor circuitry to minimize the effects of non-ideal circuit behavior such as variability in source current. Gain circuitry may be also provided in order to further increase the sensitivity of the temperature sensor. It is also known to those skilled in the art that discrete components such as thermistors, varistors or other temperature-sensitive components may be utilized in the present embodiment to sense a desired temperature.

[0070] An exemplary battery 104 is described more fully below in connection with the description of FIG. 11. Preferably, the battery 104 is made from appropriate materials so as to provide a power capacity of at least 1 microwatt-hour, preferably constructed from a battery having an energy density of about 240 mW-Hr/cm³. A Li-I battery advantageously provides such an energy density. Alternatively, an Li-I-Sn battery provides an energy density up to 360 mW-Hr/cm³. Any of these batteries, or other batteries providing a power capacity of at least 1 microwatt-hour may be used with implanted devices of the present embodiment.

[0071] The battery voltage V of an exemplary battery is nominally 3.6 volts, which is more than adequate for operating the CMOS circuits preferably used to implement the IC chip(s) 216, and/or other electronic circuitry, within the SCU 302. The battery voltage V, in general, is preferably not allowed to discharge below about 2.55 volts, or permanent damage may result. Similarly, the battery 104 should preferably not be charged to a level above about 4.2 volts, or else permanent damage may result. Hence, a charging circuit 122

(discussed in the U.S. Pat. No. 6,185,452) is used to avoid any potentially damaging discharge or overcharge.

[0072] The battery 104 may take many forms, any of which may be used so long as the battery can be made to fit within the small volume available. As previously discussed, the battery 104 may be either a primary battery or a rechargeable battery. A primary battery offers the advantage of a longer life for a given energy output but presents the disadvantage of not being rechargeable (which means once its energy has been used up, the implanted device no longer functions). However, for many applications, such as one-time-only muscle rehabilitation regimens applied to damaged or weakened muscle tissue, the SCU 302 and/or devices 100 need only be used for a short time (after which they can be explanted and discarded, or simply left implanted as benign medical devices). For other applications, a rechargeable battery is clearly the preferred type of energy choice, as the tissue stimulation provided by the microstimulator is of a recurring nature.

[0073] The considerations relating to using a rechargeable battery as the battery 104 of the implantable device 100 are presented, inter alia, in the book, *Rechargeable Batteries, Applications Handbook*, EDN Series for Design Engineers, Technical Marketing Staff of Gates Energy Products, Inc. (Butterworth-Heinemann 1992). The basic considerations for any rechargeable battery relate to high energy density and long cycle life. Lithium based batteries, while historically used primarily as a nonrechargeable battery, have in recent years appeared commercially as rechargeable batteries. Lithium-based batteries typically offer an energy density of from 240 mW-Hr/cm³ to 360 mW-Hr/cm³. In general, the higher the energy density the better, but any battery construction exhibiting an energy density resulting in a power capacity greater than 1 microwatt-hour is suitable for the present invention.

[0074] One of the more difficult hurdles facing the use of a battery 104 within the SCU 302 relates to the relatively small size or volume inside the housing 206 within which the battery must be inserted. A typical SCU 302 made in accordance with the present invention is no larger than about 60 mm long and 8 mm in diameter, preferably no larger than 60 mm long and 6 mm in diameter, and includes even smaller embodiments, e.g., 15 mm long with an O.D. of 2.2 mm (resulting in an I.D. of about 2 mm). When one considers that only about ¼ to ½ of the available volume within the device housing 206 is available for the battery, one begins to appreciate more fully how little volume, and thus how little battery storage capacity, is available for the SCU 302.

[0075] FIG. 11 shows an exemplary battery 104 typical of those disclosed in the great grandparent application. Specifically, a parallel-connected cylindrical electrode embodiment is shown where each cylindrical electrode includes a gap or slit 242; with the cylindrical electrodes 222 and 224 on each side of the gap 242 forming a common connection point for tabs 244 and 246 which serve as the electrical terminals for the battery. The electrodes 222 and 224 are separated by a suitable separator 248. The gap 242 minimizes the flow of eddy currents in the electrodes. For this embodiment, there are four concentric cylindrical electrodes 222, the outer one (largest diameter) of which may function as the battery case 234, and three concentric electrodes 224 interleaved between the electrodes 222, with six concentric

cylindrical separator layers 248 separating each electrode 222 or 224 from the adjacent electrodes.

[0076] The temperature sensor circuitry of the present embodiment is incorporated in the sensor 188 shown in FIG. 3A and is contained in the chip 216 of the FIG. 10B. The sensor 188 as part of the implantable device provides a sensed temperature value, such as the temperature of the body of a patient, in a form of status signals to the controller 134, wherein this information can be transmitted via either transmitter 168 or 146 to the SCU 302. As described in reference to FIG. 2, the receiver 306 in SCU 302, receives the status signals from an implantable device, an wherein the programmable controller 308 in the SCU 302 produces notification signals based on the received status signals. It is contemplated that the SCU 302 communicates with a notification unit which may be in a form of the patient control unit 174, the clinician's programmer 172 or a display unit. The notification unit communicating with the SCU 302 receives the notification signals for disclosing/displaying the sensed body temperature based on the notification signals. It is further contemplated that in an aspect of the present embodiment, at least one implantable device generates communication signals, namely status signals, based on the sensed body temperature and communicates the same directly to the notification unit, wherein the sensed body temperature is disclosed/displayed. The notification unit can be in the form of an audible alarm system, a display unit or a graphic display. In another aspect of the present embodiment, it is contemplated that a plurality of implantable devices are placed in different positions within a body and communicate with the SCU 302. The SCU 302 is adapted to determine a temperature difference between the different positions based on the status signals received from each implantable device. It should be noted that in the above embodiments and aspects of the present invention, the communication between the implantable device(s) and the SCU and/or the notification unit may be unidirectional i.e., from the implantable device(s) to the SCU and/or notification unit. In the alternative, the communication may be bidirectional such that the SCU and/or notification unit can transmit command signals to the implantable device(s) for performing functions such as stimulation, sensing, or directing the implantable device(s) to transmit sensed temperature information (status signals) according to a predetermined or desired duty cycle. In utilizing a duty cycle format, there will be conservation on the power consumption of the implantable device(s) resulting in longer battery life.

[0077] Accordingly, an embodiment of the present invention is comprised of an implanted SCU 302 and a plurality of implanted devices 100, each of which contains its own rechargeable battery 104. As such, a patient is essentially independent of any external apparatus between battery chargings (which generally occur no more often than once an hour). However, for some treatment regimen, it may be adequate to use a power supply analogous to that described in U.S. Pat. No. 5,324,316 that only provides power while an external AC magnetic field is being provided, e.g., from charger 118. Additionally, it may be desired, e.g., from a cost standpoint, to implement the SCU 302 as an external device, e.g., within a watch-shaped housing that can be attached to a patient's wrist in a similar manner to the patient control unit 174.

[0078] The power consumption of the SCU 302 is primarily dependent upon the circuitry implementation, preferably

CMOS, the circuitry complexity and the clock speed. For a simple system, a CMOS implemented state machine will be sufficient to provide the required capabilities of the programmable controller **308**. However, for more complex systems, e.g., a system where an SCU **302** controls a large number of implanted devices **100** in a closed loop manner, a microcontroller may be required. As the complexity of such microcontrollers increases (along with its transistor count), so does its power consumption. Accordingly, a larger battery having a capacity of 1 watt-hour is preferred. While a primary battery is possible, it is preferable that a rechargeable battery be used. Such larger batteries will require a larger volume and accordingly, cannot be placed in the injectable housing described above. However, a surgically implantable device within a larger sealed housing, e.g., having at least one dimension in excess of 1 inch, will serve this purpose when used in place of the previously discussed injectable housing **206**. FIG. 12 shows an exemplary implantable housing **380** suitable for such a device.

[0079] While the invention herein disclosed has been described by means of specific embodiments and applications thereof, numerous modifications and variations could be made thereto by those skilled in the art without departing from the scope of the invention set forth in the claims. For example, a system including multiple SCUs, e.g., one external and one internal, is considered to be within the scope of the present invention. Additionally, while the use of a single communication channel for communication between one or more SCUs and the other implanted devices has been described, a system implemented using multiple communication channels, e.g., a first sonic channel at a first carrier frequency and a second sonic channel at a second carrier frequency, is also considered to be within the scope of the present invention.

[0080] What is claimed is:

1. A system for monitoring temperature in a body, the system comprising:

at least one implantable device comprising a sealed elongate housing configured for implantation in a body, said sealed housing having an axial dimension of less than 60 mm and a lateral dimension of less than 6 mm, wherein said at least one implantable device is operable to sense temperature in the body and to generate status signals based on the sensed temperature in the body; and

a system control unit for wirelessly communicating with the at least one implantable device, said system control unit comprising:

a housing;

a signal receiver in said housing for receiving the status signals; and

a programmable controller in said housing for producing notification signals based on the received status signals; a notification unit communicating with the system control unit for disclosing the sensed body temperature based on the notification signals.

2. The system of claim 1, wherein the body is a living body.

3. The system of claim 1, wherein the system control unit further comprises:

a signal transmitter in said housing for transmitting command signals, wherein said system control unit controls controllable operating parameters in said at least one implantable device.

4. The system of claim 3, wherein the system control unit commands the at least one implantable device to generate the status signals based on the sensed temperature in the body.

5. The system of claim 4, wherein the notification unit is an audible alarm system.

6. The system of claim 4, wherein the notification unit is a display unit.

7. The system of claim 6, wherein the display unit is a graphic display.

8. The system of claim 4, wherein the system control unit is suitable for implantation in the body.

9. The system of claim 1, wherein a first implantable device is placed in a first position and a second implantable device is placed in a second position, and wherein the system control unit is adapted to determine a temperature difference between the first position and the second position based on the status signals received from the first implantable device and the second implantable device.

10. A system for monitoring temperature in a body, the system comprising:

at least one implantable device comprising a sealed elongate housing configured for implantation in a body, said sealed housing having an axial dimension of less than 60 mm and a lateral dimension of less than 6 mm, wherein said at least one implantable device is operable to sense temperature in the body and to generate communication signals responsive to the sensed body temperature; and

a notification unit, communicating with the at least one implantable device, for disclosing the sensed body temperature.

* * * * *

专利名称(译)	监测温度的系统		
公开(公告)号	US20080092911A1	公开(公告)日	2008-04-24
申请号	US10/920570	申请日	2004-08-18
[标]申请(专利权)人(译)	SCHULMAN JOSEPH ^ h 胃食道逆流约翰·C· WOLFE JAMES ^ h		
申请(专利权)人(译)	SCHULMAN JOSEPH ^ h 胃食道逆流约翰·C· WOLFE JAMES ^ h		
[标]发明人	SCHULMAN JOSEPH H GORD JOHN C WOLFE JAMES H		
发明人	SCHULMAN, JOSEPH H. GORD, JOHN C. WOLFE, JAMES H.		
IPC分类号	A61B19/00 A61B5/00 A61B5/053 A61B5/07 A61B5/103 A61F2/50 A61F2/70 A61F2/72 A61N1/372 A61N1/378		
CPC分类号	A61B5/0008 A61N1/3787 A61B5/0031 A61B5/053 A61B5/07 A61B5/076 A61B5/1071 A61B5/145 A61B5/14532 A61B5/1473 A61B2560/0209 A61B2560/0219 A61B2562/08 A61F2/72 A61F2002/5058 A61F2002/704 A61F2002/705 A61N1/37205 A61N1/37288 A61B5/0028		
优先权	60/042447 1997-03-27 US 60/039164 1997-02-26 US 60/497392 2003-08-22 US		
其他公开文献	US8555894		
外部链接	Espacenet USPTO		

摘要(译)

一种用于监测体内温度的系统，该系统包括至少一个可植入装置，其中可植入装置可操作以感测体内温度并基于体内感测到的温度产生状态信号。该系统还包括用于与可植入设备无线通信的系统控制单元，以及包括用于接收状态信号的信号接收器的系统控制单元，以及用于基于接收的状态信号产生通知信号的可编程控制器。通知单元可替代地与系统控制单元或可植入设备通信，以基于通知信号公开所感测的体温。

