



US 20070260129A1

(19) **United States**

(12) **Patent Application Publication**
Chin

(10) **Pub. No.: US 2007/0260129 A1**

(43) **Pub. Date: Nov. 8, 2007**

(54) **MEDICAL SENSOR AND TECHNIQUE FOR USING THE SAME**

Publication Classification

(51) **Int. Cl.**
A61B 5/00 (2006.01)

(76) **Inventor: Rodney P. Chin, Carson City, NV (US)**

(52) **U.S. Cl.** **600/323; 600/344**

Correspondence Address:
Nellcor Puritan Bennett LLC
c/o Fletcher Yoder PC
P.O. BOX 692289
HOUSTON, TX 77269-2289 (US)

(57) **ABSTRACT**

A medical sensor may be adapted to be affixed to a patient's skin. A sensor for pulse oximetry or other spectrophotometric uses is provided with a gripping region that contacts the patient's skin and provides gripping strength to reduce movement of the sensor. Also provided herein is a method of contacting a sensor to a patient's skin and method of manufacturing a sensor.

(21) **Appl. No.: 11/415,642**

(22) **Filed: May 2, 2006**

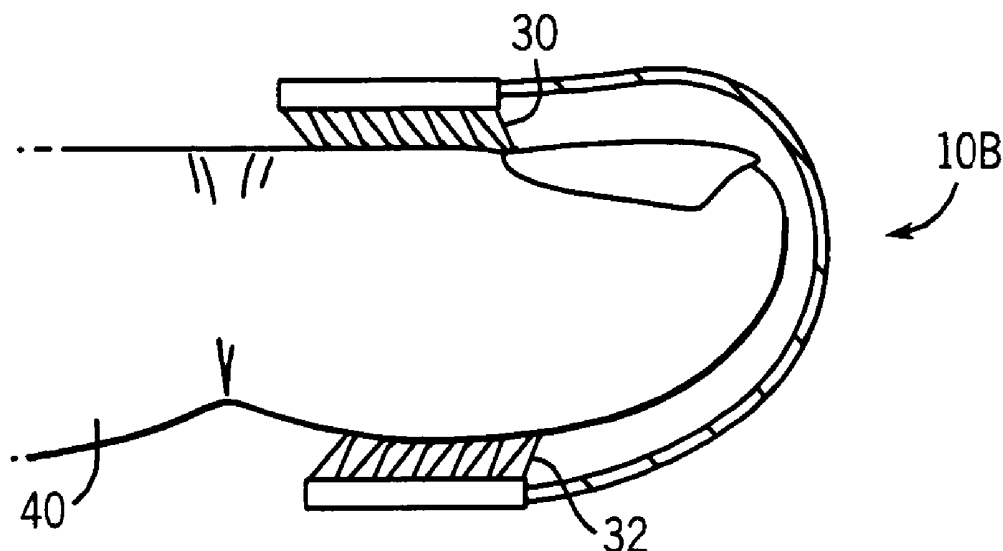

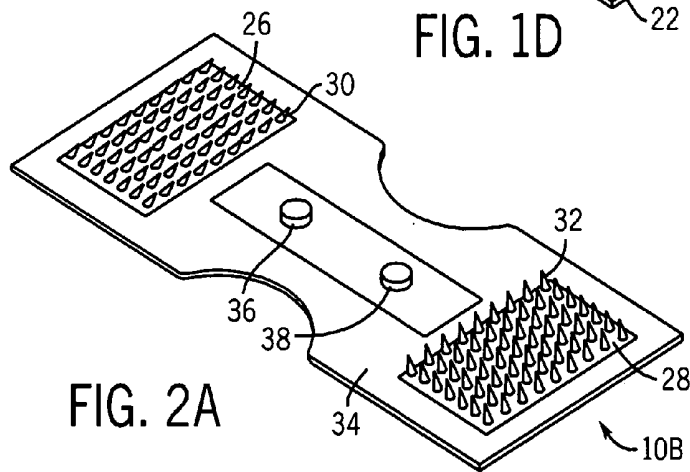
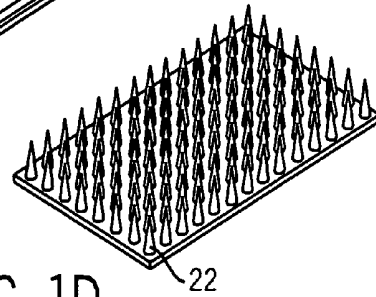
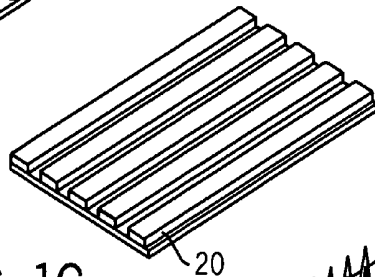
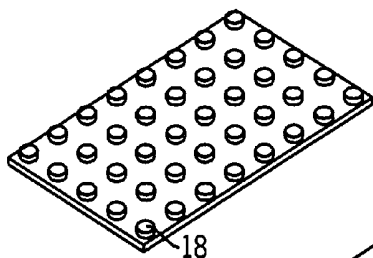
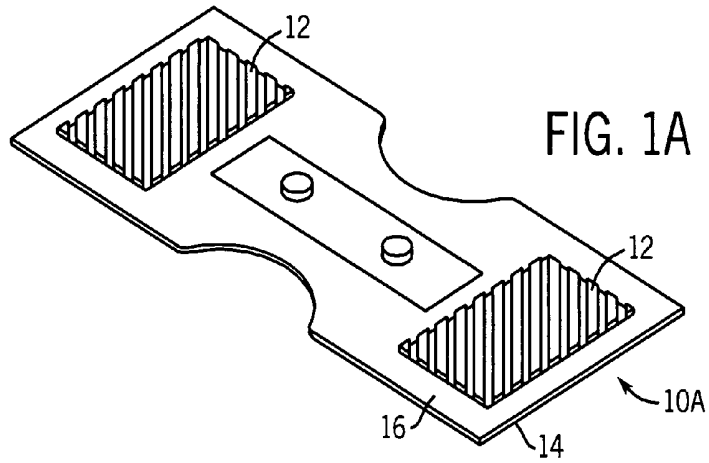

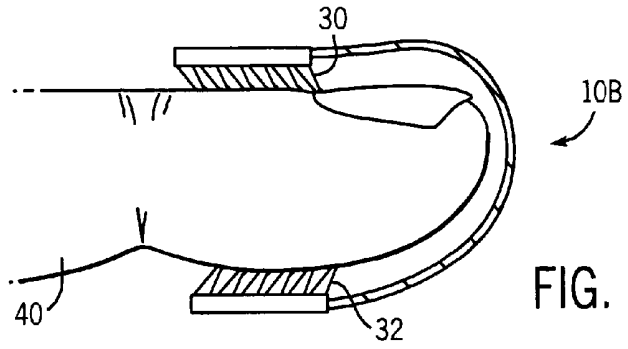

FIG. 2B

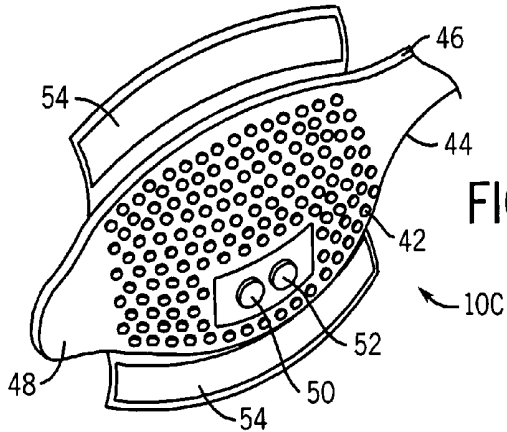

FIG. 3

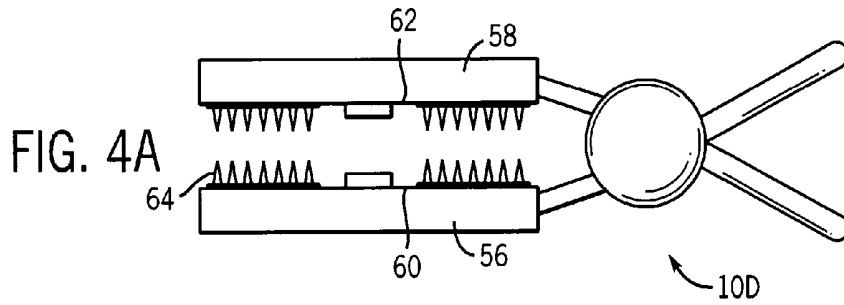

FIG. 4A

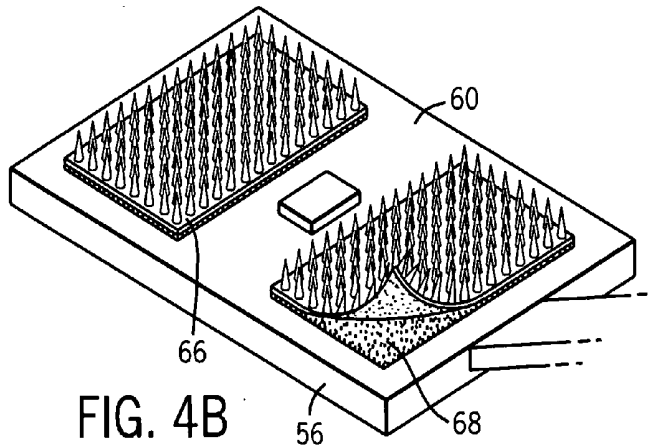

FIG. 4B

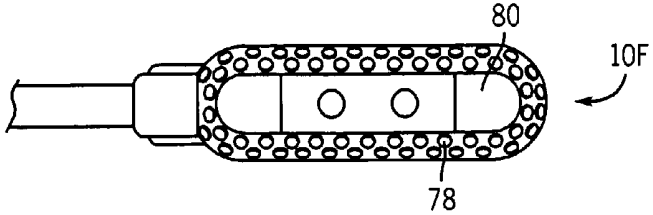
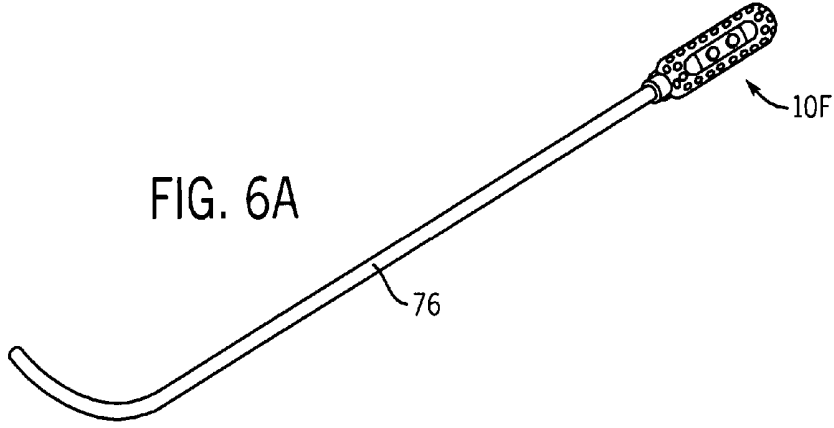
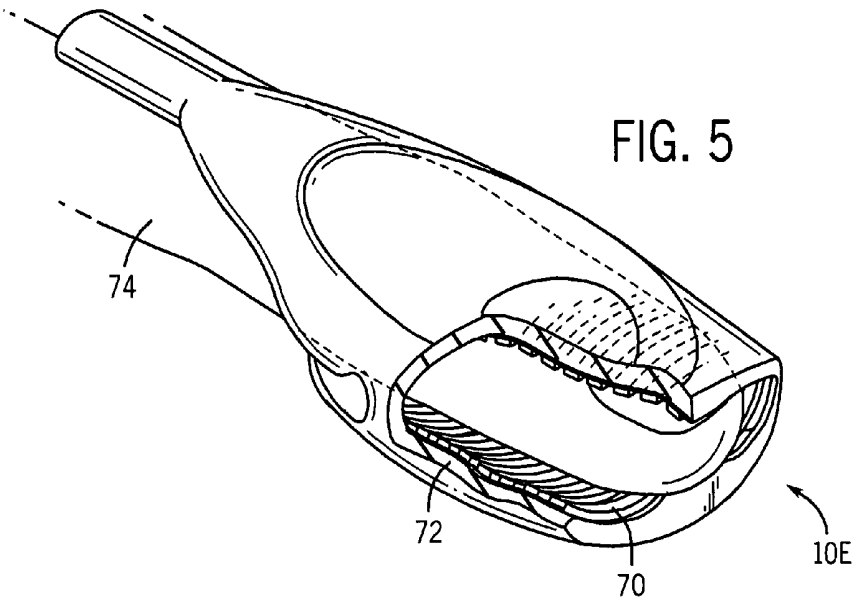

FIG. 6B

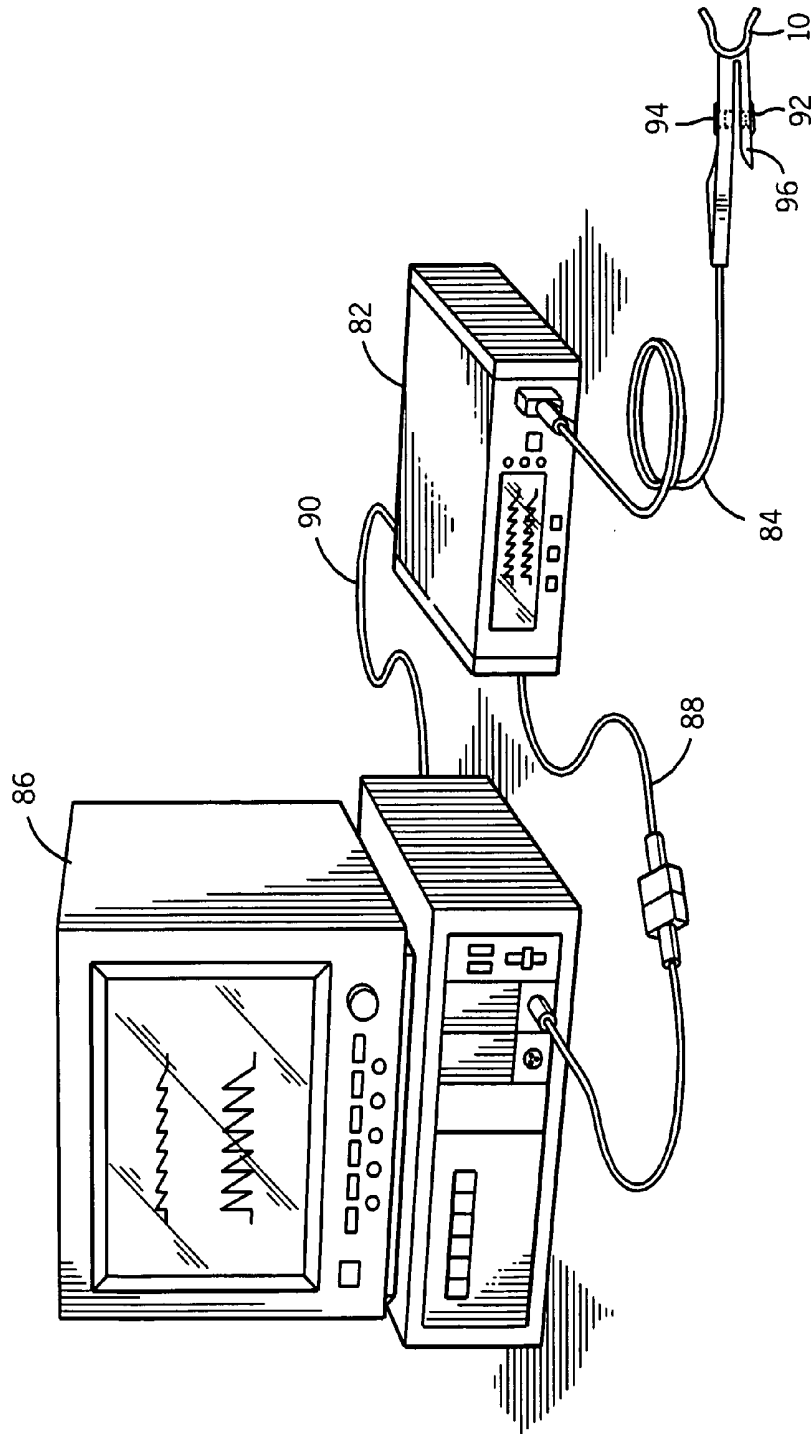

FIG. 7

MEDICAL SENSOR AND TECHNIQUE FOR USING THE SAME

BACKGROUND OF THE INVENTION

[0001] 1. Field Of The Invention

[0002] The present invention relates generally to medical devices and, more particularly, to sensors used for sensing physiological parameters of a patient.

[0003] 2. Description Of The Related Art

[0004] This section is intended to introduce the reader to various aspects of art that may be related to various aspects of the present invention which are described and/or claimed below. This discussion is believed to be helpful in providing the reader with background information to facilitate a better understanding of the various aspects of the present invention. Accordingly, it should be understood that these statements are to be read in this light, and not as admissions of prior art.

[0005] In the field of medicine, doctors often desire to monitor certain physiological characteristics of their patients. Accordingly, a wide variety of devices have been developed for monitoring many such physiological characteristics. Such devices provide doctors and other healthcare personnel with the information they need to provide the best possible healthcare for their patients. As a result, such monitoring devices have become an indispensable part of modern medicine.

[0006] One technique for monitoring certain physiological characteristics of a patient is commonly referred to as pulse oximetry, and the devices built based upon pulse oximetry techniques are commonly referred to as pulse oximeters. Pulse oximetry may be used to measure various blood flow characteristics, such as the blood-oxygen saturation of hemoglobin in arterial blood, the volume of individual blood pulsations supplying the tissue, and/or the rate of blood pulsations corresponding to each heartbeat of a patient. In fact, the "pulse" in pulse oximetry refers to the time varying amount of arterial blood in the tissue during each cardiac cycle.

[0007] Pulse oximeters typically utilize a non-invasive sensor that transmits light through a patient's tissue and that photoelectrically detects the absorption and/or scattering of the transmitted light in such tissue. One or more of the above physiological characteristics may then be calculated based upon the amount of light absorbed or scattered. More specifically, the light passed through the tissue is typically selected to be of one or more wavelengths that may be absorbed or scattered by the blood in an amount correlative to the amount of the blood constituent present in the blood. The amount of light absorbed and/or scattered may then be used to estimate the amount of blood constituent in the tissue using various algorithms.

[0008] Accurate pulse oximetry measurements depend on the secure placement of a sensor on the desired measurement site on a patient's skin. Pulse oximetry sensors are typically either disposable bandage-type structures that attach the sensor components to the patient with adhesive materials, or reusable clip-type devices that affix the sensor components in place with tension provided by a spring. Regardless of the type of sensor used, the sensor should fit snugly enough that

incidental patient motion will not dislodge the sensor, yet not so tight that normal blood flow is disrupted, which may interfere with pulse oximetry measurements. Furthermore, lack of a secure fit may allow ambient light to reach the photodetecting elements of the sensor, thus introducing error into the pulse oximetry measurements. Additionally, sensor movement may lead to motion artifacts, another potential source of measurement error.

[0009] Pulse oximetry sensors are used in emergency room and trauma center settings where the sensor may be exposed to liquids and/or bodily fluids. A patient's sweat or blood, for example, may interfere with the ability of adhesive bandages to adhere to the skin. Further, reusable sensors are subject to frequent repositioning, which may lead to weakening of the mechanical components of a clip-style sensor. Thus, an improved securing mechanism may be desirable.

SUMMARY

[0010] Certain aspects commensurate in scope with the originally claimed invention are set forth below. It should be understood that these aspects are presented merely to provide the reader with a brief summary of certain forms that the invention might take and that these aspects are not intended to limit the scope of the invention. Indeed, the invention may encompass a variety of aspects that may not be set forth below.

[0011] There is provided a sensor that includes: a sensor body; at least one sensing element disposed on the sensor body; and a non-adhesive gripping portion having raised protrusions disposed on a tissue-contacting surface of the sensor body.

[0012] There is also provided a pulse oximetry system that includes a pulse oximetry monitor and a pulse oximetry sensor adapted to be operatively coupled to the monitor. The sensor includes a sensor body; at least one sensing element disposed on the sensor body; and a non-adhesive gripping portion having raised protrusions disposed on a tissue-contacting surface of the sensor body.

[0013] There is also provided a method of operating a sensor that includes: contacting a patient's skin with a non-adhesive gripping portion having raised protrusions of a sensor body; emitting light from an emitter disposed on the sensor body; and detecting the light with a detector disposed on the sensor body.

[0014] There is also provided a method of manufacturing a sensor that includes: providing a sensor body, wherein a non-adhesive gripping portion having raised protrusions is disposed on a tissue-contacting surface of the sensor body; and providing at least one sensing element disposed on the sensor body.

BRIEF DESCRIPTION OF THE DRAWINGS

[0015] Advantages of the invention may become apparent upon reading the following detailed description and upon reference to the drawings in which:

[0016] FIG. 1 A illustrates a perspective view of an embodiment of an exemplary bandage-type pulse oximetry sensor with non-adhesive gripping regions according to the present invention;

[0017] FIGS. 1B-D illustrate alternate embodiments of non-adhesive gripping portions;

[0018] FIG. 2A illustrates an embodiment of an exemplary bandage-type pulse oximetry sensor with directional non-adhesive gripping regions according to the present invention;

[0019] FIG. 2B illustrates a cross-sectional view of the pulse oximetry sensor of FIG. 3A applied to a patient's finger;

[0020] FIG. 3 illustrates a perspective side view of an embodiment of an exemplary forehead pulse oximetry sensor according to the present invention;

[0021] FIG. 4A illustrates a cross-sectional view of an embodiment of an exemplary clip-style pulse oximetry sensor according to the present invention;

[0022] FIG. 4B illustrates a perspective view of the clip-style pulse oximetry sensor of FIG. 4A in which the non-adhesive gripping portion is removable;

[0023] FIG. 5 illustrates an embodiment of an exemplary molded pulse oximetry sensor with an integral non-adhesive gripping portion according to the present invention;

[0024] FIG. 6A illustrates a perspective view of an embodiment of a fetal pulse oximetry sensor with a non-adhesive gripping portion according to the present invention;

[0025] FIG. 6B illustrates an enlarged view of the sensor of FIG. 6A; and

[0026] FIG. 7 illustrates a pulse oximetry system coupled to a multi-parameter patient monitor and a sensor according to embodiments of the present invention.

DETAILED DESCRIPTION OF SPECIFIC EMBODIMENTS

[0027] One or more specific embodiments of the present invention will be described below. In an effort to provide a concise description of these embodiments, not all features of an actual implementation are described in the specification. It should be appreciated that in the development of any such actual implementation, as in any engineering or design project, numerous implementation-specific decisions must be made to achieve the developers' specific goals, such as compliance with system-related and business-related constraints, which may vary from one implementation to another. Moreover, it should be appreciated that such a development effort might be complex and time consuming, but would nevertheless be a routine undertaking of design, fabrication, and manufacture for those of ordinary skill having the benefit of this disclosure.

[0028] In accordance with the present techniques, the exemplary medical sensors described below may be used for pulse oximetry or other spectrophotometric uses. The techniques described below reduce sensor movement by providing a durable, non-adhesive gripping contact with a patient's skin.

[0029] Pulse oximetry sensors are typically placed on a patient in a location that is normally perfused with arterial blood to facilitate measurement of the desired blood characteristics, such as arterial oxygen saturation measurement

(SpO₂). Common sensor placement sites include a patient's fingertips, toes, forehead, or earlobes. Regardless of the location of the sensor, it is often desirable to provide a secure attachment of the sensor to a patient's skin.

[0030] Several factors may affect the ability of the sensor to firmly attach to the sensor site. Sensors are generally worn for several hours before being removed or repositioned. Thus, a patient may sweat or bleed in the area of the tissue covered by the sensor, creating a slick surface that promotes sliding of the sensor relative to the skin. Additionally, when a sensor is repositioned every few hours, as typically recommended, each application weakens the adhesiveness of any adhesive bandages, as well as the spring force of any mechanical components of the sensor.

[0031] Sensors as described herein may include an emitter and a detector that may be of any suitable type. For example, the emitter may be one or more light emitting diodes adapted to transmit one or more wavelengths of light in the red to infrared range, and the detector may be a photodetector selected to receive light in the range or ranges emitted from the emitter. For pulse oximetry applications using either transmission or reflectance type sensors the oxygen saturation of the patient's arterial blood may be determined using two or more wavelengths of light, most commonly red and near infrared wavelengths. Similarly, in other applications, a tissue water fraction (or other body fluid related metric) or a concentration of one or more biochemical components in an aqueous environment may be measured using two or more wavelengths of light, most commonly near infrared wavelengths between about 1,000 nm to about 2,500 nm. It should be understood that, as used herein, the term "light" may refer to one or more of infrared, visible, ultraviolet, or even X-ray electromagnetic radiation, and may also include any wavelength within the infrared, visible, ultraviolet, or X-ray spectra.

[0032] The sensors disclosed herein include a non-adhesive gripping portion to provide a securing mechanism and to reduce sensor movement after application of the sensor to the patient. The non-adhesive gripping portions described below in relation to the exemplary embodiments may be constructed from any suitable material that functions to provide additional gripping strength between the sensor 10 and the patient's tissue. For example, a suitable non-adhesive gripping portion may be made of plastic, rubber, silicone, vinyl, or woven material. For example, the non-adhesive gripping portion may be a relatively thin, flexible material such as Super Grip® Easy Liner® (Henkel) that is disposed on the tissue-contacting surface of the sensor 10. As described below in certain embodiments, the non-adhesive gripping portion may be integrally constructed with the sensor 10, for example molded onto the tissue-contacting surface. In other embodiments, the non-adhesive gripping portion may be a separate component. As described below, it may be advantageous to apply a removable non-adhesive gripping portion to a reusable sensor, so that the non-adhesive gripping portion may be detached and replaced multiple times.

[0033] In certain embodiments, a non-adhesive gripping portion comprises a material that has a relatively large static coefficient of friction. A material with a large static coefficient of friction helps to keep sensor stable relative to the skin as a patient moves. According to the present techniques,

the static coefficient of friction of a material may be tested using the following procedure: (1) Attach a protractor to a vertical wall with the center in line with the edge of a table. (2) Set up a stop block at the edge of the table to act as a pivot point for a glass plate. (3) Place the glass plate flat on the table with one edge along the edge of the table, up against the stop block. (4) Place a test sample of the material on the glass plate. (5) Lift the free edge of the glass plate until the test sample just starts to slip. (6) Record angle at which slippage first occurred. This angle is the angle of repose. Then calculate the coefficient of friction, which is the tangent of the angle of repose.

[0034] The static coefficient of friction for a non-adhesive gripping portion may be greater than 10. In certain embodiments, the static coefficient of friction for a non-adhesive gripping portion may be greater than 100. A non-adhesive gripping portion may be a material that has a high static coefficient of friction relative to glass, such as polyvinyl chloride (PVC) foam.

[0035] One with skill in the art realizes that a static coefficient of friction calculated as described above is relative to a glass plate, and that other materials may be used as a reference point. For example, it may be desirable to calculate a static coefficient of friction of a material relative to a patient's skin. In certain embodiments, the non-adhesive gripping portion has a static coefficient of friction greater than 5 with respect to a patient's skin.

[0036] FIG. 1A illustrates an exemplary transmission-type bandage sensor appropriate for use on a patient's digit. As shown in FIG. 1A, a sensor 10A may have non-adhesive gripping portions 12 that are disposed on a conformable sensor body 14 on a tissue-contacting surface 16. The non-adhesive gripping portions 12 may have a texture. The texture may be visible to the unaided eye, or alternatively it may be a microtexture that is not visible to the unaided eye. The non-adhesive gripping portions 12 are characterized by a surface that provides frictional resistance when in contact with the patient's skin. In other embodiments, as shown in FIGS. 1B-D, the non-adhesive gripping portions 12 may contain raised protrusions, such as nubs 18 (FIG. 1B), ridges 20 (FIG. 1C) or barbs 22 (FIG. 1D).

[0037] The raised protrusions may be conformable or semi-rigid. For example, the barbs 22 may be conformable to avoid causing discomfort for the patient. Generally, it is envisioned that the raised protrusions may protrude at least about 0.1 mm from the surface of the sensor body. The raised protrusions may be rubber, silicone, or plastic. In certain embodiments, the raised protrusions may be formed from any suitable material with a durometer hardness ranging from 20-90 Shore D.

[0038] In situations in which a patient is ambulatory and is being continuously monitored, it may be desirable to affix a sensor 10 to the patient with sufficient gripping strength to prevent dislodgement resulting from everyday activity. FIG. 2A illustrates a bandage-type sensor 10B in which the conformable sensor body 24 contains directional non-adhesive portions 26 and 28 with angled barbs 30 and 32. The directional non-adhesive portions 26 and 28 are disposed on the tissue-contacting surface 34 of the conformable sensor body 26 such that the angled barbs 30 and 32 are oriented toward the emitter 36 and detector 38. As shown in FIG. 2B, when the sensor 10B is applied to a patient's digit 40, the

angled barbs 30 and 32 are oriented such that the sensor 10B is resistant to being pulled off the digit 40. Thus, the sensor 10B remains relatively secure if a patient wishes to be able to use his or her hands to type on a keyboard, for example.

[0039] It may be desirable to limit the use of adhesive materials on skin that is particularly fragile, such as that of a newborn infant. FIG. 3 illustrates an alternate embodiment in which a forehead sensor 10C has nubs 42 disposed on a tissue-contacting surface 44 of a sensor body 46. The sensor 10C has a finger-lift portion 48 that does not contain the nubs to allow for ease of sensor 10C removal. The nubs 42 protrude sufficiently to allow the sensor 10C to grip the forehead, but are not so elevated as to interfere with close contact of the emitter 50 and detector 52 with the skin. The sensor 10C has adhesive bandages 54 disposed around the perimeter of the sensor body 46. Such a configuration minimizes the use of adhesive bandages 54 while retaining adequate gripping to allow normal use of the sensor 10C. Because the area of skin surface contacted by adhesive is smaller as compared to a conventional sensor, there is a reduced risk of skin damage caused by the adhesive bandages 54. As depicted, the region containing the raised nubs 42 is at least 50% of the tissue-contacting surface 44 of the sensor 10C.

[0040] In other embodiments, the percentage of a tissue-contacting surface 44 of a sensor containing a non-adhesive gripping portion may vary depending on the activity level of the patient wearing the sensor, and the amount of adhesive bandages 54 used. In certain embodiments, it is contemplated that the surface area of a sensor that contains raised protrusions is inversely proportional to the amount of adhesive used. That is, if a sensor has raised protrusions on over half of its surface area, fewer adhesive bandages may be used in order to achieve a desirable level of frictional resistance to sensor movement. In certain embodiments, a non-adhesive gripping portion may be at least about 10%, and typically in a range from about 10% to about 95% of the tissue-contacting area of the sensor.

[0041] However, it should be understood that a very small surface area containing raised protrusions, such as nubs 42, may be effective at providing almost adhesive levels of gripping to the skin if placed on the sensor in areas that are prone to movement. For example, it may be desirable to design a finger sensor with a non-adhesive gripping portion in areas of a finger that are likely to move, such as joints.

[0042] Although the previously discussed embodiments have described conformable bandage-type sensors, it is also envisioned that similar advantages may be realized with relatively rigid cliptype sensors. For example, FIG. 4A shows a clip-type sensor 10D adapted to be applied to a patient's earlobe. The sensor 10D has portions 56 and 58 having tissue-contacting surfaces 60 and 62, on which raised barbs 64 are disposed. The barbs 64 grip the skin of the earlobe and resist movement of the sensor due to patient movement or gravity. As clip-type sensors are generally reusable, they are cleaned in between uses. Thus, it may be advantageous to be able to remove the barbs 64 for disposal, as their complex surfaces may trap dirt and sweat, thus making them difficult to clean. It is envisioned that the barbs 64 may be disposed on the tissue-contacting surfaces 60 and 62 on a backing 66 that is attached to the sensor body with a snap or other mechanism. In other embodiments, it may be

appropriate to use a hook and loop fastener 68, as shown in FIG. 4B. Thus, the barbs 64 may be easily peeled off and replaced by a healthcare worker.

[0043] In some instances, for cost and/or convenience, it may be desirable to manufacture sensors from a single mold. FIG. 5 illustrates an alternate embodiment in which a flexible molded slip-on type sensor 10E has integrally constructed molded ridges 70 disposed on a tissue-contacting surface 72. The sensor 10E is held on a patient's digit 74 by a combination of tension provided by the geometry and material of the sensor 10E and the gripping strength provided by ridges 70. The ridges 70 provide a mechanism for resisting movement of the sensor 10E relative to the digit 74. The ridges 70 are depicted as being orthogonally oriented to the digit 74 when the sensor 10E is applied to the patient. Thus, the frictional force of the ridges 70 opposes sliding of the digit 74 out of the sensor 10E. The ridges 70 may follow the contour of the digit 74, rising or falling in height to accommodate joints or finger pads. Since the ridges 70 are formed by molding, changes in the design of the sensor mold could easily accommodate a variety of arrangements of the ridges 70. For example, a wider spacing between ridges 70 may allow for ease in cleaning the sensor 10E between applications.

[0044] Sensors designed in accordance with the present techniques may provide advantages in liquid environments such as the uterus, in which the use of adhesives is not possible. In many instances, physicians wish to employ an intrauterine sensor to monitor physiological characteristics of a fetus, particularly during childbirth. An exemplary sensor 10F for intrauterine use is depicted in FIG. 6A. The sensor 10F is adapted to include a non-adhesive gripping portion 78 to assist the user in gripping the fetus' skin. The sensor 10F is normally manually introduced into the uterus and positioned against the fetus' head with a long, flexible handle 76 to allow proper placement of the sensor 10F. Fetal sensors, once properly positioned, may be held in place by a healthcare worker or by the pressure of the sensor 10F against the uterine walls for the checking of fetal blood oxygen. In other embodiments (not shown), the sensor 10F may be temporarily attached to the fetus' head with screws or other mechanisms. As illustrated in an enlarged view of the sensor body in FIG. 6B, the intrauterine fetal sensor 10F has a nonadhesive gripping portion 78 disposed around the perimeter of the tissue-contacting surface 80. The non-adhesive gripping portion 78 reduces movement of the sensor relative to the fetus' head, which may reduce motion artifacts.

[0045] Sensors designed in accordance with the present techniques, such as the exemplary sensors described above, illustrated generically as a sensor 10, may be used in conjunction with a pulse oximetry monitor 82, as illustrated in FIG. 7. It should be appreciated that the cable 84 of the sensor 10 may be coupled to the monitor 82 or it may be coupled to a transmission device (not shown) to facilitate wireless transmission between the sensor 10 and the monitor 82. The monitor 82 may be any suitable pulse oximeter, such as those available from Nellcor Puritan Bennett Inc. Furthermore, to upgrade conventional pulse oximetry provided by the monitor 82 to provide additional functions, the

monitor 82 may be coupled to a multi-parameter patient monitor 86 via a cable 88 connected to a sensor input port or via a cable 90 connected to a digital communication port.

[0046] The emitter 92 and the detector 94 may be disposed on a sensor body 96, which may be made of any suitable material, such as plastic, rubber, silicone, foam, woven material, or paper. Alternatively, the emitter 92 and the detector 94 may be remotely located and optically coupled to the sensor 10 using optical fibers. In the depicted embodiments, the sensor 10 is coupled to a cable 84 that is responsible for transmitting electrical and/or optical signals to and from the emitter 92 and detector 94 of the sensor 10. The cable 84 may be permanently coupled to the sensor 10, or it may be removably coupled to the sensor 10—the latter alternative being more useful and cost efficient in situations where the sensor 10 is disposable.

[0047] The sensor 10 may be a "transmission type" sensor. Transmission type sensors include an emitter 92 and detector 94 that are typically placed on opposing sides of the sensor site. If the sensor site is a fingertip, for example, the sensor 10 is positioned over the patient's fingertip such that the emitter 92 and detector 94 lie on either side of the patient's nail bed. In other words, the sensor 10 is positioned so that the emitter 92 is located on the patient's fingernail and the detector 94 is located 180° opposite the emitter 92 on the patient's finger pad. During operation, the emitter 92 shines one or more wavelengths of light through the patient's fingertip and the light received by the detector 94 is processed to determine various physiological characteristics of the patient. In each of the embodiments discussed herein, it should be understood that the locations of the emitter 92 and the detector 94 may be exchanged. For example, the detector 94 may be located at the top of the finger and the emitter 92 may be located underneath the finger. In either arrangement, the sensor 10 will perform in substantially the same manner.

[0048] Reflectance type sensors generally operate under the same general principles as transmittance type sensors. However, reflectance type sensors include an emitter 92 and detector 94 that are typically placed on the same side of the sensor site. For example, a reflectance type sensor may be placed on a patient's fingertip or forehead such that the emitter 92 and detector 94 lie side-by-side. Reflectance type sensors detect light photons that are scattered back to the detector 94.

[0049] While the invention may be susceptible to various modifications and alternative forms, specific embodiments have been shown by way of example in the drawings and have been described in detail herein. However, it should be understood that the invention is not intended to be limited to the particular forms disclosed. Indeed, the present techniques may not only be applied to measurements of blood oxygen saturation, but these techniques may also be utilized for the measurement and/or analysis of other blood constituents using principles of pulse oximetry. For example, using the same, different, or additional wavelengths, the present techniques may be utilized for the measurement and/or analysis of carboxyhemoglobin, met-hemoglobin, total hemoglobin, intravascular dyes, and/or water content. Rather, the invention is to cover all modifications, equivalents, and alternatives falling within the spirit and scope of the invention as defined by the following appended claims.

What is claimed is:

1. A sensor comprising:
 - a sensor body;
 - at least one sensing element disposed on the sensor body;
 - and
 - a non-adhesive gripping portion having raised protrusions disposed on a tissue-contacting surface of the sensor body.
2. The sensor, as set forth in claim 1, wherein the sensor comprises at least one of a pulse oximetry sensor or a sensor for measuring a water fraction.
3. The sensor, as set forth in claim 1, wherein the at least one sensing element comprises an emitter and a detector.
4. The sensor, as set forth in claim 3, wherein the emitter comprises at least one light emitting diode, and wherein the detector comprises at least one photodetector.
5. The sensor, as set forth in claim 1, wherein the non-adhesive gripping portion comprises plastic, rubber, silicone, or vinyl.
6. The sensor, as set forth in claim 1, wherein the non-adhesive gripping portion is disposed on at least 50% of the tissue-contacting surface of the sensor body.
7. The sensor, as set forth in claim 1, wherein the raised protrusions comprise barbs, nubs, or ridges.
8. The sensor, as set forth in claim 1, wherein the non-adhesive gripping portion is directional.
9. The sensor, as set forth in claim 1, wherein the non-adhesive gripping portion is disposed on greater than 10% of the tissue-contacting surface of the sensor body.
10. The sensor, as set forth in claim 1, wherein the sensor body is conformable.
11. The sensor, as set forth in claim 1, wherein the sensor comprises an adhesive disposed on the tissue-contacting surface of the sensor body.
12. The sensor, as set forth in claim 1, wherein the sensor comprises a clip-style sensor.
13. The sensor, as set forth in claim 1, wherein the sensor is adapted for intrauterine use.
14. A pulse oximetry system comprising:
 - a pulse oximetry monitor; and
 - a pulse oximetry sensor adapted to be operatively coupled to the monitor, the sensor comprising:
 - a sensor body;
 - at least one sensing element disposed on the sensor body; and
 - a non-adhesive gripping portion having raised protrusions disposed on a tissue-contacting surface of the sensor body.
15. The pulse oximetry system, as set forth in claim 14, wherein the sensor comprises a sensor for measuring a water fraction.
16. The pulse oximetry system, as set forth in claim 14, wherein the at least one sensing element comprises an emitter and a detector.
17. The pulse oximetry system, as set forth in claim 16, wherein the emitter comprises at least one light emitting diode, and wherein the detector comprises at least one photodetector.
18. The pulse oximetry system, as set forth in claim 14, wherein the non-adhesive gripping portion comprises plastic, rubber, silicone, or vinyl.
19. The pulse oximetry system, as set forth in claim 14, wherein the non-adhesive gripping portion is disposed on at least 50% of the tissue-contacting surface of the sensor body.
20. The pulse oximetry system, as set forth in claim 14, wherein the raised protrusions comprise barbs, nubs, or ridges.
21. The pulse oximetry system, as set forth in claim 14, wherein the non-adhesive gripping portion is directional.
22. The pulse oximetry system, as set forth in claim 14, wherein the non-adhesive gripping portion is disposed on greater than 10% of the tissue-contacting surface of the sensor body.
23. The pulse oximetry system, as set forth in claim 14, wherein the sensor body is conformable.
24. The pulse oximetry system, as set forth in claim 14, wherein the sensor comprises an adhesive disposed on the tissue-contacting surface of the sensor body.
25. The pulse oximetry system, as set forth in claim 14, wherein the sensor comprises a clip-style sensor.
26. The pulse oximetry system, as set forth in claim 14, wherein the sensor is adapted for intrauterine use.
27. A method comprising:
 - contacting a patient's skin with a non-adhesive gripping portion of a sensor body, the gripping portion having raised protrusions;
 - emitting light from an emitter disposed on the sensor body; and
 - detecting the light with a detector disposed on the sensor body.
28. The method, as set forth in claim 27, wherein contacting comprises contacting the patient's skin with a plastic, rubber, silicone, or vinyl non-adhesive gripping portion.
29. The method, as set forth in claim 27, wherein contacting comprises contacting the patient's skin with barbs, nubs, or ridges.
30. The method, as set forth in claim 27, wherein contacting comprises contacting the patient's skin with a directional non-adhesive gripping portion.
31. The method, as set forth in claim 27, wherein contacting comprises contacting the patient's skin with an adhesive disposed on the tissue-contacting surface of the sensor body.
32. A method of manufacturing a sensor, comprising:
 - providing a sensor body, wherein a non-adhesive gripping portion comprising raised protrusions is disposed on a tissue-contacting surface of the sensor body; and
 - providing at least one sensing element disposed on the sensor body.
33. The method, as set forth in claim 32, wherein providing at least one sensing element comprises providing an emitter and a detector.
34. The method, as set forth in claim 32, comprising:
 - providing barbs, nubs, or ridges on the non-adhesive gripping portion.
35. The method, as set forth in claim 32, wherein the non-adhesive gripping portion comprises plastic, rubber, silicone, or vinyl.

36. The method, as set forth in claim 32, wherein the non-adhesive gripping portion is directional.

37. The method, as set forth in claim 32, comprising:
providing the non-adhesive gripping portion on greater than 10% of the tissue-contacting surface of the sensor body.

38. The method, as set forth in claim 32, comprising:
providing the non-adhesive gripping portion on greater than 50% of the tissue-contacting surface of the sensor body.

39. The method, as set forth in claim 32, wherein the sensor body is conformable.

40. The method, as set forth in claim 32, comprising:
providing an adhesive disposed on the tissue-contacting surface of the sensor body.

41. The method, as set forth in claim 32, wherein the sensor comprises a clip-style sensor.

42. The method, as set forth in claim 32, wherein the sensor is adapted for intrauterine use.

* * * * *

专利名称(译)	医疗传感器及其使用技术		
公开(公告)号	US20070260129A1	公开(公告)日	2007-11-08
申请号	US11/415642	申请日	2006-05-02
[标]申请(专利权)人(译)	CHIN RODNEY P		
申请(专利权)人(译)	CHIN RODNEY P		
当前申请(专利权)人(译)	COVIDIEN LP		
[标]发明人	CHIN RODNEY P		
发明人	CHIN, RODNEY P.		
IPC分类号	A61B5/00		
CPC分类号	A61B5/02411 A61B5/02416 A61B5/02438 A61B5/14552 A61B5/1464 A61B2562/164 A61B5/6816 A61B5/6826 A61B5/6833 A61B5/6838 A61B5/4362		
其他公开文献	US7477924		
外部链接	Espacenet	USPTO	

摘要(译)

医疗传感器可以适于固定到患者的皮肤上。用于脉搏血氧测定法或其他分光光度计用途的传感器设置有抓握区域，该抓握区域接触患者的皮肤并提供抓握强度以减少传感器的移动。本文还提供了一种使传感器接触患者皮肤的方法和制造传感器的方法。

