



US 20070073123A1

(19) **United States**

(12) **Patent Application Publication**  
**Raridan, JR.**

(10) **Pub. No.: US 2007/0073123 A1**

(43) **Pub. Date: Mar. 29, 2007**

(54) **MEDICAL SENSOR AND TECHNIQUE FOR USING THE SAME**

**Publication Classification**

(76) Inventor: **William B. Raridan JR.**, Pleasanton, CA (US)

(51) **Int. Cl.**  
*A61B 5/00* (2006.01)  
(52) **U.S. Cl.** ..... **600/323**

Correspondence Address:  
**FLETCHER YODER (TYCO INTERNATIONAL, LTD.)**  
**P.O. BOX 692289**  
**HOUSTON, TX 77269-2289 (US)**

(57) **ABSTRACT**

A medical sensor may be adapted to account for factors that cause irregularities in pulse oximetry measurements or other spectrophotometric measurements. Sensors are provided with surface features that reduce the amount of outside light or shunted light that impinge the detecting elements of the sensor. The sensor is adapted to reduce the effect of outside light or shunted light on pulse oximetry measurements.

(21) Appl. No.: **11/241,508**

(22) Filed: **Sep. 29, 2005**

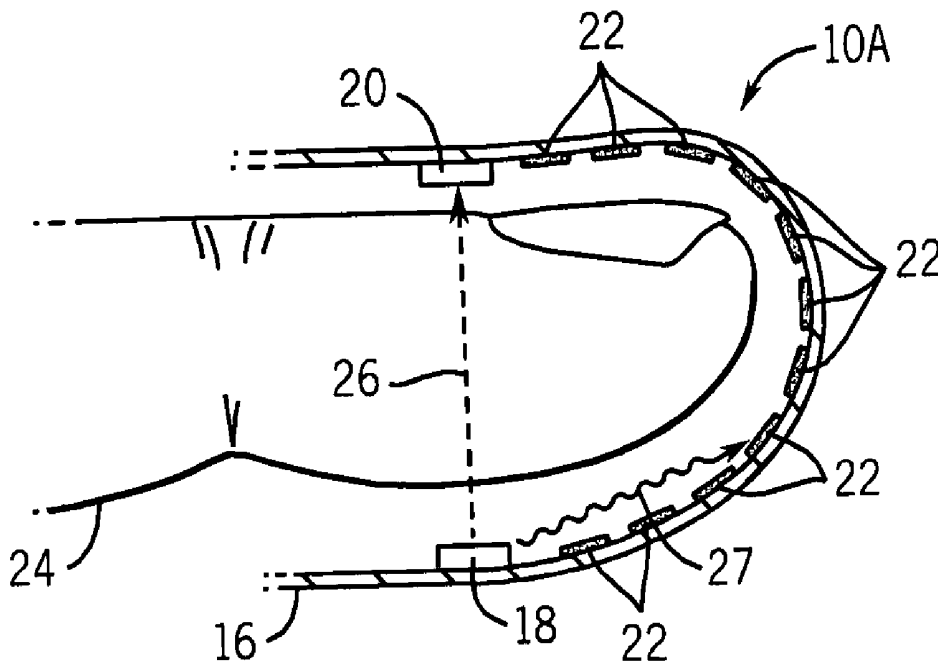

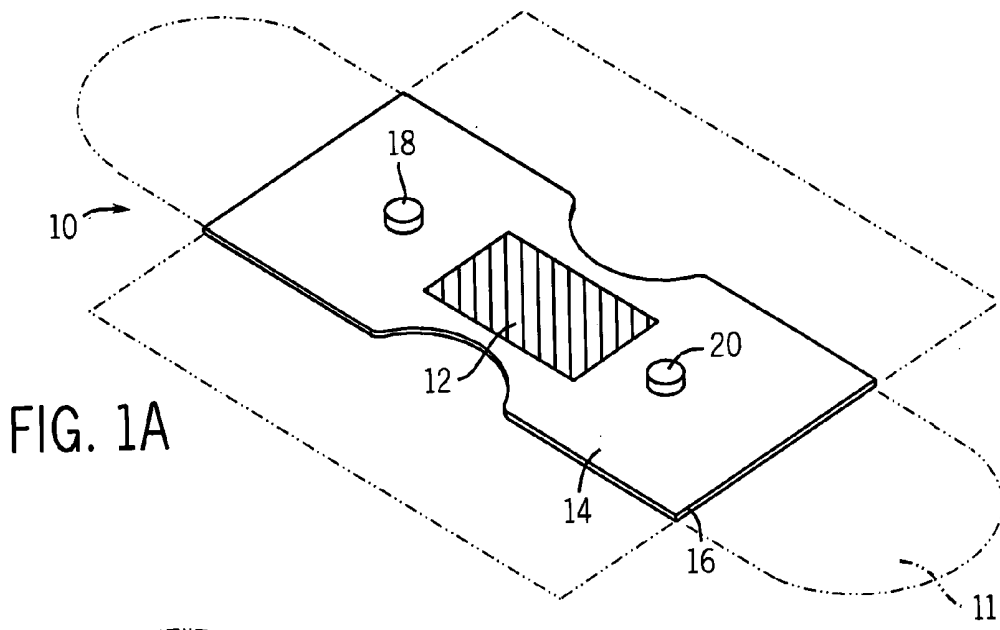

FIG. 1A

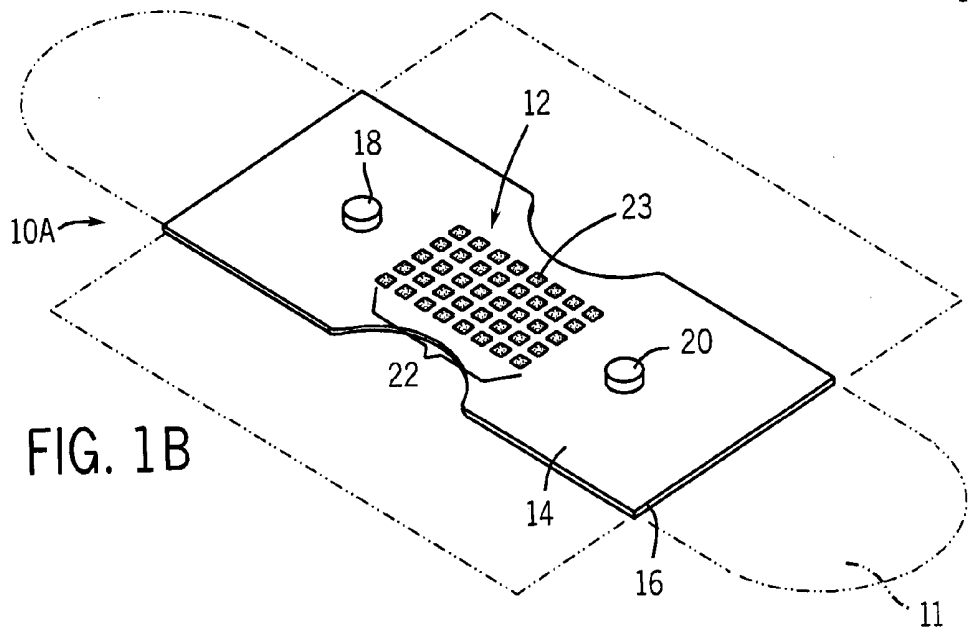

FIG. 1B

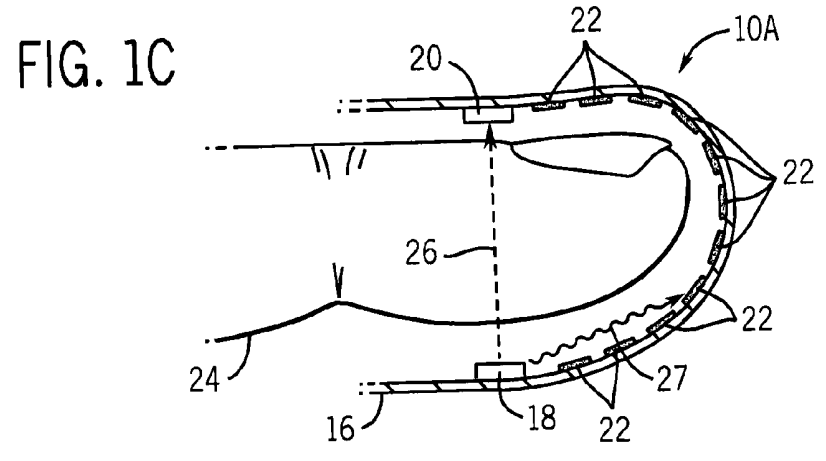

FIG. 1C

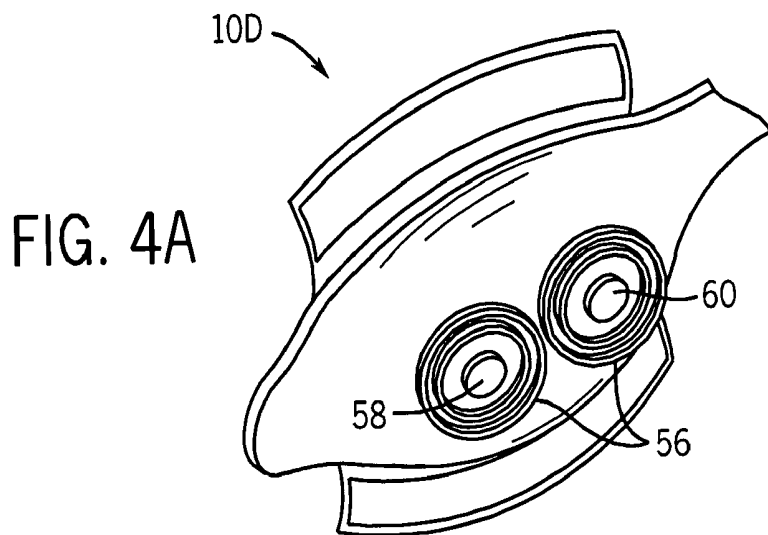
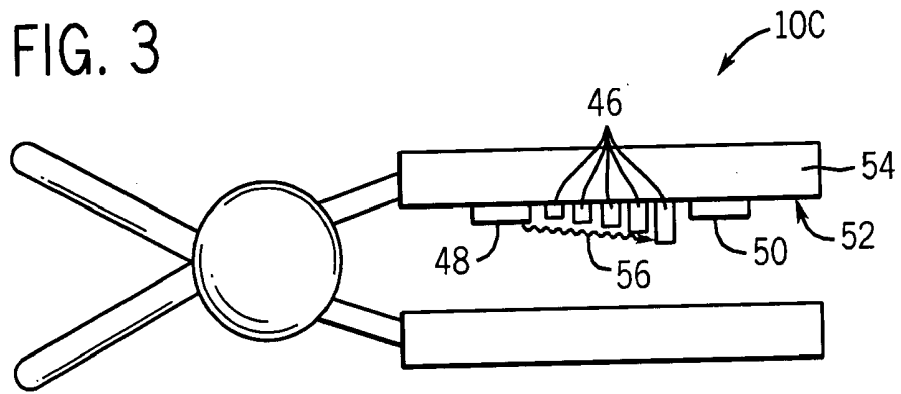
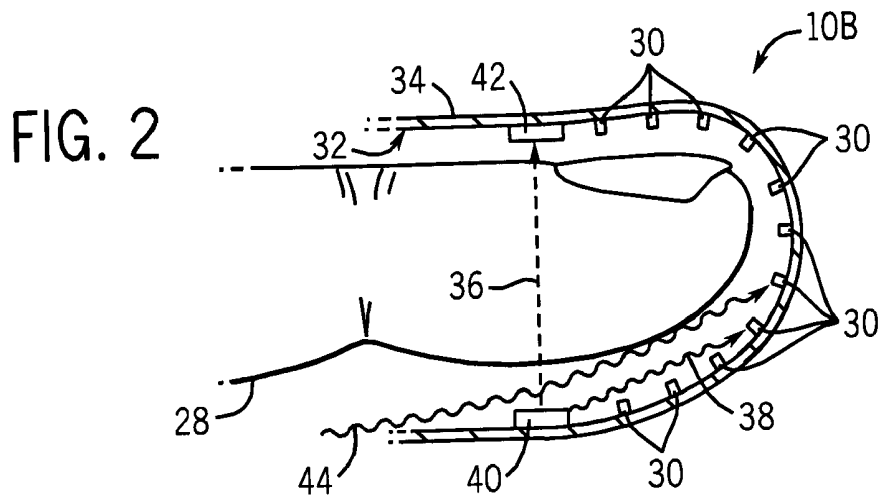

FIG. 4B

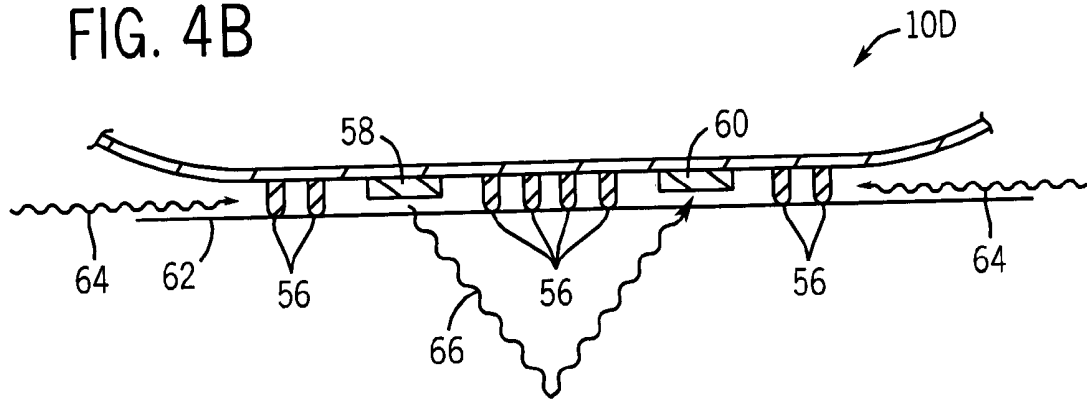

FIG. 5A

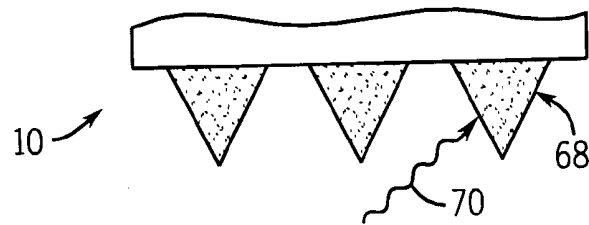

FIG. 5B

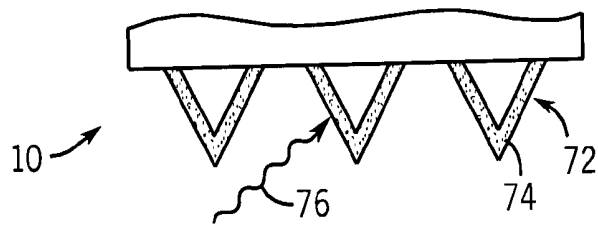

FIG. 5C

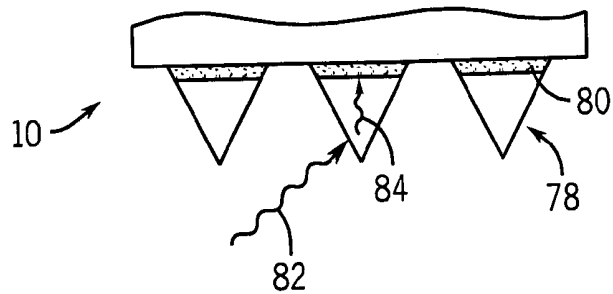

FIG. 5D

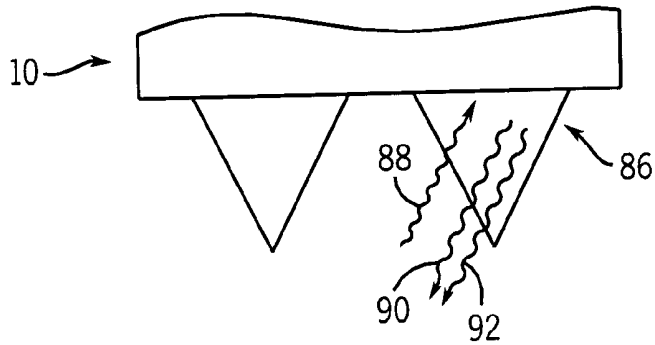

FIG. 6

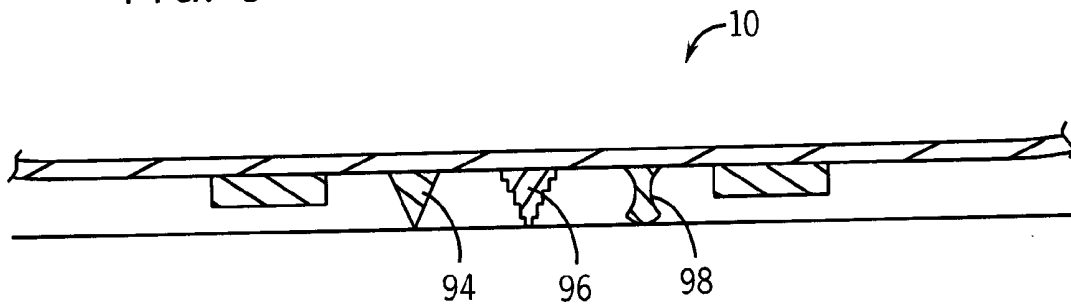
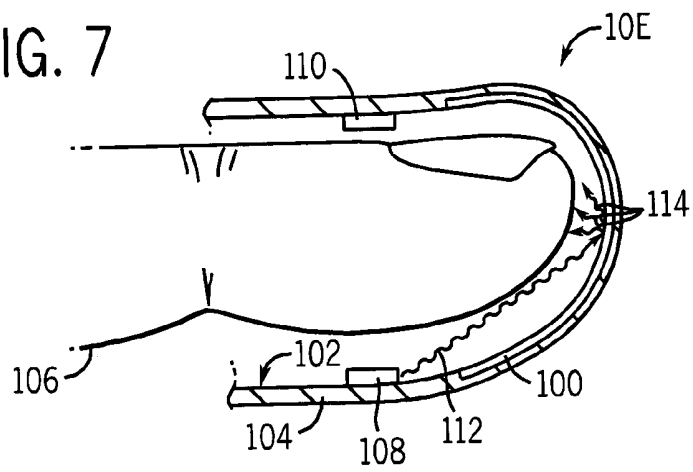

FIG. 7



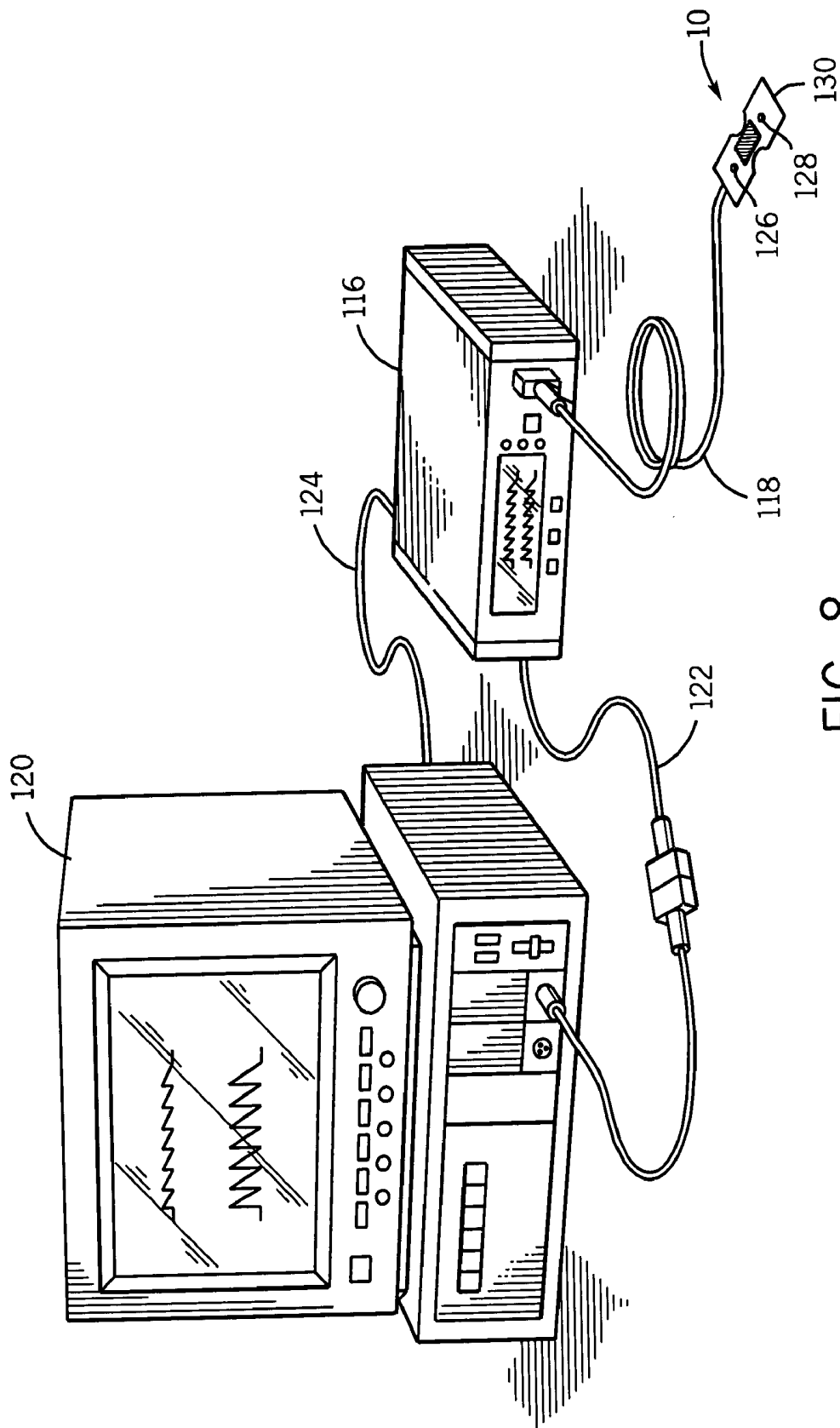

FIG. 8

**MEDICAL SENSOR AND TECHNIQUE FOR USING THE SAME**

## BACKGROUND OF THE INVENTION

**[0001]** 1. Field of the Invention

**[0002]** The present invention relates generally to medical devices and, more particularly, to sensors used for sensing physiological parameters of a patient.

**[0003]** 2. Description of the Related Art

**[0004]** This section is intended to introduce the reader to various aspects of art that may be related to certain aspects of the present invention, which are described and/or claimed below. This discussion is believed to be helpful in providing the reader with background information to facilitate a better understanding of the various aspects of the present invention. Accordingly, it should be understood that these statements are to be read in this light, and not as admissions of prior art.

**[0005]** In the field of medicine, doctors often desire to monitor certain physiological characteristics of their patients. Accordingly, a wide variety of devices have been developed for monitoring many such characteristics of a patient. Such devices provide doctors and other healthcare personnel with the information they need to provide the best possible healthcare for their patients. As a result, such monitoring devices have become an indispensable part of modern medicine.

**[0006]** One technique for monitoring certain physiological characteristics of a patient is commonly referred to as pulse oximetry, and the devices built based upon pulse oximetry techniques are commonly referred to as pulse oximeters. Pulse oximetry measures various blood flow characteristics, such as the blood-oxygen saturation of hemoglobin in arterial blood, the volume of individual blood pulsations supplying the tissue, and/or the rate of blood pulsations corresponding to each heartbeat of a patient. In fact, the "pulse" in pulse oximetry refers to the time varying amount of arterial blood in the tissue during each cardiac cycle.

**[0007]** Pulse oximeters typically utilize a non-invasive sensor that emits light into a patient's tissue and that photoelectrically detects the absorption and/or scattering of the transmitted light in such tissue. One or more of the above physiological characteristics may then be calculated based upon the amount of light absorbed or scattered. More specifically, the light passed through the tissue is typically selected to be of one or more wavelengths that may be absorbed or scattered by the blood in an amount related to the amount of a blood constituent present in the blood. The amount of light absorbed and/or scattered may then be used to estimate the amount of the blood constituent in the tissue using various algorithms.

**[0008]** The pulse oximetry measurement depends in part on the assumption that the contribution of light that has not passed through a patient's tissue is negligible. However, outside light may leak into a sensor, causing detection of light that is not related to the amount of blood constituent present in the blood. Additionally, light from a sensor's emitter may be reflected around the exterior of the tissue and may impinge the detector without traveling first through the

tissue. These light sources may cause measurement variations that do not relate to amount of the blood constituent.

**[0009]** Some outside light infiltration into the sensor may be avoided by fitting the sensor snugly against the patient's tissue. However, such a conforming fit may be difficult to achieve over a range of patient physiologies without adjustment or excessive attention on the part of medical personnel. Additionally, an overly tight fit may cause local exsanguination of the tissue around the sensor. Exsanguinated tissue, which is devoid of blood, may shunt the sensor light through the tissue, which may also result in increased measurement errors.

## SUMMARY

**[0010]** Certain aspects commensurate in scope with the originally claimed invention are set forth below. It should be understood that these aspects are presented merely to provide the reader with a brief summary of certain forms that the invention might take and that these aspects are not intended to limit the scope of the invention. Indeed, the invention may encompass a variety of aspects that may not be set forth below.

**[0011]** There is provided a sensor that includes: a sensor body; an emitter disposed on the sensor body, wherein the emitter is adapted to transmit light into tissue; a detector disposed on the sensor body, wherein the detector is adapted to detect the light; and a patterned region disposed on a tissue-contacting surface of the sensor body between the emitter and the detector, the patterned region being configured to at least absorb, refract, redirect, or diffract the light.

**[0012]** There is also provided a pulse oximetry system that includes: a pulse oximetry monitor; and a pulse oximetry sensor adapted to be operatively coupled to the monitor, the sensor comprising: a sensor body; an emitter disposed on the sensor body, wherein the emitter is adapted to transmit light into tissue; a detector disposed on the sensor body, wherein the detector is adapted to detect the light; and a patterned region disposed on a tissue-contacting surface of the sensor body between the emitter and the detector, the patterned region being configured to at least absorb, refract, redirect, or diffract the light.

**[0013]** There is also provided a method that includes: delivering a first light through a patient's tissue; detecting the first light delivered through the tissue; and redirecting a second light that does not propagate through the tissue away from the detector with a patterned region.

**[0014]** There is also provided a method that includes: providing a sensor body; providing an emitter adapted to transmit light into tissue; providing a detector adapted to detect the light; and providing a patterned region on a tissue-contacting surface of the sensor body between the emitter and the detector, the patterned region being configured to at least absorb, refract, redirect, or diffract the light.

**[0015]** There is also provided a sensor that includes: a sensor body adapted to operate in a transmission mode; an emitter disposed on the sensor body, wherein the emitter is adapted to deliver a first light into a tissue; a detector disposed on the sensor body, wherein the detector is adapted to detect the first light; and at least one protrusion disposed on a tissue-contacting surface of the sensor body, wherein the at least one protrusion is adapted to reduce the amount

of a second light impinging the detector at an incident angle substantially not in-line with an imaginary axis connecting the emitter and the detector.

[0016] There is also provided a pulse oximetry system that includes: a pulse oximetry monitor; and a pulse oximetry sensor adapted to be operatively coupled to the monitor, the sensor comprising: a sensor body adapted to operate in a transmission mode; an emitter disposed on the sensor body, wherein the emitter is adapted to deliver a first light into a tissue; a detector disposed on the sensor body, wherein the detector is adapted to detect the first light; and at least one protrusion disposed on a tissue-contacting surface of the sensor body, wherein the at least one protrusion is adapted to reduce the amount of a second light impinging the detector at an incident angle substantially not in-line with an imaginary axis connecting the emitter and the detector.

[0017] There is also provided a method that includes: delivering a first light through a patient's tissue; detecting the first light delivered through the tissue; and redirecting a second light that does not propagate through the tissue away from the detector with a protruding feature.

[0018] There is also provided a method that includes: providing a transmission-type sensor body; providing an emitter adapted to transmit a first light into tissue; providing a detector adapted to detect the first light; providing at least one protrusion disposed on a tissue-contacting surface of the sensor body, wherein the at least one protrusion is adapted to reduce the amount of a second light impinging the detector at an incident angle substantially not in-line with an imaginary axis connecting the emitter and the detector.

[0019] There is also provided a sensor that includes: a sensor body adapted to operate in a reflectance mode; an emitter disposed on the sensor body, wherein the emitter is adapted to deliver a first light into a tissue; a detector disposed on the sensor body, wherein the detector is adapted to detect the first light; and at least one protrusion disposed on a tissue-contacting surface of the sensor body, wherein the at least one protrusion is adapted to reduce the amount of a second light impinging the detector at an incident angle substantially in-line with an imaginary axis connecting the emitter and the detector.

[0020] There is also provided a pulse oximetry system that includes: a pulse oximetry monitor; and a pulse oximetry sensor adapted to be operatively coupled to the monitor, the sensor comprising: a sensor body adapted to operate in a reflectance mode; an emitter disposed on the sensor body, wherein the emitter is adapted to deliver a first light into a tissue; a detector disposed on the sensor body, wherein the detector is adapted to detect the first light; and at least one protrusion disposed on a tissue-contacting surface of the sensor body, wherein the at least one protrusion is adapted to reduce the amount of a second light impinging the detector at an incident angle substantially in-line with an imaginary axis connecting the emitter and the detector.

[0021] There is also provided a method that includes: providing a sensor body; providing an emitter adapted to transmit a first light into tissue; providing a detector adapted to detect the first light; and providing at least one protrusion adapted to reduce the amount of a second light impinging the detector disposed on a tissue-contacting surface of the sensor body, wherein the second light has an incident angle substantially in-line with an imaginary axis connecting the emitter and the detector.

[0022] There is also provided a sensor that includes: a sensor body; an emitter disposed on the sensor body, wherein the emitter is adapted to transmit a light into tissue; a detector disposed on the sensor body, wherein the detector is adapted to detect the light; and a light diffracting material disposed on a tissue-contacting surface of the sensor body.

#### BRIEF DESCRIPTION OF THE DRAWINGS

[0023] Advantages of the invention may become apparent upon reading the following detailed description and upon reference to the drawings in which:

[0024] FIG. 1A illustrates a perspective view of an embodiment of an exemplary bandage-style sensor with a patterned region in accordance with the present invention;

[0025] FIG. 1B illustrates a perspective view of the sensor of FIG. 1A with a checkerboard patterned region;

[0026] FIG. 1C illustrates a cross-sectional view of the sensor of FIG. 1B applied to a patient's digit;

[0027] FIG. 2 illustrates a cross-sectional view of an exemplary sensor with protruding features applied to a patient's digit;

[0028] FIG. 3 illustrates a cross-sectional view of an exemplary reflectance sensor with protruding features;

[0029] FIG. 4A illustrates a perspective view of an embodiment of an exemplary bandage-style sensor with protruding features in a concentric pattern in accordance with the present invention;

[0030] FIG. 4B illustrates a cross-sectional view of the sensor of FIG. 4A applied to a patient's forehead;

[0031] FIG. 5A illustrates a cross-sectional view of a region of an exemplary sensor with light absorbing protruding features in accordance with the present invention;

[0032] FIG. 5B illustrates a cross-sectional view of a region of an exemplary sensor with protruding features with a light absorbing coating in accordance with the present invention;

[0033] FIG. 5C illustrates a cross-sectional view of a region of an exemplary sensor with light refracting protruding features with a light absorbing backing in accordance with the present invention;

[0034] FIG. 5D illustrates a cross-sectional view of a region of an exemplary sensor with light diffracting protruding features in accordance with the present invention;

[0035] FIG. 6 illustrates exemplary protruding features for use with a sensor in accordance with the present invention;

[0036] FIG. 7 illustrates a cross-sectional view of an exemplary sensor with a light diffracting material in accordance with the present invention; and

[0037] FIG. 8 illustrates a pulse oximetry system coupled to a multi-parameter patient monitor and a sensor according to embodiments of the present invention.

#### DETAILED DESCRIPTION OF SPECIFIC EMBODIMENTS

[0038] One or more specific embodiments of the present invention will be described below.

[0039] In an effort to provide a concise description of these embodiments, not all features of an actual implementation are described in the specification. It should be appreciated that in the development of any such actual implementation, as in any engineering or design project, numerous implementation-specific decisions must be made to achieve the developers' specific goals, such as compliance with system-related and business-related constraints, which may vary from one implementation to another. Moreover, it should be appreciated that such a development effort might be complex and time consuming, but would nevertheless be a routine undertaking of design, fabrication, and manufacture for those of ordinary skill having the benefit of this disclosure.

[0040] It is desirable to eliminate, reduce, or account for the possible influence of light sources which may cause variability in pulse oximetry measurements. In accordance with the present techniques, pulse oximetry sensors are provided that reduce the amount of outside light that impinges the detecting elements of a sensor. Such sensors also reduce the amount of "shunted" light, i.e., light originating from light emitting elements of the sensor that impinges the detecting elements of a sensor without first passing through tissue. Sensors according to the present techniques incorporate surface features on or near the tissue-contacting surface of the sensor, such as protruding elements or printed patterns, to influence the path of light from the undesired light sources and to direct such light away from the detecting elements of the sensor. Such sensors may absorb, refract, or diffract the light originating from these undesired light sources before such light can impinge the detecting elements of the sensor.

[0041] Pulse oximetry sensors are typically placed on a patient in a location that is normally perfused with arterial blood to facilitate measurement of the desired blood characteristics, such as arterial oxygen saturation measurement ( $\text{SpO}_2$ ). The most common sensor sites include a patient's fingertips, toes, earlobes, or forehead. Regardless of the placement of a sensor 10 used for pulse oximetry, the reliability of the pulse oximetry measurement is related to the accurate detection of transmitted light that has passed through the perfused tissue and that has not been supplemented by undesired light sources. Such supplementation and/or modulation of the light transmitted by the sensor can cause variability in the resulting pulse oximetry measurements. The contribution of ambient or shunted light may adversely affect the measurement of the particular blood constituent, such as  $\text{SpO}_2$ .

[0042] In many cases, light from undesired light sources propagates along an optical path that is distinguishable from the optical path of the emitted light that is related to a blood constituent. In a transmission-type sensor, the sensor's emitter and detector lie on opposing sides of the tissue when the sensor is applied to a patient. The optical path of the signal light, which is light originating from the emitter that properly passes through perfused tissue, is substantially in-line with an imaginary axis connecting the emitter and the detector. For reflectance-type sensors, the optical path of the emitted signal light is somewhat more complicated, as the light first enters the perfused tissue and then is scattered back to the detector. In both transmission-type and reflectance-

type sensors, shunted light and ambient light generally propagate at angles substantially off-axis from the optical path of the signal light.

[0043] The exemplary sensors discussed below have surface features that act to divert shunted or ambient light away from the light detecting elements of a sensor. In certain embodiments, those features may be patterns or designs. More specifically, FIG. 1A illustrates a perspective view of an exemplary bandage-style sensor 10 having a generic patterned region 12 disposed on a tissue-contacting surface 14 of the sensor body 16. As one with skill in the art understands, the tissue-contacting surface 14 of the sensor body 16 may be actually touching a patient's tissue, or may be almost touching the patient's tissue, depending on the closeness of the sensor's 10 fit. As depicted, the patterned region 12 is disposed in the region between the emitter 18 and the detector 20. The patterned region 12 may include a material that absorbs, refracts, or diffracts light. The sensor 10 may be applied to a patient's tissue with adhesives bandages 11.

[0044] For example, FIG. 1B illustrates a perspective view of the sensor 10A having a checkerboard pattern 22 disposed on a tissue-contacting surface of the sensor body. As depicted, the checkerboard is an alternating pattern of a light absorbing material 23. The material surrounding the portions of light absorbing material 23 may be the material from which the sensor body 16 is constructed.

[0045] FIG. 1C depicts a cross-sectional view of the sensor 10A with a checkerboard pattern 22 applied to a patient's digit 24. The optical path of signal light originating from the emitter is substantially in-line with an imaginary axis 26 connecting the emitter 18 and the detector 20. A small percentage of the light emitted by the emitter 18 may not enter the perfused digit 24. Instead, this light may be shunted around the space between the digit 24 and the sensor body 16. The shunted light, depicted by wavy arrow 27, impinges the light absorbing material in the checkerboard pattern 22, which absorbs the light, thus preventing it from reflecting around the gap between the sensor body 16 and the digit 24 to impinge the detector 20. It should be understood that the gap between the sensor body 16 and the digit 24 may be microscopic in scale for a sensor body 16 that conforms closely to the digit 24. Further, the gap may be discontinuous when interrupted by points where the sensor body 16 is touching the digit 24. The checkerboard pattern 22 reduces the overall reflectivity of the sensor body 16 on the tissue-contacting surface 14, which may reduce the amount of shunted light that reaches the detector 20. The checkerboard pattern 22, or other suitable pattern or design, may easily be applied to the sensor body 16 with inks or dyes, and is thus a low-cost modification which may reduce measurement errors. In certain embodiments, the patterned region 12 does not protrude from the sensor body 16. However, in other embodiments, as depicted in FIG. 1C, the checkerboard pattern may be laminated onto the sensor body 16 so that it protrudes slightly from the sensor body 16.

[0046] A patterned region 12 may include a first material and a second material. The first material may be the material from which the sensor body is constructed. The second material may be a light absorbing, light refracting, or light diffracting material, or a combination thereof. The patterned region 12 may include more than two materials, and may

also include materials that are intermediate in their ability to absorb, refract, or diffract light. The patterned region 12 may also include an anti-reflective material. In certain embodiments, the patterned region 12 may be a single material that is applied in varying intensity or concentration to the sensor body. For example, a checkerboard pattern 22 may be an alternating pattern of black ink and gray ink.

[0047] Additionally, the patterned region 12 may be a regular pattern, such as a checkerboard pattern 22, a concentric circles pattern, or a striped pattern. The patterned region 12 may also be an irregular pattern that is customized to provide redirection of light in specific areas of the sensor 10 which ambient or shunted light may be most likely to impinge. The patterned region 12 may be microscopic in scale, or it may be visible to the unaided eye. In certain embodiments, it is envisioned that the sensor body 16 is impregnated with the inks, dyes, or paints used to make the patterned region 12.

[0048] Generally, it is envisioned that the patterned region 12 will cover at least 1% of the surface area of the tissue-contacting surface 14 of a sensor body 16. The tissue contacting surface 14 may include only the sensor body 16 or may also include the combined total tissue-contacting area of the sensor body 16 and of the adhesive bandages 11. In certain embodiments, the patterned region 12 will cover 10-50% of the surface area of the tissue-contacting surface 14 of a sensor body 16. In other embodiments, the patterned region may cover at least 75% of the surface area of a tissue-contacting surface 14 of a sensor body 16. Generally, it is contemplated that in addition to disposing a patterned region between an emitter 18 and detector 20, it may be advantageous to dispose a patterned region near any edges of the sensor 10A that may allow ambient light to infiltrate into a sensor's 10 interior.

[0049] Furthermore, the patterned region 12 may have three-dimensional protruding surface features that function to divert ambient or shunted light away from the light detecting elements of the sensor. FIG. 2 depicts a cross-sectional view of a transmission-type sensor 10B applied to a patient digit 28. The sensor 10B has protruding surface features 30 disposed on the tissue-contacting surface 32 of the sensor body 34. The protruding surface features 30 may be integrally formed or molded with the sensor body 34, or they may be applied to the tissue-contacting surface 32 of the sensor body 34 adhesively or otherwise. The protruding surface features 30 may be small-scale protruding features. Generally, small-scale protruding features as described herein are contemplated to protrude less than about 0.001 mm from the tissue-contacting surface 32 of the sensor body 34. In certain embodiments, the small-scale protruding features are not visible to the unaided eye. Alternatively, the protruding surface features 30 may be large-scale protruding features. Generally, large-scale protruding features as described herein are clearly visible to the unaided eye, and they are contemplated to protrude at least about 0.001 mm from the tissue-contacting surface 32 of the sensor body 34. In certain embodiments, the large-scale protruding features protrude about 0.001 mm to about 1 mm from the tissue-contacting surface 32 of the sensor body 34. The protruding features may be sized and shaped to avoid substantially interfering with a suitably conforming sensor fit.

[0050] Turning to FIG. 2 in greater detail, the optical path of signal light originating from the emitter is substantially

in-line with an imaginary axis 36 connecting the emitter 40 and the detector 42. However, a small percentage of the light from the emitter, illustrated by wavy arrow 38, may not pass through the perfused tissue, but instead may be reflected off the surface of the digit 28 and shunted around the gap between the digit 28 and the tissue-contacting surface 32 of the sensor body 34. As the shunted light, wavy arrow 38, propagates along its optical path, it impinges the protruding features 30 on the tissue-contacting surface 32. The protruding features 30 change the optical path of the shunted light, reducing the amount of shunted light that impinges on the detector 42.

[0051] The sensor 10B may also reduce the contribution of outside light sources to pulse oximetry measurements. Ambient light, depicted as wavy arrow 44, is shown leaking into the sensor 10B and impinging on the protruding features 30. The protruding features 30 reduce the amount of ambient light that reaches the detector 42. As the protruding features 30 are not in-line with the imaginary axis 36, the optical path of the light transmitted by the emitter 40 into the digit 28 is not substantially affected by the protruding features 30. Hence, the contribution of shunted light and ambient to the light received by the detector 42 is reduced, thus improving the signal to noise ratio.

[0052] In certain embodiments, it may be advantageous to use large-scale protruding features, as described above, to redirect light from undesired light sources away from a detector. For example, when using reflectance type sensors, it may be useful to block light that may shunt directly between the emitter and detector of such a sensor. FIG. 3 illustrates a cross-sectional view of a reflectance-type sensor 10C with large-scale protruding features 46 adapted to block light from the emitter 48 that shunts directly to the detector 50 without first passing through perfused tissue. In certain embodiments, a light shunt between the emitter 48 and the detector 50 may be addressed by placing one or more large-scale protruding features 46 on the tissue-contacting surface 52 of the sensor body 54 between the emitter 48 and the detector 50. As the emitted light, depicted by wavy arrow 56, strikes the side of the large-scale protruding features 46, it will be redirected away from the detector 50. As depicted, the large-scale protruding features 46 are heterogeneous in size, and they are arranged such that the protruding features 46 closest to the detector 50 protrude the most from the sensor body 54. In certain embodiments, at least one of the large-scale surface features 46 should protrude from the tissue-contacting surface 52 of the sensor body 54 at least as far as the detector 50 protrudes from the tissue-contacting surface 52 of the sensor body 54.

[0053] In another embodiment, shown in FIGS. 4A and 4B, large-scale protruding features may be arranged to form a pattern. FIG. 4A is a perspective view of a forehead sensor 10D with protruding features 56 arranged in concentric circles that substantially encircle an emitter 58 and a detector 60. FIG. 4B is a cross-sectional view of the sensor 10D applied to a patient's forehead. Such an arrangement of protruding features 56 may be advantageous in forming a seal with the tissue 62, thus creating a barrier against any ambient light or shunted light that may leak into the sensor 10D. The ambient light, depicted by wavy arrows 64, impinges the protruding features and is prevented from reaching the detector 60.

[0054] The optical path of the signal light, depicted by wavy arrow 66, is substantially unaffected by the protruding features 56.

[0055] In general, when shunted or ambient light impinges the protruding features, as described above, its optical path is altered and redirected away from the detector of a sensor 10. This may be accomplished in a variety of ways, as seen in FIGS. 5A-D, which depict cross-sectional views of exemplary sensor bodies with protruding features dispersed in the patterned area 12. It should be understood that any of the protruding features described below in FIGS. 5A-D may be large-scale or small-scale, and they may be used alone or in combination with one another on any suitable sensor.

[0056] For example, as depicted in FIG. 5A, protruding features 68 may be made of a light-absorbing material. The impinging light, depicted as wavy arrow 70, is refracted into the bulk of the light-absorbing material where it is absorbed. In another embodiment, as seen in FIG. 5B, protruding features 72 may have a light-absorbing coating 74. The impinging light, depicted by wavy arrow 76, is absorbed as it contacts the light-absorbing coating 74 of the protruding features 72. In another embodiment, shown in FIG. 5C, protruding features 78 may be made of a substantially optically refractive material with an absorptive backing 80. The light, depicted by wavy arrow 82, is refracted into the refractive material of the protruding features 78, and the refracted light, depicted by wavy arrow 84, is absorbed by the absorptive backing 80.

[0057] Alternatively, in another embodiment, shown in FIG. 5D, light from undesired light sources may be directed away from the detector through diffraction. In such an embodiment, protruding features 86 may be made of a diffracting material. For example, the diffracting material may be an interference grating material. As the impinging light, depicted by wavy arrow 88, impinges the protruding features 86, it is diffracted into destructively interfering beams, depicted by wavy arrows 90 and 92, that substantially cancel each other out. It is contemplated that the diffracting material may be adapted to selectively interfere with at least certain wavelengths. Thus, all or certain wavelengths of the impinging light may be prevented from reaching a detector.

[0058] As described above, it may be advantageous to refract a beam of light when it impinges a protruding feature as described herein. Ambient light or shunted light may impinge a protruding feature after propagating through air in the gap between the tissue and the sensor body. Alternatively, if the protruding feature is pressed tightly against the tissue, the light may travel through the cutaneous layer of the tissue to impinge the protruding feature. Light that impinges a protruding feature at an incident angle not normal, i.e., not 90 degrees, to the interface of the protruding feature with the air or tissue and the protruding feature will tend to be refracted. Thus, the protruding features may be shaped to promote light refraction. For example, as shown in FIG. 6, the protruding feature may have a generally sawtooth shape 94, which may be nonorthogonal to incident light leaking in. In another embodiment, a protruding feature 96 may have a complex profile in order to present a variety of possible interfaces to impinging light. Alternatively, a protruding feature 98 may have a curved profile to promote refraction.

In certain embodiments, it is contemplated that the protruding features may incorporate a patterned region, as described herein, on their surfaces.

[0059] As described above in FIG. 5D, materials with light diffracting properties may direct light from undesired light sources away from the detecting elements of a sensor. FIG. 7 is a cross-sectional view of an alternate embodiment of a sensor 10E with a light diffracting material 100 disposed as a thin layer on a tissue-contacting surface 102 of the sensor body 104 applied to a patient's digit 106. The light diffracting material 100 is disposed in a region between an emitter 108 and a detector 110. Light shunted by the emitter 108, depicted by wavy arrow 112, impinges the light diffracting material 100. The light diffracting material reduces the reflectivity of the shunted light by "smearing" the light into multiple component wavelengths 114, many of which may interfere. The shunted light is thus prevented from reflecting around the gap between the sensor body 104 and the digit 106 to impinge the detector 110. It is contemplated that the diffracting material as described here and in FIG. 5D may be customized to selectively reduce certain wavelengths. Specifically, the slit pattern of diffraction grating may be optimized.

[0060] It should be appreciated that sensors as described herein may include light absorbing materials, light refracting materials, light diffracting materials, or any combination thereof.

[0061] For example, a tissue-contacting surface, including all or part of any patterned regions or protruding features as described above, of a sensor body may be formed from, coated with, or impregnated with such materials. It should also be appreciated that, as discussed above, the sensor body may contain such materials only on a tissue-contacting surface, or, in alternate embodiments, the sensor body may be constructed entirely from such materials in appropriate regions as described herein.

[0062] It should also be appreciated that light absorbing materials may be adapted to absorb light at a particular wavelength. In certain embodiments, when light absorbing material is disposed between an emitter and a detector of a sensor, it may be advantageous to use light absorbing material that absorbs a wavelength emitted by the emitter in order to absorb shunted light from the emitter. For example, a light absorbing material may absorb at least about 50% of one or more wavelengths of light from the emitter, or may absorb a range of 50% to 95% of one or more wavelengths of light from the emitter. A light absorbing material may also absorb at least about 90% to at least 95% of one or more wavelengths of visible light and near-infrared light. In a specific embodiment, a pulse oximetry sensor may emit at least one wavelength of light in the wavelength range of 500 nm-1000 nm. For example, a sensor may emit light and wavelengths of 660 nm and 900 nm, which are wavelengths that may be absorbed by dark pigment. In other embodiments, when the light absorbing material is disposed near the edges of a sensor in order to absorb ambient light, which includes multiple wavelengths of light, it may be desirable to use an absorptive material that is adapted to absorb a broad range of wavelengths. Examples of light absorbing materials may include, but are not limited to, black or dark pigment, black or dark woven fabric or cloth, and infrared blockers.

[0063] Keeping in mind the preceding points, the exemplary sensor designs herein are provided as examples of sensors that increase the amount of light collected by a sensor 10 that has passed through perfused tissue while reducing or eliminating outside light and/or shunted light. It should be appreciated that a sensor 10 according to the present teachings may be adapted for use on any digit, and may also be adapted for use on a forehead, earlobe, or other sensor site. For example, a sensor 10 may be a clip-style sensor, appropriate for a patient earlobe or digit. Alternatively, a sensor 10 may be a bandage-style or wrap-style sensor for use on a digit or forehead.

[0064] A sensor, illustrated generically as a sensor 10, may be used in conjunction with a pulse oximetry monitor 116, as illustrated in FIG. 8. It should be appreciated that the cable 118 of the sensor 10 may be coupled to the monitor 116 or it may be coupled to a transmission device (not shown) to facilitate wireless transmission between the sensor 10 and the monitor 116. The monitor 116 may be any suitable pulse oximeter, such as those available from Nellcor Puritan Bennett Inc. Furthermore, to upgrade conventional pulse oximetry provided by the monitor 116 to provide additional functions, the monitor 116 may be coupled to a multi-parameter patient monitor 120 via a cable 122 connected to a sensor input port or via a cable 124 connected to a digital communication port.

[0065] The sensor 10 includes an emitter 126 and a detector 128 that may be of any suitable type. For example, the emitter 126 may be one or more light emitting diodes adapted to transmit one or more wavelengths of light in the red to infrared range, and the detector 128 may be a photodetector selected to receive light in the range or ranges emitted from the emitter 126. For pulse oximetry applications using either transmission or reflectance type sensors the oxygen saturation of the patient's arterial blood may be determined using two or more wavelengths of light, most commonly red and near infrared wavelengths. Similarly, in other applications, a tissue water fraction (or other body fluid related metric) or a concentration of one or more biochemical components in an aqueous environment may be measured using two or more wavelengths of light, most commonly near infrared wavelengths between about 1,000 nm to about 2,500 nm. It should be understood that, as used herein, the term "light" may refer to one or more of infrared, visible, ultraviolet, or even X-ray electromagnetic radiation, and may also include any wavelength within the infrared, visible, ultraviolet, or X-ray spectra.

[0066] The emitter 126 and the detector 128 may be disposed on a sensor body 130, which may be made of any suitable material, such as plastic, rubber, silicone, foam, woven material, or paper. Alternatively, the emitter 126 and the detector 128 may be remotely located and optically coupled to the sensor 10 using optical fibers. In the depicted embodiments, the sensor 10 is coupled to a cable 118 that is responsible for transmitting electrical and/or optical signals to and from the emitter 126 and detector 128 of the sensor 10. The cable 118 may be permanently coupled to the sensor 10, or it may be removably coupled to the sensor 10—the latter alternative being more useful and cost efficient in situations where the sensor 10 is disposable.

[0067] The sensor 10 may be a "transmission type" sensor. Transmission type sensors include an emitter 126 and detec-

tor 128 that are typically placed on opposing sides of the sensor site. If the sensor site is a fingertip, for example, the sensor 10 is positioned over the patient's fingertip such that the emitter 126 and detector 128 lie on either side of the patient's nail bed. In other words, the sensor 10 is positioned so that the emitter 126 is located on the patient's fingernail and the detector 128 is located 180° opposite the emitter 126 on the patient's finger pad. During operation, the emitter 126 shines one or more wavelengths of light through the patient's fingertip and the light received by the detector 128 is processed to determine various physiological characteristics of the patient. In each of the embodiments discussed herein, it should be understood that the locations of the emitter 126 and the detector 128 may be exchanged. For example, the detector 128 may be located at the top of the finger and the emitter 126 may be located underneath the finger. In either arrangement, the sensor 10 will perform in substantially the same manner.

[0068] Reflectance type sensors generally operate under the same general principles as transmittance type sensors. However, reflectance type sensors include an emitter 126 and detector 128 that are typically placed on the same side of the sensor site. For example, a reflectance type sensor may be placed on a patient's fingertip or forehead such that the emitter 126 and detector 128 lie side-by-side. Reflectance type sensors detect light photons that are scattered back to the detector 128.

[0069] While the invention may be susceptible to various modifications and alternative forms, specific embodiments have been shown by way of example in the drawings and have been described in detail herein. However, it should be understood that the invention is not intended to be limited to the particular forms disclosed. Indeed, the present techniques may not only be applied to measurements of blood oxygen saturation, but these techniques may also be utilized for the measurement and/or analysis of other blood constituents using principles of pulse oximetry. For example, using the same, different, or additional wavelengths, the present techniques may be utilized for the measurement and/or analysis of carboxyhemoglobin, met-hemoglobin, total hemoglobin, intravascular dyes, and/or water content. Rather, the invention is to cover all modifications, equivalents, and alternatives falling within the spirit and scope of the invention as defined by the following appended claims.

1. A sensor comprising:

a sensor body;

an emitter disposed on the sensor body, wherein the emitter is adapted to transmit light into tissue;

a detector disposed on the sensor body, wherein the detector is adapted to detect the light; and

a patterned region disposed on a tissue-contacting surface of the sensor body between the emitter and the detector, the patterned region being configured to at least absorb, refract, redirect, or diffract the light.

2. The sensor, as set forth in claim 1, wherein the patterned region comprises a light absorbing material.

3. The sensor, as set forth in claim 1, wherein the patterned region is disposed on at least 10% of the tissue-contacting surface of the sensor body.

4. A pulse oximetry system comprising:  
 a pulse oximetry monitor; and  
 a pulse oximetry sensor adapted to be operatively coupled to the monitor, the sensor comprising:  
 a sensor body;  
 an emitter disposed on the sensor body, wherein the emitter is adapted to transmit light into tissue;  
 a detector disposed on the sensor body, wherein the detector is adapted to detect the light; and  
 a patterned region disposed on a tissue-contacting surface of the sensor body between the emitter and the detector, the patterned region being configured to at least absorb, refract, redirect, or diffract the light.
5. The system, as set forth in claim 4, wherein the sensor comprises at least one of a pulse oximetry sensor or a sensor for measuring a water fraction.
6. A method comprising:  
 delivering a first light through a patient's tissue;  
 detecting the first light delivered through the tissue; and  
 redirecting a second light that does not propagate through the tissue away from the detector with a patterned region.
7. The method, as set forth in claim 6, comprising refracting the second light.
8. A method of manufacturing a sensor, the method comprising:  
 providing a sensor body;  
 providing an emitter adapted to transmit light into tissue;  
 providing a detector adapted to detect the light; and  
 providing a patterned region on a tissue-contacting surface of the sensor body between the emitter and the detector, the patterned region being configured to at least absorb, refract, redirect, or diffract the light.
9. The method, as set forth in claim 8, wherein the patterned region is microscopic in scale.
- 10.-19. (canceled)
20. A sensor comprising:  
 a sensor body;  
 an emitter disposed on the sensor body, wherein the emitter is adapted to transmit a light into tissue;  
 a detector disposed on the sensor body, wherein the detector is adapted to detect the light; and  
 a light diffracting material disposed on a tissue-contacting surface of the sensor body.
21. The sensor, as set forth in claim 20, wherein the light diffracting material is adapted to destructively interfere with a wavelength of light emitted by the emitter.
22. The sensor, as set forth in claim 1, wherein the sensor comprises at least one of a pulse oximetry sensor or a sensor for measuring a water fraction.
23. The sensor, as set forth in claim 1, wherein the emitter comprises at least one light emitting diode.
24. The sensor, as set forth in claim 1, wherein the detector comprises at least one photodetector.
25. The sensor, as set forth in claim 2, wherein the light absorbing material comprises a substantially dark material.
26. The sensor, as set forth in claim 2, wherein the light absorbing material is adapted to absorb light at a wavelength emitted by the emitter.
27. The sensor, as set forth in claim 1, wherein the patterned region comprises a light diffracting material.
28. The sensor, as set forth in claim 27, wherein the light diffracting material is adapted to destructively interfere with light at a wavelength emitted by the emitter.
29. The sensor, as set forth in claim 1, wherein the patterned region comprises a light refracting material.
30. The sensor, as set forth in claim 1, wherein the patterned region comprises alternating regions of a first material and a second material.
31. The sensor, as set forth in claim 1, wherein the patterned region comprises an ink or dye.

\* \* \* \* \*

专利名称(译)	医疗传感器及其使用技术		
公开(公告)号	<a href="#">US20070073123A1</a>	公开(公告)日	2007-03-29
申请号	US11/241508	申请日	2005-09-29
[标]申请(专利权)人(译)	RARIDAN WILLIAM乙JR		
申请(专利权)人(译)	RARIDAN WILLIAM乙JR		
当前申请(专利权)人(译)	COVIDIEN LP		
[标]发明人	RARIDAN WILLIAM B JR		
发明人	RARIDAN, WILLIAM B. JR.		
IPC分类号	A61B5/00		
CPC分类号	A61B5/14552 A61B5/6838 A61B5/6826		
其他公开文献	US7904130		
外部链接	<a href="#">Espacenet</a>	<a href="#">USPTO</a>	

摘要(译)

医学传感器可以适于考虑导致脉搏血氧测量或其他分光光度测量中的不规则性的因素。传感器具有表面特征，其减少了撞击传感器的检测元件的外部光或分流光的量。该传感器适用于减少外部光或分流光对脉搏血氧饱和度测量的影响。

