



(19) **United States**

(12) **Patent Application Publication**  
**Petersen et al.**

(10) **Pub. No.: US 2005/0184895 A1**

(43) **Pub. Date: Aug. 25, 2005**

(54) **MULTI-BIT ADC WITH SIGMA-DELTA MODULATION**

(22) Filed: **Feb. 25, 2004**

**Publication Classification**

(75) Inventors: **Ethan Petersen**, Castro Valley, CA (US); **William Shea**, Livermore, CA (US); **Bradford B. Chew**, San Ramon, CA (US)

(51) **Int. Cl.<sup>7</sup> ..... H03M 3/00**

(52) **U.S. Cl. .... 341/143**

Correspondence Address:  
**TOWNSEND AND TOWNSEND AND CREW, LLP**  
**TWO EMBARCADERO CENTER**  
**EIGHTH FLOOR**  
**SAN FRANCISCO, CA 94111-3834 (US)**

(57) **ABSTRACT**

An oximeter uses a sigma-delta modulator and a multi-bit ADC with PWM feedback enabling high precision multi-bit conversion. Demodulation is done in software, thus requiring only a single hardware path for both red and IR. Multiple capacitors are switched into the integrator in the sigma-delta modulator, with different capacitors for red, IR and dark signals, thus enabling the use of the single hardware path. A switching circuit at the input of the sigma-delta modulator acts as a sample and hold, controlled by the PWM feedback.

(73) Assignee: **Nellcor Puritan Bennett Inc.**, Pleasanton, CA

(21) Appl. No.: **10/787,542**

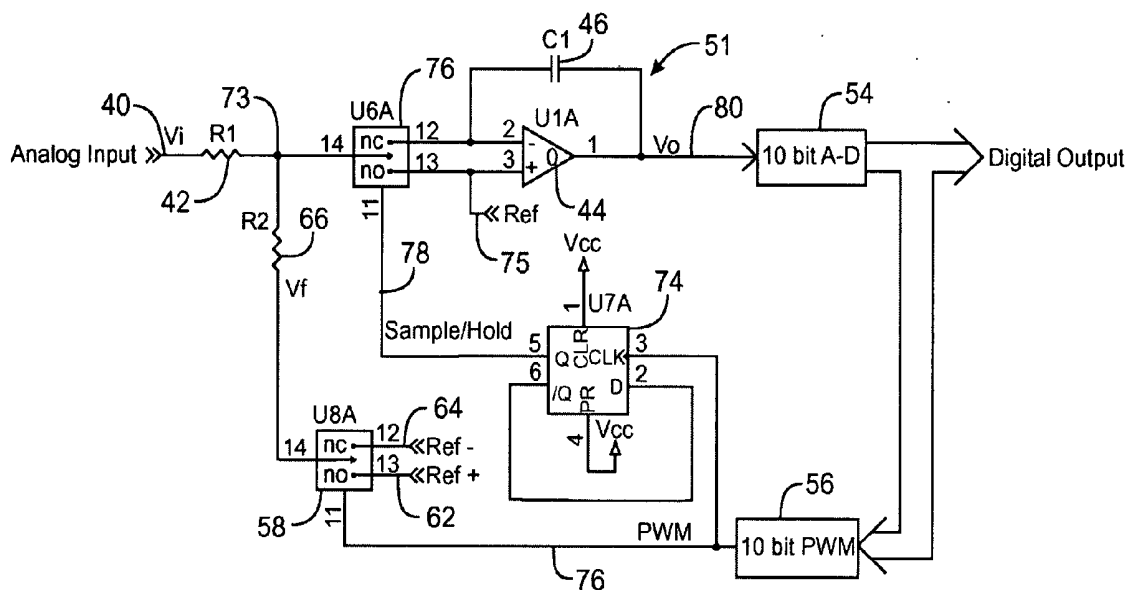

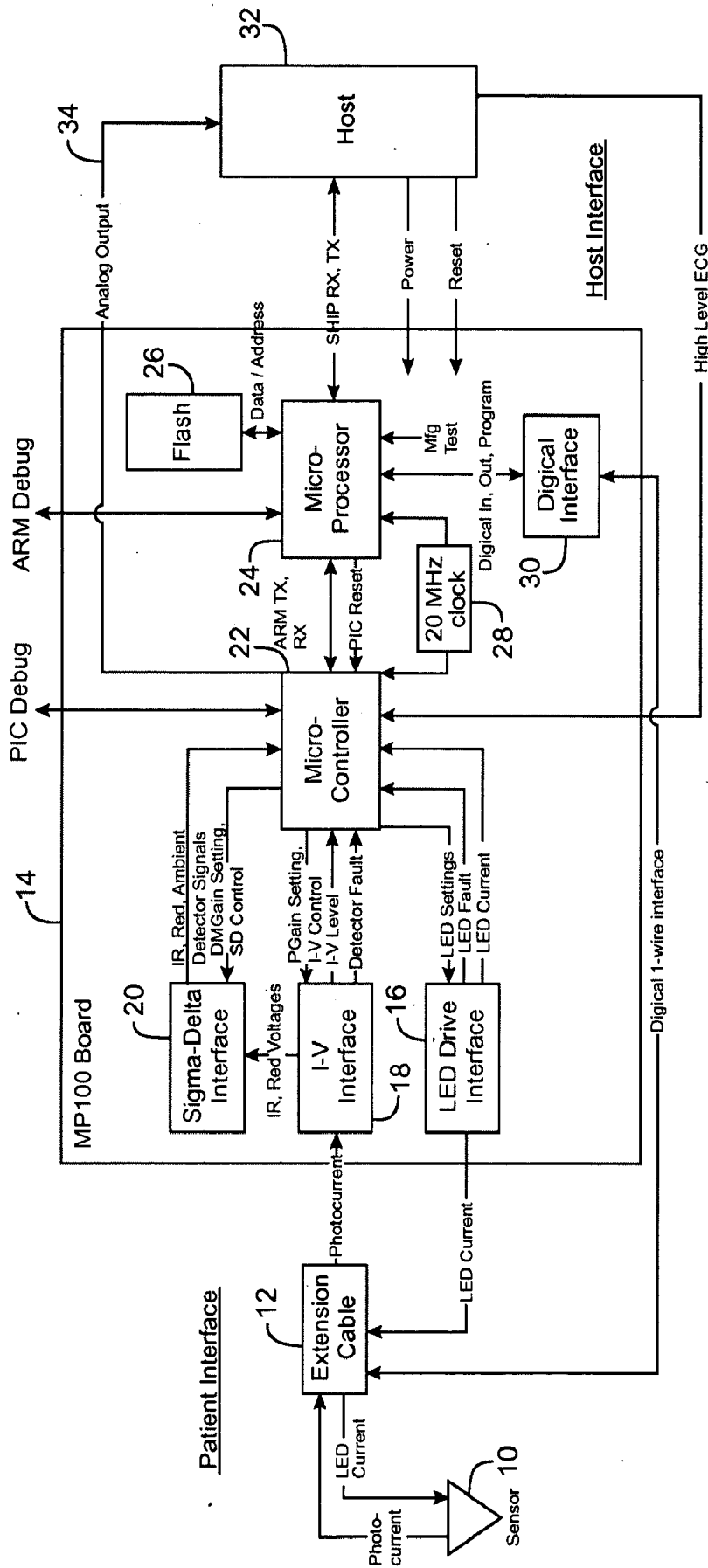

FIG. 1

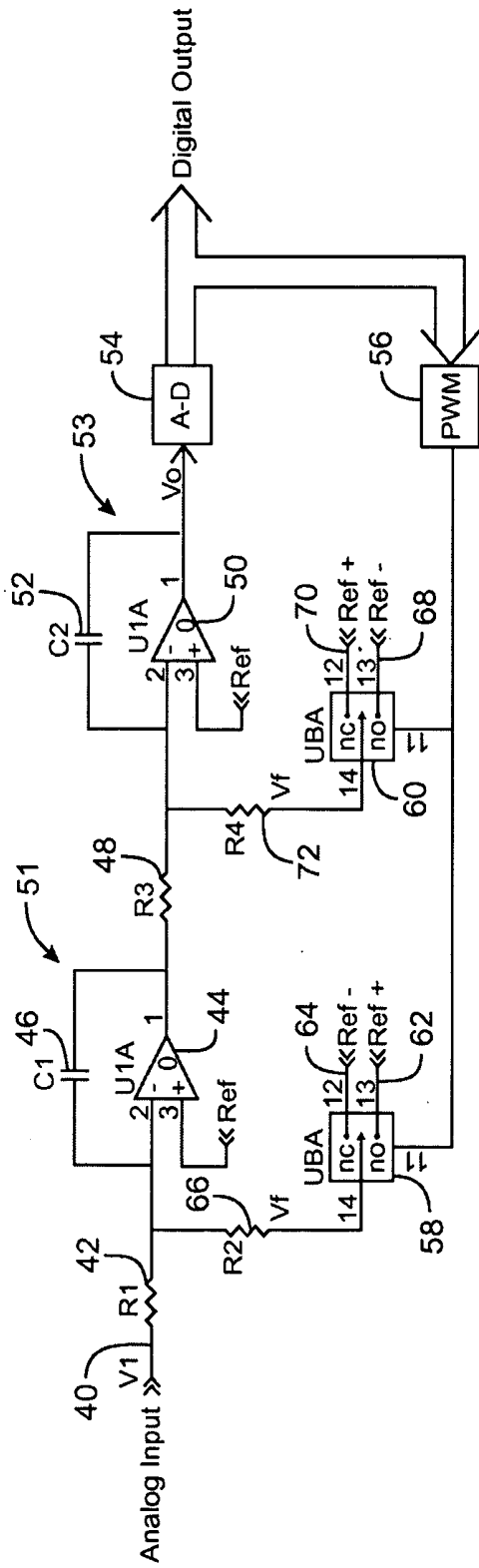

FIG. 2

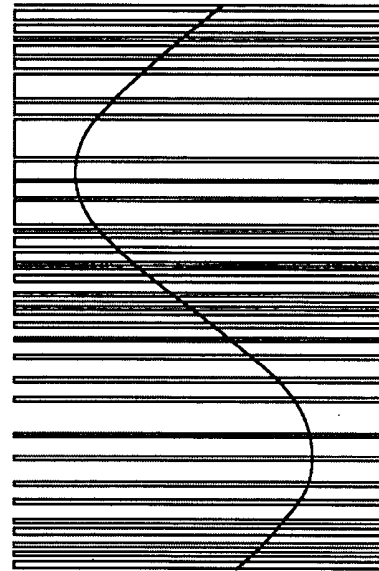

FIG. 3

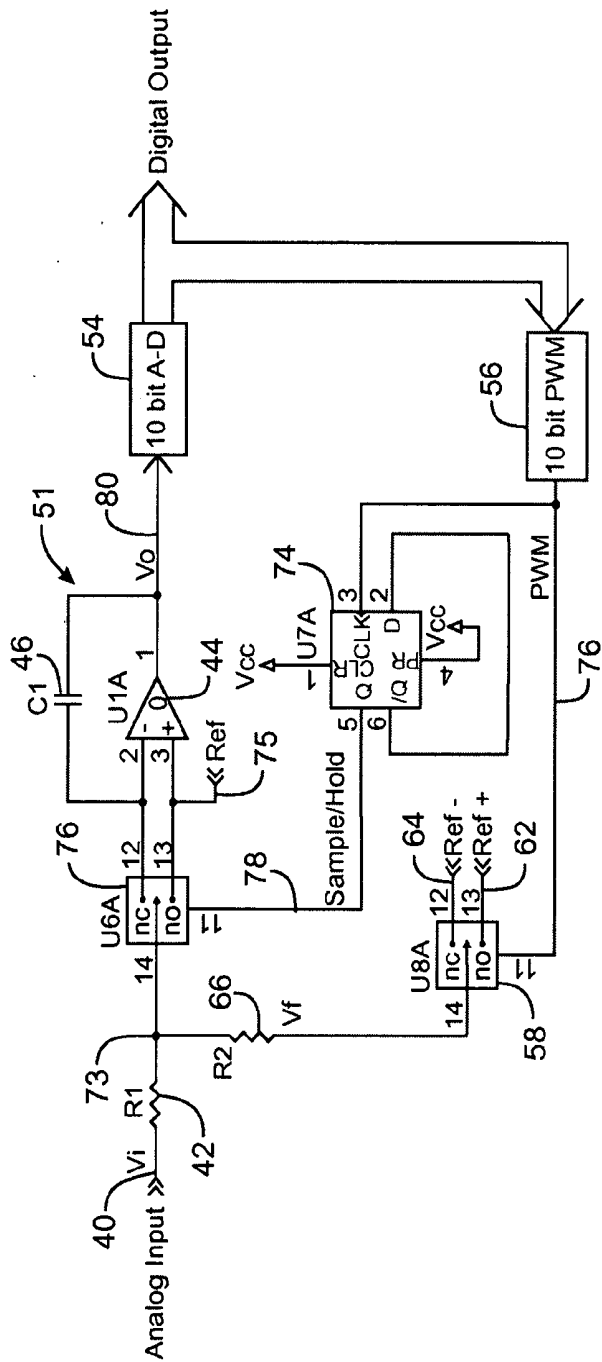

FIG. 4

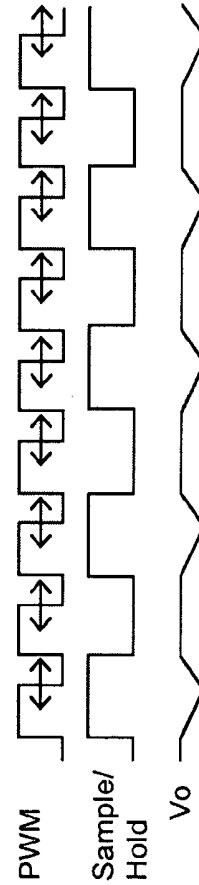

FIG. 5

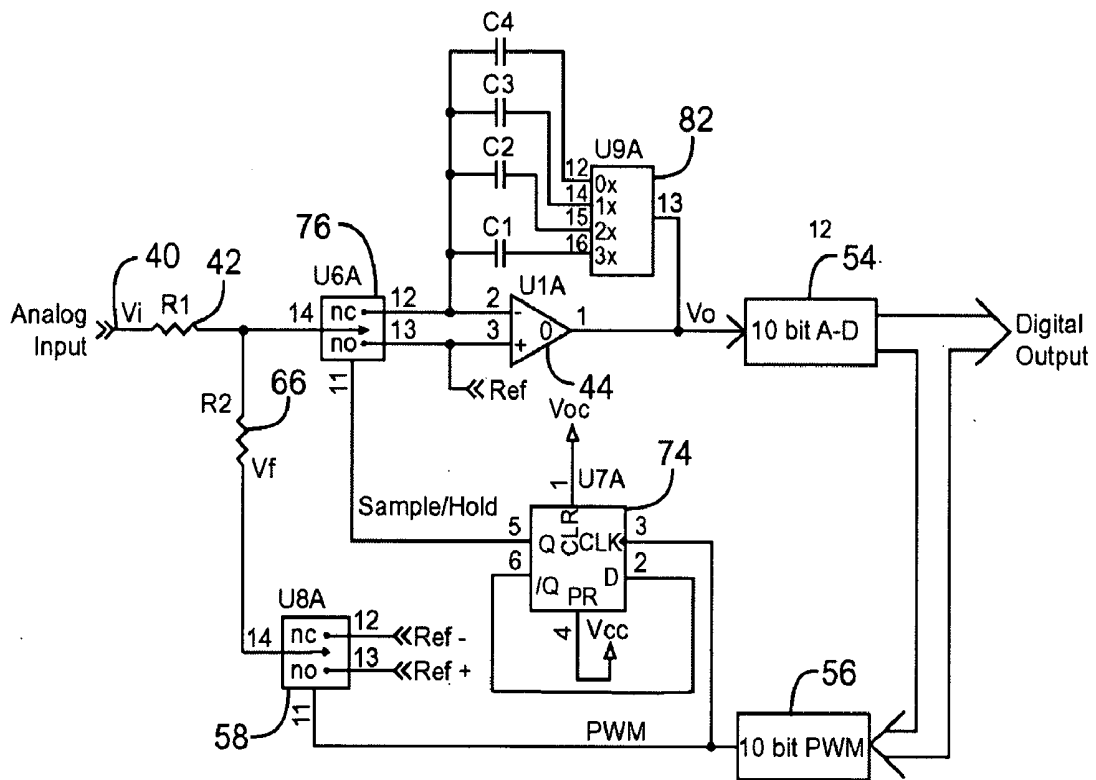

FIG. 6

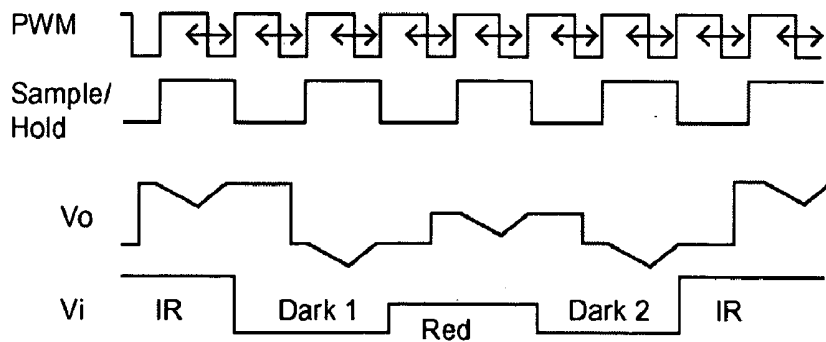

FIG. 7

## MULTI-BIT ADC WITH SIGMA-DELTA MODULATION

### BACKGROUND OF THE INVENTION

[0001] The present invention relates to oximeters, and in particular to sigma-delta modulators used in connection with analog-to-digital conversion in pulse oximeters.

[0002] Pulse oximetry is typically used to measure various blood chemistry characteristics including, but not limited to, the blood-oxygen saturation of hemoglobin in arterial blood, the volume of individual blood pulsations supplying the tissue, and the rate of blood pulsations corresponding to each heartbeat of a patient. Measurement of these characteristics has been accomplished by use of a non-invasive sensor which scatters light through a portion of the patient's tissue where blood perfuses the tissue, and photoelectrically senses the absorption of light at various wavelengths in such tissue. The amount of light absorbed is then used to calculate the amount of blood constituent being measured.

[0003] The light scattered through the tissue is selected to be of one or more wavelengths that are absorbed by the blood in an amount representative of the amount of the blood constituent present in the blood. The amount of transmitted light scattered through the tissue will vary in accordance with the changing amount of blood constituent in the tissue and the related light absorption. For measuring blood oxygen level, such sensors have typically been provided with a light source that is adapted to generate light of at least two different wavelengths, and with photodetectors sensitive to both of those wavelengths, in accordance with known techniques for measuring blood oxygen saturation.

[0004] Known non-invasive sensors include devices that are secured to a portion of the body, such as a finger, an ear or the scalp. In animals and humans, the tissue of these body portions is perfused with blood and the tissue surface is readily accessible to the sensor.

[0005] Typically, the analog-to-digital conversion in a pulse oximeter is done using a sigma-delta modulator for analog-to-digital conversion after the signal is demodulated into the separate red and IR signals. An example of a pulse oximeter circuit using sigma-delta modulators is set forth in U.S. Pat. No. 5,921,921. This patent shows the use of two sigma-delta modulators, one for the red channel and one for the IR (infrared) channel. The sigma-delta modulators provide 1-bit of digital resolution, with the output of the sigma-delta modulator being filtered to produce a higher resolution signal. This is accomplished by using a fast oversampling rate (typically 1200 Hz) and then filtering to produce the slow, high resolution signal. The gain of the sigma-delta modulator in this patent is controlled by varying the width of the feedback pulse.

### BRIEF SUMMARY OF THE INVENTION

[0006] The present invention moves the demodulator into the software domain, after the Analog-to-digital Converter (ADC). A sigma-delta modulator is used with a simple ADC. This allows the use of a single signal path for the photo current signal, rather than demodulating into red and IR components as in the prior art, which required two ADCs. The red and IR signals are separated later, in the digital domain using a software or firmware program. By using the

same hardware for both red and IR, there is no gain error introduced into one signal but not the other. Since the red and IR will have the same frequency response error, the calculation of blood oxygenation will cancel out this error. The demodulation in software also allows a more sophisticated demodulation scheme to be used.

[0007] The present invention is able to produce an accurate multi-bit ADC conversion with the sigma-delta modulator, rather than the single bit conversion of the prior art, by using a multi-bit feedback Digital-to-analog Converter (DAC) to provide a unique Pulse Width Modulated (PWM) feedback. The feedback DAC is clocked by a stable clock to provide a control output which controls a switch between two voltage references, which are added back into the input signal. The amount of time the high voltage reference is added in versus the amount the low voltage reference is added in provides a PWM signal to give an accurate analog feedback. The invention reduces linearity errors since the feedback is a function of a stable clock signal.

[0008] In another aspect of the invention, a switch at the input of the integrator used for the sigma-delta modulator provides a sample and hold circuit. An analog switch is used to switch between the non-inverting and inverting inputs of the operational amplifier of the integrator. The connection to the other input of the operational amplifier maintains the voltage of the input to the switch at the same voltage level. A voltage reference is connected to this second input (e.g., the non-inverting input) to provide a source or sink for excess current, as needed.

[0009] In another aspect of the present invention, multiple capacitors are used for the integrator of the sigma-delta modulator. Different capacitors are switched in depending upon the input signal received. This allows a single sigma-delta modulator and ADC since a different capacitor can be dedicated to each signal to be demodulated. For example, a first capacitor can be used for a red signal and a second for the infrared signal. Additionally, third and fourth capacitors can be used for a first dark signal in between the red and infrared, or a second dark signal between the infrared and red. Thus, each capacitor stores the quantization error for a particular time slot, which allows the sigma-delta modulator ADC to operate on the signal before demodulation.

[0010] For a further understanding of the nature and advantages of the present invention, reference should be made to the following description taken in conjunction with the accompanying drawings.

### BRIEF DESCRIPTION OF THE DRAWINGS

[0011] FIG. 1 is a block diagram of an oximeter incorporating the present invention.

[0012] FIG. 2 is a circuit diagram of a two-stage sigma-delta modulator according to an embodiment of the invention.

[0013] FIG. 3 is a diagram of a typical sigma-delta modulator output.

[0014] FIG. 4 is a circuit diagram of a sigma-delta modulator according to an embodiment of the present invention using the sigma-delta modulator for a sample and hold circuit with an analog switch to avoid charge injection.

[0015] FIG. 5 is a timing diagram illustrating various signals of the circuit of FIG. 4.

[0016] FIG. 6 is a circuit diagram of an embodiment of a sigma-delta modulator according to the present invention utilizing multiple capacitors in the integrator.

[0017] FIG. 7 is a timing diagram illustrating different signals of the circuit of FIG. 6.

#### DETAILED DESCRIPTION OF THE INVENTION

[0018] Overall System

[0019] FIG. 1 illustrates an embodiment of an oximetry system incorporating the present invention. A sensor 10 includes red and infrared LEDs and a photodetector. These are connected by a cable 12 to a board 14. LED drive current is provided by an LED drive interface 16. The received photocurrent from the sensor is provided to an I-V interface 18. The IR and red voltages are then provided to a sigma-delta interface 20 incorporating the present invention. The output of sigma-delta interface 20 is provided to a microcontroller 22 which includes a 10 bit A/D converter. Microcontroller 22 includes flash memory for a program, and RAM memory for data. The oximeter also includes a microprocessor chip 24 connected to a flash memory 26. Finally, a clock 28 is used and an interface 30 to a digital calibration in the sensor 10 is provided. A separate host 32 receives the processed information, as well as receiving an analog signal on a line 34 for providing an analog display.

[0020] By using a sigma-delta modulator with the unique PWM feedback of the present invention, the simple, internal ADC of microcontroller 22 can be used and still provide the desired multi-bit precision. The ADC in this embodiment is a 10 bit successive approximation ADC. The precisely controlled PWM feedback connects in a voltage reference through switches 58 and 60, which are then summed in summing nodes with the input signal at the inputs of the integrators. The averaged summed value, between the positive and negative reference voltages, provide the desired feedback. Any error is fed back in the following pulse period.

[0021] Sigma-Delta Modulator

[0022] FIG. 2 is a circuit diagram of a sigma-delta modulator according to an embodiment of the present invention, including portions of sigma-delta interface 20 and microcontroller 22 of FIG. 1. In particular, an analog input on a line 40 is provided through a resistor 42 to an inverting input of an operational amplifier 44 configured as an integrator 51 with a feedback capacitor 46. The non-inverting input is connected to a reference voltage (Ref). This is followed, through a connecting resistor 48, by a second operational amplifier 50, connected as an integrator 53 with a feedback capacitor 52. The output of operational amplifier 50 is connected to an analog-to-digital converter 54, which is the 10-bit A/D converter in microcontroller 22 of FIG. 1.

[0023] The digital output is fed back through a "digital-to-analog converter" 56 as a feedback circuit through a first switching circuit 58 and a second switching circuit 60. DAC 56 is internal to microcontroller 22, and produces the PWM output signal shown in FIG. 5. In response to the PWM control signal, switching circuit 58 alternately connects a

positive or negative reference on lines 62 and 64 through a resistor 66 to connect with the input signal to the inverting input of operational amplifier 44. Similarly, second switching circuit 60 connects a negative and positive reference, inverted from the connections shown for switching circuit 58. These are reference voltages 68 and 70, which are connected through a resistor 72 to the inverting input of operational amplifier 50.

[0024] The feedback signal from digital-to-analog converter 56 is a pulse width modulated (PWM) signal, such as the typical signal shown in FIG. 3 for a sigma-delta modulator illustrating a sine waveform. By using a PWM signal and switching between only two voltages, the linearity of the feedback is a function of the clock signal. Since the clock signal is stable, and can be divided more accurately than the analog voltage, linearity errors are minimized. The multi-bit analog-to-digital converter, rather than the single bit converter of prior art devices, allows a more accurate result with a lower sample rate. This eases the requirements for decimation filtering in software.

[0025] Sample and Hold

[0026] FIG. 4 is a circuit diagram of an embodiment of the invention illustrating the switch controlling the input to the integrator in the sigma-delta modulator, with the switch being used for a sample and hold circuit. FIG. 4 shows many of the same circuit blocks as FIG. 2, such as analog-to-digital converter 54, feedback digital-to-analog converter 56, switching circuit 58, input resistors 42 and 66, and operational amplifier 44 configured as an integrator with capacitor 46. Only a single stage is shown for simplicity, and it is understood that an additional integrator 53 as in FIG. 2 could be added as well, with a similar switch for a sample and hold for the second integrator.

[0027] FIG. 4 adds a D flip-flop 74 and switching circuit 76. Switch 76 disconnects the input 40 from the input of operational amplifier 44 for a hold operation. When the input is reconnected after the sample has been held, a problem can arise since the voltage at the input can vary dramatically due to the feedback circuit through switch 58 and resistor 66. Since this feedback switches between a positive and negative voltage, a significant variation in the input voltage could occur. For example, the feedback might vary between approximately 0-3 volts, with the input being around 1 volt. This would result in a 1.5 volt swing. Such a swing would cause, upon reconnection to the inverting input of operational amplifier 44, a charge injection into capacitor 46, which is undesirable.

[0028] The present invention avoids such a charge injection by connecting the node 73 to the non-inverting input of operational amplifier 44. This non-inverting input further is connected to a reference voltage. This gives the current which would build up a place to go. The difference in voltage will result in current flow either toward or away from the reference voltage 75. Thus, upon reconnection, there will be minimal charge injection. The result of this structure is that the charge injection from the switch will be essentially constant, to the extent there is any, and it can be canceled out later by processing in a digital domain using a software or firmware program.

[0029] FIG. 5 illustrates certain of the waveforms of the circuit of FIG. 4. The pulse width modified (PWM) signal

on line **76** at the output of digital-to-analog converter **56** is shown first. The arrows signify that the width of the pulse will vary depending upon the signal. Next, the sample/hold signal on line **78** is shown, the non-inverting output of D flip-flop **74**. Finally, the voltage out ( $V_o$ ) signal on line **80** at the output of the integrator of operational amplifier **44** and capacitor **46** is shown. As can be seen, the  $V_o$  signal decays while the PWM signal is high, and increases or integrates while the PWM signal is low as long as the sample/hold signal is high. While the sample/hold signal is low, the  $V_o$  signal is held constant so that it can be sampled. Although illustrated at the same level each time in **FIG. 5**, the levels would vary with the amount of integration and the width of the pulse from the PWM feedback signal.

[**0030**] Multiple Capacitor Sigma-Delta Modulator

[**0031**] **FIG. 6** illustrates a modification of the circuit of **FIG. 4** in which capacitor **46** of **FIG. 4** is replaced by one of four capacitors, **C1**, **C2**, **C3**, and **C4**, which are selected by a switching circuit **82**.

[**0032**] In a typical prior pulse oximeter, two separate integrators would need to be used with two separate signal paths and demodulation in the analog domain, so that the two different integrators could use two different capacitors for the red and IR signals. By instead switching in and out capacitors, a single integrator can be used, and the analog domain demodulation circuitry can be eliminated. Instead, the red and IR signals are time-multiplexed through the same integrator, with different capacitors being switched in for the red and IR signals. In addition, two additional capacitors can be added for the dark period in between the red and IR signals. Since the dark signal can vary depending upon whether it follows the IR signal, or follows the red signal, two different capacitors can be provided to correspond to dark **1** and dark **2** signals. Thus, the present invention allows the demodulation of the signal to be moved into the digital domain and be done by a program in software or firmware, rather than having it done with hardware. This allows the hardware circuitry to be reduced in size by using only a single signal path, saving not only space and cost but also power.

[**0033**] **FIG. 7** illustrates the different signals of **FIG. 6**, with the PWM, sample/hold, and  $V_o$  signals as in **FIG. 5**, plus showing the voltage input ( $V_i$ ) signal on input line **40**.

[**0034**] As the input line varies from IR to dark **1** to red to dark **2**, switching circuit **82** switches between the different capacitors **C1-C4**. The switching is controlled by a signal from the controller, since the controller knows when it switches on and off the red and IR LEDs, and thus can switch the capacitors at the same times.

[**0035**] In one embodiment, the features of **FIGS. 2, 4**, and **6** are combined, providing a two-stage integrator with PWM feedback, a switching circuit for each integrator to function as a sample and hold for the integrators, and multiple capacitors being switched in for each of the integrators. Thus, the present invention allows a single path to be used through the analog hardware circuitry for both red and the IR signals, saving components, cost, circuit size, and power consumption. By moving the demodulation from hardware into the digital domain to be done in software/firmware, there is no need to be concerned about mismatching of the filters for the red and IR signals, since the same filters are

used. Since the accuracy of filtering in hardware is dependent upon component tolerance, using the same signal path allows the use of the same hardware, thus eliminating gain error introduced into one signal but not the other. If the red and IR signals have the same frequency response, the ratio-of-ratios (rat-rat) equation used by the software to calculate oxygen saturation will cancel out that error. Also, doing the demodulation in software allows a more sophisticated demodulation scheme to be used than what could be done easily in hardware.

[**0036**] As will be understood by those with skill in the art, the present invention may be embodied in other specific forms without departing from the essential characteristics thereof. For example, a third order modulator could be used, or a higher or lower resolution multi-bit analog-to-digital converter. Innumerable other variations could be made in the circuitry without departing from the essential characteristics of the invention. Accordingly, the foregoing description is intended to be illustrative of, but not limiting of, the scope of the invention which is set forth in the following claims.

What is claimed is:

1. An oximeter apparatus comprising:

- a sigma-delta modulator having an input coupled to receive an analog sensor signal;
- a first switching circuit, coupled to said input, for switching between connecting first and second reference voltages to said input; and
- a feedback circuit, coupled to an output of said sigma-delta modulator, for controlling the switching between said first and second reference voltages by said switching circuit.

2. The oximeter apparatus of claim 1 further comprising:

- a multiple bit analog-to-digital converter coupled to said output of said sigma-delta modulator to provide a digital output; and
- said feedback circuit including a digital-to-analog converter having an input coupled to said digital output, and an output coupled to said switching circuit.

3. The oximeter apparatus of claim 1 further comprising:

- a resistor coupled between said switching circuit and said input of said sigma-delta modulator.

4. The oximeter apparatus of claim 1 wherein said sigma-delta modulator comprises first and second integrators, and further comprising:

- a second switching circuit coupled to an input of said second integrator and controlled by said feedback circuit, for switching to said second voltage reference when said first switching circuit connects to said first voltage reference, and switching to said first voltage reference when said first switching circuit switches to said second voltage reference.

5. The oximeter apparatus of claim 1 further comprising:

- wherein said sigma-delta modulator includes an operational amplifier configured as an integrator;
- a second switching circuit configured to function as a sample and hold by alternately couple said input to inverting and non-inverting inputs of said operational amplifier; and

a control circuit, coupled to said feedback circuit, for controlling the switching of said second switching circuit.

6. The oximeter apparatus of claim 5 wherein said control circuit comprises a flip-flop.

7. The oximeter apparatus of claim 1 wherein said sigma-delta modulator includes an integrator, and further comprising:

at least first and second capacitors; and

a capacitor switching circuit for connecting said first capacitor into said integrator upon receipt of a first sensor signal, and connecting said second capacitor into said integrator upon receipt of a second sensor signal.

8. The oximeter apparatus of claim 7 wherein said first sensor signal is a red signal and said second sensor signal is an infrared signal.

9. The oximeter apparatus of claim 8 further comprising a third capacitor for connecting into said integrator upon receipt of a dark signal between said red and infrared signals.

10. The oximeter apparatus of claim 9 further comprising a fourth capacitor for connecting into said integrator for a second dark signal between said infrared signal and said red signal.

11. The oximeter apparatus of claim 1 wherein a single signal path through said sigma-delta modulator is used for both a red and an infrared signal.

12. The oximeter apparatus of claim 11 further comprising:

a multiple bit analog-to-digital converter coupled to said output of said sigma-delta modulator to provide a digital output; and

a memory containing a program for demodulating said digital output into red and infrared digital signals.

13. An oximeter apparatus comprising:

a sigma-delta modulator having an input coupled to receive an analog sensor signal;

a first switching circuit, coupled to said input, for switching between connecting first and second reference voltages to said input;

a multiple bit analog-to-digital converter coupled to said output of said sigma-delta modulator to provide a digital output; and

a feedback circuit, coupled to an output of said multiple bit analog-to-digital converter, for controlling the switching between said first and second reference voltages by said switching circuit, said feedback circuit providing a pulse width modulated signal to said switching circuit; and

a resistor coupled between said switching circuit and said input of said sigma-delta modulator.

14. An oximeter apparatus comprising:

a sigma-delta modulator having an input coupled to receive an analog sensor signal, wherein said sigma-delta modulator includes an operational amplifier configured as an integrator;

a switching circuit configured to function as a sample and hold by alternately couple said input to inverting and non-inverting inputs of said operational amplifier;

a feedback circuit coupled between an output and said input of said sigma-delta modulator; and

a control circuit, coupled to said feedback circuit, for controlling the switching of said switching circuit.

15. An oximeter apparatus comprising:

a sigma-delta modulator having an input coupled to receive an analog sensor signal, wherein said sigma-delta modulator includes an integrator;

at least first and second capacitors; and

a capacitor switching circuit for connecting said first capacitor into said integrator upon receipt of a first sensor signal, and connecting said second capacitor into said integrator upon receipt of a second sensor signal.

16. The oximeter apparatus of claim 16 wherein said first sensor signal is a red signal and said second sensor signal is an infrared signal.

17. The oximeter apparatus of claim 17 further comprising a third capacitor for connecting into said integrator upon receipt of a dark signal between said red and infrared signals.

18. The oximeter apparatus of claim 18 further comprising a fourth capacitor for connecting into said integrator for a second dark signal between said infrared signal and said red signal.

19. An oximeter apparatus comprising:

a sigma-delta modulator having an input coupled to receive an analog sensor signal;

a multiple bit analog-to-digital converter coupled to said output of said sigma-delta modulator to provide a digital output;

a feedback circuit, coupled between an output of said analog-to-digital converter and said input of said sigma-delta modulator; and

a memory containing a program for demodulating said digital output into red and infrared digital signals

wherein a single signal path through said sigma-delta modulator is used for modulated red and infrared signals.

\* \* \* \* \*

专利名称(译)	具有sigma-delta调制的多位ADC		
公开(公告)号	<a href="#">US20050184895A1</a>	公开(公告)日	2005-08-25
申请号	US10/787542	申请日	2004-02-25
[标]申请(专利权)人(译)	内尔科尔普里坦贝内特公司		
申请(专利权)人(译)	NELLCOR PURITAN BENNETT INC.		
当前申请(专利权)人(译)	COVIDIEN LP		
[标]发明人	PETERSEN ETHAN SHEA WILLIAM CHEW BRADFORD B		
发明人	PETERSEN, ETHAN SHEA, WILLIAM CHEW, BRADFORD B.		
IPC分类号	A61B5/00 H03M3/04 H03M3/00		
CPC分类号	A61B5/14551 A61B5/7228 H03M3/464 H03M3/456 H03M3/424		
其他公开文献	US7142142		
外部链接	<a href="#">Espacenet</a> <a href="#">USPTO</a>		

摘要(译)

血氧计使用sigma-delta调制器和带有PWM反馈的多位ADC，可实现高精度多位转换。解调是在软件中完成的，因此红色和红外只需要一个硬件路径。多个电容器切换到Σ-Δ调制器中的积分器，具有用于红色，红外和暗信号的不同电容器，从而能够使用单个硬件路径。在Σ-Δ调制器的输入端的开关电路用作采样和保持，由PWM反馈控制。

