



US 20050165324A1

(19) **United States**

(12) **Patent Application Publication**

**Receveur et al.**

(10) **Pub. No.: US 2005/0165324 A1**

(43) **Pub. Date: Jul. 28, 2005**

(54) **SYSTEM AND METHOD FOR USING SENSORS TO IDENTIFY AN ANATOMICAL POSITION**

**Related U.S. Application Data**

(60) Provisional application No. 60/539,202, filed on Jan. 26, 2004.

(76) Inventors: **Rogier Receveur**, Maastricht (NL); **Vincent Larik**, Kerkrade (NL); **Ron Van Der Kruk**, Bunde (NL); **Victor Duysens**, Grevenbicht (NL); **Richard P.M. Houben**, Lanaken (BE); **Nicolaas M. Lokhoff**, Kerkrade (NL); **John C.M.J. Feron**, Sittard (NL)

**Publication Classification**

(51) **Int. Cl.<sup>7</sup>** ..... **A61B 5/00**; **A61B 5/02**  
(52) **U.S. Cl.** ..... **600/549**; **600/485**

(57) **ABSTRACT**

A sensor is provided on a lead and senses various physical parameters that are indicative of a desired anatomical target, such as the coronary sinus. The data from the sensor is used to navigate to the anatomical target and/or confirm that the anatomical target has been reached. In one embodiment, the sensor is a temperature sensor and increased temperature values in and around the coronary sinus are used for navigational purposes.

Correspondence Address:  
**MEDTRONIC, INC.**  
**710 MEDTRONIC PARKWAY NE**  
**MS-LC340**  
**MINNEAPOLIS, MN 55432-5604 (US)**

(21) Appl. No.: **10/781,111**

(22) Filed: **Feb. 18, 2004**

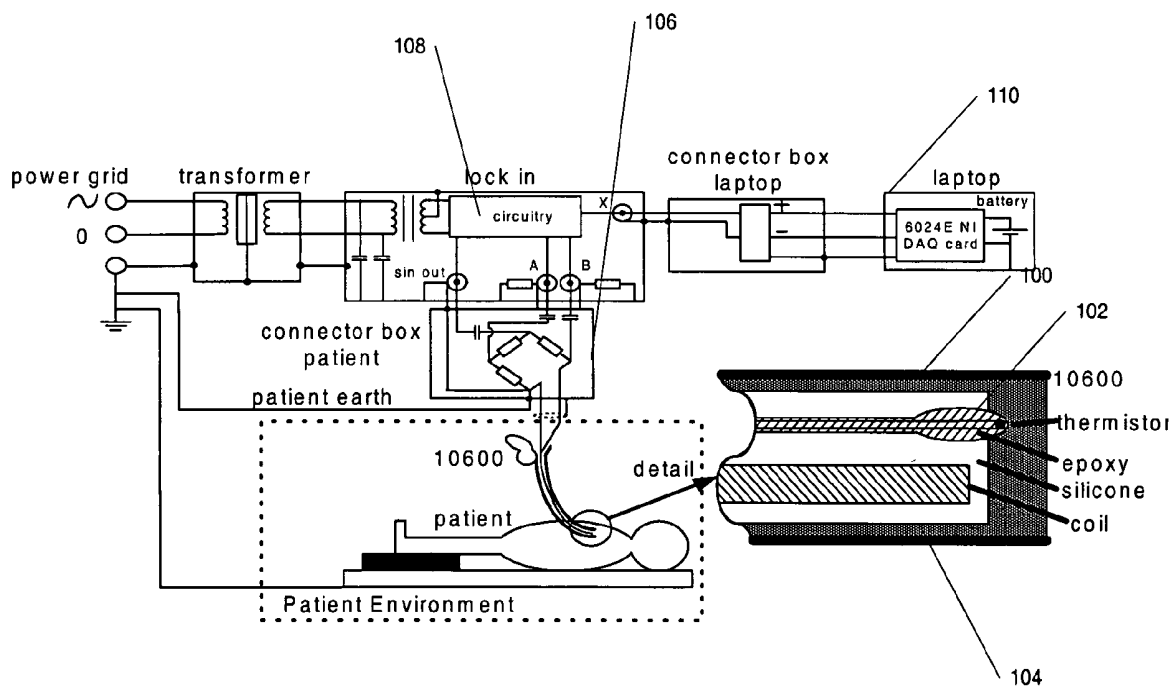

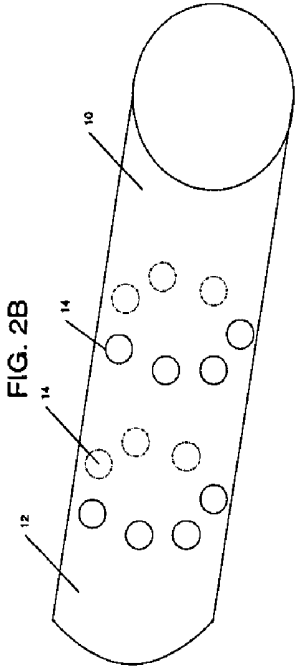
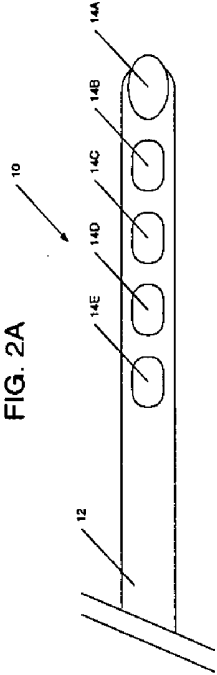
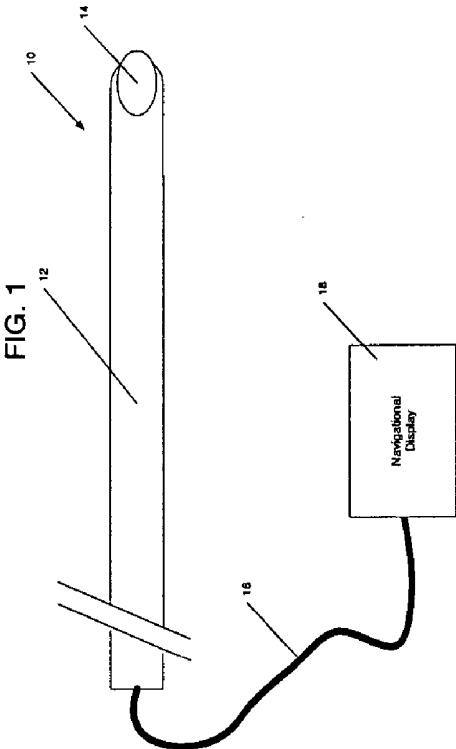

FIG. 3

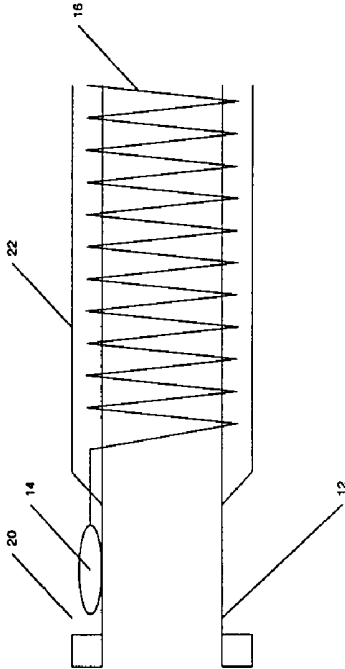
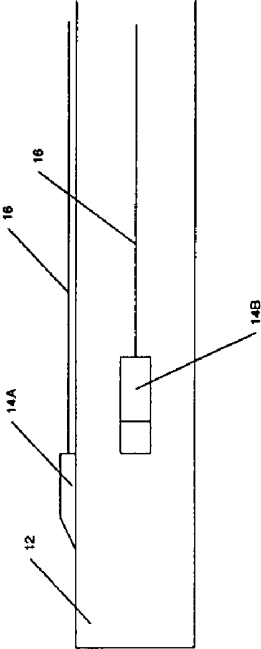

FIG. 4



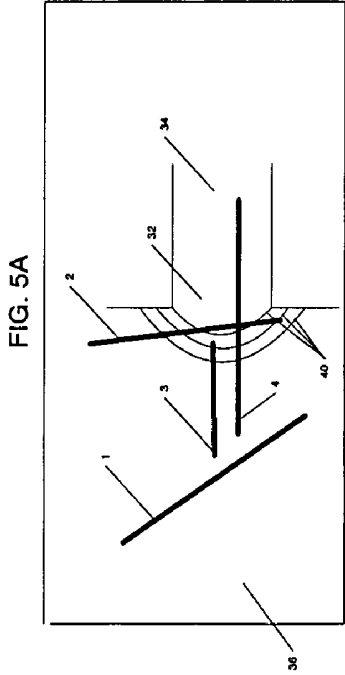

FIG. 5C

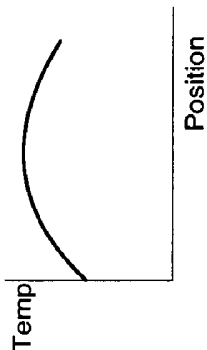

FIG. 5B

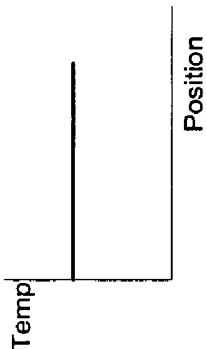

FIG. 5E

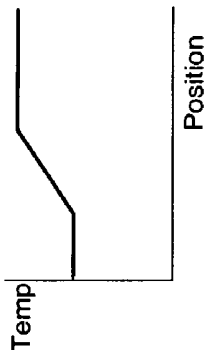

FIG. 5D

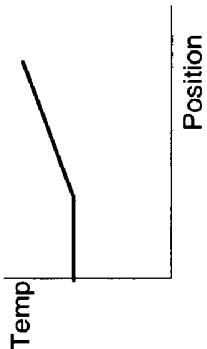

FIG. 6

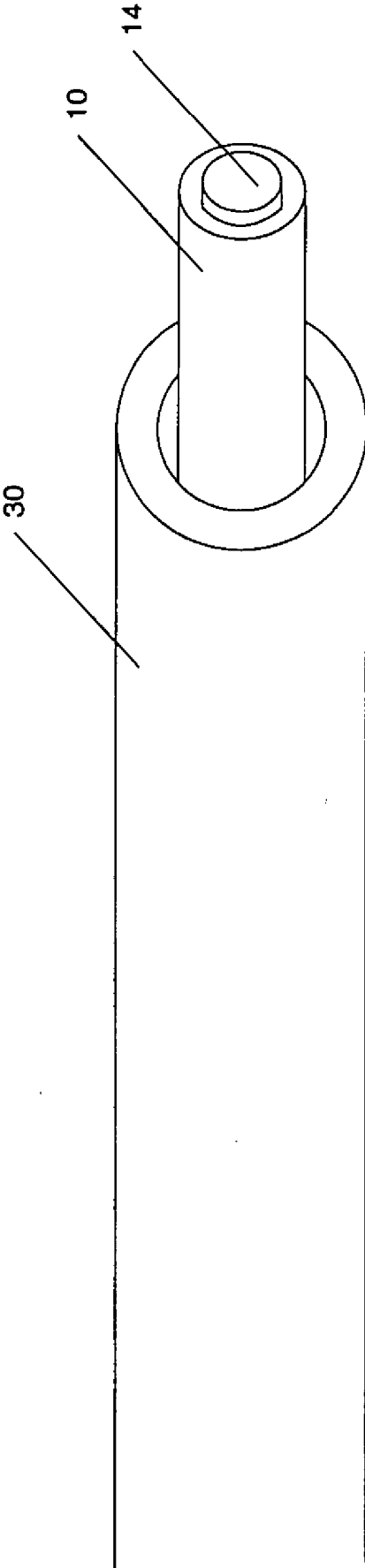

FIG. 7

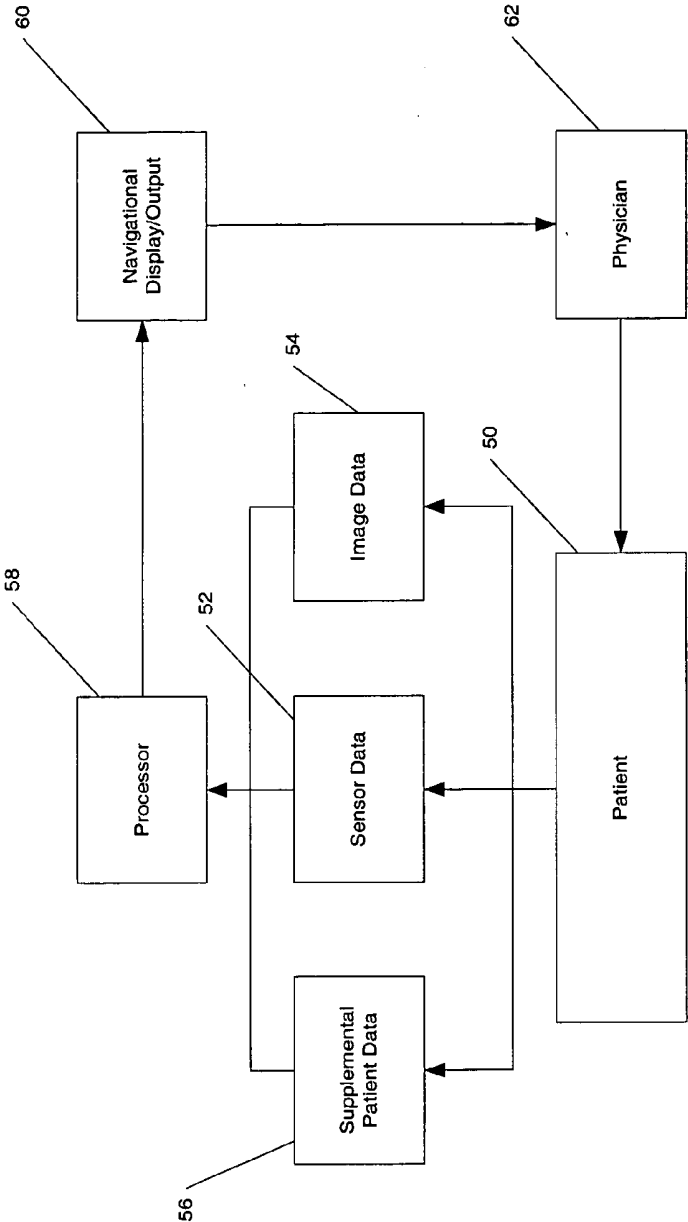

FIG. 8

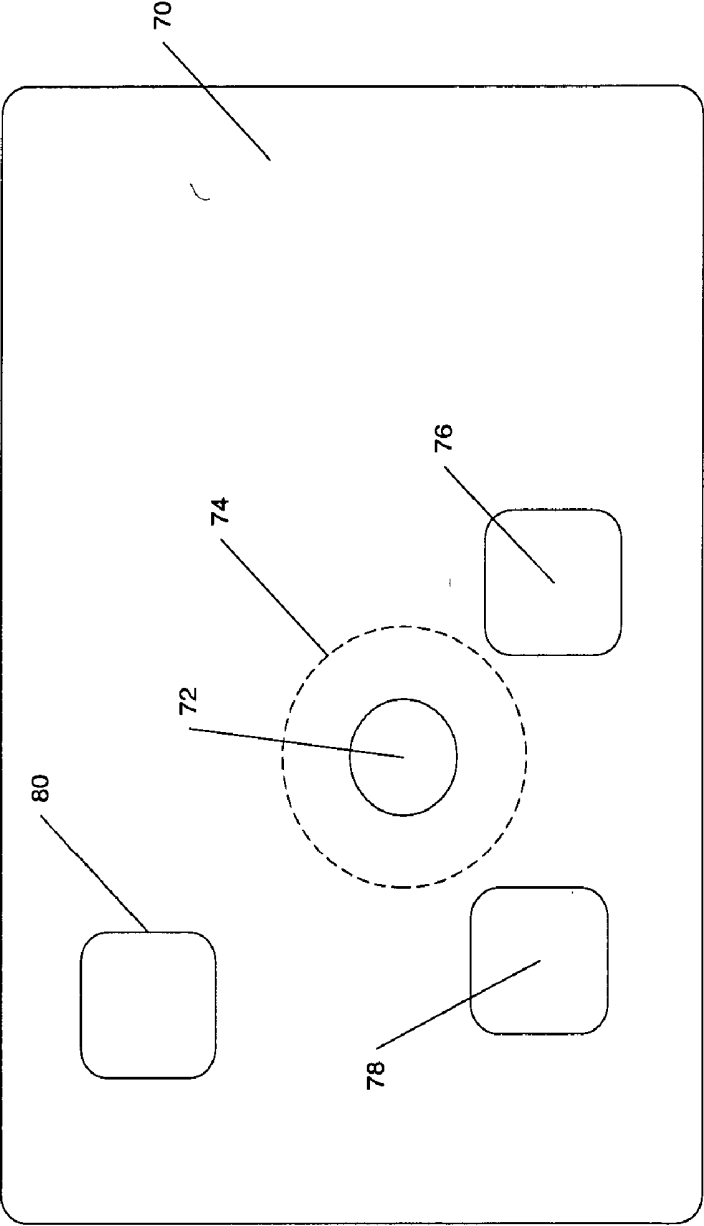

FIG. 9

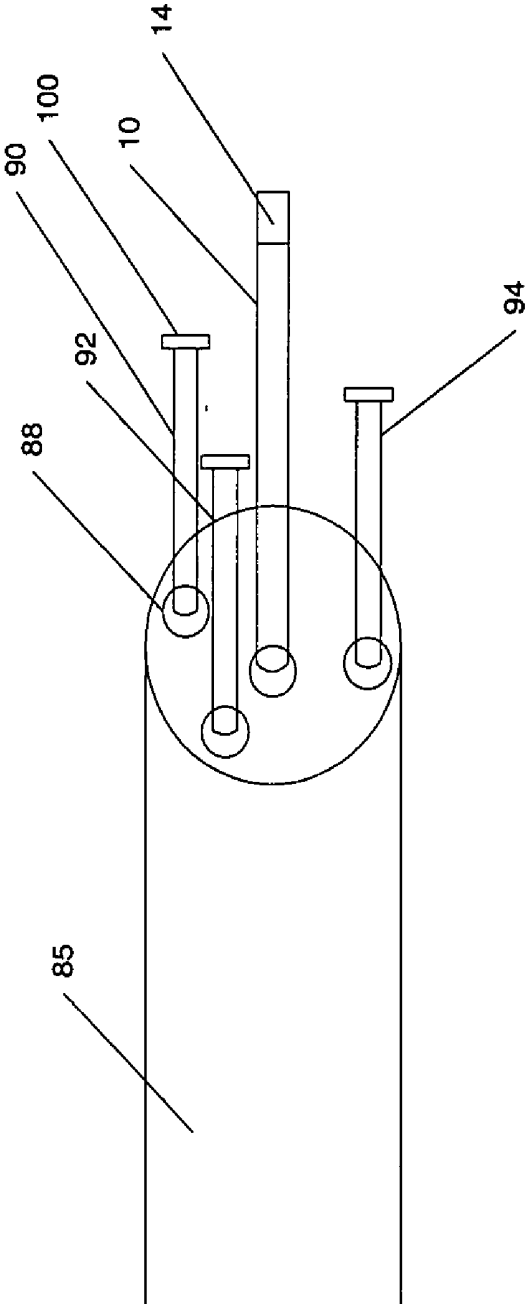

FIG. 10

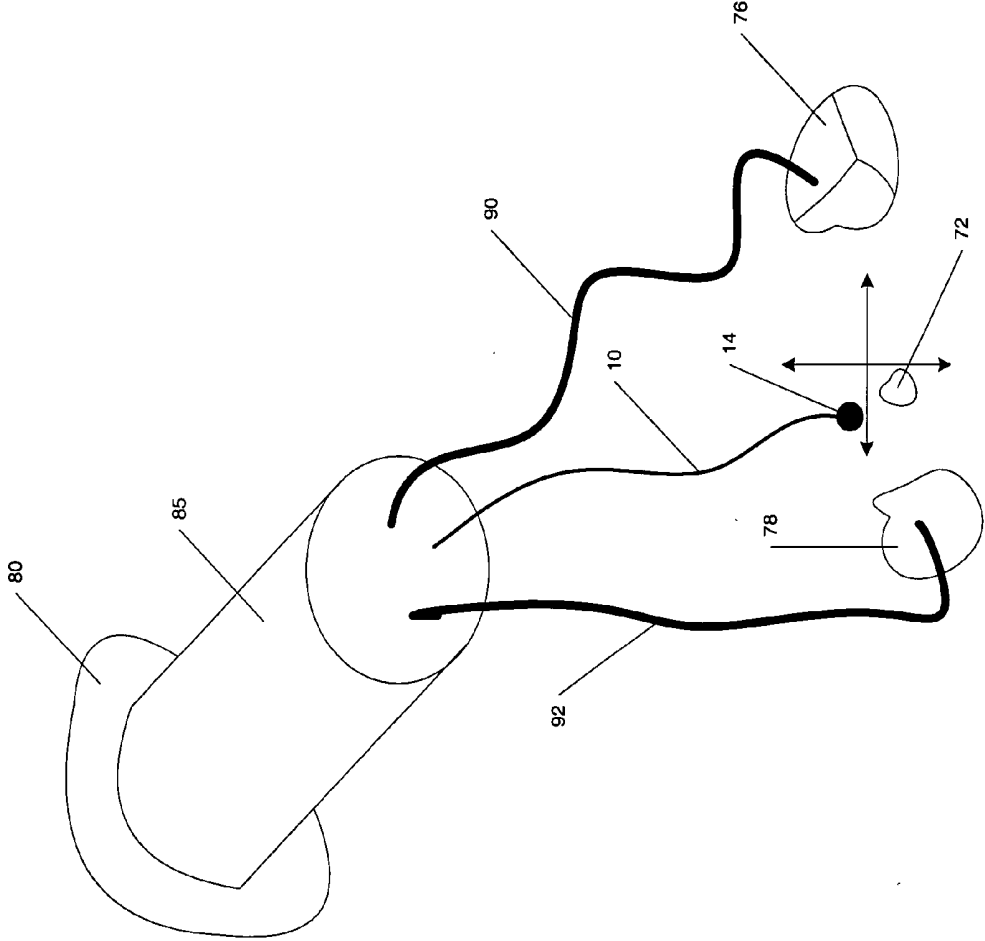
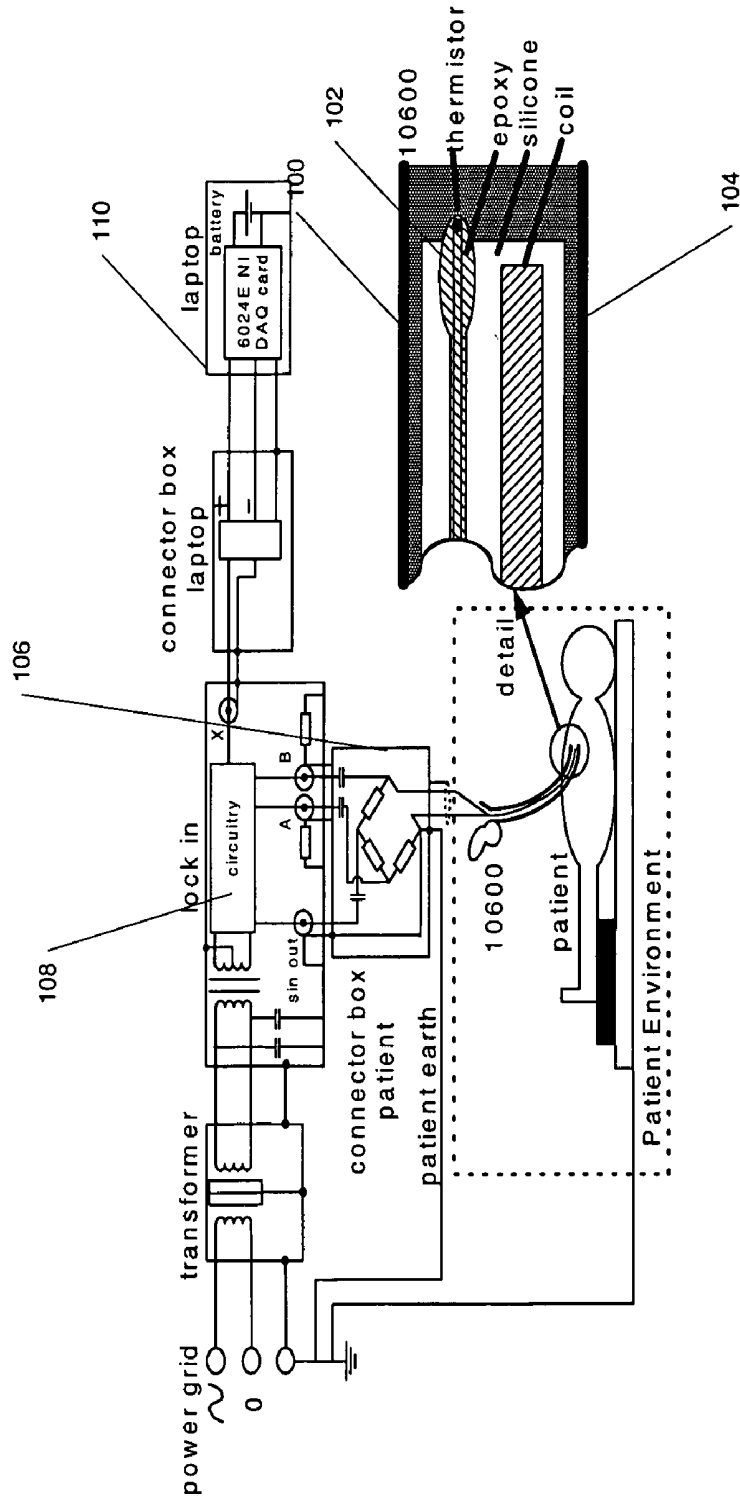

FIG. 11



## SYSTEM AND METHOD FOR USING SENSORS TO IDENTIFY AN ANATOMICAL POSITION

### FIELD OF THE INVENTION

[0001] The present invention relates to implantable medical devices. More specifically, the present invention relates to a system and method for locating a specific anatomical position.

### DESCRIPTION OF THE RELATED ART

[0002] Various medical devices exist that utilize a lead to sense signals from or deliver electrical stimulation to cardiac tissue. For example, cardiac pacemakers often utilize a single lead having a distal tip disposed within the right atrium or right ventricle of the heart to sense and pace. Dual chamber devices have a lead in both the ventricle and the atrium and are quite commonly used. Implanting a lead within either right-sided chamber is relatively straightforward and typically presents little complication for a skilled practitioner.

[0003] More recently, a benefit has been recognized in pacing, sensing, stimulating or otherwise having communication with the left side of the heart. In general, leads are typically not implanted within the left atrium or left ventricle as oxygenated blood flows from the left side to the remainder of the body. As such, left sided lead placement has undertaken several alternative approaches.

[0004] An epicardial lead may be affixed to an external portion of the heart, i.e., the pericardium, at an appropriate location on the left side of the heart. While current techniques are being improved, the difficulty with the use of such epicardial leads is their guidance and manipulation from the implant site, through the chest cavity to the heart, and their affixation. The procedure is at least different, if not more complicated, than standard venous implantation for, e.g., right sided leads.

[0005] As such, a venous implantation technique is available and is presently the most commonly used technique for left-sided lead implantations. In summary, a lead is advanced into the right atrium and caused to enter the coronary sinus. The lead is then manipulated through the cardiac vein until it is properly situated against the exterior wall of the left ventricle or left atrium. Because of this disposition within a relatively narrow vein, the lead is often affixed by relying on a wedging action of a biased portion of the lead, though other affixation techniques may be utilized.

[0006] One of the more challenging aspects of such an implantation is initially inserting the lead or the guiding mechanism (e.g., catheter, stylet, guidewire) into the ostium of the coronary sinus. In fact, this step often accounts for a great deal of the total implantation time. In addition, the variability in this difficult step between patients leads to great variability in total implant time across patients. In some difficult cases, the coronary sinus cannot be located and the procedure is abandoned in lieu of an epicardial lead placement.

[0007] The difficulty in inserting the lead or guiding mechanism into the coronary sinus arises from several different factors. Entry into the right atrium is, as mentioned relatively straight forward. For example, following the superior vena cava will lead directly into the right atrium.

However, the right atrium is a relatively large (with respect to the coronary sinus), chamber that is in rhythmic motion. For this reason alone, navigation, especially via remote manipulation, is difficult. In addition, more significant anatomical structures, such as the tricuspid valve or the inferior vena cava are more easily detected and in that sense, provide obstacles to manipulating the device to find the coronary sinus. The position, configuration, and orientation of the coronary sinus often make it somewhat occluded and thus, more difficult to find. Finally, the angle of entry is often not conducive to easy remote manipulation. Wide variation in patient anatomy may greatly affect the scope of any or all of these issues.

[0008] The implantation procedure often relies on a fluoroscope to permit the practitioner to view certain anatomical features and the leads current position with respect to those features. Fluoroscopy does not illustrate soft tissue very well and provides virtually no guidance with respect to locating the coronary sinus. Thus, the practitioner is working almost entirely by feel.

[0009] Thus, one of the major obstacles in left sided lead implantations, or other left sided procedures, is the initial location of the coronary sinus and the insertion of the lead, guiding mechanism, or other tool therethrough.

### BRIEF DESCRIPTION OF THE DRAWINGS

[0010] FIG. 1 is a schematic illustration of a lead with a sensor coupled to a navigational display.

[0011] FIGS. 2A-2B are schematic illustrations of a lead having a plurality of sensors.

[0012] FIG. 3 is a schematic illustration of a sensor coupled with a lead.

[0013] FIG. 4 is a schematic illustration of a plurality of sensors coupled with a lead.

[0014] FIG. 5A illustrates sensor paths proximate the coronary sinus.

[0015] FIGS. 5B-5E are graphs relating temperature to position for the sensor paths of FIG. 5A.

[0016] FIG. 6 is a schematic illustration of a lead having a sensor, disposed within a catheter.

[0017] FIG. 7 is a block diagram of a system for obtaining an processing sensor data.

[0018] FIG. 8 is a schematic diagram illustrating anatomical positions within the right atrium.

[0019] FIG. 9 is a schematic diagram of a catheter and a plurality of anchoring members.

[0020] FIG. 10 is a schematic diagram of the catheter of FIG. 9 deployed within the right atrium.

[0021] FIG. 11 is a schematic diagram illustrating one embodiment of a device having thermistor for navigating through cardiac anatomy.

### DETAILED DESCRIPTION

[0022] The present invention, in one embodiment is a system and method that provides for the guidance of a device to the ostium of the coronary sinus and/or provides confirmation that the device is located within the coronary

sinus. The device is a lead that is being implanted or is a guidance device, such as a catheter, stylet, guidewire or the like that will facilitate the implantation of a lead. The device could also be various other tools such as an ablation electrode or various sensors that are used on a temporary or permanent basis.

[0023] The coronary sinus provides an entryway for return blood flow into the right atrium and, as previously indicated, is relatively small with respect to the right atrium. As such, the return blood flow generates a number of physical characteristics. For example, there is a temperature variance between the blood within the coronary sinus and that within the right atrium on the order of about 1° C. More precisely, the temperature differential is usually on the order of about 0.2° C. As such, there is a temperature gradient about the ostium of the coronary sinus. In addition, the pulsatile blood flow generates certain pressure characteristics as well as turbulent flow. The oxygen and/or carbon dioxide levels of the return blood from the coronary sinus are distinguishable from that present in the right atrium. In summary, the nature of the return blood flow from the coronary sinus presents certain detectable physical indicia.

[0024] FIG. 1 illustrates a lead 10 having a sensor 14 disposed at or near a distal end of the lead 10. The lead 10 has a lead body 12 that carries the sensor 14 and can be manipulated for movement and steerability within the cardiac anatomy. The lead 10 may include various pull wires, a stylet may be disposed within the lead 10, the lead 10 may pass over a guidewire, or the lead may be disposed within a catheter or incorporate various other known manipulation devices. In its most basic sense and as used herein, lead 10 is illustrative of any device that can be passed into and guided within the right atrium and then detect and/or enter the coronary sinus, such as, for example, a sensing/pacing/defibrillation lead, a catheter, a stylet, a guidewire, or various other medical delivery or surgical instruments. Depending upon the particular device employed, other elements will be present (e.g., sense/pace electrodes) that are omitted here for clarity.

[0025] Lead 10 is communicatively coupled with a navigation control display 18 via electrical connections 16. Navigation control display 18 takes data acquired from the sensor 14 and displays or otherwise presents the data (e.g., audible representations). Alternatively, or in addition thereto, navigation control display 18 processes the data and then displays or presents guidance information.

[0026] The sensor 14 may sense any criteria useful for locating the coronary sinus and/or confirming that the sensor 14 is disposed within the coronary sinus. In one embodiment, the sensor 14 is a temperature sensor. In another embodiment, the sensor 14 is for example, a pressure sensor, an oxygen sensor, a chemical sensor (e.g., lactate), senses PH balance, is a velocity sensor that senses flow, is an ultrasound sensor (with or without Doppler capability), or is an optical sensor. For any given parameter, multiple sensor options exist. Pressure, for example, may be sensed via compression of a calibrated element, a piezo-electric sensor, or an optical sensor. Likewise, blood oxygen may be sensed via an optical sensor or a chemical sensor that measures direct levels or derivatives.

[0027] As illustrated in FIGS. 2A-2B, the lead 10 may include a plurality of sensors 14A-14E, that can be arranged

in any desired configuration. Such a combination of sensors provide an array that facilitate the sensing of, for example, a temperature gradient. Alternatively, different types of sensors may be employed in concert to detect any number and type of indicia. For example, both pressure and temperature may be sensed simultaneously.

[0028] FIGS. 3 and 4 illustrate various ways of coupling the sensor 14 to the lead body 12. For example, external shielding 22 is disposed about the lead body 12 that encases the electrical communication means 16. The electrical communication means 16 includes wires, cables, fiber optics, or any suitable medium for transmitting data obtained from the sensor 14. The sensor 14 is exposed through an opening 20 within the external shielding 22. The external shielding is disposed circumferentially about the lead body 12 in a coaxial arrangement or may form a smaller, linear tubular arrangement disposed on an outer surface of the lead body 12.

[0029] FIG. 4 illustrates an embodiment wherein the sensor 14 is affixed to an external portion of the lead body 12 and the electrical communication means 16 includes one or more wires that are axially aligned with the lead body 12. Depending upon the device employed, the sensor 14 may depend externally from or reside within the distal end of the lead 10, reside within an interior portion of the lead 10, depend from any exterior portion of the lead, or be partially exposed through some portion of the lead 10. In addition, the sensor 14 may be selectively deployed through a lumen within the lead 10, a catheter 30 (FIG. 6) or a similar device. The sensor 14 will be positioned and selectively covered or exposed depending upon the nature of the parameter that is sensed. For example, a mechanical pressure sensor will have some surface directly or indirectly in physical contact with the surrounding fluid medium, whereas an ultrasound sensor could be disposed entirely within the lead 10 and still provide data.

[0030] In use, the lead 10 is guided into the right atrium and the sensor 14 provides data to an external device. This data is used by the physician to manipulate and guide the lead 10 to the coronary sinus and/or confirm that the lead 10 is within the coronary sinus. Of course, the present invention could be used to navigate to any other desired anatomical location, based on appropriate sensed parameters.

[0031] In one embodiment, the sensor 14 is a temperature sensor. The temperature sensor 14 is a thermocouple, a thermistor, or any other temperature sensing device at least having sufficient ability to distinguish temperature variations within a range that is on the order of about 0.2° C., as this represents the temperature gradient about the ostium of the coronary sinus. While accurate calibration between sensed and actual temperature values is appropriate and may, in some embodiments, provide additional value, accurate sensing of temperature differentials provides sufficient basis for navigation. The temperature increase between the ostium as compared to the averaged right atrium may be used, rather than specific temperature values, in certain embodiments.

[0032] In one embodiment, the temperature sensor 14 is sufficiently sensitive and provides a sufficient signal to noise ratio to accurately detect temperature variations on the order 0.01° C. This temperature sensor 14 has a rapid response time of 50 milliseconds or better so as to provide tracking information relating to movement of the sensor 14. Finally,

the temperature sensor 14 is stable so that indicated temperature variations reliably result from actual temperature differential and not from a drift in the sensor characteristics.

[0033] FIG. 5A is a schematic illustration of the ostium of the coronary sinus 32, with the cardiac vein 34 flowing into the right atrium 36. Various temperature bands 40 are illustrated having a common temperature, with temperature generally varying as a function of distance from the ostium 32. As the blood exits the ostium 32, it has a given average temperature. As this blood mixes with that of the right atrium, the temperature averages to the level normal within the right atrium; hence, the temperature of the blood from the coronary sinus 32 decreases as a function of distance.

[0034] Various potential paths taken by the sensor 14 when moved within the right atrium are illustrated as solid lines 1-4. Path 1 causes the sensor 14 to remain sufficiently distant from the ostium 32 so as to only detect blood temperatures in the averaged range; that is, the average temperature of blood within the right atrium. FIG. 5B is a graph of temperature versus position corresponding to path 1. As illustrated, the graph indicates a relatively constant temperature and the indication would be that the sensor 14 is not proximate to the ostium 32.

[0035] Path 2 represents movement of the sensor 14 from the right atrium past the ostium 32. The resultant temperature graph is illustrated in FIG. 5C. As shown, the temperature is initially at the averaged value, then increases until the sensor 14 is actually again moving away from the ostium 32, thus a decrease in temperature results. Path 3 represents movement of the sensor from the average temperature region directly towards the ostium 32. The temperature graph of FIG. 5D illustrates this path. The temperature is initially flat or constant and representative of the average temperature of the right atrium. As the sensor 14 approaches the ostium 32, temperature rises with a linear relationship that is proportional to distance. Path 3 is illustrated as stopping prior to reaching the ostium 32; thus, the temperature graph terminates at a higher temperature value. Path 4 is similar to path 3 but proceeds into the coronary sinus 32. This path is represented in the temperature graph of FIG. 5E. Again, the temperature remains flat or constant until the sensor 14 approaches the ostium 32. As the sensor 14 approaches the ostium of the coronary sinus 32, the temperature rises linearly, proportional to distance. When the sensor 14 enters the ostium 32, the temperature is constant and is represented as such. Of course, this temperature value is elevated from that of the right atrium 36.

[0036] FIGS. 5A-5E represent one embodiment wherein sensor data, such as temperature data, may be used to map a portion of the right atrium 36 and/or navigate within the right atrium 36. Other physical parameters such as oxygen content, pressure, velocity, or the like may be used in a similar manner. The raw data itself may provide some useful information to the operator of the device. For example, in one embodiment the sensor 14 is used simply to confirm that the associated device, e.g., lead 10 is in fact located within the coronary sinus 32. Temperature values, or other raw data, may be used to quickly make such a conclusion. That is, the average temperature of the right atrium will be measured and hence known. The current temperature value from the sensor 14 is monitored and if elevated by a sufficient amount, e.g., about 1° C., provides a confirmation that the sensor is

no longer in the right atrium. Used in conjunction with known techniques, this may establish that the sensor 14 is in the coronary sinus. Of course, other temperature differentials exist with respect to the right atrium, such as within the inferior vena cava. Therefore, the other known techniques, such as fluoroscopy establish that the sensor 14 is not in another, easily identified higher temperature area therefore establishing that the higher temperature data indicates that the sensor 14 is in the coronary sinus. In summary, the temperature values provide a confirmation that the device is within the coronary sinus.

[0037] More directional information is gathered by providing a plurality of sensors 14 that are arranged circumferentially about the lead 10, as illustrated in FIG. 2B. With such a configuration, the various sensors 14 sense in different directions. Thus, by knowing the relative positions and orientations of the various sensors 14, their varying output will provide a directional component to the gathered temperature data.

[0038] The representations provided in FIGS. 5B-5E apply to configurations having a single temperature sensor as well as multiple sensors. That is, a single sensor 14 moved along the trajectories indicated in FIG. 5A, will in fact provide the indicated results. However, with a single temperature sensor 14, it may be more difficult to determine a course of direction based upon any given data point. With multiple, directionally distinct sensors 14, each provides the above described information with the addition of a directional component. Thus, a predictive path can be plotted. For example, consider a lead 10 having multiple sensors 14 arranged in different directions, e.g., circumferentially as illustrated in FIG. 2B. If the lead 10 positioned so that is represents path 2 of FIG. 5A, then sensors 14 facing the coronary sinus 32 would sense a higher temperature than those facing the center of the right atrium.

[0039] While such raw data provides value in certain embodiments, the present invention also provides for computational analysis of this raw data to generate navigational information and/or provide for confirmation of entry. For example, by recording temperature versus position, as represented in FIGS. 5B-5E, the path and relative position of the sensor 14 can be calculated. Once the raw data is processed, the resulting navigational data may be used in a number of ways. For example, a graphical model or map is illustrated on a screen with a representation of the current sensor 14 position and the mapped anatomical features that are known, such as the coronary sinus 32. The physician then navigates based on this generated map. Alternatively, or in addition to the graphical mapping features, audible commands can be generated based on the processed data. For example, commands such as "advance," "retract," "rotate X degrees," etc. are generated by the processor. More tonal representations of the raw data may also be produced. For example, a tone is generated corresponding to the sensed temperature; as temperature increases, the frequency of the tone is increased. Thus, the physician is able to discern the relative position of the sensor 14 based on the tone or generated commands, without requiring visual confirmation of the navigational data.

[0040] In one embodiment, the navigational aides are used in concert with existing medical and sensory equipment to aide the physician. FIG. 7 is a schematic illustration of such

a system. The patient **50** has an appropriate device, such as lead **10**, equipped with one or more sensors **14** to sense selected parameters, such as temperature. This sensor data **52** is output to a processor **58**. In addition, imaging data **54** is also gathered from the patient **54**. This imaging data may take any form such as MRI, fluoroscopy, CAT scans, PET scans or the like. Such imaging data may be live or current, e.g., fluoroscopy, or may have been previously captured.

[0041] The processor **58** takes the sensor data **52**, and as previously discussed, generates the appropriate navigational information that is then displayed on or broadcast from a navigational display **60**. The navigational display **60** is a display screen such as for example a CRT or LCD. This display **60** is viewed by the physician **62** and allows for manipulation of the lead **10** within the patient **50** in order to find, enter, and/or confirm entry into the coronary sinus.

[0042] The navigational display **60**, in one embodiment, displays only information derived by the processor from the sensor data **52**. In another embodiment, the derived information is correlated with image data **54** and a composite is generated. For example, current positional data from the sensor **14** and/or an identified position of the coronary sinus are superimposed or digitally combined on a given image or image feed. Thus, the normally transparent soft tissue of the coronary sinus may be represented on the image based on the processed navigational data. The particular technique used to combine the sensor data **52** and the image data **54** will vary depending upon the types of each. For example, digitally created navigational data is superimposed over an analog image source or the image data **54** is digitally captured and manipulated to form a composite with the sensor data **52**.

[0043] Various other physical parameters may have an affect on the data sensed by sensor **14**. For example, when sensing temperature the patient's respiration and cardiac cycle cyclically affect the temperature. Thus, supplemental patient data **56** is gathered and utilized by the processor **58** to generate the navigational information. The supplemental patient data **58** includes, for example, EEG, EKG, blood pressure, respiration rate, tidal volume, patient position/orientation, ambient temperature, patient temperature, drug/pharmacology data (type, rate, dosage, etc.), implant data (e.g., if already in place), or other parameters that would affect the sensed data **52**.

[0044] The processor **58** takes the various data available to provide a useful navigational result to the physician **62**. The navigational display **60** provides meaningful visual and/or audio output that assists the physician in navigating a device, such as lead **10**, within the anatomy of the patient. For example, the navigation display **60** assists the physician **62** in finding and/or confirming entry into the coronary sinus. As previously explained, the sensed data **52** indicates that the device is within the coronary sinus, however such data could be the result of having the device in another anatomical feature, e.g., the inferior vena cava. The processor **58** correlates the other data to effectively rule out such options.

[0045] The present invention, in various embodiments, provides for the confirmation that the lead **10** has entered the coronary sinus. This is a valuable data point for the physician as it is often very difficult to make this determination during an implantation or other type of procedure. Expanding beyond confirmation, various embodiments provide

navigation aides to assist the physician in finding the coronary sinus. As explained, temperature gradients exist about the ostium that are detectable. Other parameters such as pressure, oxygen content, etc. also serve to distinguish the ostium from the remainder of the right atrium.

[0046] The particular parameter selected determines the approximate range of usefulness for navigation purposes. For example, easily measurable temperature variations are typically detectable at a distance of about 1 cm from the ostium. Thus, to rely on temperature data alone for navigation, the sensor **14** must be relatively close to ostium to then identify and navigate to the coronary sinus. Providing more accurate sensors or providing for sensors that sense a given parameter from some distance increases the useful range.

[0047] As previously explained, the lead **10** may be equipped with a plurality of sensors **14** (FIG. 2). Thus, as the lead **10** is manipulated to search for the coronary sinus, one or more of these sensors will likely move within the practical distance required for navigational purposes. In an alternative embodiment, sensors **14** of different types are employed. For example, flow characteristics, pressure, or chemical levels, may be monitored over a greater distance to determine a proper area and once so identified, the temperature data, is used to complete the navigation.

[0048] In another embodiment, the present invention is utilized to determine an appropriate area to search, search for and identify the coronary sinus, and then navigate into the coronary sinus. FIG. 8 is a schematic, highly conceptualized two dimensional representation of a portion of the right atrium **70**. The coronary sinus **72** and a target area **74** are illustrated as the desired end point and search area. The inferior vena cava **78**, tricuspid valve **76**, and superior vena cava **80** are also illustrated. While individual anatomy varies widely from patient to patient, certain anatomical features are generally similarly situated. For example, the coronary sinus **72** is typically disposed within an area between the inferior vena cava **78** and the tricuspid valve **76**, both of which have a known proximal relationship with the superior vena cava **80**.

[0049] Thus, to ultimately locate the coronary sinus **72**, one or more of these more easily identifiable anatomical features are first located to define the target area **74**. Once the target area **74** is so identified, the physician has a general idea where the coronary sinus **72** is and uses the above described techniques to then locate the coronary sinus **72**.

[0050] FIG. 9 illustrates a catheter **85** that includes a plurality of lumens **88**. Anchoring devices **90**, **92**, and **94** are each deployable through a given lumen **88**. The anchoring devices **90**, **92**, and **94** are individually manipulated to a given anatomical feature, such as e.g., the inferior vena cava **78**, tricuspid valve **76**, or superior vena cava **80**. Once so located, the anchoring devices **90**, **92**, **94** are then attached to these anatomical structures. Each anchoring device **90**, **92**, **94** includes an anchor member **100** that facilitates such attachment. The particular configuration of the anchor member **100** will depend upon the anatomical feature in question. The anchor member **100** could include a deployable helix, passive tines, a deployable wire loop, an actuable clamp, or other structure to temporarily secure the anchoring device in the desired area.

[0051] Sensor **14** is deployed through the lumen **88** via an appropriate device such as lead **10**, a catheter, a stylet or a

similar steerable mechanism. After the anchoring members 90, 92 are secured to their respective anatomical structures, as schematically illustrated in FIG. 10, the sensor 14 is moved in the target area to locate the coronary sinus 72.

[0052] Various techniques may be employed to ultimately deliver a desired device such as a lead to the coronary sinus 72, with the various embodiments of the sensor 14. In one embodiment, the sensor(s) 14 are formed as part of the lead 10 and the lead 10 is simply deployed. Alternatively, the sensor(s) are attached to a catheter or a guidewire, which is deployed within the coronary sinus. The lead or other device is then deployed via the catheter or over the guidewire. A dedicated device having the sensor(s) 14 may be used to "map" the right atrium and identify the location of the coronary sinus. Once done, the sensor(s) 14 are removed and the lead or other device is inserted, using the known or mapped position of the coronary sinus.

[0053] FIG. 11 is a schematic diagram illustrating one embodiment of a device having thermistor for navigating through cardiac anatomy. A lead 100, or other navigable device, includes a thermistor 102 disposed near a distal end of the lead 100. The lead 100 includes sheathing 104 that may encase or, as in the illustrated embodiment, partially expose a portion of the thermistor 102 to allow for rapid response times. The thermistor 102 is electrically connected to a wheatstone bridge arrangement 106 and a lock-in amplifier 108. Such an arrangement increase the signal to noise ratio and permits improved data collection and analysis. The output from the lock-in amplifier 108 is passed to a computer 110 for processing and subsequent display.

[0054] In this embodiment, the lock-in amplifier 108 measures a relatively small signal despite significant noise by taking advantage of an AC character of the signal. The illustrated embodiment measures the resistance changes of the thermistor 102 that forms portion of the wheatstone bridge 106, with the lock-in amplifier 108 providing an AC signal. The lock-in amplifier 102 provides a reference signal at the same frequency of the sensed signal with a constant phase difference via a phase locked loop. Demodulating the signal creates a DC signal that is proportional to the original AC signal. By passing this signal through a low pass filter, only a DC signal remains that is proportional to the sensed signal. The noise is determined by the bandwidth of the low pass filter. Such an arrangement provides fast response times and accurately measures temperature differential in the necessary range.

[0055] While multiple embodiments are disclosed, still other embodiments of the present invention will become apparent to those skilled in the art from the following detailed description, which shows and describes illustrative embodiments of the invention. As will be realized, the invention is capable of modifications in various obvious aspects, all without departing from the spirit and scope of the present invention. Accordingly, the drawings and detailed description are to be regarded as illustrative in nature and not restrictive.

1. A device comprising:

a lead body navigable within portions of a cardiac anatomy;

a sensor disposed on the lead body and sensing a physical parameter;

a navigation processor communicatively coupled with the sensor for receiving the sensed physical parameters and manipulating the sensed physical parameters into navigational data; and

a navigational output device communicatively coupled with the navigational processor, wherein the navigational data is output by the navigational output device.

2. The device of claim 1, wherein the sensor is a temperature sensor.

3. The device of claim 2, wherein the temperature sensor is a thermistor.

4. The device of claim 2, wherein the temperature sensor is a thermocouple.

5. The device of claim 1, wherein the sensor is selected from the group consisting of: an oxygen sensor, a pressure sensor, a chemical sensor, an ultrasound sensor, and an optical sensor.

6. The device of claim 1, wherein a plurality of sensors are disposed on the lead body.

7. The device of claim 1, wherein the navigational output device transmits audible navigational instructions.

8. The device of claim 1, wherein the navigational output device is a visual display.

9. The device of claim 1, further comprising:

a patient imaging device for providing patient image data; and

a supplemental patient parameter monitor for sensing supplemental patient parameter, wherein the patient image data and the supplemental patient parameter are provided to the navigational processor so that the navigational data is based upon the supplemental patient parameter, the image data, and the sensed physical parameter.

10. The device of claim 1, wherein the navigational data provides direction for moving the lead body to a targeted anatomical feature.

11. The device of claim 1, wherein the navigational data provides confirmation if the lead body is at a targeted anatomical feature.

12. A system comprising:

means for manipulating and directing a device within cardiac an anatomy;

means for sensing a physical parameter;

means for processing the physical parameter into navigational information; and

means for presenting the navigational information;

13. The system of claim 12, wherein the means for presenting include an audible command.

14. The system of claim 12, wherein the means for presenting include a visual display.

15. The system of claim 12, further comprising

means for acquiring imaging data; and

means for combining the imaging data and the navigational information for presentation by the means for presenting.

16. A method of navigating a lead within cardiac anatomy, the method comprising:

passing a lead having a temperature sensor into a right atrial chamber;

sensing temperature values within the right atrial chamber to determine an averaged value;

sensing temperature values within the coronary sinus;

comparing the temperature values within the coronary sinus to the averaged temperature value and determining that the lead is within the coronary sinus based upon the comparison.

**17.** A method of navigating a lead within cardiac anatomy, the method comprising:

directing a lead having a temperature sensor into a right atrial chamber;

determining an average temperature value for the right atrial chamber;

moving the lead about the right atrial chamber to obtain temperature values; and

moving the lead towards a targeted area of the right atrial chamber based upon increased temperature values.

**18.** The method of claim 17, further comprising confirming that the lead has reached the targeted area based upon the increased temperature values.

**19.** The method of claim 18, wherein data from the temperature sensor is processed to provide audible navigation information.

**20.** The method of claim 18, wherein data from the temperature sensor is processed to provide graphical navigation information.

**21.** The method of claim 18, further comprising:

identifying one or more known anatomical features having a predetermined spatial relationship to the targeted area; and

defining a search area through which the sensor is moved based upon the identification of the one or more known anatomical features.

\* \* \* \* \*

专利名称(译)	使用传感器识别解剖位置的系统和方法		
公开(公告)号	<a href="#">US20050165324A1</a>	公开(公告)日	2005-07-28
申请号	US10/781111	申请日	2004-02-18
[标]申请(专利权)人(译)	RECEVEUR ROGIER LARIK VINCENT 范德克鲁克RON DUYSENS VICTOR HOUBEN RICHARD P 鲁克霍夫尼古拉斯M FERON约翰·C·		
申请(专利权)人(译)	RECEVEUR ROGIER LARIK VINCENT 范德克鲁克RON DUYSENS VICTOR HOUBEN RICHARD P. LOKHOFF尼古拉斯M. FERON JOHN C.		
当前申请(专利权)人(译)	美敦力公司, INC.		
[标]发明人	RECEVEUR ROGIER LARIK VINCENT VAN DER KRUK RON DUYSENS VICTOR HOUBEN RICHARD P M LOKHOFF NICOLAAS M FERON JOHN C M J		
发明人	RECEVEUR, ROGIER LARIK, VINCENT VAN DER KRUK, RON DUYSENS, VICTOR HOUBEN, RICHARD P.M. LOKHOFF, NICOLAAS M. FERON, JOHN C.M.J.		
IPC分类号	A61B5/00 A61B5/027 A61B5/03 A61B5/107 A61B8/12 A61B17/00 A61B19/00 A61M25/01 A61N1/05 A61B5/02		
CPC分类号	A61B5/027 A61B5/036 A61B5/1459 A61B8/12 A61B19/46 A61B19/52 A61N1/056 A61B2017/00088 A61B2017/00092 A61B2017/00101 A61B2017/00115 A61B2017/00243 A61B2019/464 A61B19/5244 A61B34/20 A61B90/06 A61B90/36 A61B2090/064		
优先权	60/539202 2004-01-26 US		
外部链接	<a href="#">Espacenet</a> <a href="#">USPTO</a>		

#### 摘要(译)

传感器设置在引线上并且感测指示期望的解剖目标的各种物理参数, 例如冠状窦。来自传感器的数据用于导航到解剖目标和/或确认已经到达解剖目标。在一个实施例中, 传感器是温度传感器, 并且冠状窦中和周围的升高的温度值用于导航目的。

