



US008483788B2

(12) **United States Patent**  
**Miller et al.**

(10) **Patent No.:** **US 8,483,788 B2**  
(45) **Date of Patent:** **Jul. 9, 2013**

(54) **MOTION COMPENSATION IN A SENSOR**  
(75) Inventors: **Mark C. Miller**, Longmont, CO (US);  
**Charles Haisley**, Boulder, CO (US); **Jill T. Klomhaus**, Longmont, CO (US);  
**Edward M. McKenna**, Boulder, CO (US); **Braddon M. Van Slyke**, Arvada, CO (US)

5,094,240 A 3/1992 Muz  
5,226,417 A 7/1993 Swedlow et al.  
5,275,159 A 1/1994 Griebel  
5,348,003 A 9/1994 Caro  
5,429,129 A 7/1995 Lovejoy et al.  
5,474,065 A 12/1995 Meathrel et al.  
5,482,036 A 1/1996 Diab et al.  
5,483,646 A 1/1996 Uchikoga  
5,511,546 A 4/1996 Hon  
5,619,992 A 4/1997 Guthrie et al.

(Continued)

(73) Assignee: **Covidien LP**, Mansfield, MA (US)  
(\* ) Notice: Subject to any disclaimer, the term of this patent is extended or adjusted under 35 U.S.C. 154(b) by 650 days.

**FOREIGN PATENT DOCUMENTS**

DE 19632361 2/1997  
EP 0127947 12/1984

(Continued)

(21) Appl. No.: **12/714,531**

**OTHER PUBLICATIONS**

(22) Filed: **Feb. 28, 2010**

Yang et al.; "Development of the ring sensor for healthcare automation." *Robotics and Autonomous Systems*, 2000, vol. 30, pp. 273-281.

(65) **Prior Publication Data**

(Continued)

US 2011/0213226 A1 Sep. 1, 2011

(51) **Int. Cl.**  
**A61B 5/00** (2006.01)

*Primary Examiner* — Clayton E Laballe

*Assistant Examiner* — Linda B Smith

(52) **U.S. Cl.**  
USPC ..... **600/323**

(74) *Attorney, Agent, or Firm* — Fletcher Yoder

(58) **Field of Classification Search**  
USPC ..... 600/323, 310, 104  
See application file for complete search history.

(57) **ABSTRACT**

A system and method for compensating for movement in a sensor. A sensor may include an emitter configured to transmit light, a detector configured to receive the transmitted light via a respective light path, and an accelerometer configured to measure a change in distance between the detector and the emitter. The sensor may transmit the measurements relating to the change in distance between the detector and the emitter to a pulse oximetry monitor. The pulse oximetry monitor may generate an attenuation factor corresponding to the change in the distance between the detector and the emitter that may be used to compensate for movement in a sensor when calculating physiological parameters of a patient.

(56) **References Cited**

**U.S. PATENT DOCUMENTS**

3,721,813 A 3/1973 Condon et al.  
4,971,062 A 11/1990 Hasebe et al.  
4,974,591 A 12/1990 Awazu et al.  
5,025,791 A 6/1991 Niwa  
5,028,787 A 7/1991 Rosenthal et al.  
5,035,243 A 7/1991 Muz  
5,065,749 A 11/1991 Hasebe et al.  
5,084,327 A 1/1992 Stengel

**11 Claims, 4 Drawing Sheets**

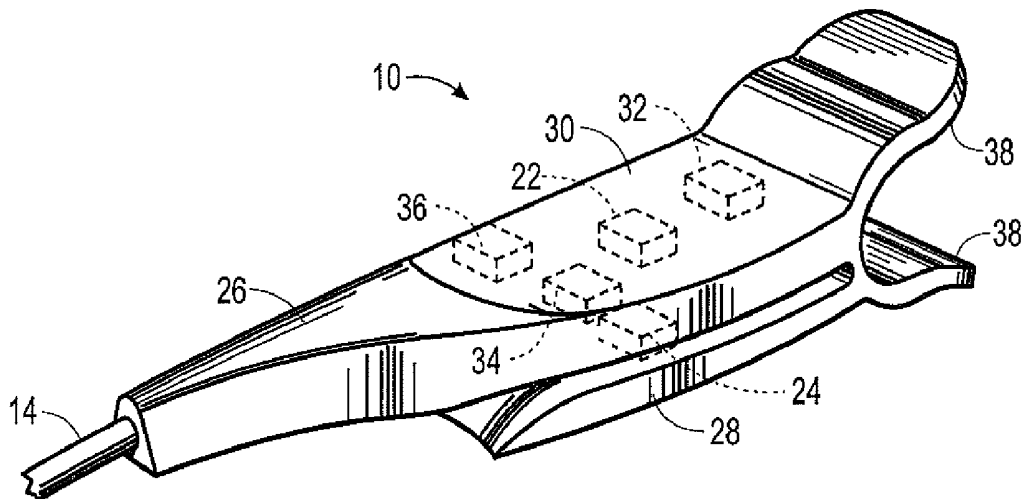

U.S. PATENT DOCUMENTS

5,666,952	A	9/1997	Fuse et al.	
D393,830	S	4/1998	Tobler et al.	
5,769,785	A	6/1998	Diab et al.	
5,779,631	A	7/1998	Chance	
5,871,442	A	2/1999	Madarasz et al.	
5,964,701	A	10/1999	Asada et al.	600/300
6,036,642	A	3/2000	Diab et al.	
6,081,742	A	6/2000	Amano et al.	
6,144,444	A	11/2000	Haworth et al.	
6,261,236	B1	7/2001	Grimblatov	
6,285,895	B1	9/2001	Ristolainen et al.	
6,353,750	B1	3/2002	Kimura et al.	
6,419,671	B1	7/2002	Lemberg	
6,461,305	B1	10/2002	Schnall	
6,501,975	B2	12/2002	Diab et al.	
6,512,937	B2	1/2003	Blank et al.	
6,564,088	B1	5/2003	Soller et al.	
6,589,172	B2	7/2003	Williams et al.	
6,591,122	B2	7/2003	Schmitt	
RE38,492	E	4/2004	Diab et al.	
6,791,689	B1	9/2004	Weckström	
6,793,654	B2	9/2004	Lemberg	
6,826,419	B2	11/2004	Diab et al.	
6,916,289	B2	7/2005	Schnall	
6,963,777	B2	11/2005	Lincoln et al.	
6,971,580	B2	12/2005	Zhu et al.	
6,992,751	B2	1/2006	Okita et al.	
7,198,778	B2	4/2007	Achilefu et al.	
7,236,811	B2	6/2007	Schmitt	
7,238,159	B2	7/2007	Banet et al.	
7,313,427	B2	12/2007	Benni	
7,469,158	B2	12/2008	Cutler et al.	
7,572,229	B2	8/2009	Yeo et al.	
7,574,244	B2	8/2009	Eghbal et al.	
8,073,518	B2	12/2011	Chin	600/344
2004/0098009	A1	5/2004	Boecker et al.	
2004/0204638	A1	10/2004	Diab et al.	
2005/0043616	A1	2/2005	Chinchoy	
2005/0075550	A1	4/2005	Lindekugel	
2005/0113656	A1	5/2005	Chance	
2005/0119708	A1	6/2005	Haefner	
2005/0177034	A1	8/2005	Beaumont	
2005/0197548	A1	9/2005	Dietiker	
2006/0009809	A1	1/2006	Marcovecchio et al.	
2006/0058594	A1	3/2006	Ishizuka et al.	
2006/0122661	A1	6/2006	Mandell	
2006/0247501	A1	11/2006	Ali	
2007/0043282	A1	2/2007	Mannheimer et al.	
2007/0073121	A1	3/2007	Hoarau et al.	
2007/0208233	A1	9/2007	Kovacs	
2007/0208262	A1	9/2007	Kovacs	
2008/0154098	A1	6/2008	Morris et al.	

FOREIGN PATENT DOCUMENTS

FR	2685865	7/1993
JP	4191642	7/1992

JP	6154177	6/1994
JP	7136150	5/1995
JP	7236625	9/1995
JP	10216115	8/1998
JP	2003210438	7/2003
JP	2003275192	9/2003
JP	2004089546	3/2004
JP	2005095606	4/2005
WO	WO9316629	2/1993
WO	WO9502358	1/1995
WO	WO02062213	8/2002
WO	WO03005893	1/2003
WO	WO2005009221	2/2005
WO	WO2005010567	2/2005
WO	WO2006109072	10/2006
WO	WO2007041296	4/2007

OTHER PUBLICATIONS

Rhee et al.; "Artifact-Resistant, Power-Efficient Design of Finger-Ring Plethysmographic Sensor—Part I: Design and Analysis," *Proceedings of the 22nd Annual EMBS International Conference*, Jul. 23-28, 2000; pp. 2792-2795, Chicago, Illinois.

Cysewska-Sobusaik, "Metrological Problems With noninvasive Transillumination of Living Tissues," *Proceedings of SPIE*, 2001, pp. 15-24, vol. 4515.

Rhee et al.; "Artifact-Resistant, Power-Efficient Design of Finger-Ring Plethysmographic Sensor," *IEEE Transactions on Biomedical Engineering*, Jul. 2001, pp. 795-805, vol. 48, No. 7.

Relente et al.; "Characterization and Adaptive Filtering of Motion Artifacts in Pulse Oximetry using Accelerometers," *Proceedings of the Second joint EMBS/BMES Conference*, Oct. 23-26, 2002; pp. 1769-1770, Houston, Texas.

Tobata et al.; "Study of Ambient Light Affecting Pulse Oximeter Probes," *Ikigaku (Medical Technology)*, 2002, pp. 475-476, vol. 71, No. 10, (Article in Japanese—contains English summary of article).

Shaltis et al.; "Implementation and Validation of a Power-Efficient, High-Speed Modulation Design for Wireless Oxygen Saturation Measurement Systems," *IEEE*, 2002, pp. 193-194.

Aoyagi, "Pulse oximetry: its invention, theory, and future," *Journal of Anesthesia*, vol. 17, pp. 259-266 (2003).

Itoh et al.; "Pulse Oximeter," *Toyaku Zasshi (Toyaku Journal)*, 2003, pp. 50-54, vol. 25, No. 8 (Article in Japanese—contains English summary of article).

Matsuzawa et al.; "Pulse Oximeter," *Home Care Medicine*, Jul. 2004, pp. 42-45 (Article in Japanese—contains English summary of article).

Odagiri, "Pulse Wave Measuring Device," *Micromechatronics*, (undated), pp. 6-11, vol. 42, No. 3 (Article in Japanese—contains English summary of article).

\* cited by examiner

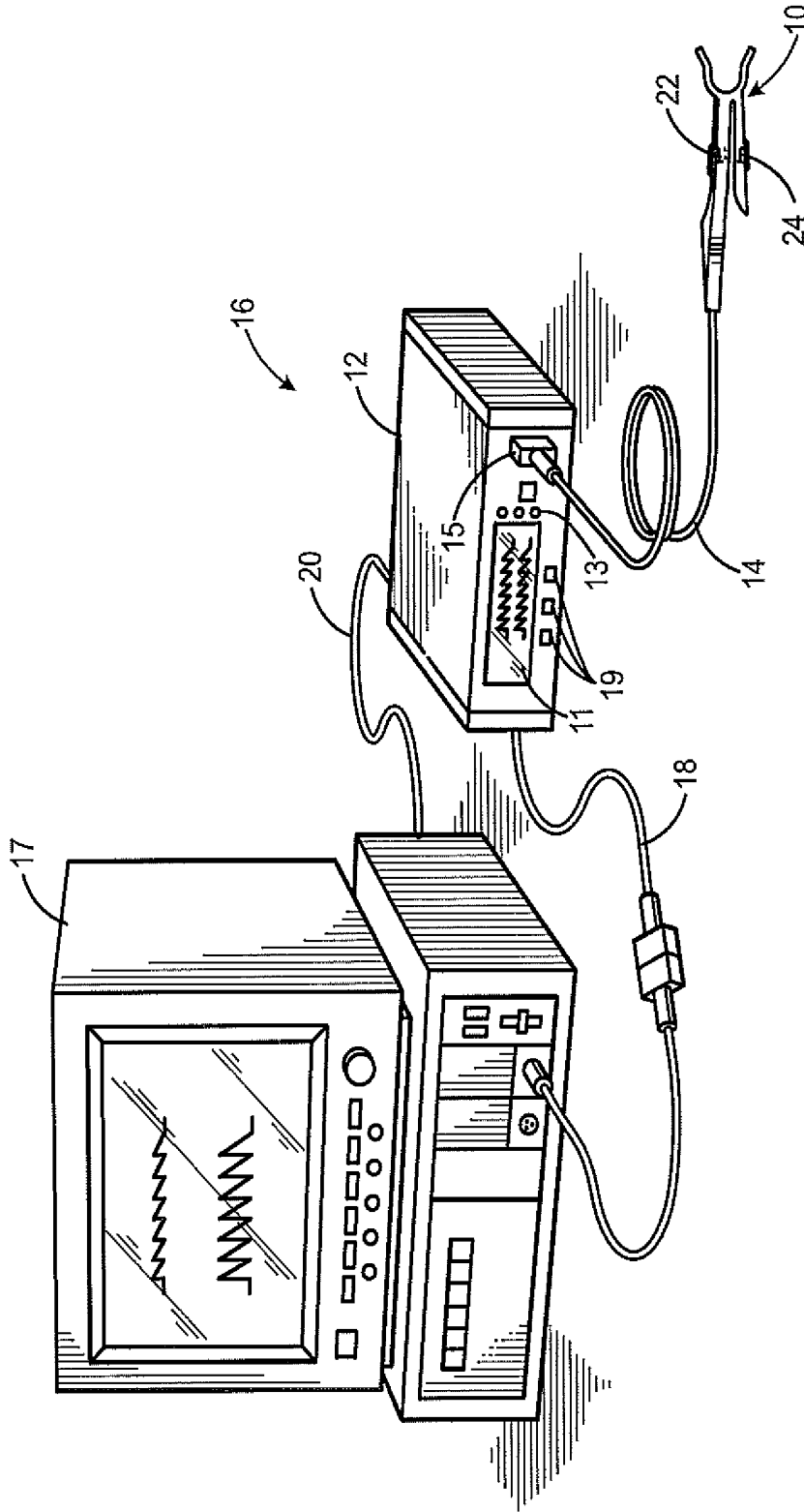

FIG. 1

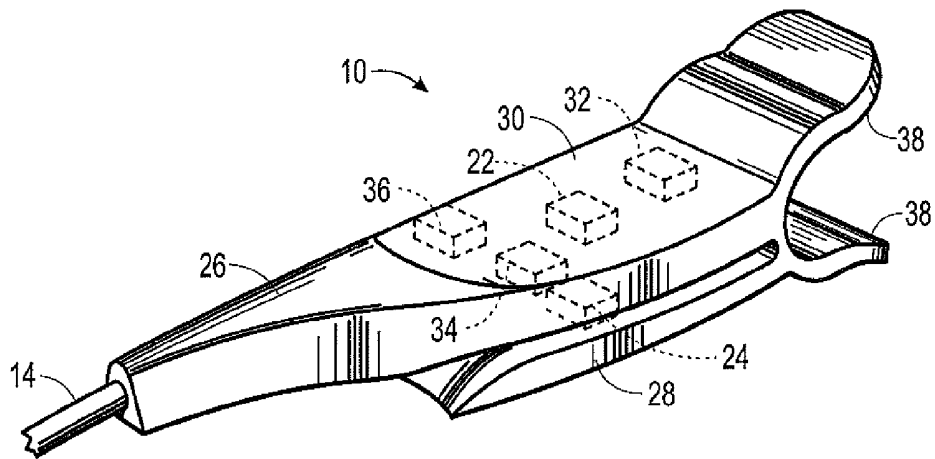

FIG. 2

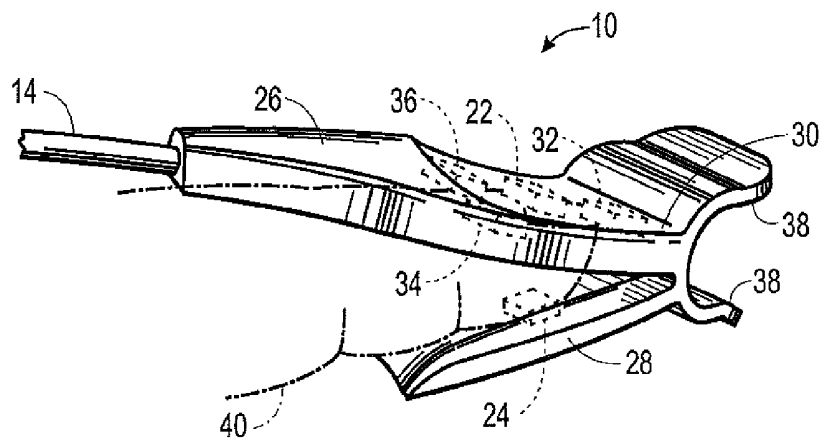

FIG. 3

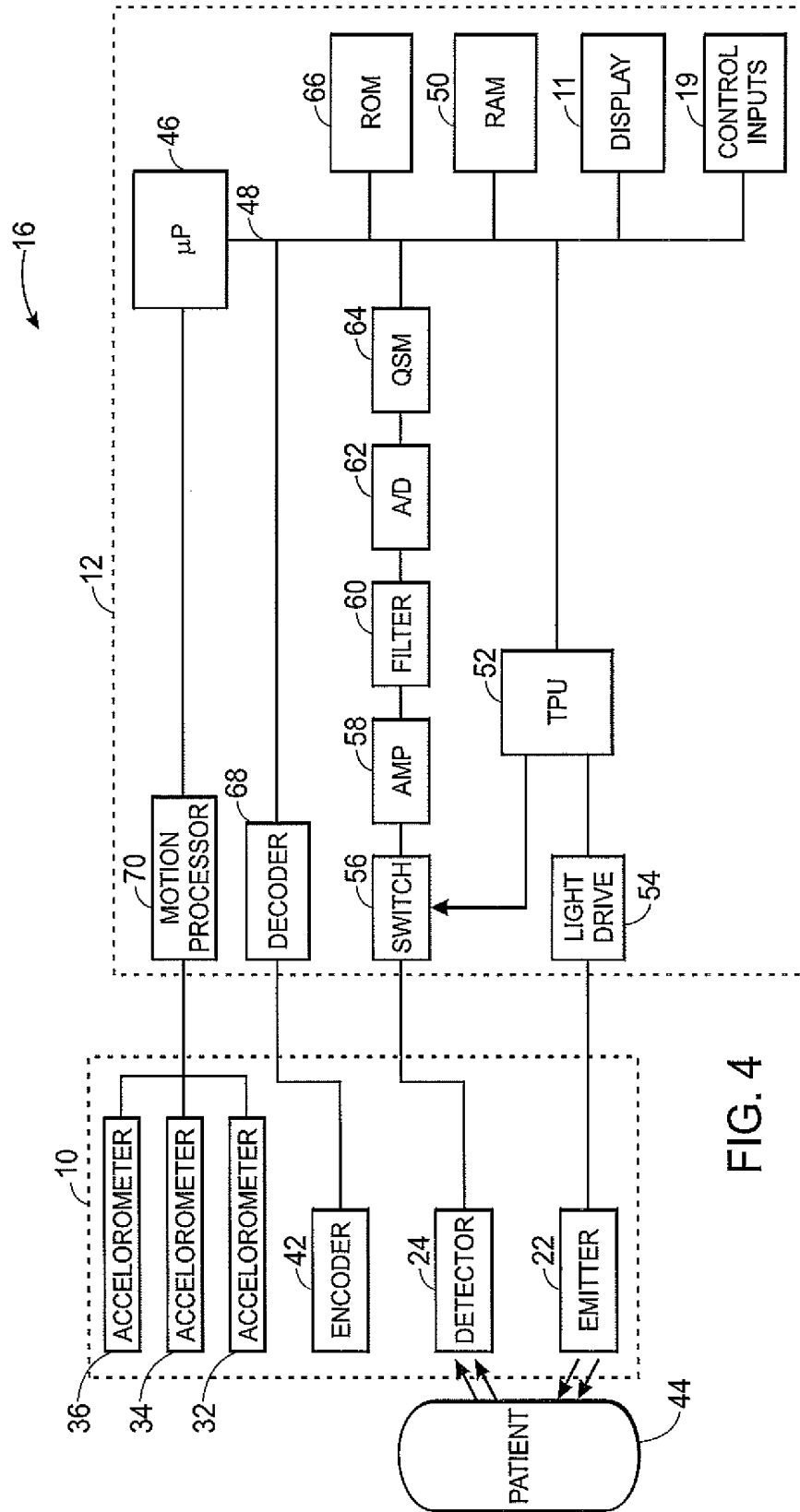

FIG. 4

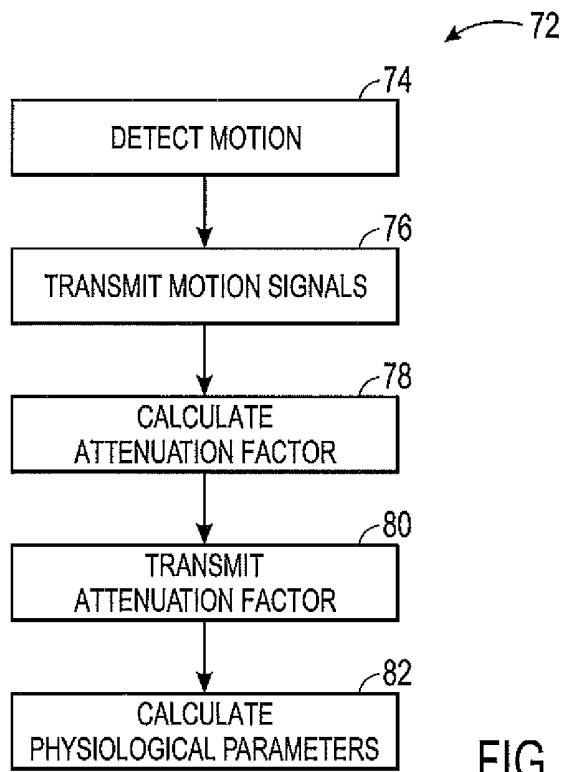

FIG. 5

## MOTION COMPENSATION IN A SENSOR

## BACKGROUND

The present disclosure relates generally to medical devices and, more particularly, to sensors used for sensing physiological parameters of a patient.

This section is intended to introduce the reader to various aspects of art that may be related to various aspects of the present disclosure, which are described and/or claimed below. This discussion is believed to be helpful in providing the reader with background information to facilitate a better understanding of the various aspects of the present disclosure. Accordingly, it should be understood that these statements are to be read in this light, and not as admissions of prior art,

In the field of medicine, doctors often desire to monitor certain physiological characteristics of their patients. Accordingly, a wide variety of devices have been developed for monitoring many such physiological characteristics. Such devices provide doctors and other healthcare personnel with the information they need to provide the best possible healthcare for their patients. As a result, such monitoring devices have become an indispensable part of modern medicine.

One technique for monitoring certain physiological characteristics of a patient is commonly referred to as pulse oximetry, and the devices built based upon pulse oximetry techniques are commonly referred to as pulse oximeters. Pulse oximetry may be used to measure various blood flow characteristics, such as the blood-oxygen saturation of hemoglobin in arterial blood, the volume of individual blood pulsations supplying the tissue, and/or the rate of blood pulsations corresponding to each heartbeat of a patient. In fact, the "pulse" in pulse oximetry refers to the time varying amount of arterial blood in the tissue during each cardiac cycle.

Pulse oximeters typically utilize a non-invasive sensor that transmits light through a patient's tissue and that photoelectrically detects the absorption and/or scattering of the transmitted light in such tissue. One or more of the above physiological characteristics may then be calculated based upon the amount of light absorbed or scattered. More specifically, the light passed through the tissue is typically selected to be of one or more wavelengths that may be absorbed or scattered by the blood in an amount correlative to the amount of the blood constituent present in the blood. The amount of light absorbed and/or scattered may then be used to estimate the amount of blood constituent in the tissue using various algorithms.

The light sources utilized in pulse oximeters typically are placed in a certain position on a patient. For the sensor to operate optimally, this position should be maintained. Accordingly, movement of the sensor due to the movements of a patient may lead to erroneous results.

## BRIEF DESCRIPTION OF THE DRAWINGS

Advantages of the disclosed techniques may become apparent upon reading the following detailed description and upon reference to the drawings in which:

FIG. 1 illustrates a perspective view of a pulse oximeter in accordance with an embodiment;

FIG. 2 is a perspective view of a clip style embodiment of the sensor assembly shown in FIG. 1, in accordance with an embodiment;

FIG. 3 is a perspective view of the sensor assembly shown in FIG. 2 placed on a patient's finger, in accordance with an embodiment;

FIG. 4 illustrates a simplified block diagram of the pulse oximeter in FIG. 1, in accordance with an embodiment; and

FIG. 5 illustrates a flow chart of the operation of a pulse oximeter in FIG. 1, according to an embodiment.

## DETAILED DESCRIPTION OF SPECIFIC EMBODIMENTS

One or more specific embodiments of the present techniques will be described below. In an effort to provide a concise description of these embodiments, not all features of an actual implementation are described in the specification. It should be appreciated that in the development of any such actual implementation, as in any engineering or design project, numerous implementation-specific decisions must be made to achieve the developers' specific goals, such as compliance with system-related and business-related constraints, which may vary from one implementation to another. Moreover, it should be appreciated that such a development effort might be complex and time consuming, but would nevertheless be a routine undertaking of design, fabrication, and manufacture for those of ordinary skill having the benefit of this disclosure.

Present embodiments relate to non-invasively measuring physiologic parameters corresponding to blood flow in a patient by emitting light into a patient's tissue with light emitters (e.g., light emitting diodes) and photoelectrically detecting the light after it has passed through the patient's tissue. More specifically, present embodiments are directed to a pulse oximeter that includes a sensor and a monitor. The sensor may include at least one accelerometer that may operate to measure a change in distance between the emitter and the detector of the sensor. The sensor may transmit the measured change in the distance between the emitter and the detector to a motion processor in a pulse oximetry monitor. The motion processor may calculate a gain factor corresponding to the change in the distance between the detector and the emitter via, for example, an equation related to a model distance between the emitter and the detector, an expectation model of photon behavior between the emitter and the detector, and the measurements from the accelerometer. Alternatively, the motion processor may calculate an attenuation factor corresponding to the change in the distance between the detector and the emitter via, for example, comparing the measurements received from the one or more accelerometers with motion measurements and corresponding attenuation factors stored in a look-up table (e.g., stored in a table memory). The calculated attenuation factor may be used by the monitor to compensate for movement in a sensor when calculating physiological parameters of a patient.

FIG. 1 depicts a sensor 10 that may be used in conjunction with a monitor 12 in accordance with an embodiment of the present disclosure. The sensor 10 may be coupled to the monitor 12 via sensor cable 14 and sensor connector 15, or the sensor 10 may be coupled to a transmission device (not shown) to facilitate wireless transmission between the sensor 10 and the monitor 12. It should be noted that sensor cable 14 may be able to transmit a plurality of signals to the sensor 10 as well as transmit a plurality of signals from the sensor 10 to the monitor 12. The sensor 10 and the monitor 12 may generally be referred to as a pulse oximeter 16. Pulse oximeter 16 may be any suitable pulse oximeter, such as those available from Nellcor Puritan Bennett, LLC.

The monitor 12 of the pulse oximeter 16 may be configured to display calculated parameters on a display 11. As illustrated in FIG. 1, the display 11 may be integrated into the monitor 12 and may be configured to display computed physiological data including, for example, an oxygen saturation percentage, a pulse rate, and/or a plethysmographic

waveform of a patient. As is known in the art, the oxygen saturation percentage may be a functional arterial hemoglobin oxygen saturation measurement in units of percentage SpO<sub>2</sub>, while the pulse rate may indicate a patient's pulse rate in beats per minute. The monitor 12 may also display information related to alarms, monitor settings, and/or signal quality via indicator lights 13.

Furthermore, to upgrade conventional operation provided by the monitor 12 (e.g., to provide additional functions), the monitor 12 may be coupled to a multi-parameter patient monitor 17 via a cable 18 connected to a sensor input port or via a cable 20 connected to a digital communication port, or through wireless transmission components (not shown). To facilitate user input, the monitor 12 may include a plurality of control inputs 19. The control inputs 19 may include fixed function keys, programmable function keys, and soft keys. Specifically, the control inputs 19 may correspond to soft key icons in the display 11. Pressing control inputs 19 associated with, or adjacent to, an icon in the display may select a corresponding option that may change the operation of, for example, the monitor 12 and/or the sensor 10.

The sensor 10 may be a clip style sensor capable of being applied to, for example, a patient's finger. The sensor 10 may include an emitter 22 and a detector 24. As depicted, the emitter 22 and detector 24 may be arranged in a transmittance-type configuration in which the emitter 22 and detector 24 are typically placed on differing sides of the sensor site. In this manner, the detector 24 may detect light that has passed through one side of a tissue site to an opposite side of the tissue site. Alternatively, the sensor 10 may be a flexible bandage style sensor such as those available from Nellcor Puritan Bennett, LLC. This flexible bandage style sensor may be, for example, wrapped around a patient's finger and may be a reflectance style sensor in which the emitter 22 and detector 24 are placed on the same side of the sensor site. Reflectance type sensors may operate by emitting light into the tissue and detecting the reflected light that is transmitted and scattered by the tissue. That is, reflectance type sensors detect light photons that are scattered back to the detector 24.

Turning now to FIG. 2, a perspective view of a clip-style embodiment of sensor 10 is shown. The sensor 10 includes an upper clip portion 26 and a lower clip portion 28. As depicted, upper clip portion 26 includes a housing 30, which houses the emitter 22, while the lower clip portion 28 may house the detector 24. In other embodiments the emitter 22 and detector 24 may be reversed. Additionally, the housing 30 may include one or more accelerometers 32, 34, and 36. In one embodiment, three accelerometers 32, 34, and 36 are utilized whereby each accelerometer 32, 34, and 36 measures acceleration in a particular direction in three dimensional space. In this manner, each accelerometer 32, 34, and 36 may measure specific directional acceleration of the sensor 10 so that the acceleration, and thus movement, of the sensor 10 may be measured so that the motion may be compensated for with respect to calculating the optical path between the emitter 22 and the detector 24. In this manner, signal attenuation between the emitter 22 and the detector 24 may be accounted for. Alternatively, a single tri-axis accelerometer may be utilized to measure all movements in three dimensional space for determination of motion for calculation of any changes in the optical path between the emitter 22 and the detector 24.

When three accelerometers 32, 34, and 36 are utilized, the accelerometers 32, 34, and 36 may be placed in the sensor 10, for example, orthogonally (i.e., at right angles to one another) in housing 30 or in the clip 38 of the sensor. For example, accelerometers 32, 34, and 36 may be placed in the upper clip portion 26, the lower clip portion 28, in the clip 38, or in some

combination thereof (e.g., accelerometer 32 in the upper clip portion 26 and accelerometers 34 and 36 in the lower clip portion 28). Furthermore, each of the accelerometers 32, 34, and 36 may be a micro-electromechanical device capable of measuring movement in the sensor 10, i.e. acceleration relative to freefall. By measuring the movement of the sensor 10, potential effects from the motion of the sensor 10 may be adjusted when physiological parameters of a patient are calculated.

FIG. 3 shows the clip-style embodiment of sensor 10 in operation. As depicted, upper clip portion 26 and lower clip portion 28 have been separated, allowing a patient's digit 40 to be inserted in the sensor 10. In one embodiment, light waves may be emitted by emitter 22 into the top of patient digit 40. The light waves may then be transmitted through the patient's digit 40 and received by detector 24. A signal corresponding to the detected light waves may be sent to the monitor 12 via cable 14. Additionally, any movements caused, for example, by tapping of the digit 40 or general movement of the digit 40 may be transmitted as movement signals from the accelerometers 32, 34, and 36 to the monitor 12 via the cable 14. As described below, these movement signals may be used to increase the reliability of calculated physiological characteristics of the patient.

Turning to FIG. 4, a simplified block diagram of a pulse oximeter 16 is illustrated in accordance with an embodiment. Specifically, certain components of the sensor 10 and the monitor 12 are illustrated. As previously noted, the sensor 10 may include an emitter 22, a detector 24, and accelerometers 32, 34, and 36. The sensor 10 may also include an encoder 42. It should be noted that the emitter 22 may be capable of emitting at least two wavelengths of light, e.g., RED and infrared (IR) light, into the tissue of a patient 44 to calculate the patient's 44 physiological characteristics, where the RED wavelength may be between about 600 nanometers (nm) and about 700 nm, and the IR wavelength may be between about 800 nm and about 1000 nm. Alternative light sources may be used in other embodiments. For example, a single wide-spectrum light source may be used, and the detector 24 may be capable of detecting certain wavelengths of light. In another example, the detector 24 may detect a wide spectrum of wavelengths of light, and the monitor 12 may process only those wavelengths which are of interest for use in measuring, for example, water fractions, hematocrit, or other physiologic parameters of the patient 44. It should be understood that, as used herein, the term "light" may refer to one or more of ultrasound, radio, microwave, millimeter wave, infrared, visible, ultraviolet, gamma ray or X-ray electromagnetic radiation, and may also include any wavelength within the radio, microwave, infrared, visible, ultraviolet, or X-ray spectra, and that any suitable wavelength of light may be appropriate for use with the present disclosure.

Additionally the sensor 10 may include an encoder 42, which may contain information about the sensor 10, such as what type of sensor 10 it is (e.g., whether the sensor 10 is intended for placement on a forehead or digit 40) and the wavelengths of light emitted by the emitter 22. Additionally and/or alternatively, the encoder may contain information about the accelerometers 32, 34, and 36. The information in the encoder 42 may allow the monitor 12 to select appropriate algorithms and/or calibration coefficients for calculating the patient's 44 physiological characteristics. Additionally, the encoder 42 may include information relating to the proper charging of the sensor 10. The encoder 42 may, for instance, be a memory on which one or more of the following information may be stored for communication to the monitor 12; the type of the sensor 10; the wavelengths of light emitted by

the emitter 22; and the proper calibration coefficients and/or algorithms to be used for calculating the patient's 44 physiological characteristics. The sensor 10 may be any suitable physiological sensor, such as those available from Nellcor Puritan Bennett LLC.

As previously described, the signals used in conjunction with the emitter 22 and the detector 24 may be utilized for the monitoring of physiologic parameters of the patient 44 while the signals from the encoder 42 may contain information about the sensor 10 to allow the monitor 12 to select appropriate algorithms and/or calibration coefficients for calculating the patient's 44 physiological characteristics. To aid in this calculation, the monitor 12 may further include one or more processors 46 coupled to an internal bus 48. Also connected to the bus 48 may be a RAM memory 50 and the display 11. A time processing unit (TPU) 52 may provide timing control signals to light drive circuitry 54, which controls when the emitter 22 is activated, and if multiple light sources are used, the multiplexed timing for the different light sources. TPU 52 may also control the gating-in of signals from detector 24 through a switching circuit 56. The TPU 52 may control the gating-in of signals from detector 24 to insure that the signals are sampled at the proper time, which may depend at least in part upon which of multiple light sources is activated, if multiple light sources are used. The received signal from the detector 24 may be passed through an (optional) amplifier 58, a low pass filter 60, and an analog-to-digital converter 62 for amplifying, filtering, and digitizing the electrical signals the from the sensor 10. The digital data may then be stored in a queued serial module (QSM) 64, for later downloading to RAM 50 as QSM 64 fills up. In an embodiment, there may be multiple parallel paths of separate amplifier, filter, and A/D converters for multiple light wavelengths or spectra received.

In an embodiment, based at least in part upon the received signals corresponding to the light received by detector 24, processor 46 may calculate the oxygen saturation using various algorithms. These algorithms may use coefficients, which may be empirically determined, and may correspond to the wavelengths of light used. The algorithms may be stored in a ROM 66 and accessed and operated according to processor 46 instructions. The monitor 12 may also include a decoder 68 that may receive signals from the encoder 42. The decoder 68 may, for instance, decode the signals from the encoder 42 and may provide the decoded information to the processor 46. The decoded signals may provide information to the processor 46 such as the type of the sensor 10 and the wavelengths of light emitted by the emitter 22 so that proper calibration coefficients and/or algorithms to be used for calculating the patient's 44 physiological characteristics may be selected and utilized by the processor 46.

As may be seen in FIG. 4, the monitor 12 may also include a motion processor 70. The motion processor 70 may include one or more microprocessors, such as one or more "general-purpose" microprocessors, one or more special-purpose microprocessors and/or application specific integrated circuits (ASICs), or some combination of such processing components. The motion processor 70 may be a part of the processor 46, or the motion processor 70 may be distinct from processor 46. Motion processor 70 may be coupled to accelerometers 32, 34, and 36 and may receive signals from the accelerometers 32, 34, and 36. These signals may correspond to motion in three dimensional space of the sensor 10. For example, the three dimensional space may be represented by a Cartesian coordinate system that may be represented as points relative to three axes (e.g., x, y, and z), where each of the axes may be perpendicular to the other two at the point at

which they cross (e.g., at their origin). Accordingly, the accelerometer 32 may transmit a signal corresponding to motion in an x direction; accelerometer 34 may transmit a signal corresponding to motion in a y direction; and accelerometer 36 may transmit a signal corresponding to motion in a z direction, where the x, y, and z directions are orthogonal to one another and represent three dimensional Cartesian space as described above. Alternatively, a single tri-axis accelerometer, for example, placed along the axis of the emitter 22 and the detector 24, may be utilized to measure all movements in three dimensional space for determination of motion for calculation of any changes in the optical path between the emitter 22 and the detector 24. The motion processor 70 may receive signals from each of the accelerometers 32, 34, and 36 or the single tri-axis accelerometer and may calculate an attenuation factor that accounts for the effect of the detected motion (e.g., acceleration), for example, on the optical signal path between the emitter 22 and the detector 24, as described below with respect to FIG. 5.

FIG. 5 illustrates a flowchart 72 that details an example of a procedure for detecting motion in the sensor 10 as well as accounting for the effects of the detected motion. In step 74, the accelerometers 32, 34, and 36 may detect motion in the sensor 10. This motion may be generated through physical movement of the sensor 10, such as moving a digit 40 surrounded by the sensor 10, or through a combination of compression and/or movement of the sensor 10, such as generated by a patient 44 tapping a digit 40 covered with the sensor 10 on a surface. Movement and/or compression of the sensor 10 may cause signal interference, such that signal artifacts are generated during movement, which may dwarf or mask the pulsatile waveform. Because the monitor 12 is typically calibrated to determine physiological parameters of the patient 44 based on a fixed distance between the emitter 22 and the detector 24, change in the distance therebetween may adversely affect the calculated results. Furthermore, any change in the relative positions of the emitter 22 and detector 24 on the tissue bed of the patient 44 may generate signal interference that can easily mask the underlying pulsatile waveform. For example, the monitor 12 may be calibrated to calculate physiological parameters of the patient 44 based on light traveling a distance d from the emitter 22 to the detector 24. Compression of the tissue may cause the distance d to be lessened, thus potentially causing changes in the amount and strength of the light detected at the detector 24. Additionally, compression of the tissue may cause the photons passing from the emitter 22 to the detector 24 to behave in a different manner, i.e., the tissue compression may cause the tissue to be more dense than decompressed tissue, causing a higher rate of absorption of the photons transmitted between the emitter 22 and the detector 24. Accordingly, absent any indicia that the tissue or the distance between the emitter 22 and the detector 24 has been modified, the monitor 12 will calculate physiological parameters based on the received light at a distance d instead of at the actual distance (e.g., less than or greater than d).

In another example, movement of a patient may generate an air gap between the site of a patient 44 being monitored (e.g., a digit 40) and either the emitter 22 or the detector 24. This air gap can transmit the light substantially differently than light transmitted through tissue of the digit 40. Accordingly, absent any indicia that the movement of the sensor 12 is of the type to induce an air gap, the monitor 12 will calculate physiological parameters based on the received light as if the light has not passed through an air gap.

To overcome these potential calculation errors, the accelerometers 32, 34, and 36 may measure movement of the

sensor 10, the emitter 22, and/or the detector 24. This measurement may be transmitted from the accelerometers 32, 34, and 36 in step 76. As such, any of the accelerometers 32, 34, and 36 registering movement may transmit the measurements to the monitor 12 (specifically to the motion processor 70) via, for example, cable 14. The motion processor 70 may receive these measurements and may calculate an attenuation factor based on the received measurements in step 78.

The calculation of an attenuation factor in step 78 may be based on the received measurements transmitted in step 76. As described above, the measurements may be based on movement (e.g., acceleration) of the sensor 10 that may cause the optical signal path between the emitter 22 and the detector 24 to change. The measurements motion processor may calculate an attenuation factor that will compensate for the motion of the sensor 10. This calculation may be made utilizing, for example, an equation that takes into account the model optical distance between the emitter 22 and the detector 24, an expectation model of photon behavior in the patient's 44 tissue, and the received measurements. The equation for the reflectance of a turbid media such as tissue may be given by the following relation:

$$R(\rho, \mu_a, \mu_s) = C_1 \Phi(\rho) + C_2 J_z(\rho)$$

where C1 and C2 are constants relating to the coupling parameters of fiber to tissue, and  $\Phi(\rho)$  and  $J_z(\rho)$  are given by:

$$\Phi(\rho) = \frac{1}{4\pi D} \left( \frac{\exp(-\mu_{eff} r_1(\rho))}{r_1(\rho)} - \frac{\exp(-\mu_{eff} r_2(\rho))}{r_2(\rho)} \right)$$

and

$$J_z(\rho) = \frac{1}{4\pi \mu_t} \left( \left( \mu_{eff} + \frac{1}{r_1(\rho)} \right) \frac{\exp(-\mu_{eff} r_1(\rho))}{r_1^2(\rho)} + \left( 2z_h + \frac{1}{\mu_t} \right) \left( \mu_{eff} + \frac{1}{r_2(\rho)} \right) \frac{\exp(-\mu_{eff} r_2(\rho))}{r_2^2(\rho)} \right)$$

Where

$$D = \frac{c}{3(\mu'_s + \mu_a)}$$

$$\mu_t = \mu_a + \mu'_s$$

$$\mu_{eff} = \sqrt{3\mu_a \mu_t}$$

Accordingly, the reduced scattering and absorption coefficients become functions of the acceleration vector defined by the spectrometer since various accelerations may produce changes related to physiologic parameters such as "venous sloshing", tissue compression, arterial pressure changes, etc. The change in position of the emitter 22 and detector (ρ) 24 will be adjusted directly from the position changes from one or more of the accelerometers 32, 34, and 36.

These elements may be combined to calculate and generate the attenuation factor, which may relate to the amount that signals from the emitter 22 to the detector 24 are attenuated (i.e., the attenuation factor may relate to photon behavior in the tissue of the patient 44, tissue compression/decompression, and/or any air gaps between the tissue and the emitter 22 and/or the detector 24).

In another embodiment, the calculation of the attenuation factor (step 78) may be made utilizing look-up tables or other stored data results. For example, the received measurements (e.g., motion signals) may be compared to a set of programmed measurements values (e.g., attenuation factors) and the most similar programmed measurement value to the received measurement may be selected. Based on this selection, the motion processor 70 may read out an attenuation

factor corresponding to the selected programmed measurement. These attenuation factors may be determined based on an equation that takes into account the model optical distance between the emitter 22 and the detector 24, an expectation model of photon behavior in the patient's 44 tissue, and the received measurements. These elements may be combined to calculate and generate the attenuation factor, which may relate to the amount that signals from the emitter 22 to the detector 24 are attenuated (i.e., the attenuation factor may relate to photon behavior in the tissue of the patient 44, tissue compression/decompression, and/or any air gaps between the tissue and the emitter 22 and/or the detector 24). The process of reading out attenuation factors corresponding to the selected programmed measurements may be repeated for any measurements received from accelerometers 32, 34, and 36. That is, if more than one measurement is received (i.e., if more than one of the accelerometers 32, 34, and 36 measures movement) the motion processor 70 may combine (or keep separate) the attenuation factors corresponding to the received measurements. The determined attenuation factors may be transmitted to the processor 46 in step 80.

The processor 46 may receive the attenuation factor from the motion processor 70 in step 82. Based on the received attenuation factor, the processor 46 may make adjustments to the calculation of the physiological parameters of the patient 44. For example, the attenuation factor may be used to change the value of a pulse that corresponds to a physiological parameter of a patient 44 at a given time. The attenuation factor may be applied in a calculation by the processor 46 to remove any effects of motion on the calculated physiological parameter. For example, the attenuation factor may alter the algorithms selected by the processor 46 for use in calculating various physiological parameters of the patient 44. As previously noted, based at least in part upon the received signals corresponding to the light received by detector 24, processor 46 may calculate the oxygen saturation using various algorithms. These algorithms may use coefficients, which may be empirically determined, and may correspond to the wavelengths of light used. The algorithms may be stored in a ROM 66 and accessed and operated according to processor 46 instructions. The attenuation factors may provide the processor 46 with information related to the actual distance between the emitter 22 and the detector 24, the photon behavior in either compressed or decompressed tissue, and/or any air gaps so that the processor 46 may select proper calibration coefficients and/or algorithms to be used for calculating the patient's 44 physiological characteristics by the processor 46.

Furthermore, pulse identification and qualification may be boosted through selection of the proper coefficients via incorporating the attenuation factors in the selection process. As described above, digitized optical signals may be provided to the processor 46 and proper coefficients for calculating the patient's 44 physiological characteristics may be selected based on these digitized optical signals. However, before the physiological characteristics are calculated, pulses in the digitized optical signals may first be identified and qualified as likely arterial pulses. This may be performed by the processor 46 utilizing a pre-trained neural network. Furthermore, the attenuation factors may be utilized by the processor 46 as, for example, an input to the neural network or a selection criterion for results of the neural network. In this manner, the processor 46 may identify the pulses by examining their amplitude, shape, and frequency, specifically pre-processed red and infra-red signals, average pulse period, lowpass waveforms from the low pass filter 60 and the results may include indications of the degree of arrhythmia, pulse amplitude variations, individual pulse quality, pulse beep notifica-

tion, and qualified pulse periods and age, (i.e. the outputs may indicate the degree of arrhythmia and individual pulse quality). Through the use of the attenuation factors, a greater number of qualified pulses may be generated. Further, based on the greater number of qualified (i.e. reliable) pulses, the veracity of the measurements displayed on the display 11, and, thus, the overall reliability of the pulse oximeter 16 may be increased.

While the disclosure may be susceptible to various modifications and alternative forms, specific embodiments have been shown by way of example in the drawings and have been described in detail herein. However, it should be understood that the embodiments provided herein are not intended to be limited to the particular forms disclosed. Indeed, the disclosed embodiments may not only be applied to measurements of blood oxygen saturation, but these techniques may also be utilized for the measurement and/or analysis of other blood constituents. For example, using the same, different, or additional wavelengths, the present techniques may be utilized for the measurement and/or analysis of carboxyhemoglobin, met-hemoglobin, total hemoglobin, fractional hemoglobin, intravascular dyes, and/or water content. Rather, the various embodiments may cover all modifications, equivalents, and alternatives falling within the spirit and scope of the disclosure as defined by the following appended claims.

What is claimed is:

1. A pulse oximetry system comprising:  
a sensor assembly comprising:  
an emitter configured to transmit light;  
a detector configured to receive the transmitted light via a light path; and  
an accelerometer configured to measure a change in motion that corresponds to a change in distance between the detector and the emitter along the light path; and  
a pulse oximetry monitor configured to be coupled to the sensor, wherein the pulse oximetry monitor comprises a motion processor configured to receive measurements relating to the change in distance between the detector and the emitter from the accelerometer and to calculate an attenuation factor related to the measurements from the accelerometer.
2. The pulse oximetry system, as set forth in claim 1, wherein the attenuation factor is calculated based on an equation related to a model distance between the emitter and the detector, an expectation model of photon behavior between

the emitter and the detector, and the measurements from the accelerometer to quantify attenuation of the transmitted light due to motion in the sensor assembly.

3. The pulse oximetry system, as set forth in claim 1, comprising a look-up table configured to store a motion measurement corresponding to the attenuation factor, wherein the attenuation factor is calculated based on a comparison between the measurements from the accelerometer and the motion measurement to quantify attenuation of the transmitted light due to motion in the sensor assembly.

4. The pulse oximetry system, as set forth in claim 1, comprising a processor configured to utilize the attenuation factor to calculate a physiological parameter.

5. The pulse oximetry system, as set forth in claim 4, comprising a display configured to display a representation of the physiological parameter.

6. A method comprising:

detecting motion of a physiological sensor via an accelerometer;

transmitting signals indicative of the motion of the physiological sensor to a monitor; and

calculating an attenuation factor in the monitor based on the transmitted signals.

7. The method, as set forth in claim 6, wherein calculating the attenuation factor comprises utilizing an equation related to a model distance between an emitter and a detector in the physiological sensor, an expectation model of photon behavior in the physiological sensor, and the transmitted signals to calculate the attenuation factor.

8. The method, as set forth in claim 6, wherein calculating the attenuation factor comprises utilizing a look-up table configured to store a motion measurement corresponding to the attenuation factor, wherein the attenuation factor is calculated based on a comparison between the transmitted signals and the motion measurement.

9. The method, as set forth in claim 6, comprising calculating a physiological parameter based on the attenuation factor.

10. The method, as set forth in claim 6, wherein detecting motion of a physiological sensor comprises measuring movement of the physiological sensor via an accelerometer.

11. The method, as set forth in claim 9, comprising displaying the calculating a physiological parameter on a display.

\* \* \* \* \*

专利名称(译)	传感器中的运动补偿		
公开(公告)号	<a href="#">US8483788</a>	公开(公告)日	2013-07-09
申请号	US12/714531	申请日	2010-02-28
[标]申请(专利权)人(译)	内尔科尔普里坦贝内特公司		
申请(专利权)人(译)	NELLCOR PURITAN BENNETT LLC		
当前申请(专利权)人(译)	COVIDIEN LP		
[标]发明人	MILLER MARK C HAISLEY CHARLES KLOMHAUS JILL T MCKENNA EDWARD M VAN SLYKE BRADDON M		
发明人	MILLER, MARK C. HAISLEY, CHARLES KLOMHAUS, JILL T. MCKENNA, EDWARD M. VAN SLYKE, BRADDON M.		
IPC分类号	A61B5/00		
CPC分类号	A61B5/061 A61B5/14551 A61B5/14552 A61B5/6826 A61B5/6838 A61B5/721 A61B5/02438 A61B2562/0219		
其他公开文献	US20110213226A1		
外部链接	<a href="#">Espacenet</a> <a href="#">USPTO</a>		

摘要(译)

一种用于补偿传感器中的运动的系统和方法。传感器可以包括：发射器，被配置为透射光；检测器，被配置为经由相应的光路接收透射的光；以及加速度计，被配置为测量探测器和发射器之间的距离的变化。传感器可以将与检测器和发射器之间的距离变化有关的测量值发送到脉搏血氧饱和度监测器。脉搏血氧饱和度监测器可以产生对应于检测器和发射器之间的距离的变化的衰减因子，其可以用于在计算患者的生理参数时补偿传感器中的运动。

