



US007306565B2

(12) **United States Patent**
Fraden et al.

(10) **Patent No.:** **US 7,306,565 B2**
(45) **Date of Patent:** **Dec. 11, 2007**

(54) **EAR TEMPERATURE MONITOR AND METHOD OF TEMPERATURE MEASUREMENT**

(75) Inventors: **Jacob Fraden**, La Jolla, CA (US);
Richard K. Ferlito, San Diego, CA (US)

(73) Assignee: **Advanced Monitors Corporation**, San Diego, CA (US)

(*) Notice: Subject to any disclaimer, the term of this patent is extended or adjusted under 35 U.S.C. 154(b) by 128 days.

(21) Appl. No.: **10/887,027**

(22) Filed: **Jul. 8, 2004**

(65) **Prior Publication Data**

US 2004/0254497 A1 Dec. 16, 2004

Related U.S. Application Data

(63) Continuation of application No. 09/927,179, filed on Aug. 8, 2001, now Pat. No. 6,773,405.

(60) Provisional application No. 60/233,104, filed on Sep. 15, 2000.

(51) **Int. Cl.**
A61B 5/00 (2006.01)

(52) **U.S. Cl.** **600/549**

(58) **Field of Classification Search** 600/474, 600/549, 379; 374/100; 702/130, 131
See application file for complete search history.

(56) **References Cited**

U.S. PATENT DOCUMENTS

3,156,117 A 11/1964 Benzinger 600/549

3,531,992 A	10/1970	Moore	600/549
3,681,991 A	8/1972	Eberly, Jr.	
3,872,726 A	3/1975	Kauffeld et al.	
3,893,058 A	7/1975	Keith	
3,903,744 A	9/1975	Cone	
3,933,045 A	1/1976	Fox et al.	
3,935,744 A	2/1976	Beckman	
3,942,123 A	3/1976	Georgi	
3,946,613 A	3/1976	Silver	
3,949,609 A	4/1976	Hammerslag	
3,978,325 A	8/1976	Goldstein et al.	

(Continued)

FOREIGN PATENT DOCUMENTS

CH 514834 C2 4/2001

(Continued)

OTHER PUBLICATIONS

U.S. Patent and Trademark Office, International Search Report and Written Opinion PCT/US2005/004884, Oct. 14, 2005.

(Continued)

Primary Examiner—Max F. Hindenburg

Assistant Examiner—Jonathan M Foreman

(74) *Attorney, Agent, or Firm*—Wood, Herron & Evans, LLP; Kevin G. Rooney

(57) **ABSTRACT**

A continuous body core temperature monitor comprises a pliable ear plug that conforms to the shape of an ear canal and incorporates a temperature sensor that is clamped between the plug and the ear canal wall. The external surface of the plug is connected to an external temperature sensor and a heating element that compensate for a heat lost from the ear canal to the environment by maintaining the temperature gradient between the temperature sensor and the heating element close to zero.

8 Claims, 6 Drawing Sheets

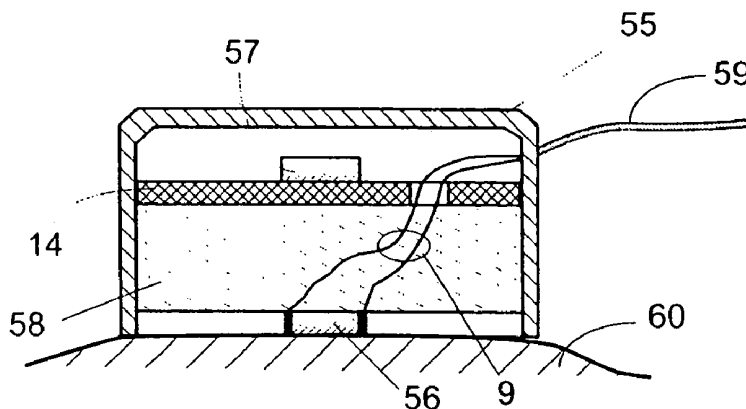

U.S. PATENT DOCUMENTS

4,009,615	A	3/1977	Ruhl	
4,022,063	A	5/1977	West et al.	
4,068,526	A	1/1978	Goldstein	
4,158,965	A	6/1979	Prosky	
4,161,880	A	7/1979	Prosky	
4,166,389	A	9/1979	Montren	
4,183,248	A	1/1980	West	374/164
4,204,429	A	5/1980	Shimazaki et al.	
4,411,535	A	10/1983	Schwarzschild	
4,439,290	A	3/1984	Marfurt et al.	
4,444,517	A	4/1984	Murase	
4,454,370	A	6/1984	Voznick	
4,457,633	A	7/1984	Andrews	
4,461,584	A	7/1984	Murase	
4,464,067	A	8/1984	Hanaoka	
4,487,208	A	12/1984	Kamens	
4,503,862	A	3/1985	Baessler	
4,536,851	A	8/1985	Germanton et al.	
4,537,518	A	8/1985	Murase	
4,539,994	A	9/1985	Baumbach et al.	
4,541,734	A	9/1985	Ishizaka	
4,549,819	A	10/1985	Muramoto et al.	
4,572,365	A	2/1986	Bruno et al.	
4,588,306	A	5/1986	Burger et al.	
4,602,871	A	7/1986	Hanaoka	
4,619,271	A	10/1986	Burger et al.	
4,629,336	A	12/1986	Ishizaka	
4,636,091	A	1/1987	Pompei et al.	
4,648,055	A	3/1987	Ishizaka et al.	
4,651,750	A	3/1987	Northeved	600/549
4,691,713	A	9/1987	Suzuki	
4,729,672	A	3/1988	Takagi	
4,763,522	A	8/1988	Pompei	
4,843,577	A	6/1989	Muramoto	
4,846,583	A	7/1989	Yamamoto	
4,863,279	A	9/1989	Markel et al.	
4,866,621	A	9/1989	Ono	
4,874,253	A	10/1989	Pompei et al.	
4,877,333	A	10/1989	Ota et al.	
4,880,076	A	11/1989	Ahlberg et al.	181/130
4,930,222	A	6/1990	Nakanishi et al.	
4,987,579	A	1/1991	Yoshinaka et al.	
4,993,419	A	2/1991	Pompei et al.	
5,011,294	A	4/1991	Yamaguchi	
5,012,813	A	5/1991	Pompei et al.	
5,017,019	A	5/1991	Pompei	
5,050,612	A	9/1991	Matsumura	
5,056,048	A	10/1991	Seperant	
5,062,432	A	11/1991	James et al.	600/549
5,088,836	A	2/1992	Yamada et al.	
5,088,837	A	2/1992	Shiokawa et al.	
5,116,136	A	5/1992	Newman et al.	
5,126,937	A	6/1992	Yamaguchi et al.	
5,149,200	A	9/1992	Shiokawa et al.	
5,150,969	A	9/1992	Goldberg et al.	
5,178,468	A	1/1993	Shiokawa et al.	
5,183,337	A	2/1993	Pompei	
5,199,436	A	4/1993	Pompei et al.	
5,259,389	A	11/1993	Muramoto et al.	
5,271,407	A	12/1993	Pompei et al.	
5,295,746	A	3/1994	Friauf et al.	
5,325,863	A	7/1994	Pompei	
5,333,622	A	8/1994	Casali et al.	128/864
5,333,784	A	8/1994	Pompei	
5,381,796	A	1/1995	Pompei	
5,445,158	A	8/1995	Pompei	
5,469,855	A	11/1995	Pompei et al.	
D370,860	S	6/1996	Pompei et al.	
5,628,323	A	5/1997	Pompei	
5,632,555	A	5/1997	Gregory et al.	

RE35,554	E	7/1997	Pompei et al.	
5,642,735	A	7/1997	Kolbly	
5,653,238	A	8/1997	Pompei	
5,653,239	A	8/1997	Pompei et al.	
5,655,305	A	8/1997	Fletcher	
5,673,692	A	10/1997	Schulze et al.	600/301
5,688,266	A	11/1997	Edwards et al.	
5,725,308	A	3/1998	Smith et al.	
5,732,711	A	3/1998	Fitzpatrick et al.	
5,743,648	A	4/1998	Zeindler	
5,836,692	A	11/1998	Pompei	
5,873,833	A	2/1999	Pompei	
5,874,736	A	2/1999	Pompei	
5,893,833	A	4/1999	Pompei et al.	
5,894,126	A	4/1999	Pompei et al.	
5,897,552	A	4/1999	Edwards et al.	
6,000,846	A	12/1999	Gregory et al.	
6,036,361	A	3/2000	Gregory et al.	
6,045,257	A	4/2000	Pompei et al.	
6,047,205	A	4/2000	Pompei	
6,048,902	A	4/2000	Lebwohl et al.	
6,056,435	A	5/2000	Pompei	
6,059,452	A	5/2000	Smith et al.	
6,068,399	A	5/2000	Tseng	
6,074,090	A	6/2000	Chen	
6,146,015	A	11/2000	Weiss	
6,179,785	B1	1/2001	Martinosky et al.	600/549
6,219,573	B1	4/2001	Pompei	
6,220,750	B1	4/2001	Palti	
6,241,384	B1	6/2001	Pompei et al.	
6,250,802	B1	6/2001	Dotan	
6,257,758	B1	7/2001	Culbertson	
6,280,397	B1	8/2001	Yarden et al.	
6,283,915	B1	9/2001	Aceti et al.	600/300
6,292,685	B1	9/2001	Pompei	
6,299,347	B1	10/2001	Pompei	
6,319,206	B1	11/2001	Pompei et al.	
6,402,371	B2	6/2002	Pompei et al.	
6,419,388	B2	7/2002	Lee	
6,450,970	B1	9/2002	Mahler et al.	600/549
6,499,877	B2	12/2002	Pompei	
6,521,353	B1*	2/2003	Majagi et al.	428/565
6,522,912	B1	2/2003	Nakatani et al.	
6,547,744	B1	4/2003	Pompei et al.	
6,556,852	B1	4/2003	Schulze et al.	600/32
6,629,776	B2	10/2003	Bell et al.	
6,641,301	B2	11/2003	Pompei	
6,794,990	B2	9/2004	Tseng	
6,827,487	B2	12/2004	Baumbach	
6,830,549	B2	12/2004	Bui et al.	
6,839,651	B2	1/2005	Lantz et al.	
6,854,882	B2	2/2005	Chen	
2001/0025151	A1	9/2001	Kimball et al.	
2002/0010390	A1	1/2002	Guice et al.	
2002/0114375	A1	8/2002	Pompei	
2002/0138017	A1*	9/2002	Bui et al.	600/537
2002/0150143	A1	10/2002	Tokita et al.	
2003/0139686	A1*	7/2003	Rubinstein	600/549
2004/0025871	A1	2/2004	Davies	
2004/0076215	A1*	4/2004	Baumbach	374/29
2005/0043631	A1	2/2005	Fraden	
2005/0211436	A1*	9/2005	Fripp et al.	166/302

FOREIGN PATENT DOCUMENTS

WO 2006009585 A1 1/2006

OTHER PUBLICATIONS

U.S. Patent and Trademark Office, Office Action in U.S. Appl. No. 10/870,654 filed Mar. 27, 2007.

* cited by examiner

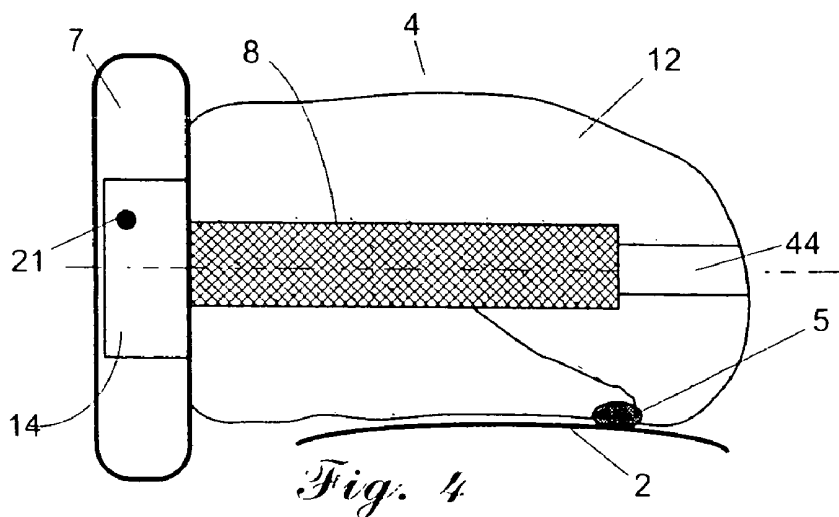
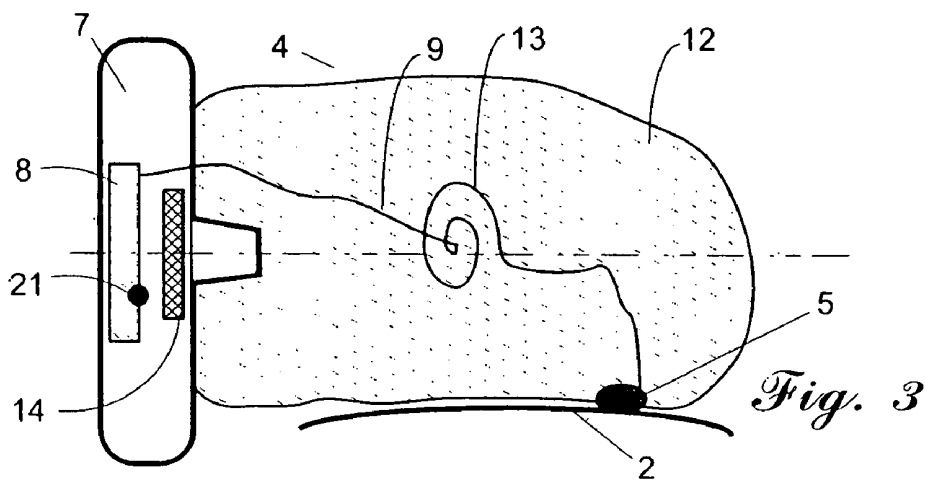

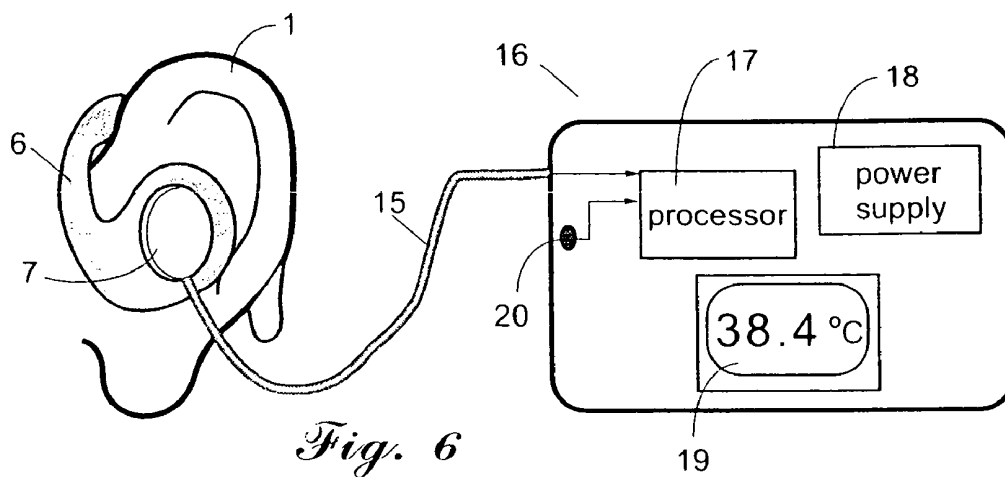
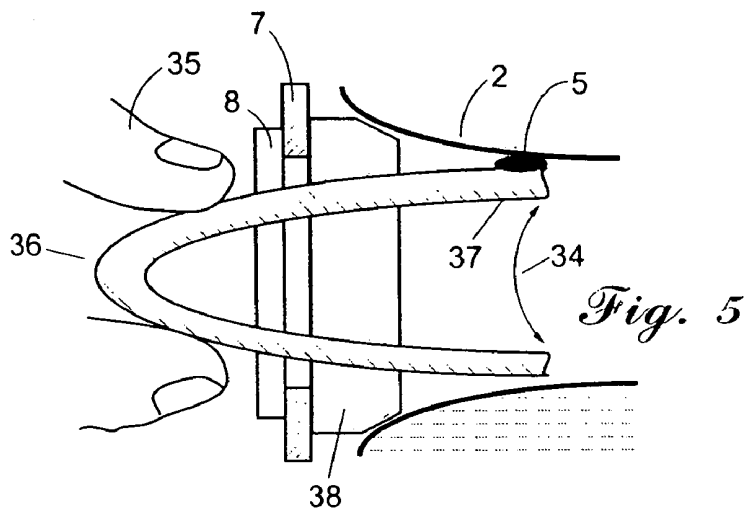

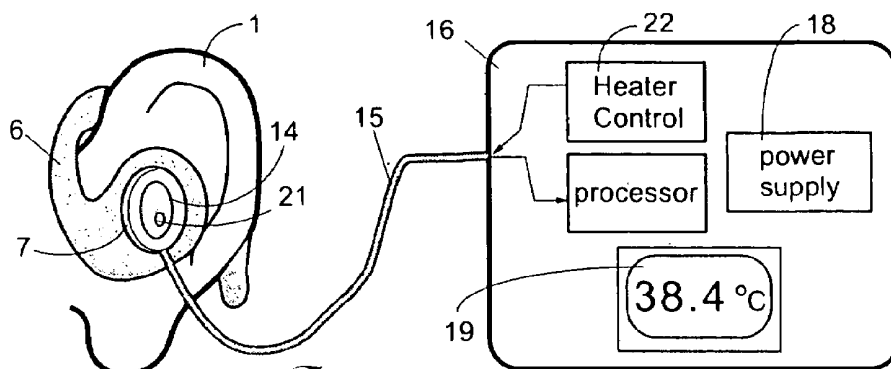

Fig. 7

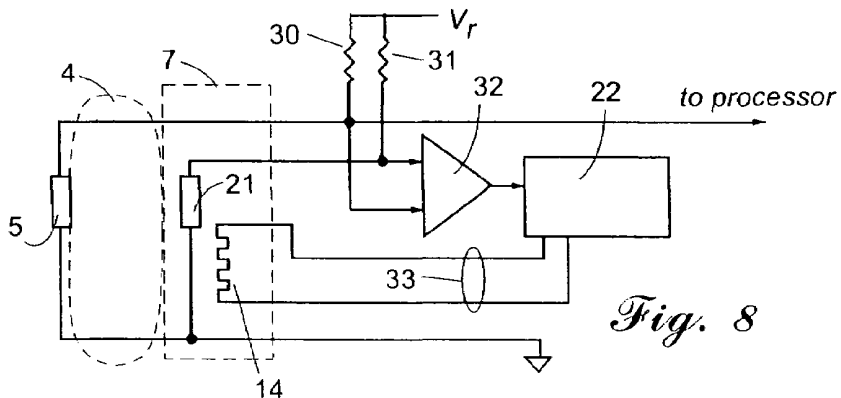

Fig. 8

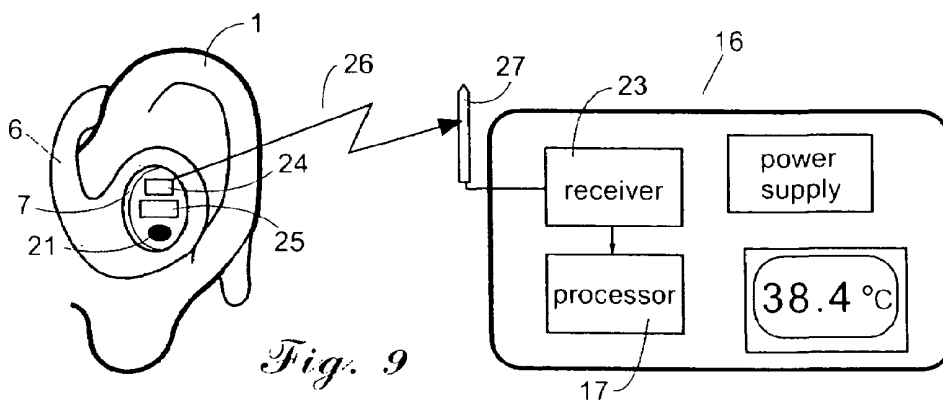
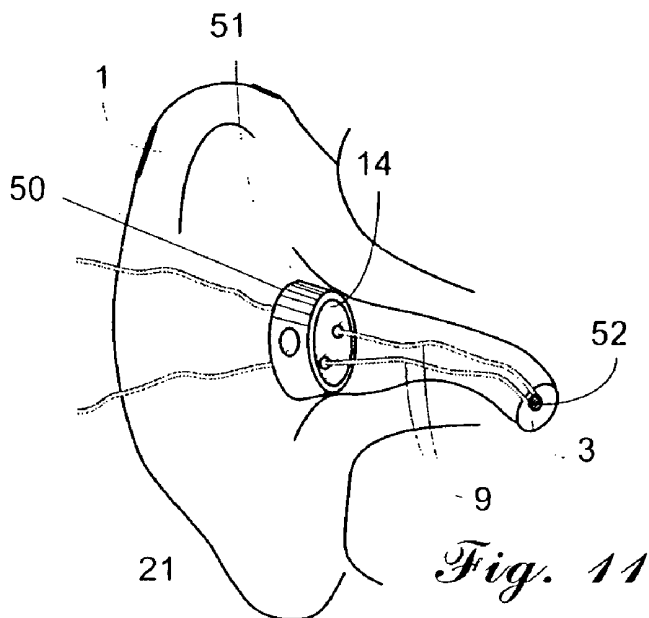
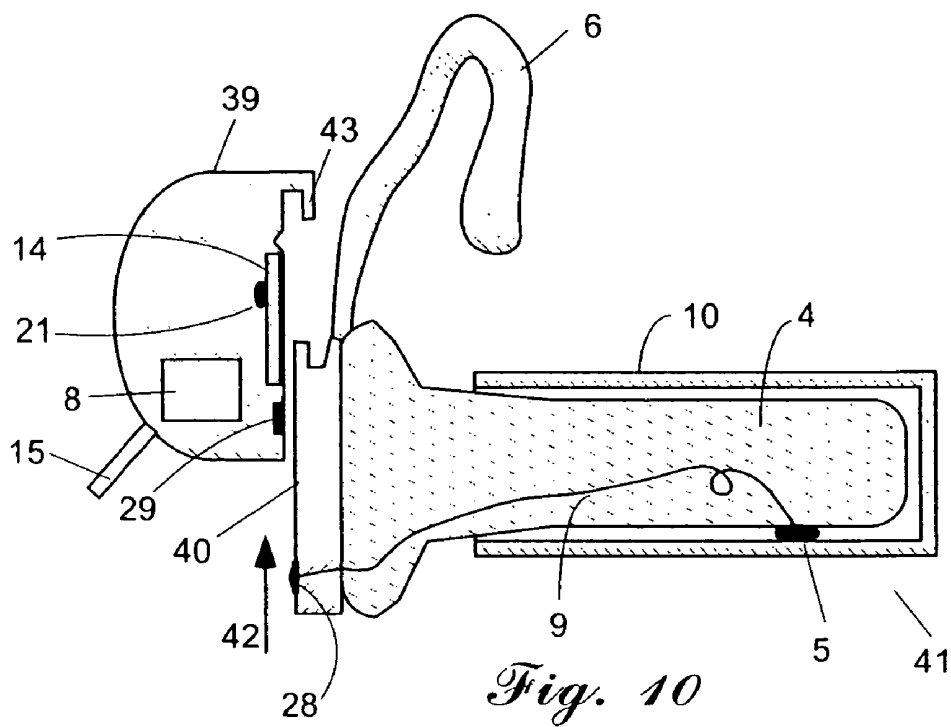
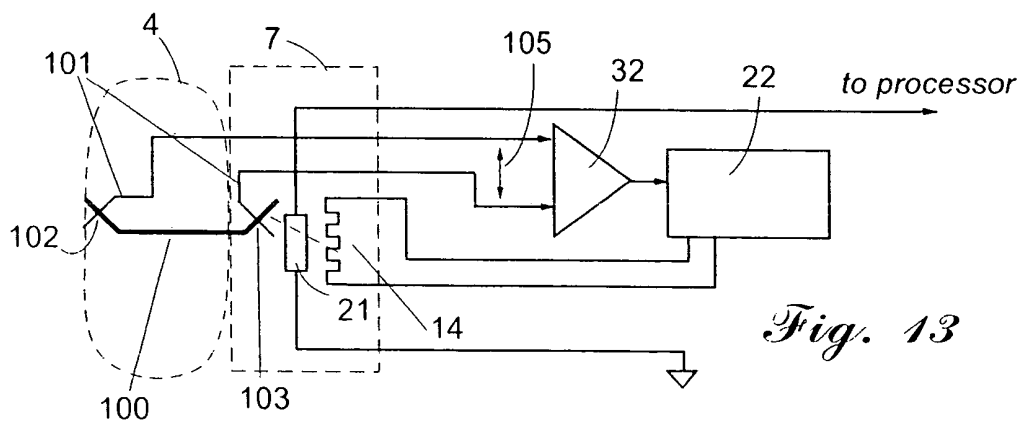
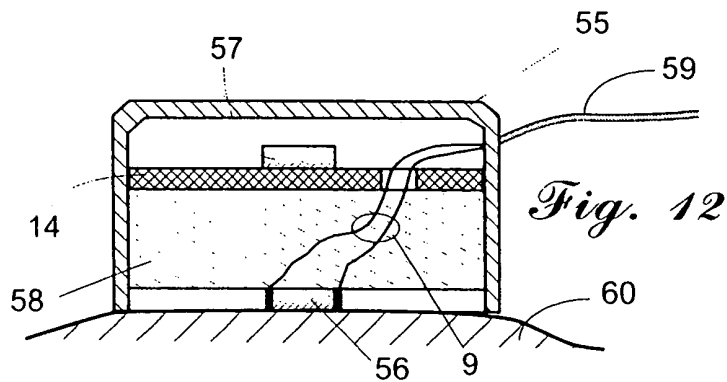

Fig. 9





EAR TEMPERATURE MONITOR AND METHOD OF TEMPERATURE MEASUREMENT

This application is a continuation of application Ser. No. 09/927,179, filed on Aug. 8, 2001 (now U.S. Pat. No. 6,773,405), which claims the benefit of U.S. provisional application Ser. No. 60/233,104, filed on Sep. 15, 2000 (abandoned), the disclosures of which are fully incorporated herein by reference.

FIELD OF THE INVENTION

This invention relates to a method of monitoring temperature of a human body and devices for achieving same and, more particularly, to such a method and device which monitors the internal core temperature of a person undergoing continuous medical observation.

DESCRIPTION OF PRIOR ART

Frequently, during surgical and other medical procedures related to humans and animals, there is a need for continuous monitoring of the body core temperature. Core temperature here means temperature of blood flowing around the brain and other vital internal organs. It has been recognized long time ago that the core temperature is an accurate parameter for assessing the physiological functions and metabolic activity of a body.

Traditionally, there are several known devices for continuous assessing body temperature of a patient. All these devices primarily differ by the measurement site. Specifically, they are 1) an esophageal probe, 2) a rectal probe, 3) skin temperature probes, and 4) an intermittent instant ear thermometers, often called tympanic. The last device presently can not provide a continuous monitoring. The first two devices yield accuracy well acceptable for the diagnostic and monitoring purposes and account for the majority of present temperature recordings. These traditional devices are invasive, may require sterile probes (esophageal), often inconvenient and, as a rule, not acceptable for patients outside the operating rooms. A skin temperature monitoring is used sporadically as it is more influenced by the ambient temperature. The need for an easy, inexpensive, accurate, and comfortable way of continuous temperature monitoring is substantial.

It has been recognized long time ago that the tympanic region of the ear canal follows the body core temperature with high fidelity. The region includes the tympanic membrane and the adjacent walls of the ear canal. This premise has been the basis for the tympanic thermometers, including both the contact and non-contact (infrared) types. An example of a contact transducer is a miniature thermistor (produced, for example, by Vital Signs, Inc.) that is positioned directly on the surface of a tympanic membrane with the connecting wires secured inside the ear canal. Generally, this can be performed only on an anesthetized patient with a risk of damaging the tympanic membrane and thus is rarely used in medical practice. Another example is a contact temperature transducer that is incorporated into an ear plug (U.S. Pat. No. 3,274,994). Examples of continuous noncontact optical infrared probes are given in U.S. Pat. Nos. 3,282,106 and 3,581,570.

Contact detectors are much simpler than noncontact, but they both suffer from the same effect—difficulty of a reliable placement inside the ear canal. Placement of a contact temperature transducer inside the ear canal without a reliable

securing of it at any specific position may cause a high inaccuracy in measurement, due to unpredictable effects of the ambient temperature and placement technique of the probe. An attempt to incorporate a temperature transducer into an ear plug similar to a hearing aid device is exemplified by U.S. Pat. No. 5,333,622 issued to Casali, et al. Yet, the teaching does not resolve the accuracy problem due to heat loss. Besides, such a probe requires an individual tailoring of its shape. It should be noted that besides a temperature measurement, there are some other types of measurements that may require a secure adaptive positioning of a transducer inside a body cavity.

Therefore, it is a goal of this invention to produce a sensing device that can be positioned securely and reliably in a body cavity;

Another goal of the invention is to make an ear temperature transducer with a contact probe that is automatically secured at an ear canal wall;

It is another goal of this invention to produce an ear temperature transducer that tracks the core temperature with high fidelity;

It is another goal of this invention to make an ear temperature transducer that is less influenced by the ambient temperature;

It is another goal to provide an ear temperature transducer that doesn't cause a discomfort for a patient and can remain in the ear canal for a prolonged time;

SUMMARY OF THE INVENTION

The goals of this invention is achieved by the novel ear temperature detector. The detector is comprised of an ear plug carrying the temperature sensing device wherein the sensing device is characterized by its increased thermal coupling to a wall of an ear canal and decreased coupling to the environment. This is attained by pre-shaping the plug into a smaller size and allowing to change its shape upon the insertion, until the sensing device is clamped between the plug and the skin. To correct for a thermal gradient across the ear plug, the plug has low thermal conductivity and its external temperature is monitored. Alternatively, temperature of the external portion of the plug is actively controlled by a heater attached to the plug. The heater forms a thermal shield around the temperature sensing device, thus negating a thermal gradient across the plug.

BRIEF DESCRIPTION OF DRAWINGS

FIG. 1 shows a temperature detector inserted into an ear and secured on a helix.

FIG. 2 is a cross-sectional view of an ear temperature detector in a storage state

FIG. 3 is a cross-sectional view of a temperature detector in expanded state

FIG. 4 is a temperature detector with the electronic module inside the plug

FIG. 5 is a fork version of an ear plug

FIG. 6 shows a block diagram of a temperature monitor

FIG. 7 depicts a block diagram of a temperature monitor with an additional heater

FIG. 8 is an electrical circuit diagram of a controlled heater with thermistor sensors.

FIG. 9 is a radio telemetry version of a temperature monitor

FIG. 10 depicts a practical assembly of an ear temperature detector

FIG. 11 shows a tympanic sensor with a compensating heater

FIG. 12 illustrates a cross-sectional view of a surface temperature sensor

FIG. 13 is an electrical circuit diagram of a controlled heater with a thermocouple sensor

DESCRIPTION OF THE PREFERRED EMBODIMENTS

The present invention describes a device and method for obtaining information from a body cavity. At least three essential elements are required for this invention to work: a temperature transducer, a thermal insulator, and an external temperature sensor.

A preferred embodiment is illustrated herewith by showing how this can be accomplished with improved accuracy when the information is temperature and the body cavity is an ear canal of a human or other animal. The major task for accomplishing the stated goals is to increase a thermal coupling between the ear canal walls and a temperature transducer, while minimizing such coupling to the external environment. FIG. 1 illustrates an ear plug 4 that is inserted into ear 1, but not reaching the tympanic membrane 3. Temperature transducer 5 is clamped between plug 4 and ear canal walls 2. The transducer is connected to the electronic module 8 via wires 9. There may be more than one transducer attached to the plug, but for the preferred embodiment just one is a sufficient example. The module is positioned in the external supporting disk 7 that contains external temperature sensor 21. The entire assembly may be secured on ear 1 by carrier clamp 6 that has shape suitable for encircling the helix of an ear. Naturally, other conventional methods of securing may work as well. Since the ear canal wall temperature is close to that of tympanic membrane 3, it is assumed that transducer 5 can monitor the tympanic temperature, unless plug 4 and wires 9 sink a significant portion of thermal energy from the transducer, resulting in erroneous temperature measurement. The position of transducer 5 inside the ear canal has to be consistent and always between plug 4 and walls 2. The output signal is measured via conductors 70.

To achieve the desired results, transducer 5 is attached to a specific portion of plug 4. That portion preferably should be at the distal end of the plug that would be inserted into a body cavity, such as an ear canal. FIG. 2 shows plug 4 in a storage stage, that is, before it is inserted into an ear. The plug has two ends—base 11 and tip 12. The base is attached to an external enclosure. The enclosure is in form of disk 7 that may have a protruding pin 45 inside the plug for better mechanical and thermal coupling between disk 7 and plug 4. In a storage state or just prior the insertion into the ear canal, tip 12 is compressed to a size that is smaller than the inner dimension of the ear canal. To retain such reduced shape for a long time, the tip may be inserted into storage sleeve 10 that provides a constraining compression. The sleeve may be a plastic tube. Plug 4 is fabricated of pliable material that may be collapsed when squashed (compressed) and recover its original shape (expand) when external pressure is released. The plug serves as a thermal insulator. Its thermal conductivity should be minimal, thus foams are the best choice of the material. An example of such a material is water-born hydrophilic foam. The foam should not have a significant dimensional memory so that it returns to the original expanded shape after prolonged storage in the collapsed (compressed) shape.

For a better thermal speed response, temperature transducer 5 is secured on the surface of tip 12. The transducer should have a small size and may be of any suitable design—thermistor, thermocouple, semiconductor, etc. Wires 9 should sink out as little heat as possible, thus they need to be fabricated as thin as practical and should have an extended length inside or on the surface of plug 4. To increase the length, wires 9 may be formed into loop 13 that is positioned between transducer 5 and electronic module 8, regardless of position of the module (explained below).

Before insertion of the plug into an ear canal, sleeve 10 is removed and discarded. Shape of tip 12 slowly returns to that which was prefabricated before the installation of sleeve 10. Alternatively, tip 12 may be squashed by an operator just before the insertion. The rate of the shape recovery should be sufficiently slow to allow enough time for the insertion of plug 4 into an ear canal. Practically, the shape recovery time should be greater than 3 seconds. After the collapsed tip 12 is inserted into an ear canal, its continuous shape recovery forces plug 4 to conform with the shape of an ear canal. The expansion of plug 4 stops when it completely fills up the adjacent ear canal volume. This allows transducer 5 to be forcibly compressed against ear canal wall 2, while still being electrically connected to electronic module 8 via wires 9, as shown in FIG. 1.

Electronic module 8 may contain the amplifier, power supply, signal conditioner, transmitter and other components, or it may be a simple connecting device. In some embodiments, module 8 may be positioned directly inside plug 4 as shown in FIG. 4. In this case, the size of module 8 should be small enough to allow compression of tip 12 before the insertion. Module 8 may be used for many other purposes, in addition to or instead of measuring temperature. An example is generating sound. In that case, opening 44 in plug 4 may be required for better sound coupling to the tympanic membrane.

It should be stressed that an ear canal is just an example of an application and the identical concept of an expandable plug with an attached transducer can be used for producing an insert for other body cavities, for example, nasal. Further, there may be other than temperature transducers attached to the plug, for example acoustic.

Another possible embodiment of plug 4 is shown in FIG. 5 where the plug is made in shape of flexible fork 36 having a spring action. The end of the fork is squeezed by fingers 35 before the insertion and let go after. The fork has arm 37 that carries transducer 5. After the fork is released, it expands so that its arm 37 compresses transducer 5 against ear canal wall 2. To improve thermal separation of transducer 5 from the outside, the fork may be supplied with insulator 38. Other components, like the wires, the loop, the electronic module, etc. are not shown in FIG. 5.

The expanded plug 4 performs an important function—positioning and clamping transducer 5 on an ear canal wall surface. The other critical function—minimizing effects of the ambient temperature may be accomplished by at least two methods. One method is a mathematical correction and the other is an active compensation. The method of a mathematical correction of an error is performed by the use of an additional ambient temperature sensor that is positioned either directly on disk 7 as external sensor 21 (FIGS. 2 and 3), or in/on the external monitor 16 as ambient sensor 20 (FIG. 6). Note that for this method, heater 14 is not required and only one sensing device—either ambient sensor 20 or external sensor 21 is needed. Disk 7 of an ear device is connected to monitor 16 via cable 15 (FIGS. 6 and 7). Monitor 16 may contain signal processor 17, power

supply 18, display 19 and other components. Ambient sensor's 20 or external sensor's 21 signal is processed and used to correct for errors in the ear temperature measurement. The degree of correction needs to be established experimentally for a particular plug design. The corrected body temperature t_b may be determined through a temperature gradient, for example, as:

$$t_b = t_s + \mu(t_s - t_a) \quad (1)$$

where μ is the experimental constant, t_a is the temperature measured by ambient sensor 20 or external sensor 21 and t_s is the reading of ear temperature transducer 5.

The above method of error correction, however, has it's limitations. One is the uncertainty in the value of constant μ . Another limitation is the use of ambient sensor 20. Having ambient sensor 20 placed at monitor 16, makes the mathematical correction less effective when, for example, the patient is laying on the ear which is being monitored and thus having the external ear temperature significantly different from that of ambient monitored by sensor 20.

A more effective method of the error reduction is an active heat loss compensation that is shown in FIG. 7. It is based on forming a thermal shield around temperature transducer 5. Disk 7 carries heater 14 and external temperature sensor 21, positioned on or near heater 14 with a good thermal coupling between them. Note that disk 7 is located outside of the ear canal, directly at it's opening. Heater 14 also may be seen in FIGS. 2, 3 and 4. The heater controller, that is positioned either inside disk 7 or in monitor 16, as shown in FIG. 7, receives signal from external sensor 21 and controls temperature of heater 14 to a required level, that should be close to the actual body temperature as monitored by transducer 5. Thus, heater 14 minimizes temperature gradient between temperature transducer 5 and heater 14. It acts as a thermal shield between temperature transducer 5 and the environment. Circuit diagram of FIG. 8 further illustrates this method. A reference point for the heater control is provided by temperature transducer 5 positioned inside the ear canal and compressed by plug 4 to the ear canal wall. Both temperature transducer 5 and external sensor 21 are connected to the Wheatstone bridge circuit with two pull-up resistors 30 and 31. Thermal coupling between transducer 5 and the ear canal walls needs to be much better than between temperature transducer 5 and the external components, that is, external sensor 21 and heater 14. This is primarily accomplished by the use of thermally insulating plug 4. An excessive thermal coupling between temperature transducer 5 and external sensor 21 may result in undesirable instability of the control circuit. Error amplifier 32 compares the output signals from temperature transducer 5 and external sensor 21 and controls heater controller 22, that in turn, via conductors 33, adjusts electric power to heater 14. This circuit maintains temperature of heater 14 close to that of temperature transducer 5. This results in a negligible heat transfer through plug 4 and elimination of the error in temperature measured by temperature transducer 5. Turning again to Eq. 1, we can see that with the active heating of the above thermal shield method, temperatures at both sides of plug 4 equalize: $t_a \approx t_s$, and thus value of μ become irrelevant, so that $t_b = t_s$. In other words, transducer 5 now directly measures temperature of the body with no influence of the ambient temperature.

As a variant of FIG. 8, FIG. 13 illustrates use of a thermocouple temperature transducer having two dissimilar conductors 100 and 101. A thermocouple has two junctions, hot junction 102 and cold junction 103. Hot junction 102 is positioned inside the body cavity at one end of plug 4, while

cold junction 103 is thermally attached to heater 14 and external sensor 21 near the other end of plug 4.

Heater controller 22 receives signal from thermocouple amplifier 32 and operates such as to bring thermocouple output voltage 105 close to zero. This will establish a minimal thermal gradient across plug 4 so that external sensor 21 indicates the internal body temperature.

The use of cable 15 as shown in FIGS. 6 and 7 may not be desirable, as it may restrict movement of a patient. The cable can be eliminated if disk 7 carries transmitter 24 and power source 25, as illustrated in FIG. 9. Accordingly, monitor 18 needs to contain antenna 27 and receiver 23. The link between the patient and the monitor may be via radio waves 26, or optical (both involve electromagnetic radiation). Alternatively, transmitter 24 and/or power source 25 can be located outside of disk 7, but in that case, an intermediate packaging for these components (not shown) would be required. It should be noted, that in the wireless communication with the monitor, method of a passive error correction is preferable, so that transmitter 24 will send information concerning blot transducer 5 and external sensor 21.

A practical way to produce an ear temperature monitoring device with a thermal shield is shown in FIG. 10. Reusable cup 39 may contain electronic module 8, cable 15, second contacts 29, heater 14, and external sensor 21. A detachable part is disposable insert 41 that contains plate 40, plug 4, and transducer 5 attached via wires 9 to first contacts 28. Before operation, insert 41 is moved in direction 42 to mate with cup 39. Both cup 39 and insert 41 are engaged and retained together during the temperature monitoring with the help of lock 43. Contacts 28 and 29 provide connection between wires 9 and electronic module 8. After the monitoring is completed, disposable insert 41 may be detached from cup 39 and discarded.

OTHER EMBODIMENTS

A thermal shield method similar to one shown in the preferred embodiment can be employed to reduce effects of the environment with other types of the medical temperature sensors. The general operating principle is basically the same as described above. FIG. 11 shows an example of a temperature transducer 52 that is directly attached to tympanic membrane 3 of ear 1. This embodiment does not necessarily require an expanding plug 4 that has been shown in the prior illustrations. Wires 9 pass through or near heating insert 50 that is inserted into ear opening 51. The heating insert contains external sensor 21 and thermally attached to it heater 14, whose temperature is controlled to approach that measured by transducer 52. As above, wires should be as thin as practical and heater 14 should be thermally de-coupled from transducer 52. Since the thermal gradient across wires 9 between transducer 52 and external sensor 21 becomes small, effects of the ambient temperature also become small, while the accuracy of measurement improves.

Another embodiment of the same thermal shield method is depicted in FIG. 12. This is a surface temperature measuring device that can measure a "deep" (subcutaneous) body temperature. The device is comprised of housing 55 secured to skin 60 or another surface of a subject, skin temperature sensor 56, heater 14, thermal insulator 58, second temperature sensor 57, wires 9, and cable 59. Housing 55 is formed from metal, as represented by the cross-section lines. Note that wires 9 pass through insulator 58 and through or near heater 14. Insulator 58 can be a body of

polymer foam or even an air gap. In operation, the temperature of second temperature sensor 57 is controlled to approach that of skin temperature sensor 56, by providing thermal energy to heater 14. This forms a thermal shield above skin temperature sensor 56 and minimizes heat loss from skin 60 and, subsequently, to an improved accuracy in temperature measurement. In most practical cases, for an acceptable accuracy, a typical temperature difference between sensors 56 and 57 should be no greater than 2° C. and preferably equal to zero.

While particular embodiments of the invention have been shown and described, it will be obvious to those skilled in the art that changes and modifications may be made without departing from the invention in its broader aspects, and, therefore, the aim in the appended claims is to cover all such changes and modifications as fall within the true spirit and scope of the invention.

The invention claimed is:

1. A method for continuous monitoring of the internal temperature of a subject, comprising:

positioning a first temperature sensor relative to a housing fabricated from metal having high thermal conductivity;

thermally attaching a heater to a second temperature sensor and to the housing, the second temperature sensor being positioned within the housing;

thermally insulating the first temperature sensor from the housing, the heater and the second temperature sensor;

securing the housing on a surface of the subject;

measuring the temperature of the surface using the first temperature sensor;

generating heat with the heater at a rate that minimizes a temperature gradient between the first and second temperature sensors; and

computing an internal temperature of the subject using signals from the first and second temperature sensors.

2. A method for continuous monitoring of the internal temperature of a subject, comprising:

positioning a first temperature sensor relative to a housing fabricated from metal having high thermal conductivity;

attaching a second temperature sensor to the housing;

thermally insulating the first temperature sensor from the housing and from the second temperature sensor;

securing the housing on a surface of the subject; measuring the temperature of the surface using the first temperature sensor; and

computing an internal temperature of the subject using signals from the first and second temperature sensors.

3. The method of claim 2, where computing the internal temperature further comprises determining a temperature gradient between the first and second temperature sensors and subsequently multiplying the gradient by an experimental constant.

4. A temperature sensing device for monitoring an internal temperature of a subject, comprising:

a housing configured to be in contact with a surface of the subject;

a first temperature sensor thermally insulated from said housing and configured to be thermally attached to the subject for detecting a surface temperature of the subject, wherein said housing is fabricated from metal having high thermal conductivity;

a second temperature sensor thermally coupled to said housing;

a thermal insulator positioned between said first temperature sensor and said second temperature sensor; and

an electronic module electronically connected to said first temperature sensor and said second temperature sensor.

5. The device of claim 4, further comprising a heater thermally coupled to said housing and electrically coupled to said electronic module.

6. The device of claim 4, wherein said thermal insulator further comprises an air gap between said first temperature sensor and said second temperature sensor.

7. The device of claim 4, wherein said electronic module further comprises a data transmitter for broadcasting responses of said first temperature sensor and said second temperature sensor.

8. The device of claim 4 further comprising an external monitor coupled to said electronic module and containing a power supply and signal processor for computation of the internal body temperature of the subject.

* * * * *

专利名称(译)	耳温监测仪和温度测量方法		
公开(公告)号	US7306565	公开(公告)日	2007-12-11
申请号	US10/887027	申请日	2004-07-08
[标]申请(专利权)人(译)	FRADEN JACOB 费利托RICHARD K		
申请(专利权)人(译)	FRADEN JACOB 费利托RICHARD K.		
当前申请(专利权)人(译)	高级MONITORS CORPORATION		
[标]发明人	FRADEN JACOB FERLITO RICHARD K		
发明人	FRADEN, JACOB FERLITO, RICHARD K.		
IPC分类号	A61B5/00 A61B5/01 G01K13/00 G01K13/02		
CPC分类号	A61B5/01 G01K13/022 G01K1/165 G01K13/002 A61B5/6817 A61B5/0002 A01K29/005		
优先权	60/233104 2000-09-15 US		
其他公开文献	US20040254497A1		
外部链接	Espacenet USPTO		

摘要(译)

连续的体芯温度监测器包括柔韧的耳塞，其符合耳道的形状并且包括夹在插头和耳道壁之间的温度传感器。插头的外表面连接到外部温度传感器和加热元件，该加热元件通过将温度传感器和加热元件之间的温度梯度保持接近零来补偿从耳道到环境的热量损失。

