



US 20120088984A1

(19) **United States**

(12) **Patent Application Publication**
Al-Ali et al.

(10) **Pub. No.: US 2012/0088984 A1**

(43) **Pub. Date: Apr. 12, 2012**

(54) **MAGNETIC ELECTRICAL CONNECTOR FOR PATIENT MONITORS**

Publication Classification

(76) Inventors: **Ammar Al-Ali**, San Juan Capistrano, CA (US); **Eric Karl Kinast**, Santa Ana, CA (US)

(51) **Int. Cl.**
A61B 5/04 (2006.01)
A61B 5/1455 (2006.01)
A61B 5/00 (2006.01)
(52) **U.S. Cl.** **600/301; 600/383; 600/324**

(21) Appl. No.: **13/246,768**

(57) **ABSTRACT**

(22) Filed: **Sep. 27, 2011**

Related U.S. Application Data

(60) Provisional application No. 61/387,426, filed on Sep. 28, 2010.

The present disclosure relates to an electrical connector for providing signal isolation between various components of a physiological monitoring system. In an embodiment, the electrical connector is placed between a sensor and associated monitoring system and includes a physical barrier and inductive components.

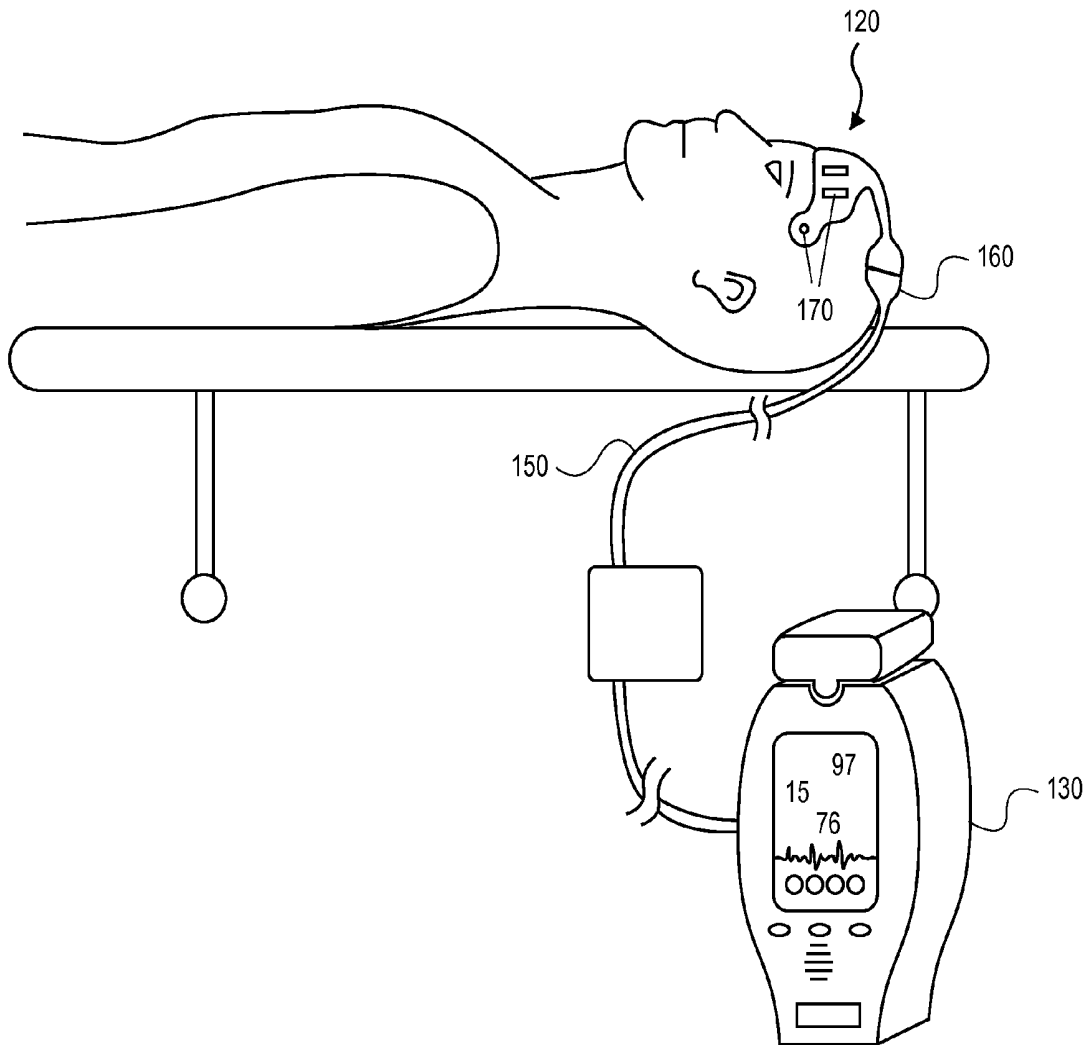
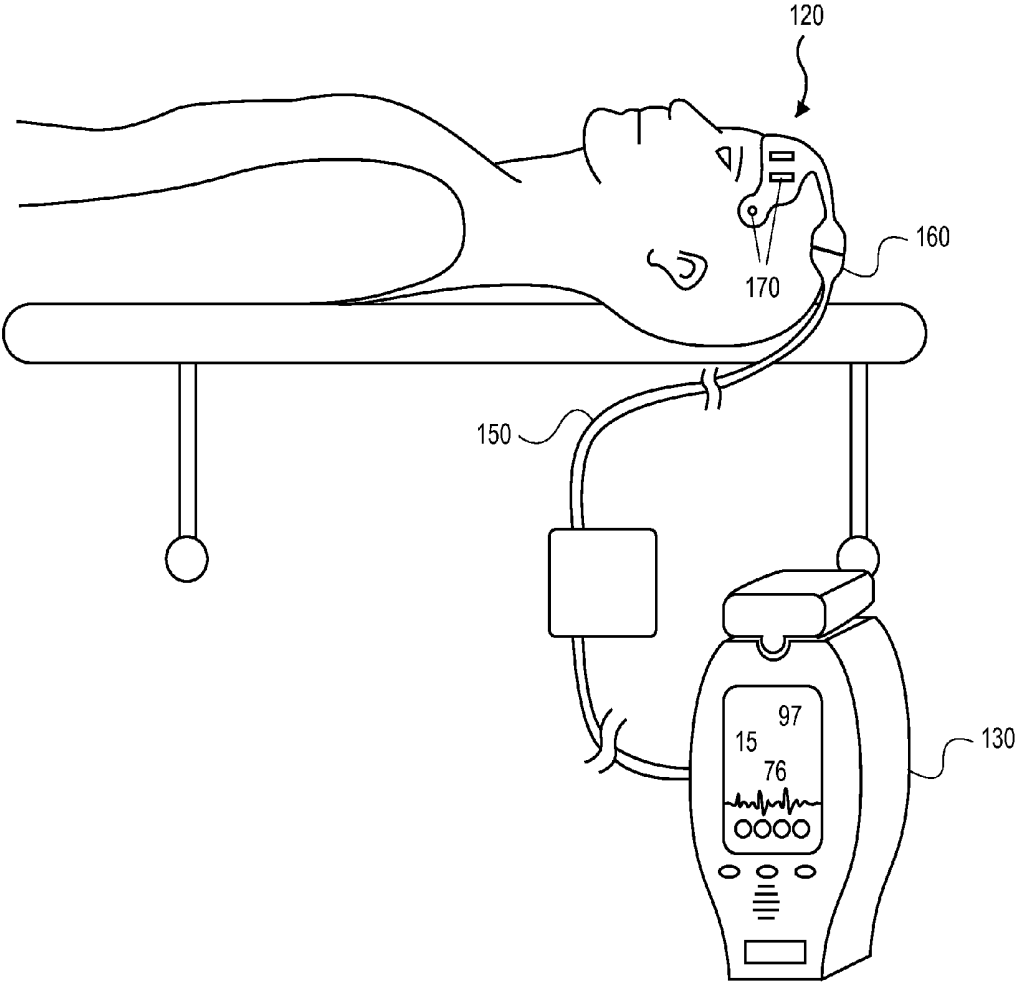

FIG. 1A



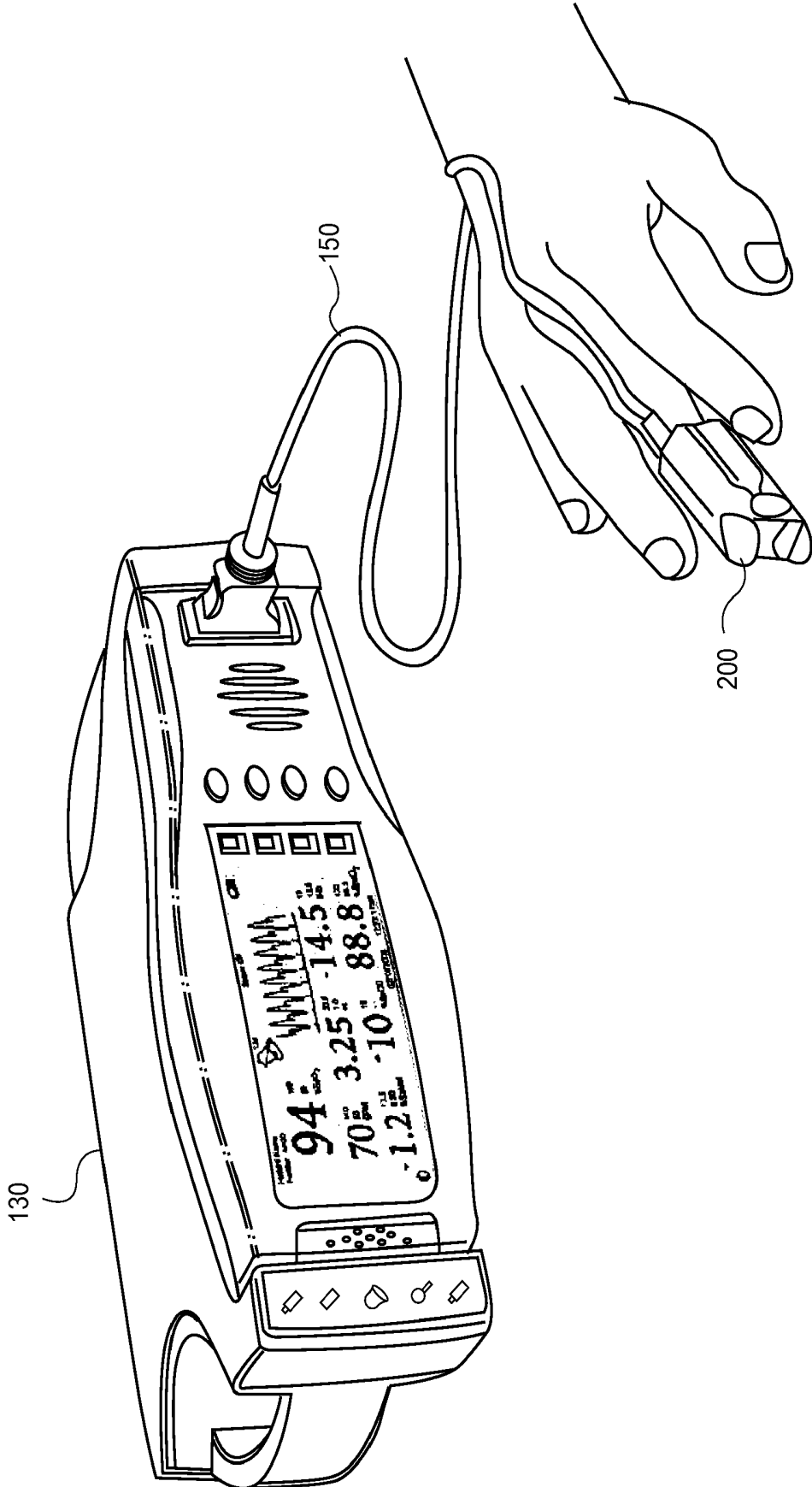

FIG. 1B

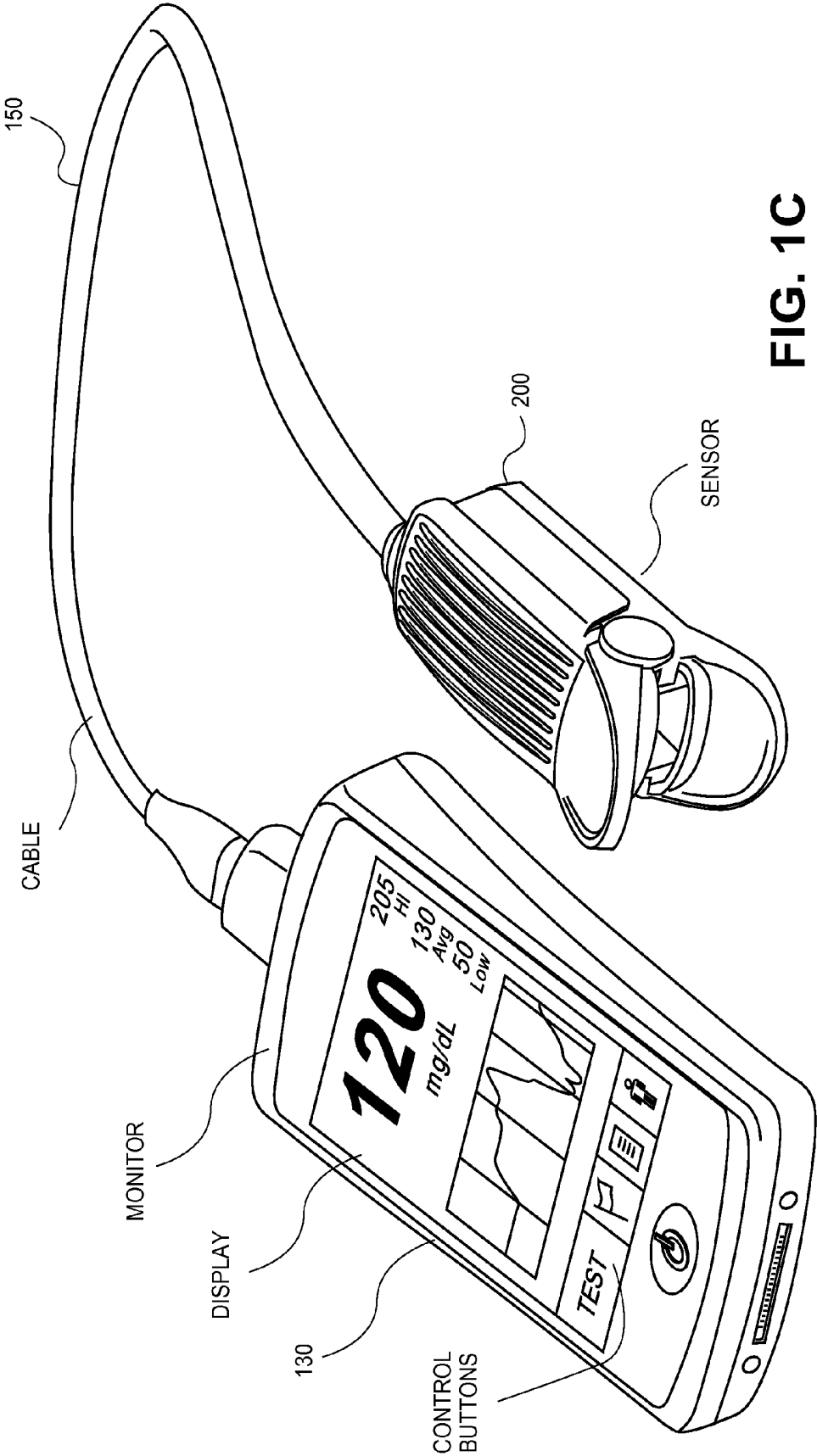

FIG. 1C

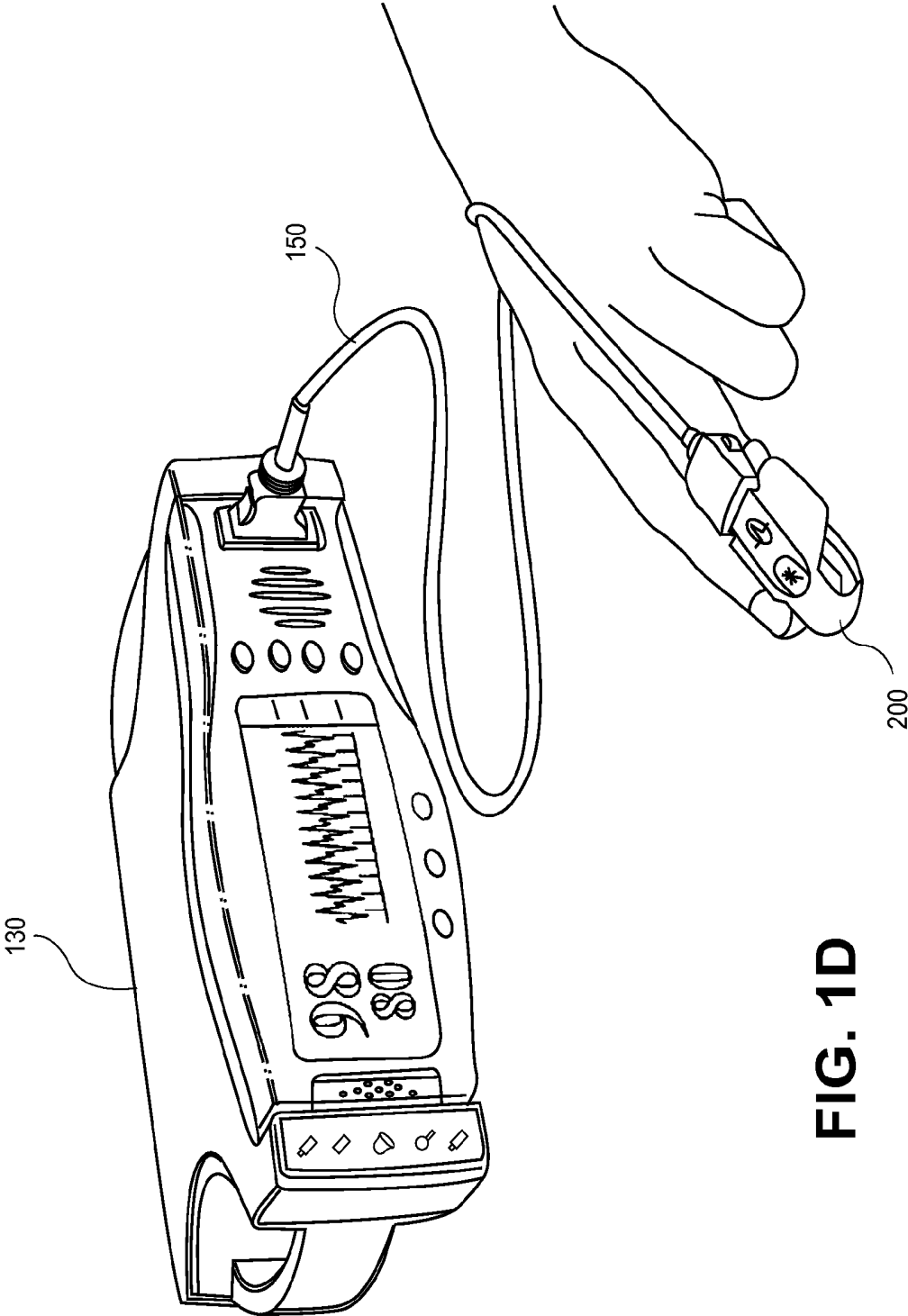

FIG. 1D

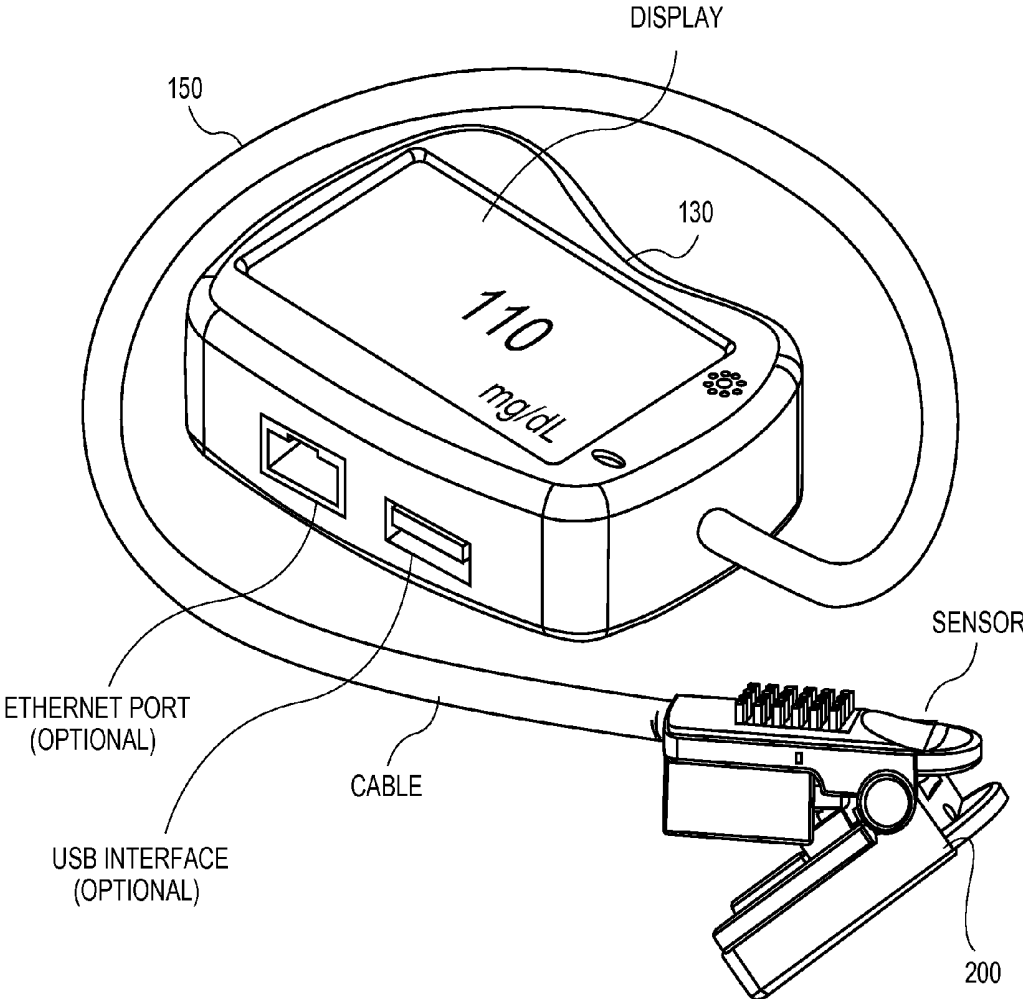

FIG. 1E

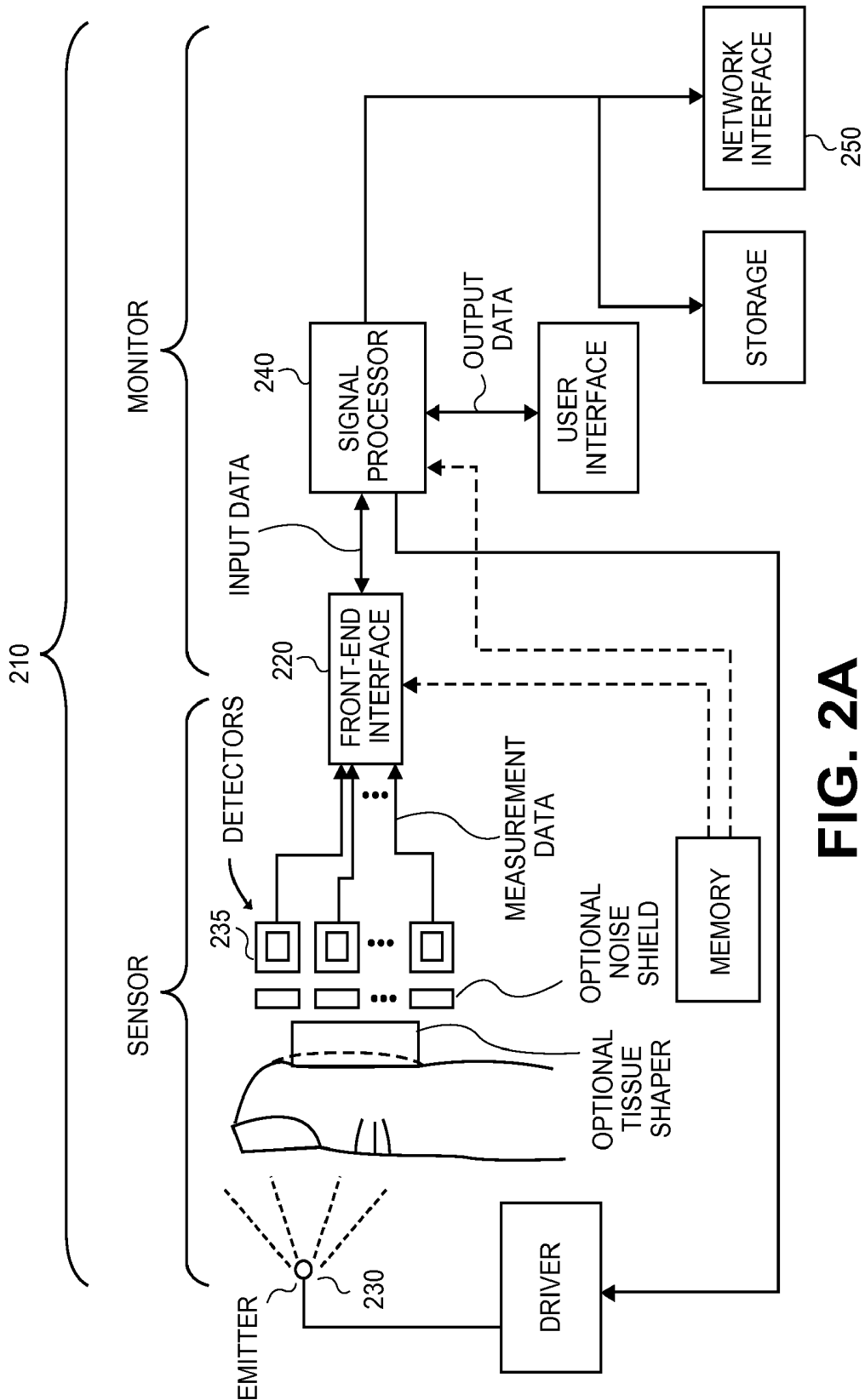

FIG. 2A

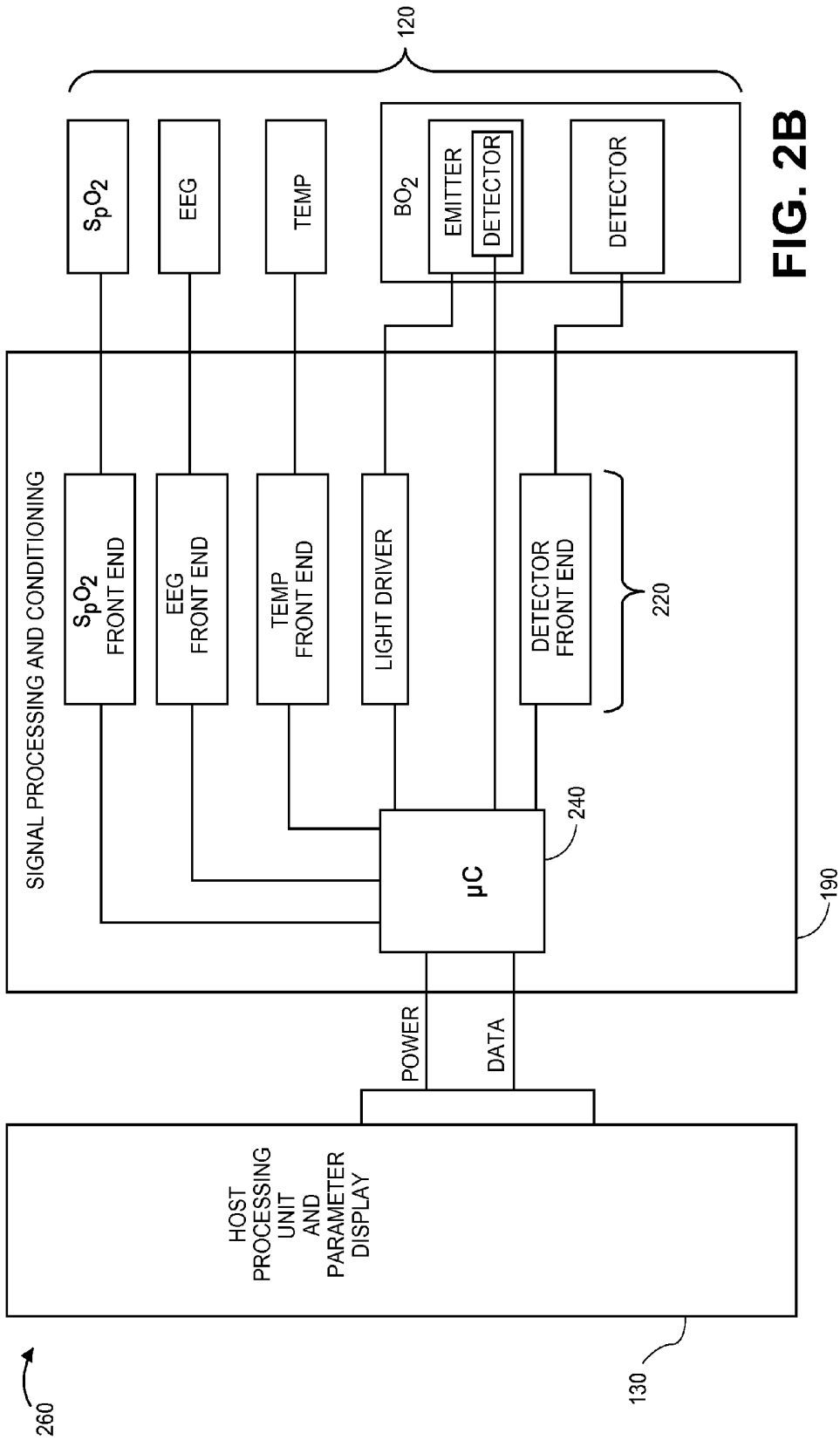

FIG. 2B

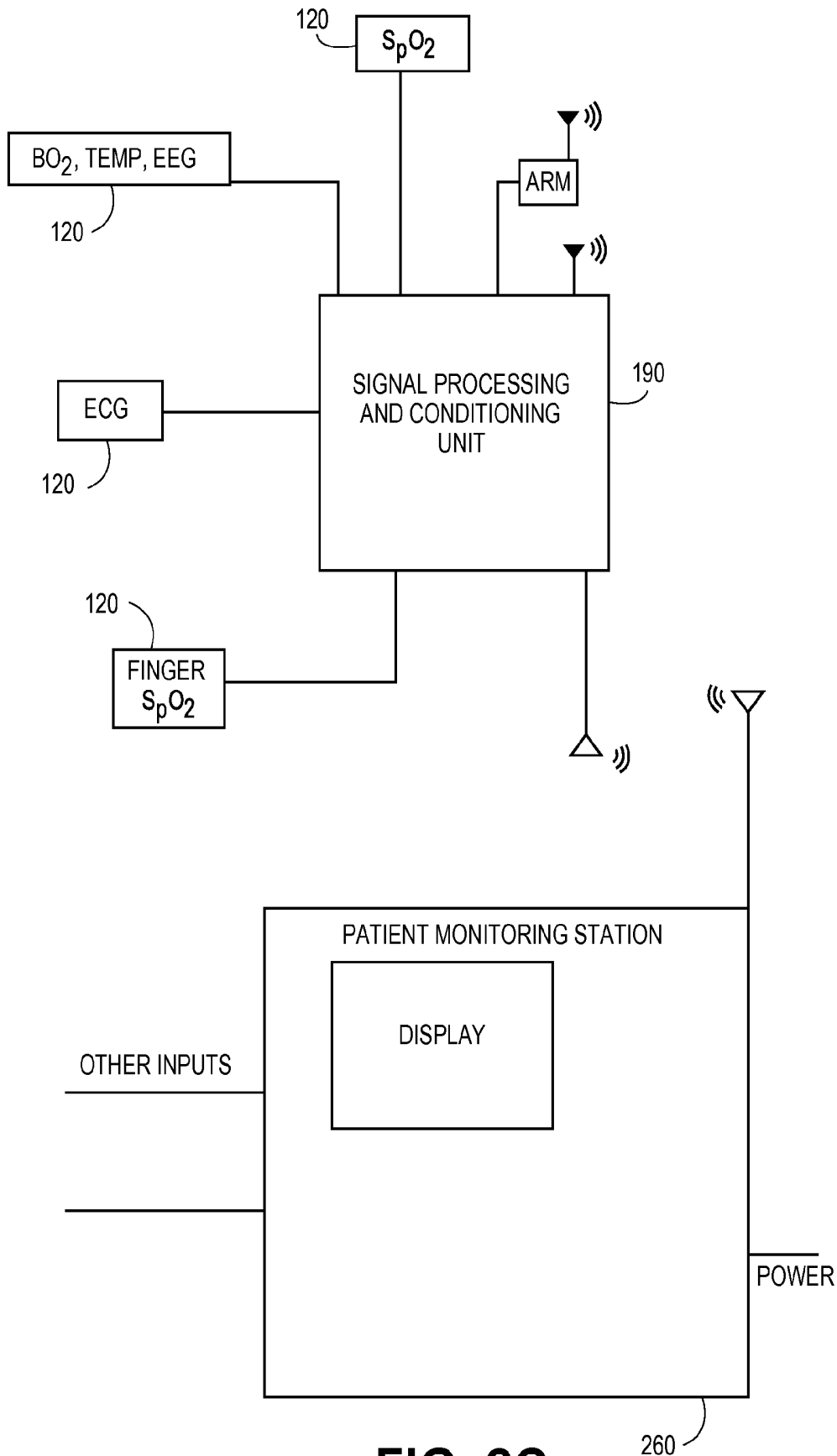

FIG. 2C

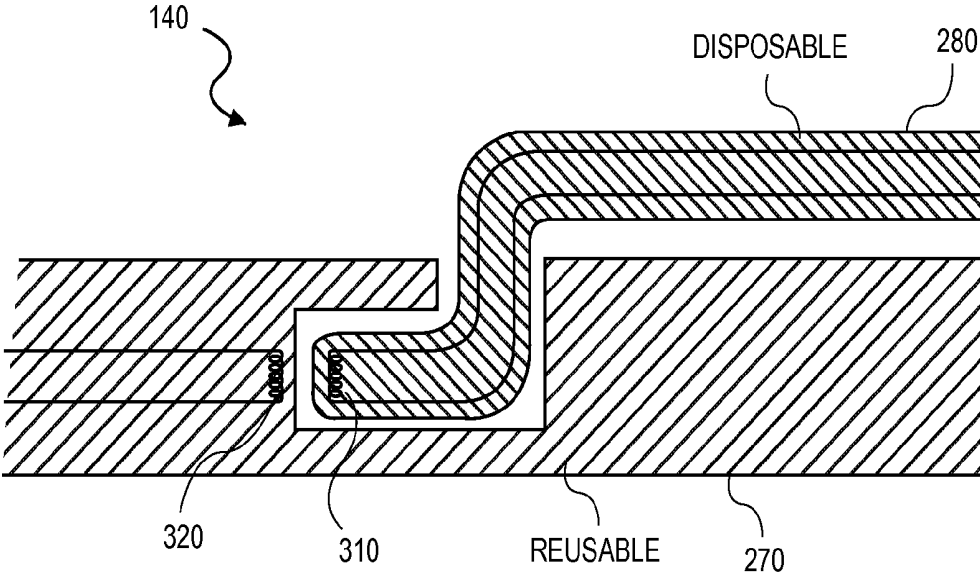

FIG. 3A

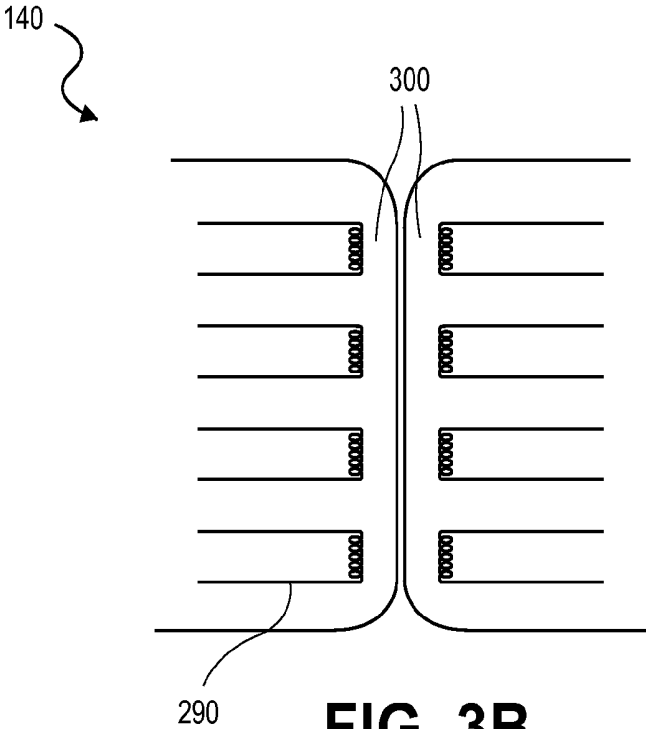
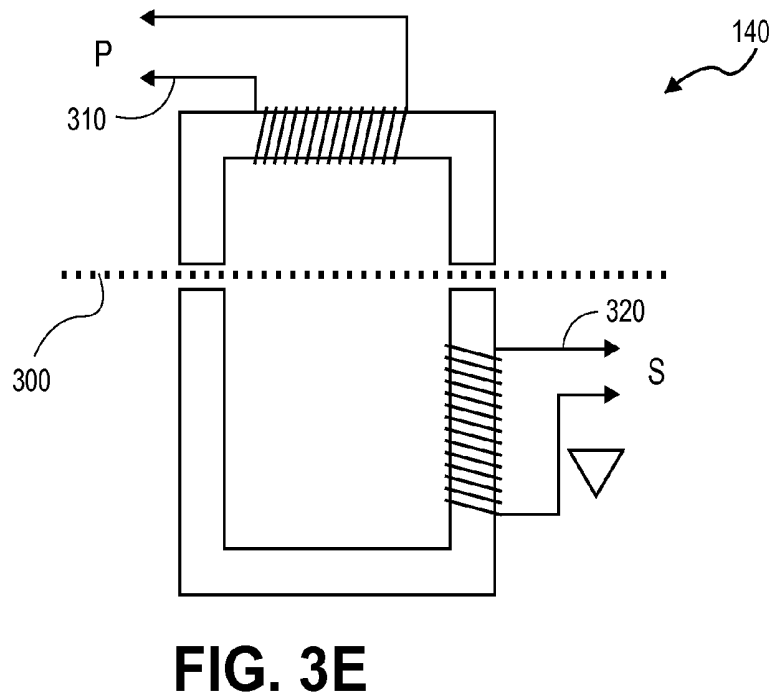
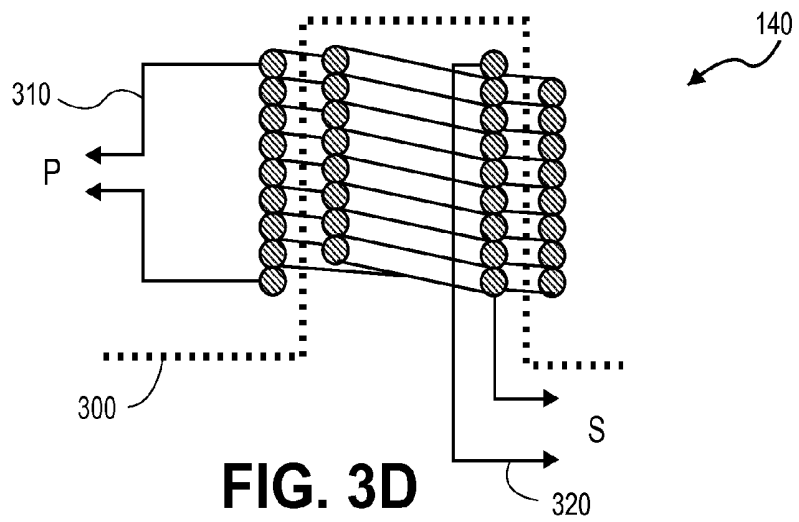
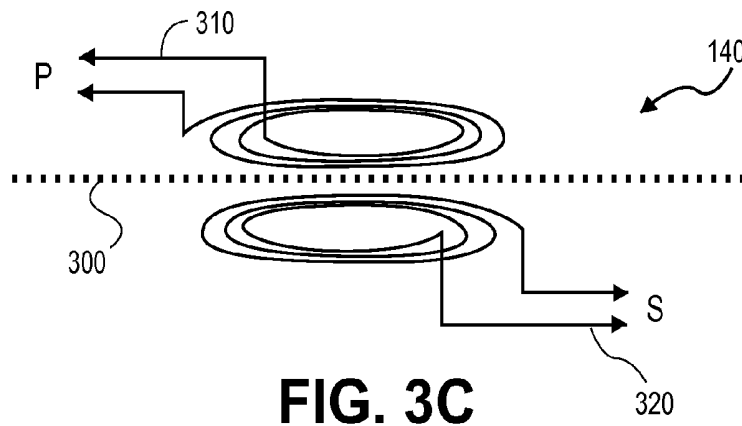

FIG. 3B



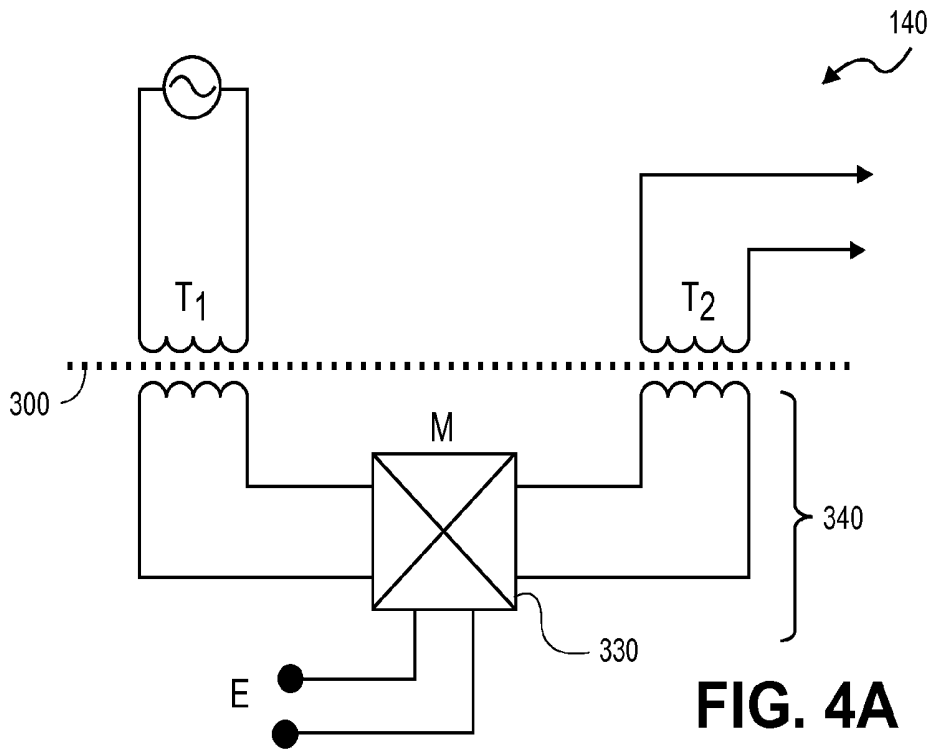

FIG. 4A

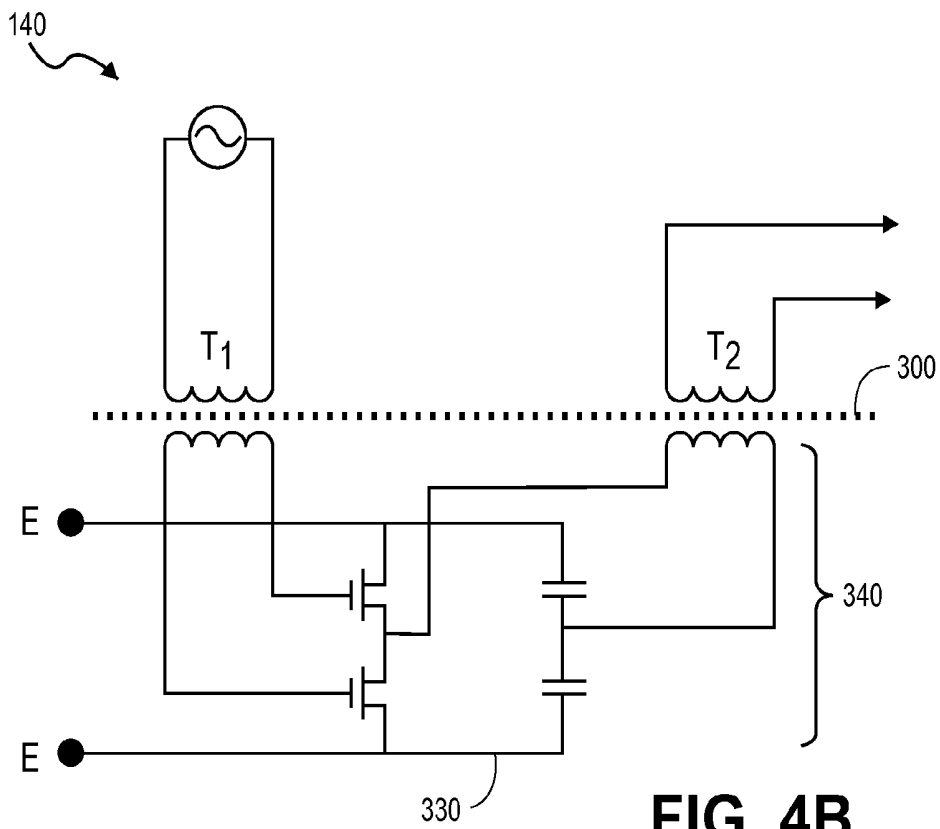

FIG. 4B

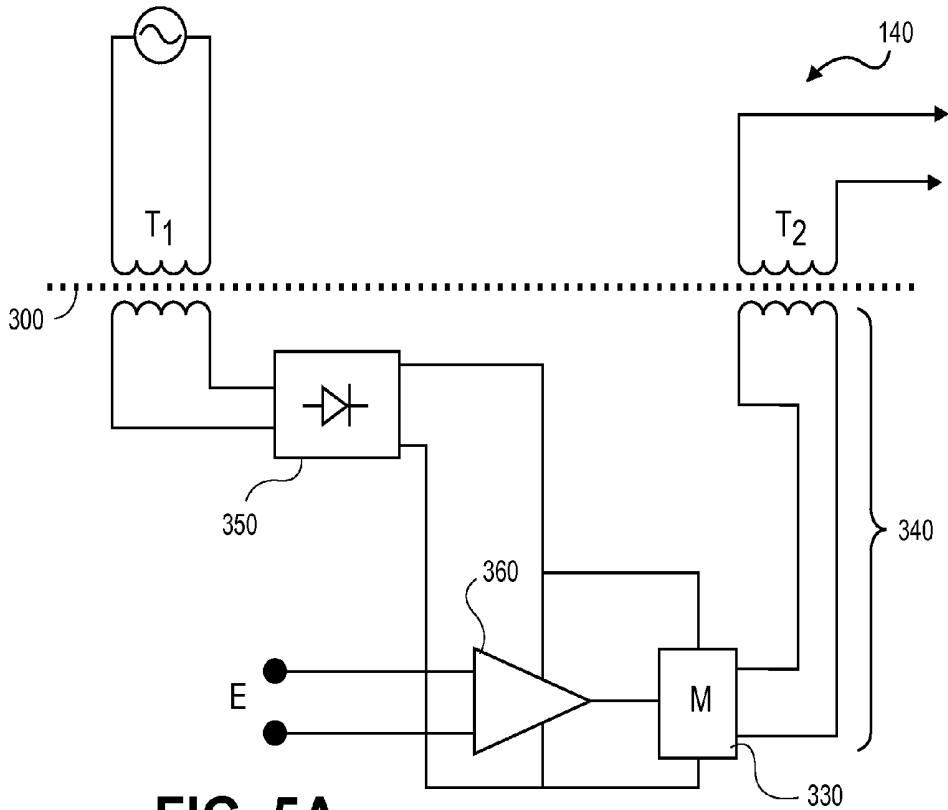

FIG. 5A

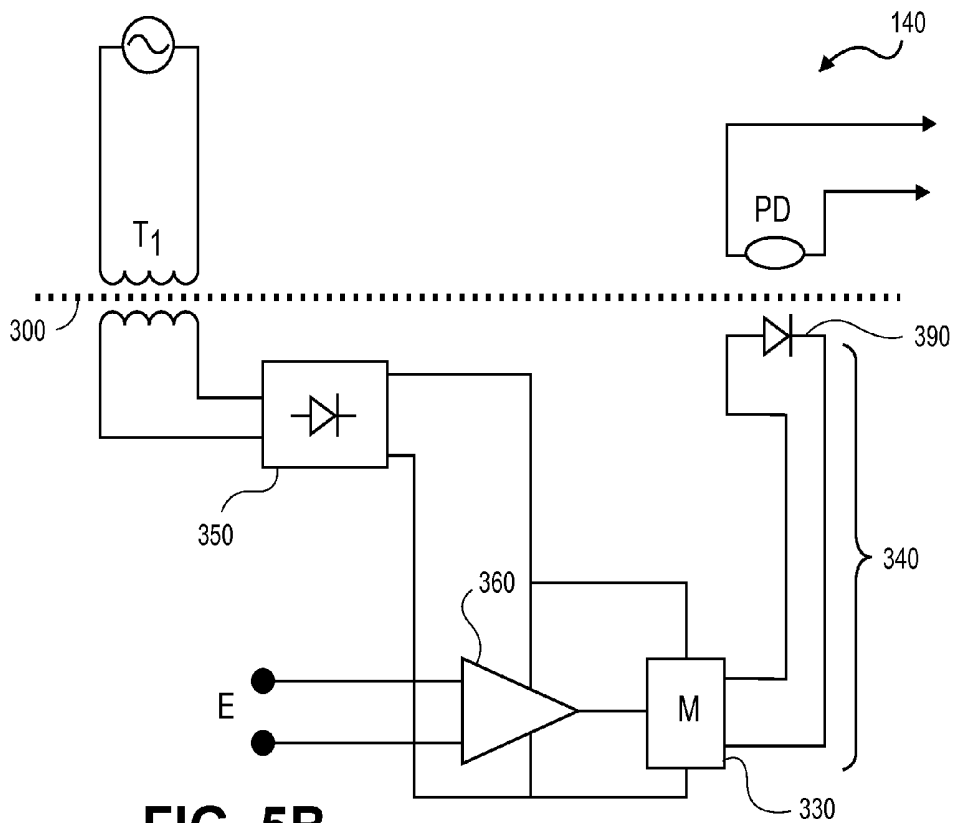
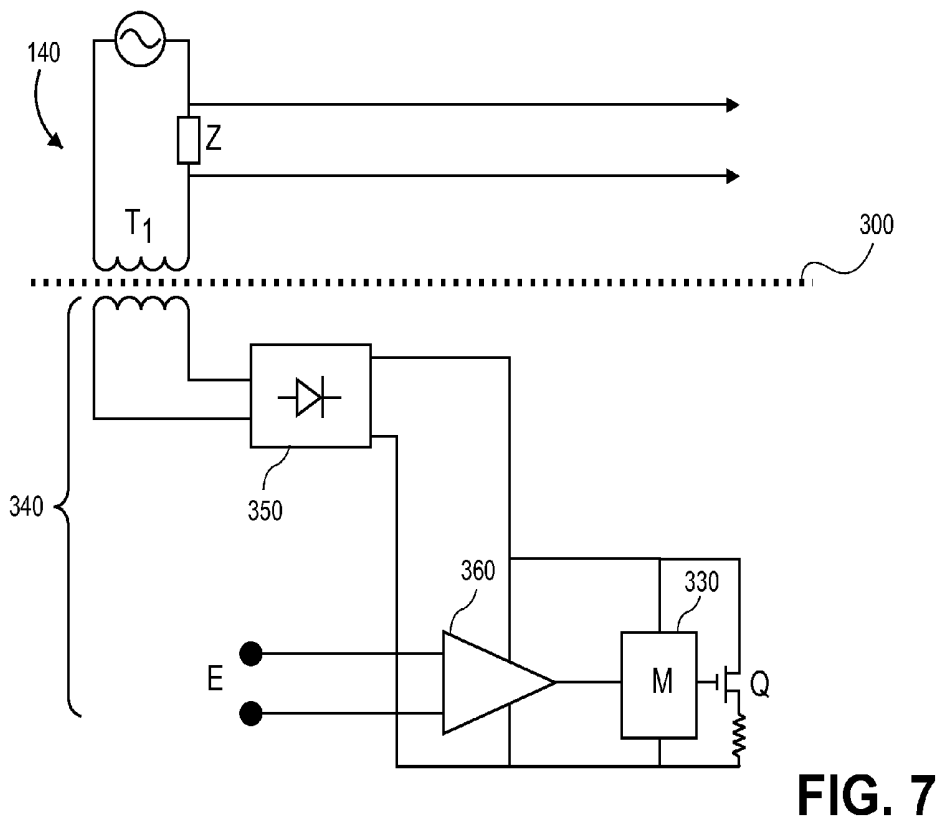
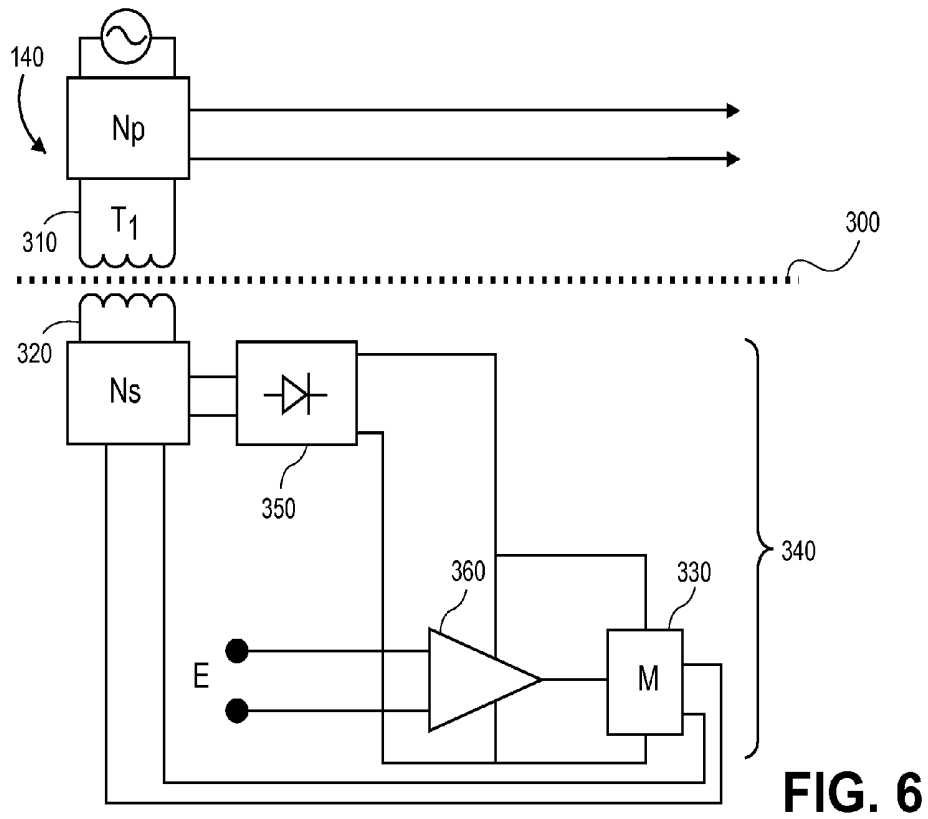

FIG. 5B



MEGNETIC ELECTRICAL CONNECTOR FOR PATIENT MONITORS

PRIORITY CLAIM

[0001] This application claims the benefit of priority under 35 U.S.C. §119(e) of the following U.S. Provisional Patent Application No. 61/387,426, titled "Magnetic Electrical Connector For Patient Monitors," filed on Sep. 28, 2010, and incorporates that application by reference herein in its entirety.

REFERENCE TO RELATED APPLICATIONS

[0002] This application is related to U.S. Provisional Patent Application No. 61/387,457, titled "Depth of Consciousness Monitor Including Oximeter," filed on Sep. 28, 2010, and incorporates that application by reference herein in its entirety.

FIELD OF THE DISCLOSURE

[0003] The present disclosure relates to the field of patient monitoring devices. More specifically, the disclosure relates to electrical connectors for patient monitors adapted to measure blood analyses through optical noninvasive sensors.

BACKGROUND OF THE DISCLOSURE

[0004] Electric potentials evoked within a living subject are often sensed with electrodes or assemblies of multiple electrodes placed on the surface of a subject's or patient's body. In many clinical applications, the electric potentials acquired by the electrodes are processed, displayed, and/or recorded by instruments located remotely from the body. In such cases, the electrodes or electrode assemblies communicate with the remote instruments through connecting wires and cables of suitable length from the subject to the instrument.

[0005] While the foregoing electrodes are frequently designed to be disposable after use on a single subject, the cables and wires are generally intended to be reused multiple times. The electrodes often include terminals, connectors, or similar assemblies by which they can be detachably connected to the wires and/or cables. The contact surfaces at the points of connection may be subject to contamination, corrosion, or the like, they may cause unreliable connections, or degrade the quality of the bioelectric potentials, which are usually of very low voltage levels. The foregoing connections also may be subject to the ingress of fluids and any fluids entering a connector may degrade its performance. Additionally, many electrical connectors include traditional male and female mechanically matable components where at least one side often includes a cavity, recess, or the like. The cavity or recessed mechanical structures may trap biological contaminants making cleaning and sterilization difficult. Such difficulties may be exacerbated if the cable or wire is used on multiple subjects.

[0006] In addition to the foregoing, cables and wires leading from the patient to an instrument also present technical challenges regarding signal integrity. The capacitance between the wires of a given cable may present an undesirable electrical loading on the electrodes. Also, when flexed, cables may evoke triboelectric potentials, which may interfere with the signals of interest. Moreover, cables or wire may pick up electromagnetic interference, which may also degrade the signals of interest.

[0007] Often, for safety and signal integrity reasons, an instrument which acquires the electrode potentials generally has its inputs electrically isolated from ground, as well as from other circuits which may contact other parts of the subject. However, a long cable may create significant capacitance to ground, as well as to adjacent cables, at least in part defeating that isolation. The foregoing may lead to signal degradation, often in the form of reduced common-mode rejection. This drawback may be exacerbated where electro-surgical and related RF devices are employed in a subject.

[0008] Embodiments of the present disclosure seek to overcome some or all of these and other problems.

SUMMARY OF THE DISCLOSURE

[0009] Based on at least the foregoing, the present disclosure seeks to overcome some or all of the drawbacks discussed above and provide additional advantages over any prior technologies. For example, some or all of the foregoing drawbacks may advantageously be mitigated by signal isolation very near the electrodes, such that the electrodes are buffered and/or isolated from the effects of the cable and wiring. In general, designers of electrical components will recognize from the disclosure herein several modalities that accomplish electric signal isolation, including for example, magnetic, optical, or radiofrequency links, and capacitive coupling. An example of magnetic isolation is a transformer having primary and secondary windings separated by an insulating barrier. An optocoupler is an example of an optical isolation device, in which light from an intensity-modulated source passes through an insulating barrier and impinges on a photodetector, which recovers the original modulating signal. A modulated radio transmitter and demodulating receiver are still another example of a signal isolation device.

[0010] In an embodiment where the physical separation is large compared to a wavelength of the radio frequency, electromagnetic wave propagation is an operative coupling mechanism. In an embodiment where the transmitter and receiver are located in very close proximity, near-field coupling may be operative. In an embodiment, near-field coupling may be established magnetically by coils having mutual inductance yet insulated from each other, or may be established electrostatically by a small capacitance present across an insulating barrier between the transmitter and receiver circuits. A designer will recognize from the disclosure herein still and other methods. In an embodiment, the near field coupling mechanisms may also be used in conjunction with designs which are not strictly radiofrequency carriers. For example, the ISO721 and related devices, manufactured by Texas Instruments of Dallas, Tex., transmit digital signals across an insulating barrier by means of sensing pulse edges coupled through the tiny capacitance existing across the barrier.

[0011] In an embodiment, a device designer can use signal isolation to potentially establish a point of physical disconnection at the location of the insulating barrier. This may allow the designer to create an electrical connector with fewer or no exposed conductive parts. For example, in an embodiment, a transformer may have appropriate electrical characteristics to couple with the signal provided by a pair of electrodes on a subject's body. In an embodiment, the primary winding of this transformer may advantageously be a disposable electrode assembly placed near or on a patient. The cable leading to the instrument could be equipped with a secondary coil. Connection of the cable to the electrode assembly would

be accomplished by bringing the coils into physical proximity, such that they are magnetically coupled, forming a transformer. It is noteworthy that this connection may have fewer or no exposed conductive parts, may be made immune or resistant to the ingress of liquids, and may be designed to be free from small cavities that would entrap biological materials, each reducing the risk of contamination and improving the efficiency and effectiveness of sterilization and signal coupling.

[0012] In an embodiment, a device designer can use a system for isolation of electrical components of a physiological monitoring system that comprises a sensor for detecting an indication of a physiological parameter, a patient monitoring system for displaying information transmitted from the sensor, an instrument cable connecting the sensor and the patient monitoring system, a sensor cable connecting the sensory components of the sensor to the instrument cable and a signal isolation coupling located along the sensor cable. This system could utilize an EEG sensor, a pulse oximeter, or a combination cerebral oximeter and EEG forehead sensor. The EEG forehead sensor may include a disposable portion that contains an EEG electrode cable connecting a set of EEG electrodes to the sensor cable. The EEG electrode cable may include a signal isolation coupling which may include an insulating barrier, or inductive components, for example, transformers. In some embodiments, the cerebral oximeter may be reusable.

[0013] A device designer may use a forehead sensor for isolation of electrical components of the sensor that includes at least one sensory component for detecting an indication of a physiological parameter of a patient, a sensor cable connected to the at least one sensory component for providing power and communication to the at least one sensory component, and a signal isolation coupling along the sensor cable. The at least one sensory component may be a plurality of EEG electrodes, a cerebral oximeter or pulse oximeter.

[0014] In an embodiment, a device designer can use a combination cerebral oximeter and EEG forehead sensor for isolation of electrical components that includes a reusable portion containing cerebral oximetry sensory components capable of detecting the cerebral oxygenation of matter inside the cerebral cavity, a disposable portion containing EEG electrodes capable of detecting electrical activity on a patient's skin, a disposable cable connecting the EEG electrodes to the reusable portion, and a signal isolation coupling connecting the disposable cable to the reusable portion. The sensor's signal isolation coupling may completely surround the signal isolation coupling to allow easy cleaning of the signal isolation coupling.

[0015] For purposes of summarizing the disclosure, certain aspects, advantages and novel features of the disclosure have been described herein. Of course, it is to be understood that not necessarily all such aspects, advantages or features will be embodied in any particular embodiment of the disclosure.

BRIEF DESCRIPTION OF THE DRAWINGS

[0016] The drawings are provided to illustrate embodiments of the disclosures described herein and do not limit the scope thereof.

[0017] FIG. 1A-1E illustrate various patient monitoring devices communicating with optical sensors over cabling and through connections where signal isolation is preferred, according to embodiments of the present disclosure.

[0018] FIG. 2A illustrates a simplified block diagram of an embodiment of a pulse oximetry unit, according to the present disclosure.

[0019] FIGS. 2B-2C illustrate simplified block diagrams of embodiments of a brain oximetry unit, according to the present disclosure.

[0020] FIGS. 3A-3E illustrate various embodiments of signal isolation coupling, according to the present disclosure. For example, FIGS. 3A-3B illustrate a cross-sectional view of an embodiment of the signal isolation coupling including a transformer and separation barriers, according to the present disclosure. FIGS. 3C-3E illustrate various circuit diagrams of an embodiment of the signal isolation coupling including a transformer, according to the present disclosure.

[0021] FIGS. 4A-4B illustrate circuit diagrams of a signal isolation connection including a modulator according to an embodiment of the present disclosure.

[0022] FIGS. 5A-5D illustrate circuit diagrams of a signal isolation connection including amplification of the bio-potential signals according to an embodiment of the present disclosure.

[0023] FIGS. 6-7 illustrate circuit diagrams of a signal isolation connection employing alternate power sources according to an embodiment of the present disclosure.

DETAILED DESCRIPTION OF THE PREFERRED EMBODIMENT

[0024] The present disclosure is generally related to signal couplings. In an embodiment, in order to provide an electrical coupling with fewer exposed conductors, and which reduces the ingress of liquids and entrapment of biological materials, an isolation connection is provided utilizing inductance and a physical gap between the conductors of the coupling. In an embodiment, a variety of medical devices could utilize a signal isolation connection between, among other places a sensor or other component interacting with a patient's body and the main instrument. For example, a device designer could implement a signal isolation component between a pulse oximeter and pulse oximetry sensor, an electroencephalogram "EEG" and the EEG electrodes, an electrocardiograph "ECG" and the ECG electrodes, acoustic throat sensors and a respiratory monitor, a temperature probe and a thermometer, and other medical devices with elements that come into close contact with a patient's body.

[0025] FIGS. 1A-1E illustrate various embodiments of medical devices that may incorporate a signal isolation coupling as disclosed herein. FIG. 1A illustrates an embodiment of a combination cerebral oximeter and EEG forehead sensor **120** connected by an instrument cable **150** to a conventional pulse oximeter **130**. In this embodiment, a signal isolation coupling **140** could be implemented along the instrument cable **150**, between the connection of the forehead sensor to the instrument cable **160** and the patient electrodes and sensors **170**, or the like.

[0026] In an embodiment, the combination EEG and cerebral oximetry forehead sensor **120** may utilize both disposable and reusable components. For example, the disposable portion may advantageously include components near a measurement site surface (the patient's skin), including, for example, an EEG, a temperature sensor, tape, adhesive elements, positioning elements, or the like. The reusable portion may advantageously include more expensive or other components, circuitry and/or electronics. Although the reusable portion may still include time-of-use restrictions for quality

control, it may be used multiple times for a single patient, across different patients, or the like. The reusable components may include, for example, cerebral oximetry components, pulse oximetry components and other components to measure other various parameters.

[0027] In an embodiment, the connection that connects the disposable portion and the reusable portion of the sensor 120 may be a signal isolation coupling 140 as disclosed herein. The signal isolation coupling 140 could be implemented at any point along either or both of a cable 150 connected to the disposable portion of the sensor 120 and/or a cable 150 connected to a reusable portion of the sensor 120. In one embodiment, the disposable portion of the sensor 120 has a cable 150 connected to it, which in turn has an isolation coupling 140 that connects or communicates with a second cable 150 connected to the reusable portion of the sensor 120. The connection on the cable 150 connected to the reusable portion of the sensor 120 could be at any location along the cable 150 including the connection with the reusable portion of the sensor 120 or the connection to a main cable 150 that interfaces with a medical instrument, such as, for example, an oximeter, a respiration monitor, a blood pressure monitor, or the like.

[0028] In an embodiment, a portion of the sensor 120 may communicate with or transmit power with another portion of the sensor 120 or any wire or other electrical connection leading to the signal processing and conditioning unit 190 through a signal isolation coupling 140 as disclosed herein. In an embodiment, the signal isolation coupling 140 could include an inductance connection with transformers embedded near the surface of each half of the connector that are housed by an insulator, for example, plastic. In an embodiment, the two halves of the connector could then be brought in close contact and be removably connected in place to provide a data communication, power connection, or the like.

[0029] FIGS. 1B-1E illustrate various additional embodiments of monitoring devices utilizing a finger clip sensor 200 and an instrument, such as, for example, a pulse oximeter 130. In an embodiment, a signal isolation coupling 140 may be implemented in these embodiments in various places along an instrument cable 150 connecting the sensor 120 to the instrument, or in other positions.

[0030] FIG. 2A illustrates a block diagram of a pulse oximeter system 210. In an embodiment, a signal isolation coupling 140 may be integrated into the system between, for example, the detectors 235 and the front-end interface 220, the emitter 230 and the front end interface 220 and the signal processor 240, the signal processor 240 and the network interface 250, or any other part of the system that may benefit from a signal isolation coupling 140. FIG. 2B illustrates an embodiment of a block diagram of a patient monitoring system 260 that includes a pulse oximeter 130, a brain oximetry unit (signal processing and conditioning) 190 for processing and conditioning signals from various sensors, and a variety of sensors 120 for detecting various physiological parameters of a patient. Illustrated are S_pO_2 , EEG, temperature, and brain oximetry sensors 120.

[0031] In an embodiment, the sensors 120 may have a front end 220 associated with the sensor 120 included with the brain oximetry unit 190 for controlling the data and power flow between the processor 240 of the brain oximetry unit 190 and the various sensors 120. The front ends 220 communicate

drive signals to the various sensors 120 and transmit and/or condition data or signals received from and detected by the sensors 120.

[0032] In an embodiment, a signal isolation coupling 140 may be implemented in various places on the patient monitoring system 260. For example, the signal isolation coupling 140 may be implemented between any of the sensors 120 and its corresponding front end 220, any of the front ends 220 and the processor 240 on the brain oximetry unit 190, between the brain oximetry unit 190 and the conventional pulse oximeter 130, or any other suitable location.

[0033] FIG. 2C illustrates an embodiment similar to FIG. 2B including wireless communication with various sensors 120 and between a brain oximetry unit 190 and a monitoring station 260, such as a multiple patient monitoring system or multiple parameter monitoring system.

[0034] FIGS. 3-7 illustrate embodiments of signal isolation coupling 140 that may optionally be implemented for various couplings in a medical instrument. In an embodiment, the signal isolation coupling 140 may be achieved through various means including magnetic, optical, radiofrequency links and capacitive coupling. In an embodiment, the magnetic isolation could be a transformer. In another embodiment, an optical coupler could be used for an optical isolation device, in which light from an intensity modulated source passes through an insulating barrier and impinges on a photodetector or other light detector, which recovers the original modulating signal.

[0035] In another embodiment, a modulated radio transmitter and demodulation receiver may be implemented to provide a signal isolation coupling 140. In an embodiment where the physical separation is large compared to the wavelength of the radio frequency, electromagnetic wave propagation may be used to provide a coupling connection. In another embodiment, when the transmitter and receiver are located in close proximity, near-field coupling may be used to provide a connection. In an embodiment, near-field coupling may be established magnetically by coils having mutual inductance but insulated from each other, or electrostatically by a small capacitance present across an insulating barrier between the transmitter and receiver circuits. The near field coupling mechanisms may also be used in conjunction with schemes which are not strictly radiofrequency carriers. For example, the ISO721 and related devices, manufactured by Texas Instruments (Dallas, Tex., USA), transmit digital signals across an insulating barrier by means of sensing pulse edges coupled through the tiny capacitance existing across the barrier.

[0036] FIG. 3A illustrates an embodiment of a signal isolation coupling 140 connecting the reusable portion 270 and the disposable portion 280 of the combination EEG and cerebral oximetry forehead sensor 120 disclosed herein. The reusable portion 270 and disposable portion 280 of the sensor 210 each have a portion including signal isolation coupling 140 components 290, including transformers to provide an inductance connection. FIG. 3A-3B illustrate an embodiment of the signal isolation coupling 140 with a physical separation between the conductive components.

[0037] In an embodiment, an insulating barrier 300 separates the inductive electrical components 290 and provides physical separation between them. In an embodiment, the signal isolation components 290, for example, the transformers, are able to establish an electrical connection across the insulating barrier 300 and physical separation through induc-

tance of the coils. In an embodiment, the insulating barrier 300 provides a connection with fewer or no exposed conductive parts, and insulation of the conductive components by an appropriate electrical insulating material known in the art. In an embodiment, the insulation of the conductive components and reduced exposure of conductive parts allows the connection to be resistant to the ingress of liquids, and may be designed to be free from small cavities that would entrap biological materials.

[0038] In an embodiment, the primary winding 310 of the transformer of the signal isolation coupling 140 could be incorporated in the disposable portion 280 of the sensor 120 or other part of a sensor 120 near the patient interface. As illustrated in FIG. 3A the secondary coil 320 could be included in the reusable portion 270 of the sensor 120 or the instrument cable 150 leading to another medical instrument. In this embodiment, the electrical coupling between the patient interface side and instrument side of the signal isolation coupling 140 could be accomplished by bringing the coils into physical proximity, such that they would be magnetically coupled, forming a complete transformer.

[0039] In another embodiment, the connection between the reusable portion 270 of the sensor and the cable 150 leading to the instruments, for example the brain oximetry unit 190, conventional pulse oximeter 130 and/or other patient monitoring station 260 may be an optical isolation component.

[0040] FIG. 3B illustrates an embodiment of the signal isolation connection 140 with several signal isolation components 290. In one embodiment, the several signal isolation components 290 may be a multitude of transformers placed appropriately to allow the conductors of the primary 310 and secondary coils 320 to be in close proximity with an insulating barrier 300 physically separating the components and preventing direct physical contact between the conductive components of the signal isolation coupling 140.

[0041] Although the physical connection is isolated, the two components may be removably held in proximity to one another through a wide variety of attachment mechanisms, including magnetic, straps with catches, Velcro, matable mechanical components, press fit components, adhesives, fasteners of all types, wraps, bandages, or the like. In an embodiment, the proximity mechanism advantageously provides a sterilizable environment having a reduced number of cavities or the like that may trap contaminants. In an embodiment, the proximity mechanism is entirely disposable.

[0042] A signal isolation coupling 140 utilizing transformers may take on several embodiments, exemplary embodiments of which are illustrated in FIGS. 3C-3D. For example, the signal isolation coupling 140 may include of a pair of planar coils, where establishing connection of the electrode assembly to the cable includes bringing the coils into proximity face-to-face. An embodiment of this construction is shown in FIG. 3C where the primary coils 310 and secondary planar coils 320 have terminals labeled P and S respectively. The dotted line represents the insulating barrier 300 between the coils, and is also the division along which coils may be separated when the signal isolation coupling 140 is decoupled.

[0043] FIG. 3D illustrates an embodiment of a cross-section of a transformer with a pair of co-axial solenoid coils. The heavy dotted line represents the insulating barrier 300 between the coils, and is also the division along which the coils may be separated when the signal isolation coupling 140 is decoupled. In an embodiment, an electrical connection may

be established by inserting one coil within the other, and disconnected by drawing the coils apart. In either of these embodiments, a magnetic core may be added to enhance the coupling already present between the coils. FIG. 3E illustrates an embodiment in which the primary coils 310 and secondary coils 320 are not oriented so as to be coupled directly. In this embodiment, a separable magnetic core may be provided to couple the coils when the two parts are brought in proximity of each other.

[0044] Bio-potential signals often have low frequencies, often less than about 1 Hz, and tend to be sourced from fairly high impedances. In an embodiment, coupling a signal of this nature may require a transformer having relatively large inductance. A further challenge is that bio-potential signals tend to have relatively small amplitudes, in the millivolt or microvolt range. A transformer configured to pass signals with such characteristics may tend to act as a pickup coil for stray magnetic fields in the vicinity of the subject, such as mains-frequency magnetic fields. In an embodiment, however, various devices may convert the bio-potential signal into a form more suitable for passing through a practical separable transformer or other separable isolation device before passing the signals through the signal isolation coupling 140. In an embodiment, this may be accomplished by adding various electronic circuits to the electrode assembly.

[0045] One such embodiment of an electrical system designed to condition a bio-potential signal for passing through a signal isolation coupling 140 utilizing transformers includes a modulator circuit to convert the low-frequency bio-potential signal into a high frequency signal, better suited to be passed through a small and practical separable transformer. In one form of this embodiment, a pair of separable transformers is used, as seen in FIG. 4A. In this embodiment, the electrode assembly 340 including the electrodes E has been equipped with a modulator 330 and one winding each of the transformers T1 and T2. In an embodiment, the transformer T1 passes a carrier frequency excitation from the instrument cable 150 to the electrode assembly. The modulator 330 may then modulate this carrier frequency with the bio-potential signal applied at the electrodes E. The modulated signal is then passed back to the instrument cable through the transformer T2. Both transformers may be of any of the separable forms described herein or other suitable transformers known in the art from the disclosure herein, such that the electrode assembly 340 may be detached from the instrument cable 150 along the dotted line. In embodiments where multiple bio-potential signal channels are involved, a single excitation transformer may be used to serve all channels. The modulator 330 may include of a simple circuit, having no power supply, other than the carrier signal itself. Examples of these suitable modulators 330 would be modulators using diode or transistor switches in any of the many circuit configurations well known in the art from the disclosure herein of constructing modulator and mixer circuits. FIG. 4B illustrates one exemplary modulator 330 circuit topology employing MOSFET switches. This circuit provides simplicity and economy of cost and is readily adaptable to a disposable electrode assembly. However, other embodiments of modulator 330 are possible, and with the application of integrated circuit technology, may be made suitably compact and inexpensive for practical use.

[0046] Another embodiment utilizes a single separable transformer to address the difficulties of bio-potential signals. In this embodiment, the electrode assembly 340 includes a

parametric modulator circuit connected to the secondary coil of the separable transformer. In an embodiment, the parametric modulator may include diodes, varactor diodes, or other non-linear devices which change impedance as a function of the bio-potential signals. The bio-potential signal may be observed by measuring the impedance reflected through the separable transformer when an excitation is applied to the transformer's primary coil. In another embodiment, the parametric modulator may generate a harmonic or sub-harmonic of the excitation signal, the amplitude of this harmonic or sub-harmonic being modulated by the bio-potential signal, and being observable at the primary side of the separable transformer.

[0047] In an embodiment, as discussed herein, the bio-potential signals may be a relatively small amplitude, and it thus may be advantageous to amplify these signals before passing them into the modulator 330 or other similar circuit. Illustrated in FIG. 5A is an embodiment of an amplification circuit designed to be applied to a modulation circuit or directly to a transformer circuit. Shown is the transformer T1 equipped with a rectifier 350, which provides a DC supply voltage to the sensor 120 or other instrumentation device. This voltage supplies an amplifier 360, which amplifies the bio-potential signal acquired by the electrodes E. In an embodiment, the amplified signal is then applied to the modulator 330, which returns a modulated signal to the instrument cable 150 by means of the transformer T2.

[0048] However, as a power supply voltage is now available to the modulator 330, it may have an expanded scope of operation as compared to the embodiment illustrated in FIGS. 4A-4B. For example, it may modulate the carrier frequency supplied through T1, as before. However, it may develop its own, different carrier frequency, and may use any manner of various modulation schemes, such as amplitude, phase, or frequency modulation. In an embodiment, it may include an analog to digital converter, digital signal processing, and other functions and circuits, such that its output is a digital representation of the original bio-potential signal. This digital representation may be coupled directly through the transformer T2 or may be modulated, by any of the various means known in the art, on a carrier signal before being passed through the transformer T2.

[0049] In other embodiments of the signal isolation coupling 140, the transformer T2 may be replaced with other types of devices. For example, the receiving coil of the transformer T2 may be replaced with some other suitable magnetic sensor, such as a GMR device. In another embodiment, the receiving coil of the transformer T2 may be replaced with some coupling device(s) not operating on a magnetic principle. For example, FIG. 5B illustrates the use of an optical coupling scheme, where the modulator 330 drives an LED or other optical light source 390, the radiation from which impinges on the photodetector PD which is integrated into the instrument cable 150. The dotted line indicates the insulating barrier 300 and the physical separation of the signal isolation coupling 140. In an embodiment, the material of the insulating barrier 300 may be substantially transmissive of the radiation of the light source 390.

[0050] In the case of an optical link, the modulator 330 may not be necessary, since the optical link can be designed to have adequate low frequency response, such that the base-band bio-potential signal can be directly passed. In another embodiment, as illustrated in FIG. 5C, an electrostatic coupling is created using the capacitance between small coupling

conductors 370 placed on opposite sides of the insulating barrier 300. In another embodiment, the modulator 330 includes an antenna 380 to transmit its output and/or receive input instructions, as seen in FIG. 5D. The radiated signal may be received either by an antenna A1 located in close proximity in the instrument cable connector 140, or by an antenna A2 located remotely, such as within a remote patient monitoring station 260. In this latter case, in an embodiment, the instrument cable 150 may be used to supply power to the electronics within the electrode assembly 340, while the return of the bio-potential is transmitted wirelessly.

[0051] In the embodiment shown in FIGS. 5A-5D it is possible to operate the system without the transformer T1 and the rectifier 350. In an embodiment, the disposable portion 280 of the sensor 120 may operate only for a short period of time, such as for the duration of a particular medical procedure. In another embodiment, where long term monitoring of the bio-potential signal may be desired, the electrodes may have a finite lifetime, for example, due to drying out and similar chemical effects. Therefore, the power supplied by the transformer T1 and the rectifier 350 may instead be obtained from a small battery imbedded, for example, in the disposable portion 280 of the sensor 120. By the use of suitable low power electronic design techniques, balanced with appropriate selection of the battery type, sufficient battery life for many limited-time applications of the disposable portion 280 of the sensor 120 can be obtained. The coupling modalities illustrated in the various parts of FIGS. 5A-5D may also be adapted to battery operation. However, some have lower power requirements than others, and therefore may be better suited to particular intended service durations.

[0052] In the embodiments illustrated in the various parts of FIGS. 5A-5D, with either transformer or battery power, multiple channels of bio-potential signals obtained from additional electrodes may be multiplexed through a single coupling device of any of the types illustrated.

[0053] As illustrated in FIG. 6, it is possible to avoid the use of a battery while using a single coupling device for the signal isolation coupling 140. In an embodiment, the transformer T1 may serve as the coupling device. In this embodiment, the primary coil 310 and secondary coil 320 of the transformer T1 may be equipped with 3-port networks Np and Ns respectively. These are duplexing networks, which allow the power and modulated data to pass independently in opposite directions through the transformer T1. For example, in an embodiment, where the modulator 330 uses a carrier frequency higher than the power frequency, the networks would take the form of filters having high pass and low pass ports. In that embodiment, the networks Ns would extract the power through the low-pass port and apply it the rectifier 350. The modulator 330 would feed its output back through the high-pass port. Also, the network Np would apply power through its low-pass port and extract the modulator 330 signal through the high-pass port. Note that the modulated signal may be either an analog or digital representation of the bio-potential signal. Further, note that multiple bio-potential channels, from additional electrodes, may be multiplexed in either analog or digital format through the single transformer.

[0054] FIG. 7 illustrates another embodiment of a signal isolation coupling 140 which duplexes both power and signal through a single transformer. Shown is the output of the modulator 330 being used to operate a load device. In an embodiment, the load device then presents a variable load to the DC power developed by the rectifier 350, in response to

the modulated output. In FIG. 7, this is represented as transistor Q. The modulator 330 output is therefore reflected on the power supply current passed through the transformer T1, and may be recovered by monitoring this current. For example, an impedance Z placed in the power excitation circuit will develop a voltage representative of the modulator signal. Note that this is possible to eliminate the modulator 330, and apply the amplified baseband bio-potential signal to Q. In this embodiment, the supply current becomes modulated with the baseband signal, and impedance Z recovers an AM modulated voltage representative of the original biopotential signal. In an alternate embodiment, the load device may be designed to be operated with an AC voltage.

[0055] Although the foregoing disclosure has been described in terms of certain preferred embodiments, other embodiments will be apparent to those of ordinary skill in the art from the disclosure herein. Additionally, other combinations, omissions, substitutions and modifications will be apparent to the skilled artisan in view of the disclosure herein. Accordingly, the present disclosure is not intended to be limited by the reaction of the preferred embodiments, but is to be defined by reference to the appended claims.

[0056] In an embodiment, a device designer can use a system for isolation of electrical components of a physiological monitoring system that comprises a sensor for detecting an indication of a physiological parameter, a patient monitoring system for displaying information transmitted from the sensor, an instrument cable connecting the sensor and the patient monitoring system, a sensor cable connecting the sensory components of the sensor to the instrument cable and a signal isolation coupling located along the sensor cable. This system could utilize an EEG sensor, a pulse oximeter, or a combination cerebral oximeter and EEG forehead sensor. The EEG forehead sensor may include a disposable portion that contains an EEG electrode cable connecting a set of EEG electrodes to the sensor cable. The EEG electrode cable may include a signal isolation coupling which may include an insulating barrier, or inductive components, for example, transformers. In some embodiments, the cerebral oximeter may be reusable.

[0057] A device designer may use a forehead sensor for isolation of electrical components of the sensor that includes at least one sensory component for detecting an indication of a physiological parameter of a patient, a sensor cable connected to the at least one sensory component for providing power and communication to the at least one sensory component, and a signal isolation coupling along the sensor cable. The at least one sensory component may be a plurality of EEG electrodes, a cerebral oximeter or pulse oximeter.

[0058] In an embodiment, a device designer can use a combination cerebral oximeter and EEG forehead sensor for isolation of electrical components that includes a reusable portion containing cerebral oximetry sensory components capable of detecting the cerebral oxygenation of matter inside the cerebral cavity, a disposable portion containing EEG electrodes capable of detecting electrical activity on a patient's skin, a disposable cable connecting the EEG electrodes to the reusable portion, and a signal isolation coupling connecting the disposable cable to the reusable portion. The sensor's signal isolation coupling may completely surround the signal isolation coupling to allow easy cleaning of the signal isolation coupling.

[0059] Additionally, all publications, patents, and patent applications mentioned in this specification are herein incor-

porated by reference to the same extent as if each individual publication, patent, or patent application was specifically and individually indicated to be incorporated by reference.

What is claimed is:

1. A system for isolation of electrical components of a physiological monitoring system comprising:
 - a sensor for detecting an indication of a physiological parameter;
 - a patient monitoring system for displaying information transmitted from the sensor;
 - an instrument cable connecting the sensor and the patient monitoring system;
 - a sensor cable connecting the sensory components of the sensor to the instrument cable; and
 - a signal isolation coupling located along the sensor cable.
2. The system for isolation of electrical components between components of a physiological monitoring system of claim 1 wherein the sensor is an EEG sensor.
3. The system for isolation of electrical components of a physiological monitoring system of claim 1 wherein the sensor is a pulse oximeter.
4. The system for isolation of electrical components of a physiological monitoring system of claim 1 wherein the sensor is a combination cerebral oximeter and EEG forehead sensor.
5. The system for isolation of electrical components of a physiological monitoring system of claim 4 wherein the EEG forehead sensor includes a disposable portion that contains an EEG electrode cable connecting a set of EEG electrodes to the sensor cable.
6. The system for isolation of electrical components of a physiological monitoring system of claim 5 wherein EEG electrode cable includes a signal isolation coupling.
7. The system for isolation of electrical components of a physiological monitoring system of claim 5 wherein the cerebral oximeter is reusable.
8. The system for isolation of electrical components of a physiological monitoring system of claim 1 wherein the signal isolation coupling contains an insulating barrier.
9. The system for isolation of electrical components of a physiological monitoring system of claim 1 wherein the signal isolation coupling contains inductive components.
10. The system for isolation of electrical components of a physiological monitoring system of claim 9 wherein the inductive components include transformers.
11. A forehead sensor for isolation of electrical components of the sensor comprising:
 - at least one sensory component for detecting an indication of a physiological parameter of a patient;
 - a sensor cable connected to the at least one sensory component for providing power and communication to the at least one sensory component; and
 - a signal isolation coupling along the sensor cable.
12. The forehead sensor for isolation of electrical components of the sensor of claim 11 wherein the at least one sensory component is a plurality of EEG electrodes.
13. The forehead sensor for isolation of electrical components of the sensor of claim 11 wherein the at least one sensory component is a cerebral oximeter or pulse oximeter.
14. The forehead sensor for isolation of electrical components of the sensor of claim 12 wherein the signal isolation coupling contains an insulating barrier.

15. The forehead sensor for isolation of electrical components of the sensor of claim **14** wherein the signal isolation coupling includes inductive components.

16. A combination cerebral oximeter and EEG forehead sensor for isolation of electrical components comprising:

a reusable portion containing cerebral oximeter sensor components capable of detecting the cerebral oxygenation of matter inside the cerebral cavity;

a disposable portion containing EEG electrodes capable of detecting electrical activity on a patient's skin;

a disposable cable connecting the EEG electrodes to the reusable portion; and

a signal isolation coupling connecting the disposable cable to the reusable portion.

17. The combination cerebral oximeter and EEG forehead sensor of claim **16** wherein the signal isolation coupling includes an insulating barrier.

18. The combination cerebral oximeter and EEG forehead sensor of claim **17** wherein the insulating barrier completely surrounds the signal isolation coupling to allow easy cleaning of the signal isolation coupling.

19. The combination cerebral oximeter and EEG forehead sensor of claim **17** wherein the signal isolation coupling includes inductive components.

20. The combination cerebral oximeter and EEG forehead sensor of claim **17** wherein the signal isolation coupling includes transformers.

* * * * *

专利名称(译)	用于患者监护仪的磁性电连接器		
公开(公告)号	US20120088984A1	公开(公告)日	2012-04-12
申请号	US13/246768	申请日	2011-09-27
[标]申请(专利权)人(译)	AL ALI AMMAR KINAST ERIC KARL		
申请(专利权)人(译)	AL-ALI AMMAR KINAST ERIC KARL		
当前申请(专利权)人(译)	摩根大通银行, NATIONAL ASSOCIATION		
[标]发明人	AL ALI AMMAR KINAST ERIC KARL		
发明人	AL-ALI, AMMAR KINAST, ERIC KARL		
IPC分类号	A61B5/04 A61B5/1455 A61B5/00		
CPC分类号	A61B5/0476 A61B5/14551 A61B2562/245 A61B5/6814 A61B2562/227 A61B5/14553		
优先权	61/387426 2010-09-28 US		
其他公开文献	US9775545		
外部链接	Espacenet USPTO		

摘要(译)

本公开涉及一种用于在生理监测系统的各种部件之间提供信号隔离的电连接器。在一个实施例中，电连接器放置在传感器和相关联的监控系统之间，并且包括物理屏障和电感组件。

