



US 20070078316A1

(19) **United States**

(12) **Patent Application Publication**
Hoarau et al.

(10) **Pub. No.: US 2007/0078316 A1**

(43) **Pub. Date: Apr. 5, 2007**

(54) **MEDICAL SENSOR AND TECHNIQUE FOR USING THE SAME**

Publication Classification

(76) Inventors: **Carine Hoarau**, Lafayette, CA (US); **Li Li**, Petaluma, CA (US)

(51) **Int. Cl.**
A61B 5/00 (2006.01)
(52) **U.S. Cl.** **600/323; 600/336; 600/344**

Correspondence Address:
FLETCHER YODER (TYCO INTERNATIONAL, LTD.)
P.O. BOX 692289
HOUSTON, TX 77269-2289 (US)

(57) **ABSTRACT**

A sensor may be adapted to provide output to indicate when the sensor experiences abnormal forces or pressure. The forces may be outside forces, or the forces may be generated by patient motion. A sensor system as provided may also be adapted to correct for such forces when calculating measurements related to a physiological characteristic.

(21) Appl. No.: **11/240,682**

(22) Filed: **Sep. 30, 2005**

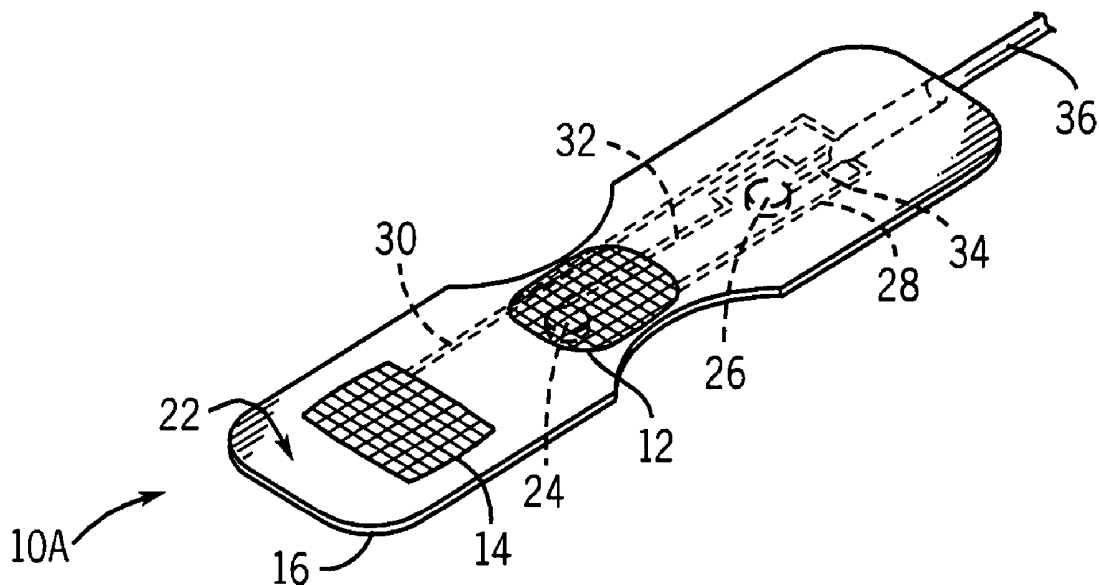

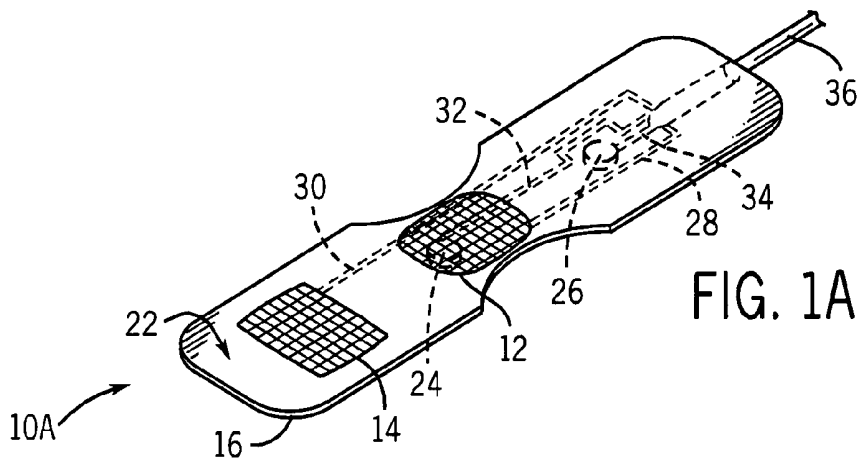

FIG. 1A

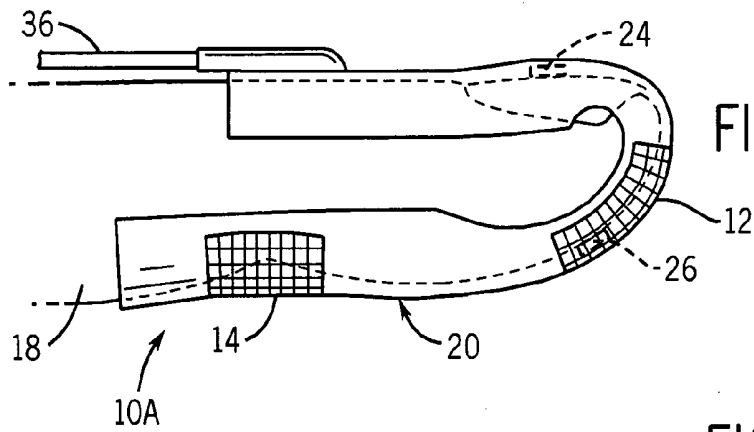

FIG. 1B

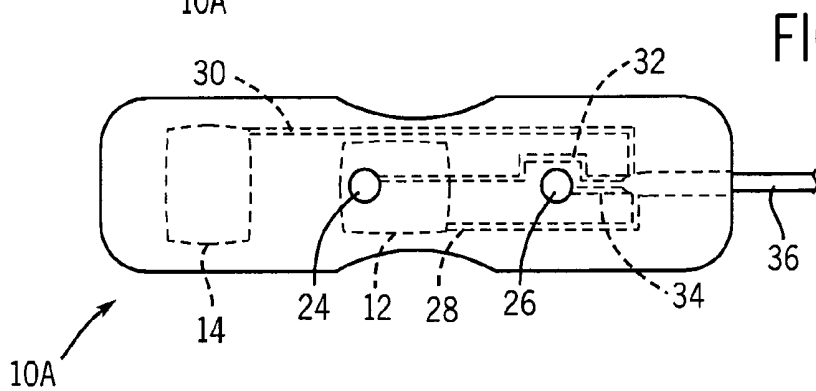

FIG. 1C

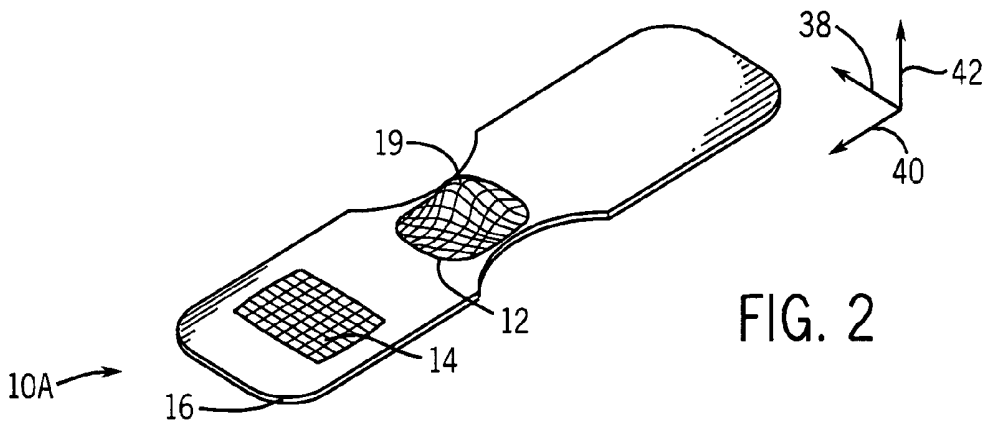
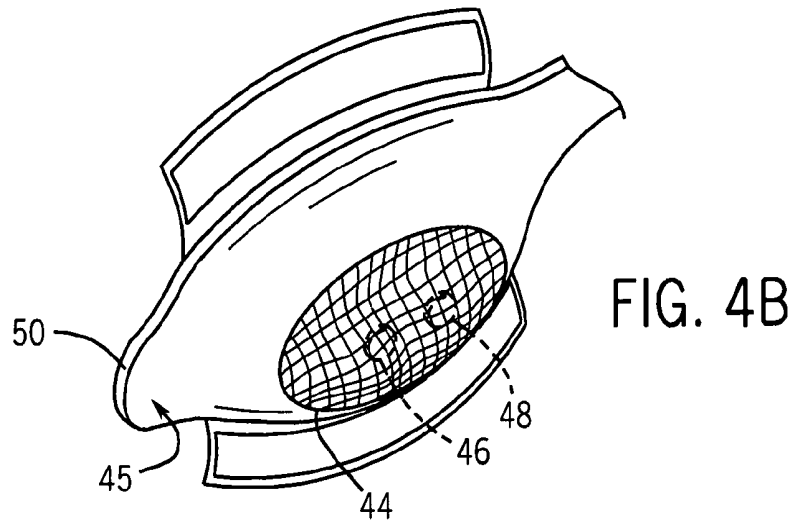
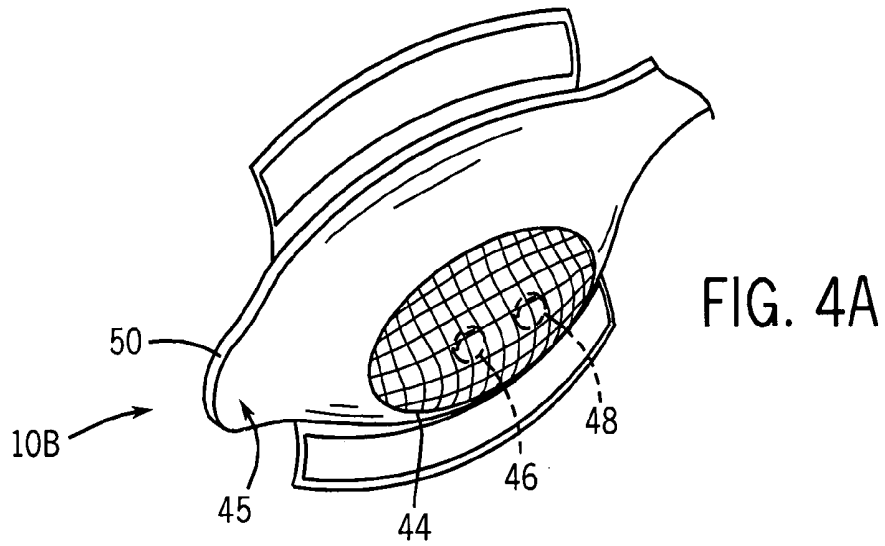
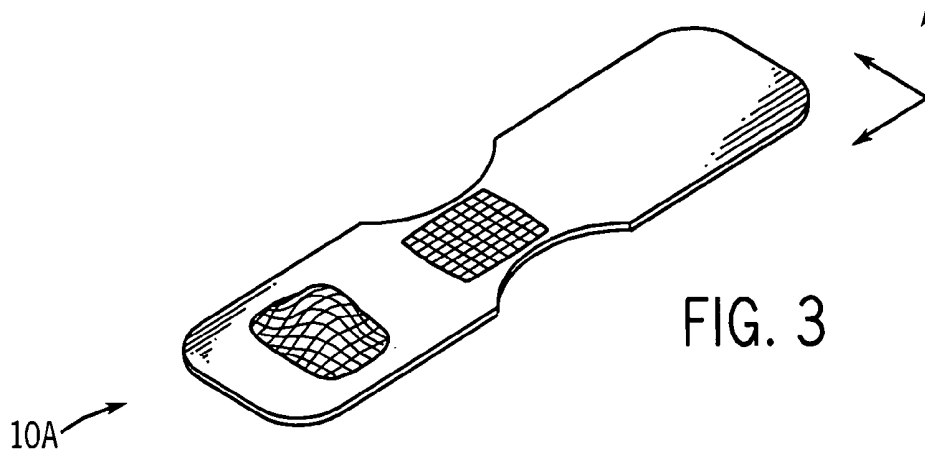

FIG. 2



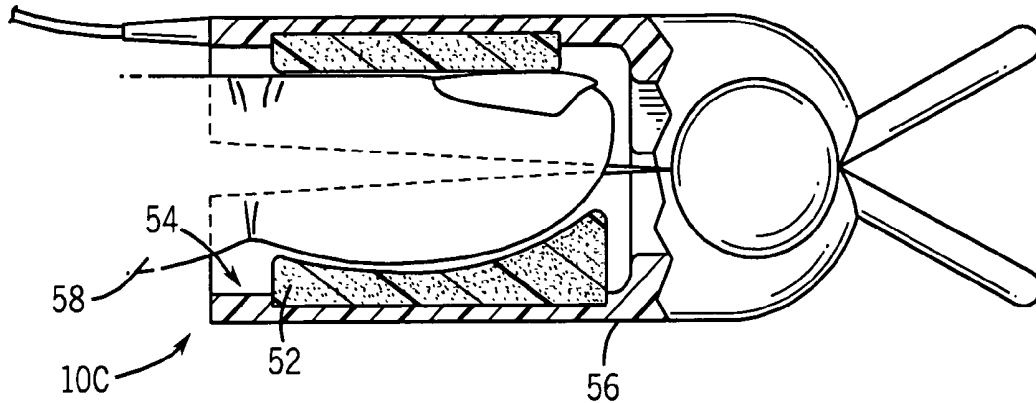

FIG. 5A

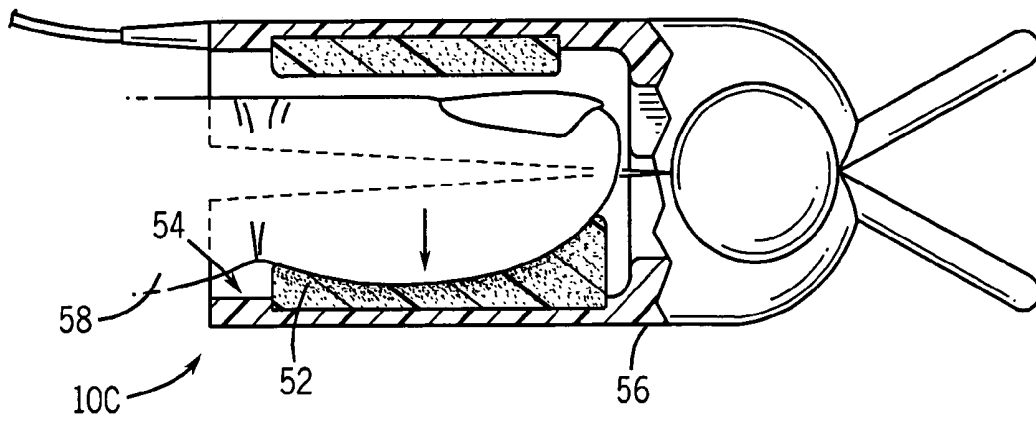

FIG. 5B

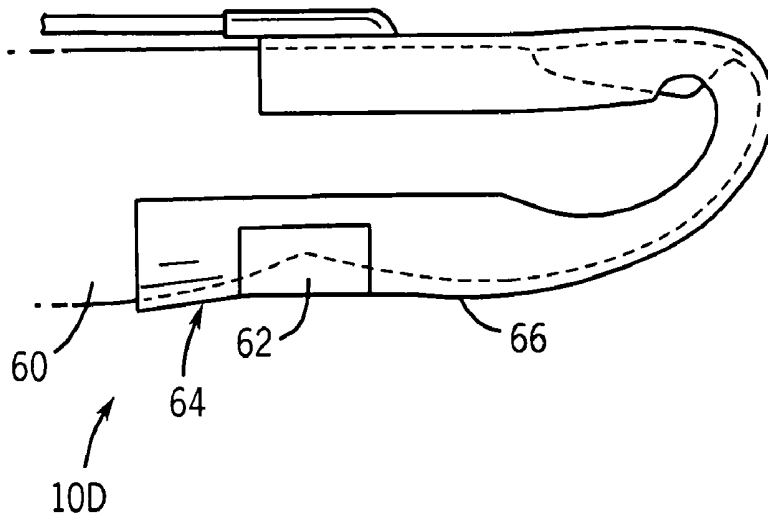

FIG. 6A

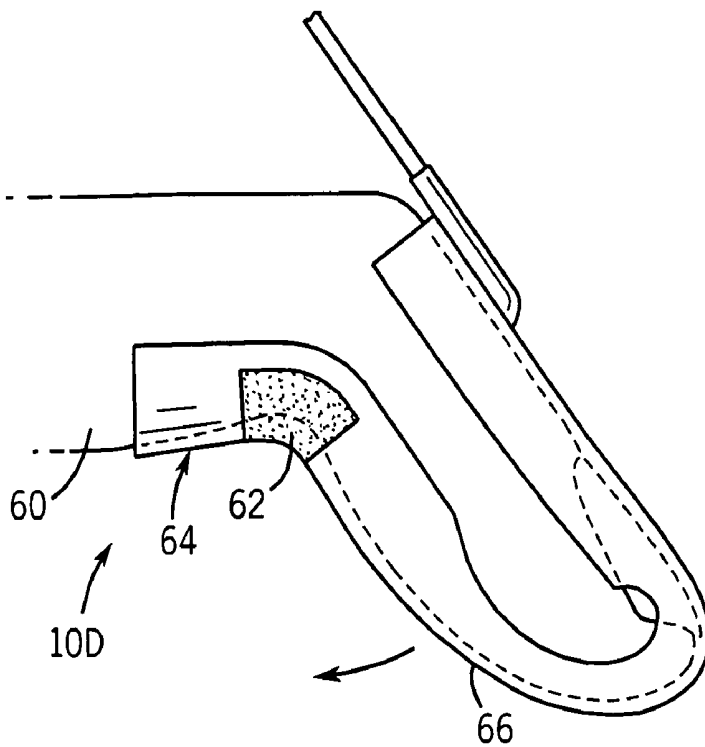

FIG. 6B

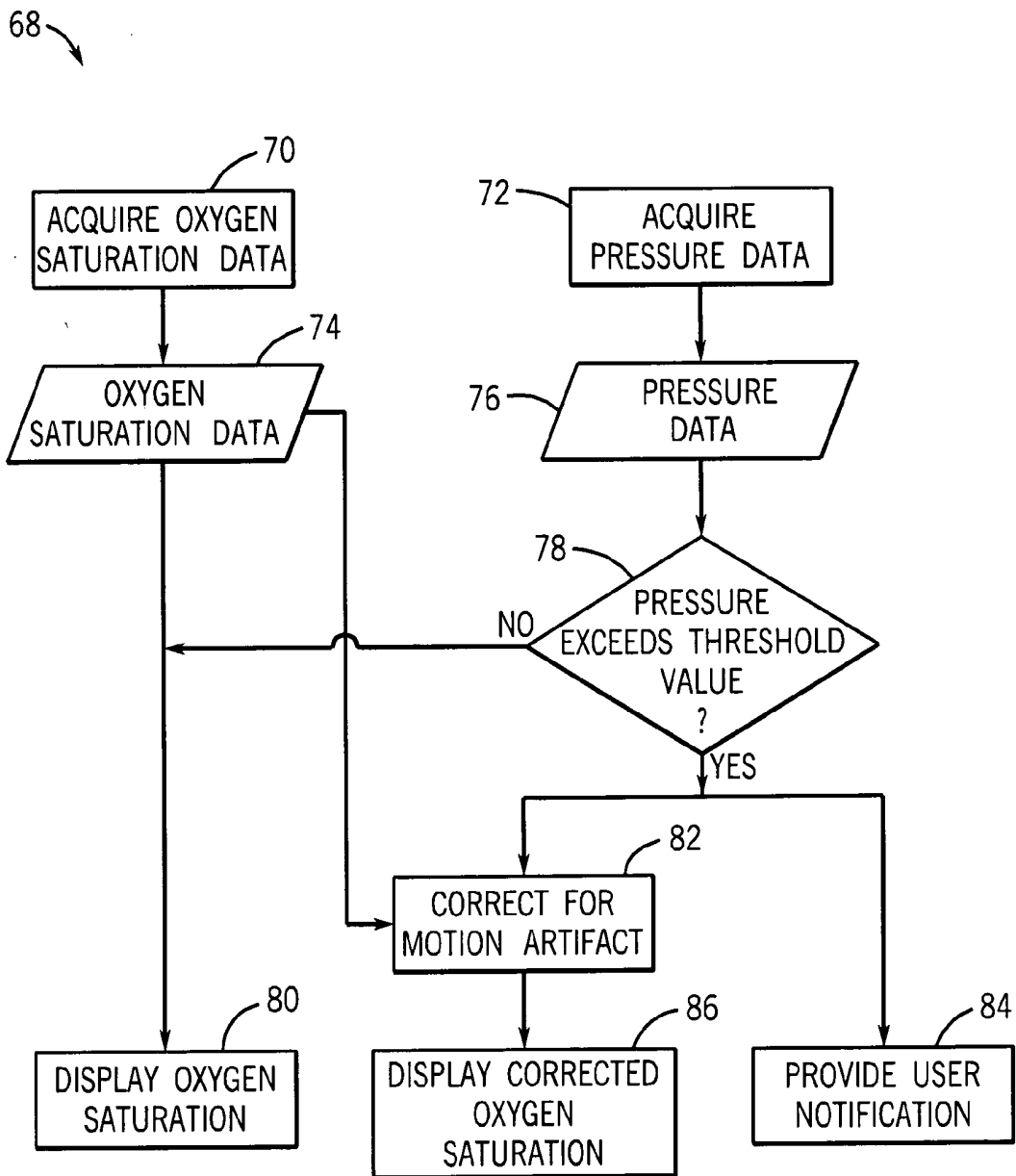

FIG. 7

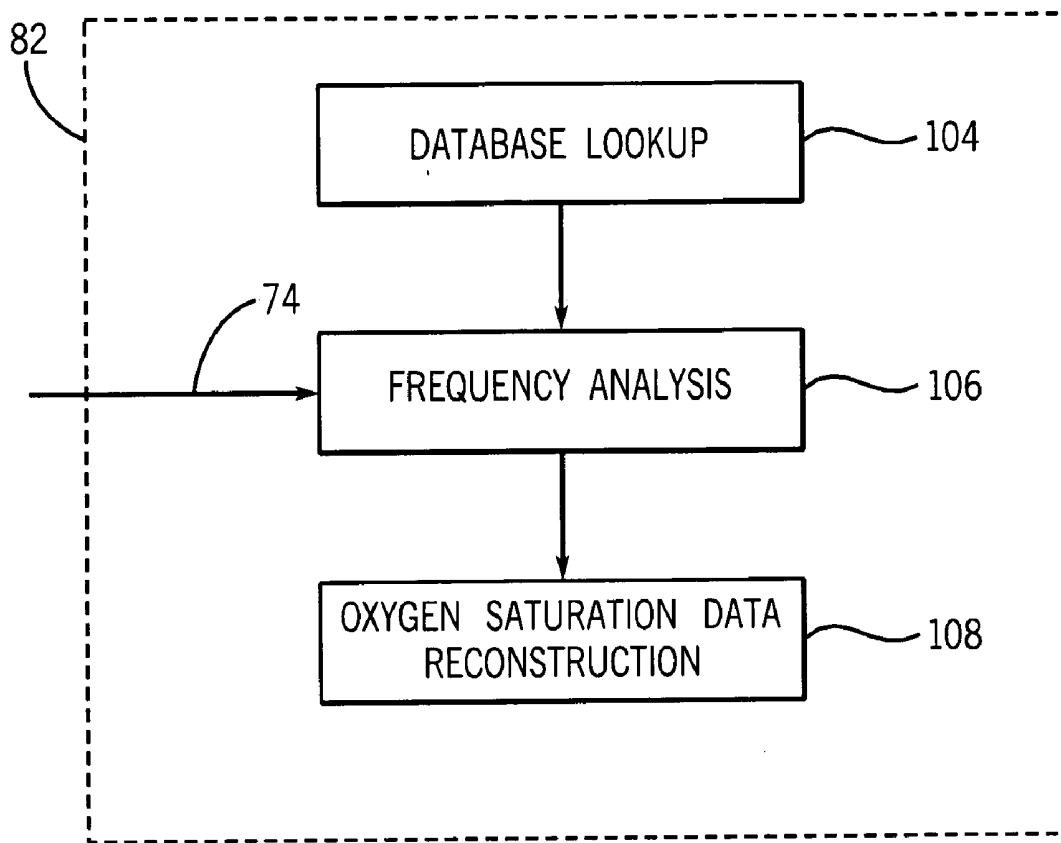

FIG. 8

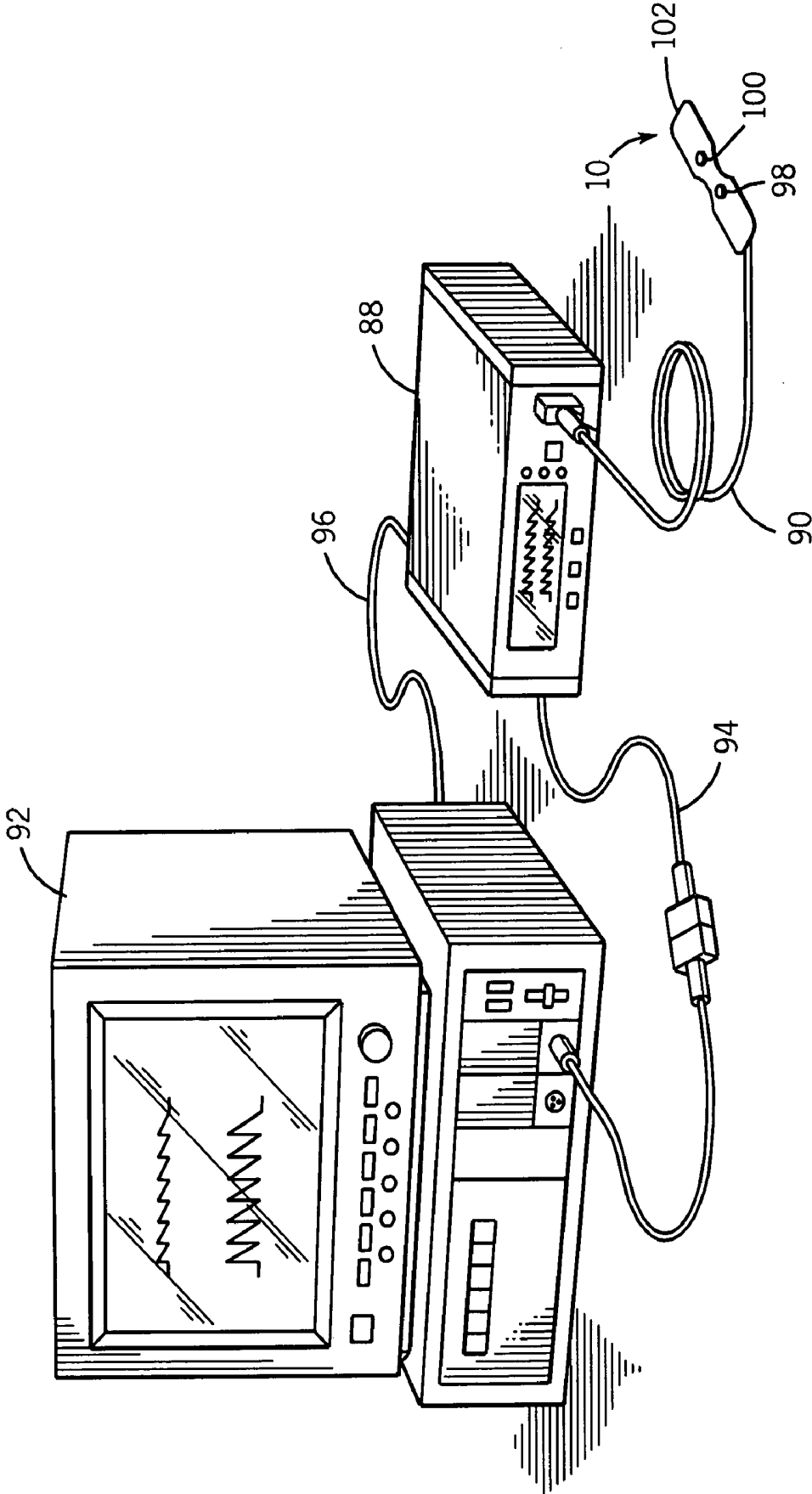

FIG. 9

MEDICAL SENSOR AND TECHNIQUE FOR USING THE SAME

BACKGROUND OF THE INVENTION

[0001] 1. Field of the Invention

[0002] The present invention relates generally to medical devices and, more particularly, to sensors used for sensing physiological parameters of a patient.

[0003] 2. Description of the Related Art

[0004] This section is intended to introduce the reader to various aspects of art that may be related to various aspects of the present invention, which are described and/or claimed below. This discussion is believed to be helpful in providing the reader with background information to facilitate a better understanding of the various aspects of the present invention. Accordingly, it should be understood that these statements are to be read in this light, and not as admissions of prior art.

[0005] In the field of medicine, doctors often desire to monitor certain physiological characteristics of their patients. Accordingly, a wide variety of devices have been developed for monitoring many such physiological characteristics. Such devices provide doctors and other healthcare personnel with the information they need to provide the best possible healthcare for their patients. As a result, such monitoring devices have become an indispensable part of modern medicine.

[0006] One technique for monitoring certain physiological characteristics of a patient is commonly referred to as pulse oximetry, and the devices built based upon pulse oximetry techniques are commonly referred to as pulse oximeters. Pulse oximetry may be used to measure various blood flow characteristics, such as the blood-oxygen saturation of hemoglobin in arterial blood, the volume of individual blood pulsations supplying the tissue, and/or the rate of blood pulsations corresponding to each heartbeat of a patient. In fact, the "pulse" in pulse oximetry refers to the time varying amount of arterial blood in the tissue during each cardiac cycle.

[0007] Pulse oximeters typically utilize a non-invasive sensor that transmits light through a patient's tissue and that photoelectrically detects the absorption and/or scattering of the transmitted light in such tissue. One or more of the above physiological characteristics may then be calculated based upon the amount of light absorbed or scattered. More specifically, the light passed through the tissue is typically selected to be of one or more wavelengths that may be absorbed or scattered by the blood in an amount correlative to the amount of the blood constituent present in the blood. The amount of light absorbed and/or scattered may then be used to estimate the amount of blood constituent in the tissue using various algorithms.

[0008] Pulse oximetry readings depend on pulsation of blood through the tissue. Thus, any event that interferes with the ability of the sensor to detect that pulsation can cause variability in these measurements. Motion artifacts occur when a patient's movements cause interference in the signal detected by the sensor. Motion artifacts can also occur in response to forces acting on the sensor. For example, a patient may be jostled by healthcare workers in emergency

room settings. The type location, amount, or duration of force acting on a sensor will determine the nature of the motion artifact.

[0009] Generally, sensors are vulnerable to motion artifacts when the optical distance, or path length, orientation, or angle between a sensor's emitter and detector varies due to an undesired mechanical change in the conformation of the sensor while in use. The mechanical deformation of the sensor may be in the form of a compression of the sensor, causing a decrease in path length. Alternately, a sensor may flex or move in a manner that increases the distance between an emitter and detector, resulting in an increase in path length. In any case, variability in the optical path length due to motion can cause motion artifacts and obscure the desired pulse oximetry signal.

SUMMARY

[0010] Certain aspects commensurate in scope with the originally claimed invention are set forth below. It should be understood that these aspects are presented merely to provide the reader with a brief summary of certain forms that the invention might take and that these aspects are not intended to limit the scope of the invention. Indeed, the invention may encompass a variety of aspects that may not be set forth below.

[0011] There is provided a sensor that includes: a sensor body; at least one sensing element disposed on the sensor body; and a pressure-sensitive structure associated with the sensor body, wherein the pressure-sensitive structure is adapted to provide a feedback related to a pressure applied to the sensor body.

[0012] There is also provided a pulse oximetry system that includes a pulse oximetry monitor and a pulse oximetry sensor adapted to be operatively coupled to the monitor. The sensor includes: a sensor body; at least one sensing element disposed on the sensor body; and a pressure-sensitive structure associated with the sensor body, wherein the pressure-sensitive structure is adapted to provide a feedback related to a pressure applied to the sensor body.

[0013] There is also provided a method of operating a sensor including: emitting light into a tissue with an emitter; detecting the light with a detector; measuring a physiological characteristic based on the detected light; detecting a force experienced by at least one of the emitter and the detector with a force-sensitive sensor; and triggering an alarm when the force is greater than a threshold value.

[0014] There is also provided a method of manufacturing a sensor that includes providing a sensor body on which at least one sensing element is disposed; and providing a pressure-sensitive structure disposed on the sensor body.

[0015] There is also provided a method that includes: acquiring pressure data and oxygen saturation data from a sensor; correlating the acquired pressure data to a set of reference artifact data; and determining if the oxygen saturation data comprises a motion artifact.

BRIEF DESCRIPTION OF THE DRAWINGS

[0016] Advantages of the invention may become apparent upon reading the following detailed description and upon reference to the drawings in which:

[0017] FIG. 1A illustrates a perspective view of an exemplary sensor featuring force-sensitive mesh regions;

[0018] FIG. 1B illustrates a cross-sectional view of the sensor of FIG. 1A applied to a patient digit;

[0019] FIG. 1C illustrates a perspective view of the tissue-contacting surface of the sensor of FIG. 1A;

[0020] FIG. 2 illustrates a perspective view of the sensor of FIG. 1A after deformation of the force-sensitive mesh caused by finger tapping;

[0021] FIG. 3 illustrates a perspective view of the sensor of FIG. 1A after deformation of the force-sensitive mesh caused by finger squeezing at the joint;

[0022] FIG. 4A illustrates a perspective view of an exemplary embodiment of a forehead sensor whereby the force-sensitive mesh is disposed in a region around the emitter and detector;

[0023] FIG. 4B illustrates a perspective view of the sensor of FIG. 4A after deformation of the force-sensitive mesh caused by pressing the sensor against an object;

[0024] FIG. 5A illustrates a cross-sectional view of an exemplary embodiment of a clip-style sensor with force-sensitive foam disposed on the tissue-contacting side of the sensor;

[0025] FIG. 5B illustrates a cross-sectional view of the pulse oximetry sensor of FIG. 5A in which the force-sensitive foam compresses in response to finger motion;

[0026] FIG. 6A illustrates a cross-sectional view of an exemplary embodiment of a sensor with a color-changing force-sensitive structure disposed on the sensor around the joint;

[0027] FIG. 6B illustrates a cross-sectional view of the pulse oximetry sensor of FIG. 6A in which flexing at the joint causes the force-sensitive structure to change from colorless to red;

[0028] FIG. 7 is a flow chart of the alarm trigger responsive to sensor output according to the present invention;

[0029] FIG. 8 is a more detailed flow chart of step 82 from FIG. 7; and

[0030] FIG. 9 illustrates a pulse oximetry system coupled to a multi-parameter patient monitor and a sensor according to embodiments of the present invention.

DETAILED DESCRIPTION OF SPECIFIC EMBODIMENTS

[0031] One or more specific embodiments of the present invention will be described below. In an effort to provide a concise description of these embodiments, not all features of an actual implementation are described in the specification. It should be appreciated that in the development of any such actual implementation, as in any engineering or design project, numerous implementation-specific decisions must be made to achieve the developers' specific goals, such as compliance with system-related and business-related constraints, which may vary from one implementation to another. Moreover, it should be appreciated that such a development effort might be complex and time consuming, but would nevertheless be a routine undertaking of design,

fabrication, and manufacture for those of ordinary skill having the benefit of this disclosure.

[0032] In accordance with the present technique, sensors for pulse oximetry or other applications utilizing spectrophotometry are provided that reduce motion artifacts by correcting for the effects of patient movement and outside forces. For example, sensors are provided that include force-sensitive devices adapted to assess the pressure experienced by a sensor while in use. Further, sensors as provided herein may notify a user that above-normal pressures are being exerted on a sensor, which may prompt relocation of the sensor to a tissue site that is less subject to motion artifacts.

[0033] Motion artifacts in pulse oximetry are often generated by the movement of the sensor relative to the optically probed tissue, which is typically caused by patient movement or other forces acting on the sensor. Because pulse oximetry is often used in settings where it is difficult to prevent patient motion, it is desirable to provide a mechanism for reducing the effects of motion on the pulse oximetry measurement. For example, a squeezing motion by a patient may mechanically deform a sensor, causing the sensor's emitter and detector to temporarily change position relative to one another, resulting in a motion artifact. Similarly, outside forces, such as the mechanical force of an object pressing against a sensor, may also cause mechanical deformation of a sensor and movement of the sensing components.

[0034] It is desirable to account for the effect of forces on a sensor while in use by providing qualitative information indicating to a healthcare provider or other user that an event, such as a patient motion, is occurring that is likely to cause motion artifacts. In other embodiments, it is desirable to quantitatively assess the motion or force acting on a sensor in order to correct the sensor measurements accordingly. For example, a squeezing motion by a finger may be assessed by a sensor 10 as provided herein. The squeezing may mechanically deform a force-sensitive region on a sensor body applied to the finger. The force of squeezing may be converted to an electrical signal that is sent to a monitor in order to assess the force experienced by the sensor and thus correct for the motion of the emitter relative to the detector.

[0035] FIGS. 1A-C illustrate an exemplary bandage-style sensor 10A adapted for use on a digit. The sensor 10A has a force-sensitive structure 12 disposed on the sensor body 16 in a region corresponding to a fingertip region of a digit when the sensor 10A is applied to a digit 18, as shown in FIG. 1B. The sensor 10A, as depicted, also has a force-sensitive structure 14 disposed on the sensor body 16 in a region corresponding to a joint region of the digit 18. The force-sensitive sensors 12 and 14 may be disposed on the sensor body 16 on the surface 20 that does not contact the digit 18 during normal use. As shown in FIG. 1C, the force-sensitive sensors 12 and 14 may be disposed on the surface 20 of the sensor body 16 that opposes the tissue-contacting surface 22 upon which the emitter 24 and the detector 26 are disposed. In alternate embodiments, it is contemplated that the force-sensitive sensors 12 and 14 may be embedded in the sensor body 16 or disposed on the tissue-contacting surface 22.

[0036] The force-sensitive sensors 12 and 14 have input and output leads 28 and 30 respectively, which may be

embedded in the sensor body 16. It is contemplated that the leads 28 and 30 may be connected to a cable 36 that also connects to the electrical lead 32 of the emitter 24 and the electrical lead 34 of the detector 26. As depicted, the force-sensitive sensors 12 and 14 may be flexible mesh-type arrays of multiple sensing elements, or may be flexible circuits.

[0037] In other embodiments, the sensor 10A may have additional force-sensitive sensors disposed on the sensor body 16. It may be advantageous to provide force-sensitive sensors on multiple sides of the sensor 10A, as it is difficult to predict the types of motion that the sensor 10A may experience. For example, force-sensitive sensors may be distributed on the sensor body 16 in locations directly opposing each other across the digit 18. Such an arrangement may provide more complete information about a squeezing motion of the digit 18 at a joint, as a force-sensitive structure on the top of the digit 18 may experience a stretching force while a force-sensitive structure in the crease of the joint may experience a compression force. Further, force-sensitive sensors may be disposed on the sensor body 16 in regions that correspond to the sides of the digit to provide information about the pressure experienced by the sensor body 16 during a rolling motion of the digit 18.

[0038] More specifically, FIG. 2 illustrates a perspective view of the sensor 10A with an exemplary deformation pattern of the force-sensitive structure 12 in response to a finger-tapping or pressing motion. An x-axis 38 and a y-axis 40 correspond to the plane of the sensor body 16. A z-axis 42 corresponds to the direction of pressure from the tapping motion of the digit 18. As the digit 18 presses against the tip of the sensor body 16, the force-sensitive structure 12 is deformed such that certain portions of the mesh form a peak-like structure 19. The deformation in response to pressure may cause certain intersection points in the grid of the force-sensitive structure 12 to be pushed closer together. As the distances between the intersection points change, the force-sensitive structure 12 may convert the change in the distances into an electrical signal that is related to the pressure experienced by the sensor 10A.

[0039] Similarly, FIG. 3 illustrates a perspective view of the sensor 10A with an exemplary deformation pattern of the force-sensitive structure 14 in response to a finger squeezing motion. The z-axis 42 corresponds to the direction of pressure from a squeezing motion of the digit 18. As the digit 18 flexes at the joint, the force-sensitive structure 14 is deformed such that the mesh is compressed. The deformation in response to squeezing may cause certain intersection points in the grid of the force-sensitive structure 14 to be pushed closer together. As above, the change in the distance between intersection points of the grid of the force-sensitive structure may be converted into an electrical signal.

[0040] It is also contemplated that a force-sensitive structure may be disposed on a sensor body in a region corresponding to at least one of an emitter or a detector. FIG. 4A illustrates a reflectance-type sensor 10B adapted for use on a patient's forehead. The sensor 10B has a force-sensitive structure 44 disposed on a tissue-contacting surface 45 of 10 the sensor body 50. The emitter 46 and the detector 48 are surrounded by the force-sensitive structure 44, which deforms in response to outside forces, thereby providing a measure of the outside forces acting upon the emitter 46 and

the detector 48. FIG. 4B illustrates an exemplary deformation of the force-sensitive structure 44 as it may appear after a patient has pressed the sensor 10B against a pillow or other object during normal wear.

[0041] Force-sensitive sensors as described herein may be any appropriate sensor that is capable of converting a force applied to a sensor body into an electrical signal. In certain embodiments, the pressure or force-sensitive structure may take the form of a displacement sensor. In one such embodiment, the pressure or force-sensitive structure may include a strain gauge or other mechanical displacement sensor. In another embodiment, the displacement sensor may include a linear variable differential transformer. In other embodiments, a force-sensitive structure may be a resistance-based sensor. Force-sensitive sensors, e.g. sensors 12, 14, and 44 may be disposed on the sensor body as electrodes, such as silver electrodes, printed as a matrix of intersecting rows and columns. An additional layer of semiconductive ink may provide an electrical resistance at each intersection on the matrix. Sandwiching these two layers together may create an array sensor. When a force is applied, the change in resistance is measured. Changing the formulation of the ink may produce different sensitivity ranges. Additionally, varying the spacing between rows and columns may yield finer resolution. In certain embodiments, a force-sensitive structure may have a spatial resolution, or sensor electrode spacing, of at least 0.0229 mm^2 . An example of a resistance sensor that is appropriate for use with a sensor 10 according to the present techniques is Flexiforce® film or flexible circuits, available from Tekscan (South Boston, MA).

[0042] Pressure measurements may also be made by using polymers that are force-sensitive resistor materials. Force-sensitive resistor materials, such as those available from Interlink (Carpenteria, CA) and Advanced Composites Technology (Boston, MA) have a resistance variation under load. A force sensing resistor may be a piezoresistivity conductive polymer, which changes resistance in a predictable manner following application of force to its surface. It is normally supplied as a polymer sheet which has had the sensing film applied by screen printing. The sensing film typically includes both electrically conducting and non-conducting particles suspended in matrix. The particle sizes may be of the order of fraction of microns, and the particles may be formulated to reduce the temperature dependence, improve mechanical properties and increase surface durability. Applying a force to the surface of the sensing film causes particles to touch the conducting electrodes, changing the resistance of the film. Such a polymer-based force-sensitive resistor may be advantageous as it utilizes a relatively simple interface and can operate satisfactorily in moderately hostile environments.

[0043] In certain embodiments, the pressure or force-sensitive structure may take the form of a capacitance sensor. In such sensors, the capacitance is inversely proportional to the distance between the electrodes of the sensor. An exemplary capacitance-based sensor, TactArray, is available from Pressure Profile Systems (Los Angeles, CA). In certain embodiments, the capacitance sensor may be sensitive to forces or pressures from 1 psi to 200 psi.

[0044] In a specific embodiment, it may be advantageous to provide a mechanism for monitoring movement of a digit within a relatively rigid clip-style sensor. FIGS. 5A-B illus-

trate a sensor 10C that includes an elastomeric foam that is sensitive to force. The force-sensitive foam 52 provides measurement of the resistance of a conductive elastomer or foam between two points. The force-sensitive foam may be a carbon doped rubber in which the resistance of the elastomer changes with the application of force, resulting from the deformation of the elastomer altering the particle density. As depicted, the force-sensitive foam is disposed on the tissue-contacting surface 54 of the sensor body 56. As the digit 58 moves within the sensor 10C, the foam is compressed, resulting in a change in the resistance of the foam. The electrical signal generated by the movement of the digit may be further processed to correct for any motion artifacts caused by the movement of the digit relative to the sensor 10C.

[0045] In certain embodiments, it is envisioned that force or pressure data generated from the force-sensitive structures may be further processed to generate displays or other information related to a sensor 10 condition. However, as patients may not be familiar with the medical monitor icons and displays that may be used in conjunction with a sensor 10, in certain embodiments it may be advantageous to provide a sensor 10 with a force-sensitive signal that is easily identifiable by a patient. FIG. 6A illustrates a sensor 10D applied to a patient digit 60. The sensor 10D includes a force-sensitive structure 62 disposed on the surface 64 of the sensor body 66 that does not contact the digit during normal use. The force-sensitive structure 62 is adapted to change color upon the application of force. As illustrated in FIG. 6B, upon squeezing of the digit 60 at the first joint, the force-sensitive structure 62 changes color from colorless to red as pressure increased in the area of the force-sensitive structure 62. The force-sensitive structure 62 may be Pressurex® film, available from Sensor Products Inc. (East Hanover, N.J.), which increases in red color intensity in relation to the amount of force applied. A conscious patient may easily note the change in color and adjust his actions to prevent further movements that may be associated with motion artifacts and measurement errors.

[0046] It is envisioned that a sensor 10 as described herein may be used to provide information related to the pressure and forces experienced by the sensor 10 during use. Such information may be converted into an electrical signal and sent to a monitor or another appropriate device, as described in more detail below, for processing. The flow chart 68 depicted in FIG. 7 describes the downstream steps involved after step 70, which involves acquisition of the oxygen saturation data 74 from the sensor 10, and step 72, which involves acquisition of force or pressure data 76. In certain embodiments, it is envisioned that steps 70 and 72 may occur simultaneously.

[0047] At a step 78, a processor compares the pressure data 76 against a pressure threshold. Generally, the raw pressure data 76 output from a force-sensitive structure as described herein is further acted upon by a processor, such as a processor in a pulse oximeter, to provide either a pressure map or a pressure value. As a sensor 10 may provide separate pressure outputs from multiple force-sensitive structures, it may be advantageous to provide a map of the pressure variations at different locations on the sensor body. In other embodiments, it may be appropriate to provide a measure of the total pressure experienced by the sensor body, or the total pressure experienced at a single

location, such as a fingertip location. The map or value may then be compared to a predetermined threshold map or predetermined threshold value. The threshold value is generally envisioned to be a pressure value that is associated with an increase in motion artifacts. A threshold map may be an image which may be directly compared to a pressure map obtained from the force-sensitive structure. If, at a step 78, the pressure data 76 does not exceed a predetermined threshold value, the processor passes control to step 80. At step 80, the system goes into a default mode and a processor calculates an oxygen saturation value from the oxygen saturation data 74. The oxygen saturation value may then be displayed on a monitor.

[0048] If, on the other hand, the pressure data 76 does exceed a threshold pressure value, the processor passes control to steps 82 and 84. In step 84, a notification is displayed to alert a user that the pressure experienced by a sensor 10 has increased beyond a critical threshold value. The notification may be an audio alarm, such as a warning sound, or a visual alarm, such as a text message or icon that is displayed on a monitor.

[0049] In step 82, a processor may act upon the oxygen saturation data 74 in order to correct for any influence of higher-than-normal pressures on the sensor 10. The corrected oxygen saturation value may then be displayed on the monitor. For example, a processor may adjust an estimation of the path length between an emitter and a detector to account for any reduction in the path length due to tissue compression. In such an example, measured pressure would be inversely related to path length. The adjustment of the path length may result in a correction in the oxygen saturation.

[0050] In another embodiment, shown in FIG. 8, step 82 may be accomplished by correlating pressure data 76 to previously acquired or reference artifact data characteristic of different pressure events. At step 104, the pressure data 76 exceeding a pre-defined threshold at step 78 is provided as input into a searchable machine-readable database of artifact data to determine if the pressure data 76 is characteristic of particular artifact events. The look-up database of artifact in step 104 may be acquired through measurements of various pressure profiles associated with artifact events to build a look-up database or table that correlates pressure data 76 with possible artifact/interference-related saturation data. For example, the pressure data 76 may be compared to an artifact database in step 104 to determine if the pressure data 76 is characteristic of venous pooling under the fingertip during tapping or compartmentalization of blood in the finger during scratching. The oxygen saturation data 74 may then be corrected in light of the particular type of pressure experienced by the tissue. The database artifact/interference data obtained from step 104 that correlates with or is characteristic of the pressure data 76 is analyzed in frequency domain at step 106 using frequency transforms such as FFT (Fast Fourier Transform) and WT (Wavelet Transform). Additionally in step 106, frequency transforms are also applied to the acquired raw saturation data 74. At certain frequencies where found artifacts/interferences are located, the artifacts/interferences may be removed from saturation data in the frequency domain. The resultant corrected frequency domain saturation data (with artifact/interference removed) may then be used to reconstruct the clean time domain saturation signal via inverse transforms

such as inverse FFT and inverse wavelet transform at step 108. The reconstructed oxygen saturation data may then be displayed in step 86.

[0051] In another embodiment (not shown), a sensor 10 may include a second emitter and detector pair located in a different position on the sensor body than the first emitter and detector pair. At step 78, a processor may note that pressure data 76 from the first emitter and detector pair exceeds a threshold pressure value. The processor may then pass control to the second emitter and detector pair, which may be located at a site that experiences pressures below the threshold pressure value. In an alternate embodiment (not shown), a sensor 10 may include an emitter and first detector located in a different position on the sensor body than a second detector. At step 78, a processor may note that pressure data 76 from the first emitter and first detector exceeds a threshold pressure value, and the processor may pass control to the second detector.

[0052] A sensor, illustrated generically as a sensor 10, may be used in conjunction with a pulse oximetry monitor 88, as illustrated in FIG. 9. It should be appreciated that the cable 90 of the sensor 10 may be coupled to the monitor 88 or it may be coupled to a transmission device (not shown) to facilitate wireless transmission between the sensor 10 and the monitor 88. The monitor 88 may be any suitable pulse oximeter, such as those available from Nellcor Puritan Bennett Inc. Furthermore, to upgrade conventional pulse oximetry provided by the monitor 88 to provide additional functions, the monitor 88 may be coupled to a multi-parameter patient monitor 92 via a cable 94 connected to a sensor input port or via a cable 96 connected to a digital communication port.

[0053] The sensor 10 includes an emitter 98 and a detector 100 that may be of any suitable type. For example, the emitter 98 may be one or more light emitting diodes adapted to transmit one or more wavelengths of light in the red to infrared range, and the detector 100 may be one or more photodetectors selected to receive light in the range or ranges emitted from the emitter 98. Alternatively, an emitter 98 may also be a laser diode or a vertical cavity surface emitting laser (VCSEL). An emitter 98 and detector 100 may also include optical fiber sensing elements. An emitter 98 may include a broadband or "white light" source, in which case the detector could include any of a variety of elements for selecting specific wavelengths, such as reflective or refractive elements or interferometers. These kinds of emitters and/or detectors would typically be coupled to the rigid or rigidified sensor via fiber optics. Alternatively, a sensor 10 may sense light detected from the tissue at a different wavelength from the light emitted into the tissue. Such sensors may be adapted to sense fluorescence, phosphorescence, Raman scattering, Rayleigh scattering and multi-photon events or photoacoustic effects. For pulse oximetry applications using either transmission or reflectance type sensors the oxygen saturation of the patient's arterial blood may be determined using two or more wavelengths of light, most commonly red and near infrared wavelengths. Similarly, in other applications, a tissue water fraction (or other body fluid related metric) or a concentration of one or more biochemical components in an aqueous environment may be measured using two or more wavelengths of light, most commonly near infrared wavelengths between about 1,000 nm to about 2,500 nm. It should be understood that, as used

herein, the term "light" may refer to one or more of ultrasound, radio, microwave, millimeter wave, infrared, visible, ultraviolet, gamma ray or X-ray electromagnetic radiation, and may also include any wavelength within the radio, microwave, infrared, visible, ultraviolet, or X-ray spectra.

[0054] The emitter 98 and the detector 100 may be disposed on a sensor body 102, which may be made of any suitable material, such as plastic, foam, woven material, or paper. Alternatively, the emitter 98 and the detector 100 may be remotely located and optically coupled to the sensor 10 using optical fibers. In the depicted embodiments, the sensor 10 is coupled to a cable 90 that is responsible for transmitting electrical and/or optical signals to and from the emitter 98 and detector 100 of the sensor 10. The cable 90 may be permanently coupled to the sensor 10, or it may be removably coupled to the sensor 10—the latter alternative being more useful and cost efficient in situations where the sensor 10 is disposable.

[0055] The sensor 10 may be a "transmission type" sensor. Transmission type sensors include an emitter 98 and detector 100 that are typically placed on opposing sides of the sensor site. If the sensor site is a fingertip, for example, the sensor 10 is positioned over the patient's fingertip such that the emitter 98 and detector 100 lie on either side of the patient's nail bed. In other words, the sensor 10 is positioned so that the emitter 98 is located on the patient's fingernail and the detector 100 is located 180° opposite the emitter 98 on the patient's finger pad. During operation, the emitter 98 shines one or more wavelengths of light through the patient's fingertip and the light received by the detector 100 is processed to determine various physiological characteristics of the patient. In each of the embodiments discussed herein, it should be understood that the locations of the emitter 98 and the detector 100 may be exchanged. For example, the detector 100 may be located at the top of the finger and the emitter 98 may be located underneath the finger. In either arrangement, the sensor 10 will perform in substantially the same manner.

[0056] Reflectance type sensors also operate by emitting light into the tissue and detecting the light that is transmitted and scattered by the tissue. However, reflectance type sensors include an emitter 98 and detector 100 that are typically placed on the same side of the sensor site. For example, a reflectance type sensor may be placed on a patient's fingertip or forehead such that the emitter 98 and detector 100 lie side-by-side. Reflectance type sensors detect light photons that are scattered back to the detector 100. A sensor 10 may also be a "transflectance" sensor, such as a sensor that may subtend a portion of a baby's heel.

[0057] While the invention may be susceptible to various modifications and alternative forms, specific embodiments have been shown by way of example in the drawings and have been described in detail herein. However, it should be understood that the invention is not intended to be limited to the particular forms disclosed. Indeed, the present techniques may not only be applied to measurements of blood oxygen saturation, but these techniques may also be utilized for the measurement and/or analysis of other blood constituents. For example, using the same, different, or additional wavelengths, the present techniques may be utilized for the measurement and/or analysis of carboxyhemoglobin, met-

hemoglobin, total hemoglobin, fractional hemoglobin, intravascular dyes, and/or water content. Rather, the invention is to cover all modifications, equivalents, and alternatives falling within the spirit and scope of the invention as defined by the following appended claims

What is claimed is:

1. A sensor comprising:
 - a sensor body;
 - at least one sensing element disposed on the sensor body; and
 - a pressure-sensitive structure associated with the sensor body, wherein the pressure-sensitive structure is adapted to provide a feedback related to a pressure applied to the sensor body.
2. The sensor, as set forth in claim 1, wherein the sensor comprises at least one of a pulse oximetry sensor or a sensor for measuring a water fraction.
3. The sensor, as set forth in claim 1, wherein the sensing element comprises an emitter and a detector.
4. The sensor, as set forth in claim 3, wherein the emitter comprises at least one light emitting diode and the detector comprises at least one photodetector.
5. The sensor, as set forth in claim 1, wherein the feedback comprises an electrical signal.
6. The sensor, as set forth in claim 1, wherein the wherein the pressure-sensitive structure comprises a capacitance-based sensor or a resistance-based sensor.
7. The sensor, as set forth in claim 1, wherein the wherein the pressure-sensitive structure comprises a displacement-based sensor.
8. The sensor, as set forth in claim 1, wherein the pressure-sensitive structure is conformable.
9. The sensor, as set forth in claim 1, wherein the pressure-sensitive structure comprises an array of pressure sensors.
10. The sensor, as set forth in claim 1, wherein the pressure-sensitive structure is disposed on the surface of the sensor body that does not contact a patient's tissue during normal use.
11. The sensor, as set forth in claim 1, wherein the sensor comprises a bandage-type sensor.
12. A pulse oximetry system comprising:
 - a pulse oximetry monitor; and
 - a pulse oximetry sensor adapted to be operatively coupled to the monitor, the sensor comprising:
 - a sensor body;
 - at least one sensing element disposed on the sensor body; and
 - a pressure-sensitive structure associated with the sensor body, wherein the pressure-sensitive structure is adapted to provide a feedback related to a pressure applied to the sensor body.
13. The system, as set forth in claim 12, wherein the sensor comprises at least one of a pulse oximetry sensor or a sensor for measuring a water fraction.
14. The system, as set forth in claim 12, wherein the sensing element comprises an emitter and a detector.
15. The system, as set forth in claim 14, wherein the emitter comprises at least one light emitting diode and the detector comprises at least one photodetector.
16. The system, as set forth in claim 12, wherein the feedback comprises an electrical signal.
17. The system, as set forth in claim 12, wherein the wherein the pressure-sensitive structure comprises a capacitance-based sensor or a resistance-based sensor.
18. The system, as set forth in claim 12, wherein the wherein the pressure-sensitive structure comprises a displacement-based sensor.
19. The system, as set forth in claim 12, wherein the pressure-sensitive structure is conformable.
20. The system, as set forth in claim 12, wherein the pressure-sensitive structure comprises an array of pressure sensors.
21. The system, as set forth in claim 12, wherein the pressure-sensitive structure is disposed on the surface of the sensor body that does not contact a patient's tissue during normal use.
22. The system, as set forth in claim 12, wherein the sensor comprises a bandage-type sensor.
23. The system, as set forth in claim 12, wherein the monitor is adapted to provide an indication related to the pressure feedback.
24. The system, as set forth in claim 23, wherein the indication comprises an alarm.
25. The system, as set forth in claim 24, wherein the alarm comprises at least one of a visual alarm or an audio alarm.
26. The system, as set forth in claim 24, wherein the indication comprises a corrected pulse oximetry measurement.
27. The system, as set forth in claim 12, comprising reference artifact data stored on a machine-readable medium.
28. The system, as set forth in claim 27, wherein the reference artifact data comprises clinical artifact data.
29. The system, as set forth in claim 12, wherein the system comprises a digital signal processing module.
30. A method comprising:
 - emitting light into a tissue with an emitter;
 - detecting the light with a detector;
 - measuring a physiological characteristic based on the detected light;
 - detecting a force experienced by at least one of the emitter and the detector with a force-sensitive sensor; and
 - triggering an alarm when the force is greater than a threshold value.
31. The method, as set forth in claim 30, wherein detecting the force comprises detecting a change in capacitance or a change in resistance.
32. The method, as set forth in claim 30, wherein detecting the force comprises detecting displacement.
33. The method, as set forth in claim 30, wherein triggering the alarm comprises emitting an audio signal.
34. The method, as set forth in claim 30, wherein triggering the alarm comprises emitting a visual signal.
35. The method, as set forth in claim 30, comprising emitting light from a second emitter and detecting the light with a second detector when the force is greater than a threshold value.
36. The method, as set forth in claim 30, comprising detecting the light with a second detector when the force is greater than a threshold value.

37. The method, as set forth in claim 30, comprising correcting the measurement of the blood constituent when the force is greater than a threshold value.

38. The method, as set forth in claim 37, wherein correcting the measurement of the blood constituent comprises correcting the estimated path length between the emitter and the detector.

39. The method, as set forth in claim 37, wherein correcting the measurement of the blood constituent comprises comparing the force experienced by the emitter and the detector to a set of previously acquired force data.

40. The method, as set forth in claim 39, wherein the set of previously acquired force data comprises force data characteristic of scratching or tapping.

41. A method of manufacturing a sensor, comprising:

providing a sensor body on which at least one sensing element is disposed; and

providing a pressure-sensitive structure disposed on the sensor body.

42. The method, as set forth in claim 41, wherein the sensor comprises at least one of a pulse oximetry sensor or a sensor for measuring a water fraction.

43. The method, as set forth in claim 41, wherein providing the sensing element comprises providing an emitter and a detector.

44. The method, as set forth in claim 43, wherein providing the emitter comprises providing one or more light emitting diodes and providing the detector comprises providing one or more photodetectors.

45. The method, as set forth in claim 41, wherein providing the pressure-sensitive structure comprises providing a capacitance-based sensor or a resistance-based sensor.

46. The method, as set forth in claim 41, wherein providing the pressure-sensitive structure comprises providing a displacement-based sensor.

47. A method comprising:

acquiring pressure data and oxygen saturation data from a sensor;

correlating the acquired pressure data to a set of reference artifact data; and

determining if the oxygen saturation data comprises a motion artifact.

48. The method, as set forth in claim 47, wherein correlating the acquired pressure data with the reference artifact data comprises a look-up process that operates on the reference artifact data to generate input to a digital signal processing module.

* * * * *

专利名称(译)	医疗传感器及其使用技术		
公开(公告)号	US20070078316A1	公开(公告)日	2007-04-05
申请号	US11/240682	申请日	2005-09-30
[标]申请(专利权)人(译)	HOARAU CARINE 李莉		
申请(专利权)人(译)	HOARAU CARINE 李丽		
当前申请(专利权)人(译)	COVIDIEN LP		
[标]发明人	HOARAU CARINE LI LI		
发明人	HOARAU, CARINE LI, LI		
IPC分类号	A61B5/00		
CPC分类号	A61B5/14552 A61B5/6826 A61B5/6838		
其他公开文献	US7483731		
外部链接	Espacenet USPTO		

摘要(译)

传感器可以适于提供输出以指示传感器何时经历异常力或压力。力可以是外力，或者力可以通过患者运动产生。所提供的传感器系统还可以适于在计算与生理特征相关的测量值时校正这种力。

