



US007704211B1

(12) **United States Patent**
Koh

(10) **Patent No.:** **US 7,704,211 B1**
(45) **Date of Patent:** **Apr. 27, 2010**

(54) **METHOD AND APPARATUS FOR ASSESSING FLUID LEVEL IN LUNGS**

(75) Inventor: **Steve Koh**, South Pasadena, CA (US)

(73) Assignee: **Pacesetter, Inc.**, Sylmar, CA (US)

(*) Notice: Subject to any disclaimer, the term of this patent is extended or adjusted under 35 U.S.C. 154(b) by 1167 days.

(21) Appl. No.: **11/086,612**

(22) Filed: **Mar. 21, 2005**

(51) **Int. Cl.**
A61B 5/02 (2006.01)
A61B 5/08 (2006.01)
A61B 5/00 (2006.01)

(52) **U.S. Cl.** 600/486; 600/532; 600/300

(58) **Field of Classification Search** 128/200.24, 128/204.18, 204.21, 204.23; 600/547, 529, 600/518, 534, 527, 484, 509; 607/9, 17-20, 607/32, 59, 60, 62, 4-6

See application file for complete search history.

(56) **References Cited**

U.S. PATENT DOCUMENTS

4,648,407	A *	3/1987	Sackner	600/534
5,876,353	A *	3/1999	Riff	600/547
5,911,218	A *	6/1999	DiMarco	128/200.24
6,015,388	A *	1/2000	Sackner et al.	600/529
6,473,640	B1	10/2002	Erlebacher	600/547
6,512,949	B1	1/2003	Combs et al.	600/547
6,595,927	B2	7/2003	Pitts-Crick et al.	600/529

6,600,949	B1 *	7/2003	Turcott	600/518
6,641,542	B2 *	11/2003	Cho et al.	600/529
7,396,333	B2 *	7/2008	Stahmann et al.	600/529
2003/0023184	A1	1/2003	Pitts-Crick et al.	600/547
2005/0085734	A1 *	4/2005	Tehrani	600/484
2005/0085866	A1 *	4/2005	Tehrani	607/42
2006/0247546	A1 *	11/2006	Imose	600/513

FOREIGN PATENT DOCUMENTS

EP	1 238 630	A2	9/2002
EP	1 238 630	A3	9/2002
WO	WO 98/33553		8/1998
WO	WO 98/33554		8/1998

OTHER PUBLICATIONS

Khoo, M.C.K., "Understanding the Dynamics of State-Respiratory Interaction During Sleep," Bioengineering Approaches to Pulmonary Physiology and Medicine, Plenum Press, New York (1996); p. 7.

* cited by examiner

Primary Examiner—Steven O Douglas

Assistant Examiner—Annette F Dixon

(57) **ABSTRACT**

The invention relates to an apparatus and method to assess the fluid level in lungs. An implantable medical device or external monitor is used to sense or monitor the patient's respiratory patterns to identify the presence of periodic breathing or Cheyne-Stokes Respiration (CSR) which is common in patients with congestive heart failure. A fluid index is used to assess the severity of congestive heart failure in a patient. A ratio of Δ blood gas/ Σ total lung volume can be used to determine the lung fluid index.

15 Claims, 8 Drawing Sheets

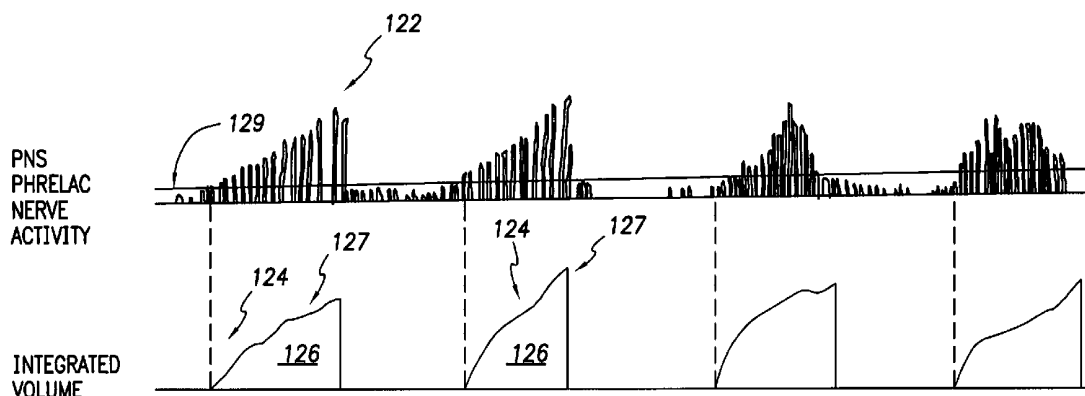

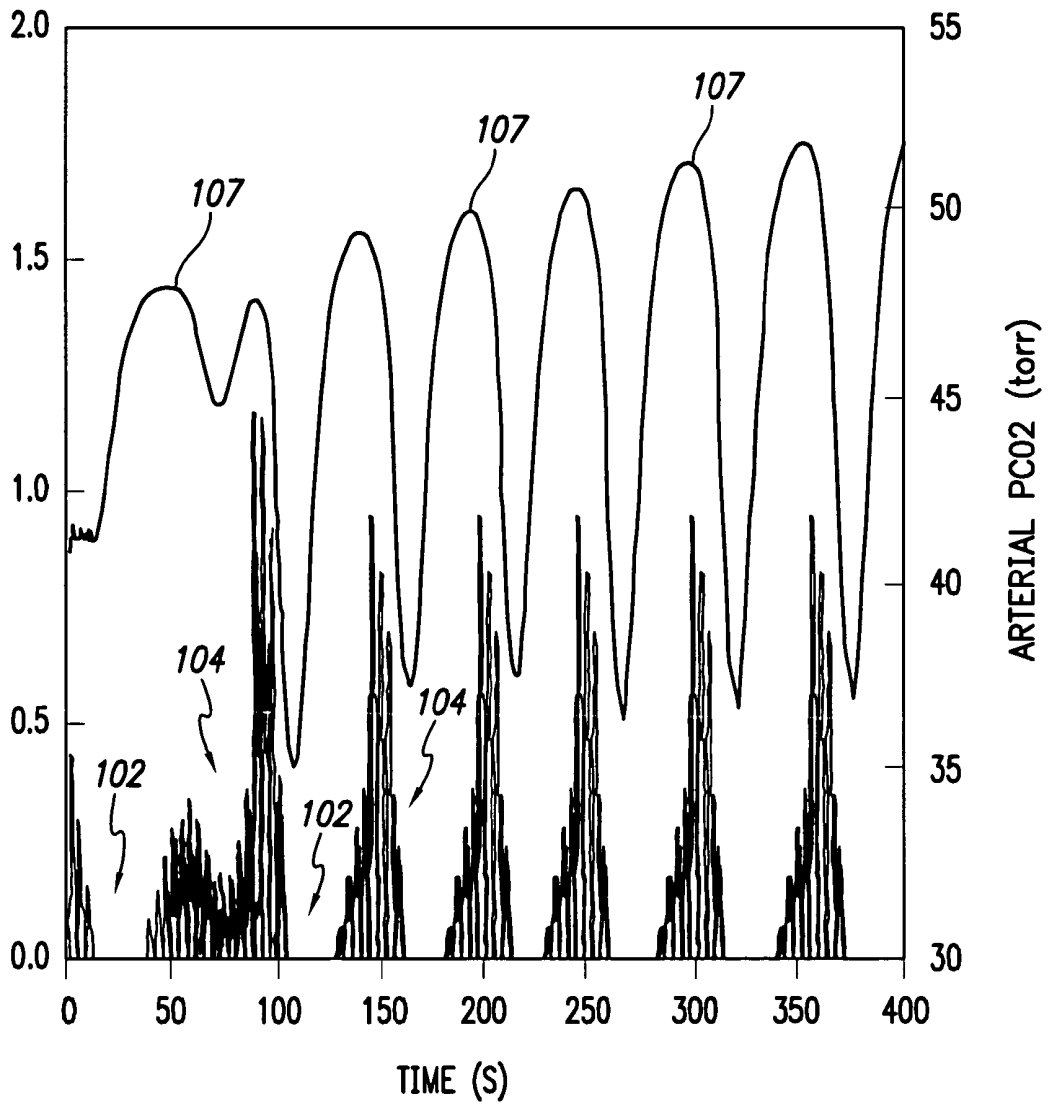

FIG. 1A

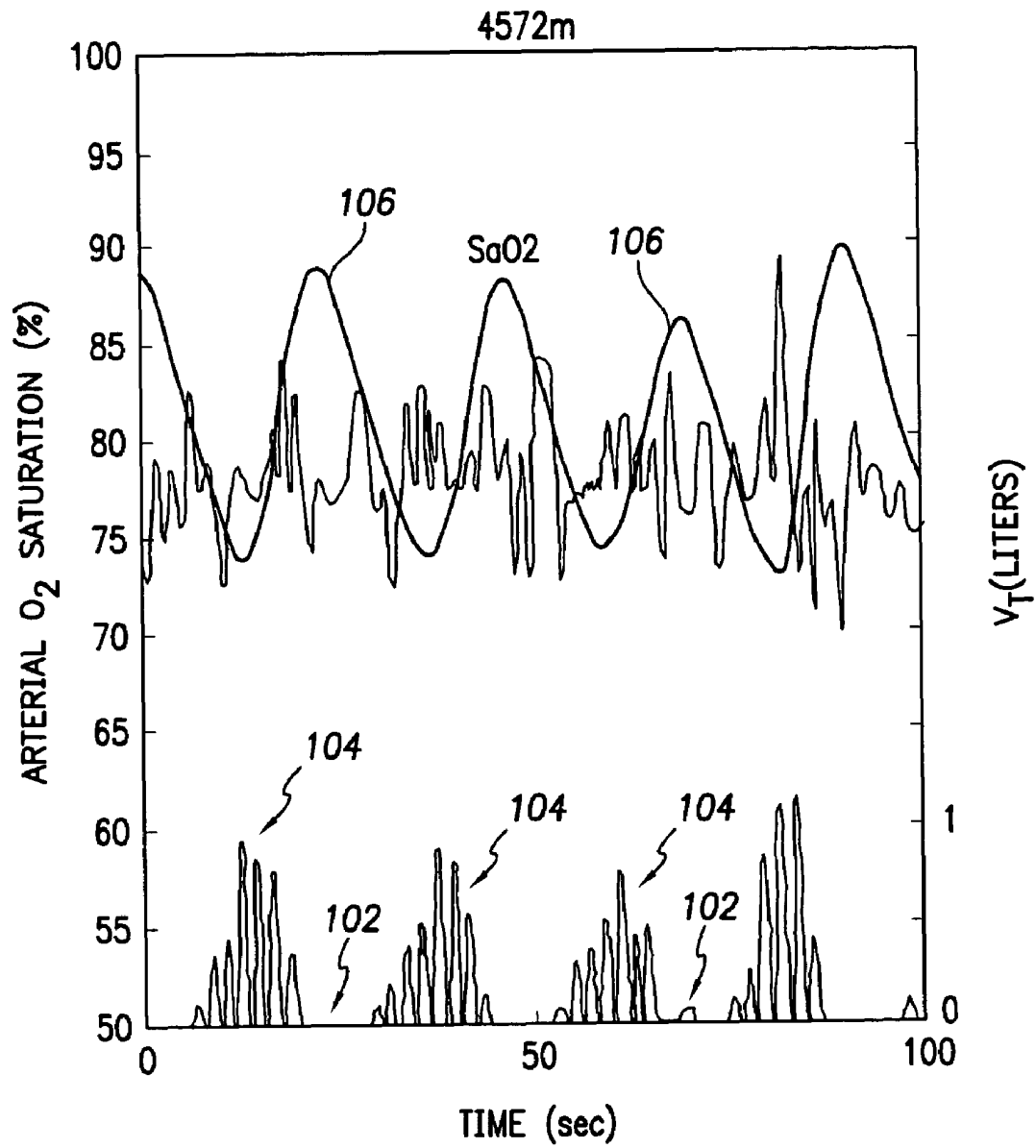

FIG. 1B

FIG. 2A

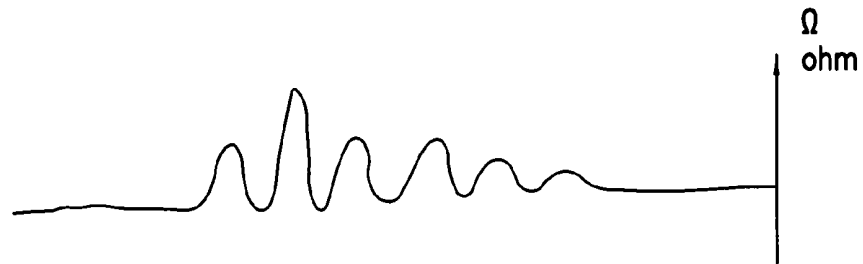

FIG. 2B

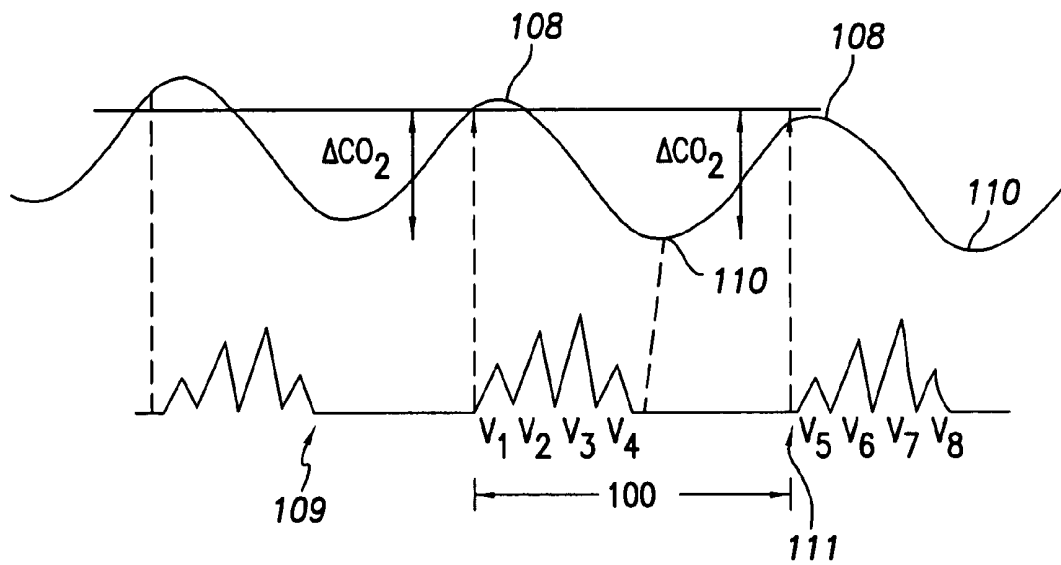

FIG. 3

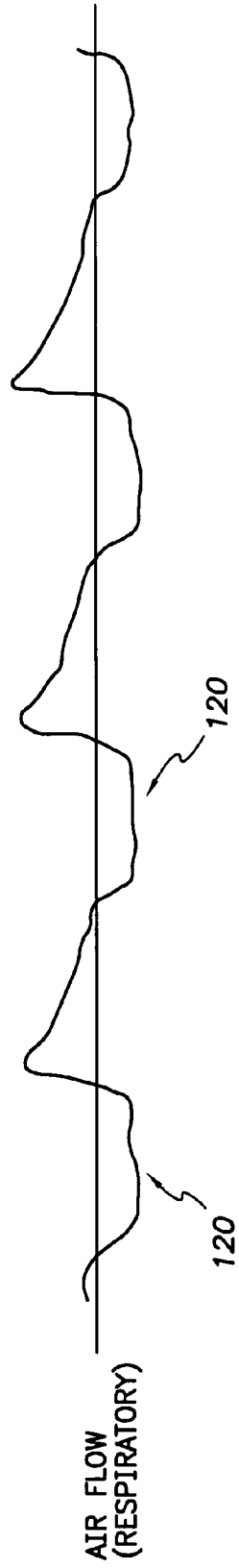
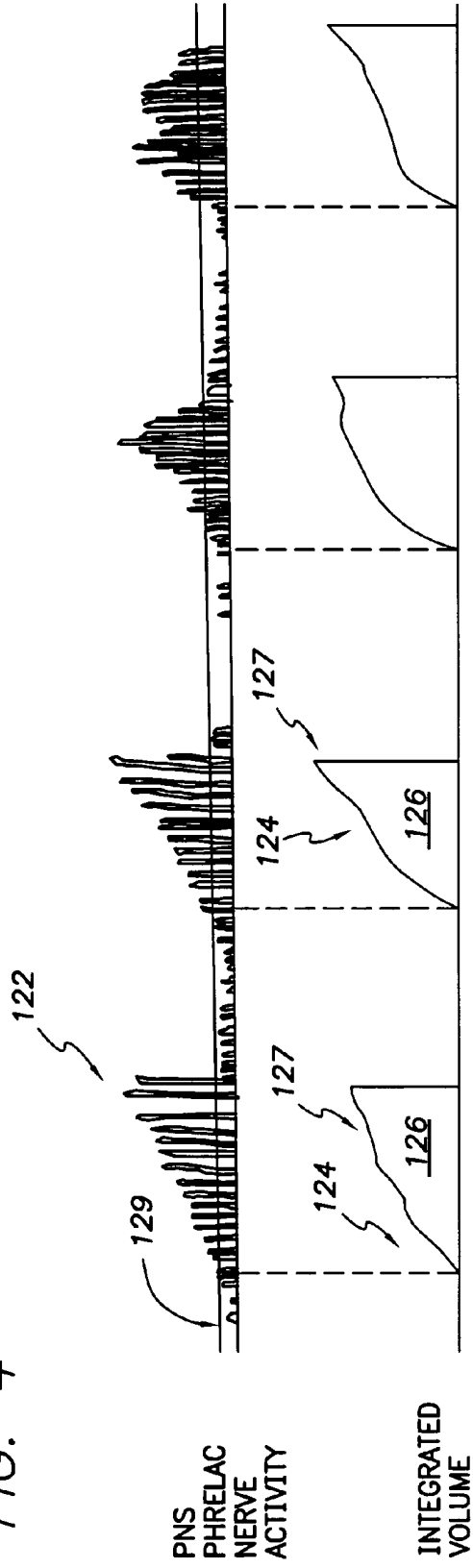

FIG. 4



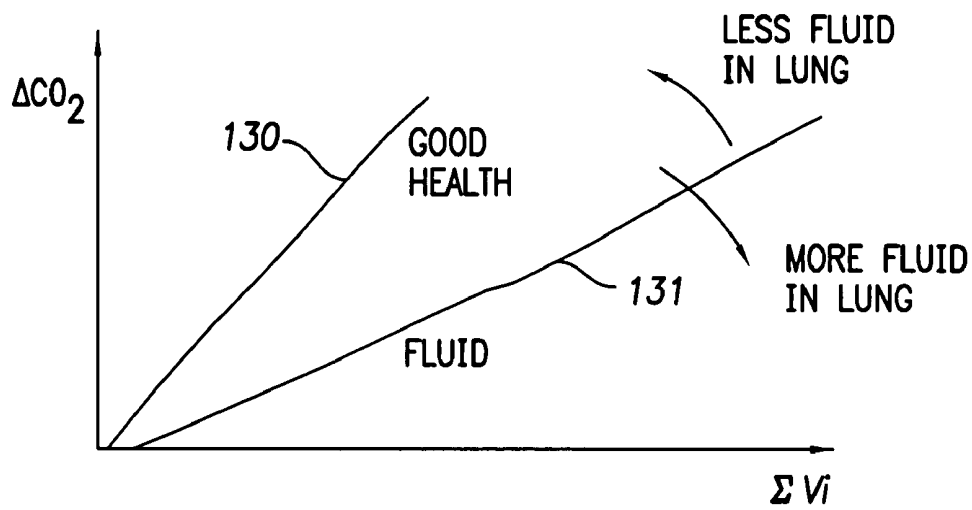

FIG. 5A

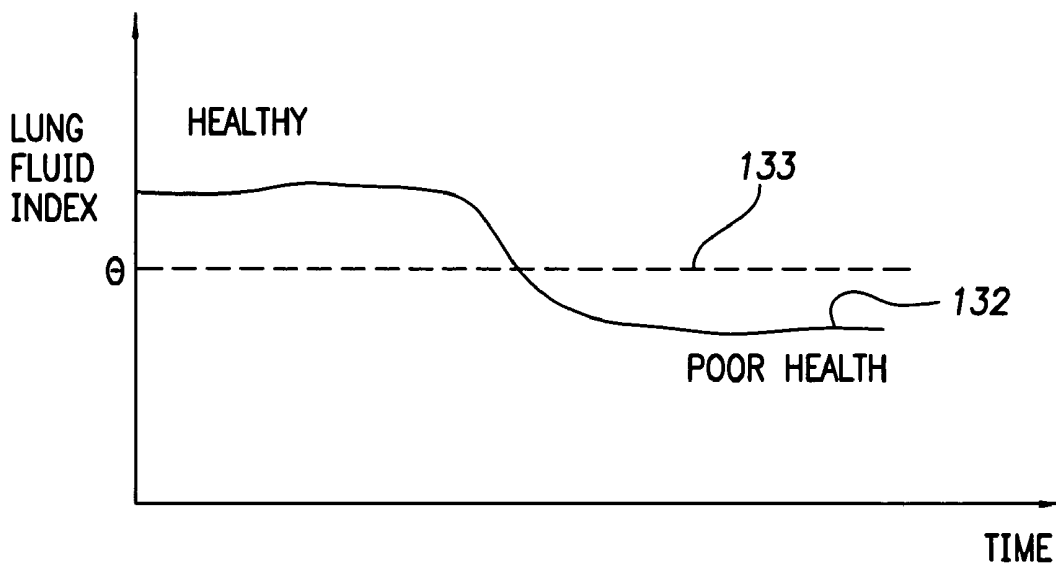

FIG. 5B

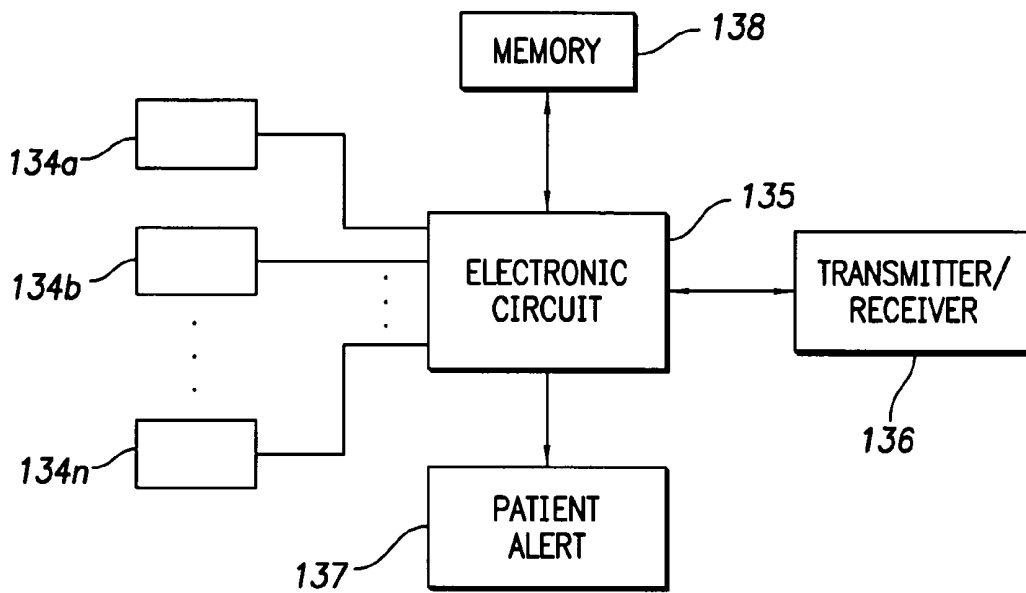

FIG. 6

FIG. 7

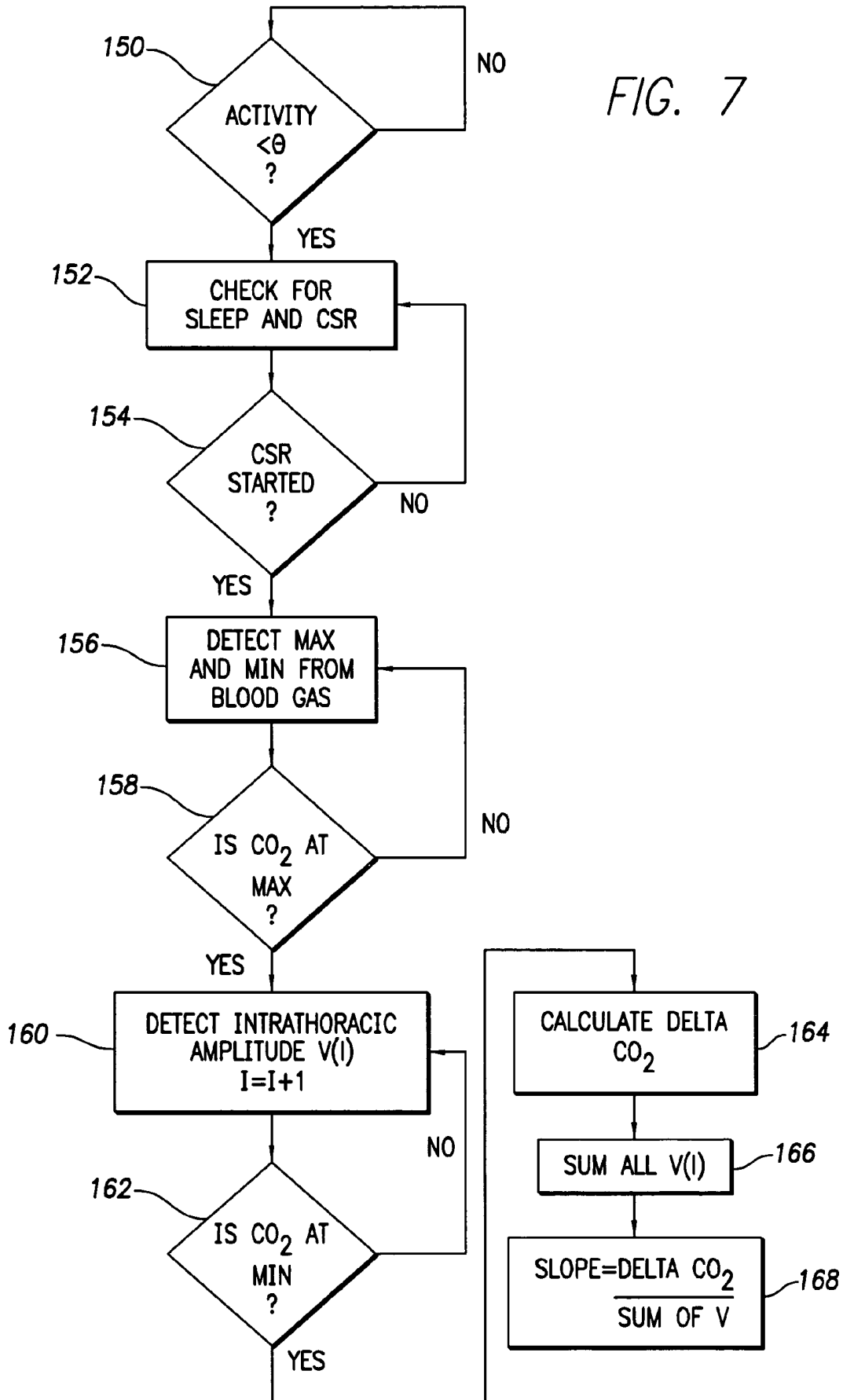
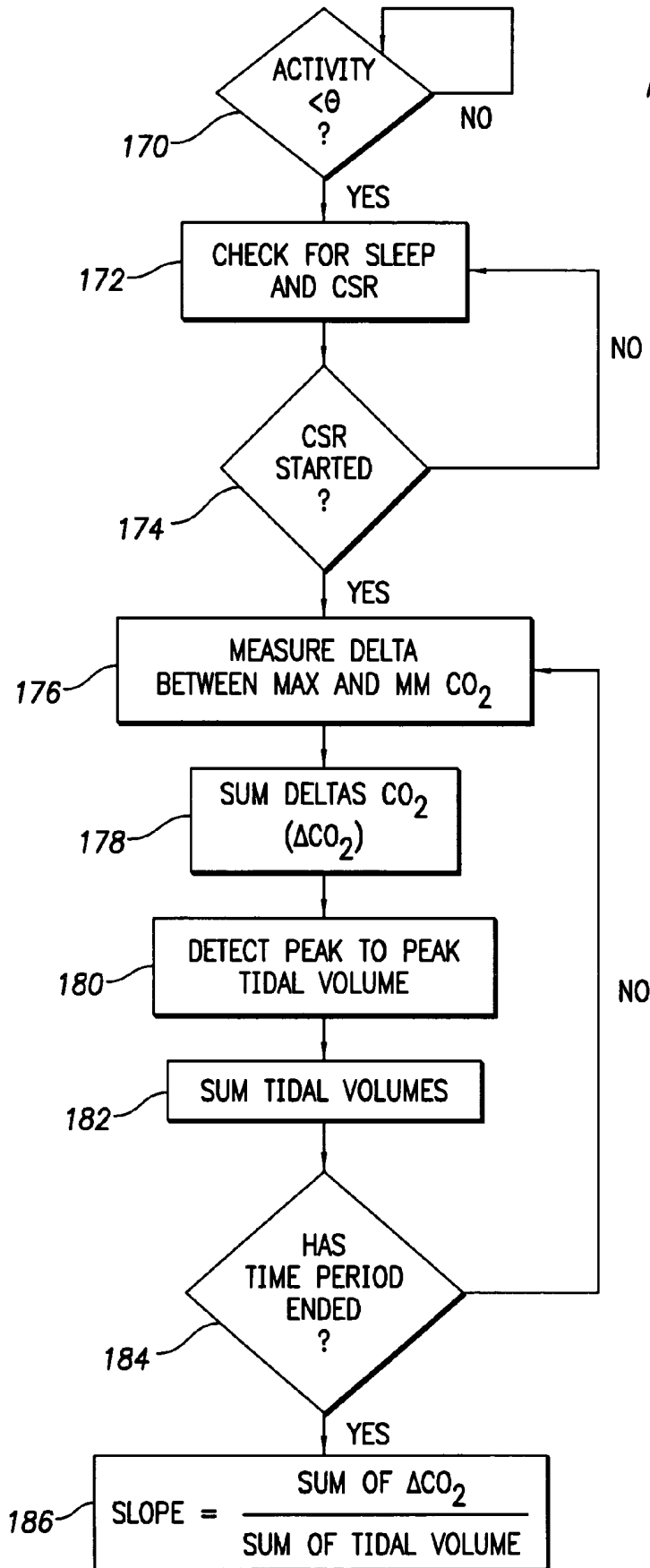

FIG. 8



METHOD AND APPARATUS FOR ASSESSING FLUID LEVEL IN LUNGS

FIELD OF THE INVENTION

The invention relates to patient monitoring, and more particularly, to assessing the severity of the fluid level in the lungs.

BACKGROUND

One common form of central sleep apnea, commonly known as Cheyne-Stokes respiration (CSR), is generally a breathing pattern that is first shallow and infrequent and then gradually increases to become abnormally deep and rapid, before fading away completely for a brief period. Breathing may be stopped for an extended period before the next cycle of shallow breathing begins. CSR is common in patients with congestive heart failure. Common symptoms of congestive heart failure (CHF) are shortness of breath and chest pain. These symptoms occur as a result of decreased cardiac output as well as a decreased gas exchange area due to fluid in the lungs.

Heart failure is a disease of the cardiac mechanical system: it is primarily a failure of the myocardium to meet the mechanical pumping demands required of it. In monitoring the status of a heart failure patient, measuring the mechanical hemodynamic variables is clearly desirable. However, because of the complex feedback network that monitors and controls cardiac performance, measuring variables that do not directly reflect the mechanical performance of the heart is also useful. Recognition of Cheyne-Stokes respiration via respiratory pattern analysis, hemoglobin saturation analysis, and blood gas analysis allows one to detect the presence of pulmonary edema, and thereby detect an acute heart failure exacerbation.

Many chronic diseases, such as diabetes and heart failure, require close medical management to reduce morbidity and mortality. Because the disease status evolves with time, frequent physician follow-up examinations are often necessary. At follow-up, the physician may make adjustments to the drug regimen in order to optimize therapy. This conventional approach of periodic follow-up is unsatisfactory for some diseases, such as heart failure, in which acute, life-threatening exacerbations can develop between physician follow-up examinations. It is well known among clinicians that if a developing exacerbation is recognized early, it can be easily and inexpensively terminated, typically with a modest increase in oral diuretic. However, if it develops beyond the initial phase, an acute heart failure exacerbation becomes difficult to control and terminate. Hospitalization in an intensive care unit is often required. It is during an acute exacerbation of heart failure that many patients succumb to the disease. It is often difficult for patients to subjectively recognize a developing exacerbation, despite the presence of numerous physical signs that would allow a physician to readily detect it. Furthermore, since exacerbations typically develop over hours to days, even frequently scheduled routine follow-up with a physician cannot effectively detect most developing exacerbations.

It is therefore desirable to have a method that allows the routine, frequent monitoring of patients so that an exacerbation can be recognized early in its course. With the patient and/or physician thus alerted of the need for medical intervention, a developing exacerbation can more easily and inexpensively be terminated early in its course.

SUMMARY

In one embodiment, a method is disclosed for assessing the fluid level in a patient's lungs. A first transition value is obtained for a respiration-dependent blood parameter from a first Cheyne-Stokes respiration cycle. A first tidal volume of the lungs value is obtained during the first respiration cycle. A first fluid index is calculated as a function of the first transition value and the first tidal volume of the lungs value.

In another embodiment, a method is disclosed for assessing fluid level in a patient's lungs. Measurements of transitions are accumulated in a respiration-dependent blood parameter during a first period of Cheyne-Stokes respiration. Measurements are accumulated of tidal volume of the lungs during the first period. A first fluid index is calculated as a function of the accumulated measurements of transitions and from the accumulated measurements of tidal volume during the first period. Measurements of transitions are accumulated in a respiration-dependent blood parameter during a second period of Cheyne-Stokes respiration. Measurements of tidal volume of the lungs are accumulated during the second period. A second fluid index is calculated as a function of the accumulated measurements of transitions and from the accumulated measurements of tidal volume during the second period. The first fluid index and the second fluid index are compared to obtain an indication of the fluid level in the patient's lungs.

An apparatus for assessing severity of lung fluid in a congestive heart failure patient is also described. The apparatus comprises a first sensor having an output related to blood gas levels in a patient. In addition, the apparatus comprises a second sensor having an output related to lung tidal volumes. The apparatus also comprises circuitry to determine a lung fluid index based on the blood gas levels and lung tidal volume.

Yet another embodiment is directed to a method of determining a fluid level in the lungs of a patient. The method comprises determining a blood gas level in the patient during a CSR cycle. In addition, the total tidal volume of the lungs of a patient during a CSR cycle is determined. The fluid level in the lungs based on the blood gas level and the lung tidal volume is assessed.

BRIEF DESCRIPTION OF THE DRAWINGS

FIG. 1A is a graph that models simulation of periodic breathing during Cheyne-Stokes respiration (CSR) showing a causal relationship between carbon dioxide and the respiratory pattern.

FIG. 1B is a graph that models simulation of periodic breathing during Cheyne-Stokes respiration (CSR) showing a causal relationship between oxygen saturation and the respiratory pattern.

FIG. 2A is a graph that illustrates the concentration change of carbon dioxide in the blood during clusters of breathing in Cheyne-Stokes respiration.

FIG. 2B is a graph showing respiratory tidal volumes representing Cheyne-Stokes respiration.

FIG. 3 is a graph that illustrates intrathoracic impedance during Cheyne-Stokes respiration.

FIG. 4 is a graph illustrating phrenic nerve activity during Cheyne-Stokes respiration.

FIG. 5A is a graph of the lung fluid index for a patient in good health and in poor health.

FIG. 5B is a graph of the lung fluid index over time for a patient in good health and in poor health.

FIG. 6 is a functional block diagram of a preferred monitor of the invention.

FIG. 7 is a flow chart of a method for determining lung fluid index.

FIG. 8 is a flow chart of another method for determining lung fluid index.

DETAILED DESCRIPTION

The invention relates to an apparatus and method to assess the fluid level in lungs. An implantable medical device or an external monitor is used to sense or monitor the patient's respiratory patterns to identify the presence of periodic breathing or Cheyne-Stokes Respiration (CSR). CSR is common in patients with congestive heart failure (CHF). This characteristic respiratory pattern is associated with lung-to-brain circulatory delay caused by the declining hemodynamic status of an acute heart failure exacerbation, and is thought to be an indirect result of developing pulmonary edema.

The role of gas exchange in the lungs is to remove carbon dioxide (CO₂) from blood and place oxygen (O₂) into the blood. The total removal rate of CO₂ or the total absorption rate of O₂ is dependent on the total functional alveolae exposed to the air. The removal rate or absorption rate can be used as a heart failure surrogate trend to assess the degree of severity of congestive heart failure based on lung fluid retention.

A fluid index can be used to assess the severity of congestive heart failure in a patient. During a respiration event, such as a CSR cycle **100** (a cluster of breaths from the onset of breathing to the end of apnea) in FIG. 2B, a value for a transition in a respiration-dependent blood parameter is obtained. During the respiration event, a value for the tidal volume of the lungs is also obtained. The fluid index preferably is calculated from the ratio of these two values. A ratio of Δ blood gas/Total tidal volume can be used to determine the lung fluid index. In this aspect, the value for the transition in a respiration-dependent blood parameter may be the difference or change in blood gas (Δ blood gas) determined from the difference between the maximum and minimum readings of the blood gas from a blood gas sensor surrogate, such as pH or saturated O₂. The lung tidal volume may be measured or estimated using, for instance, intrathoracic impedance, phrenic nerve activity or other techniques, such as a pneumotachometer or thermistor cannula positioned in the nose. The fluid index is preferably calculated for each respiration event, but may be calculated over many respiration events. CHF may be evaluated from the value of the lung fluid index or from changes in the lung fluid index over time.

FIG. 1A and FIG. 1B illustrate graph simulations of periodic breathing during Cheyne-Stokes respiration. FIG. 1A (Khoo, M. C. K, Understanding the Dynamics of State-Respiratory Interaction during Sleep, Bioengineering Approaches to Physiology and Medicine, Plenum Press, New York 1996) illustrates the causal relationship between arterial CO₂ concentration **107** and the respiratory patterns as a function of time during CSR. Periods of apnea **102** (absence of breathing) alternate with periods of hyperventilation **104**. During the apneic period **102**, blood O₂ saturation levels **106** fall (FIG. 1B) and blood CO₂ levels **107** increase (FIG. 1A). The increasing CO₂ levels result in a falling blood pH. During the periods of hyperventilation **104**, when the patient is rapidly breathing, the CO₂ level **107** decreases as blood oxygen saturation **106** increases. FIG. 1B (Khoo, M. C. K, Understanding the Dynamics of State-Respiratory Interaction during Sleep, Bioengineering Approaches to Physiology and Medicine, Plenum Press, New York 1996) illustrates the causal relationship between saturated O₂ concentration **106** and respiratory patterns as a function of time, during Cheyne-

Stokes respiration. Periods of apnea **102** alternate with periods of hyperventilation **104**. During the apneic period **102**, blood O₂ saturation **106** falls and blood CO₂ content **107** increases. During the periods of hyperventilation **104**, when the patient is rapidly breathing, the CO₂ content **107** decreases as blood oxygen saturation **106** increases. Thus, there is a wide swing of O₂, CO₂, saturated O₂, and pH levels during CSR. As can be seen from FIGS. 1A and 1B, when the CO₂ level is high, the saturated O₂ level is low, with a phase shift of about 90 degrees. Since saturated O₂ has the same swing as CO₂ during apnea (taking into account the phase shift), it is possible to correlate the breathing pattern to the CO₂ pattern or saturated O₂ pattern. If a CO₂ waveform is not available, such as in FIG. 1A, a saturated O₂ waveform, such as in FIG. 1B, can be used.

Referring to FIGS. 2A and 2B, during monitoring for CSR, such as daily monitoring, the implantable medical device, or other monitor, acquires maximum **108** and minimum **110** readings of a blood gas, such as carbon dioxide (CO₂) or oxygen (O₂), from a blood gas surrogate such as a pH sensor or a saturated O₂ sensor, over a selected period of time. FIG. 2A illustrates monitoring of CO₂ levels over three CSR cycles. During this selected period of time, sampling times of the blood gas are adjusted automatically by monitoring the respiration pattern, such as the onset of apnea **109** to the end **111** of the next onset of apnea. From the maximum **108** and minimum **110** readings, the difference (Δ blood gas) can be calculated. The sampling frequency can vary, such as four (4) samples per second. This data acquisition sampling may occur approximately every five (5) minutes for a 30 to 40 minute time period, usually once daily. Alternatively, a given number of respiration events (CSR cycles) may be sampled. The readings may be taken more or less frequently, as determined by the health care professional. Preferably, the maximum **108** and minimum **110** values may be separately accumulated or determined from each CSR cycle and each separate difference between the maximum and minimum values is used as Δ CO₂ when calculating the fluid index after each respiration event/CSR cycle. The plurality of fluid indices is then averaged.

Blood gas sampling may be used for CO₂ sensing. A blood gas surrogate for CO₂ is pH. The acidity of the blood stream can be interpolated to the CO₂ level by one skilled in the art since the pH level is generally the inverse of CO₂. The pH sensor can be positioned, for example, on a lead connected to the implantable medical device. Since the tissue is in equilibrium with the blood, the changes in chemical concentrations and pH that occur in the blood stream will be detected at the interface between the monitor housing and the tissue.

The sensor may also be an oxygen sensor which measures the oxygen saturation level in blood and subcutaneous tissue as well as the carbon dioxide level of the blood and tissue. The oxygen sensor may be positioned, for instance, on a lead that is electrically coupled to an implantable medical device, may be external, measuring the gas concentration upon exhalation, or may be percutaneous, for instance, within an abdominal patch. The leads may be implanted with the distal end situated in either the right atrium or right ventricle of the heart. In some embodiments, the oxygen sensor may be a combined O₂ saturation and vascular plethysmography sensor, in which the light source, preferably parallel and oppositely oriented red and infrared LEDs, are positioned such that light is directed into overlying tissue, and the light detector, preferably a photodiode, is positioned such that it collects light reflected by the overlying tissue, as discussed in U.S. Pat. No. 6,600,949, issued to Turcott, incorporated herein in its entirety.

Corresponding intrathoracic impedance or phrenic nerve activity sensing is used to estimate or measure the respiratory or lung tidal volume. In other alternative aspects, respiration is sensed using a pressure transducer placed within the pleural cavity and connected to the implantable hemodynamic monitor. Such a transducer can be placed extravascularly within the thoracic cavity, intravascularly within the venous system, or in an intracardiac position. In the latter embodiment, changes in intrathoracic pressure associated with respiration are readily detected, particularly during diastole.

Volume or pressure variations within the right ventricle or right atrium attributable to respiratory activities are sensed through intrathoracic impedance. In general, impedance mainly measures the air in the lungs. The more air present in the lungs, the higher the impedance. An intrathoracic impedance measurement is preferably obtained between an electrode (for example, a stimulation electrode, if the implanted device is a pacemaker) and the case of the implantable medical device, or alternatively, between two electrodes laid out in a rib cage. The impedance is measured by injection of a constant current of a few hundred milliamperes, at a frequency of a few Hertz, typically less than 60 Hertz.

As shown in FIG. 2B, the tidal volume of a cluster of breaths V_1, V_2, V_3, V_4 during a selected breathing period of one CSR cycle **100** is estimated or measured using intrathoracic impedance. Corresponding intrathoracic impedance peak-to-peak is used as the peak value for each breath to estimate the respiratory or lung tidal volume, as shown in the graph in FIG. 3. The selected breathing period during which the tidal volumes are measured may be for about one minute approximately every five (5) minutes for a 30 to 40 minute period, usually once daily. However, the values may be taken more or less frequently, as determined by the health care professional. The selected breathing period generally corresponds to the time period during which the maximum and minimum values for the blood gas are obtained for one CSR cycle. In FIG. 2B, each peak $V_1, V_2, V_3, V_4, V_5, V_6, V_7, V_8$ corresponds to a breath taken after a long apneic period, which causes a slow fall in CO_2 concentration. The tidal volume of each breath generally can vary, as shown in FIGS. 1A, 1B, 2B, and 3, although some of the breaths may be of the same or similar tidal volume. Preferably, the tidal volumes of the lungs may be separately accumulated or determined for each respiration event/CSR cycle (cluster of breaths such as peaks V_1, V_2, V_3, V_4), and the separate values may be summed for each CSR cycle to estimate total tidal volume ΣV_i when calculating the fluid index for each CSR cycle. The plurality of fluid indices is then averaged.

Referring to FIGS. 1A, 1B, 2A and 2B, as the CO_2 concentration **107** in the blood increases toward maximum **108** of CO_2 following an apneic period **102**, hyperventilation **104** begins, increasing the blood oxygen saturation level **106** as the patient begins to rapidly breathe. As hyperventilation **104** and inhalation continues, the tidal volumes of each breath $V_1, V_2, V_3, V_4, V_5, V_6, V_7, V_8$ can vary, such that each CSR cycle has a wax and wane pattern, or modulates. As the blood oxygen saturation level is reached, the CO_2 concentration decreases towards CO_2 minimum **110**. When the breathing becomes shallower, such as before V_4 in FIG. 2B, another apneic period **102** begins, and the CO_2 concentration level begins to increase. As can be seen in FIGS. 1A, 1B, 2A, and 2B, there may be a small lag period between the beginning of apnea and when the CO_2 concentrations begin to rise, and between hyperventilation and when oxygen saturation occurs. This lag period will vary from individual to individual. It may be necessary to obtain more data points to

obtain the correct maximum-minimum value (ΔCO_2) corresponding to the matched CSR cycle.

As an alternative to intrathoracic impedance, another surrogate for lung volume is phrenic nerve sensing. The phrenic nerve is connected to the lung diaphragm. Thus, sensing of phrenic nerve activity as each breath is taken can also provide an estimate of lung tidal volume. A lead connected to an implantable medical device may have a sensor attached to the lead, such that the sensor is adjacent the phrenic nerve. The sensor may be used to sense activity or movement of the phrenic nerve. As the diaphragm expands upon inhalation, the phrenic nerve stimulates the lead, such that the sensor provides an estimate of the lung tidal volume.

Referring to FIG. 4, as each breath is taken, as at **120**, signals **122** are generated, indicating phrenic nerve activity. The signals are averaged over a selected period of time, such as for about one minute approximately every five (5) minutes during a 30 to 40 minute time period, usually once daily. Alternatively, a given number of inhalations may be used. The readings may be taken more or less frequently, as determined by the health care professional. Each respiratory effort produces a phrenic nerve value **124**. The calculated area **126** under the substantially triangular shape **127** of phrenic nerve value **124** provides an estimate of the lung tidal volume, similar to V_1, V_2, V_3 and V_4 in FIG. 2B. Shape **127** may be shapes other than triangular, such as rectangular or semi-circular, with the area under the shape being calculated to determine the tidal volume. Shape **127** is generally determined based on the patient.

To determine whether to integrate the phrenic nerve activity, a desired noise threshold is selected so as to discriminate for the desired phrenic nerve activity. If the phrenic nerve activity is over that certain threshold **129**, the signal is integrated. Preferably, the calculated area of **124** may be separately accumulated or determined for each respiration event/CSR cycle, or the separate maximum height values **128** may be used to estimate total tidal volume ΣV_i when calculating the fluid index for each CSR cycle. The plurality of fluid indices is then averaged.

An external device, such as a pneumotachometer, can also be used to calibrate an implanted impedance sensor to estimate, measure or calibrate the lung tidal volume. The external pneumotachometer can send flow signals by wireless telemetry to the implanted device to correspond to the tidal volume. In addition, a thermistor cannula can measure the air flow exhaled over time to estimate or calibrate the tidal volume.

A lung fluid index reflecting the total lung volume required to remove a blood gas, such as CO_2 , may be calculated using the following ratio:

$$\text{Fluid index} = \frac{\Delta CO_2}{\sum_{i=1}^N V_i}$$

where ΔCO_2 is the difference between the maximum and minimum readings of the blood gas, such as CO_2 , ΣV_i is the summation of the lung tidal volumes determined, for instance, from intrathoracic impedance or phrenic nerve activity values, and i is from one breath to a number of breaths N during each CSR cycle. A lung fluid index for O_2 surrogates, such as saturated O_2 , can also be calculated using the fluid index ratio above.

One purpose of the respiratory organ (lungs) is to remove CO_2 from the body and to add O_2 to the body. When a patient is in good health, there is less fluid in the lungs. Thus, there is

more area in the lungs for gas exchange. If the assumption is that ΔCO_2 (swing from maximum to minimum) remains fixed, the healthy patient may only have to breathe a few breaths to remove the CO_2 . Therefore, the summed total respiration or tidal volume (ΣV_T) to remove a given amount of ΔCO_2 within a CSR cycle in a healthy patient will be less, as shown by the ratio or fluid index, or slope **130**, in FIG. 5A. However, as the lungs become more congested in patients with CHF due to fluidic edema, it will take many more breaths to remove the CO_2 as compared to a healthier individual due to compromised gas exchange efficiency. Therefore, the summed total tidal volume (ΣV_T) must increase to remove the same amount of ΔCO_2 , as shown by the slope at **131**. A decreased gas exchange area due to increased fluid in the lungs causes the need for increased total tidal volume. Therefore, the lung fluid index in a diseased patient tends to be less. The lung fluid index decreases as the patient's CHF condition deteriorates. The more congestion, the larger the tidal volume will need to be to remove the same amount of ΔCO_2 , which will be reflected in the ratio.

This ratio is stored and used as a lung fluid index to assess the severity of fluid in the lungs. Referring to FIG. 5B, as long as the ratio remains over a certain threshold **132**, the patient does not have to worry about the build up of fluid in the lungs. However, as the ratio decreases over time, the severity of the fluid in the lungs will need to be closely monitored. Long term threshold value **132** is determined over the long term and the short term threshold value **133** is determined over the short term. The short term average of threshold value **133** and long term average of threshold value **132** may be calculated each day. The difference D between the short term average and long term average threshold values may be determined by subtracting the short term average from the long term average ($D = \text{Long}_{av} - \text{Short}_{av}$). The long term average threshold value may be determined by averaging the threshold values for approximately the preceding thirty (30) days. The short term average threshold value may be determined by averaging the threshold values for approximately the preceding three (3) days. To prevent the long term average threshold value from becoming too low, a minimum limit may be imposed. A minimum limit is chosen as a fixed value so that it does not decrease as heart failure worsens. If the thirty (30) day long term average is lower than this minimum limit, this minimum limit is used as the long term threshold value. The trend in the patient's health condition can be monitored using these values. As D increases, the implanted medical device will be interrogated, and an alarm will be generated or go off, thereby alerting the physician and patient as to the worsening condition. Monitoring the fluid levels in the lungs, such as daily, will alert the patient and the physician as to any trends toward worsening pulmonary edema so that corrective action can be taken before the fluid level gets to a level requiring hospitalization of the patient.

The Cheyne-Stokes respiratory pattern can thus be detected by methods that measure metabolic gases and chemicals and recognize the oscillatory changes that occur over time scales consistent with the Cheyne-Stokes respiratory pattern, or methods that directly assess the mechanical changes in the thorax associated with breathing. This invention takes advantage of swing patterns of a blood gas, such as CO_2 , during the Cheyne-Stokes respiratory pattern.

Many implantable medical devices provide data acquisition of physiological information from a human body. The implantable medical device can be housed within a hermetically sealed canister or housing, which may itself be conductive so as to serve as an electrode in the implantable medical device. One or more sensors/leads are electrically coupled to

the implantable medical device and extended into the right atrium or right ventricle of the patient's heart. The implantable medical device may be, for example, cardiac systems including implantable heart monitors and therapy delivery devices, such as pacemakers, cardioverters, defibrillators (ICD), heart pumps, card iomyostimulators, ischemia treatment devices, and other heart therapy devices. The implantable medical device can also be a sleep apnea detection device, such as an intrathoracic impedance monitor or accelerometer mounted on or near the chest, or can be a dedicated fluid monitor. External devices have been discussed above (pneumotachometer and thermistor cannula).

A functional block diagram of an implantable medical device or monitor that can be used in the invention is shown in FIG. 6. One or a plurality of sensors **134a**, **134b**, . . . **134n** is connected to an electronic circuit **135**, which may be connected to a patient alert **137**, transmitter/receiver **136**, and memory **138**, with each of elements **137**, **136** and **138** being optional. In a preferred embodiment, the electronic circuit **135** includes a low-power microprocessor. In alternate embodiments, the microprocessor is excluded, or control and higher level processing is performed by a microcontroller, an embedded system, a programmable logic device such as a field-programmable logic array, or a combinatorial implementation of a state machine.

In FIG. 7, a flow chart illustrating the process used to determine the lung fluid index reflecting total lung volume required to remove CO_2 from blood gas is shown. The electronic circuit need not necessarily acquire and process data continuously. Preferably, the electronic circuit contains a timer that periodically initiates data acquisition. In one aspect, one of the sensors is an accelerometer. The output of the accelerometer is used by the electronic circuit to condition data acquisition on the activity of the patient. In block **150**, the activity level of the patient is determined. If the patient is awake, the algorithm waits. Data can be scheduled to be acquired and processed at a selected time interval, such as every night. If the patient is asleep, data is acquired at the scheduled time. If the activity of patient is not below a certain threshold, such as the patient is not asleep, the algorithm waits until the condition is met. If the activity of the patient is below the desired threshold, in block **152**, a patient is checked to see if they have been asleep for a predetermined time interval and if there is CSR. The predetermined time period in block **152** can vary, such as for one half hour, or can be determined by the phase of sleep the patient is in. If the patient is not asleep or if CSR has not started, then data is acquired the next time the condition is satisfied. If the monitor detects that CSR has started at block **154**, the maximum and minimum values of the selected blood gas are detected at block **156**. For instance, if CO_2 is the selected blood gas, the monitor determines whether CO_2 is at a maximum at block **158**. If the CO_2 is not at a maximum, then data is acquired the next time the condition is satisfied. If CO_2 is at a maximum, then the intrathoracic amplitude is detected at block **160**. The surrogates of respiration or tidal volume, such as intrathoracic amplitude (impedance), is measured and summed until CO_2 is at a minimum at block **162**. If the CO_2 is not at a minimum, the intrathoracic amplitudes continue to be measured until CO_2 is at a minimum value. Once the CO_2 minimum is determined, ΔCO_2 (delta CO_2) is calculated at block **164** by subtracting the CO_2 at its minimum value from CO_2 at its maximum value. The tidal volumes are summed together at block **166**. The lung fluid index or slope, which is the ratio of ΔCO_2 over the sum of the tidal volumes, is determined at block **168**. Alternatively, at block **160**, phrenic nerve activity can be sensed rather than intrathoracic amplitudes, as discussed above. The

tidal volumes estimated by the area under the shape of the phrenic nerve values or the separate maximum height values are summed at block 166.

The flow chart in FIG. 7 can be used to track the patient condition after each respiration event/CSR cycle, or can average the fluid index over multiple events to obtain a filtered number for purposes of monitoring patients.

In FIG. 8, a flow chart illustrating another process used to determine the lung fluid index reflecting total lung volume required to remove a blood gas for a selected period of time is shown. The electronic circuit need not necessarily acquire and process data continuously. Preferably, the electronic circuit contains a timer that periodically initiates data acquisition. In one aspect, one of the sensors is an accelerometer. The output of the accelerometer is used by the electronic circuit to condition data acquisition on the activity of the patient. In block 170, the activity level of the patient is determined. If the patient is awake, the algorithm waits. Data can be scheduled to be acquired and processed at a selected time interval, such as every night. If the activity of patient is not below a certain threshold, such as the patient is not asleep, the algorithm waits until the condition is met. If the activity of the patient is below the desired threshold, such as if the patient is asleep, data is acquired at the scheduled time. If the patient is not asleep, the algorithm waits until the condition is met. In block 172, a patient is checked to see if they have been asleep for a predetermined time interval and if there is CSR. The predetermined time period in block 172 can vary, such as for one half hour, or can be determined by the phase of sleep the patient is in. If the patient is not asleep or if CSR has not started, then data is acquired the next time the condition is satisfied. If the monitor detects that CSR has started at block 174, the maximum and minimum values of the selected blood gas are measured for a selected period of time, and the difference between the maximum and minimum values are determined at block 176. For instance, if CO₂ is the selected blood gas, the monitor determines the CO₂ maximum and CO₂ minimum over the time period, and ΔCO₂ is calculated by summing all of the calculated differences of the CO₂ minimum values from the CO₂ maximum value over the time period. The ΔCO₂ are summed at block 178. The tidal volumes are detected at block 180. Tidal volumes are summed together at block 182. At block 184, a determination is made whether the selected time period has ended. If it has not, then data is acquired the next time the condition is satisfied. If the selected time period has ended, the lung fluid index or slope, which is the ratio of the sum of ΔCO₂ over the sum of the tidal volumes, is determined at block 186. Alternatively, at block 180, phrenic nerve activity can be sensed rather than intrathoracic amplitudes, as discussed above. The tidal volumes estimated by the area under the shape of the phrenic nerve values or the separate maximum height values are summed at block 182. The flow chart in FIG. 8 can average the fluid index over multiple events over a period of time to obtain a filtered number for purposes of monitoring patients.

The description of the invention including its applications and advantages as set forth herein is illustrative and is not intended to limit the scope of the invention, which is set forth in the claims. Variations and modifications of the embodiments disclosed herein are possible, and practical alternatives to and equivalents of the various elements of the embodiments would be understood to those of ordinary skill in the art upon study of this patent document. Other techniques may be used to determine the change in blood gas concentration (ΔCO₂) or estimate the tidal volume. These and other varia-

tions and modifications of the embodiments disclosed herein may be made without departing from the scope and spirit of the invention.

Although the present invention has been described with reference to preferred embodiments, workers skilled in the art will recognize that changes may be made in form and detail without departing from the spirit and scope of the invention.

What is claimed is:

1. A method for use by an implantable medical device for assessing fluid level in a patient's lungs, comprising:
 - detecting a first Cheyne-Stokes respiration cycle;
 - obtaining a first transition value for a respiration-dependent blood parameter during the first Cheyne-Stokes respiration cycle, wherein the first transition value is representative of a change in blood gas levels within the patient during the first Cheyne-Stokes respiration cycle;
 - obtaining a first tidal volume of the lungs value during the corresponding first Cheyne-Stokes respiration cycle;
 - deriving a first fluid index for the first Cheyne-Stokes respiration cycle from the first transition value and the first tidal volume of the lungs value; and
 assessing fluid level in the lungs of the patient during Cheyne-Stokes respiration based on the first fluid index.
2. The method of claim 1 wherein:
 - obtaining the first transition value comprises detecting a minimum value and a maximum value of CO₂ concentration and determining the change in blood gas levels within the patient from the minimum and maximum values of CO₂ concentration.
3. The method of claim 1 wherein:
 - obtaining the first tidal volume of the lungs value comprises integrating phrenic nerve activity.
4. The method of claim 1 wherein:
 - obtaining the first tidal volume of the lungs value comprises calibrating an impedance sensor from a pneumotachometer.
5. The method of claim 1 wherein:
 - obtaining the first tidal volume of the lungs value comprises calibrating air flow from a thermistor cannula.
6. The method of claim 1 wherein:
 - obtaining the first transition value comprises detecting a minimum value and a maximum value of O₂ concentration and determining the change in blood gas levels within the patient from the minimum and maximum values of O₂ concentration.
7. The method of claim 1 further comprising:
 - detecting a second Cheyne-Stokes respiration cycle;
 - obtaining a second transition value of a respiration-dependent blood parameter, the second transition value occurring during the second Cheyne-Stokes respiration cycle;
 - obtaining a second tidal volume of the lungs value during the second Cheyne-Stokes respiration cycle;
 - deriving a second fluid index for the second Cheyne-Stokes respiration cycle from the second transition value and the second tidal volume of the lungs value; and
 - comparing the first fluid index and the second fluid index to obtain a further indication of the fluid level in the patient's lungs.
8. The method of claim 1 wherein obtaining the first tidal volume of the lungs value comprises summing intrathoracic impedance.
9. A method for assessing fluid level in a patient's lungs for use by an implantable medical device, comprising:
 - detecting first and second periods of Cheyne-Stokes respiration;
 - accumulating measurements of transitions in a respiration-dependent blood parameter during the first period of

11

Cheyne-Stokes respiration, wherein the respiration-dependent blood parameter is representative of changes in blood gas levels within the patient during the first period of Cheyne-Stokes respiration;

accumulating measurements of tidal volume of the lungs 5 during the first period of Cheyne-Stokes respiration;

deriving a first fluid index for the first period of Cheyne-Stokes respiration as a function of the accumulated measurements of transitions and from the accumulated measurements of tidal volume during the first period of 10 Cheyne-Stokes respiration;

accumulating measurements of transitions in the respiration-dependent blood parameter during the second period of Cheyne-Stokes respiration;

accumulating measurements of tidal volume of the lungs 15 during the second period of Cheyne-Stokes respiration;

deriving a second fluid index from the accumulated measurements of transitions in the respiration-dependent blood parameter and from the accumulated measurements of tidal volume during the second period of 20 Cheyne-Stokes respiration; and

assessing a fluid level in the lungs by comparing the first fluid index and the second fluid index.

10. A method of determining a fluid level in the lungs of a patient for use by an implantable medical device, comprising:

12

detecting a Cheyne-Stokes respiration (CSR) cycle;

determining a blood gas level in the patient during the CSR cycle;

determining a total tidal volume of the lungs of a patient during the CSR cycle;

deriving a fluid index for the CSR cycle based on the blood gas level and the total tidal volume of the lungs; and

assessing a fluid level in the lungs of the patient based on the fluid index.

11. The method of claim **10** wherein the determining of the blood gas level comprises measuring a change in blood gas levels.

12. The method of claim **10** wherein the total tidal volume is determined using intrathoracic impedance.

13. The method of claim **10** wherein deriving a fluid index includes determining a ratio of a change in blood gas level to a tidal volume.

14. The method of claim **13** further including detecting an indication of the health of the patient by comparing the ratio against a predetermined threshold indicative of poor health.

15. The method of claim **14** further including alerting the patient if the ratio falls below the predetermined threshold indicative of poor health.

* * * * *

专利名称(译)	用于评估肺中液位的方法和装置		
公开(公告)号	US7704211	公开(公告)日	2010-04-27
申请号	US11/086612	申请日	2005-03-21
[标]申请(专利权)人(译)	标兵		
申请(专利权)人(译)	PACESETTER , INC.		
当前申请(专利权)人(译)	PACESETTER , INC.		
[标]发明人	KOH STEVE		
发明人	KOH, STEVE		
IPC分类号	A61B5/02 A61B5/00 A61B5/08		
CPC分类号	A61B5/0809 A61B5/4818 A61B5/145 A61B5/04001 A61B5/091 A61B5/14551 A61B5/686 A61F13/4704 A61F13/47236 A61F13/535		
外部链接	Espacenet USPTO		

摘要(译)

本发明涉及评估肺部液位的装置和方法。植入式医疗设备或外部监视器用于感测或监测患者的呼吸模式，以识别周期性呼吸或Cheyne-Stokes呼吸 (CSR) 的存在，这在患有充血性心力衰竭的患者中是常见的。流体指数用于评估患者充血性心力衰竭的严重程度。 Δ 血气/ Σ 总肺容积的比率可用于确定肺液指数。

