



(19) **United States**

(12) **Patent Application Publication**
Gugliotti et al.

(10) **Pub. No.: US 2008/0242945 A1**

(43) **Pub. Date: Oct. 2, 2008**

(54) **FACILITY MANAGEMENT SYSTEM**

Publication Classification

(75) **Inventors:** Nicola Gugliotti, Watertown, CT (US); Harold Todd Tyler, Lincoln, NE (US)

(51) **Int. Cl.**
A61B 5/00 (2006.01)

(52) **U.S. Cl.** 600/300

(57) **ABSTRACT**

Correspondence Address:
PILLSBURY WINTHROP SHAW PITTMAN, LLP
P.O. BOX 10500
MCLEAN, VA 22102 (US)

The invention provides systems and methods for acquiring, manipulating, and monitoring data associated with one or more assisted living facilities. The invention includes utilizing one or more monitoring devices to gather data regarding at least one assisted living facility. The data is then transmitted across a network and saved in a database. An enterprise management application then operates on the data to manipulate and display the data according to parameters and instructions specified by one or more users. The data may be used by the one or more users to monitor and manage the one or more assisted living facilities.

(73) **Assignee:** Stanley Security Solutions, Inc., Indianapolis, IN (US)

(21) **Appl. No.:** 11/729,848

(22) **Filed:** Mar. 30, 2007

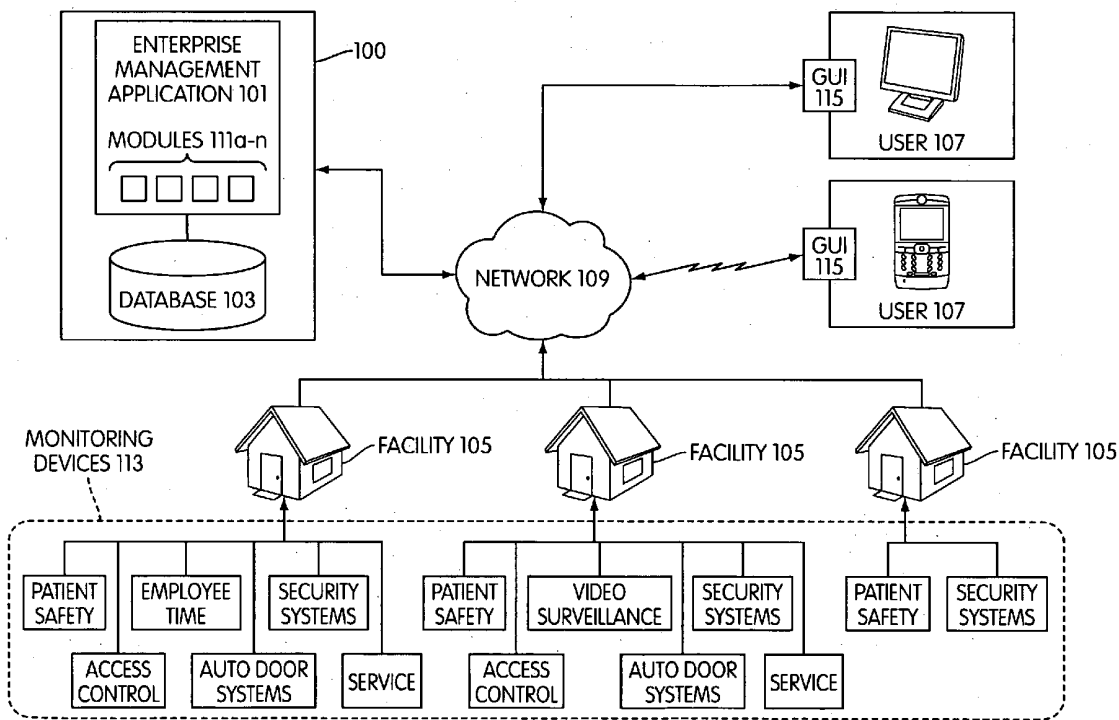

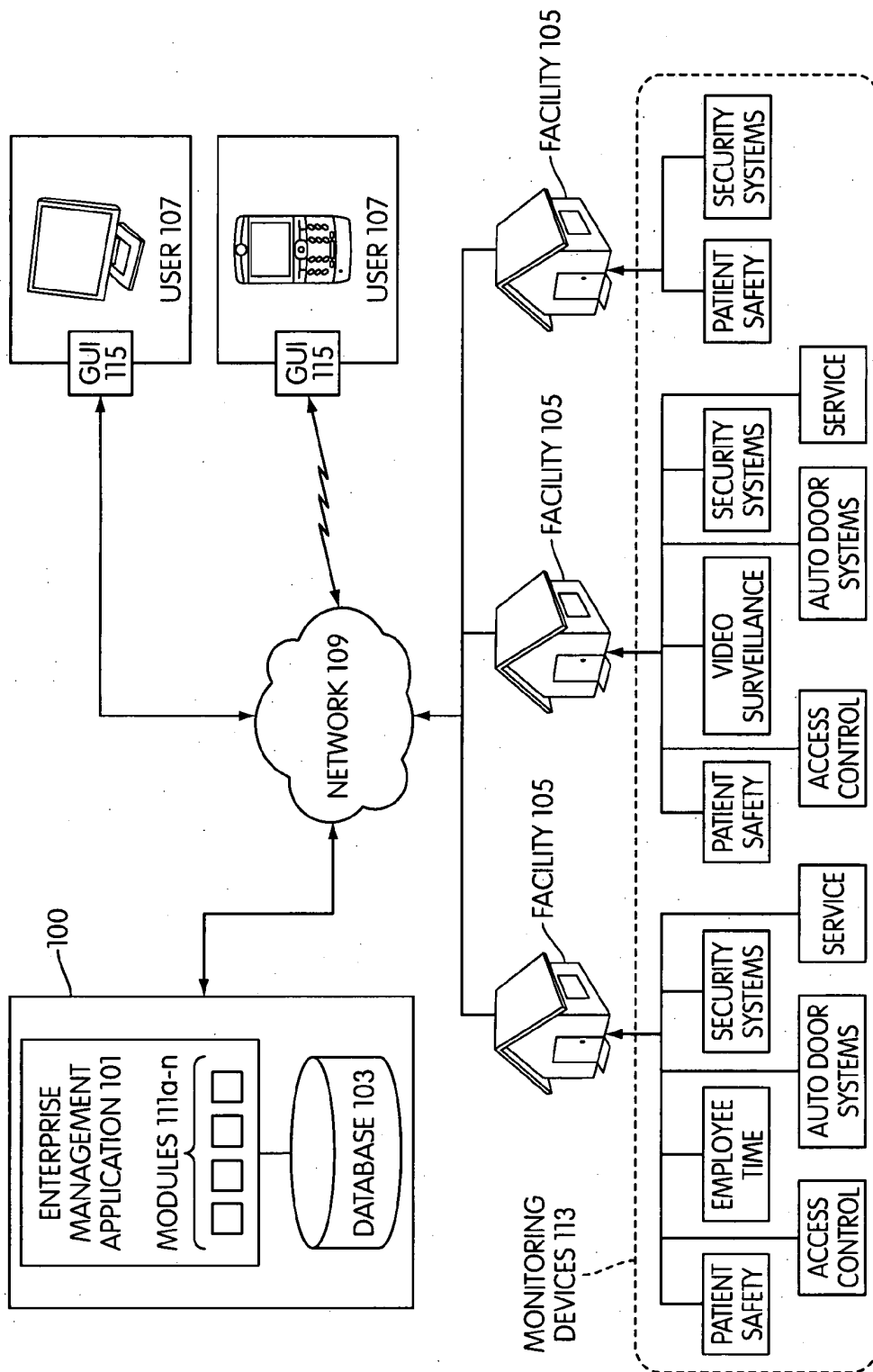

FIG. 1A

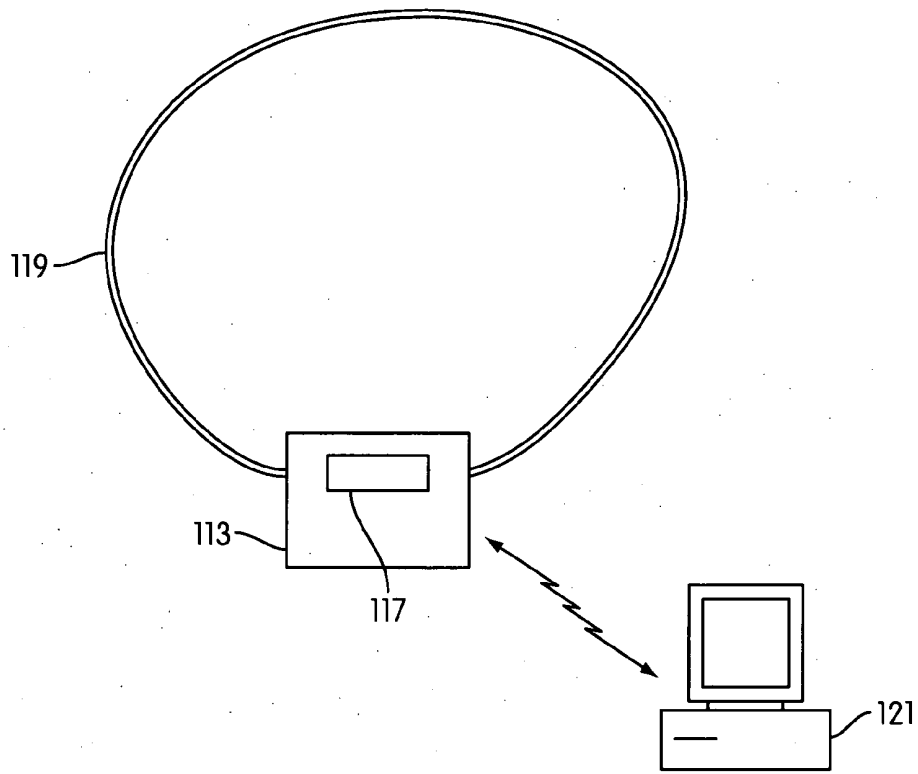

FIG. 1B

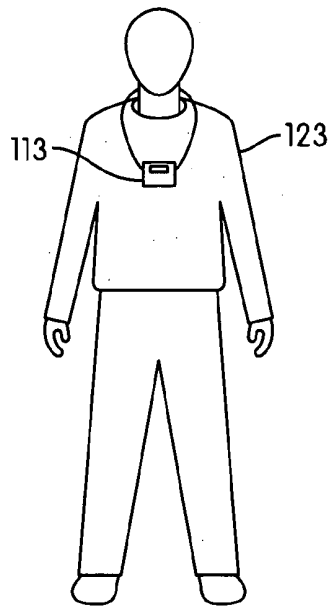

FIG. 1C

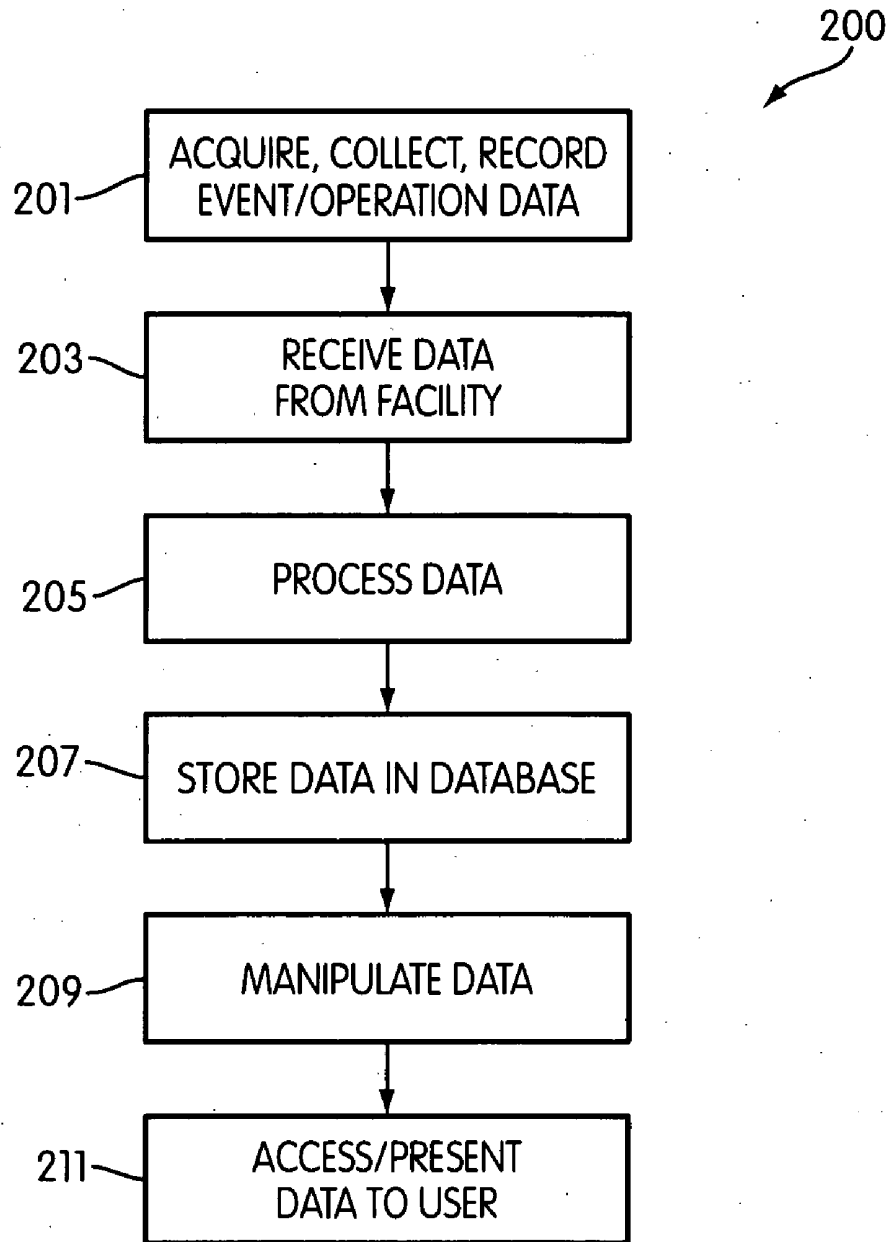
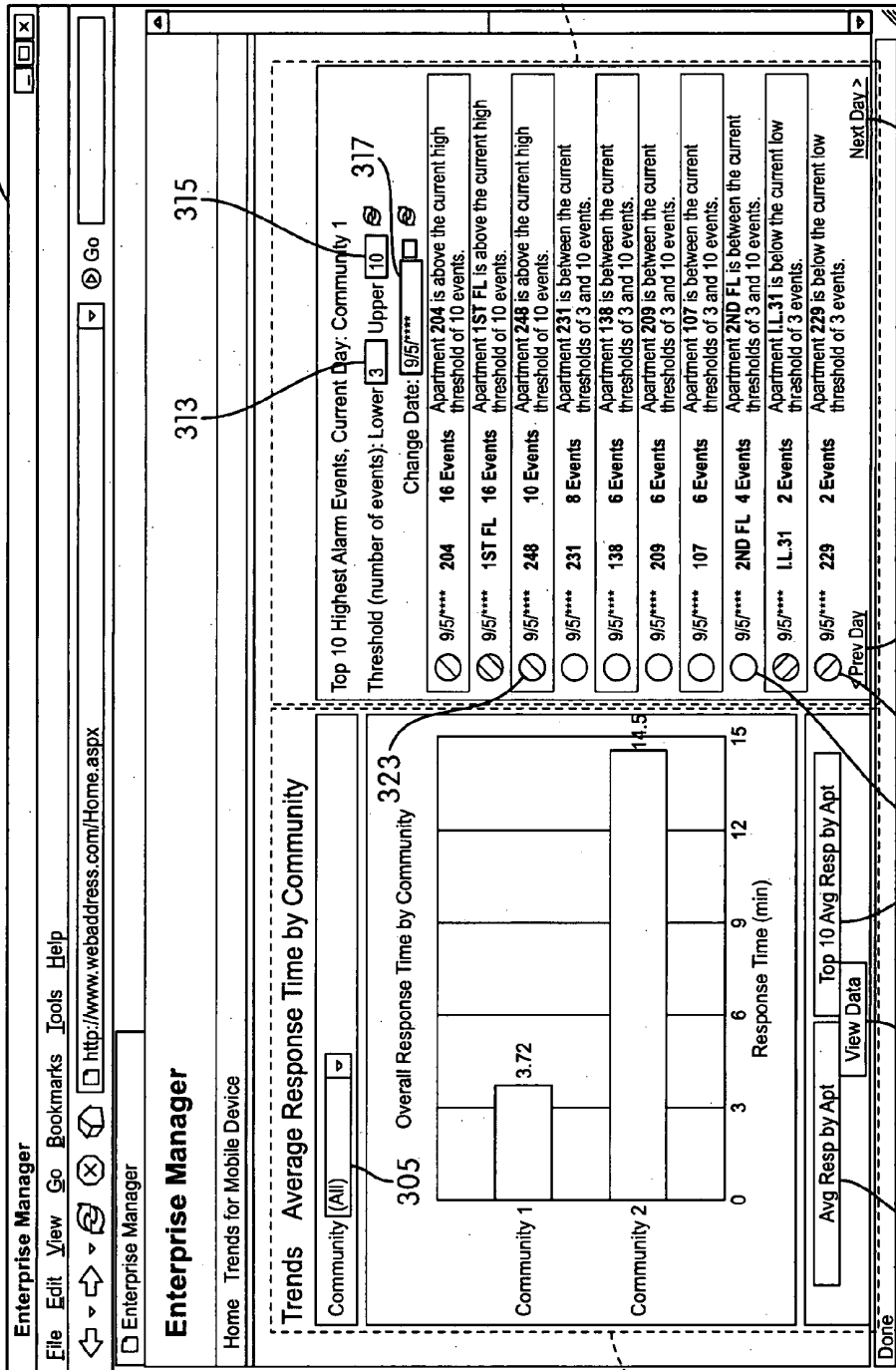

FIG. 2

300



303

313

315

317

323

325

327

329

331

333

301

FIG. 3

400

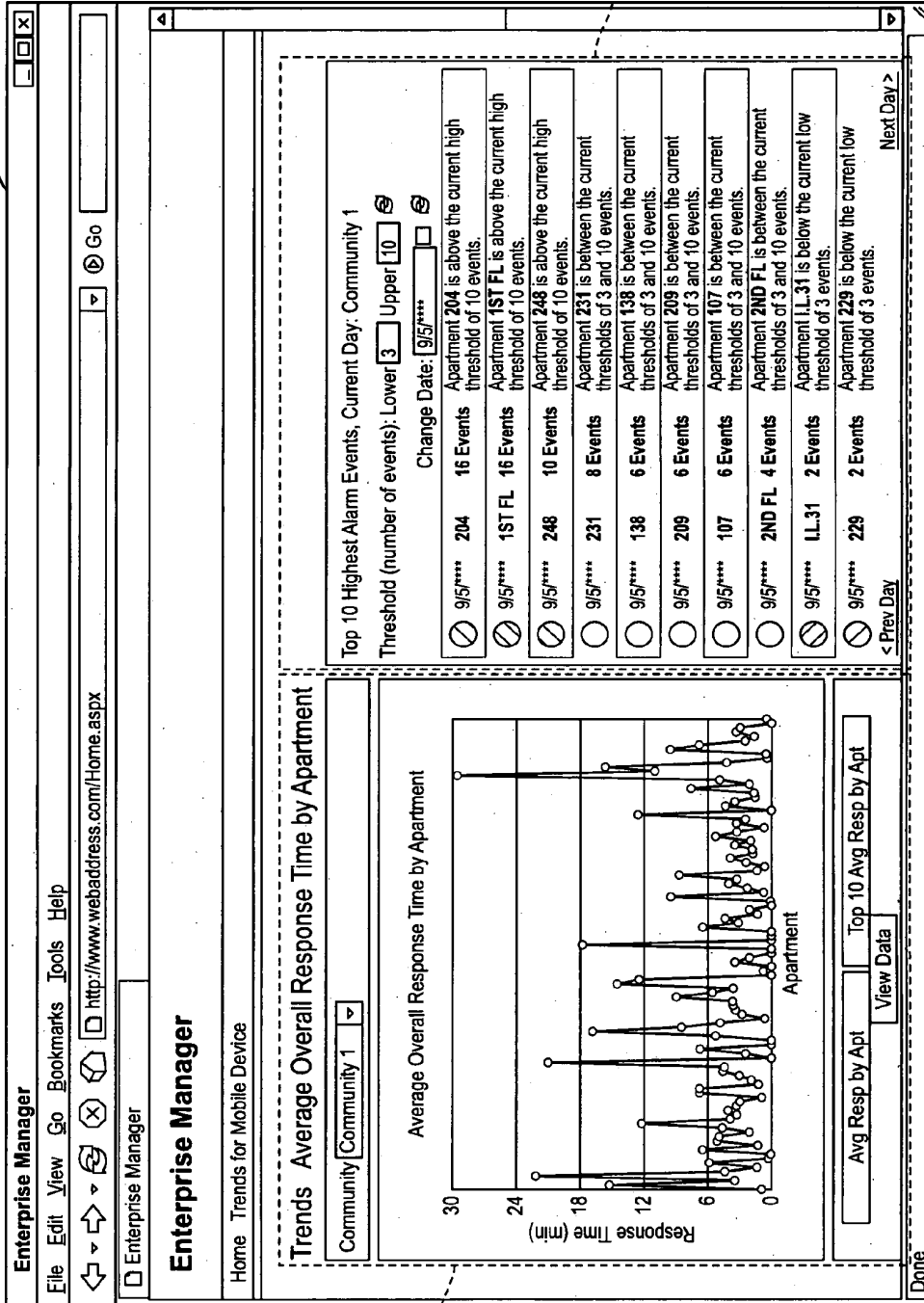

401

403

FIG. 4

500

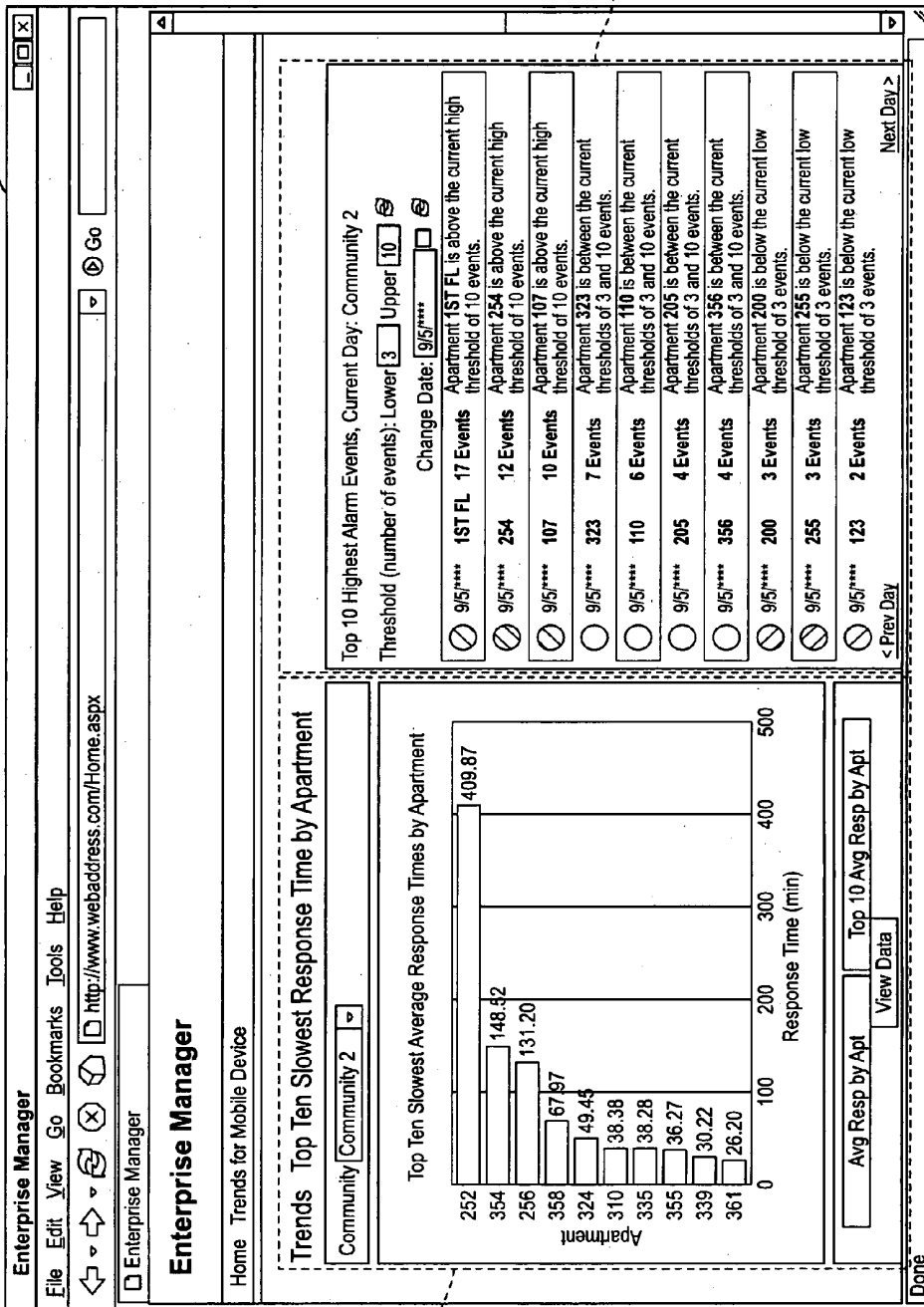

501

503

FIG. 5

600

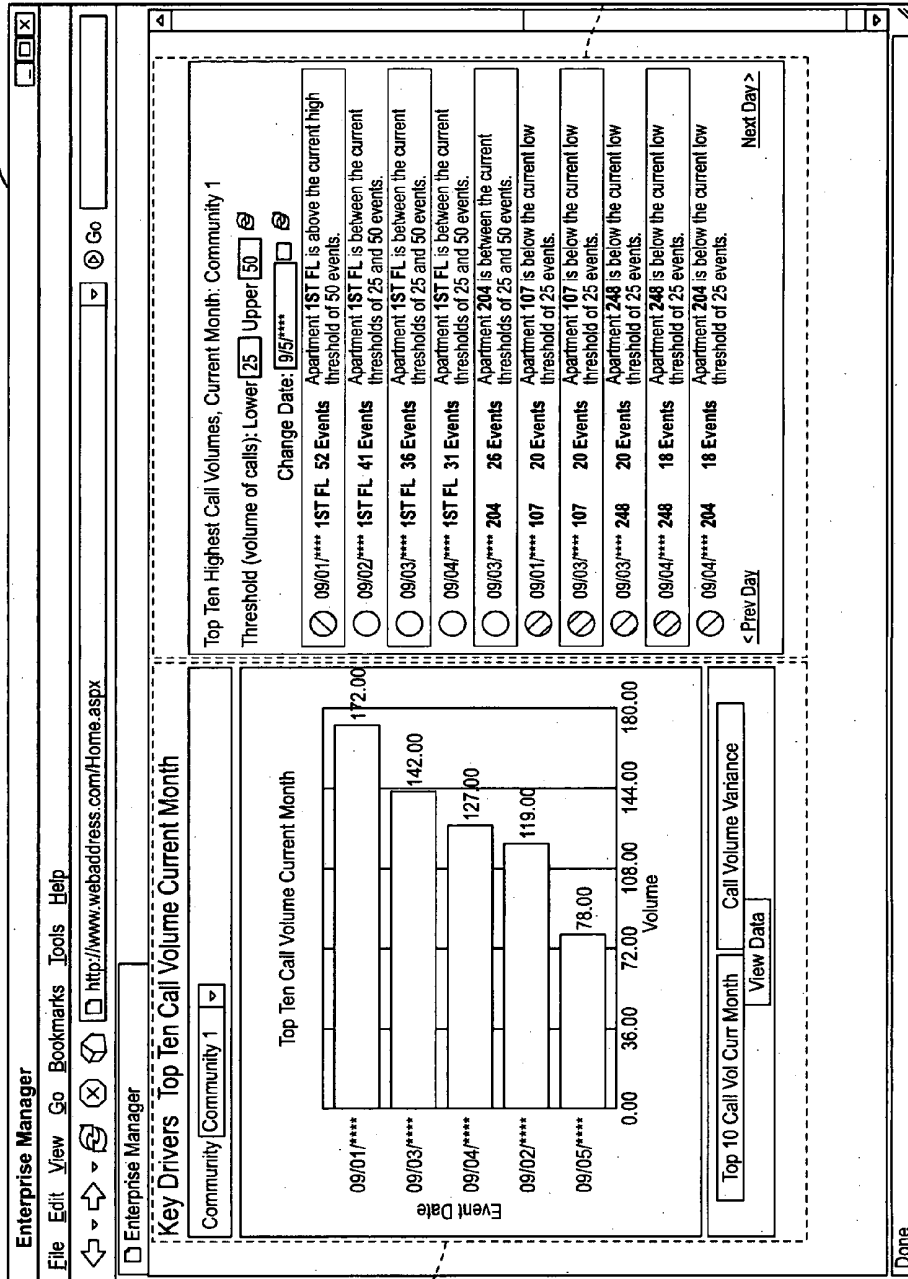

601

603

FIG. 6

700

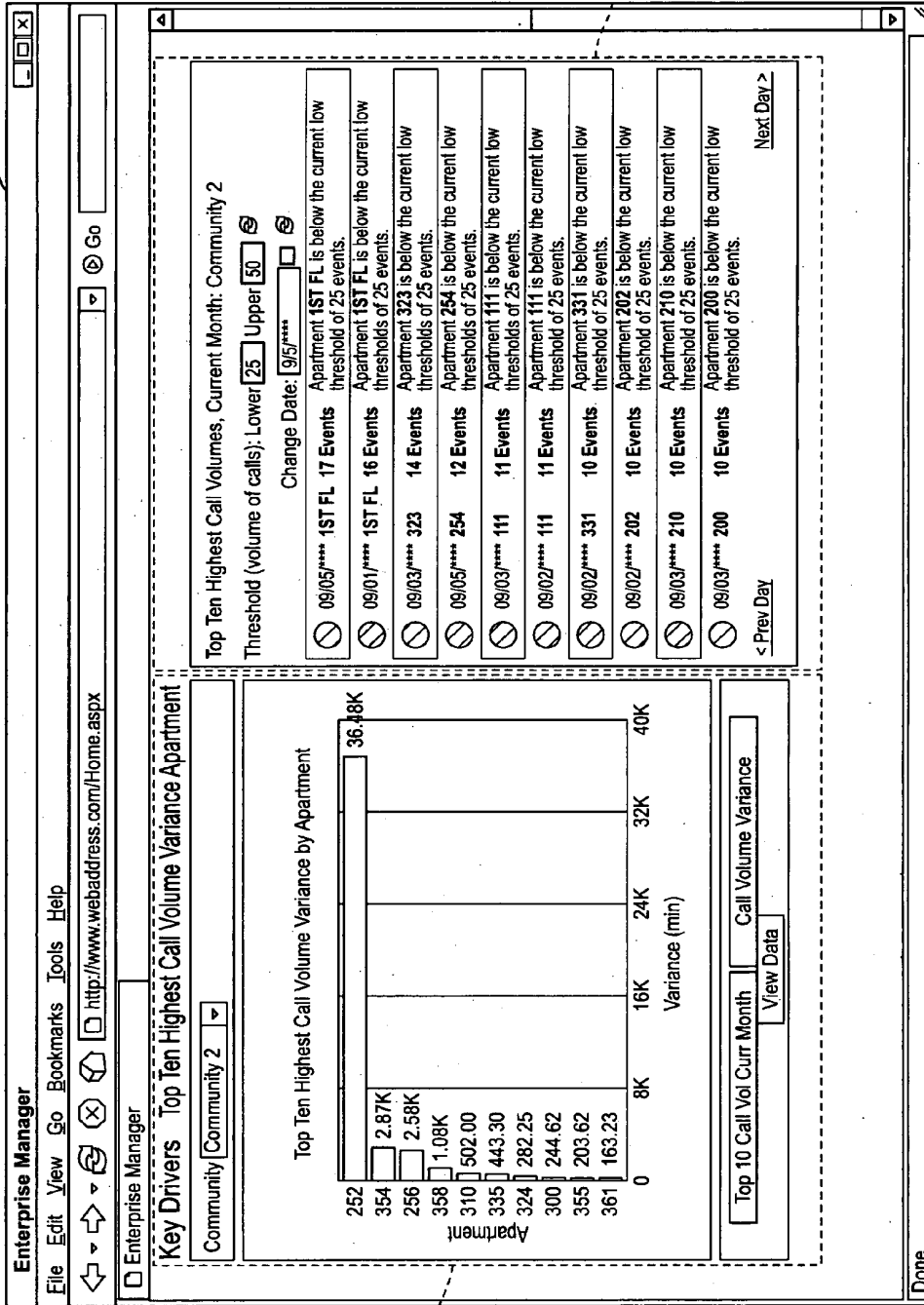

701

703

FIG. 7

800

Response Times: Community 1

File Edit View Go Bookmarks Tools Help

Go http://www.webaddress.com/Home.aspx

Enterprise Manager

Enterprise Manager Detailed Data View with Filtering Capabilities

Home Trends for Mobile Device

Response Times: Community 1

Community [Community 1] Apartment [(All)] Alarm Type [(All)] Date

805 807 809

Date	Apartment	Alarm Type	Response Time (hh:mm:ss)
4/29/**** 8:08:00 PM	1ST FL	Other	41:19:43
3/31/**** 1:33:00 PM	1ST FL	Other	26:20:04
5/30/**** 7:23:00 PM	1ST FL	Other	16:48:08
7/8/**** 11:08:00 PM	1ST FL	Other	13:12:15
9/3/**** 11:08:00 PM	1ST FL	Other	12:56:56
2/4/**** 8:32:00 PM	210	Pendan	12:30:18
1/11/**** 8:21:00 PM	305	Bath	12:27:54
6/14/**** 12:17:00 AM	1ST FL	Other	12:23:31
9/2/**** 11:28:00 PM	1ST FL	Other	12:12:40
1/21/**** 8:12:00 PM	1ST FL	Other	11:45:36
7/14/**** 11:42:00 PM	1ST FL	Other	11:03:50
8/26/**** 12:24:00 AM	1ST FL	Other	10:45:03
1/11/**** 11:00:00 PM	1ST FL	Other	10:32:13
6/7/**** 11:14:00 PM	1ST FL	Other	10:21:03
4/29/**** 6:25:00 AM	1ST FL	Other	10:12:33
4/21/**** 12:42:00 AM	2ND FL	Other	9:46:47
3/21/**** 11:04:00 PM	1ST FL	Other	9:46:46

803

1 2 3 4 5 6 7 8 9 10 ...

Done

801

FIG. 8

900

Client Area - SEM
File Edit View Go Bookmarks Tools Help del: jcio.us

Enterprise Manager
Dashboard Trends for Mobile Device Manage My Account

Logged in as jsmth715 Logout

Trends

Community [All] View Data

Community	Response Time (min)
STT Building 1	1.02
STT Building 2	0.90

Responses Time Tasks

Threshold (min): Lower 240 Upper 720

Start Date: End Date:

Community	Event Date	Response Time (minutes)
STT Building 1	1/10/00 5:55:00 PM	1.005025
STT Building 1	1/10/00 5:55:00 PM	1.005022
STT Building 1	1/10/00 5:55:00 PM	1.005009
STT Building 1	1/10/00 5:57:00 PM	1.005007
STT Building 1	1/10/00 5:57:00 PM	1.004939
STT Building 1	1/10/00 5:58:00 PM	1.004915
STT Building 1	1/10/00 5:58:00 PM	1.004747
STT Building 1	1/10/00 6:00:00 PM	1.004641
STT Building 1	1/10/00 6:01:00 PM	1.004633
STT Building 1	1/10/00 6:05:00 PM	1.004216

< Prev Day Next Day

Key Drivers

Community [All] View Data

Event Date	Volume
02/01/00	50.81K
02/02/00	49.80K
02/03/00	46.74K
02/04/00	44.50K
02/05/00	41.41K
02/06/00	36.96K
02/07/00	37.16K
02/08/00	35.15K
02/09/00	33.43K
02/10/00	31.44K
02/11/00	24.00K
02/12/00	24.00K
03/01/00	36.00K
03/02/00	48.00K
03/03/00	60.00K

Transferring data from webaddress.com

Call Volume Tasks

Threshold (volume of calls): Lower 25 Upper 50

Start Date: End Date:

Community	Event Date	Volume
STT Building 1	02/02/00	135 Events
STT Building 1	02/02/00	128 Events
STT Building 1	01/26/00	106 Events
STT Building 1	01/26/00	106 Events
STT Building 1	01/26/00	106 Events
STT Building 1	01/26/00	106 Events
STT Building 1	01/25/00	106 Events
STT Building 1	01/25/00	106 Events
STT Building 1	01/26/00	106 Events
STT Building 1	01/26/00	106 Events

905

907

901

903

FIG. 9

1000

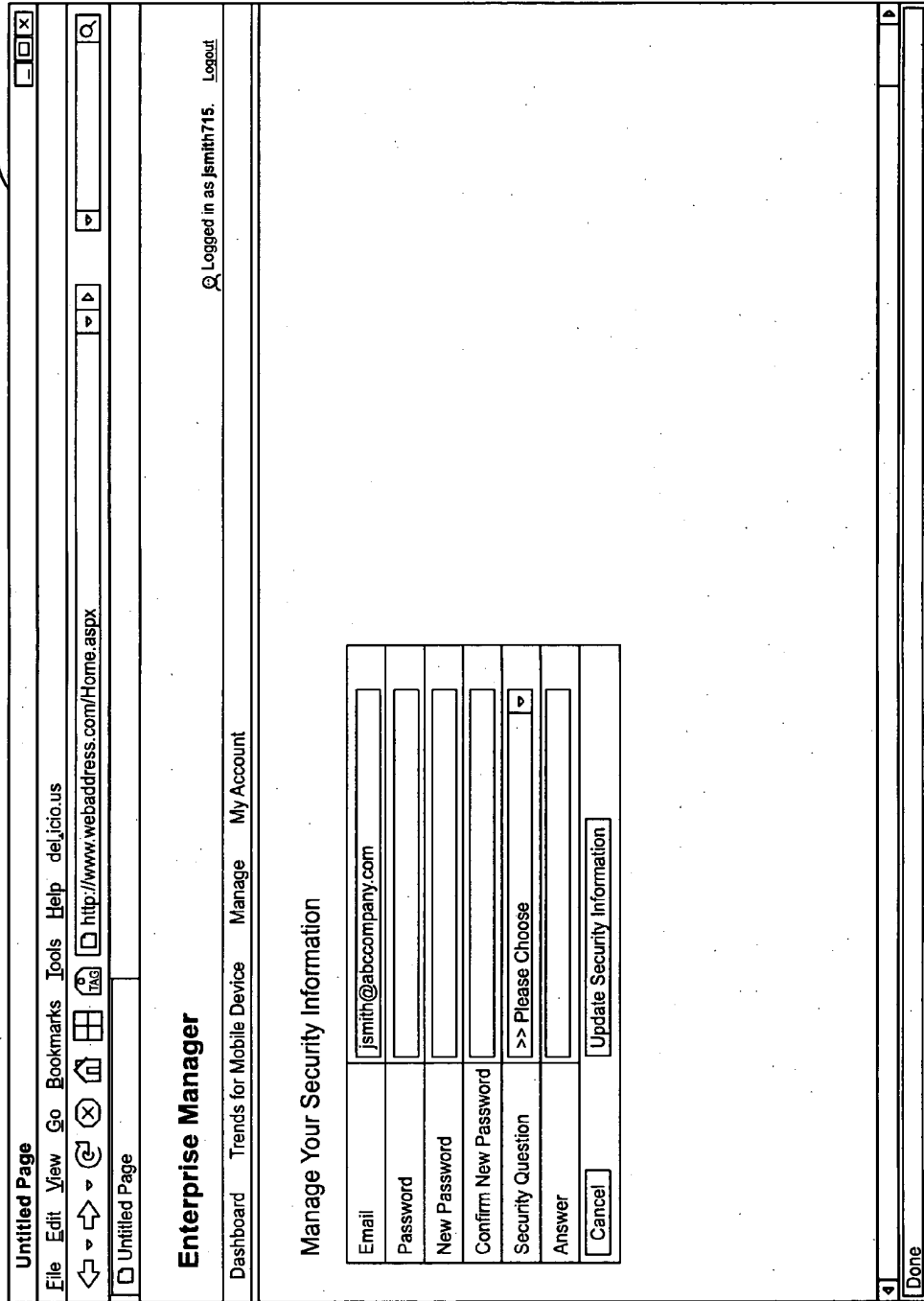

FIG. 10

1100

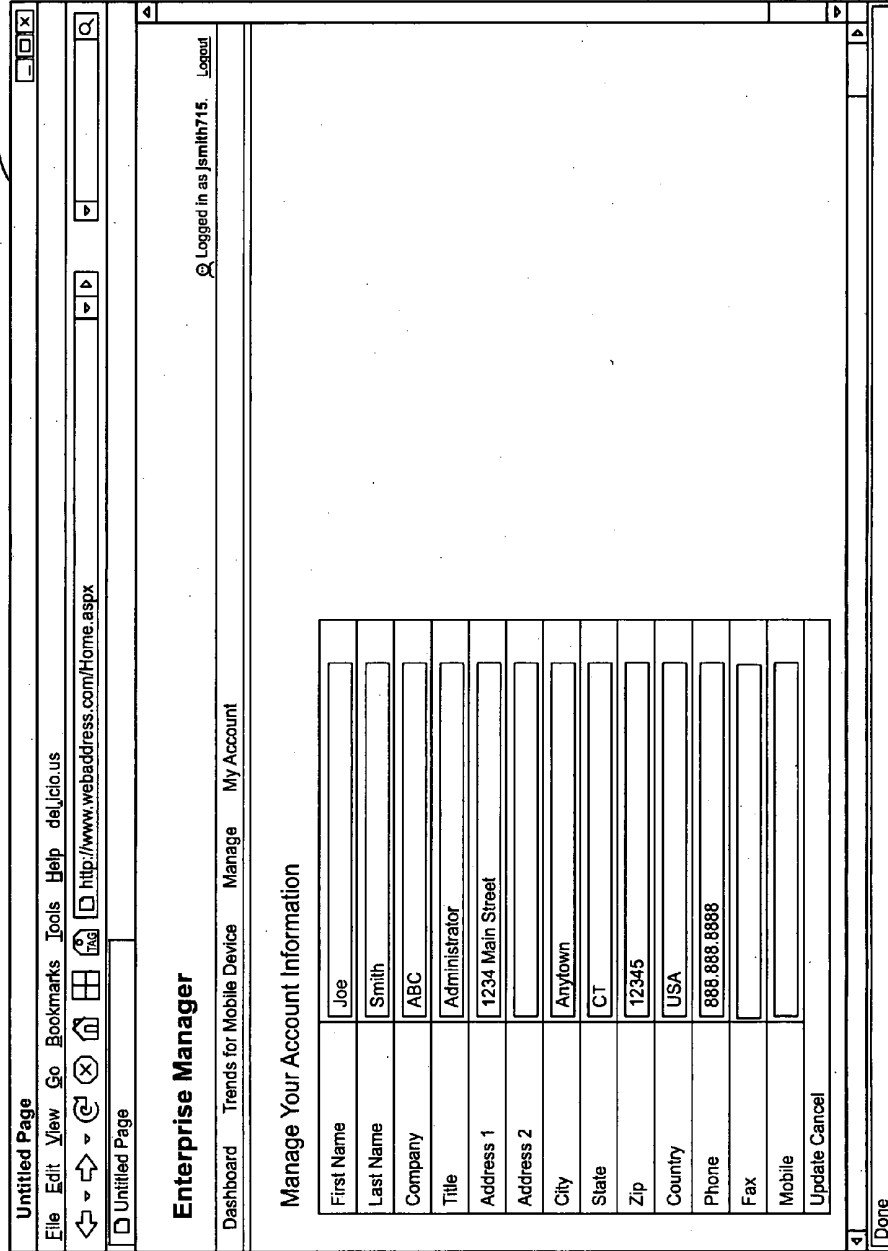

FIG. 11

1200

Untitled Page
File Edit View Go Bookmarks Tools Help de.jdo.us

http://www.webaddress.com/home.aspx

Logged in as jsmith715 Logout

Enterprise Manager

Dashboard Trends for Mobile Device Manage My Account

Manage User Accounts

First Name	Last Name	Is Approved	Created	Last Login	Roles
Jane	Doe	<input checked="" type="checkbox"/>	1/26/2008 4:55:51 PM	2/26/2008 5:56:49 PM	Admin, Manager
Jane	Doe	<input checked="" type="checkbox"/>	12/20/2007 1:52:57 AM	2/1/2008 10:44:33 PM	Admin, Manager
Jane	Doe	<input type="checkbox"/>	2/26/2008 5:49:20 PM	2/26/2008 5:49:20 PM	Admin, Manager
Joe	Smith	<input checked="" type="checkbox"/>	12/21/2007 3:51:18 PM	2/26/2008 6:12:21 PM	Admin, Manager
Joe	Smith	<input checked="" type="checkbox"/>	12/27/2007 6:56:07 PM	2/26/2008 3:06:15 PM	Admin, Manager
John	Doe	<input checked="" type="checkbox"/>	12/27/2007 6:52:15 PM	2/26/2008 3:06:13 PM	Manager
John	Doe	<input checked="" type="checkbox"/>	1/5/2008 5:27:36 PM	1/5/2008 5:27:36 PM	Admin, Manager
John	Doe	<input checked="" type="checkbox"/>	1/5/2008 5:25:20 PM	1/5/2008 5:25:20 PM	Admin, Manager

Is Approved

Admin

Manager

Communities: STI Building 1, STI Building 2

Create Date: 12/21/2007 3:51:18 PM

Last Login Date: 2/26/2008 6:12:21 PM

Email Login Info?

Cancel Update Access

1203

First Name: Joe

Last Name: Smith

Title: Manager

Address 1: 1234 Main Street

Address 2:

City: Anytown

State: CT

Zip: 12345

Country: USA

Company: ABC

Phone: 888.888.8888

Fax: 888.888.8888

Mobile: 888.888.8888

Cancel Update Account

Done

1201

FIG. 12

1300

Untitled Page

File Edit View Go Bookmarks Tools Help delicio.us

http://www.webaddress.com/Home.aspx

Untitled Page

Logged in as Jsmith715 Logout

Enterprise Manager

Dashboard Trends for Mobile Device Manage My Account

Manage Communities

Community Id	9
Community Name	STI Building 1
Database Name	SEM_STI Building 1
Update Cancel	

Community Id	Community Name	DB Name	Delete Select	Delete Select
9	STI Building 1	SEM_STI Building 1	Delete Select	Delete Select
10	STI Building 2	SEM_STI Building 2	Delete Select	Delete Select

Done

1303

1301

FIG. 13

1400

Manage Regions - SEM
File Edit View Go Bookmarks Tools Help del.icio.us
http://www.webaddress.com/Home.aspx
Manage Regions

Enterprise Manager
Dashboard Trends for Mobile Device Manage My Account
Logged in as jsmith715 Logout

Manage Regions

Region Id: 26
Region Name: another one
Communities: STI Building 1, STI Building 2
Update Cancel

Region Id	Region Name	Delete Select
26	another one	Delete Select
22	East	Delete Select
20	North	Delete Select
21	South	Delete Select
23	West	Delete Select

Done

1403

1401

FIG. 14

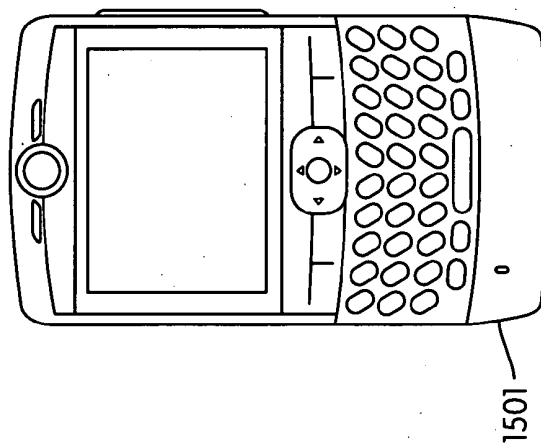

FIG. 15A

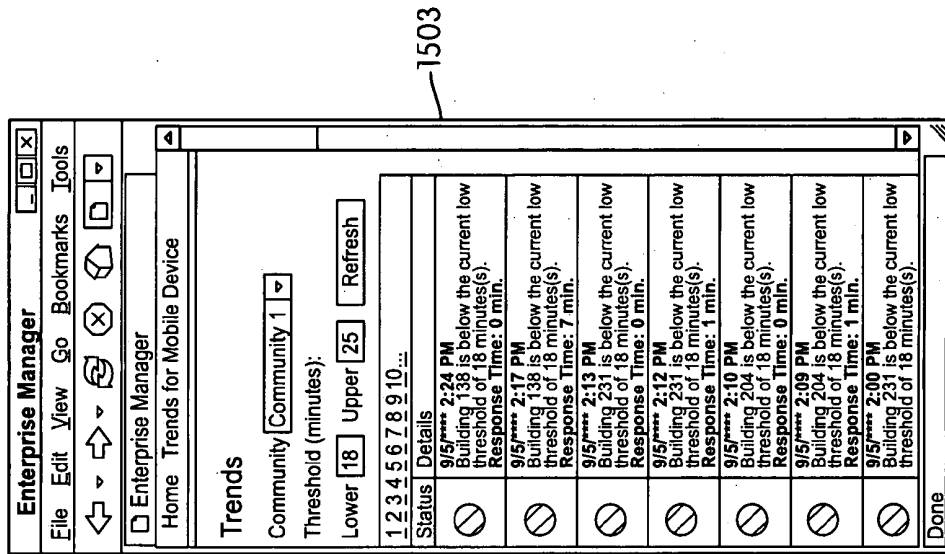

FIG. 15B

1600

Tasks Alerts - SEM
File Edit View Go Bookmarks Tools Help deljcio.us

Task Alerts - SEM

Enterprise Manager

Dashboard Trends for Mobile Device Manage My Account

Manage Task Alerts

Please select a task from the list.

Task Id	Event Date	Assigned Date	Task Type	Task Status	Community
<input type="radio"/>	7/6/**** 1:56:00 PM	11/4/**** 5:54:37 PM	Trend	Open	Community A
<input type="radio"/>	7/6/**** 1:57:00 PM	11/6/**** 10:57:56 AM	Trend	Closed	Community A
<input type="radio"/>	6/30/**** 12:00:00 AM	11/6/**** 4:56:08 PM	KeyDriver	Closed	Community A
<input type="radio"/>	8/8/**** 7:13:00 AM	11/20/**** 3:36:34 PM	Trend	Closed	Community A
<input type="radio"/>	9/5/**** 12:00:00 AM	11/20/**** 3:49:12 PM	KeyDriver	Open	Community B
<input type="radio"/>	7/30/**** 7:42:00 AM	11/22/**** 11:55:57 AM	Trend	Closed	Community C
<input type="radio"/>	8/8/**** 7:13:00 AM	12/14/**** 3:42:32 PM	Trend	Closed	Community A
<input type="radio"/>	8/8/**** 7:13:00 AM	12/21/**** 11:12:18 AM	Trend	Open	Community A
<input type="radio"/>	8/8/**** 7:13:00 AM	12/21/**** 11:13:12 AM	Trend	Open	Community A

Done

1601

FIG. 16A

1620

Logged in as jsmith715. Logout

Enterprise Manager

Dashboard Trends for Mobile Device Manage My Account

Manage Task Alerts

Taskid	9
TaskStatus	Closed
AssignedTo	Jane Doe
AssignedToEmail	info@acme.net
AssignedToDate	11/6/**** 4:56:08 PM
Community	Community A
Apartment
EventDate	6/30/**** 12:00:00 AM
ResponseTime	25 Events
CallVolume	dfbazfbazdf
Message	
Edit Delete	

Task Id	Event Date	Assigned Date	Task Type	Task Status	Community
7	7/6/**** 1:56:00 PM	11/4/**** 5:54:37 PM	Trend	Open	Community A
8	7/6/**** 1:57:00 PM	11/6/**** 10:57:56 AM	Trend	Closed	Community A
9	6/30/**** 12:00:00 AM	11/6/**** 4:56:08 PM	KeyDriver	Closed	Community A
10	8/8/**** 7:13:00 AM	11/20/**** 3:36:34 PM	Trend	Closed	Community A
11	9/5/**** 12:00:00 AM	11/20/**** 3:49:12 PM	KeyDriver	Open	Community B
12	7/30/**** 7:42:00 AM	11/22/**** 11:55:57 AM	Trend	Closed	Community C
13	8/8/**** 7:13:00 AM	12/14/**** 3:42:32 PM	Trend	Closed	Community A

1621

1601

FIG. 16B

1640

1641

1645

Done

1643

1644

1642

1646

1647

1648

1649

1650

1651

1652

1653

1654

1655

1656

1657

1658

1659

1660

1661

1662

1663

1664

1665

1666

1667

1668

1669

1670

1671

1672

1673

1674

1675

1676

1677

1678

1679

1680

1681

1682

1683

1684

1685

1686

1687

1688

1689

1690

1691

1692

1693

1694

1695

1696

1697

1698

1699

1700

1701

1702

1703

1704

1705

1706

1707

1708

1709

1710

1711

1712

1713

1714

1715

1716

1717

1718

1719

1720

1721

1722

1723

1724

1725

1726

1727

1728

1729

1730

1731

1732

1733

1734

1735

1736

1737

1738

1739

1740

1741

1742

1743

1744

1745

1746

1747

1748

1749

1750

1751

1752

1753

1754

1755

1756

1757

1758

1759

1760

1761

1762

1763

1764

1765

1766

1767

1768

1769

1770

1771

1772

1773

1774

1775

1776

1777

1778

1779

1780

1781

1782

1783

1784

1785

1786

1787

1788

1789

1790

1791

1792

1793

1794

1795

1796

1797

1798

1799

1800

1801

1802

1803

1804

1805

1806

1807

1808

1809

1810

1811

1812

1813

1814

1815

1816

1817

1818

1819

1820

1821

1822

1823

1824

1825

1826

1827

1828

1829

1830

1831

1832

1833

1834

1835

1836

1837

1838

1839

1840

1841

1842

1843

1844

1845

1846

1847

1848

1849

1850

1851

1852

1853

1854

1855

1856

1857

1858

1859

1860

1861

1862

1863

1864

1865

1866

1867

1868

1869

1870

1871

1872

1873

1874

1875

1876

1877

1878

1879

1880

1881

1882

1883

1884

1885

1886

1887

1888

1889

1890

1891

1892

1893

1894

1895

1896

1897

1898

1899

1900

1901

1902

1903

1904

1905

1906

1907

1908

1909

1910

1911

1912

1913

1914

1915

1916

1917

1918

1919

1920

1921

1922

1923

1924

1925

1926

1927

1928

1929

1930

1931

1932

1933

1934

1935

1936

1937

1938

1939

1940

1941

1942

1943

1944

1945

1946

1947

1948

1949

1950

1951

1952

1953

1954

1955

1956

1957

1958

1959

1960

1961

1962

1963

1964

1965

1966

1967

1968

1969

1970

1971

1972

1973

1974

1975

1976

1977

1978

1979

1980

1981

1982

1983

1984

1985

1986

1987

1988

1989

1990

1991

1992

1993

1994

1995

1996

1997

1998

1999

2000

2001

2002

2003

2004

2005

2006

2007

2008

2009

2010

2011

2012

2013

2014

2015

2016

2017

2018

2019

2020

2021

2022

2023

2024

2025

2026

2027

2028

2029

2030

2031

2032

2033

2034

2035

2036

2037

2038

2039

2040

2041

2042

2043

2044

2045

2046

2047

2048

2049

2050

2051

2052

2053

2054

2055

2056

2057

2058

2059

2060

2061

2062

2063

2064

2065

2066

2067

2068

2069

2070

2071

2072

2073

2074

2075

2076

2077

2078

2079

2080

2081

2082

2083

2084

2085

2086

2087

2088

2089

2090

2091

2092

2093

2094

2095

2096

2097

2098

2099

2100

2101

2102

2103

2104

2105

2106

2107

2108

2109

2110

2111

2112

2113

2114

2115

2116

2117

2118

2119

2120

2121

2122

2123

2124

2125

2126

2127

2128

2129

2130

2131

2132

2133

2134

2135

2136

2137

2138

2139

2140

2141

2142

2143

2144

2145

2146

2147

2148

2149

2150

2151

2152

2153

2154

2155

2156

2157

2158

2159

2160

2161

2162

2163

2164

2165

2166

2167

2168

2169

2170

2171

2172

2173

2174

2175

2176

2177

2178

2179

2180

2181

2182

2183

2184

2185

2186

2187

2188

2189

2190

2191

2192

2193

2194

2195

2196

2197

2198

2199

2200

2201

2202

2203

2204

2205

2206

2207

2208

2209

2210

2211

2212

2213

2214

2215

2216

2217

2218

2219

2220

2221

2222

2223

2224

2225

2226

2227

2228

2229

2230

2231

2232

2233

2234

2235

2236

2237

2238

2239

2240

2241

2242

2243

2244

2245

2246

2247

2248

2249

2250

2251

2252

2253

2254

2255

2256

2257

2258

2259

2260

2261

2262

2263

2264

2265

2266

2267

2268

2269

2270

2271

2272

2273

2274

2275

2276

2277

2278

2279

2280

2281

2282

2283

2284

2285

2286

2287

2288

2289

2290

2291

2292

2293

2294

2295

2296

2297

2298

2299

2300

2301

2302

2303

2304

2305

2306

2307

2308

2309

2310

2311

2312

2313

2314

2315

2316

2317

2318

2319

2320

2321

2322

2323

2324

2325

2326

2327

2328

2329

2330

2331

2332

2333

2334

2335

2336

2337

2338

2339

2340

2341

2342

2343

2344

2345

2346

2347

2348

2349

2350

2351

2352

2353

2354

2355

2356

2357

2358

2359

2360

2361

2362

2363

2364

2365

2366

2367

2368

2369

2370

2371

2372

2373

2374

2375

2376

2377

2378

2379

2380

2381

2382

2383

2384

2385

2386

2387

2388

2389

2390

2391

2392

2393

2394

2395

2396

2397

2398

2399

2400

2401

2402

2403

2404

2405

2406

2407

2408

2409

2410

2411

2412

2413

2414

2415

2416

2417

2418

2419

2420

2421

2422

2423

2424

2425

2426

2427

2428

2429

2430

2431

2432

2433

2434

2435

2436

2437

2438

2439

2440

2441

2442

2443

2444

2445

2446

2447

2448

2449

2450

2451

2452

2453

2454

2455

2456

2457

2458

2459

2460

2461

2462

2463

2464

2465

2466

2467

2468

2469

2470

2471

2472

2473

2474

2475

2476

2477

2478

2479

2480

2481

2482

2483

2484

2485

2486

2487

2488

2489

2490

2491

2492

2493

2494

2495

2496

2497

2498

2499

2500

2501

2502

2503

2504

2505

2506

2507

2508

2509

2510

2511

2512

2513

2514

2515

2516

2517

2518

2519

2520

2521

2522

2523

2524

2525

2526

2527

2528

2529

2530

2531

2532

2533

2534

2535

2536

2537

2538

2539

2540

2541

2542

2543

2544

2545

2546

2547

2548

2549

2550

2551

2552

2553

2554

2555

2556

2557

2558

2559

2560

2561

2562

2563

2564

2565

2566

2567

2568

2569

2570

2571

2572

2573

2574

2575

2576

2577

2578

2579

2580

2581

2582

2583

2584

2585

2586

2587

2588

2589

2590

2591

2592

2593

2594

2595

2596

2597

2598

2599

2600

2601

2602

2603

2604

2605

2606

2607

2608

2609

2610

2611

2612

2613

2614

2615

2616

2617

2618

2619

2620

2621

2622

2623

2624

2625

2626

2627

2628

2629

2630

2631

2632

2633

2634

2635

2636

2637

2638

2639

2640

2641

2642

2643

2644

2645

2646

2647

2648

2649

2650

2651

2652

2653

2654

2655

2656

2657

2658

2659

2660

2661

2662

2663

2664

2665

2666

2667

2668

2669

2670

2671

2672

2673

2674

2675

2676

2677

2678

2679

2680

2681

2682

2683

2684

2685

2686

2687

2688

2689

2690

2691

2692

2693

2694

2695

2696

2697

2698

2699

2700

2701

2702

2703

2704

2705

2706

2707

2708

2709

2710

2711

2712

2713

2714

2715

2716

2717

2718

2719

2720

2721

2722

2723

2724

2725

2726

2727

2728

2729

2730

2731

2732

2733

2734

2735

2736

2737

2738

2739

2740

2741

2742

2743

2744

2745

2746

2747

2748

2749

2750

2751

2752

2753

2754

2755

2756

2757

2758

2759

2760

2761

2762

2763

2764

2765

2766

2767

2768

2769

2770

2771

2772

2773

2774

2775

2776

2777

2778

2779

2780

2781

2782

2783

2784

2785

2786

2787

2788

2789

2790

2791

2792

2793

2794

2795

2796

2797

2798

2799

2800

2801

2802

2803

2804

2805

2806

2807

2808

2809

2810

2811

2812

2813

2814

2815

2816

2817

2818

2819

2820

2821

2822

2823

2824

2825

2826

2827

2828

2829

2830

2831

2832

2833

2834

2835

2836

2837

2838

2839

2840

2841

2842

2843

2844

2845

2846

2847

2848

2849

2850

2851

2852

2853

2854

2855

2856

2857

2858

2859

2860

2861

2862

2863

2864

2865

2866

2867

2868

2869

2870

2871

2872

2873

2874

2875

2876

2877

2878

2879

2880

2881

2882

2883

2884

2885

2886

2887

2888

2889

2890

2891

2892

2893

2894

2895

2896

2897

2898

2899

2900

2901

2902

2903

2904

2905

2906

2907

2908

2909

2910

2911

2912

2913

2914

2915

2916

2917

2918

2919

2920

2921

2922

2923

2924

2925

2926

2927

2928

2929

2930

2931

2932

2933

2934

2935

2936

2937

2938

2939

2940

2941

2942

2943

2944

2945

2946

2947

2948

2949

2950

2951

2952

2953

2954

2955

2956

2957

2958

2959

2960

2961

2962

2963

2964

2965

2966

2967

2968

2969

2970

2971

2972

2973

2974

2975

2976

2977

2978

2979

2980

2981

2982

2983

2984

2985

2986

2987

2988

2989

2990

2991

2992

2993

2994

2995

299

FACILITY MANAGEMENT SYSTEM

BACKGROUND OF THE INVENTION

[0001] 1. Field of the Invention

[0002] The invention relates to methods and systems for monitoring and managing multiple aspects of assisted living facilities, particularly, utilizing multiple monitoring devices present at assisted living facilities to gather information for an enterprise management application.

[0003] 2. Description of Related Art

[0004] Health care facilities, including assisted living facilities that cater to the elderly and disabled, face an arduous task of monitoring their day to day operations. Assisted living facilities are under particular pressure to maintain a consistently high standard of care. Aspects of assisted living facility management other than patient care, such as, assistance response time, employee time, security and access control, equipment upkeep, medication distribution, or other areas, may be relevant when a patient (or relative thereof) is choosing an assisted living facility. Furthermore, entities operating multiple assisted living facilities face still additional challenges when attempting to monitor and manage the various aspects of these multiple facilities.

[0005] Often times, managers or other personnel involved with operating multiple assisted living facilities may be remotely located from some or all of the assisted living facilities. As such, collection, aggregation, and analysis of data for basic management tasks, identifying various conditions, assistance response times, identifying underperforming facilities, identifying over-performing facilities, trend analysis, and/or other data can be unwieldy.

[0006] Accordingly, there is a need for systems and methods for monitoring multiple aspects of multiple assisted living facilities and providing data regarding those multiple aspects to various remote locations.

BRIEF SUMMARY OF THE INVENTION

[0007] The present invention relates to systems and methods that enable management of multiple assisted living facilities regardless of the geographic distribution of the facilities and/or the location of facility management personnel. As such, one aspect of the invention provides a system for acquiring, manipulating, and/or monitoring data regarding one or more assisted living facilities according to an embodiment of the invention. The system also enables management of the facilities associated with the system via various communication methods.

[0008] In some embodiments, a management system according to the invention may comprise an enterprise management application, a database, and/or other elements. The system may communicate/interact with one or more assisted living facilities (including various monitoring devices and computer systems of those facilities), one or more users, and/or other entities via a network (e.g., the Internet and/or other computer network).

[0009] The enterprise management application may comprise an Internet web site, an intranet site, or other host site or computer application maintained on the system of the invention. The enterprise management application may include one or more software modules for gathering data from monitoring devices of assisted living facilities and their associated systems, transmitting the data across a network, receiving the data, examining/processing the data, storing the data in a

database, receiving data manipulation instructions (e.g., report parameters, query parameters, alert parameters, task parameters, or other instructions), manipulating the data, enabling one or more interfaces for the receipt of data and/or instructions, enabling one or more interfaces for the presentation of data, enabling the production and transmittal of alerts or tasks, establishing and editing one or more user accounts, and/or for performing other features of functions of the invention.

[0010] As used herein, an assisted living facility may include a facility wherein medical care and/or permanent or temporary residence is provided for the elderly, the physically disabled, the mentally disabled, other those otherwise in need of a facility providing both medical care and residential services. In some embodiments, other health care services and facilities (e.g., hospitals, hospices, home health care service, EMT/EMS services) may be used in conjunction with the invention.

[0011] Assisted living facilities may include and/or interface with one or more monitoring devices. A monitoring device used by the system may include any device or system that that enables the gathering of information regarding an assisted living facility. In some embodiments, a monitoring device may include a device that is fixed at an assisted living facility. In some embodiments, a monitoring device may include a device or system that is not necessarily permanently present at an assisted living facility (e.g., devices carried or worn by patients or employees, who may leave the facility).

[0012] In many instances, as will be seen by the description herein, monitoring devices may include devices or systems that serve a separate function, but which gather, record, or pass data regarding performance of that separate function, thus monitoring the separate function. For example, in some embodiments, monitoring devices may include devices and systems involved in patient safety at an assisted living facility. These devices and systems may include, for example, medical alert pendants having transmitters therein that are typically worn by patients. The transmitter, when activated by the patient, may send a signal indicating that the patient requesting assistance. The pendant itself, and/or the associated system receiving the signal, may act as a monitoring device by the fact that information associated with the signal is logged and/or recorded and ultimately transmitted to, and stored in, a central management database.

[0013] Other patient-related devices or systems, such as, for example, blood pressure monitors, heart rate monitors, blood gas monitors, respiration monitors, temperature monitors, in-room distress devices (e.g., a button on a wall or piece of furniture, as opposed to mobile pendants), nurse call buttons, and/or other devices/systems may act as monitoring devices. Information from these devices and systems may be logged, recorded or otherwise captured, transmitted across a network, and stored in a management database.

[0014] In some embodiments, monitoring devices may include video cameras, monitors, and/or associated equipment. For example, in some embodiments, video cameras and monitors may be used to monitor patients and record and/or trigger a patient distress events. In some embodiments, personnel may monitor video feed and manually trigger a patient alert or other patient event. In other embodiments, video feeds may be automatically monitored and alerts/events may be automatically triggered.

[0015] Other patient safety related systems may similarly act as monitoring devices. For example, staff members of an

assisted living facility may wear/carry pendants, pagers, phones, handheld computers, or other devices that transmit signals related to when medical personnel has arrived at a patient whose pendant has transmitted a request for assistance signal (or for whom such a signal has been otherwise initiated). When a patient distress signal is detected, medical staff may be dispatched to the patient's location. Upon reaching the patient, the dispatched personnel may utilize their response devices to transmit a signal to a system that indicates help has arrived at the patient. In this manner, response times or other information related to patient safety may be monitored and transmitted to a management database. As such, the staff devices and/or their associated systems (which may be the same systems associated with the patient pendants) may also be considered patient monitoring devices.

[0016] Devices and systems related to other aspects of assisted living facilities may be considered monitoring devices. For example, in some embodiments, employee time logging systems, such as systems whereby employees of an assisted living facility indicate their time worked, may act as monitoring devices whereby data regarding employee time may be collected, recorded, or otherwise captured, transmitted across a network, and stored in a management database.

[0017] In some embodiments, security and access control devices and systems may act as monitoring devices. For example, entry and exit control systems, motion control sensors, equipment security systems (e.g., anti-theft systems), or other security systems may be utilized to gather data that is recorded, or otherwise captured, transmitted across a network, and stored in a management database for use by the management system. Alone or in conjunction with the above mentioned security systems, automatic door or other entry and exit control systems may be utilized as monitoring devices. Similarly, drug and medication logs and security systems may be utilized as monitoring devices for gathering data for the management system.

[0018] In some embodiments, equipment service records and systems for equipment servicing may be used as monitoring devices. For example, time between servicing, frequency of service, type of service, and/or other service related information may be collected, transmitted across a network, and stored in a management database.

[0019] Assisted living facilities may include computer-implemented devices and/or systems necessary to gather/receive data from various monitoring devices, store this data (at least temporarily), connect with network (e.g., modems, etc.), transmit data across a network to the management system, and/or perform other features or functions of the invention. These computer-implemented devices and systems may be or include one or more servers, desktop computers, laptop computers, handheld computers, personal digital assistants, cell phones, smart phones, modems, or other computer implemented devices.

[0020] Users of the management system may include managers, medical personnel, administrative personnel, other employees of assisted living facilities, or other parties with an interest in monitoring operation of one or more aspects of assisted living facilities (e.g., consultants, auditors, government entities, regulators, relatives of patients, or other parties) that may access the management system via a network.

[0021] Users may access the management system using one or more computer-implemented user devices. A user device may include a server, a desktop computer, a laptop computer, a dumb terminal, a handheld computer, a personal digital

assistant, a cell phone, a smart phone, pager, or other computer-implemented device, whether wireless or not. Users may utilize a graphical user interface to interact and/or interface with the management system. In some embodiments, one or more modules of the enterprise management application (e.g., an interface module) may support graphical user interfaces or other interfaces of the invention.

[0022] The invention also includes a process for acquiring, manipulating, and monitoring data associated with assisted living facilities. In one embodiment, one or more event monitoring devices record or otherwise collect data regarding events and operations of one or more assisted living-facilities. As described above, the events and operations associated with an assisted living facility may include data regarding patients of facilities (including patient distress events or calls and response times to those events or calls), employee time, security systems, entry/exit control systems, drug or medication dispensing, equipment service, and/or other data.

[0023] The data associated with the events and/or operations of assisted living facilities may then be transmitted from the assisted living facilities, over a network (e.g., the Internet and/or other computer network), where it is received by an assisted living facility management system. In some embodiments, the data may be sent to the management system as it is collected by monitoring devices. In some embodiments, the data may be gathered and at least temporarily stored in one or more computer systems of an assisted living facility or other systems and sent to the management system at a later time.

[0024] In some embodiments, the data received at the management system from the monitoring devices may then be processed prior to storing the data in a system database. For example, the data may be checked for completeness, for obvious entry errors or data originating from malfunctioning monitoring devices, which may be flagged for follow-up or disposal, and/or for other purposes. The processed data may then be stored in a system database.

[0025] The stored data may then be queried, filtered, analyzed, and or otherwise manipulated for any number of uses. In some embodiments, the stored data may be utilized to construct one or more reports, alerts, tasks, and/or other documents/communications associated with one or more aspects of one or more assisted living communities. One or more modules (e.g., a query module, a report module, or other module) of the enterprise management application may enable querying, filtering, report generation, alert generation, task generation, and/or other manipulation of data stored in the system database.

[0026] The stored data may then be accessed by, or presented to, one or more users via one or more user devices. In some embodiments, one or more modules (e.g., an interface module) of the enterprise application may enable a portal accessible via a network, whereby one or more users may access data regarding one or more aspects of one or more assisted living facilities. In some embodiments, the portal may be a web portal accessible via the internet and may include multiple graphical user interfaces and/or other interfaces enabled by the enterprise management application. This web portal may enable a user to not only view the data but may enable a user to enter information and/or direct manipulation of the data.

[0027] For example, users, interacting via the portal or other interface of the invention, may specify report or query parameters for the generation of reports or query results. These parameters may then be applied to the data in the

system database to generate a report or query result for presentation to users. The report or result may then be displayed to users in a graphical user interface.

[0028] As described above, users may access the management system and associated databases of the invention using mobile or wireless user devices. As such, one or more modules (e.g., an interface module) of the enterprise management application may enable the portal to present graphical user interfaces compatible with mobile devices.

[0029] In some embodiments, the enterprise management application may enable alerts and/or tasks to be sent to one or more users. For example, in some embodiments, alerts may be sent to high level business managers to keep them apprised of the operations of one or more assisted living facilities or for other purposes. In some embodiments, alerts may be sent to facility managers or health care staff on site at an assisted living facility to keep them apprised of conditions at the assisted living facility, to assign tasks to certain personnel, or for other purposes. In some embodiments, alerts and/or tasks may be sent to other users.

[0030] In some embodiments, the invention may include a computer/processor-readable medium that includes computer/processor-readable code that causes a processor, computer, or other computer system or part thereof to acquire and manipulate data associated with one or more assisted living facilities and otherwise enable monitoring and management of the one or more facilities. As such, the computer/processor readable code includes code for performing some or all of the features and functions described herein such as, for example, gathering data from monitoring devices and their associated systems, transmitting the data across a network, receiving the data, examining/processing the data, storing the data in a database, receiving data manipulation instructions (e.g., report parameters, query parameters, alert parameters, or other instructions), manipulating the data, enabling one or more interfaces for the receipt of data and/or instructions, enabling one or more interfaces for the presentation of data, enabling the production and transmittal of alerts or tasks, and/or for enabling other features or functions of the invention.

[0031] These and other objects, features, and advantages of the invention will be apparent through the detailed description and the drawings attached hereto. It is also to be understood that both the foregoing summary and the following detailed description are exemplary and not restrictive of the scope of the invention.

BRIEF DESCRIPTION OF THE DRAWINGS

[0032] FIG. 1A illustrates an example of a system for acquiring, manipulating and monitoring data regarding one or more assisted living facilities according to various embodiments of the invention.

[0033] FIG. 1B illustrates an example of a medical alert pendant and its associated computer system, according to various embodiments of the invention.

[0034] FIG. 1C illustrates an example of a patient wearing a medical alert pendant according to various embodiments of the invention.

[0035] FIG. 2 illustrates an example of a process for acquiring, manipulating, and monitoring data regarding assisted living facilities according to various embodiments of the invention.

[0036] FIG. 3 illustrates an example of a graphical user interface according to various embodiments of the invention.

[0037] FIG. 4 illustrates an example of a graphical user interface according to various embodiments of the invention.

[0038] FIG. 5 illustrates an example of a graphical user interface according to various embodiments of the invention.

[0039] FIG. 6 illustrates an example of a graphical user interface according to various embodiments of the invention.

[0040] FIG. 7 illustrates an example of a graphical user interface according to various embodiments of the invention.

[0041] FIG. 8 illustrates an example of a graphical user interface according to various embodiments of the invention.

[0042] FIG. 9 illustrates an example of a graphical user interface according to various embodiments of the invention.

[0043] FIG. 10 illustrates an example of a graphical user interface according to various embodiments of the invention.

[0044] FIG. 11 illustrates an example of a graphical user interface according to various embodiments of the invention.

[0045] FIG. 12 illustrates an example of a graphical user interface according to various embodiments of the invention.

[0046] FIG. 13 illustrates an example of a graphical user interface according to various embodiments of the invention.

[0047] FIG. 14 illustrates an example of a graphical user interface according to various embodiments of the invention.

[0048] FIG. 15A illustrates an example of a mobile user device according to various embodiments of the invention.

[0049] FIG. 15B illustrates an example of a mobile device graphical user interface according to various embodiments of the invention.

[0050] FIG. 16A illustrates an example of a graphical user interface according to various embodiments of the invention.

[0051] FIG. 16B illustrates an example of a graphical user interface according to various embodiments of the invention.

[0052] FIG. 16C illustrates an example of a graphical user interface and an alert according to various embodiments of the invention.

DETAILED DESCRIPTION OF THE INVENTION

[0053] FIG. 1A illustrates an example of a system **100** for acquiring, manipulating, and monitoring data regarding one or more assisted living facilities according to an embodiment of the invention. System **100** may comprise an enterprise management application **101**, a database **103**, and/or other elements. System **100** may communicate/interact with one or more assisted living facilities **105**, one or more users **107**, and/or other entities via network **109**.

[0054] Enterprise management application **101** may comprise an Internet web site, an intranet site, or other host site or computer application maintained on system **100**. Accordingly, one or more hardware devices such as, for example, processors, servers, desktop computers, memory devices, or other devices or elements, may be included in system **100** to support enterprise management application **101**, database **103**, and/or other features and functions of the invention.

[0055] Enterprise management application **101** may include one or more software modules **111a-n** for gathering data associated with one or more assisted living facilities **105** from monitoring devices and their associated systems, transmitting the data across a network, receiving the data, examining/processing the data, storing the data in a database, receiving data manipulation instructions (e.g., report parameters, query parameters, alert parameters, task parameters, or other instructions), manipulating the data, enabling one or more interfaces for the receipt of data and/or instructions, enabling one or more interfaces for the presentation of data, enabling the production and transmittal of alerts or tasks,

establishing and editing one or more user accounts, and/or for performing other features or functions of the invention.

[0056] In particular, enterprise management application 101 may include an interface module for supporting graphical user interfaces (used for the receipt of data/instructions from users as well as the presentation of data or other interaction with system 100) and other interfaces, such as those between monitoring devices or their associated systems and system 100; a query module that enables querying of data in database 103; a report module that enables the generation of reports or other data displayed using the data from database 103, an alert module that enables the generation of alerts or tasks using data in database 103; a user account module that enables the setup and editing of one or more user accounts and associated account information; and/or other modules for performing any of the features or functions of the inventions described herein. One or more of the modules 111a-n comprising control application 101 may be combined. For some purposes, not all modules may be necessary.

[0057] According to an embodiment of the invention, database 103 may be, include, or interface to, for example, an Oracle™ relational database sold commercially by Oracle Corporation. Other databases, such as Informix™, DB2 (Database 2) or other data storage or query formats, platforms, or resources such as OLAP (On Line Analytical Processing), SQL (Standard Language Query), a SAN (storage area network), Microsoft Access™ or others may also be used, incorporated, or accessed by the invention. Database 103 may include any combination of databases or other data storage devices, and may receive and store information regarding one or more assisted living facilities, report parameters, alert preferences, task parameters, user accounts, and/or other information.

[0058] In some embodiments, enterprise management application 101 and its associated devices (e.g., servers, processors, memory, etc.) may be considered centrally located and as such may provide a central station for assisted living facility data acquisition and manipulation and for monitoring and management of geographically distributed assisted living facilities. In some embodiments, enterprise management application and its associated modules and devices may be distributed across a plurality of devices and/or locations, while still providing the features and functions of the invention.

[0059] An assisted living facility 105, may include a facility wherein medical care and/or permanent or temporary residence is provided for the elderly, the physically disabled, the mentally disabled, or those otherwise in need of a facility providing both medical care and residential services. In some embodiments, other health care services and facilities (e.g., hospitals, hospices, home health care service, EMT/EMS services) may be used in conjunction with the invention. In some embodiments, one or more assisted living facilities 105 may be geographically distributed from one another. In some embodiments, the geographical distribution may include facilities that are located in different neighborhoods, towns, cities, counties, provinces, states, countries, or otherwise geographically distributed.

[0060] Assisted living facilities 105 may include and/or interface with one or more monitoring devices 113. Monitoring devices 113 may include any device or system that enables the gathering of information associated with an assisted living facility. In some embodiments, monitoring devices 113 may include a device that is present at an assisted

living facility 105. In some embodiments, monitoring devices 113 may include devices not necessarily perpetually present at an assisted living facility 105 (e.g., such as, for example, devices worn or carried by a patient or employee).

[0061] In many instances, as will be seen by the description herein, monitoring devices 113 may include devices or systems that serve a separate function, but which gather, record, or pass data regarding performance of that separate function to system 100, thus monitoring the separate function. For example, in some embodiments, monitoring devices 113 may include devices and systems involved in patient health or safety at an assisted living facility. These devices and systems may include, for example, medical alert pendants having transmitters therein that are typically worn by patients. The transmitter, when activated by the patient, may send an alert signal indicating that the patient is in distress or otherwise indicating an event. The pendant itself, and/or the corresponding system receiving the distress signal (e.g., computer system 121 of FIG. 1B), may act as a monitoring device 113 by the fact that information associated with the distress signal is logged and or recorded and ultimately stored in database 103. Information associated with the distress signal may include, for example, the fact that the signal was sent, what pendant or other monitoring device 113 it was sent by, who (e.g., what patient) is associated with that pendant or other monitoring device 113, what apartment or room in an assisted living facility is associated with the pendant or other monitoring device 113 (the monitoring device sending the signal may be associated with a particular patient residence apartment, or may be associated with a common area, medical treatment area, or other room or area), what type of alert is associated with the signal, what assisted living facility the pendant or other monitoring device 113 is associated with, when the signal was sent, or other information associated with the distress signal. In some embodiments, this information may be initially stored by the patient monitoring system associated with the pendant (e.g., system 121 of FIG. 1B) or another system local to the assisted living facility 113 wherein the patient monitoring system resides for later transmittal via network 109 to database 103. In some embodiments, the information associated with the distress signal may be transmitted via network 109 for initial storage in database 103.

[0062] FIGS. 1B and 1C illustrate a medical alert pendant 113, which is an example of a monitoring device 113 according to some embodiments of the invention. In some embodiments, as illustrated in FIG. 1B, a medical alert pendant 113 may include an activation button 117, by which a transmitter (not illustrated) of pendant 113 may be activated/instructed to send an alert signal to associated computer system 121. In some embodiments, the pendant may include a strap 119, which may aid in a patient 123 wearing the pendant, for example, around the neck, as illustrated in FIG. 1C. Other types of medical alert devices and/or other monitoring devices 113 may be used with the invention.

[0063] Other patient-related devices or systems, such as, for example, blood pressure monitors, heart rate monitors, blood gas monitors, respiration monitors, temperature monitors, in-room distress devices (as opposed to mobile pendants), nurse call buttons, and/or other devices or systems may act as monitoring devices 113. Information from these devices and systems may be logged, recorded or otherwise captured, transmitted across network 109, and stored in database 103 for use by system 100.

[0064] In some embodiments, monitoring devices **113** may include video cameras, monitors, and/or associated equipment. For example, in some embodiments, video equipment may be used to monitor patients and record and/or trigger a patient distress event. In some embodiments, video equipment may be used to monitor other assisted living facility operations. In some embodiments, assisted living facility personnel may monitor video feeds/footage and manually trigger a patient alert or other patient event. In other embodiments, video feeds/footage may be automatically monitored and/or alerts/events may be automatically triggered.

[0065] Other patient information related systems may similarly act as monitoring devices **113**. For example, staff members of an assisted living facility **105** may wear/carry pendants, pagers, phones, handheld computers, or other devices that transmit response signals related to when medical personnel has arrived at a patient whose pendant or other monitoring device **113** has transmitted a request for assistance signal. For example, when a request for assistance signal or other signal indicative of an event is detected from a patient pendant or other monitoring device **113**, medical staff may be dispatched to the patient's location. Upon reaching the patient, the dispatched staff member(s) may utilize their staff member device to transmit a signal to a system that indicates help has arrived at the patient (e.g., a dispatched staff member may actuate a "response switch" that causes a monitoring device **113** to generate a response signal indicating the patient event has been attended to). In this manner, response times (e.g., elapsed time between the distress event signal and the response signal) or other information related to patient safety may be monitored and transmitted to database **103**. As such, the staff devices and/or their associated systems (which may be the same systems associated with the patient pendants) may also be considered patient monitoring devices **113**.

[0066] Devices and systems related to other aspects of assisted living facilities **105** may be considered monitoring devices **113**. For example, in some embodiments, employee time logging systems, such as systems whereby employees of an assisted living facility indicate their time worked, may act as monitoring devices **113**, whereby data regarding employee time may be collected, recorded, or otherwise captured, transmitted across network **109**, and stored in database **103** for use by system **100**.

[0067] In some embodiments, security and access control devices and systems may act as monitoring devices. For example, access control systems, motion sensors, equipment security systems (e.g., anti-theft systems), or other security systems may be utilized to gather data that is recorded or otherwise captured, transmitted across network **109**, and stored in database **103** for use by system **100**. Alone or in conjunction with the above mentioned security systems, automatic door or other entry and exit control systems may be utilized as monitoring devices **113**. Similarly, drug and medication logs and associated security systems may be utilized as monitoring devices **113** for gathering data for system **100**.

[0068] In some embodiments, service records and systems for equipment service recordation may be used as monitoring devices **113**. For example, time between servicing, frequency of service, information regarding specific service calls (e.g., type of service, parts replaced or operated on, service person's identity or company affiliation), or other service related information may be collected, transmitted across network **109**, and stored in database **103**.

[0069] In some embodiments, inventory records, supply purchasing records, supply disposal or usage records, and/or other supply-related records may be used as or in conjunction with monitoring devices **113**. For example, records and record keeping systems (e.g., associated computer systems, databases, paper records) related to inventory levels, purchasing of new supplies or equipment, disposal of supplies or equipment or other supply related records may be utilized to gather information related to assisted living facilities **105**.

[0070] Manual systems and devices may be used as monitoring devices **113**. For example, non-computer-implemented systems and devices may be used to manually collect data that is ultimately entered in to electronic or digital format and transmitted to database **103** across network **109** for use in system **100**. As such, manual implements, such as written log sheets, sign-in/sign-out sheets, punch card systems, and/or other manual implements and elements may be utilized as part of monitoring devices **113**. Other systems and devices may be used as monitoring device **113** to gather other types of information for use in system **100** or otherwise used as part of the invention.

[0071] Assisted living facilities **105** may include computer-implemented devices and/or systems necessary to gather/receive data from various monitoring devices **113**, store this data (at least temporarily), connect with network **109** (e.g., modems, etc.), transmit data across network **109** to database **103**, and/or perform other features or functions. These computer-implemented devices and systems may be or include one or more servers, desktop computers, laptop computers, dumb terminals, handheld computers, personal digital assistants, cell phones, smart phones, modems, or other computer-implemented devices.

[0072] It should be noted that the term assisted living facility as used herein may be analogous to the term community as used in the disclosure and one or more of the figures.

[0073] Users **107** may include managers, medical personnel, administrative personnel, other employees of assisted living facilities **105**, or other parties with an interest in monitoring operation of one or more aspects of assisted living facilities (e.g., consultants, auditors, government entities/regulators, relatives of patients, or other parties) that may access system **100** via network **109**. In some embodiments, those with access to system **100** may be restricted, depending on the intended use of system **100**. For example, in some embodiments, only management personnel of an assisted living facility **105** may have access system **100**. In some embodiments, access may be more permissive. In some embodiments, access for certain users may be limited on a per-facility basis or otherwise segmented or restricted. As discussed below, system **100** may provide an interface (see e.g., FIG. **12**) that enables certain users (e.g., high level managers) to define and/or edit the access rights of other users **107**.

[0074] Users **107** may access system **100** using one or more computer-implemented user devices. A user device may include a server, a desktop computer, a laptop computer, a dumb terminal, a handheld computer, a personal digital assistant, a cell phone, a smart phone, pager, or other computer-implemented device, whether wireless or not. Users **107** may utilize a graphical user interface **115** (GUI **115**) to interact and/or interface with system **100**. In some embodiments, one or more modules **111a-n** (e.g. an interface module) may support GUI **115**.

[0075] Network **109** may include any one or more of, for instance, the Internet, an intranet, a PAN (Personal Area Network), a LAN (Local Area Network), a WAN (Wide Area Network), a SAN (Storage Area Network), or a MAN (Metropolitan Area Network). Any suitable communications link may be utilized to connect elements of the invention to one another via network **109**, including any one or more of, for instance, a copper telephone line, a Digital Subscriber Line (DSL) connection, a Digital Data Service (DDS) connection, an Ethernet connection, an Integrated Services Digital Network (ISDN) line, an analog modem connection, a cable modem connection, wireless connection (including wireless "hot-spots"), or other connection.

[0076] System **100** and other components of FIG. **1** are illustrated in an example configuration. Other configurations may exist. Those having skill in the art will appreciate that the invention described herein may work with various configurations. Accordingly, more or less of the aforementioned components may be used and/or combined in various embodiments. It should also be understood that various software modules **111a-n**, enterprise management application **101**, and database **103**, that are utilized to accomplish the functionalities described herein may be maintained on one or more of user devices, assisted living facility devices, management devices, or other components as necessary. In other embodiments, as would be appreciated, the functionalities described herein may be implemented in various combinations of hardware and/or firmware, in addition to, or instead of, software.

[0077] FIG. **2** illustrates a process **200**, which is an example of a process for acquiring, manipulating, and monitoring data regarding assisted living facilities. Process **200** includes an operation **201**, wherein one or more monitoring devices **113** record or otherwise collect data associated with events and operations of one or more assisted living facilities **105**. As described above, the events and operations associated with an assisted living facility may include data regarding patients of facilities (including patient distress events or calls and response times to those events or calls), employee time, security systems, entry/exit control systems, drug or medication dispensing, equipment service records, supply or equipment inventory records, supply or equipment purchase records, supply or equipment disposal records, or other data.

[0078] In an operation **203**, the data associated with the events and/or operations of assisted living facilities **105** is transmitted from the assisted living facilities **105**, over network **109**, where it is received by system **100**. In some embodiments, the data may be sent to system **100** as it is collected by monitoring devices **113**. In some embodiments, the data may be gathered and at least temporarily stored in one or more computer systems of an assisted living facility **105** or other systems and sent to system **100** at a later time. In some embodiments, the transmittal of data from computer systems of assisted living facilities **105** to system **100** may occur on a predetermined interval or may occur on demand from users **107** or administrators of system **100**. In some embodiments, the data associated with events/operation of assisted living facilities **105** may be retained on the computer systems of assisted living facilities **105** after it has been sent to system **100**.

[0079] In some embodiments, one or more modules **111a-n** (e.g., interface module) of enterprise management application **101** may provide or support the interfaces necessary for

the various devices and/or systems transmitting assisted living facility data across network **109** to system **100**.

[0080] In an operation **205**, the data received from the monitoring devices **113** may be processed. In some embodiments, one or more modules **111a-n** of enterprise management application **101** may perform one or more processing operations prior to storing the data in database **103**. For example, the data may be checked for completeness, for obvious entry errors or data originating from malfunctioning monitoring devices **113**, which may be flagged for follow-up or disposal (e.g., if the average number of patient events per day equals **10** and a particular monitoring device **113** indicates that patient X had 10,000 events in one day, this may indicate an error in the data), and/or for other purposes. The processed data may be stored in database **103** in an operation **207**.

[0081] In an operation **209**, enterprise management application **101** may enable the stored data to be queried, filtered, analyzed, mined, and/or otherwise manipulated for any number of uses. In some embodiments, the stored data may be utilized to construct one or more reports, alerts, tasks, or other documents/communications regarding one or more aspects of one or more assisted living communities **105**. One or more modules **111a-n** (e.g., a query module, a report module, an alert module, or other module) of enterprise management application **101** may enable querying, filtering, report generation, alert generation, task generation, and/or other manipulation of data stored in database **103**.

[0082] In an operation **211**, the stored data may be accessed by or presented to one or more users **107**. In some embodiments, one or more of modules **111a-n** (e.g., an interface module) of enterprise management application **101** may enable a portal accessible via network **109**, whereby one or more users may access data regarding one or more aspects of one or more assisted living facilities and/or input data to system **100**. In some embodiments, the portal may be a web portal accessible via the internet (network **109**) and may include GUI **115** and/or other interfaces enabled by enterprise management application **101**. This web portal may enable a user **107** to not only view the data but may enable a user **107** to direct the manipulation of the data.

[0083] For example, users **107**, interacting via the portal or other interface of the invention, may specify report parameters for the generation of reports. These report parameters may then be applied to the data in database **103** by, for example, a report module, to generate a report for presentation to users **107**. The report may then be displayed to users **107** in a graphical user interface supported by an interface module. FIG. **3** illustrates an interface **300**, which is an example of a graphical user interface according to an embodiment of the invention. Interface **300** is an example of a report generated from specified report parameters applied to a database of assisted living facility data.

[0084] To arrive at interface **300**, a user **107** may connect his or her user device to network **109**, access the portal provided by enterprise management application **101**, and enter certain report parameters. In some embodiments, the portal may be a secure portal. As such, upon initially accessing the portal, a user **107** may be required to provide a username and/or password or comply with some other authentication/authorization scheme. A user account module of enterprise management application **101** may support one or more user accounts in database **103**, each of which may include authorization information (e.g., user name and/or password) and/or

other information associated with individual users **107**. After complying with the authorization scheme, the user may be brought to a “home” interface (e.g., homepage) from which the user may navigate through the many features provided by the portal. In some embodiments, the user may be presented with one or more options for viewing/manipulating assisted living facility data such as, for example, browse data in database **103**, browsing existing reports or automatically generated reports, enter report parameters, enter query parameters, entering alert parameters/preferences, and/or otherwise view data or direct data manipulation. These options may include any number of drop down lists, menus, check boxes, buttons, radio buttons, hyperlinks, scroll bars, text input devices, or other input regions/devices.

[**0085**] Interface **300** is a report that includes a graph depicting overall patient distress event response time across multiple assisted living facilities **105** (community **1** and community **2**) in a section **301** and a table depicting the top **10** facility alarm events for community **1** in a certain day, by apartment, in a section **303**. As mentioned above, to arrive at interface **300**, a user **107** may have previously navigated the portal or other interface provided by system **100** to input report parameters selecting the parameters necessary to arrive at the reports given in sections **301** and **303** or otherwise select these reports. In some embodiments, these reports may be pre-generated and a user **107** need only select from a list of pre-generated reports.

[**0086**] Interface **300** also illustrates certain features whereby users **107** may further direct data manipulation and report generation such as, for example: drop down menu **305**, wherein the communities included in section **301** may be selected; buttons **307** and **309**, wherein display of different data reports may be selected; button **311** wherein the underlying data of the graph of section **301** may be viewed; text input boxes **313** and **315**, wherein upper and lower thresholds for patient distress events displayed in section **303** may be input; text input box **317**, wherein the date for the patient distress event data displayed in section **303** may be input; hyperlinks **319** and **321** to toggle through dates for section **303**, and differential indicators **323**, whereby apartments falling in categories defined by the upper and lower thresholds may be differentially indicated. In some embodiments, the differential indicators or other elements of graphical user interfaces supported by the invention may utilize differential shading, color, or other differential indication method. Other input and selection features may be used with interfaces of the invention.

[**0087**] Throughout the figures of this document, differential indicators may be represented by shading, fill, textured elements, or other differential indication (see e.g., differential fill on differential indicators **323** of FIG. **3**). Additionally, throughout the figures of this document, dates may be indicated using a month/day/year format wherein the four digits of the year are represented by asterisks (e.g., 9/5/**** in text input box **317** of FIG. **3**, which represents September 5, of a particular year). The asterisks are not meant to represent wildcard characters, but are meant as placeholders for a particular year.

[**0088**] In some embodiments, a user **107** may toggle, click, or otherwise navigate between the different interfaces of the invention provided by system **100**.

[**0089**] The interfaces enabled by the portal of enterprise management application **101** may include additional report types, graph types, query results, or other display of data. For

example, FIG. **4** illustrates an interface **400**, which is an example of a graphical user interface according to an embodiment of the invention. Interface **400** includes a section **401**, which comprises a graph depicting average response times to patient distress alarm events, by apartment, for community **1**. Interface **400** also includes a section **403**, which comprises a table of the top **10** patient distress alarm events for a certain date, by apartment, for community **1**.

[**0090**] FIG. **5** illustrates an interface **500**, which is an example of a graphical user interface according to an embodiment of the invention. Interface **500** includes a section **501**, which comprises a graph depicting slowest average patient distress event response times by apartment for community **2**. Interface **500** also includes a section **503**, which comprises a table of the top **10** patient distress alarm events, by apartment, for community **2** on a certain date.

[**0091**] FIG. **6** illustrates an interface **600**, which is an example of a graphical user interface according to an embodiment of the invention. Interface **600** includes a section **601**, which comprises a graph depicting the top patient call volume days of the current month for community **1**. Interface **600** also includes a section **603**, which comprises a table of the top **10** patient calls, by apartment, for community **1** in a certain month. In some instances, a patient call may differ from a patient distress event. For instance, a patient call may include a call for a nurse or other medical staff member to attend to a non-urgent matter, while a distress event may include use of an “emergency button,” such as an emergency alert pendent, or other indication of an emergency situation.

[**0092**] FIG. **7** illustrates an interface **700**, which is an example of a graphical user interface according to an embodiment of the invention. Interface **700** includes a section **701**, which comprises a graph depicting the top patient call volume variances by apartment for community **2**. Interface **700** also includes a section **703**, which comprises a table of the top **10** patient calls, by apartment, for community **2** in a certain month.

[**0093**] Other types of reports, query results, or data displays may also be used by the invention. FIG. **8** illustrates an interface **800**, which is another example of a graphical user interface according to an embodiment of the invention. Interface **800** illustrates a section **801** which is a detailed data report with filtering capabilities that reflects patient alarm data, including: the date of an alarm, the apartment where the alarm originated, the alarm type, and the response time. Other reports displaying other data may be used. As described above, the interfaces of the invention enable various data selection and filtering capabilities wherein a user **107** may further provide report parameters or otherwise specify the content, type, and manner of data to be displayed by the interfaces of the invention. For example, a user **107** may have arrived at interface **800** by previously indicating report, query, or other parameters instructing enterprise management application **101** to display data regarding patient distress alarm response times. Once a user **107** arrives at interface **800**, the user may use drop down input regions **803-809** to filter the patient alarm data by, for example, community, apartment, alarm type, and date. Other filtering parameters may also be available for use.

[**0094**] FIGS. **3-8** illustrate examples of interfaces displaying various types of reports enabled by system **100**. In some embodiments, system **100** may enable a “dashboard” interface that provides a plurality of information or reports (e.g., graphs, charts, lists, or other reports). FIG. **9** illustrates an

interface **900**, which is an example of a graphical user interface that provides a dashboard view of data regarding assisted living facilities. Interface **900** may include a plurality of sections (e.g., sections **901**, **903**, **905**, and **907** or other sections) that may provide reports or information regarding assisted living facilities **105** such as, for example, average patient call or event response times for various buildings in one or more communities, top patient call or event volume dates for a certain period of time (e.g., for a certain month), a listing of response times for events that exceed a certain threshold response time, a listing of apartments whose total number of calls and/or events exceed a certain threshold of events for a single day, and/or other reports or information, including any of the reports or information discussed in any of the figures herein. As such, the dashboard interface enables a user **107** to select multiple reports or information sets and view those reports or information sets on a single interface.

[**0095**] In some embodiments, a “dashboard” interface (e.g., interface **900**) may be a homepage interface for a user **107** of system **100**. For example, when a user **107** accesses the portal provided by system **100** and enters any identification and/or security information required for access (e.g., username, password, or other information), the user may be presented with a “dashboard” interface. In some embodiments, the dashboard homepage interface may include a set of “standard” reports that are presented to the user **107**. In some embodiments, a user **107** may customize the type of reports included in their dashboard homepage and/or may customize the information displayed in those reports.

[**0096**] In some embodiments, system **100** may enable users **107** to manage their accounts and/or access to system **100**. As disclosed herein, a user account module may enable one or more user accounts to be maintained on system **100**. Each such user account may include or be associated with information relating to a specific user such as, for example, user name, password, email address, home address, position or title, phone numbers, fax numbers, permission information (e.g., for determining the level of access the user has to system **100**), and/or other information. FIG. **10** illustrates an interface **1000**, which is an example of a graphical user interface according to an embodiment of the invention, wherein a user **107** may manage his or her security information (e.g., password, associated email address or other security information) and/or other information associated with his or her user account. For example, interface **1000** may include a text entry area wherein a user **107** can specify the email address associated with the user accounts. The email address associated with a user account may be used for one or more purposes such as, for example, a destination where messages, alerts, or tasks from system **100** may be sent. In some embodiments, if a user forgets his or her password, the new password may be sent to the associated email address. In some embodiments, the email address may be used as a username. The email address or other content information associated with the user account may have other uses. Interface **1000** may also include text entry areas wherein an old password may be entered, a new password may be entered and confirmed, security options relating to how the password is to be recovered when lost/forgotten, an answer to a question that serves as a key to a lost/forgotten password, and/or other elements.

[**0097**] System **100** may enable other interfaces wherein users **107** may manage their user account information. FIG. **11** illustrates an interface **1100**, which is an example of a graphical user interface wherein a user **107** may manage

additional user account information. For example, interface **1100** may enable users to enter or edit their name, company affiliation, title, address, phone, fax or cell number (or other contact info), or other information.

[**0098**] System **100** may also enable certain users **107** (e.g., an upper level manager) to manage the user accounts and/or access of other users **107** (e.g., facility managers or personnel). FIG. **12** illustrates an interface **1200**, which is an example of an interface wherein a first user can manage the accounts of one or more additional users. In some embodiments, interface **1200** includes a section **1201**, wherein various individual user accounts may be listed and selected for editing or other management. Section **1201** illustrates that there may exist several accounts having the name of the same person associated therewith. Having multiple accounts associated with the same person illustrates how different levels of permissions may be allocated to a single person. For example, a certain user **107** may have access to one or multiple views for different buildings or sets thereof or different communities or sets thereof. These different permissions may be allocated via multiple accounts to the same person. Other permission schemes may be employed, including schemes wherein a single account includes all of the permission information for a single individual user.

[**0099**] In some embodiments, interface **1200** includes a section **1203**, wherein individual selected user accounts can be edited. For example, use of the “is approved” checkbox illustrated in section **1203** may enable a certain account to be turned off or on. This may be especially useful in situations where permissions are controlled using multiple accounts for the same user (e.g., selectively editing turning off permissions for a first set of buildings that the user previously had permissions to, while leaving on the user’s permissions to a second set of buildings). Furthermore, the “roles” checkboxes illustrated in section **1203** may enable definition of a user’s role. The user’s role may further aid in defining the user’s permissions or ability to manage the accounts of other users. For example, if a certain user is indicated as including an “admin” role, that user may be able to edit other user’s accounts by way of, for example, a “manage” tab available to the user via the portal of system **100**. A “communities” area of section **1203** may enable definition of one or more communities, buildings, or other areas that a user may have permissions for/access to. An “email login info” button may enable a manager of user accounts to send a user their account login info (e.g., username, password) or other account information to the user’s email address.

[**0100**] An account management interface, such as interface **1200**, may include other features or functions.

[**0101**] System **100** may also enable certain users **107** (e.g., upper level managers) to manage and/or view data regarding the one or more assisted living facilities **105** and/or one or more regions each having one or more assisted living facilities **105** therein. FIG. **13** illustrates an interface **1300**, which is an example of an interface for viewing data regarding and managing assisted living facilities **105**. In some embodiments, interface **1300** may include a section **1301**, which is a list of the assisted living facilities **105** available for management. In some embodiments, a user **107** may select an assisted living facility listed in section **1301** for management. Certain data regarding the selected assisted living facility **105** may be viewed and/or edited in a section **1303**. In some embodiments the information regarding with a selected assisted living facility that may be viewed and/or edited via section **1303** may

include the ID number of the selected facility, the facility name, the database wherein data regarding the selected facility is stored, (e.g., information from different assisted living facilities **105** may be stored in different sections of database **103** or different individual databases comprising database **103**), and/or other information. In some embodiments, the information regarding the selected assisted living facility may be edited using one or more text entry boxes provided in section **1303**. In some embodiments, other information associated with assisted living facilities **105** may be viewed and/or edited in an assisted living facility management interface.

[0102] FIG. **14** illustrates an interface **1400**, which is an example of an interface for viewing and/or managing assisted living facility regions, each region having one or more assisted living facilities **105** therein. In some embodiments, interface **1400** may include a section **1401**, which is a list of assisted living facility regions available for management via system **100**. In some embodiments, a user **107** may select an assisted living facility region from the list in section **1401** for management. Interface **1400** also includes a section **1403**, wherein information associated with assisted living facility regions may be viewed and/or edited. Information associated with assisted living facility regions may include a region id number, a region name, the assisted living facilities **105** (e.g., communities) associated with the region, and/or other information. In some embodiments, interface **1400** may include one or more text entry boxes wherein edits to some or all of the information associated with assisted living facility regions may be made.

[0103] As described above, users **107** may access system **100** and database using mobile or wireless user devices. As such, one or more modules **111a-n** (e.g., an interface module) of enterprise management application **101** may enable the portal of system **100** (e.g., web portal) to present graphical user interfaces compatible with mobile devices. FIG. **15A** illustrates a wireless mobile user device **1501** which may display an interface of enterprise management application **101**. Other mobile user devices may be used. FIG. **15B** illustrates an interface **1503**, which is an example of a mobile graphical user interface that may be displayed on a mobile user device.

[0104] In some embodiments, enterprise management application **101** may enable alerts to be sent to one or more users **107**. For example, in some embodiments, alerts may be sent to high level business managers to keep them apprised of the operations of one or more assisted living facilities **105** or for other purposes. In another example, alerts may be sent to facility managers or health care staff on site at an assisted living **105** facility to keep them apprised of conditions at the assisted living facility, to assign tasks to certain personnel, to update tasks assigned to personnel, or for other purposes. Alerts may be sent to other users **107** for other purposes.

[0105] One or more modules **111a-n** (e.g., an alert module) of enterprise management application **101** may support generating alerts for one or more users **107**. Alerts may be automatically generated or generated on demand (manual generation). In some embodiments, automatically generated alerts may be sent to a specific user **107** according an alert profile associated with the specific user. In some embodiments, the alert profile may be part of an individual user's user account. For example, in some embodiments, an alert profile for a user **107** may include information as to the content of an alert (e.g., content preferences), the format of an alert (e.g., format preferences), the delivery method of an alert (e.g., delivery preferences),

the timing of an alert (e.g., timing preferences), or other preferences. Content preferences may specify the specific information contained within an alert (e.g., top patient distress alarm response time by apartment for community **1**). Delivery preferences may specify the format and/or delivery method by which an alert is delivered, for example, via email, phone, text message, instant message, fax, or other delivery method. Timing preferences may include a schedule or set of triggering conditions upon which alerts will be delivered (e.g., alerts sent every hour or alerts sent when average patient distress response time in community **1** exceeds a threshold). Other preferences dictating other aspects of alerts may be used.

[0106] In some embodiments, specific preferences may be tied to specific triggering conditions. For example, when a first set of triggering conditions is met, an alert may be sent according to a first set of content preferences. When a second set of triggering conditions is met, an alert may be sent according to a second set of content preferences. Other preferences (e.g., delivery or other preferences) may be tied to specific triggering conditions.

[0107] When a condition matching the triggering conditions of the alert profile of a user **107** is detected by enterprise management system **101** (e.g., an average response time for a certain community rises above a predetermined threshold), the alert module may generate an alert according to the user's content preferences (e.g., the content preferences are used similar to report parameters, wherein a report or query module applies the content preferences against database **103** to generate the content for the alert). The alert may then be sent to the user **107** according to the user's alert profile (e.g., in the format and by delivery method specified by the delivery preferences, and/or according to other preferences).

[0108] In some embodiments, system **100** (e.g., alert module of enterprise management application **101**) may support creation, storage, and communication regarding one or more tasks. A task may be a type of alert and may include a set of instructions other set of information regarding one or more assisted living communities **105**. For example, FIG. **16A** illustrates an interface **1600**, which is an example of a task alert management interface according to an embodiment of the invention, wherein task alerts or other alerts may be managed. Interface **1600** includes a section **1601**, which lists various tasks that exist on system **100**. Section **1601** or other task list may include information regarding each of the tasks listed such as, for example, a task ID, an event date (e.g., when the event was recorded by a monitoring device **113** of system **100**—for example, when a patient has fallen and called for help), an assigned date (e.g., a date when the task was assigned or communicated to the personnel responsible for performing, attending to, responding to, overseeing, or managing completion of the task), a task type (e.g., a “trend” task type may indicate that the task is a notification of a certain trend in assisted living facility data; a “keydriver” task type may include a call volume per room task alert), task status (e.g., has the task be completed or attended to), the one or more assisted living facilities **105** (e.g., communities) associated with the task, a hyperlink or other pointer enabling a user **107** to view a listed task, edit a listed task, assign a listed task, send an alert relating to a listed task, a differential indicator of the task's importance or urgency (e.g., high alert items such as, for example, a patient distress call or indication of dangerous health conditions may be indicated with a red colored differential indicator, while lower alert indicators

such as, for example, an alert that indicates that a certain community is running low on bedpans may be indicated with a yellow differential indicator), or other list features.

[0109] FIG. 16B illustrates an interface 1620, which is an example of a detailed task management interface according to an embodiment of the invention. To arrive at detailed task management interface 1621, a user 107 may, for example, select a task from a task list of a task management interface (e.g., a user may click on a hyperlink to a task listed in section 1601 of interface 1600). Interface 1620 may include a section 1621, which may provide information relating to a specific task, such as, for example, a task ID, a task status, one or more personnel assigned to the task, an email address associated with the task, a date and/or time when the task was assigned, one or more assisted living facilities 105 associated with the task, one or more apartments or specific subsections of an assisted living facility 105 associated with the task, an event date, a response time associated with the task (e.g., a time from when the task was assigned until the task is completed), a call volume (e.g., the number of patient distress calls associated with the task), a specific message, instruction, or other piece of information associated with the task (e.g., information conveying instructions or other information via text, audio, video or other format), or other information. Interface 1620 may also include a section or a link to an interface wherein a user 107 may create, edit (including editing the information presented in sections 1601, 1621, or other sections or interfaces), and/or delete one or more tasks.

[0110] The alert features disclosed above, may be utilized deliver communications regarding one or more tasks. For example, the alert features disclosed herein may be used to send an email or other communication that assigns and/or notifies appropriate personnel associated with a task. FIG. 16C illustrates an interface 1640, which is an example of an interface according to an embodiment of the invention that may be utilized to manually send alerts relating to a task to users 107. FIG. 16C also illustrates a task alert 1641 that displays the top ten high patient distress alarm events, by apartment, on a certain day at community 1. Interface 1641 includes a text input region 1643, wherein a user may specify a recipient email address for a recipient user for alert 1641. Other interfaces supported by enterprise management application 101 may enable alert 1641 to be sent via other delivery methods, to multiple recipients, or other options. Interface 1640 may also include a send button 1645, which, when actuated, may send alert 1641 to the recipient user.

[0111] Using the alert/task interfaces provided by system 100 a first user 107 may create, edit, assign, and communicate tasks to one or more second users 107. For example, a first user (e.g., a corporate manager) may be informed, through system 100 or otherwise) that a problematic condition (e.g., slow patient distress alarm response time) exists at a certain community. The first user may utilize system 100 to send a task alert to a second user (e.g., a local community manager) detailing the problematic condition and/or instructing the second manager to remedy the problematic condition. In some embodiments, this may be done using an on-demand alert. In some embodiments, this may be done using an automatically generated alert.

[0112] In some embodiments, the invention may include a computer/processor-readable medium that includes computer/processor-readable code that causes a processor, computer, or other computer system or part thereof to acquire and manipulate data associated with one or more assisted living

facilities and otherwise enable monitoring and management of the one or more facilities. As such, the computer/processor readable code includes code for performing some or all of the features and functions described herein such as, for example, gathering data from monitoring devices and their associated systems, transmitting the data across a network, receiving the data, examining/processing the data, storing the data in a database, receiving data manipulation instructions (e.g., report parameters, query parameters, alert parameters, or other instructions), manipulating the data, enabling one or more interfaces for the receipt of data and/or instructions, enabling one or more interfaces for the presentation of data, enabling the production and transmittal of alerts or tasks, and/or for enabling other features or functions of the invention.

[0113] While the invention has been described with reference to the certain illustrated embodiments, the words that have been used herein are words of description, rather than words of limitation. Changes may be made, within the purview of the associated claims, without departing from the scope and spirit of the invention in its aspects. Although the invention has been described herein with reference to particular structures, acts, and materials, the invention is not to be limited to the particulars disclosed, but rather can be embodied in a wide variety of forms, some of which may be quite different from those of the disclosed embodiments, and extends to all equivalent structures, acts, and materials, such as are within the scope of the associated claims.

What is claimed is:

1. A system for acquiring and monitoring operational data in assisted living facilities, the system comprising:
 - a plurality of event monitoring devices that gather data associated with at least one assisted living facility;
 - a database that receives, over a network, the data associated with the at least one assisted living facility from the plurality of event monitoring devices;
 - an enterprise management application that generates one or more reports regarding the at least one assisted living facility using the data associated with the at least one assisted living facility; and
 - a graphical user interface that displays the one or more reports to one or more user devices.
2. The system of claim 1, wherein the data associated with the at least one assisted living facility includes one or more of patient distress event data, patient distress event response data, employee time data, security system data, automatic entryway data, and inventory data.
3. The system of claim 1, wherein the plurality of event monitoring devices include one or more of patient medical alert necklaces, medical monitoring devices, staff event response devices, employee time entry systems, facility security systems, and automatic entryway systems.
4. The system of claim 1, wherein the network includes the Internet.
5. The system of claim 4, wherein the graphical user interface is accessible over the network via a web portal.
6. The system of claim 1, wherein the network includes a wireless telecommunications network.
7. The system of claim 1, wherein the graphical user interface is an alert sent to the one or more user devices over the network.
8. The system of claim 7, wherein the alert includes a task to be performed.

9. The system of claim 7, wherein the alert is automatically generated.

10. The system of claim 7 wherein the alert is generated on demand.

11. The system of claim 1, wherein the one or more user devices include one or more of a server, a desktop computer, a laptop computer, a dumb terminal, a handheld computer, a personal digital assistant, and a cell phone.

12. A method for acquiring and monitoring operational data in assisted living facilities, the method comprising:

receiving, over a network, data associated with at least one assisted living facility from a plurality of event monitoring devices;

storing the data associated with the at least one assisted living facility in a database;

generating one or more reports regarding the at least one assisted living facility from the stored data associated with the at least one assisted living facility;

presenting at least one of the one or more reports to one or more user devices via a graphical user interface.

13. The method of claim 12, wherein the data associated with the at least one assisted living facility includes one or more of patient distress event data, patient distress event response data, employee time data, security system data, automatic entryway data, and inventory data.

14. The method of claim 12, wherein the plurality of event monitoring devices include one or more of patient medical alert necklaces, medical monitoring devices, staff event response devices, employee time entry systems, facility security systems, and automatic entryway systems.

15. The method of claim 12, wherein the network includes the Internet.

16. The method of claim 15, wherein the graphical user interface is accessible over the network via a web portal.

17. The method of claim 1, wherein the network includes a wireless telecommunications network.

18. The method of claim 1, wherein the graphical user interface is an alert, and wherein presenting at least one of the one or more reports further comprises sending the alert to the one or more user devices over the network.

19. The method of claim 18, wherein the alert includes a task to be performed.

20. The method of claim 18, wherein the alert is automatically generated.

21. The method of claim 18, wherein the alert is generated on demand.

22. The method of claim 12, wherein the one or more user devices include one or more of a server, a desktop computer, a laptop computer, a dumb terminal, a handheld computer, a personal digital assistant, and a cell phone.

23. A processor readable medium comprising processor readable code that causes a processor to acquire and monitor operational data in assisted living facilities, the processor readable medium comprising:

receiving code that causes a processor to receive, over a network, data associated with at least one assisted living facility from a plurality of event monitoring devices;

storing code that causes a processor to store the data associated with the at least one assisted living facility in a database;

generating code that causes a processor to generate one or more reports regarding the at least one assisted living facility from the stored data associated with the at least one assisted living facility;

presenting code that causes a processor to present at least one of the one or more reports to one or more user devices via a graphical user interface.

24. The processor readable code of claim 23, wherein the data associated with the at least one assisted living facility includes one or more of patient distress event data, patient distress event response data, employee time data, security system data, automatic entryway data, and inventory data.

25. The processor readable code of claim 23, wherein the plurality of event monitoring devices include one or more of patient medical alert necklaces, medical monitoring devices, staff event response devices, employee time entry systems, facility security systems, and automatic entryway systems.

26. The processor readable code of claim 23, wherein the network includes the Internet.

27. The processor readable code of claim 26, wherein the graphical user interface is accessible over the network via a web portal.

28. The processor readable code of claim 23, wherein the network includes a wireless telecommunications network.

29. The processor readable code of claim 23, wherein the graphical user interface is an alert, and wherein the presenting code that causes a processor to present at least one of the one or more reports further comprises sending code that causes a processor to send the alert to the one or more user devices over the network.

30. The processor readable code of claim 29, wherein the alert includes a task to be performed.

31. The processor readable code of claim 29, wherein the alert is automatically generated.

32. The processor readable code of claim 29, wherein the alert is generated on demand.

33. The processor readable code of claim 23, wherein the one or more user devices include one or more of a server, a desktop computer, a laptop computer, a dumb terminal, a handheld computer, a personal digital assistant, and a cell phone.

34. A system for acquiring and monitoring operational data in assisted living facilities, comprising:

a plurality of assisted living facilities at different locations;

a plurality of patient monitors for monitoring patients at the facilities, the plurality of patient monitors each capable of generating an alert signal indicative of an event;

a central station including a processor for receiving the alert signal; and

a response switch for generating a response signal upon activation thereof, the response signal indicating that the event has been attended to,

wherein the central station processor determines a response time between the alert signal and the response signal and maintains a central database of response times at the different facilities.

35. The system of claim 34, wherein one or more of the plurality of patient monitors is each associated with a particular apartment within one of the facilities.

36. The system of claim 34, wherein one or more of the plurality of patient monitors is associated with a particular patient.

37. The system of claim 34, wherein the plurality of patient monitors include one or more of patient alert pendants, nurse call buttons, heart rate monitors, respiration monitors, blood pressure monitors, temperature monitors, and blood-gas monitors.

38. The system of claim **34**, wherein the central station processor generates one or more graphical user interfaces displaying response time data using the central database of response times at the different facilities.

39. The system of claim **38**, further comprising one or more user devices that access the one or more graphical user interfaces over a network.

40. The system of claim **39** wherein the network includes the Internet.

41. The system of claim **39** wherein the network includes a wireless network.

42. The system of claim **39**, wherein the one or more user devices include one or more of a server, a desktop computer, a laptop computer, a dumb terminal, a handheld computer, a personal digital assistant, and a cell phone.

43. The system of claim **38**, wherein at least one of the one or more graphical user interfaces includes a graph displaying average event response times for one or more of the plurality of assisted living facilities.

44. The system of claim **43**, wherein the at least one of the one or more graphical user interfaces includes a user input region for selecting the assisted living facilities displayed in the graph.

45. The system of claim **38**, wherein at least one of the one or more graphical user interfaces includes a table displaying total events for each of one or more patient apartments on a selected date in one of the plurality of assisted living facilities.

46. The system of claim **45**, wherein the at least one of the one or more graphical user interfaces further includes a date input region for user input of the selected date.

47. The system of claim **45**, wherein the at least one of the one or more graphical user interfaces further includes one or more threshold input regions for user input of one or more event thresholds.

48. The system of claim **47**, wherein the one or more threshold input regions include an upper event threshold input region and a lower event threshold input region.

49. The system of claim **48**, wherein apartments falling above the upper event threshold are differentially indicated from apartments not falling above the upper event indicator, wherein apartments falling below the lower event threshold are differentially indicated from apartments not falling below the lower event threshold, and wherein apartments falling between the upper event threshold and the lower event threshold are differentially indicated from apartments not falling between the upper event threshold and the lower event threshold.

50. The system of claim **45**, wherein the at least one of the one or more graphical user interfaces further includes one or more hyperlinks to one or more charts displaying total events for one or more patient apartments on a different selected date in the one of the plurality of assisted living facilities.

51. The system of claim **38**, wherein at least one of the one or more graphical user interfaces includes a graph displaying average overall event response times by apartment for one of the plurality of assisted living facilities.

52. The system of claim **51**, wherein the at least one of the one or more graphical user interfaces includes a user input region for selecting the assisted living facility displayed in the graph.

53. The system of claim **38**, wherein at least one of the one or more graphical user interfaces includes a graph displaying

average event response times by apartment for one of the plurality of assisted living facilities.

54. The system of claim **53**, wherein the at least one of the one or more graphical user interfaces includes a user input region for selecting the assisted living facility displayed in the graph.

55. The system of claim **38**, wherein at least one of the one or more graphical user interfaces includes a graph displaying event volume by day during a predetermined period of time for one of the plurality of assisted living facilities.

56. The system of claim **55**, wherein the at least one of the one or more graphical user interfaces includes a user input region for selecting the assisted living facility displayed in the graph.

57. The system of claim **38**, wherein at least one of the one or more graphical user interfaces includes a graph displaying event volume variance by apartment for one of the plurality of assisted living facilities.

58. The system of claim **57**, wherein the at least one of the one or more graphical user interfaces includes a user input region for selecting the assisted living facility displayed in the graph.

59. The system of claim **38**, wherein at least one of the one or more graphical user interfaces includes a chart displaying events for one or more of the plurality of assisted living facilities.

60. The system of claim **59**, wherein the chart displays one or more of a date of the event, an apartment associated with the event, an event type, and a response time for the event.

61. The system of claim **59**, wherein the at least one of the one or more graphical user interfaces includes one or more of a facility region for user selection of the one or more of the plurality of assisted living facilities, an apartment input region for user selection of apartments with which the displayed events are associated, an alarm type input for user selection of an event type with which the displayed events are associated, and a date selection input for user selection of dates with which the displayed events are associated.

62. The system of claim **38** wherein at least one of the one or more graphical user interfaces include a graphical user interface for display on a mobile user device.

63. The system of claim **38**, wherein at least one of the one or more graphical user interfaces includes a alert recipient input region for user input of an destination address for a recipient of an alert.

64. The system of claim **63**, wherein the at least one of the one or more graphical user interfaces includes a send alert input region for manual user initiation of transmission of the alert to the recipient.

65. The system of claim **38**, wherein at least one of the one or more graphical user interfaces include a graphical user interface that displays one or more task alerts, at least one of the task alerts including information from the central database of response times.

66. The system of claim **65**, wherein the at least one of the one or more graphical user interfaces includes a section for editing information associated with the at least one of the task alerts.

67. The system of claim **66**, wherein information associated with the at least one of the task alerts includes one or more of a user associated with the at least one of the task alerts and an email address of the user.

* * * * *

专利名称(译)	设施管理系统		
公开(公告)号	US20080242945A1	公开(公告)日	2008-10-02
申请号	US11/729848	申请日	2007-03-30
[标]申请(专利权)人(译)	STANLEY安全解决方案		
申请(专利权)人(译)	STANLEY安全解决方案, INC.		
当前申请(专利权)人(译)	STANLEY安全解决方案, INC.		
[标]发明人	GUGLIOTTI NICOLA TYLER HAROLD TODD		
发明人	GUGLIOTTI, NICOLA TYLER, HAROLD TODD		
IPC分类号	A61B5/00		
CPC分类号	A61B5/02055 A61B5/08 G05B15/02 G06F19/322 G06F19/327 G06F19/3406 G06F19/3418 G06F19/3487 G07C3/00 A61B5/0022 G16H10/60 G16H15/00 G16H40/20 G16H40/63 G16H40/67		
外部链接	Espacenet USPTO		

摘要(译)

本发明提供了用于获取, 操纵和监视与一个或多个辅助生活设施相关联的数据的系统和方法。本发明包括利用一个或多个监测设备来收集关于至少一个辅助生活设施的数据。然后, 数据通过网络传输并保存在数据库中。然后, 企业管理应用程序对数据进行操作, 以根据由一个或多个用户指定的参数和指令来操纵和显示数据。一个或多个用户可以使用该数据来监视和管理一个或多个辅助生活设施。

