



(19) **United States**

(12) **Patent Application Publication**
Debreczeny

(10) **Pub. No.: US 2008/0081972 A1**

(43) **Pub. Date: Apr. 3, 2008**

(54) **SYMMETRIC LED ARRAY FOR PULSE OXIMETRY**

Publication Classification

(75) Inventor: **Martin P. Debreczeny**, Danville, CA (US)

(51) **Int. Cl.**
A61B 5/00 (2006.01)

(52) **U.S. Cl.** **600/323; 600/310**

Correspondence Address:
Covidien
IP Counsel - Respiratory & Monitoring Solutions
60 Middletown Avenue
North Haven, CT 06473

(57) **ABSTRACT**

There is provided a sensor for pulse oximeter systems. The sensor comprises a first source of electromagnetic radiation configured to operate at a first wavelength, a second source of electromagnetic radiation configured to operate at a second wavelength, and a third source of electromagnetic radiation configured to operate at a third wavelength. The emission spectra of the first and third sources of electromagnetic radiation overlap at their half power level or greater and correspond to a center wavelength in the range of 650 to 670 nm.

(73) Assignee: **Nellcor Puritan Bennett Incorporated**

(21) Appl. No.: **11/541,287**

(22) Filed: **Sep. 29, 2006**

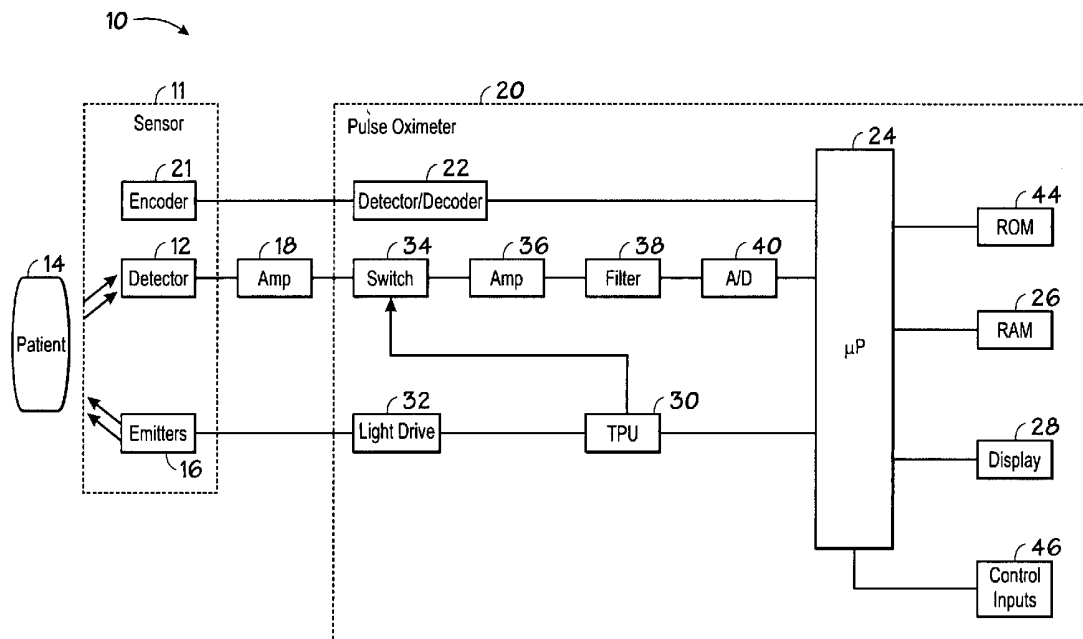

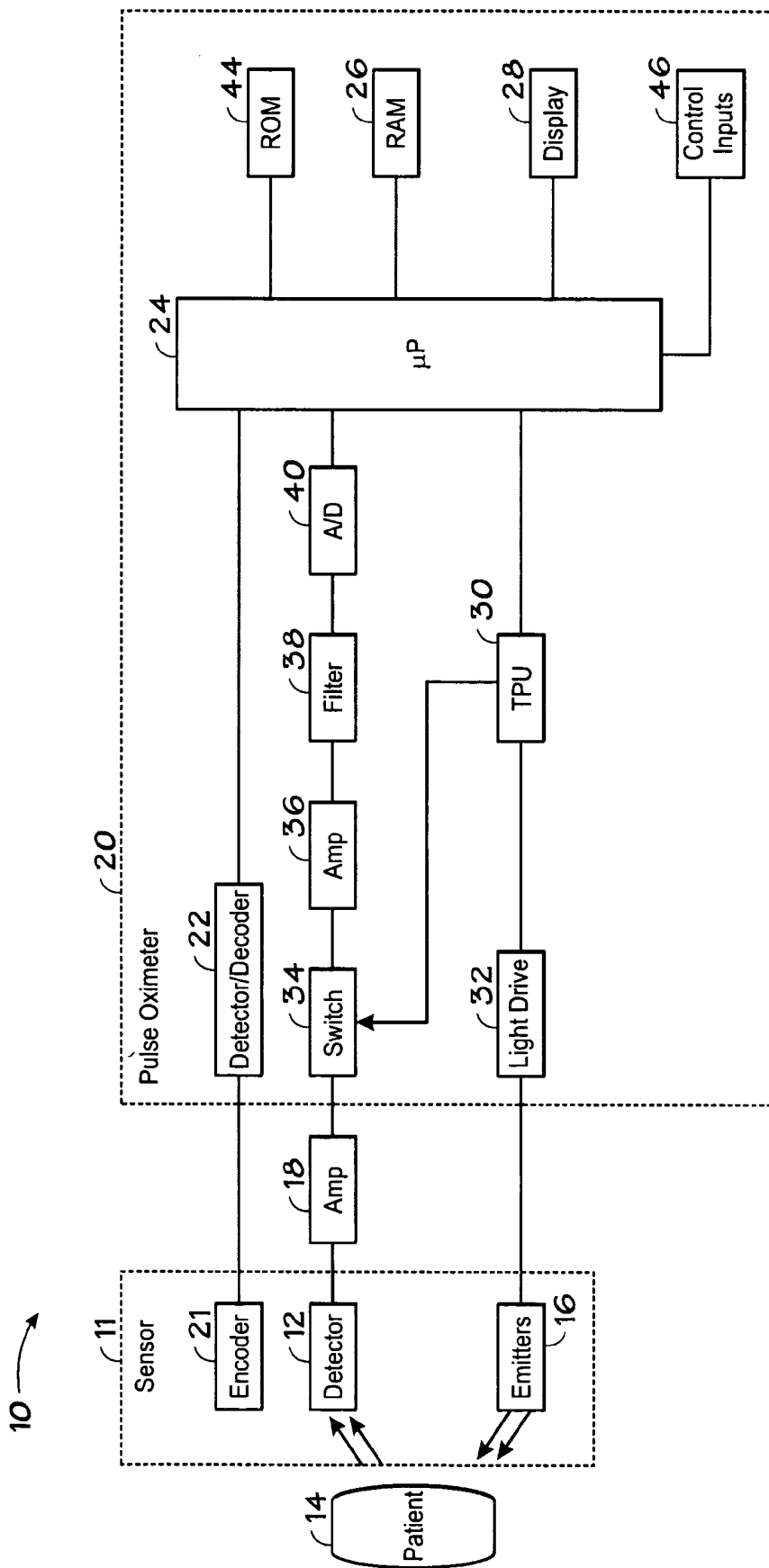

FIG. 1

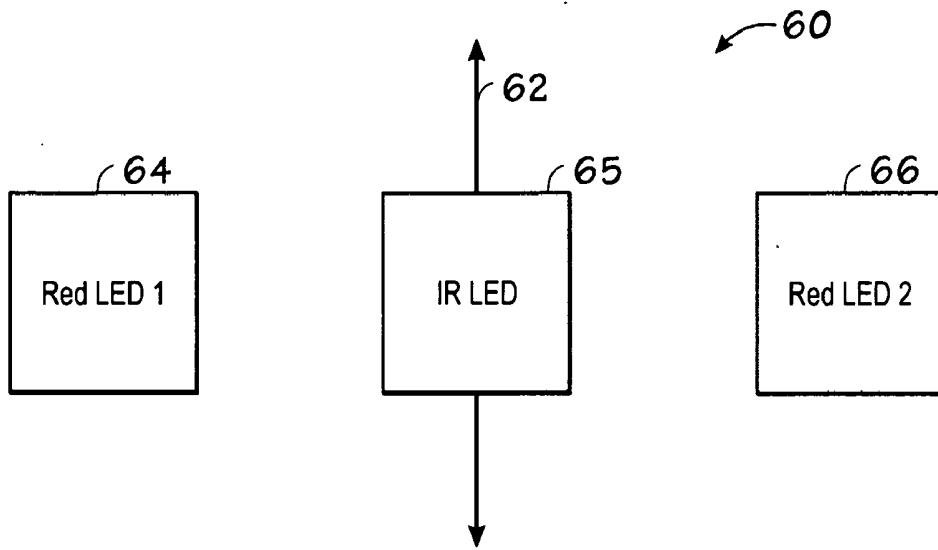

FIG. 2

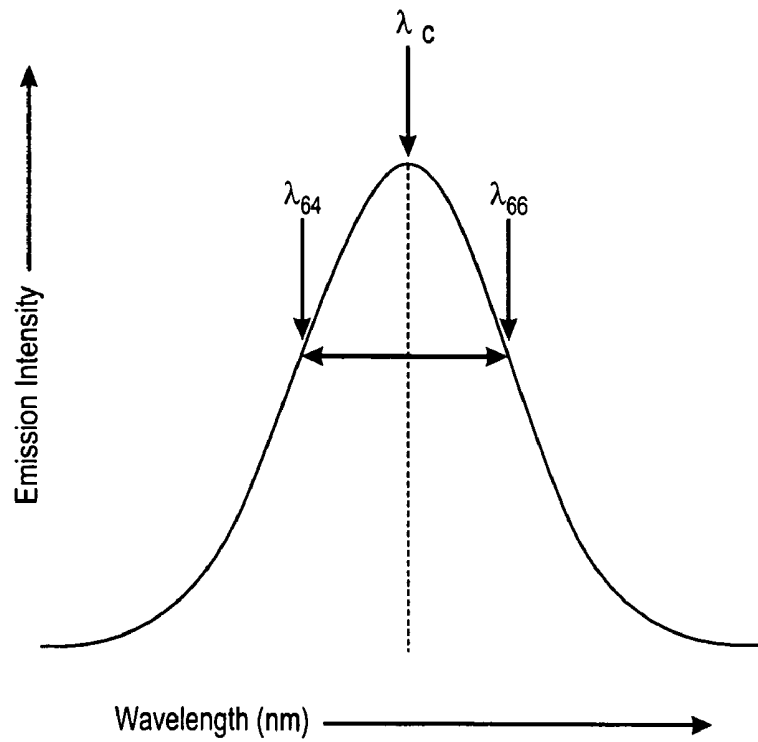

FIG. 3

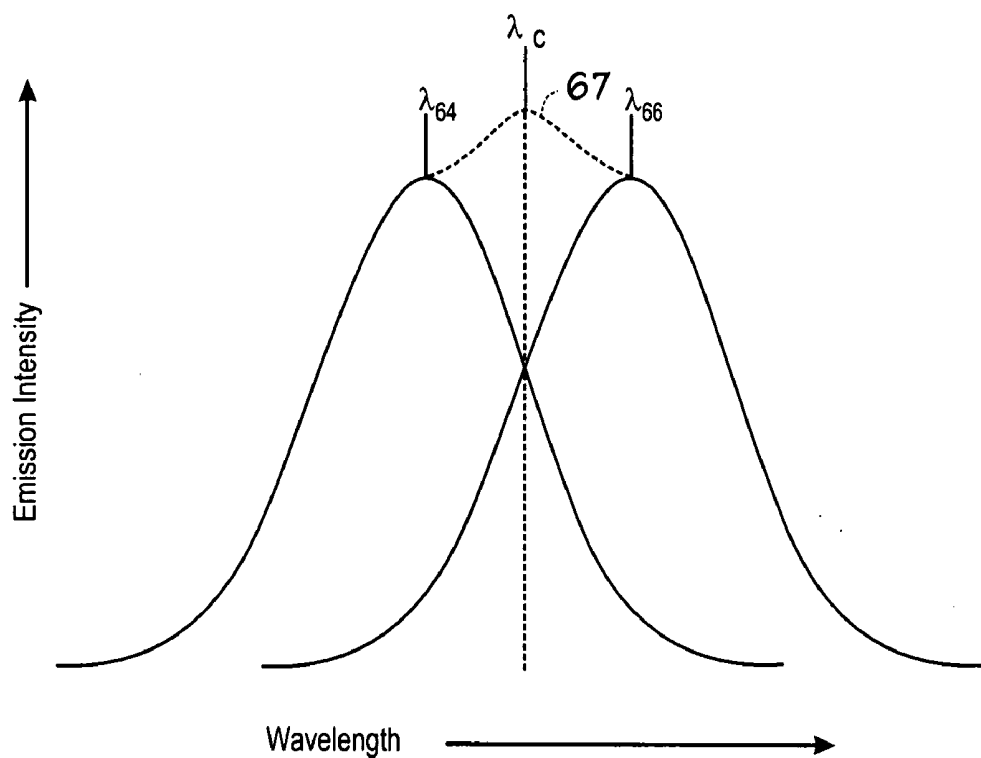

FIG. 4

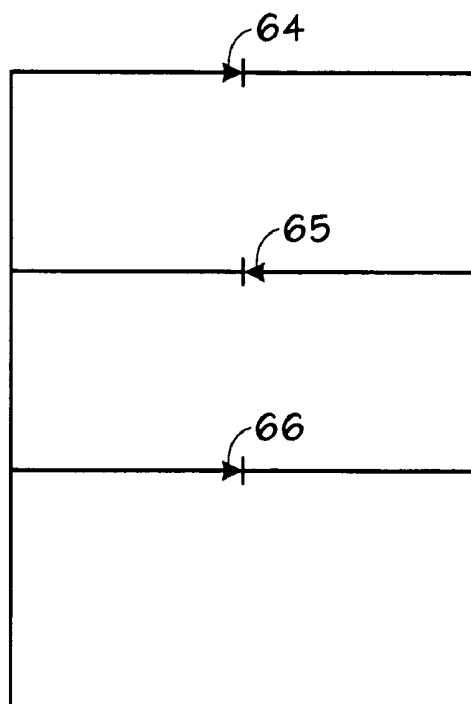

FIG. 5

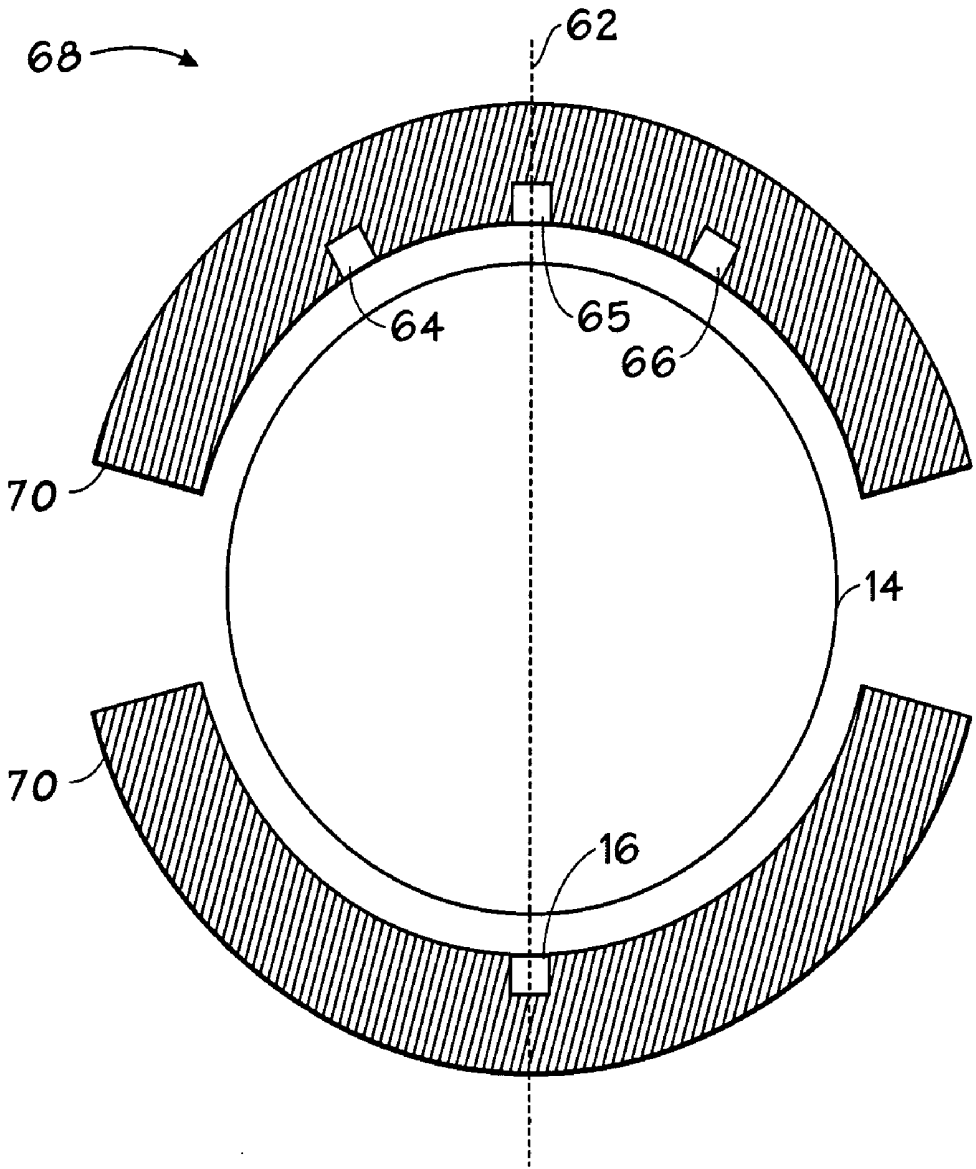

FIG. 6

SYMMETRIC LED ARRAY FOR PULSE OXIMETRY

BACKGROUND

[0001] 1. Field of Invention

[0002] The present invention relates generally to medical devices and, more particularly, to sensors used for sensing physiological parameters of a patient.

[0003] 2. Description of the Related Art

[0004] This section is intended to introduce the reader to various aspects of art that may be related to various aspects of the present invention, which are described and/or claimed below. This discussion is believed to be helpful in providing the reader with background information to facilitate a better understanding of the various aspects of the present invention. Accordingly, it should be understood that these statements are to be read in this light, and not as admissions of prior art.

[0005] In the field of medicine, doctors often desire to monitor certain physiological characteristics of their patients. Accordingly, a wide variety of devices have been developed for monitoring many such characteristics of a patient. Such devices provide doctors and other healthcare personnel with the information they need to provide the best possible healthcare for their patients. As a result, such monitoring devices have become an indispensable part of modern medicine.

[0006] One technique for monitoring certain physiological characteristics of a patient is commonly referred to as pulse oximetry, and the devices built based upon pulse oximetry techniques are commonly referred to as pulse oximeters. Pulse oximetry may be used to measure various blood flow characteristics, such as the blood oxygen saturation of hemoglobin in arterial blood, the volume of individual blood pulsations supplying the tissue, and/or the rate of blood pulsations corresponding to each heart beat of a patient. In fact, the "pulse" in pulse oximetry refers to the time varying amount of arterial blood in the tissue during each cardiac cycle.

[0007] Pulse oximeters typically utilize a non-invasive sensor that transmits or reflects electromagnetic radiation, such as light, through a patient's tissue and that photoelectrically detects the absorption and scattering of the transmitted or reflected light in such tissue. One or more of the above physiological characteristics may then be calculated based upon the amount of light absorbed and scattered. More specifically, the light passed through or reflected from the tissue is typically selected to be of one or more wavelengths that may be absorbed and scattered by the blood in an amount correlative to the amount of blood constituent present in the tissue. The measured amount of light absorbed and scattered may then be used to estimate the amount of blood constituent in the tissue using various algorithms.

[0008] Certain events can create error in these measurements. For example, pulse oximetry measurements may be sensitive to movement of the sensor relative to the patient's tissue, and various types of motion may cause artifacts that may obscure the blood constituent signal. Specifically, motion artifacts may be caused by moving a sensor in relation to the tissue, increasing or decreasing the physical distance between emitters and detectors in a sensor, changing the angles of incidents and interfaces probed by the light,

directing the optical path through different amounts or types of tissue, and by expanding, compressing, or otherwise altering tissue near a sensor.

[0009] Pulse oximetry may utilize light sources that emit in at least two different or spectral regions, one that emits in the red region (typically about 660 nm) and one in the near infrared region (typically about 890-940 nm). Typically, LEDs are used as light sources and are held in close proximity, i.e., optically coupled, to a tissue location being probed. In the context of pulse oximetry, optical coupling refers to a relationship between the sensor and the patient, permitting the sensor to transmit light into the patient's blood profused tissue and permitting a portion of the light to return to the sensor after passing through or reflecting from within the tissue. The quality of the optical coupling of the emitters and detectors is related to the amount of light that actually enters the patient's tissue and the portion of the light received by the sensor that passes through the patient's blood profused tissue. As described earlier, motion and/or the application of excessive pressure can have the effect of changing the relative optical coupling efficiency of the light sources and the detector. Even when two LEDs are mounted side by side, motion induced changes in optical efficiency have resulted in distortions of the photoplethysmographs produced by the two LEDs. The result of poor coupling, therefore, is a decrease in the accuracy of the sensor.

[0010] Homogenizing the light sources using optical coupling devices is one way of mitigating the effect of motion-induced changes in optical efficiency on the accuracy of a pulse oximeter. Such techniques, however, generally require careful optical alignment, tend to be expensive, or reduce the optical coupling efficiency into the tissue.

[0011] Sensor-to-sensor spectral variation of light sources used for oximeter sensors may also affect a pulse oximeter's accuracy. Because hemoglobin (HbO₂ and HHb) spectra vary more rapidly as a function of wavelength at approximately 660 nm than at approximately 940 nm, the precise spectral content of the 660 nm light source is more critical. Current manufacturing processes used to produce 660 nm LEDs result in a wide distribution of spectral content, potentially necessitating modification of the calibration model according to actual spectral content of the 660 nm source, thus adding cost to the system. Alternatively, choosing only LEDs that emit in a narrow wavelength range would result in low production yields and higher sensor cost. Thus, costs are incurred either by limiting the range of wavelengths to reduce the need for calibration, or by allowing for a wider spectral content and inserting calibration models.

SUMMARY

[0012] Certain aspects commensurate in scope with the originally claimed invention are set forth below. It should be understood that these aspects are presented merely to provide the reader with a brief summary of certain forms the invention might take and, these aspects are not intended to limit the scope of the invention. Indeed, the invention may encompass a variety of aspects that may not be set forth below.

[0013] In accordance with one aspect of the present invention a sensor for pulse oximeter systems is provided. The sensor comprises a first source of electromagnetic radiation configured to operate at a first wavelength, a second source of electromagnetic radiation configured to operate at a

second wavelength and a third source of electromagnetic radiation configured to operate at a third wavelength. The first and third sources of electromagnetic radiation overlap at their half power level or greater and correspond to a center wavelength in the range of 650 to 670 nm. A photodetector is configured to receive electromagnetic radiation from blood-perfused tissue irradiated by the first, second and third sources of electromagnetic radiation.

[0014] In accordance with another aspect of the present invention there is provided a sensor comprising a first source of electromagnetic radiation configured to operate at a first wavelength, a second source of electromagnetic radiation configured to operate at a second wavelength and a third source of electromagnetic radiation configured to operate at a third wavelength. A photodetector is configured to receive electromagnetic radiation from the blood-perfused tissue, and the first and third sources of electromagnetic radiation are symmetrically disposed spatially relative to the photodetector.

[0015] In accordance with yet another aspect of the present invention a sensor comprising a first light emitting diode configured to emit radiation having a maximum intensity corresponding to wavelengths in a red region of the electromagnetic spectrum. The sensor also comprises a second LED configured to operate in the near-infrared region of the electromagnetic spectrum and a third LED configured to operate in the red region of the electromagnetic spectrum. The third LED has a maximum intensity at a wavelength greater than 650 nm and greater than the wavelength at which the first LED has a maximum. The first LED and third LED are spectrally symmetrical with respect to a center wavelength in the range 650 to 670 nm.

BRIEF DESCRIPTION OF THE DRAWINGS

[0016] Advantages of the invention may become apparent upon reading the following detailed description and upon reference to the drawings, in which:

[0017] FIG. 1 illustrates a block diagram of a pulse oximeter system in accordance with an exemplary embodiment of the present invention;

[0018] FIG. 2 illustrates spatial symmetry of the light sources in accordance with an exemplary embodiment of the present invention;

[0019] FIG. 3 illustrates an emission intensity plot of an emitter in accordance with an embodiment of the present invention;

[0020] FIG. 4 illustrates the emission intensity plots of two emitters spectrally symmetrical relative to a central wavelength in accordance with embodiments of the present invention;

[0021] FIG. 5 illustrates an electrical configuration for LEDs of a pulse oximeter in accordance with an exemplary embodiment of the present invention; and

[0022] FIG. 6 illustrates a cross-sectional view of a pulse oximeter sensor in accordance with an exemplary embodiment of the present invention.

DETAILED DESCRIPTION OF SPECIFIC EMBODIMENTS

[0023] One or more specific embodiments of the present invention will be described below. In an effort to provide a concise description of these embodiments, not all features of an actual implementation are described in the specification.

It should be appreciated that in the development of any such actual implementation, as in any engineering or design project, numerous implementation-specific decisions must be made to achieve developer's specific goals, such as compliance with system-related and business-related constraints, which may vary from one implementation to another. Moreover, it should be appreciated that such a development effort might be complex and time consuming, but would nevertheless be a routine undertaking of design, fabrication, and manufacture for those of ordinary skill having the benefit of this disclosure.

[0024] In accordance with aspects of the present invention, techniques are disclosed for reducing the susceptibility of pulse oximeters to error caused by motion or spectral variation of light sources. Additionally, techniques are disclosed that allow for the operation of pulse oximetry systems with a broad spectral content and, potentially, without calibration.

[0025] Turning to FIG. 1, a block diagram of a pulse oximeter system in accordance with an exemplary embodiment of the present invention is illustrated and generally designated by the reference numeral 10. The pulse oximeter system 10 includes a sensor 11 having a detector 12 which receives electromagnetic radiation from the blood perfused tissue of a patient 14. The electromagnetic radiation originates from emitters 16. A photoelectric current is generated when the electromagnetic radiation scattered and absorbed by the tissue arrives at the detector 12. The current signal produced by the detector 12 is amplified by an amplifier 18 prior to being sent to the pulse oximeter 20.

[0026] The emitters 16 may be one or more LEDs configured to emit in the red and near infrared regions of the electromagnetic spectrum. As will be explained in greater detail below, the emitters 16 may be oriented to provide spatial symmetry about an axis. Additionally, the emitters 16 may be spectrally symmetrical about a central wavelength to eliminate the use of a spectrum calibration model.

[0027] In addition to providing a signal corresponding to the amount of electromagnetic radiation scattered and absorbed by the tissue, the sensor 11 may also be configured to provide calibration data to the pulse oximeter 20 via an encoder 21. Pulse oximetry algorithms typically use coefficients indicative of certain parameters of a particular system. The particular set of coefficients chosen for a particular set of wavelength spectra is determined by the value indicated by encoder 21 corresponding to a particular light source in a particular sensor. In one configuration, multiple resistor values may be assigned to select different sets of coefficients. In this instance, the encoder 21 may include one or a plurality of resistor values and a detector 22 located in the pulse oximeter 20 reads the resistor values and selects coefficients from a stored table. Alternatively, the encoder 21 may be a memory that either stores the wavelength information or the coefficients. Thus, the encoder 21 and the decoder 22 allow the pulse oximeter 20 to be calibrated according to the particular wavelengths of the emitters 16.

[0028] In an exemplary embodiment, the pulse oximeter 20 includes a microprocessor 24 that processes data received from the sensor 11 to compute various physiological parameters. The pulse oximeter 20 may also include a random access memory (RAM) 26 for storing data and an output display 28 for displaying computed parameters. A time processing unit (TPU) 30 may be provided to control the timing of the pulse oximeter 20. The TPU may be coupled

to light drive circuitry 32 and a switch 34. The light drive circuitry 32 controls light emissions of the emitters 16, and the switch 34 receives and controls the gating-in of the amplified signals from the detector 12. The received signals are passed from the switch 34 through a second amplifier 36, a filter 38, and an analog-to-digital converter (A/D) 40, before arriving at the microprocessor 24.

[0029] Upon receiving the signals, the microprocessor 24 calculates the oxygen saturation and other physiological parameters. In calculating the physiological parameters, the microprocessor 24 uses algorithms stored on a read-only memory (ROM) 44 and data stored in the RAM 26. As discussed above, the algorithms typically use coefficients which correspond to the wavelengths of light used and calibrate the pulse oximeter 20 to the particular wavelengths being used. Implementation of spectral symmetry techniques may, however, eliminate such calibration.

[0030] The display 28 outputs the physiological parameters, such as oxygen saturation, calculated by the pulse oximeter 20. The block diagram of the pulse oximeter system 10 is exemplary, and it should be understood that various alternative configurations may be possible. For example, there may be multiple parallel paths of separate amplifiers, filters, and A/D converters for multiple light wavelengths or spectra received. Additionally, implementation of spectral symmetry techniques may obviate the encoder 21 and decoder 22.

[0031] Spatial symmetry of the emitters 16 may provide a level of immunity against motion induced artifacts. FIG. 2 diagrammatically illustrates the emitter portion of a sensor having emitter LEDs 64, 65 and 66 symmetrically oriented relative to an axis 62 in accordance with an exemplary embodiment of the present invention. The first LED 64 is positioned on one side of the center LED 65, while the second LED 66 is positioned on the other side of the center LED 65. The axis 62 runs through the center of the center LED 65 and may represent the long axis of a patient's finger to which the LEDs may couple. The center LED 65 typically emits radiation in the infrared (IR) or near infrared (NIR) range, while the LEDs 64 and 66 have similar spectral outputs in the red range of approximately 600 to 800 nm to help ensure that any coupling issues that may occur due to movement of tissue relative to one LED may be compensated for by the other LED. For example, if the finger moves away from the LED 64, resulting in poor coupling with LED 64, the coupling of the finger with LED 66 may still exhibit good coupling or even improved coupling due to the movement.

[0032] As discussed above, pulse oximeters typically employ light sources that operate in the near infrared (NIR)/infrared (IR) and the red range of the electromagnetic spectrum. The different wavelengths of light generate different levels of current in the photodetector 12. As the red range produces a lower photocurrent in the photodetector 12, LEDs that emit in this range may be selected as the LEDs 64 and 66. Because the signal from the two LEDs 64 and 66 is additive, the signal-to-noise ratio of the sensor may be increased, thus, providing better readings.

[0033] In addition to the LEDs 64 and 66 being physically disposed in a symmetrical relationship, or in the alternative, the wavelengths of the LEDs 64 and 66 may be spectrally symmetrical with respect to one another. Spectral symmetry of the LEDs 64 and 66 may be implemented in combination with or independent from the spatial symmetry described

above. FIG. 3 illustrates the emission intensity plot of an exemplary light emitter relative to the wavelength. Specifically, FIG. 3 illustrates that the emitter exhibits an emission intensity maximum at a center wavelength λ_c . The wavelengths λ_{64} and λ_{66} of the LEDs 64 and 66 are shown symmetrically disposed about the center wavelength λ_c . To provide spectral symmetry, two emitters are used that have emission intensity maxima at wavelengths equidistant in nanometers from the central wavelength λ_c and on opposite spectral sides of the central wavelength λ_c , which may be selected to be 660 nm, for example. Specifically, the two wavelengths λ_{64} and λ_{66} are selected to have maxima at wavelengths that overlap at their half power level or greater at the center wavelength λ_c such that when summed together they achieve a maximum intensity at the center wavelength λ_c , where the maximum intensity is greater than that of either LED 64 or LED 66 alone. For example, if the spectral bandwidth of the wavelengths λ_c , λ_{64} and λ_{66} are the same, two wavelengths λ_{64} and λ_{66} may be selected to correspond to the half power level or greater of the center wavelength λ_c . In other words, if the LED 64 has a maximum at 650 nm and the LED 66 has a maximum at 670 nm and the respective signals have not decreased beyond their half power level (-3 dB) at 660 nm, then the additive maximum of the LED 64 and LED 66 will occur at 660 nm. Thus, a stronger signal at the center wavelength, such as 660 nm may be achieved through spectral symmetry techniques.

[0034] Additionally, the use of spectral symmetry may eliminate the need for a calibration model. The hemoglobin (HbO₂ and HHb) spectra vary more rapidly as a function of wavelength at 660 nm than at 940 nm. Therefore, the precise spectral content of the red light source is more critical than that of the NIR/IR light source. Accurate predictions of oxygen saturation may be achieved by modification of the calibration model according to the spectral content of the particular red light sources being used, as discussed above. Spectral symmetry techniques, however, may be used to obviate calibration.

[0035] Referring to FIG. 4, the emission intensity of the two LEDs 64 and 66 having maxima at wavelengths λ_{64} and λ_{66} , which are symmetrical about the center wavelength λ_c , e.g., approximately 660 nm, are illustrated. A maximum at the center wavelength, indicated by the dashed line 67, occurs due to the additive effects of the LEDs 64 and 66 emitting at the spectrally symmetrical wavelengths λ_{64} and λ_{66} which overlap at their half power level or greater. As discussed above, even though the LEDs 64 and 66 are not operating at the center wavelength λ_c , they may combine to create a maximum at the center wavelength λ_c . Thus, the technique of spectral symmetry may eliminate the wavelength specific calibration because the LEDs 64 and 66 are selected to be summed to create a maximum at the center wavelength λ_c for which the pulse oximeter may already be programmed. It is inherent in this technique that the wavelength maximum, and not the spectral width of the light source, is used for the calibration of oximeter sensor light sources.

[0036] Furthermore, because the light sources are spectrally symmetrical and their intensities may add to have a maximum at the center wavelength λ_c , a wider range of light source spectra may be used. For example the range of currently allowed wavelengths for the 660 nm LEDs is approximately 650 nm to 670 nm. According to the techniques presented herein, however, it may be possible to use

LEDs emitting outside the range of wavelengths between 650 and 670 nm. For example, a first LED can be selected to have an emission peak at a wavelength less than 670 nm, such as 648 nm, and second LED may be selected to have an emission peak at a wavelength greater than 650 nm, such as 672 nm. As long as signals from the first and second LEDs overlap at half power (-3 dB) or greater, a peak will be created by the overlap. Assuming that each LED has an equivalent spectral bandwidth, there will be a peak at 660 nm. Alternatively, the first LED can be selected to emit at 640 nm and the second LED can be selected to emit at 660 nm, thus providing spectral symmetry at 650 nm. Again, as long as the signals emitted from the first and second LEDs overlap at half power or greater at 650 nm, there will be a peak at 650 nm. The use of LEDs producing maxima at wavelength other than 660 nm, however, may require a calibration model to compensate for the lack of absorbance of hemoglobin at that particular wavelength. Additionally, the actual range of wavelengths that may be implemented may be limited by several factors, including the spectral bandwidth of the particular LEDs, the photosensitivity of the detector and limits on the spectrophotographic response of hemoglobin at wavelengths other than 660 nm. Specifically, if the LEDs only have a spectral bandwidth of twenty nanometers, the spectrally symmetrical LEDs can only have peaks twenty nanometers or less apart (i.e. ten nanometers from a desired center wavelength).

[0037] In an alternative exemplary embodiment, the implementation of the spectral symmetry techniques may produce a peak having a broader spectral bandwidth, rather than increasing the magnitude of the signal at the center wavelength. Specifically, the peak generated by summing the emitted wavelengths may not necessarily be greater than the peak generated by the individual LEDs **64** and **66** themselves. For example, the summed peak may have a magnitude approximately equivalent to the magnitude of peaks generated by the LEDs **64** and **66** alone. Accordingly, the intensity of the emissions across the spectra will be relatively flat between the wavelengths being used and at the center wavelength. The combined signal would provide a broader spectral bandwidth at the center wavelength, as the bandwidth extends from half power level on the blue side of the signal from LED **64** to the half power level on the red side of the LED **66**.

[0038] An exemplary schematic of the electrical configuration of the multiple LEDs is illustrated in FIG. **5**. The configuration of the LEDs may be the same regardless of whether the emitters provide spectral and/or spatial symmetry. The two LEDs **64** and **66** are electrically configured to emit light coincidentally, whereas the center LED **65** is configured to emit light while the LEDs **64** and **66** are off.

[0039] Turning to FIG. **6**, a cross sectional view of a sensor in accordance with an exemplary embodiment of the present invention is illustrated and generally designated by the reference numeral **68**. The cross sectional view of the sensor **68** shows a plurality of LEDs **64**, **65** and **66** oriented about an axis **62**. The center LED **65** and the detector **16** are bisected by the axis **62**. The LEDs **64**, **65**, and **66** transmit electromagnetic radiation through a patient's tissue **14** which is detected by the detector **16**. The housing **70** of the pulse oximeter **68** may be designed to limit movement of the patient **14** relative to the LEDs **64**, **65**, **66** and the detector **16**, thus, reducing artifacts due to motion and poor coupling of the LEDs **64**, **65**, **66** and detector **16** to the patient.

Specifically, the sensor **68** includes a curved shape about the patient's tissue **14** which permits rocking movement according to the curved shape of the housing **70**, but which limits other movement. Movement such as rocking along the curvature of the housing **70** may be anti-correlated by the spatial symmetry of the sensor **68**, thus reducing motion-induced artifacts.

[0040] As stated above, spatial symmetry techniques may be used in combination with or independent of the spectral symmetry technique. When implemented in a system that does not have spectral symmetry, it may be desirable to calibrate the pulse oximeter. When spectral symmetry techniques are implemented, the calibration may be unnecessary, as described above. In the event that spectral symmetry is implemented and the λ_c is not 660 nm, it may still be desirable to calibrate according to the particular λ_c .

[0041] Several advantages are achieved by implementing the techniques described herein. For example, spatial symmetry may provide anti-correlation of motion-induced artifacts and increase the signal-to-noise ratio. Motion-induced artifacts are typically a result of changes in the coupling of the sensor with the patient's tissue. The spatial symmetry anti-correlates the motion induced artifacts by providing two LEDs symmetrically disposed about an axis of movement such that as the patient's tissue moves away from one LED the tissue couples with another LED operating at the same wavelength. Additionally, the summed signal from the symmetrically disposed LEDs may provide a stronger signal than a single LED to improve the signal-to-noise ratio for wavelengths which have a weaker photodetection effect.

[0042] The implementation of spectral symmetry may also provide a stronger signal at wavelengths which have a weaker photo detection effect. The combined emission strength of the two LEDs spectrally oriented about a central wavelength may provide a stronger signal for detection if each of LEDs have emission wavelengths which overlap above their half power level, as described above with reference to FIG. **4**. Furthermore, the spectral symmetry allows the use of LEDs having a wider range of spectral content. Selecting light sources having maxima symmetrically disposed about a center wavelength in the range of 650 to 670 nm allows for a summed signal with a maximum within the 650 to 670 nm range. Thus, LEDs emitting outside of the 650 to 670 nm range may be used when paired with an LED having a peak emission wavelength symmetrically disposed about the center wavelength, as long as the spectra of the LEDs overlap at the center wavelength at their respective half power levels or greater.

[0043] Implementation of spectral symmetry may also allow for calibration-free sensors. Assuming that the wavelength maximum and not the spectral width of the LEDs is the most important aspect of the calibration, a center wavelength can be selected about which LED pairings are spectrally symmetrical. The pulse oximeter **20** can be set to operate according to a center wavelength, i.e. according to coefficients associated with the center wavelength, and no calibration is required. If variable spectral width due to the use of two LEDs is found to limit the accuracy of the measurement, an optical coating could be applied either to the light source or detector to limit the spectral width. For example, the detector could be coated with a material that passes light only with bands around 660 and 890 nm, but blocks the detection of light in all other spectral regions. In this way, the detected spectral band width would be prima-

rily determined by the spectral width of the optical bandpass filter. This aspect of the invention would have the additional advantage of greatly limiting the influence of ambient light on the measured signal. Examples of suitable coatings include multilayer dielectric films and light-absorbing dyes. [0044] While the invention may be susceptible to various modifications and alternative forms, specific embodiments have been shown by way of example in the drawings and have been described in detail herein. However, it should be understood that the invention is not intended to be limited to the particular forms disclosed. Indeed, the present techniques may not only be applied to measurements of pulse oximetry, but these techniques may also be utilized for the measurement and/or analysis of other blood or tissue constituents. Rather, the invention is to cover all modifications, equivalents, and alternatives falling within the spirit and scope of the invention as defined by the following appended claims. It will be appreciated by those working in the art that sensors fabricated using the presently disclosed and claimed techniques may be used in a wide variety of contexts.

What is claimed is:

1. A sensor for pulse oximeter systems comprising:
 - a first source of electromagnetic radiation configured to operate at a first wavelength;
 - a second source of electromagnetic radiation configured to operate at a second wavelength;
 - a third source of electromagnetic radiation configured to operate at a third wavelength, wherein the emission spectra of the first and third sources of electromagnetic radiation overlap at their half power level or greater and correspond to a center wavelength in the range of 650 to 670 nm; and
 - a photodetector configured to receive electromagnetic radiation from blood-perfused tissue irradiated by the first, second and third sources of electromagnetic radiation.
2. The sensor of claim 1, wherein the first and third sources of electromagnetic radiation emit in the red region of the electromagnetic spectrum.
3. The sensor of claim 1, wherein the first source of electromagnetic radiation has an emission maximum at less than 670 nm and the third source has an emission maximum in greater than 650 nm, the emission maximum of the third source occurring at a wavelength greater than the emission maximum of the first source and wherein the first and third sources of electromagnetic radiation are spectrally equidistant from the center wavelength.
4. The sensor of claim 1, wherein the first and third sources of electromagnetic radiation are spatially oriented symmetrically about an axis wherein the axis bisects the second source of electromagnetic radiation.
5. The sensor of claim 1, wherein the second source of electromagnetic radiation is configured to emit in the near-infrared region of the electromagnetic spectrum.
6. The sensor of claim 1, wherein the second source of electromagnetic radiation is configured to emit in the infrared region of the electromagnetic spectrum.
7. The sensor of claim 1, wherein the photodetector is coated with a material that limits the spectral bandwidth of detected light.

8. The sensor of claim 7, wherein the material comprises a multilayer dielectric film.

9. The sensor of claim 7, wherein the material comprises a light-absorbing dye.

10. The sensor of claim 1, wherein at least one of the sources is coated with a material that limits the spectral bandwidth emitted light.

11. The sensor of claim 10, wherein the material comprises a multilayer dielectric film.

12. The sensor of claim 10, wherein the material comprises a light-absorbing dye.

13. A system for determining physiological parameters comprising:

a sensor comprising:

- a first light emitting diode (LED) configured to emit radiation in the red region of the electromagnetic spectrum, the first LED having a maximum wavelength less than 670 nm;
- a second LED configured to operate in the near-infrared region of the electromagnetic spectrum;
- a third LED configured to operate in the red region of the electromagnetic spectrum, the third LED having a maximum wavelength greater than 650 nm, the third LED having a maximum wavelength greater than the first LED, wherein the first LED and third LED are spectrally symmetrical with respect to a center wavelength in the range 650 to 670 nm; and
- a photodetector configured to generate a signal corresponding to received electromagnetic radiation from blood-perfused tissue irradiated by the first, second and third sources of electromagnetic radiation; and
- a pulse oximeter configured to compute physiological parameters based on the signals generated by the photodetector.

14. The system of claim 13, wherein the first LED and third LED are spatially oriented symmetrically about an axis relative to the second LED.

15. The system of claim 14, wherein the sensor comprises a curved surface configured to allow optical coupling of a patient's finger with the first, second and third LEDs, and the photodetector.

16. The system of claim 15, wherein the curved surface inhibits axial movement of the patient's finger.

17. A method for determining physiological parameters using a pulse oximeter comprising:

- transmitting electromagnetic radiation from a first light emitting diode (LED), a second LED and a third LED, wherein the first and third LEDs operate concurrently and have emission spectra in the red region of the electromagnetic spectrum, the emission spectra overlapping at greater than or equal to a half power level of the respective emission spectra causing a peak corresponding to a center wavelength;
- generating a photoelectrical current corresponding to the electromagnetic radiation from the first, second and third LEDs; and
- computing physiological parameters based on the photoelectrical current.

* * * * *

专利名称(译)	用于脉搏血氧仪的对称LED阵列		
公开(公告)号	US20080081972A1	公开(公告)日	2008-04-03
申请号	US11/541287	申请日	2006-09-29
[标]申请(专利权)人(译)	内尔科尔普里坦贝内特公司		
申请(专利权)人(译)	NELLCOR PURITAN BENNETT INCORPORATED		
当前申请(专利权)人(译)	COVIDIEN LP		
[标]发明人	DEBRECZENY MARTIN P		
发明人	DEBRECZENY, MARTIN P.		
IPC分类号	A61B5/00		
CPC分类号	A61B5/7214 A61B5/14552		
其他公开文献	US8068891		
外部链接	Espacenet	USPTO	

摘要(译)

提供了一种用于脉搏血氧计系统的传感器。传感器包括被配置为以第一波长操作的第一电磁辐射源，被配置为以第二波长操作的第二电磁辐射源，以及被配置为以第三波长操作的第三电磁辐射源。第一和第三电磁辐射源的发射光谱在其半功率水平或更大的水平处重叠，并且对应于650至670nm范围内的中心波长。

