



(19) **United States**

(12) **Patent Application Publication**
Chew et al.

(10) **Pub. No.: US 2006/0264720 A1**

(43) **Pub. Date: Nov. 23, 2006**

(54) **SWITCH-MODE OXIMETER LED DRIVE WITH A SINGLE INDUCTOR**

Publication Classification

(75) Inventors: **Bradford B. Chew, (US); Ethan Petersen, (US); William Shea, (US)**

(51) **Int. Cl.**
A61B 5/00 (2006.01)
H05B 37/00 (2006.01)

Correspondence Address:
FLETCHER YODER (TYCO INTERNATIONAL, LTD.)
P.O. BOX 692289
HOUSTON, TX 77269-2289 (US)

(52) **U.S. Cl.** **600/323; 600/310; 315/186**

(57) **ABSTRACT**

(73) Assignee: **Nellcor Puritan Bennett Incorporated a corporation of Delaware, Pleasanton, CA**

A light emitter drive circuit for an oximeter which utilizes a single inductor for driving multiple light emitters. The inductor is connected to a switching circuit to multiple energy storage circuits, such as capacitors. These are alternately charged up, using the same inductor. Subsequently, the capacitors are alternatively discharged for their corresponding light emitters through he same inductor. Also, the magnetic susceptibility of the LED drive circuit is reduced by using magnetic flux canceling in the inductor. In one embodiment, a toroidal inductor is used with geometric symmetry and its magnetic flux. In other embodiment, a dual core closed bobbin shielded inductor is used.

(21) Appl. No.: **11/494,394**

(22) Filed: **Jul. 26, 2006**

Related U.S. Application Data

(63) Continuation of application No. 10/787,852, filed on Feb. 25, 2004, now Pat. No. 7,120,479.

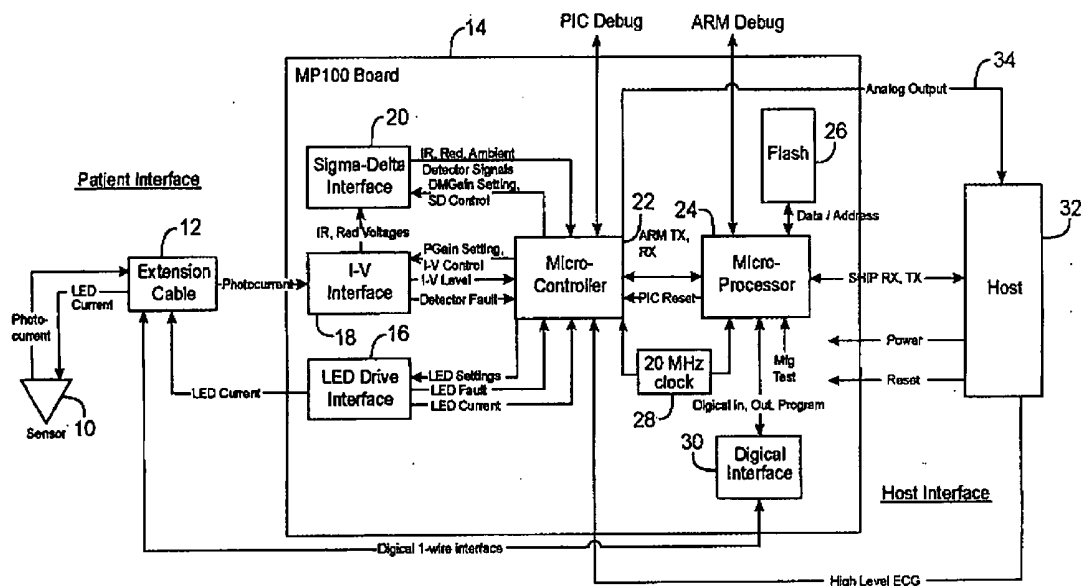

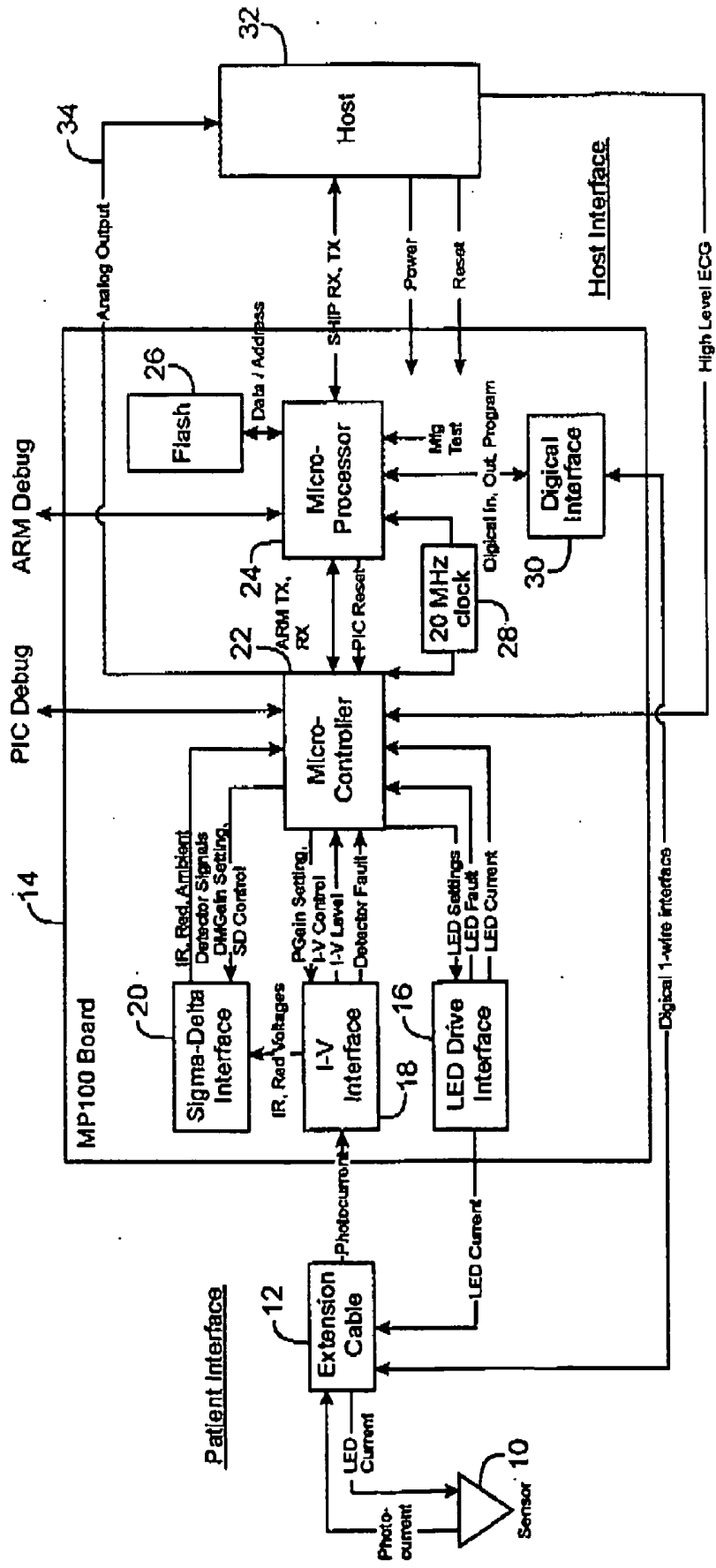

FIG. 1

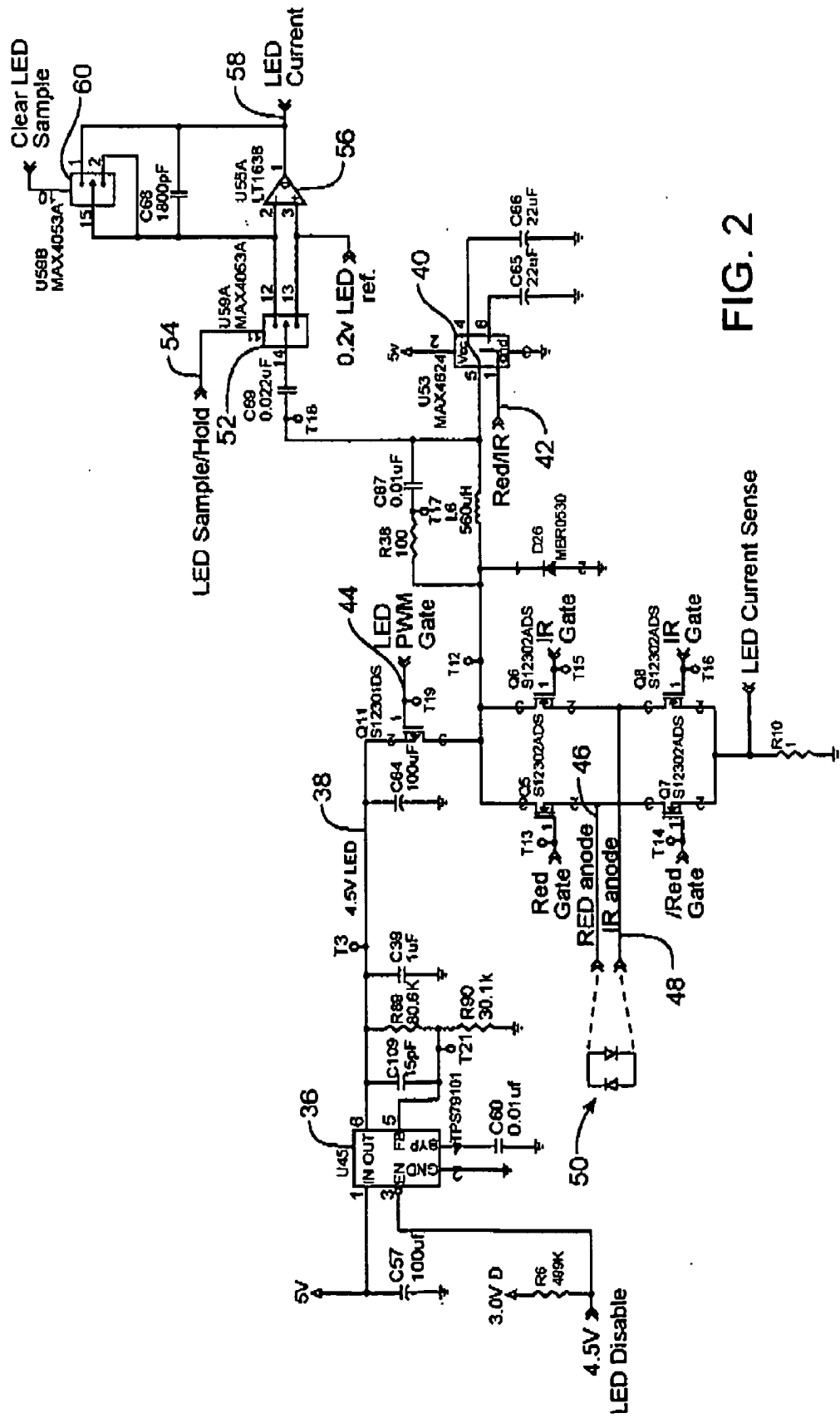

FIG. 2

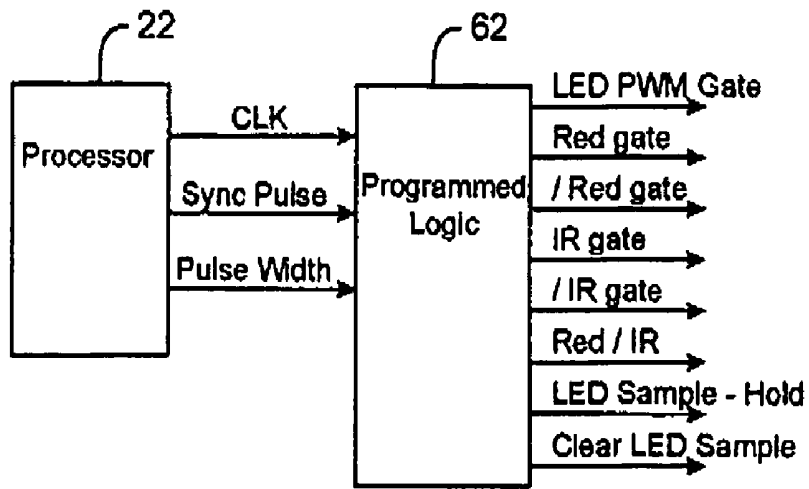

FIG. 3



FIG. 4

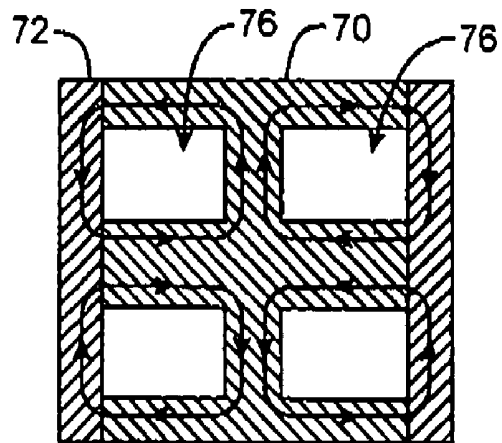

FIG. 5

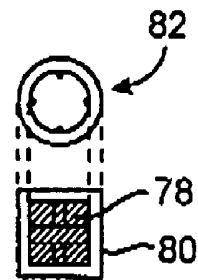

FIG. 6

SWITCH-MODE OXIMETER LED DRIVE WITH A SINGLE INDUCTOR

CROSS-REFERENCE TO RELATED APPLICATIONS

[0001] This application is a continuation of U.S. application Ser. No. 10/787,852, filed on Feb. 25, 2004.

BACKGROUND OF THE INVENTION

[0002] The present invention relates to oximeters, and in particular to LED drive circuits in pulse oximeters.

[0003] Pulse oximetry is typically used to measure various blood chemistry characteristics including, but not limited to, the blood-oxygen saturation of hemoglobin in arterial blood, the volume of individual blood pulsations supplying the tissue, and the rate of blood pulsations corresponding to each heartbeat of a patient. Measurement of these characteristics has been accomplished by use of a non-invasive sensor which scatters light through a portion of the patient's tissue where blood perfuses the tissue, and photoelectrically senses the absorption of light in such tissue. The amount of light absorbed at various wavelengths is then used to calculate the amount of blood constituent being measured.

[0004] The light scattered through the tissue is selected to be of one or more wavelengths that are absorbed by the blood in an amount representative of the amount of the blood constituent present in the blood. The amount of transmitted light scattered through the tissue will vary in accordance with the changing amount of blood constituent in the tissue and the related light absorption. For measuring blood oxygen level, such sensors have typically been provided with a light source that is adapted to generate light of at least two different wavelengths, and with photodetectors sensitive to both of those wavelengths, in accordance with known techniques for measuring blood oxygen saturation.

[0005] Known non-invasive sensors include devices that are secured to a portion of the body, such as a finger, an ear or the scalp. In animals and humans, the tissue of these body portions is perfused with blood and the tissue surface is readily accessible to the sensor.

[0006] The light sources, typically light emitting diodes (LEDs), need to be driven with current to activate them. Because of the significant amount of current required, this can interfere with reducing power consumed by an oximeter. One solution is shown in U.S. Pat. No. 6,226,539. There, an inductor and capacitor circuit is used to first store charge in a first switch position, and then subsequently, in a second switch position, deliver that stored charge to the LED. Two different inductor and capacitor circuits are used, one for each LED. It would be desirable to reduce the number of components required in the circuit of this patent.

BRIEF SUMMARY OF THE INVENTION

[0007] The present invention provides a light emitter drive circuit for an oximeter which utilizes a single inductor for driving multiple light emitters. The inductor is connected through a switching circuit to multiple energy storage circuits, such as capacitors. These are alternately charged up, using the same inductor. Subsequently, the capacitors are alternately discharged to activate their corresponding light emitters through the same inductor.

[0008] In another aspect of the present invention, the magnetic susceptibility of the LED drive circuit is reduced by using magnetic flux canceling in the inductor. In one embodiment, a toroidal inductor is used with geometric symmetry in its magnetic flux. In another embodiment, a dual core closed bobbin shielded inductor is used. This embodiment has windings of both cores in series that are used to cancel the effect of an external magnetic field.

[0009] For a further understanding of the nature and advantages of the present invention, reference should be made to the following description taken in conjunction with the accompanying drawings.

BRIEF DESCRIPTION OF THE DRAWINGS

[0010] FIG. 1 is a block diagram of an oximeter incorporating the present invention.

[0011] FIG. 2 is a circuit diagram of a LED drive circuit according to an embodiment of the present invention.

[0012] FIG. 3 is a block diagram of one embodiment of the logic for generating the timing and control signals for the circuit of FIG. 2.

[0013] FIG. 4 is a diagram of a toroidal inductor used in one embodiment of the present invention.

[0014] FIGS. 5 and 6 are diagrams of a dual core inductor according to an embodiment of the present invention.

DETAILED DESCRIPTION OF THE INVENTION

Oximeter System

[0015] FIG. 1 illustrates an embodiment of an oximetry system incorporating the present invention. A sensor 10 includes red and infrared LEDs and a photodetector. These are connected by a cable 12 to a board 14. LED drive current is provided by an LED drive interface 16. The received photocurrent from the sensor is provided to an I-V interface 18. The IR and red voltages are then provided to a sigma-delta interface 20 incorporating the present invention. The output of sigma-delta interface 20 is provided to a microcontroller 22. Microcontroller 22 includes flash memory for a program, and SRAM memory for data. The processor also includes a microprocessor chip 24 connected to a flash memory 26. Finally, a clock 28 is used and an interface 30 to a digital calibration in the sensor 10 is provided. A separate host 32 receives the processed information, as well as receiving an analog signal on a line 34 for providing an analog display.

LED Drive Circuit

[0016] FIG. 2 is a circuit diagram of the LED drive circuit according to an embodiment of the invention, which forms a portion of LED drive interface 16 of FIG. 1. A voltage regulator 36 provides a voltage separate from the voltage supply for the overall oximeter circuitry. The output is provided as a 4.5 volt signal on line 38, with the level being set by the feedback resistor divider of resistors R89 and R90. The voltage on line 38 is provided to a FET transistor Q11 to an inductor L6. The current through inductor L6 is provided by a switch 40 to one of capacitors C65 and C66, which store charge for the red and IR LEDs, respectively. A red/IR control signal on line 42 selects the switch position

under control of the oximeter processor. A control signal LED PWM gate on line 44 controls the switching of transistor switch Q11.

[0017] Once the capacitors are charged up, the control signal on line 44 turns off switch Q11 and current is provided from either capacitor C65 or C66, through switch 40 and inductor L6 to either the red anode line 46 or the IR anode line 48 by way of transistors Q5 and Q6, respectively. A signal "red gate" turns on transistor Q5, while its inverse, "red gate" turns off transistor Q7. This provides current through the red anode line 46 to the back LEDs 50, with the current returning through the IR anode to transistor Q8 and through resistor R10 to ground. Transistor Q8 is turned on by the signal "IR gate" while the inverse of this signal, "IR gate" turns off transistor Q6. The signals are reversed when the IR anode is to be driven, with the "IR gate" and "red gate" signals, and their inverses, changing state, so that current is provided through transistor Q6 to IR anode 48 and returns through red anode 46 and through transistor Q7 to resistor R10 and ground. The "LED current sense" signal is read for calibration purposes not relevant to the present invention.

[0018] When the current from the capacitor C65 or C66 is provided through inductor L6 to the LEDs, and that current is switched off at the desired time, transistor Q11 is turned on so that the remaining current during the transition can be dumped into capacitor C64. This addresses the fact that the FET transistor switching is not instantaneous. Subsequently, C64 will dump its current through Q11 and inductor L6 into the capacitors when they are recharged.

[0019] Resistor R38 and capacitor C67 are connected in parallel to inductor L6 to protect against signal spikes, and provide a smooth transition. Connected to inductor L6 is a sampling circuit with a switch 52 controlled by an LED sample hold signal on line 54 to sample the signals and provide them through an amplifier 56 to a "LED current" signal on line 58 which is read by the processor. Operational amplifier 56 operates between 4.5 volts and ground. Thus, a voltage reference slightly above ground, of 0.2 volts, is provided as a voltage reference on pin 3. An integrating capacitor C68 is provided in parallel to amplifier 56. A switch 60 responds to a "clear LED sample" signal to operate the switch to short out the capacitor between samples.

[0020] The sample and hold circuit measures the voltage at node T18, between capacitor C69 and inductor L6, to determine the current. Capacitor C69 is $\frac{1}{1000}$ of the value of capacitors C65 and C66. Thus, a proportional current is provided through C69, which is injected through switch 52 to integrating capacitor C68 to provide a voltage which can be measured at the output of amplifier 56 on line 58. The voltage measured by the processor on line 58 is used as a feedback, with the processor varying the width of the pulse delivered to transistor Q11 to selectively vary the amount of energy that's delivered to the capacitors 65 and 66, and then is eventually discharged to the LEDs 50. A PI (Proportional Integral) loop inside the processor then controls the PWM signal at Q11. This allows precise control of the LED intensity, allowing it to be maximized, if desired, without exceeding the desired limits (to avoid burning the patent, etc.).

[0021] The lower left of the diagram shows a "4.5 v LED disable" signal which is used by the microprocessor to turn

off the voltage regulator 36 in certain instances. For example, diagnostics looking for shorts in a new sensor plugged in will turn off the voltage regulator if there is a problem with the LED line.

[0022] FIG. 3 illustrates processor 22, from FIG. 1, connected to programmed logic 62, which is in the LED drive interface 16 in FIG. 1. Programmed logic 62 provides the different control signals used by the circuit of FIG. 2 in response to basic timing signals from the processor of a clock, a sync pulse, and a pulse width signal.

[0023] Thus, the present invention provides an improvement over the circuit shown in U.S. Pat. No. 6,226,539 by moving the switch position between the inductor and the capacitors to eliminate the need for two inductors. This not only reduces the part count, requiring only one inductor instead of two, but also provides better matching between the red and IR drive currents since both use the same inductor.

[0024] In another aspect of the invention, the LED drive circuit's susceptibility to magnetic interference is reduced. This magnetic interference can distort the detected pleth waveform. This is minimized by using magnetic flux canceling in the inductor. In one embodiment, this is a toroidal inductor as shown in FIG. 4. The toroidal inductor has a geometric symmetry in its magnetic flux. Another embodiment uses a dual core closed bobbin shielded inductor, such as shown in FIGS. 5 and 6. The windings of both cores in series are used to cancel the effect of an external magnetic field. These magnetic flux canceling inductors can be used either in the circuit of FIG. 2, or could be used in the dual inductor embodiment of the prior art. FIG. 5 shows the dual core inductor with a bobbin 70 in a cylinder 72. The wires are wound through gaps 76, as shown in FIG. 6. A first winding 78 is clockwise, while a second winding 80 is counterclockwise. A top view 82 is also shown. Ideally, the combined inductance in one embodiment is 680 uH.

[0025] The invention as illustrated in the embodiment of FIG. 2 enables the multiplexing of current, through an H-bridge topology, to back-to-back LEDs. Alternately, a different number of loads could be provided. The present invention is scalable to N-loads. The present invention is scalable to N-loads. The present invention provides significant efficiencies through reduction of support components, choice of components, and the properties of "loss-less" capacitor and inductor storage devices. The circuit of FIG. 2 can handle a range of forward voltage drops across the LEDs. The voltage provided varies automatically in accordance with the LED voltage drop, and does not put out more energy than it needs to.

[0026] The circuit is dynamically controlled through a PI loop in the processor, with current feedback being provided by the capacitive current divider from each storage capacitor (C65 and C66), which provides isolation. The feedback can be calibrated with a traditional in-line sense resistor, R10. In addition, this technique allows adjustment of the peak current for optimal signal-to-noise during the sampling period.

[0027] The addition of the upstream linear regulator 36 enhances power supply rejection capability, while the PI loop provides additional power supply insensitivity (to draft, P-P, surge, etc.).

[0028] As will be appreciated by those with skill in the art, the present invention can be embodied in other specific

forms without departure from the essential characteristics thereof. For example, instead of two drive lines, three drive lines could be provided by adding another leg with FET transistor switches connected to the inductor. Additionally, this could be scalable to more than three legs connected in parallel, similar to the leg of Q6, Q8, and the leg of Q5, Q7. Accordingly, the foregoing description is intended to be illustrative, but not limiting, of the scope of the invention which is set forth in the following claims.

1. A light emitter drive circuit for an oximeter comprising:
 - voltage generating circuit;
 - an inductor coupled to the voltage generating circuit;
 - first switching circuit coupled to a first node of the inductor;
 - first and second energy storage circuits connected to the first switching circuit, such that current from the inductor can be steered by the first switching circuit to one of the energy storage circuits;
 - a second switching circuit coupled to a second node of the inductor; and
 - first and second light emitter drive lines connected to the second switching circuit, such that energy from the first and second energy storage circuits can be alternately coupled to the first and second light emitter drive lines.
2. The circuit of claim 1 wherein the first and second energy storage circuits comprise first and second capacitors.
3. The circuit of claim 1 wherein the voltage generating circuit is a voltage regulator separate from a supply voltage for a remainder of the oximeter.
4. The circuit of claim 1 comprising a resistor and a capacitor in parallel with the inductor.
5. The circuit of claim 1 wherein the inductor is a magnetic flux canceling inductor.
6. The circuit of claim 5 wherein the inductor is a torodial inductor.
7. The circuit of claim 5 wherein the inductor is a dual core closed bobbin shielded inductor.
8. The circuit of claim 1 comprising a sample and hold circuit connected to the second node of the inductor.
9. The circuit of claim 1 comprising at least a third energy storage circuit.
10. A light emitter drive circuit for an oximeter comprising:
 - a voltage generating circuit;
 - first and second energy storage circuits;
 - a magnetic flux canceling inductor coupled to the voltage generating circuit and at least one of the energy storage circuits; and
 - switching circuitry configured to first steer current into the energy storage circuits, and then provide energy from the first and second energy storage circuits to drive lines for light emitters.
11. A method comprising:
 - directing electrical current through an inductor in a first direction to an energy storage device;
 - storing energy in an energy storage device;

directing electrical current from an energy storage device through the inductor in a second direction; and

- providing a drive signal to a light emitter drive line.
12. The method of claim 11 wherein directing electrical current through the inductor in a first direction comprises coupling the inductor to a voltage generating source.
 13. The method of claim 11 wherein directing energy through the inductor in a second direction comprises uncoupling the inductor from a voltage generating source.
 14. The method of claim 11 wherein storing energy in the energy storage device comprises coupling the energy storage device to the inductor using a switching device.
 15. The method of claim 14 wherein coupling the energy storage device to the inductor using the switching device comprises alternately coupling a first energy storage device and a second energy storage device to the inductor.
 16. The method of claim 11 wherein providing the drive signal to the light emitter drive line comprises alternately providing the drive signal to a red light emitting diode and an infrared light emitting diode using switches.
 17. The method of claim 11 comprising using a magnetic flux canceling inductor.
 18. The method of claim 17 wherein the magnetic flux canceling inductor comprises a torodial inductor.
 19. The method of claim 17 wherein the magnetic flux canceling inductor comprises a dual core bobbin shielded inductor.
 20. A method of manufacture comprising:
 - providing a switch to couple a voltage generating circuit to an inductor;
 - coupling a first node of the inductor to a first switching circuit and a second node of the inductor to a second switching circuit;
 - configuring the first switching circuit to alternately connect with a first energy storage device and a second energy storage device; and
 - configuring the second switching circuit to alternately supply power to a first light emitting drive line and a second light emitting drive line.
 21. A system comprising:
 - a sensor comprising a first light emitter drive line and a second light emitter drive line;
 - a board electrically coupled to the sensor, the board comprising:
 - a voltage generating circuit;
 - an inductor coupled to the voltage generating circuit;
 - a first switching circuit coupled to a first node of the inductor;
 - first and second energy storage circuits connected to the first switching circuit, such that current from the inductor can be steered by the first switching circuit to one of the energy storage circuits;
 - a second switching circuit coupled to a second node of the inductor, the second switching circuit connected to the first and second light emitter drive lines such that energy from the first and second energy storage circuits can be alternately coupled to the first and second light emitter drive lines.

22. The circuit of claim 21 wherein the first and second energy storage circuits comprise first and second capacitors.

23. The circuit of claim 21 wherein the voltage generating circuit is a voltage regulator separate from a supply voltage for a remainder of the system.

24. The circuit of claim 21 comprising a resistor and a capacitor in parallel with the inductor.

25. The circuit of claim 21 wherein the inductor comprises a magnetic flux canceling inductor.

26. The circuit of claim 25 wherein the inductor comprises a torodial inductor.

27. The circuit of claim 25 wherein the inductor comprises a dual core closed bobbin shielded inductor.

28. The circuit of claim 21 comprising a sample and hold circuit connected to the second node of the inductor.

* * * * *

专利名称(译)	具有单个电感器的开关模式血氧计LED驱动器		
公开(公告)号	US20060264720A1	公开(公告)日	2006-11-23
申请号	US11/494394	申请日	2006-07-26
[标]申请(专利权)人(译)	内尔科尔普里坦贝内特公司		
申请(专利权)人(译)	NELLCOR PURITAN BENNETT注册成立的股份有限公司特拉华		
当前申请(专利权)人(译)	COVIDIEN LP		
[标]发明人	CHEW BRADFORD B PETERSEN ETHAN SHEA WILLIAM		
发明人	CHEW, BRADFORD B. PETERSEN, ETHAN SHEA, WILLIAM		
IPC分类号	A61B5/00 H05B37/00		
CPC分类号	A61B5/14551		
其他公开文献	US8195262		
外部链接	Espacenet USPTO		

摘要(译)

一种用于血氧计的光发射器驱动电路，其利用单个电感器来驱动多个光发射器。电感器连接到多个能量存储电路（例如电容器）的开关电路。使用相同的电感器交替充电。随后，电容器通过相同的电感器交替地为其相应的光发射器放电。而且，通过在电感器中使用磁通消除来降低LED驱动电路的磁化率。在一个实施例中，使用具有几何对称性及其磁通量的环形电感器。在其他实施例中，使用双芯闭合线圈轴屏蔽电感器。

