



(19) **United States**

(12) **Patent Application Publication**
Chew et al.

(10) **Pub. No.: US 2005/0187449 A1**

(43) **Pub. Date: Aug. 25, 2005**

(54) **OXIMETER RED AND IR ZERO CALIBRATION CONTROL**

(22) Filed: Feb. 25, 2004

Publication Classification

(75) Inventors: **Bradford B. Chew**, San Ramon, CA (US); **Ethan Petersen**, Castro Valley, CA (US); **William Shea**, Livermore, CA (US)

(51) **Int. Cl.⁷ A61B 5/00**

(52) **U.S. Cl. 600/323**

(57) **ABSTRACT**

A pulse oximeter with drive lines for driving red and IR LEDs, and a drive circuit for driving those drive lines. A processor controls the drive circuit using a red zero output line and an IR zero output line directly connected between the processor and the drive circuit. This allows a control signal to directly control the turning off of either the red or IR drive transistors to prevent forward current flow through the red and IR LEDs by overriding the ongoing programmable logic state machine control of the drive transistors. The effects of crosstalk and capacitive coupling are reduced as a result.

Correspondence Address:
TOWNSEND AND TOWNSEND AND CREW, LLP
TWO EMBARCADERO CENTER
EIGHTH FLOOR
SAN FRANCISCO, CA 94111-3834 (US)

(73) Assignee: **Nellcor Puritan Bennett Inc.**, Pleasanton, CA

(21) Appl. No.: **10/788,239**

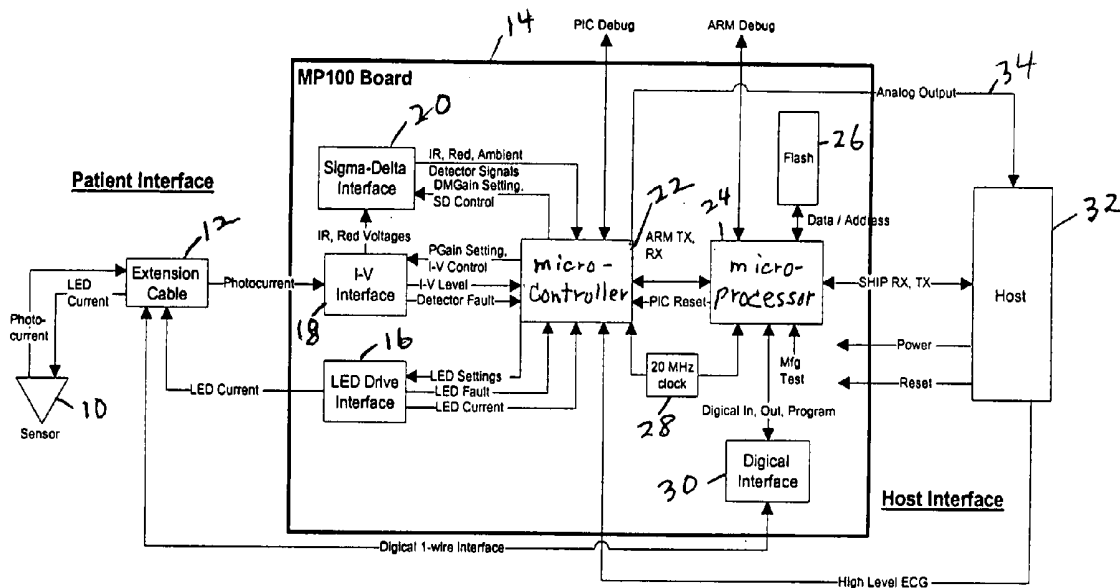

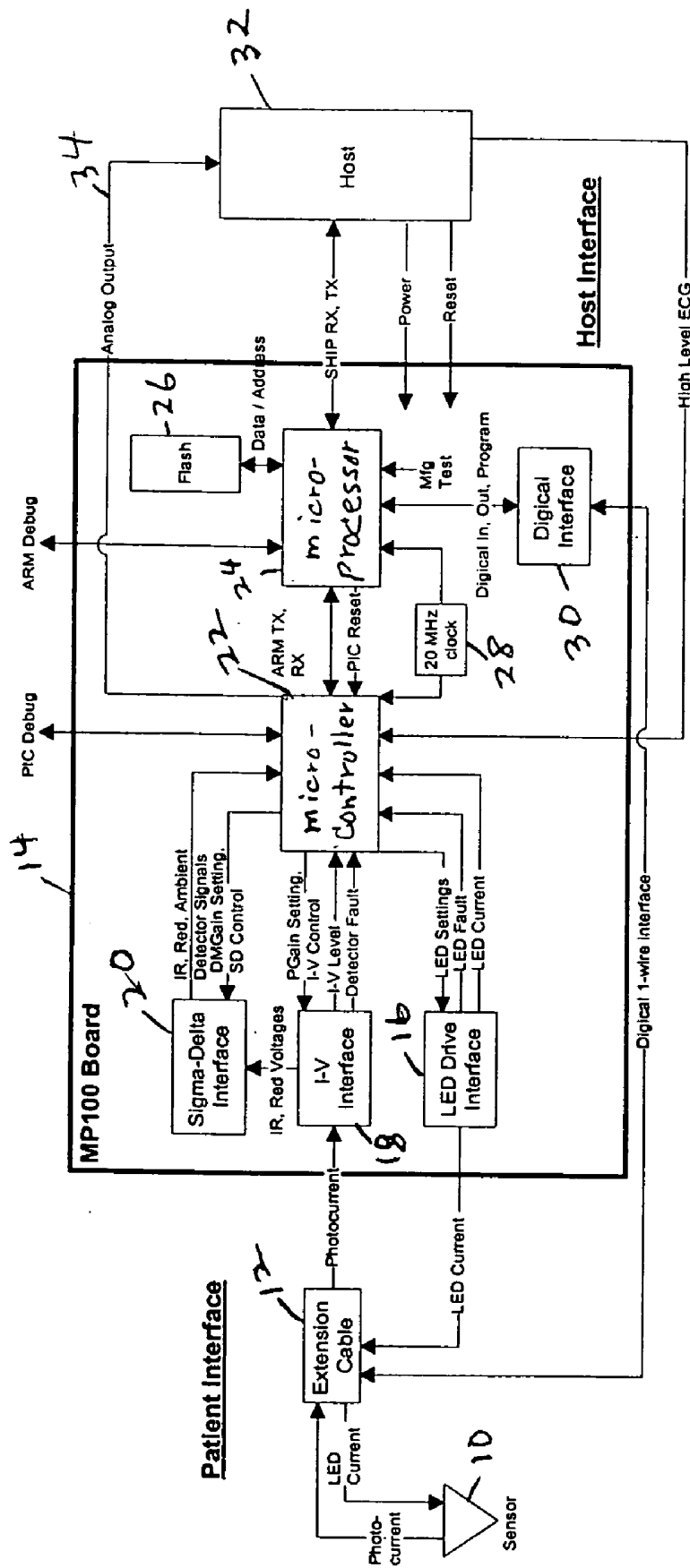

FIG. 1

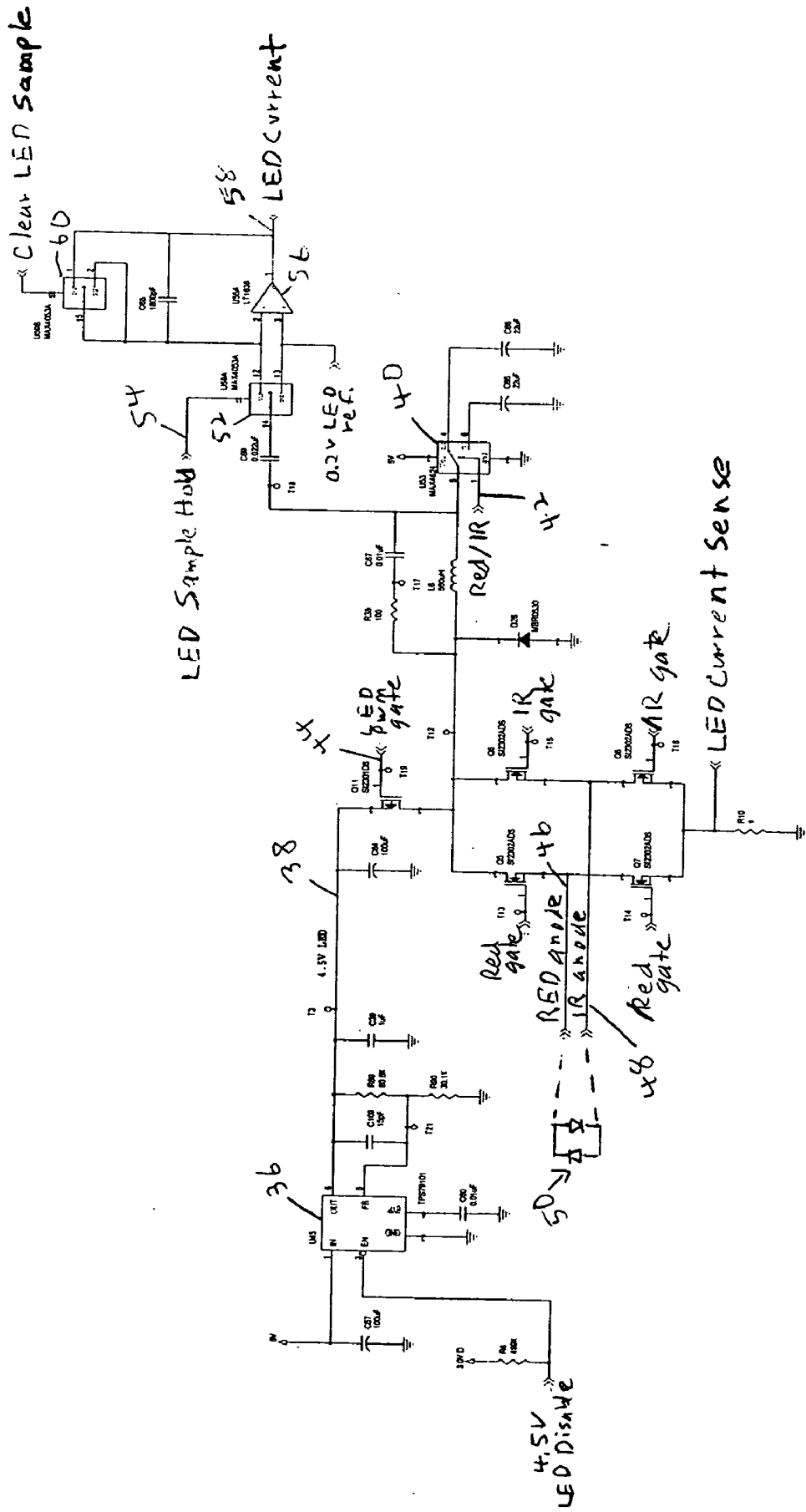

FIG. 2

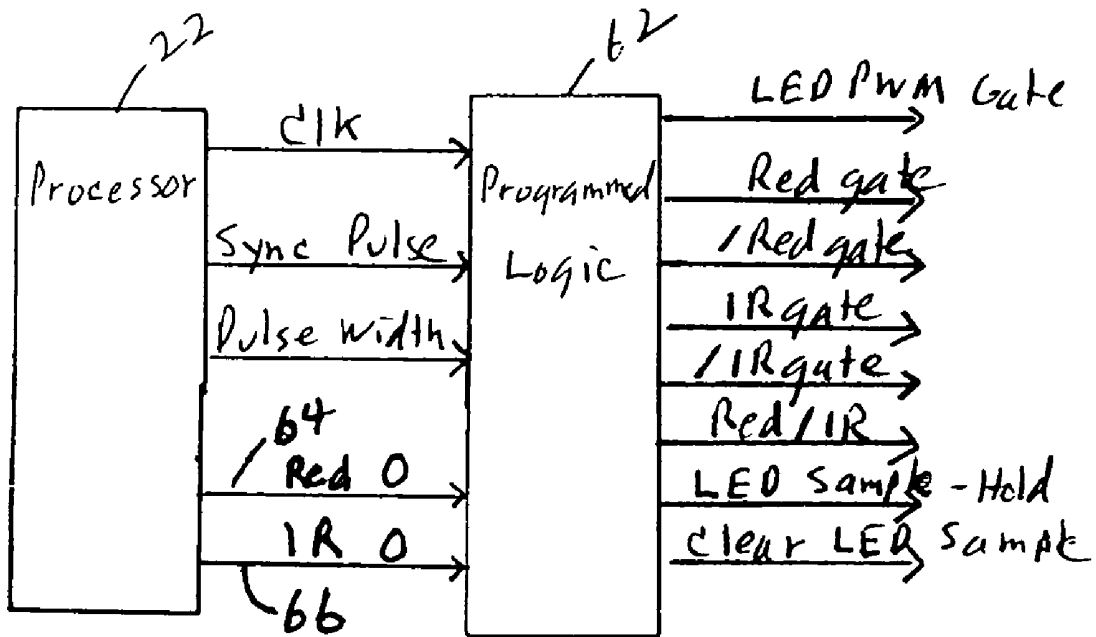

FIG. 3

OXIMETER RED AND IR ZERO CALIBRATION CONTROL

BACKGROUND OF THE INVENTION

[0001] The present invention relates to oximeters, and in particular to LED drive circuits in pulse oximeters.

[0002] Pulse oximetry is typically used to measure various blood chemistry characteristics including, but not limited to, the blood-oxygen saturation of hemoglobin in arterial blood, the volume of individual blood pulsations supplying the tissue, and the rate of blood pulsations corresponding to each heartbeat of a patient. Measurement of these characteristics has been accomplished by use of a non-invasive sensor which scatters light through a portion of the patient's tissue where blood perfuses the tissue, and photoelectrically senses the absorption of light in such tissue. The amount of light absorbed at various wavelengths is then used to calculate the amount of blood constituent being measured.

[0003] The light scattered through the tissue is selected to be of one or more wavelengths that are absorbed by the blood in an amount representative of the amount of the blood constituent present in the blood. The amount of transmitted light scattered through the tissue will vary in accordance with the changing amount of blood constituent in the tissue and the related light absorption. For measuring blood oxygen level, such sensors have typically been provided with a light source that is adapted to generate light of at least two different wavelengths, and with photodetectors sensitive to both of those wavelengths, in accordance with known techniques for measuring blood oxygen saturation.

[0004] Known non-invasive sensors include devices that are secured to a portion of the body, such as a finger, an ear or the scalp. In animals and humans, the tissue of these body portions is perfused with blood and the tissue surface is readily accessible to the sensor.

[0005] The light sources, typically light emitting diodes (LEDs), need to be driven with current to activate them. In order to reduce the effects of leakage and capacitively coupled transients, it is desirable to be able to drive one of the LEDs, without any current going through the other one. Typically, this can be done by controlling the duty cycle with the processor in the pulse oximeter. However, using the duty cycle controls to eliminate current through one of the LEDs has been discovered to still involve an amount of leakage and capacitively coupled transients that is undesirable.

BRIEF SUMMARY OF THE INVENTION

[0006] The present invention provides a pulse oximeter with drive lines for driving red and IR LEDs, and a drive circuit for driving those drive lines. A processor controls the drive circuit using a red zero output line and an IR zero output line directly connected between the processor and the drive circuit. This allows a control signal to directly control the turning off of either the red or IR drive transistors which direct forward current flow through the red and IR LEDs.

[0007] In one embodiment, the red and IR zero output lines are connected to a programmed logic circuit. The programmed logic circuit, which is controlled by the processor, provides the various timing signals for the transistors of the drive circuit. In one embodiment, the drive circuit includes an H-bridge circuit with red and IR FET drive transistors.

[0008] For a further understanding of the nature and advantages of the present invention, reference should be made to the following description taken in conjunction with the accompanying drawings.

BRIEF DESCRIPTION OF THE DRAWINGS

[0009] FIG. 1 is a block diagram of an oximeter incorporating the present invention.

[0010] FIG. 2 is a circuit diagram of a LED drive circuit according to an embodiment of the present invention.

[0011] FIG. 3 is a block diagram of one embodiment of the logic for generating the timing and control signals for the circuit of FIG. 2.

DETAILED DESCRIPTION OF THE INVENTION

[0012] Oximeter Front End

[0013] FIG. 1 illustrates an embodiment of an oximetry system incorporating the present invention. A sensor 10 includes red and infrared LEDs and a photodetector. These are connected by a cable 12 to a board 14. LED drive current is provided by an LED drive interface 16. The received photocurrent from the sensor is provided to an I-V interface 18. The IR and red voltages are then provided to a sigma-delta interface 20 incorporating the present invention. The output of sigma-delta interface 20 is provided to a micro-controller 22 which includes a 10-bit A/D converter. Controller 22 includes flash memory for a program, and EEPROM memory for data. The processor also includes a controller chip 24 connected to a flash memory 26. Finally, a clock 28 is used and an interface 30 to a digital calibration in the sensor 10 is provided. A separate host 32 receives the processed information, as well as receiving an analog signal on a line 34 for providing an analog display.

[0014] LED Drive Circuit

[0015] FIG. 2 is a circuit diagram of the LED drive circuit according to an embodiment of the invention, which forms a portion of LED drive interface 16 of FIG. 1. A voltage regulator 36 provides a voltage separate from the voltage supply for the overall oximeter circuitry. The output is provided as a 4.5 volt signal on line 38, with the level being set by the feedback resistor divider of resistors R89 and R90. The voltage on line 38 is provided to a FET transistor Q11 to an inductor L6. The current through inductor L6 is provided by a switch 40 to one of capacitors C65 and C66, which store charge for the red and IR LEDs, respectively. A red/IR control signal on line 42 selects the switch position under control of the oximeter processor. A control signal LED PWM gate on line 44 controls the switching of transistor switch Q11.

[0016] Once the capacitors are charged up, the control signal on line 44 turns off switch Q11 and current is provided from either capacitor C65 or C66, through switch 40 and inductor L6 to either the red anode line 46 or the IR anode line 48 by way of transistors Q5 and Q6, respectively. A signal "red gate" turns on transistor Q5, while its inverse, "/red gate" turns off transistor Q7. This provides current through the red anode line 46 to the back to back LEDs 50, with the current returning through the IR anode to transistor Q8 and through resistor R10 to ground. Transistor Q8 is

turned on by the signal “/IR gate” while the inverse of this signal, “IR gate” turns off transistor Q6. The signals are reversed when the IR anode is to be driven, with the “IR gate” and “red gate” signals, and their inverses, changing state, so that current is provided through transistor Q6 to IR anode 48 and returns through red anode 46 and through transistor Q7 to resistor R10 and ground. The “LED current sense” signal is read for calibration purposes not relevant to the present invention.

[0017] When the current from the capacitor C65 or C66 is provided through inductor L6 to the LEDs, and that current is switched off at the desired time, transistor Q11 is turned on so that the remaining current during the transition can be dumped into capacitor C64. This addresses the fact that the FET transistor switching is not instantaneous. Subsequently, C64 will dump its current through Q11 and inductor L6 into the capacitors when they are recharged.

[0018] Resistor R38 and capacitor C67 are connected in parallel to inductor L6 to protect against signal spikes, and provide a smooth transition. Connected to inductor L6 is a sampling circuit with a switch 52 controlled by an LED sample hold signal on line 54 to sample the signals and provide them through an amplifier 56 to a “LED current” signal on line 58 which is read by the processor. An integrating capacitor C68 is provided in parallel to amplifier 56. A switch 60 responds to a “clear LED sample” signal to operate the switch to short out the capacitor between samples.

[0019] The sample and hold circuit measures the voltage at node T18, between capacitor C69 and inductor L6, to determine the current. Capacitor C69 is $\frac{1}{4000}$ of the value of capacitors C65 and C66. Thus, a proportional current is provided through C69, which is injected through switch 52 to integrating capacitor C68 to provide a voltage which can be measured at the output of amplifier 56 on line 58. The voltage measured by the processor on line 58 is used as a feedback, with the processor varying the width of the pulse delivered to transistor Q11 to selectively vary the amount of energy that’s delivered to the capacitors 65 and 66, and then is eventually discharged to the LEDs 50. A PI (Proportional Integral) loop inside the processor then controls the PWM signal at Q11. This allows precise control of the LED intensity, allowing it to be maximized, if desired, without exceeding the desired limits (to avoid burning the patient, etc.).

[0020] The lower left of the diagram shows a “4.5 v LED disable” signal which is used by the microprocessor to turn off the voltage regulator 36 in certain instances. For example, diagnostics looking for shorts in a new sensor plugged in will turn off the voltage regulator if there is a problem with the LED line.

[0021] Zero Calibration Control

[0022] FIG. 3 illustrates processor 22, from FIG. 1, connected to programmed logic 62, which is in the LED drive interface 16 in FIG. 1. Programmed logic 62 provides the different control signals used by the circuit of FIG. 2 in response to basic timing signals from the processor of a clock, a sync pulse, and a pulse width signal.

[0023] As can be seen, processor 22 also provides a red zero signal on a line 64 and an IR zero signal on a line 66. These two signals go to programmed logic circuit 62.

Programmed logic 62, in response to assertion of the red zero signal, will provide appropriate control signals on the red gate, /red gate, IR gate and /IR gate control outputs to control the drive transistors in FIG. 2. In particular, assertion of the red zero signal will cause the red gate signal to turn off transistor Q5 and transistor Q8. The programmable logic for switching between the LEDs still functions, but is overridden by this zero signal. Thus, the red gate is held at its value regardless of efforts by the programmable logic state machine to cycle it on and off. Similarly, assertion of the IR zero signal on line 66 will cause program logic circuit 62 to turn off transistor Q6 with the IR gate signal, and turn off transistor Q7 with the /red gate signal.

[0024] These control signals thus assure that current only flows through the red LED or the IR LED, without any leakage due to switching between them while the appropriate red zero or IR zero signal is asserted. This significantly reduces any switching leakage due to use of the duty cycle controls and any capacitively coupled switching transients.

[0025] As will be understood by those of skill in the art, the present invention can be embodied in other specific forms without departing from the essential characteristics thereof. For example, a different drive transistor structure could be used, such as for LEDs that are not configured back-to-back, but rather have separate connections which are separately driven. Accordingly, the foregoing description is intended to be illustrative, but not limiting, of the scope of the invention which is set forth in the following claims.

What is claimed is:

1. A pulse oximeter comprising:

a red drive line for a red light emitting diode (LED);

an infrared (IR) drive line for an IR LED;

a drive circuit coupled to said red and IR drive lines;

a processor for controlling said drive circuit, said processor having a red zero output line and an IR zero output line coupled to said drive circuit, wherein a control signal on said zero output lines turns off a red or IR drive transistor providing forward current flow through said red and IR LEDs, respectively.

2. The pulse oximeter of claim 1 further comprising:

a logic circuit, having inputs connected to said red and IR zero drive lines, and outputs providing control signals to said drive circuit.

3. The pulse oximeter of claim 2 wherein said logic circuit is programmed.

4. The pulse oximeter of claim 2 wherein said red and IR drive transistors comprise red and IR source transistors and red and IR sink transistors in an H-bridge arrangement coupled to a return line from said red and IR LEDs.

5. The pulse oximeter of claim 3 wherein said LEDs are arranged back-to-back, such that said drive line for said red LED is said return line for said IR LED, and said drive line for said IR LED is said return line for said red LED.

6. A pulse oximeter comprising:

a red drive line for a red light emitting diode (LED);

an infrared (IR) drive line for an IR LED;

a drive circuit coupled to said red and IR drive lines;

a logic circuit, having inputs connected to red and IR zero drive lines, and outputs providing control signals to said drive circuit; and

a processor for controlling said programmed logic circuit, said processor being coupled to and driving said red zero output line and said IR zero output line, wherein

a control signal on said zero output lines causes said programmed logic circuit to turn off a red or IR drive transistor providing forward current flow through said red and IR LEDs, respectively.

* * * * *

| | | | |
|----------------|---|---------|------------|
| 专利名称(译) | 血氧计红色和红外零校准控制 | | |
| 公开(公告)号 | US20050187449A1 | 公开(公告)日 | 2005-08-25 |
| 申请号 | US10/788239 | 申请日 | 2004-02-25 |
| [标]申请(专利权)人(译) | 内尔科尔普里坦贝内特公司 | | |
| 申请(专利权)人(译) | NELLCOR PURITAN BENNETT INC. | | |
| 当前申请(专利权)人(译) | COVIDIEN LP | | |
| [标]发明人 | CHEW BRADFORD B PETERSEN ETHAN SHEA WILLIAM | | |
| 发明人 | CHEW, BRADFORD B. PETERSEN, ETHAN SHEA, WILLIAM | | |
| IPC分类号 | A61B5/00 | | |
| CPC分类号 | A61B5/1495 A61B5/14551 | | |
| 其他公开文献 | US7373192 | | |
| 外部链接 | Espacenet USPTO | | |

摘要(译)

带有用于驱动红色和红外LED的驱动线的脉冲血氧计，以及用于驱动这些驱动线的驱动电路。处理器使用红色零输出线和直接连接在处理器和驱动电路之间的IR零输出线来控制驱动电路。这允许控制信号直接控制红色或IR驱动晶体管的关断，以通过超越驱动晶体管的正在进行的可编程逻辑状态机控制来防止正向电流流过红色和IR LED。结果，减少了串扰和电容耦合的影响。

