



US 20050148832A1

(19) **United States**

(12) **Patent Application Publication**  
**Reghabi et al.**

(10) **Pub. No.: US 2005/0148832 A1**

(43) **Pub. Date: Jul. 7, 2005**

(54) **IMPLANTABLE APPARATUS FOR SENSING  
MULTIPLE PARAMETERS**

(22) Filed: **Dec. 26, 2003**

**Publication Classification**

(75) Inventors: **Bahar Reghabi**, Marina Del Rey, CA (US); **Rebecca K. Gottlieb**, Culver City, CA (US); **Rajiv Shah**, Rancho Palos Verdes, CA (US); **Bradley J. Enegren**, Moorpark, CA (US); **William P. Van Antwerp**, Valencia, CA (US)

(51) **Int. Cl.<sup>7</sup>** ..... **A61N 1/30**; A61B 5/00; A61B 5/05

(52) **U.S. Cl.** ..... **600/309**; 604/19; 600/561; 600/549; 600/364; 600/365

(57) **ABSTRACT**

An apparatus for sensing multiple parameters includes an implantable housing and a plurality of implantable sensors disposed within the implantable housing. The plurality of implantable sensors sense parameters in a patient, such as biological or physiological parameters, for example, and each responds to an analyte in the patient. The plurality of implantable sensors may include, but is not limited to, electrochemical, potentiometric, current and optical sensors.

Correspondence Address:  
**FOLEY & LARDNER**  
**2029 CENTURY PARK EAST**  
**SUITE 3500**  
**LOS ANGELES, CA 90067**

(73) Assignee: **Medtronic MiniMed, Inc.**

(21) Appl. No.: **10/746,129**

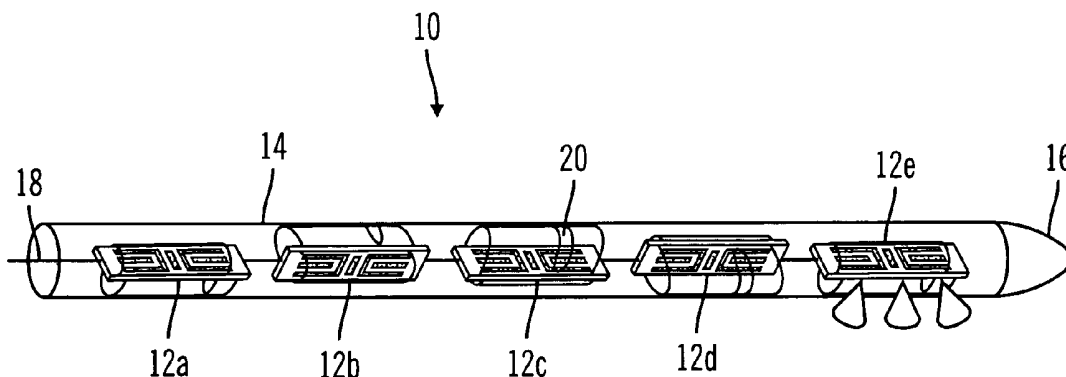

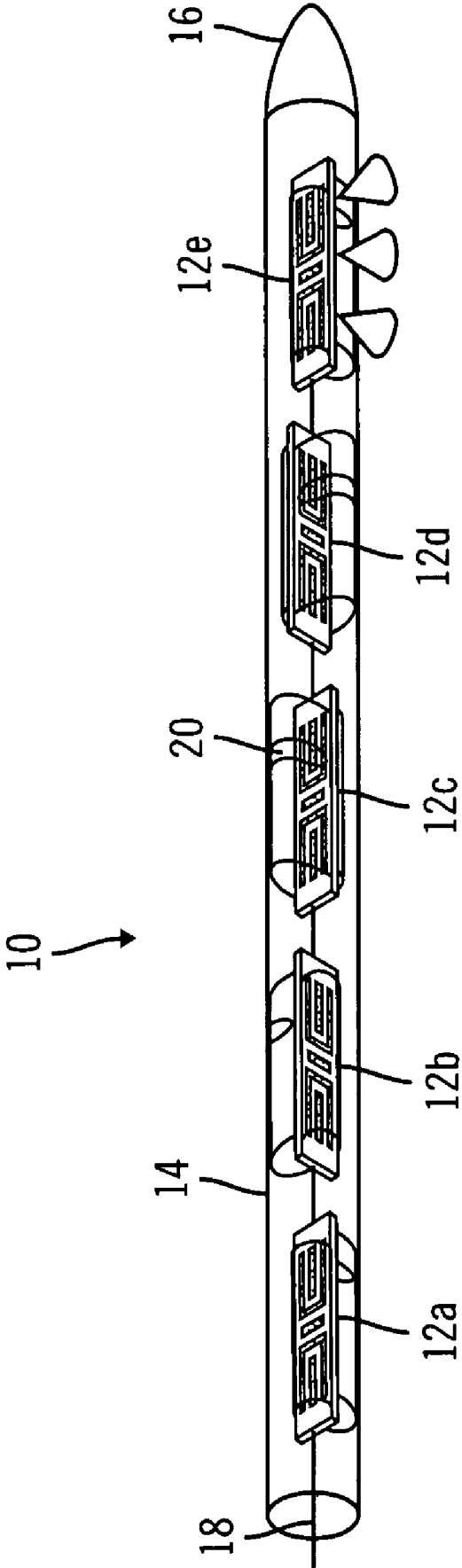

FIG. 1

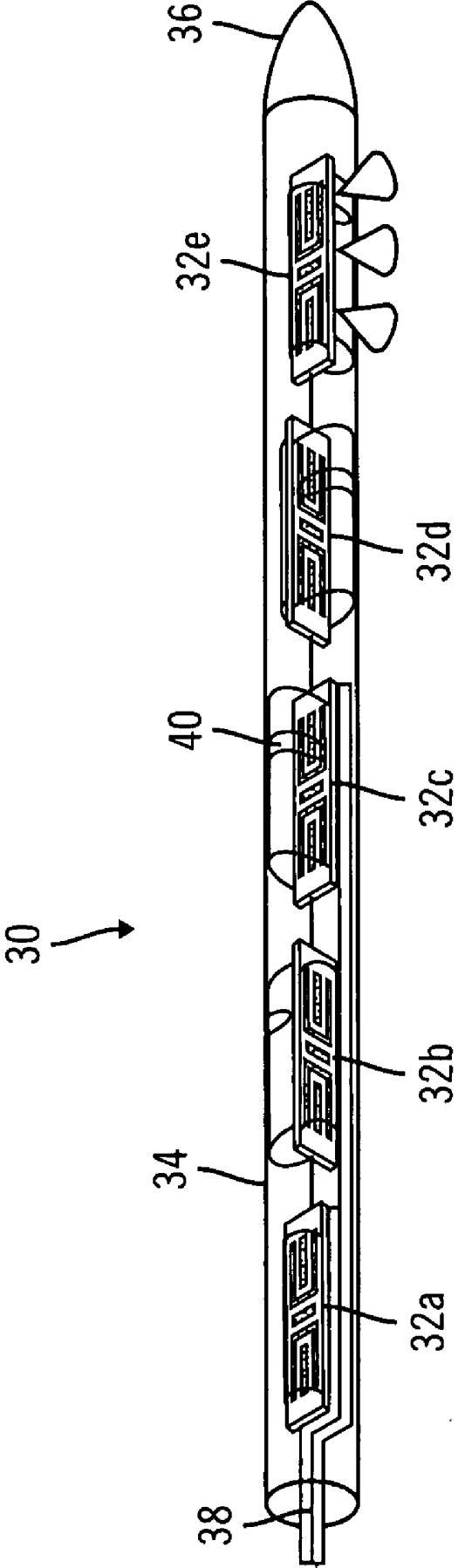

FIG. 2

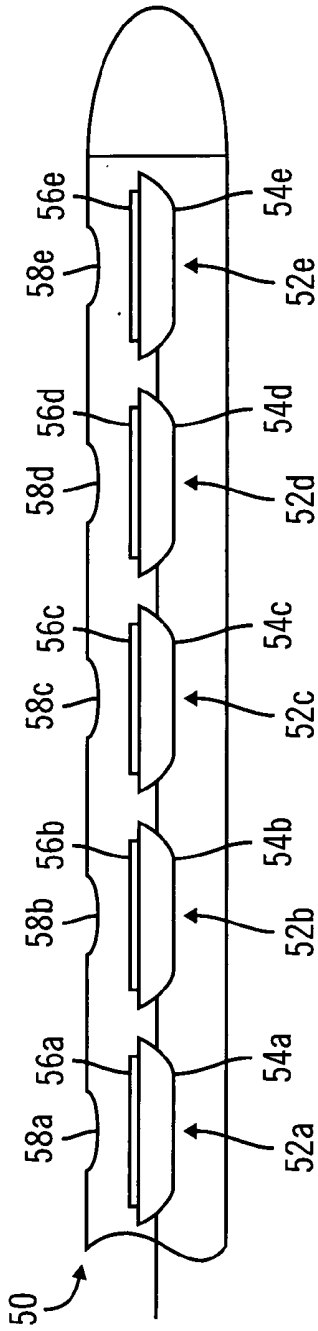

FIG. 3A

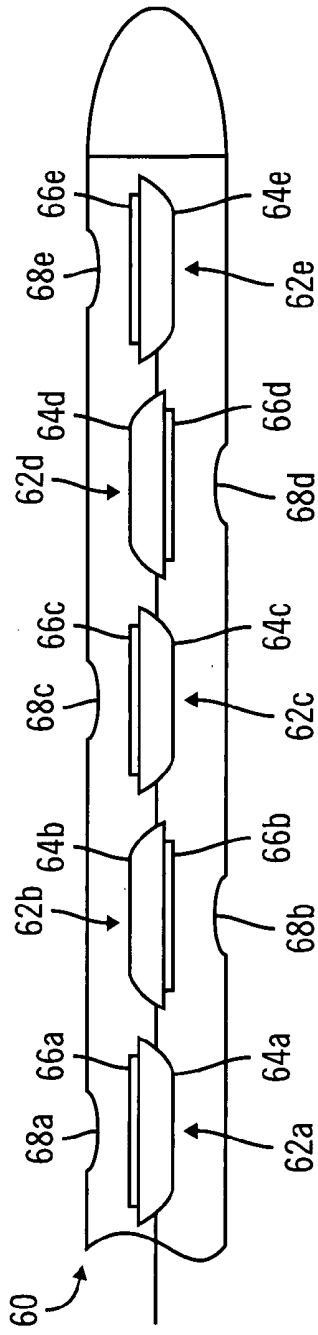

FIG. 3B

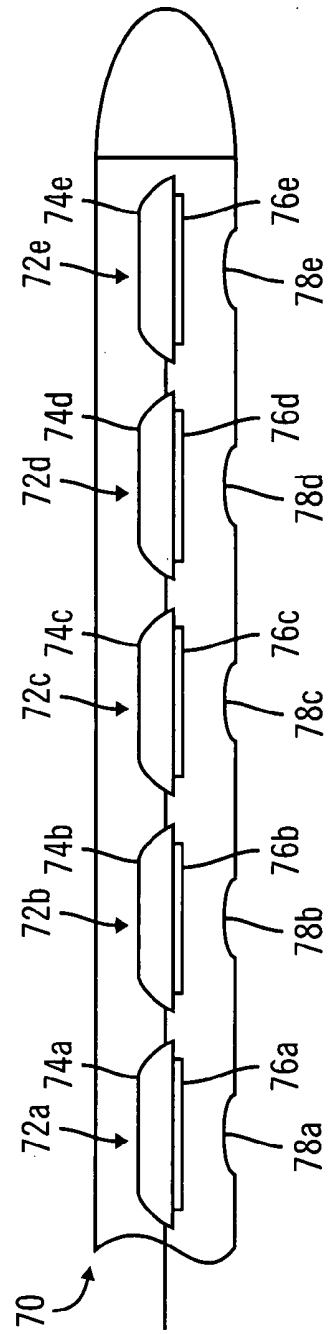

FIG. 3C

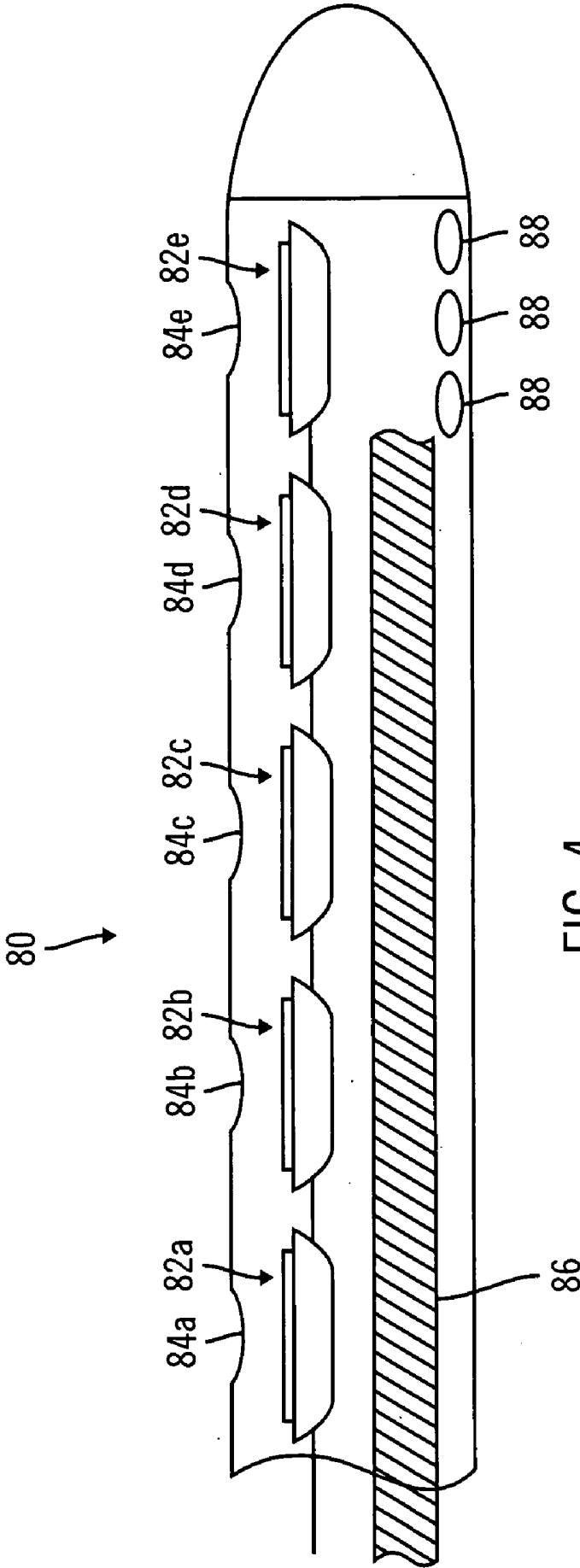

FIG. 4

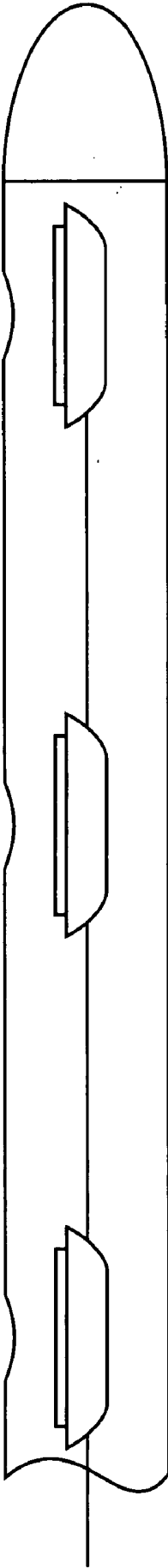

FIG. 5

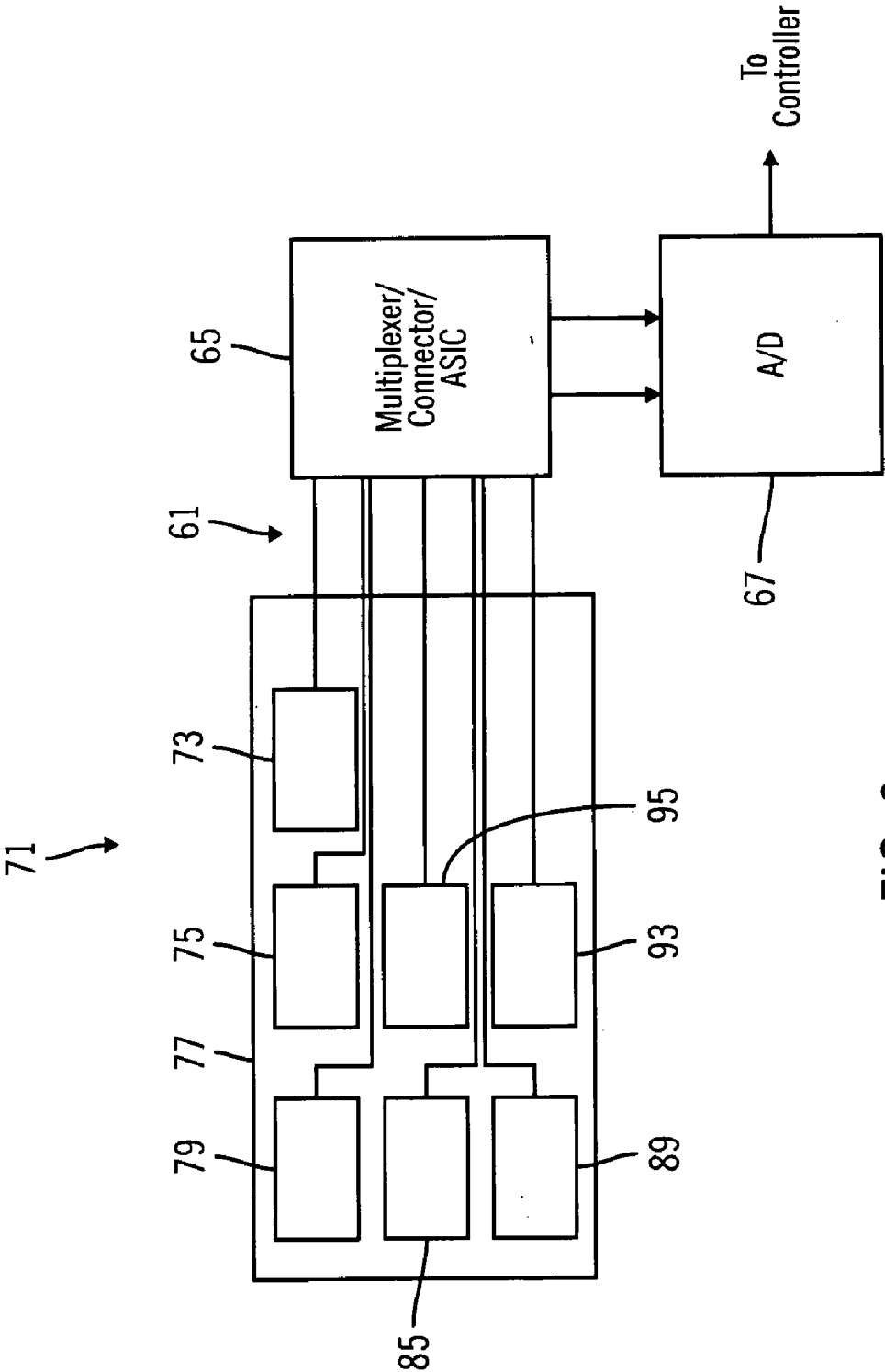

FIG. 6

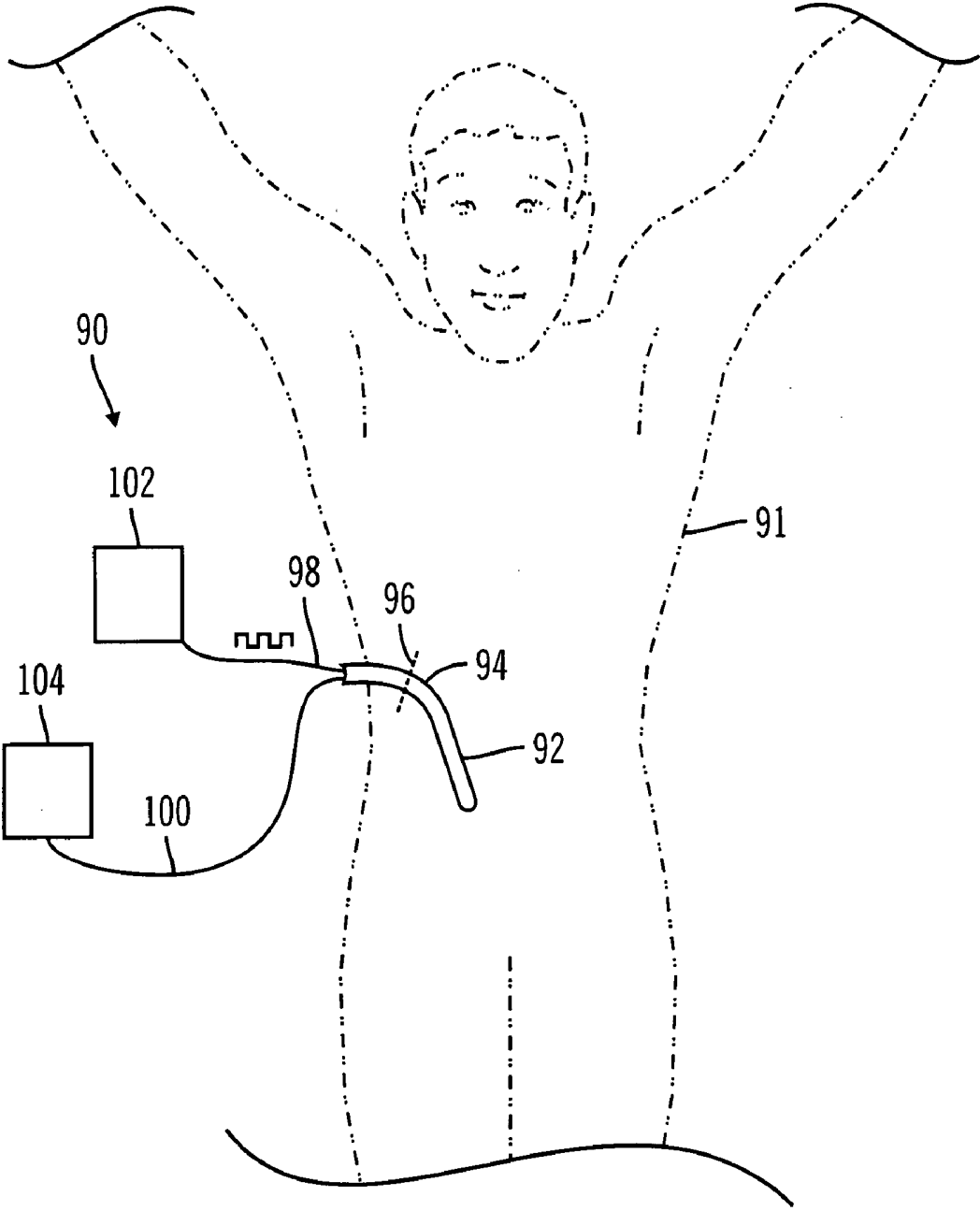

FIG. 7

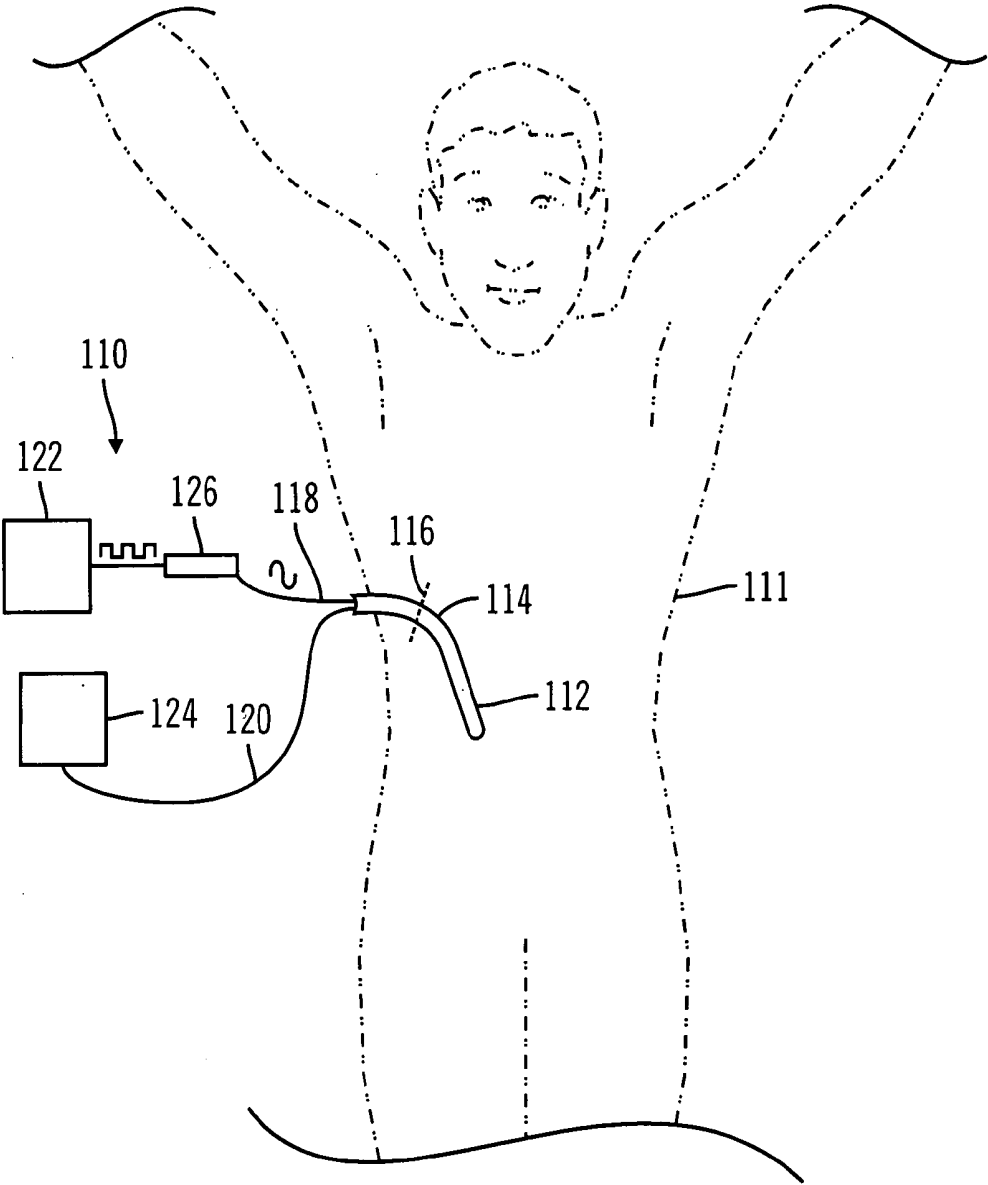

FIG. 8

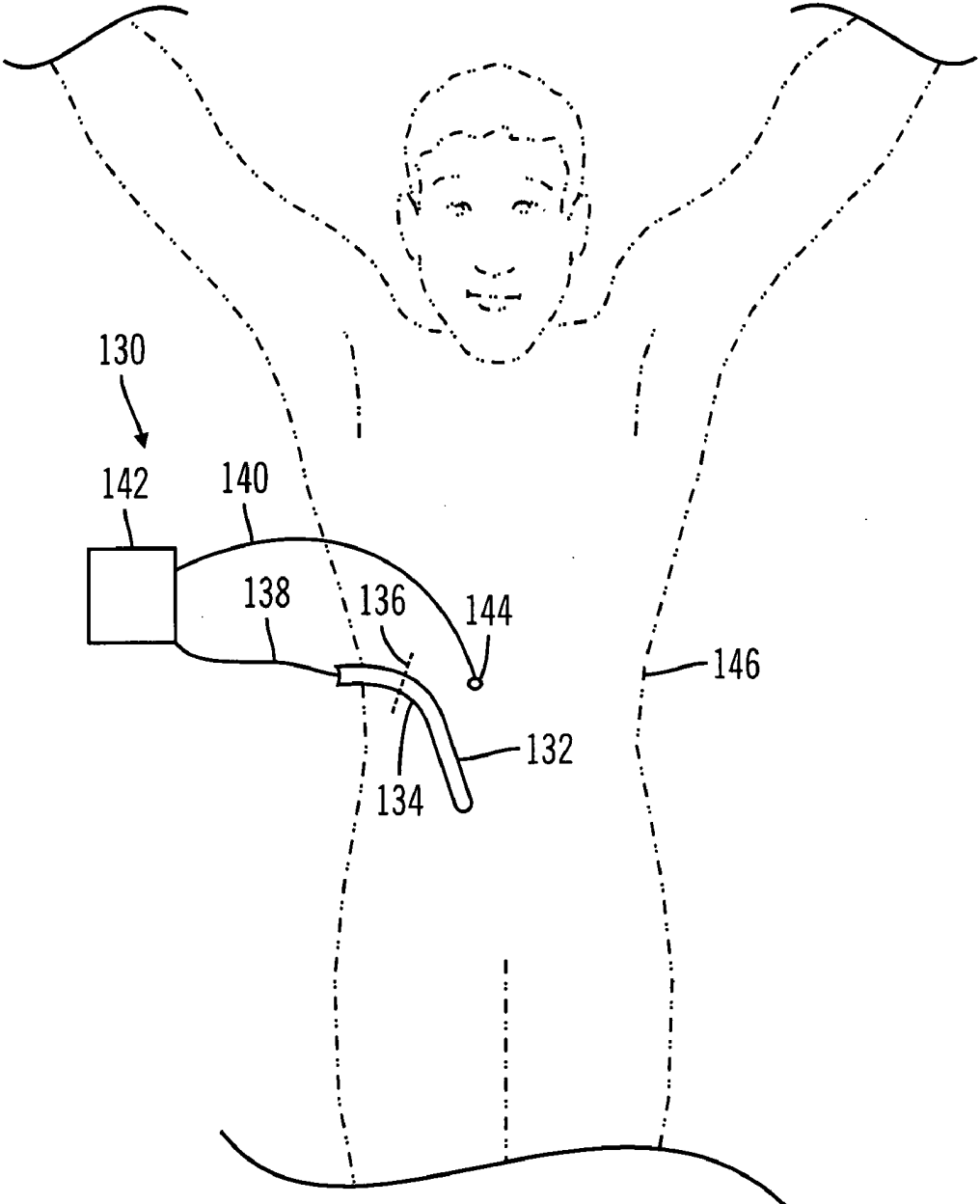

FIG. 9

## IMPLANTABLE APPARATUS FOR SENSING MULTIPLE PARAMETERS

### BACKGROUND

[0001] 1. Field of the Invention

[0002] Embodiments of the present invention relate to biomedical sensor technology and, in particular, to implantable apparatuses for sensing multiple parameters in a patient.

[0003] 2. Description of Related Art

[0004] The ability to monitor biological or physiological parameters, analytes and other parameters in a patient in emergency rooms, intensive care units and other hospital settings is critical in stabilizing patients and reducing mortality rates. The monitoring of blood oxygen saturation, blood pressure, glucose, lactate, temperature, potassium and pH, for example, provides an indication of the state of tissue oxygen balance in the patient, knowledge of which is crucial in preventing a patient from progressing toward a serious, debilitating medical condition or even death.

[0005] Various situations require prompt monitoring and response to a change in body chemistry or other patient parameters. For example, sepsis, a toxic condition resulting from the spread of bacteria or their products from a focus of infection, can lead to global tissue hypoxia, multiple organ failures, cardiovascular collapse and eventual death. Increased blood lactate concentrations and decreased mixed venous oxygen saturation are classic indicators of the early phases of septic shock. By monitoring these parameters, blood chemistry levels can be regulated and the incidence of severe sepsis and septic shock decreased.

[0006] The prevention of severe sepsis and septic shock has become increasingly important. Cases of sepsis occur more frequently in elderly persons than in younger populations. As the number of elderly persons continues to increase, the number of cases of severe sepsis and septic shock can be expected to increase as well.

[0007] Blood glucose is another parameter that requires monitoring in a medical setting in order to maintain proper levels in a patient and reduce mortality rates. For example, for patients who are in an intensive care environment, especially those with diabetes, glucose monitoring is critical. If the amount of glucose in the diabetic patient's system is not maintained at proper levels, the patient may sustain serious or life-threatening injury. If too much glucose accumulates in the diabetic patient's system, the patient could become hyperglycemic, resulting in shortness of breath, nausea and vomiting at best or diabetic coma and death in the worst case. If there is too little glucose in the diabetic patient's system, the patient could become hypoglycemic, resulting in dizziness, sweating and headache at best and unconsciousness and death in the worst case.

[0008] As another example, the medical community has a demonstrated need to understand the local pressure and oxygen, glucose and lactate concentrations in the brain following traumatic injury or stroke. However, typical techniques for measuring pressure and metabolic analytes in the brain requires three catheters and three holes drilled into the cranium to provide pathways for the catheters. One catheter is used to measure pressure, a second catheter is used to measure  $O_2$ , pH and  $pCO_2$ , and a third catheter is a microdi-

alysis catheter used to measure glucose and lactate. Each catheter requires its own control electronics and data monitoring systems. Clearly, a measurement system of this type is cumbersome at best.

[0009] Traditionally, the monitoring of patient parameters in a hospital or other medical setting has been accomplished by drawing a blood sample and sending the sample to a laboratory for analysis. This type of monitoring process, while well-established and providing accurate results, is time-consuming and, indeed, time-prohibitive in an emergency situation. By the time lab results return to an attending physician, the patient may have already entered into a serious state or even have already died.

[0010] Some industry attempts have been made to provide continuous, immediate monitoring of patient parameters. For example, Diametrics Medical, Inc., has developed several sensing systems, such as the NEUROTREND Sensor and the PARATREND7+ Sensors. The NEUROTREND Sensor is a disposable, single-use device for the continuous measurement of intracranial pH,  $pCO_2$ ,  $pO_2$ , and temperature that is used in conjunction with an appropriate intracranial access device. The device incorporates optical sensors for the measurement of pH,  $pCO_2$ , and  $pO_2$ , and a thermocouple for temperature measurement. The NEUROTREND sensor indicates the perfusion and metabolic acidosis/alkalosis status of cerebral tissue in the vicinity of the sensor. The PARATREND7+ Sensors are disposable, single-use fiberoptic devices for continuous measurement of pH,  $pCO_2$ ,  $pO_2$  and temperature, providing real-time oxygenation, ventilation and metabolic information for critically ill patients.

[0011] However, the NEUROTREND Sensors and the PARATREND7+ Sensors have limited capabilities. Optical sensors lose effectiveness quickly when proteins deposit on their surface, which is inevitable in the body. The NEUROTREND Sensors and the PARATREND7+ Sensors, which are based on optical sensors, thus, tend to lose their effectiveness quickly. Accordingly, medical professionals must still use conventional techniques for obtaining reliable, quantifiable parameter values in addition to the values indicated by the NEUROTREND Sensors and the PARATREND7+ Sensors when administering to patients.

[0012] To date, there have been no implantable sensors providing continuous, quantifiable, simultaneous measurement values for patient parameters. In particular, there have been no implantable sensors providing continuous, quantifiable, simultaneous measurement values for lactate, glucose, pH, temperature, venous oxygen pressure, venous oxygen concentration and potassium. An implantable, multi-parameter sensor that monitors one or more of glucose, lactate, pH, temperature, venous oxygen pressure, venous oxygen concentration and blood potassium could be used advantageously in hospital or medical settings, in critical care, emergency care and intensive care situations, in triage, surgery and in field applications. For example, because a patient's blood glucose concentration may increase during kidney dialysis, the monitoring of glucose, oxygen and temperature during dialysis may be helpful.

### SUMMARY

[0013] It is therefore an object of embodiments of the present invention to provide an apparatus for sensing multiple parameters in a patient. It is a further object of

embodiments of the present invention to provide a sensing apparatus that responds to a plurality of analytes simultaneously. It is yet a further object of embodiments of the present invention to provide an apparatus for sensing multiple parameters that can be used in critical care, intensive care or emergency environments. It is yet a further object of embodiments of the present invention to provide an apparatus for sensing multiple parameters that can provide continuous measurement of blood oxygen saturation and lactate.

[0014] An apparatus for sensing multiple parameters may include an implantable housing; an implantable tip affixed to a first end of the housing; and a plurality of implantable sensors disposed within the implantable housing for sensing parameters in a patient. Each of the plurality of implantable sensors may respond to a parameter in the patient.

[0015] At least one of the plurality of implantable sensors may be a biological parameter sensor, a physiological parameter sensor, an electrochemical sensor, a potentiometric sensor, a current sensor or an optical sensor. Also, at least one of the plurality of implantable sensors may produce an analog output or a digital output.

[0016] The plurality of implantable sensors may be wired together in a daisy-chain configuration or may be wired independently from one another. Also, at least two of the plurality of implantable sensors may be wired together in a daisy-chain configuration or may be wired independently from one another.

[0017] At least one of the plurality of implantable sensors may respond to blood oxygen saturation, glucose, lactate, temperature, potassium or pH. At least one of the plurality of implantable sensors may include an electrode. The parameter may be a biological parameter, a physiological parameter or an analyte.

[0018] The tip may be an ogive-shaped tip. The housing may be silicone. The housing may also be a catheter or a multi-lumen catheter. The apparatus may further include an infusion line for delivering an infusant disposed within the implantable housing and adjacent the plurality of sensors.

[0019] An implantable sensor may include an implantable housing; an implantable tip affixed to a first end of the housing; and a plurality of implantable sensing elements disposed within the implantable housing for sensing parameters in a patient. The plurality of implantable sensing elements may be biological parameter sensing elements. The plurality of implantable sensing elements may be physiological parameter sensing elements. The plurality of implantable sensing elements may be analyte sensing elements.

[0020] At least one of the plurality of sensing elements responds to blood oxygen saturation. Also, the sensor may further include an infusion line for delivering an infusant. The infusion line may be disposed within the implantable housing and adjacent the plurality of sensing elements.

[0021] A method of fabricating apparatus for sensing multiple parameters may include providing a plurality of implantable sensors; and enclosing the plurality of implantable sensors in an implantable housing. The plurality of implantable sensors may be biological parameter sensors or physiological parameter sensors. The plurality of implant-

able sensors may be analyte sensors. The method may further include enclosing an infusion line in the implantable housing.

#### BRIEF DESCRIPTION OF THE DRAWINGS

[0022] FIG. 1 shows a perspective view of an apparatus for sensing multiple parameters according to an embodiment of the present invention.

[0023] FIG. 2 shows a perspective view of another apparatus for sensing multiple parameters according to an embodiment of the present invention.

[0024] FIG. 3a shows a cross-sectional view of another apparatus for sensing multiple parameters according to an embodiment of the present invention.

[0025] FIG. 3b shows a cross-sectional view of another apparatus for sensing multiple parameters according to an embodiment of the present invention.

[0026] FIG. 3c shows a cross-sectional view of another apparatus for sensing multiple parameters according to an embodiment of the present invention.

[0027] FIG. 4 shows a cross-sectional view of another apparatus for sensing multiple parameters according to an embodiment of the present invention.

[0028] FIG. 5 shows a cross-sectional view of another apparatus for sensing multiple parameters according to an embodiment of the present invention.

[0029] FIG. 6 shows a block diagram of a sensor system according to an embodiment of the present invention.

[0030] FIG. 7 shows a block diagram of an apparatus for sensing multiple parameters implanted in a patient according to an embodiment of the present invention.

[0031] FIG. 8 shows a block diagram of another apparatus for sensing multiple parameters implanted in a patient according to an embodiment of the present invention.

[0032] FIG. 9 shows a block diagram of another apparatus for sensing multiple parameters implanted in a patient according to an embodiment of the present invention.

#### DETAILED DESCRIPTION

[0033] In the following description of preferred embodiments, reference is made to the accompanying drawings which form a part hereof, and in which are shown by way of illustration specific embodiments in which the invention may be practiced. It is to be understood that other embodiments may be utilized and structural changes may be made without departing from the scope of the preferred embodiments of the present invention.

[0034] Although the following description is directed primarily toward apparatuses for sensing multiple parameters in a patient, embodiments of the present invention may be used in a variety of capacities and applications. For example, embodiments of the present invention may be used for critical care, intensive care or emergency environments. Also, embodiments of the present invention may be used in hospitals to simultaneously measure multiple analytes. Generally, embodiments of the present invention may be adapted for use in any type of medical or hospital situation where

simultaneous measurement of biological or physiological parameters or analytes is desired.

[0035] An apparatus for sensing multiple parameters **10** according to an embodiment of the present invention may be seen in **FIG. 1**. The apparatus for sensing multiple parameters **10** shown in **FIG. 1** includes, but is not limited to, a housing **14**, a plurality of sensors **12a-12e**, a tip **16** and an interconnect **18**. The housing **14** may also include one or more apertures **20** for permitting physical or other contact between fluids in the body and sensing elements located on each of the plurality of sensors **12a-12e**.

[0036] Each of the plurality of sensors **12a-12e** may be designed to sense one or more parameters. For example, each of the plurality of sensors **12a-12e** may be designed to sense a biological or physiological parameter in a patient, such as, for example, blood oxygen saturation, blood pressure, blood temperature, or blood pH. Also, each of the plurality of sensors **12a-12e** may be designed to sense a parameter such as an analyte in a patient, such as, for example, glucose, lactate, or potassium. Accordingly, given the various mechanisms required to sense various parameters, each of the plurality of sensors **12a-12e** may be designed as an electrochemical sensor, a potentiometric sensor, a current sensor, a physical quantity sensor, an optical sensor or other type of sensor, dictated by the parameter being measured.

[0037] Although the embodiment of the present invention shown in **FIG. 1** includes five sensors, embodiments of the present invention may be designed with any number of sensors desired or necessary for a particular application. For example, an embodiment of the present invention shown in **FIG. 5** includes, without limitation, three sensors.

[0038] The plurality of sensors **12a-12e** shown in **FIG. 1** are “daisy-chained” together via the interconnect **18**. Because “daisy-chaining” modules is facilitated by digital addressing, each of the plurality of sensors **12a-12e** shown in the embodiment of **FIG. 1** includes an analog-to-digital (A/D) converter integrated circuit as well as a power supply for powering the integrated circuit, such as, for example, a capacitor. Thus, because each of the plurality of sensors **12a-12e** includes an onboard A/D, the information leaving the housing **14** on the interconnect **18** is in digital form.

[0039] Also, each of the plurality of sensors **12a-12e** may be individually addressed by a remote device, such as, for example, a computer or other controller. The addressing schemes may be any scheme common in the industry and may include, without limitation, various modulation schemes such as frequency modulation or time modulation schemes, for example.

[0040] The housing **14** may be fabricated in a variety of ways. For example, the housing **14** may be a single, standard catheter that is flexible for vascular placement. If the housing **14** is a flexible catheter, the apparatus for sensing multiple parameters **10** may be placed independently in the body. In addition, the housing **14** may be one lumen of a multi-lumen catheter or may be part of a central venous line or sheath. According to an embodiment of the present invention, the housing **14** may be made of silicone or a polyethylene, for example.

[0041] According to an embodiment of the present invention, the tip **16** may be an ogive shape, i.e., a “bullet nose.”

An ogive-shaped tip **16** may optimize a flow field around the apparatus for sensing multiple parameters **10** and, being curved, may be less likely to gouge the patient during insertion. According to another embodiment of the present invention, the tip **16** may have some sort of structure, such as, for example, a screw anchor or other structure, allowing it to be fixed into tissue.

[0042] **FIG. 2** shows an apparatus for sensing multiple parameters **30** according to another embodiment of the present invention. The apparatus for sensing multiple parameters **30** includes, but is not limited to, a plurality of sensors **32a-32e**, a housing **34**, a tip **36** and an interconnect **38**. The housing **34** may also include one or more apertures **40** allowing fluids in the body to come into physical contact with the sensors **32a-32e**.

[0043] Whereas each of the plurality of sensors **12a-12e** of **FIG. 1** were daisy-chained together, the plurality of sensors **32a-32e** in **FIG. 2** operate independently of one another and are individually wired. In other words, according to the embodiment of the present invention shown in **FIG. 2**, each of the plurality of sensors **32a-32e** has a wire connected to it that is routed out of the housing **34** such that the interconnect **38** is actually a plurality of interconnects. Because there is no daisy-chain configuration in the embodiment of the invention shown in **FIG. 2**, there is no need for each of the plurality of sensors **32a-32e** to be digitally addressable. Each of the plurality of sensors **32a-32e** may transmit or receive an analog signal; there is no requirement to include an onboard A/D integrated circuit and associated power supply. Without the A/D integrated circuit and associated power supply, the “wired” sensing apparatus **30** according to the embodiment of the present invention shown in **FIG. 2** may have a reduced size, making it flexible and desirable for medical and/or surgical use.

[0044] Embodiments of the present invention need not be limited to a “daisy-chained” sensing apparatus as shown in **FIG. 1** or a “wired” sensing apparatus as shown in **FIG. 2**. Embodiments of the present invention may also include, without limitation, a combination of daisy-chained and wired configurations.

[0045] The sensors **12a-12e** and **32a-32e** shown in the embodiments of the invention of **FIG. 1** and **FIG. 2** may be physically disposed in a variety of ways. For example, the plurality of sensors **12a-12e** shown in **FIG. 1** and the plurality of sensors **32a-32e** shown in **FIG. 2** are arranged in a “perpendicular” fashion. In other words, in the embodiments of the invention shown in **FIGS. 1 and 2**, each sensor is aligned perpendicularly or is “on its side” relative to the sensor adjacent to it. Thus, according to embodiments of the present invention, flexibility in position and/or orientation may be achieved. For example, according to embodiments of the present invention, a drug may be dosed in a perpendicular fashion on one half of the catheter while a parameter may be measured on another half of the catheter. Also, in embodiments of the invention in which all sensing elements are disposed on one side of the catheter, for example, the catheter may be rotated or positioned in multiple orientations to determine a variance in readings for a particular environment, thus indicating whether an environment is “well-mixed.”

[0046] **FIG. 3A** shows another embodiment of the present invention having a plurality of sensors **52a-52e** all aligned in

a first orientation. In the embodiment of the invention shown in FIG. 3A, all sensor substrates 54a-54e face in the same direction. Likewise, all sensing elements 56a-56e also face in the same direction. To accommodate the sensing elements 56a-56e, the housing of the apparatus for sensing multiple parameters 50 may also include apertures 58a-58e which allow fluids to make physical contact with the sensing elements 56a-56e.

[0047] The physical placement of sensors according to another embodiment of the present invention may be seen in FIG. 3B. In FIG. 3B, an apparatus for sensing multiple parameters 60 includes, but is not limited to, a plurality of sensors 62a-62e. Sensor substrates 64a, 64c, and 64e face in a direction opposite that of sensor substrates 64b and 64d. Likewise, a first sensing element 66a, a second sensing element 66c and a third sensing element 66e face in a direction opposite that of a fourth sensing element 66b and a fifth sensing element 66d. The housing of the apparatus for sensing multiple parameters 60 may include apertures 68a-66e which allow fluids to make physical contact with the sensing elements 66a-66e.

[0048] FIG. 3C shows sensing elements aligned in another configuration according to an embodiment of present the invention. In FIG. 3C, each of the plurality of sensors 72a-72e are aligned in the same direction. However, each of the sensors 72a-72e are aligned in a direction opposite the sensors 52a-52e shown in FIG. 3A. Also, in the embodiment of the invention shown in FIG. 3C, the apparatus for sensing multiple parameters 70 includes apertures 78a-78e which allow fluids to make physical contact with the sensing elements 76a-76e.

[0049] An apparatus for sensing multiple parameters 80 according to yet another embodiment of present the present invention is shown in FIG. 4. The apparatus for sensing multiple parameters 80 includes, but is not limited to, a plurality of sensors 82a-82e, a plurality of sensor apertures 84a-84e, an infusion line 86 and infusion apertures 88. The apparatus for sensing multiple parameters 80 also includes a housing 81 and a tip 83.

[0050] In the embodiment of the invention shown in FIG. 4, the infusion line 86 allows an infusant, drug or other medicant to be delivered to a patient through the infusion apertures 88. Thus, if an analyte sensed by the sensors 82a-82e indicates that it would be advantageous for a patient to be treated with an infusant, the infusant may be delivered directly through the infusion line 86 and through the infusion apertures 88 to the patient. The apparatus for sensing multiple parameters 80 according to the embodiment of the invention shown in FIG. 4 eliminates the need to insert an additional catheter into the patient for delivery of an infusant.

[0051] According to embodiments of the present invention, the sensors used for sensing parameters in a patient, such as, for example, sensors 12a-12e shown in FIG. 1, may sense one or more biological or physiological parameters or one or more analytes. For example, referring back to FIG. 1, the first sensor 12A may be a glucose sensor using a glucose oxidase enzyme capable of measuring glucose and oxygen concentration. The first sensor 12a may be an electrochemical sensor. A sensor of this type is disclosed in a patent application entitled "Sensing Apparatus and Process," Ser. No. 10/036,093, filed Dec. 28, 2001, the contents

of which are hereby incorporated by reference herein. A substrate that may be used for the first sensor 12A is disclosed in a patent application entitled "Sensor Substrate and Method of Fabricating Same," Ser. No. 10/038,276, filed Dec. 28, 2001, the contents of which are hereby incorporated by reference herein. The first sensor 12a may also include a thermistor for measuring temperature.

[0052] The second sensor 12b shown in FIG. 1 may be designed to sense lactate, temperature and oxygen pressure. The second sensor 12b may be an electrochemical sensor. The second sensor 12b may be a modification of the first sensor 12a. For example, according to an embodiment of the present invention, if the first sensor 12a uses a glucose oxidase enzyme to effect glucose measurements, the second sensor 12b may use a similar sensor and replace the glucose oxidase enzyme with a lactose oxidase enzyme to effect lactate measurements.

[0053] The third sensor 12c shown in FIG. 1 may be designed to sense potassium while the fourth sensor 12d shown in FIG. 1 may be designed to sense pH. The third sensor 12c and the fourth sensor 12d may be potentiometric sensor.

[0054] Oxygen saturation may be derived from other parameters, such as pH, pO<sub>2</sub> and temperature, for example, or may be measured directly. The fifth sensor 12e shown in FIG. 1 may be designed as an oximeter and may be capable of measuring oxygen saturation levels. Thus, the fifth sensor 12e may be an optical sensor or a pulse oximeter (SvO<sub>2</sub> or SpO<sub>2</sub>). According to another embodiment of the present invention, the fifth sensor 12e may be a co-oximeter. A co-oximeter may be used in direct contact with the blood. A co-oximeter may utilize four wavelengths of light to separate oxyhemoglobin from reduced hemoglobin, methemoglobin (MetHb) and carboxyhemoglobin (COHb). Pulse oximeters may measure COHb and part of any MetHb along with oxyhemoglobin measurements. A substrate for a sensor may be designed to effect a co-oximeter. For example, the substrate disclosed in the patent application entitled "Sensor Substrate and Method of Fabricating Same," Ser. No. 10/038,276, may be modified such that it can accommodate measuring four wavelengths of light. Four vias of the substrate may be fabricated using glass, polycarbonate, or any other material that can pass the desired wavelengths, each via being capable of passing one wavelength.

[0055] The sensor may also be fabricated with a light-emitting diode (LED) designed into it. By incorporating an LED into the sensor, blood oxygen saturation may be determined by monitoring the various wavelengths reflected from the blood using light emanating from the LED, which vary depending on the hemoglobin concentration of the blood.

[0056] The sensors may also be designed to measure physical characteristics. For example, the sensors may be designed to measure pressure, acceleration or other physical characteristics.

[0057] According to embodiments of the present invention, the sensors shown in FIGS. 1-5 may be used in any order. For example, although the sensors 12a-12e shown in FIG. 1 may be a glucose/pO<sub>2</sub>/temperature sensor; a lactate/pO<sub>2</sub>/temperature sensor; a pH sensor; a potassium sensor; and an SvO<sub>2</sub> sensor, respectively, the order of the sensors

12a-12e may vary. Thus, each of the sensors may occupy any location within the interior of the housing 14.

[0058] FIG. 6 shows an embodiment of a sensor system 71 that may be used in conjunction with embodiments of the present invention. The embodiment of the invention shown in FIG. 6 includes, but is not limited to, an electrode array 77, a multiplexer/controller/ASIC 65 and a digitizer or A/D 67. The electrode array 77 in the embodiment of the invention shown in FIG. 6 includes, without limitation, a glucose electrode 79, a lactate electrode 85, an oxygen electrode 89, a reference electrode 75, an enzyme counter electrode 95, an oxygen counter electrode 93 and a pressure transducer 73. However, embodiments of the present invention are not limited to the electrode array 77 or the pressure transducer 73 shown and other embodiments of the invention may include other electrodes and other transducers.

[0059] The electrode array 77 may be fabricated in a variety of ways. For example, according to one embodiment of the present invention, the electrode array 77 may be fabricated onto a standard silicon chip. The chip may have a width of approximately 700 microns and a length of approximately 6 cm. The chip may be fabricated by first depositing a metalization layer (e.g., chrome/gold/chrome) onto a silicon substrate. Next, the electrode array 77 and interconnects 61 for the glucose electrode 79, lactate electrode 85, oxygen electrode 89, reference electrode 75, enzyme counter electrode 95 and oxygen counter electrode 93 may then be defined and patterned using standard photoresist/stripping etching technology.

[0060] After the electrode array 77 and interconnects 61 have been defined and patterned, windows for the electrodes and insulation may then be defined and patterned using a photoimageable polyamide system. The pressure transducer 73 may be fabricated by micromachining a CMOS portion of a wafer using standard dry etch technology or other standard techniques. By monitoring a difference in capacitance between the CMOS portion and an offset reference pad and a thin, rigid silicon top member and the offset reference pad, local pressure may be determined. The rigid silicon top member may be implemented by any of a variety of methods that are well-known in the art.

[0061] The ASIC portion of the multiplexer/controller/ASIC 65 controls three potentiostat circuits, one for measuring oxygen by reduction electrochemistry, one to measure glucose by measuring hydrogen peroxide produced by glucose oxidase on the glucose electrode (i.e., by measuring the oxidation of  $H_2O_2$ ), and one to measuring  $H_2O_2$  made by lactose oxidase on the lactate sensor. The pressure transducer circuit measures a change in capacitance as the pressure of the cranial tissue increases.

[0062] According to another embodiment of the present invention, the sensor system 71 of FIG. 6 may be implemented using a single potentiostat in pulse mode to differentially and singly interrogate the oxygen, glucose and lactate sensors using chronoamperometry. This embodiment allows for a simplification of the associated electronic circuitry. In addition, this embodiment may display temporal data in real time for all analytes. Moreover, the electrode array may easily be extended to include other electrochemically measurable analytes, such as, for example, pyruvate, pH,  $CO_2$ , and electrochemically measurable neurotransmitters such as dopamine, for example.

[0063] A block diagram of a multi-parameter sensing system 90 with a multi-parameter sensor implanted in a patient may be seen in FIG. 7. In FIG. 7, an apparatus for sensing multiple parameters 92 is inserted into a patient 91. A catheter portion 94 of the apparatus for sensing multiple parameters 92 exits the patient 91 at an incision 96 and extends out of the patient 91. If the apparatus for sensing multiple parameters 92 shown in FIG. 7 is a daisy-chained apparatus, the information present on the interconnect 98 may be in digital form and may be connected directly to a computer 102 or other analytical device. The apparatus for sensing multiple parameters 92 in FIG. 7 may also include an infusion line 100 which may be connected to an infusant delivery system 104 or other delivery system.

[0064] A block diagram of a multi-parameter sensing system 110 according to another embodiment of present the present invention may be seen in FIG. 8. In FIG. 8, an apparatus for sensing multiple parameters 112 is implanted in a patient 111. A catheter portion 114 of the apparatus for sensing multiple parameters 112 exits the patient 111 at an incision 116 and extends out of the patient 111. In the embodiment of the invention shown in FIG. 8, if the apparatus for sensing multiple parameters 112 is a "wired" sensing apparatus, the information contained on the interconnect 118 may be in analog form. The interconnect 118, which may be a plurality of interconnects, may be connected to an analog-to-digital converter (A/D) 126. The information coming out of the A/D 126 is in digital form and may be connected to a computer 122 or other analytical device. According to another embodiment of the present invention, the information contained on the interconnect 118, being in analog form, may also be connected directly to an oscilloscope or other analytical device. The multi-parameter sensing system 110 may also include an infusion line 120 which may be connected to an infusant delivery system 124.

[0065] A block diagram of a multi-parameter sensing system 130 according to another embodiment of present the present invention may be seen in FIG. 9. In FIG. 9, an apparatus for sensing multiple parameters 132 is implanted in a patient 146. A catheter portion 134 of the apparatus for sensing multiple parameters 132 exits the patient 146 at an incision 136 and extends out of the patient 146. In the embodiment of the invention shown in FIG. 9, one of the sensors in the apparatus for sensing multiple parameters 132 includes an internal electrode which cooperates with an external electrode 144. An first interconnect 138, which includes a signal from the internal electrode on one of the sensors in the apparatus for sensing multiple parameters 132, and a second interconnect 140 are connected to a computer or other controller/analyzer 142. The computer or other controller/analyzer 142 is able to sense a change of impedance between the internal electrode on one of the sensors in the apparatus for sensing multiple parameters 132 and the external electrode 144, corresponding to a change in the chemical, biological or physiological make-up of the area between the two electrodes, i.e., the patient.

[0066] For example, if a patient enters a state of edema, an increase in fluid in body tissue, the embodiment of the present invention shown in FIG. 9 could be used to detect the edema. An increase in fluid in body tissue may correspond to a change in the impedance of the body tissue, which would be sensed by the internal electrode and the external electrode 144.

[0067] Embodiments of the present invention may be advantageously used in a variety of ways. For example, severe sepsis and septic shock may be mitigated by using embodiments of the present invention. Severe sepsis and septic shock may be mitigated by continuously monitoring lactate levels in a patient. The concentration of lactate in the blood increases as a patient enters a septic phase. In addition, the concentration of blood potassium typically lowers as a patient enters a septic phase while central venous pressure drops. Also, according to some schools of thought, venous O<sub>2</sub> can rise as a patient becomes septic or is going through sepsis. Thus, embodiments of the present invention may be used to continuously monitor blood lactate, venous O<sub>2</sub>, potassium and central venous pressure, thereby allowing a physician or other medical attendant to administer to the patient responsive treatment based on the monitored parameters and prevent the patient from becoming septic.

[0068] Embodiments of the present invention may also be used to maintain proper insulin levels, especially in diabetics. For example, according to an embodiment of the present invention, blood glucose may be monitored and insulin levels adjusted accordingly to prevent a patient from becoming hypoglycemic or hyperglycemic. Along with glucose, O<sub>2</sub> and temperature measurements may be made to assist the medical professional in determining the most advantageous time and manner to adjust the patient's insulin to the proper levels.

[0069] Embodiments of the present invention allow medical professionals to use one sensing apparatus to measure multiple parameters. As has been shown, a single sensing apparatus may be implanted at a single site in a patient. Moreover, a plurality of parameters may be read from the single apparatus implanted at the single site in the patient. Thus, the medical and surgical risks involved by placing multiple devices or sensors on a patient to measure desired parameters are reduced.

[0070] Embodiments of the present invention may be used in vascular or non-vascular applications. For example, sensors according to embodiments of the present invention be inserted into the vasculature. According to other embodiments of the present invention, sensors may be positioned in the peritoneal or may be positioned subcutaneously. Embodiments of the present invention may also be used for intracranial and defibrillation applications.

[0071] While particular embodiments of the present invention have been shown and described, it will be obvious to those skilled in the art that the invention is not limited to the particular embodiments shown and described and that changes and modifications may be made without departing from the spirit and scope of the appended claims.

What is claimed is:

1. An apparatus for sensing multiple parameters comprising:

an implantable housing;

an implantable tip affixed to a first end of the housing; and

a plurality of implantable sensors disposed within the implantable housing for sensing parameters in a patient,

wherein at least one of the plurality of implantable sensors responds to lactate.

2. The apparatus for sensing multiple parameters of claim 1, wherein at least one of the plurality of implantable sensors is a biological parameter sensor.

3. The apparatus for sensing multiple parameters of claim 1, wherein at least one of the plurality of implantable sensors is a physiological parameter sensor.

4. The apparatus for sensing multiple parameters of claim 1, wherein at least one of the plurality of implantable sensors is an electrochemical sensor.

5. The apparatus for sensing multiple parameters of claim 1, wherein at least one of the plurality of implantable sensors is a potentiometric sensor.

6. The apparatus for sensing multiple parameters of claim 1, wherein at least one of the plurality of implantable sensors is a current sensor.

7. The apparatus for sensing multiple parameters of claim 1, wherein at least one of the plurality of implantable sensors is an optical sensor.

8. The apparatus for sensing multiple parameters of claim 1, wherein at least one of the plurality of implantable sensors produces an analog output.

9. The apparatus for sensing multiple parameters of claim 1, wherein at least one of the plurality of implantable sensors produces a digital output.

10. The apparatus for sensing multiple parameters of claim 1, wherein the plurality of implantable sensors are wired together in a daisy-chain configuration.

11. The apparatus for sensing multiple parameters of claim 1, wherein the plurality of implantable sensors are wired independently from one another.

12. The apparatus for sensing multiple parameters of claim 1, wherein at least two of the plurality of implantable sensors are wired together in a daisy-chain configuration.

13. The apparatus for sensing multiple parameters of claim 1, wherein at least two of the plurality of implantable sensors are wired independently from one another.

14. The apparatus for sensing multiple parameters of claim 1, wherein at least one of the plurality of implantable sensors responds to blood oxygen saturation.

15. The apparatus for sensing multiple parameters of claim 1, wherein at least one of the plurality of implantable sensors responds to glucose.

16. The apparatus for sensing multiple parameters of claim 1, wherein the at least one of the plurality of implantable sensors that responds to lactate responds to lactate continuously.

17. The apparatus for sensing multiple parameters of claim 1, wherein at least one of the plurality of implantable sensors responds to temperature.

18. The apparatus for sensing multiple parameters of claim 1, wherein at least one of the plurality of implantable sensors responds to potassium.

19. The apparatus for sensing multiple parameters of claim 1, wherein at least one of the plurality of implantable sensors responds to pH.

20. The apparatus for sensing multiple parameters of claim 1, wherein at least one of the plurality of implantable sensors includes an electrode.

21. The apparatus for sensing multiple parameters of claim 1, wherein the parameter is a biological parameter.

22. The apparatus for sensing multiple parameters of claim 1, wherein the parameter is a physiological parameter.

23. The apparatus for sensing multiple parameters of claim 1, wherein the parameter is an analyte.

24. The apparatus for sensing multiple parameters of claim 1, wherein the tip is an ogive-shaped tip.

25. The apparatus for sensing multiple parameters of claim 1, wherein the housing is silicone.

26. The apparatus for sensing multiple parameters of claim 1, wherein the housing is a catheter.

27. The apparatus for sensing multiple parameters of claim 1, wherein the housing is a multi-lumen catheter.

28. The apparatus for sensing multiple parameters of claim 1, further comprising an infusion line for delivering an infusant, the infusion line being disposed within the implantable housing and adjacent the plurality of sensors.

29. An implantable sensor comprising:

an implantable housing;

an implantable tip affixed to a first end of the housing; and

a plurality of implantable sensing elements disposed within the implantable housing for sensing parameters in a patient.

30. The sensor of claim 29, wherein the plurality of implantable sensing elements are biological parameter sensing elements.

31. The sensor of claim 29, wherein the plurality of implantable sensing elements are physiological parameter sensing elements.

32. The sensor of claim 29, wherein the plurality of implantable sensing elements are analyte sensing elements.

33. The sensor of claim 29, wherein at least one of the plurality of sensing elements responds to blood oxygen saturation.

34. The sensor of claim 29, further comprising an infusion line for delivering an infusant, the infusion line being disposed within the implantable housing and adjacent the plurality of sensing elements.

35. The sensor of claim 29, wherein the plurality of implantable sensing elements are electrodes disposed on a substrate.

36. The sensor of claim 35, wherein one of the electrodes is a glucose electrode.

37. The sensor of claim 35, wherein one of the electrodes is a lactate electrode.

38. The sensor of claim 35, wherein one of the electrodes is an oxygen electrode.

39. The sensor of claim 35, wherein one of the electrodes is a reference electrode.

40. The sensor of claim 35, wherein one of the electrodes is an enzyme counter. electrode.

41. The sensor of claim 35, wherein one of the electrodes is an oxygen counter electrode.

42. The sensor of claim 29, wherein the plurality of implantable sensing elements includes a pressure transducer.

43. The sensor of claim 29, wherein the plurality of implantable sensing elements sense intracranial parameters.

44. A method of fabricating an apparatus for sensing multiple parameters comprising:

providing a plurality of implantable sensors; and

enclosing the plurality of implantable sensors in an implantable housing.

45. The method of claim 44, wherein the plurality of implantable sensors are biological parameter sensors.

46. The method of claim 44, wherein the plurality of implantable sensors are physiological parameter sensors.

47. The method of claim 44, wherein the plurality of implantable sensors are analyte sensors.

48. The method of claim 44, further comprising enclosing an infusion line in the implantable housing.

\* \* \* \* \*

专利名称(译)	用于感测多个参数的可植入设备		
公开(公告)号	<a href="#">US20050148832A1</a>	公开(公告)日	2005-07-07
申请号	US10/746129	申请日	2003-12-26
[标]申请(专利权)人(译)	美敦力迷你迈德公司		
申请(专利权)人(译)	MEDTRONIC MINIMED INC.		
当前申请(专利权)人(译)	MEDTRONIC MINIMED INC.		
[标]发明人	REGHABI BAHAR GOTTLIEB REBECCA K SHAH RAJIV ENEGREN BRADLEY J VAN ANTWERP WILLIAM P		
发明人	REGHABI, BAHAR GOTTLIEB, REBECCA K. SHAH, RAJIV ENEGREN, BRADLEY J. VAN ANTWERP, WILLIAM P.		
IPC分类号	A61B5/00 A61B5/0215 A61N1/30 A61B5/05		
CPC分类号	A61B5/01 A61B5/0215 A61B5/14532 A61B5/14539 A61B5/14542 A61B5/14546 A61B2562/063 A61B5/1459 A61B5/14865 A61B5/412 A61B5/4839 A61B5/6852 A61B5/14551		
其他公开文献	US8948836		
外部链接	<a href="#">Espacenet</a> <a href="#">USPTO</a>		

摘要(译)

一种用于感测多个参数的装置包括可植入壳体 and 设置在可植入壳体内的多个可植入传感器。多个可植入传感器感测患者中的参数，例如生物或生理参数，并且每个参数响应患者中的分析物。多个可植入传感器可包括但不限于电化学，电位，电流和光学传感器。

