



(19) **United States**

(12) **Patent Application Publication**
Halleck et al.

(10) **Pub. No.: US 2005/0065457 A1**
(43) **Pub. Date: Mar. 24, 2005**

(54) **SYSTEM AND METHOD FOR REMOTELY MONITORING AT LEAST ONE PHYSIOLOGICAL CHARACTERISTIC OF A CHILD**

Publication Classification

(51) **Int. Cl.⁷** **A61B 7/00**
(52) **U.S. Cl.** **600/586**

(75) **Inventors: Michael E. Halleck**, Longmont, CO (US); **Michael D. Halleck**, Northglenn, CO (US); **Michael L. Lehrman**, Washington, DC (US)

(57) **ABSTRACT**

There is disclosed a system and method for remotely monitoring at least one physiological condition of a child by detecting very low frequency acoustic signals. The apparatus comprises a sensor that is capable of detecting low frequency acoustic signals in the frequency range of one tenth Hertz to thirty Hertz. The sensor comprises a chamber having portions that form a cavity and a low frequency microphone placed within the cavity. An alternate embodiment of the invention comprises a chamber having portions that form a resonant cavity, a microphone mounted in the resonant cavity, and a membrane that covers the resonant cavity. Low frequency acoustic signals that are incident on the membrane cause the membrane to move and amplify the acoustic signals within the resonant cavity. The sensor provides information concerning physiological conditions of the child, such as respiration and cardiac activity. The sensor in a physiological condition monitor does not need to be directly coupled to the skin of the child being monitored.

Correspondence Address:
DOCKET CLERK
P.O. DRAWER 800889
DALLAS, TX 75380 (US)

(73) **Assignee: CARING TECHNOLOGIES, INC.**,
Dallas, TX

(21) **Appl. No.: 10/801,108**

(22) **Filed: Mar. 15, 2004**

Related U.S. Application Data

(63) Continuation of application No. 09/536,076, filed on Mar. 24, 2000, now Pat. No. 6,706,002.

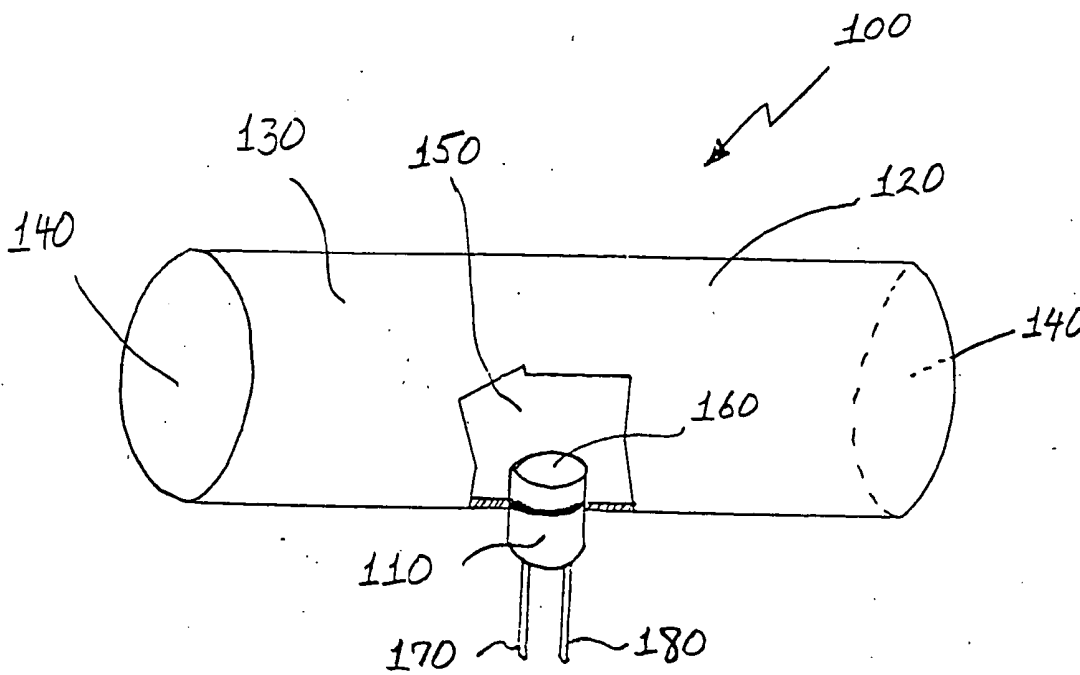

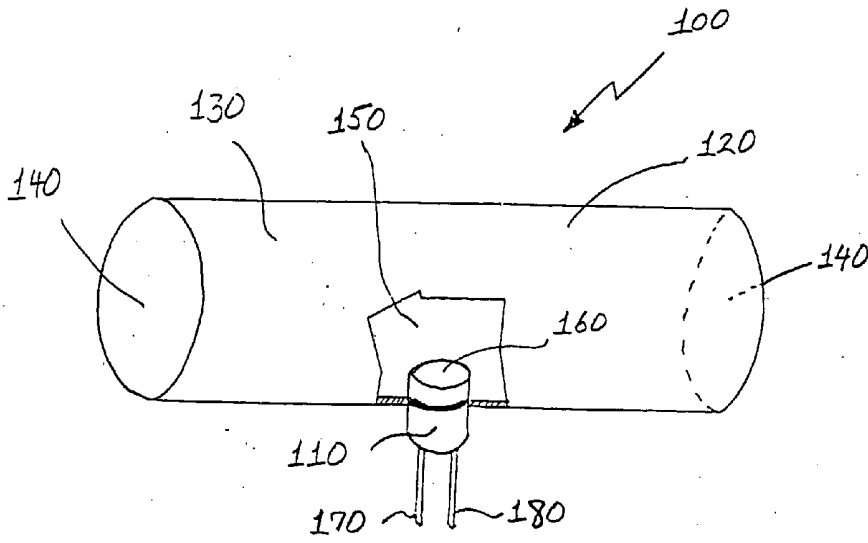

FIG. 1

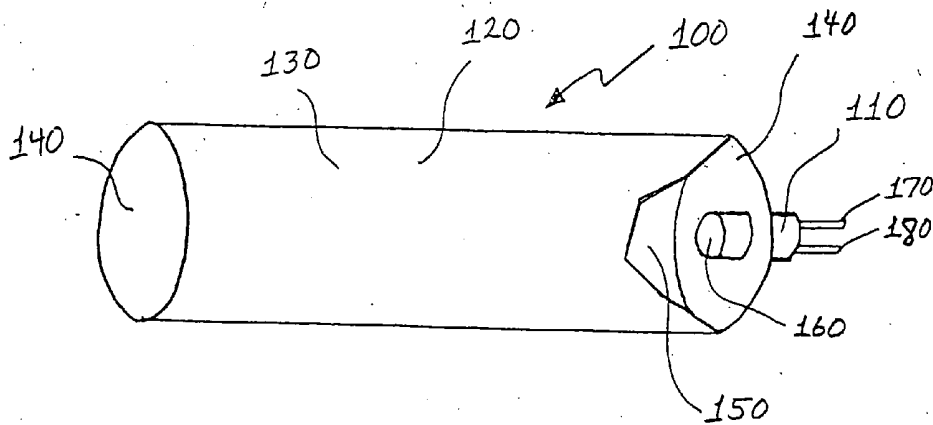

FIG. 2

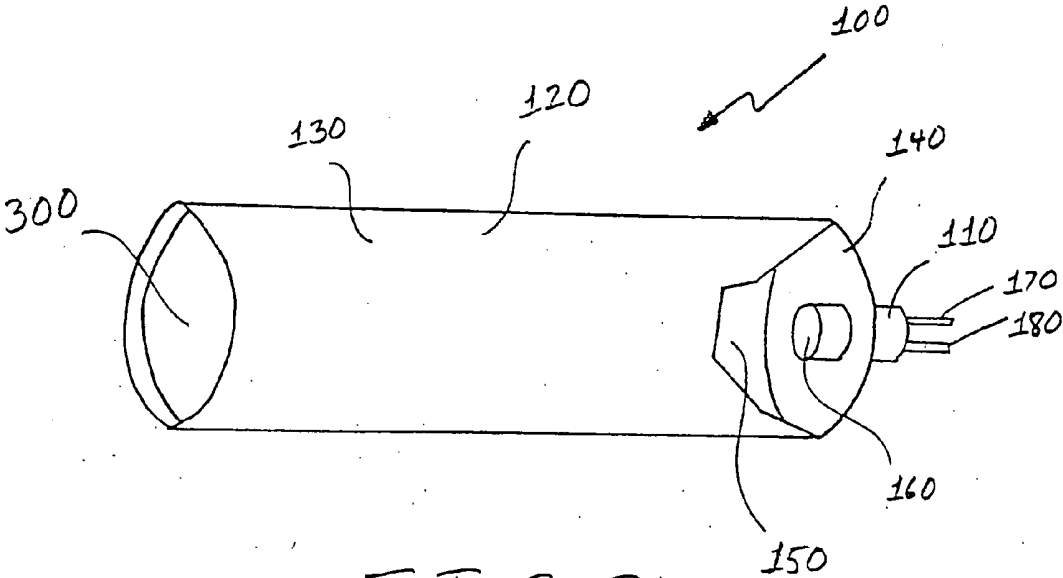

FIG. 3

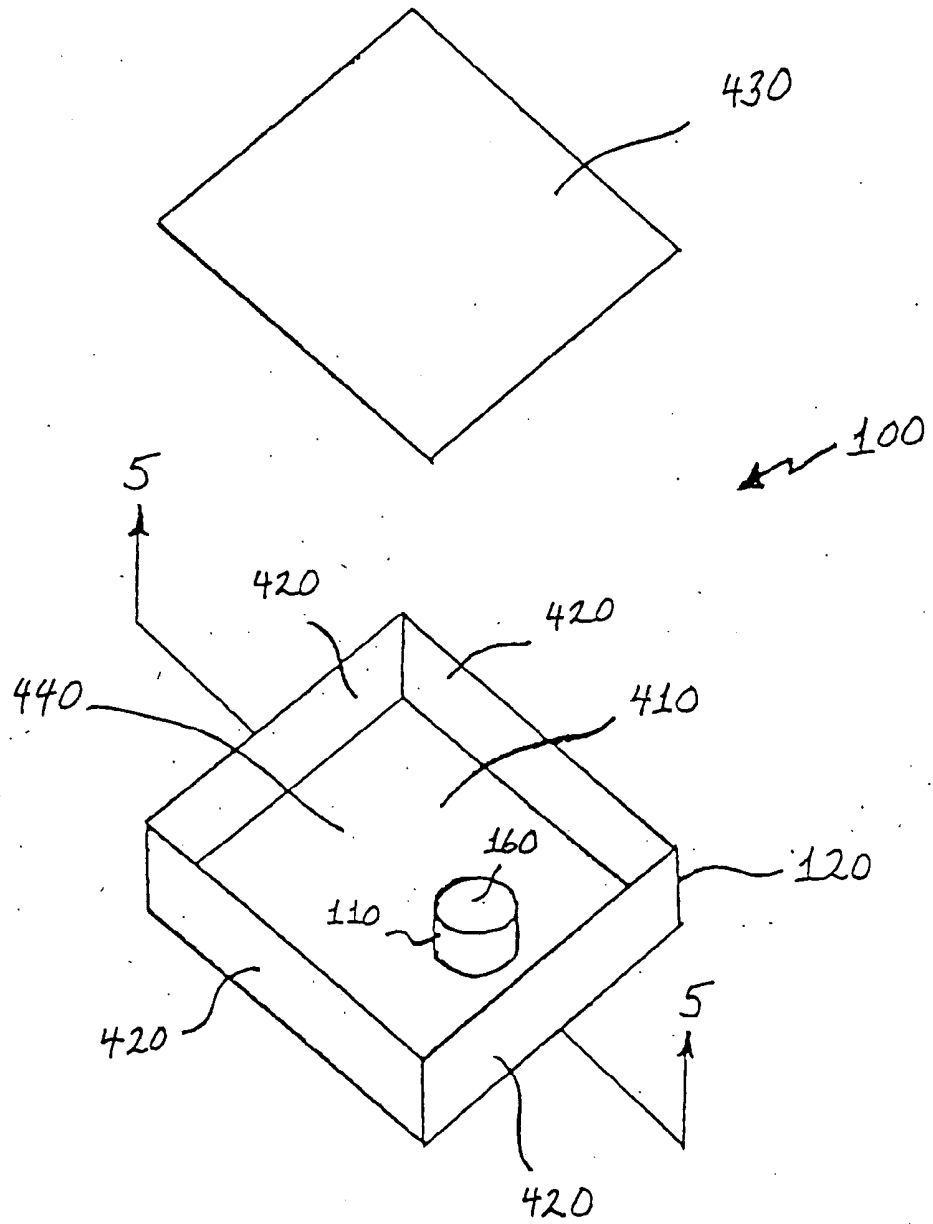

FIG. 4

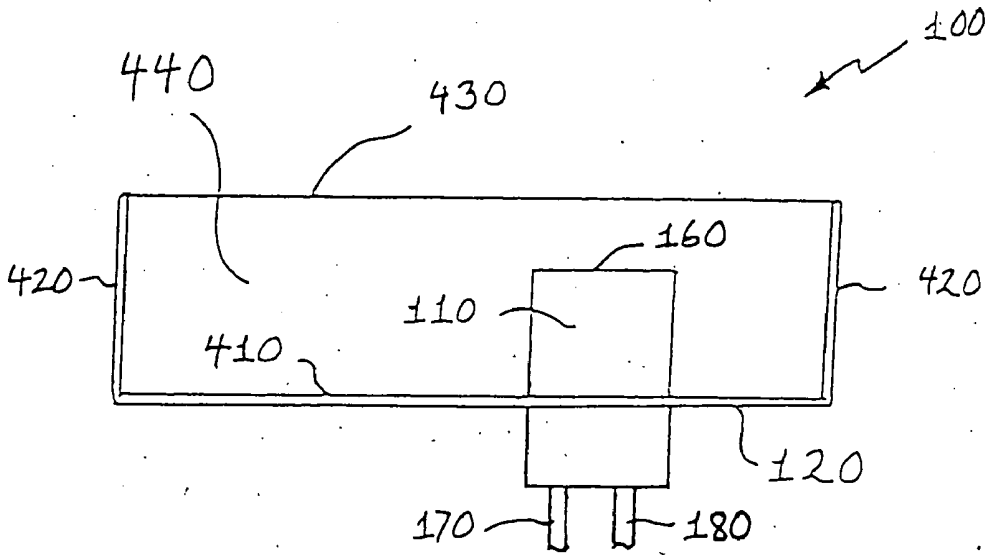

FIG. 5

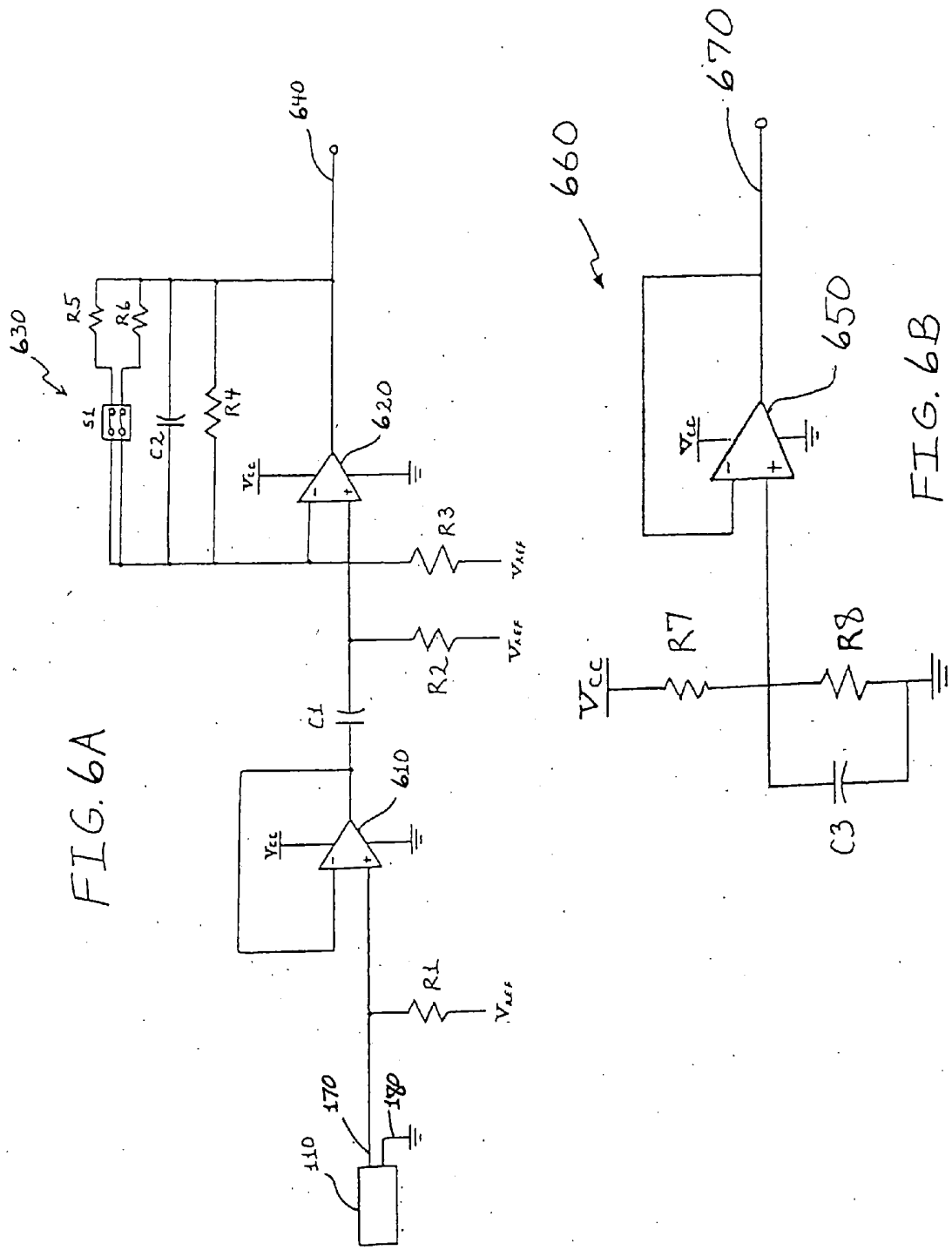

FIG. 6A

FIG. 6B

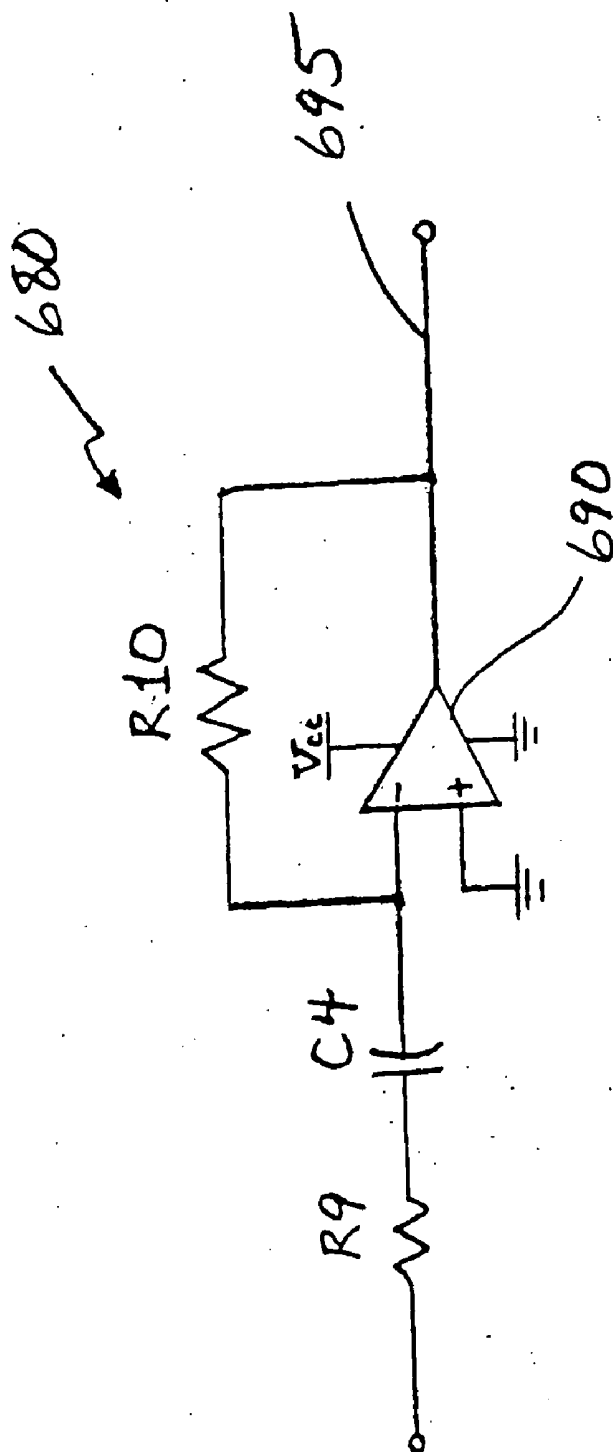

FIG. 6C

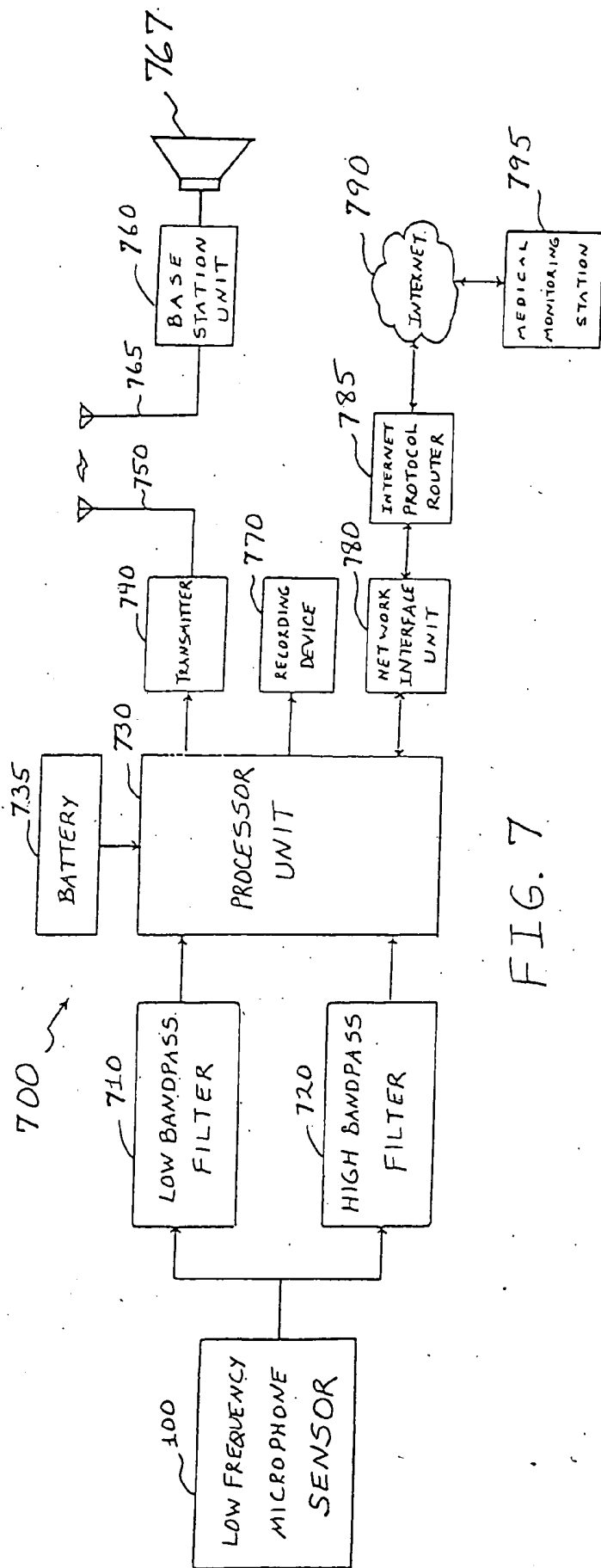

FIG. 7

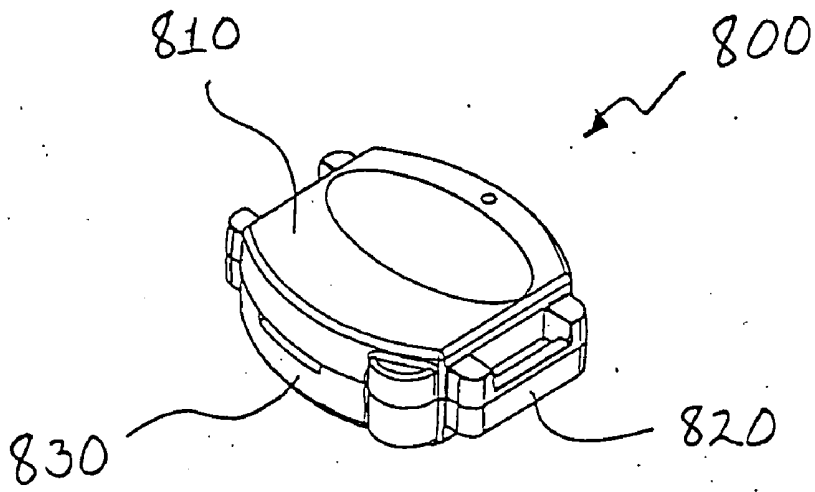

FIG. 8

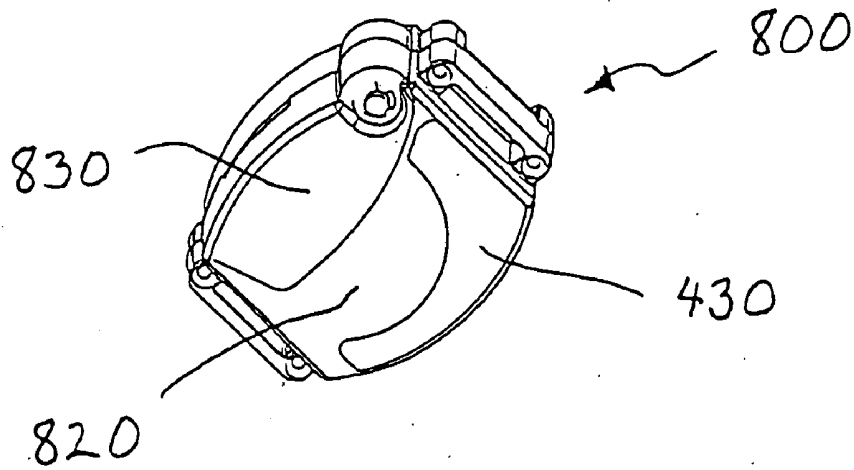

FIG. 9

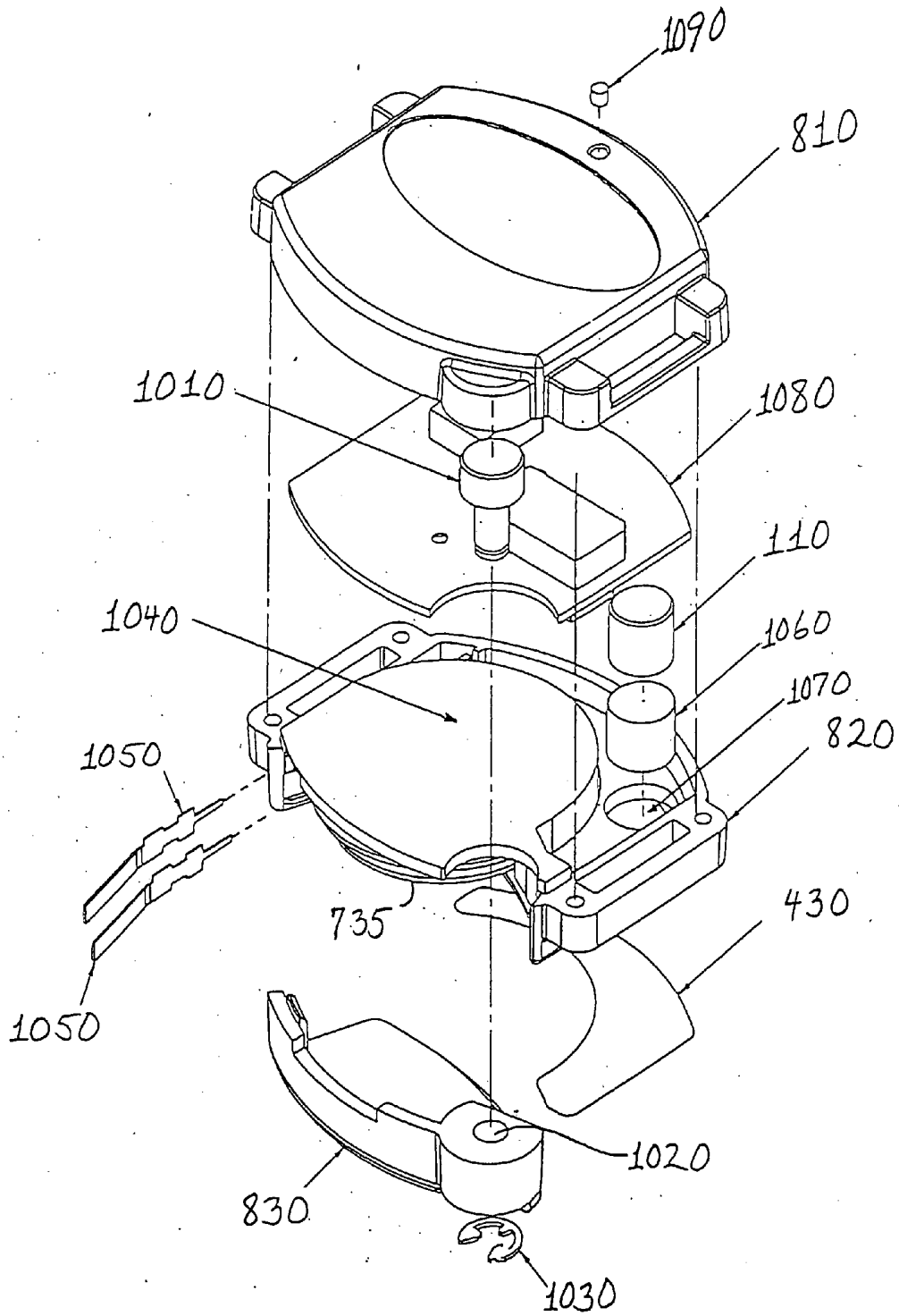

FIG. 10

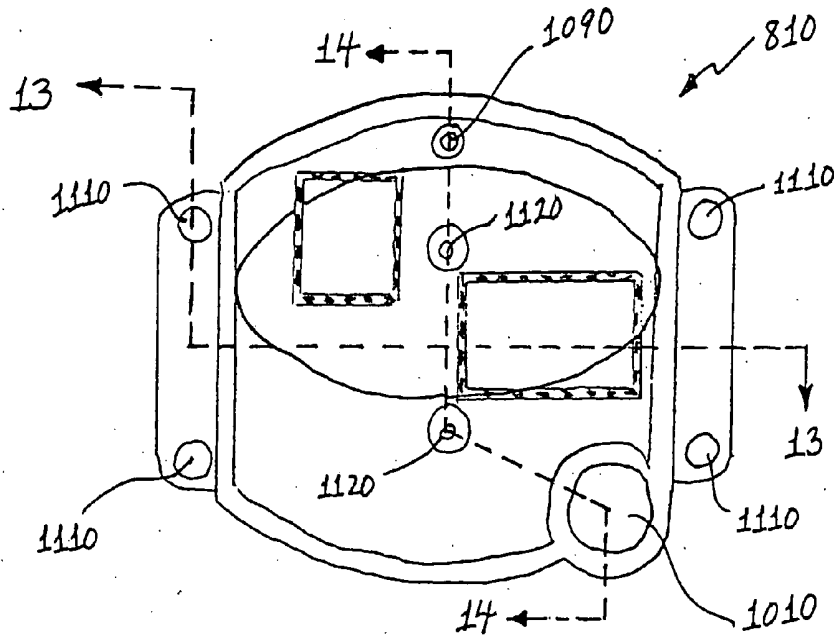

FIG. 11

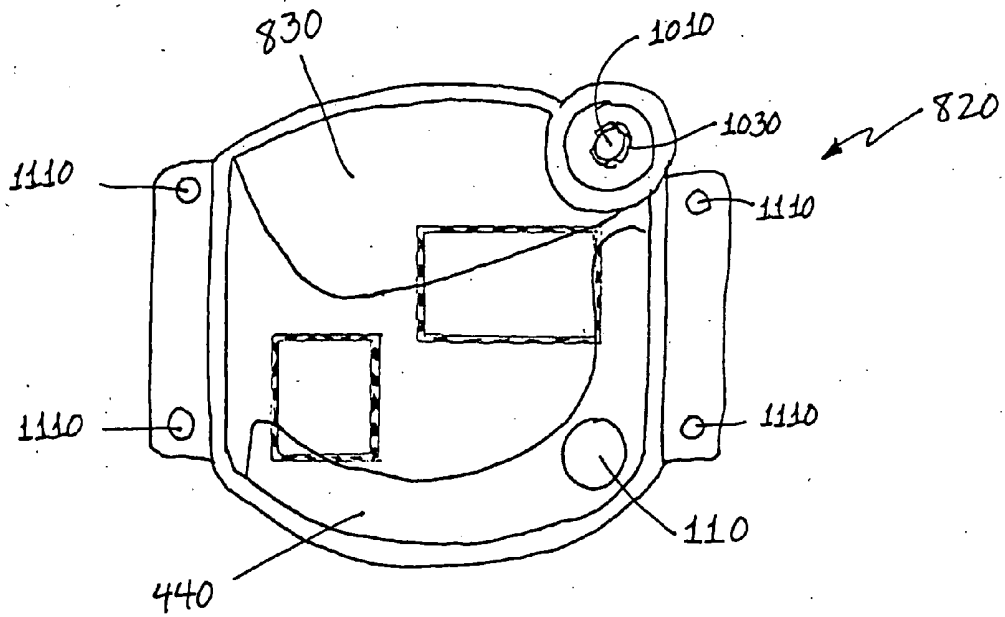

FIG. 12

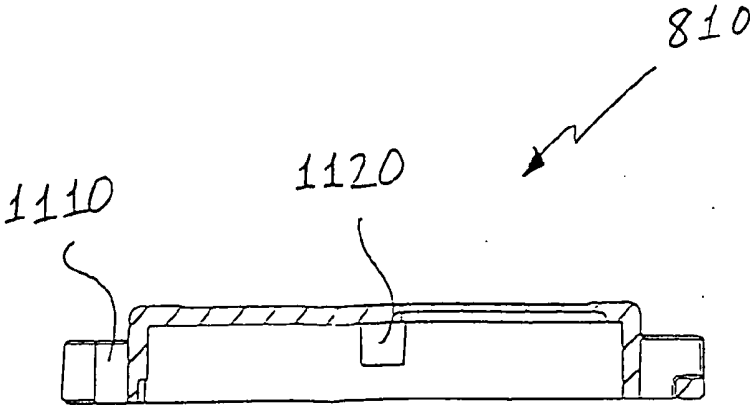

FIG. 13

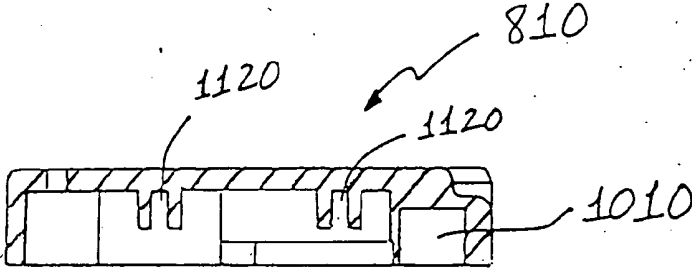
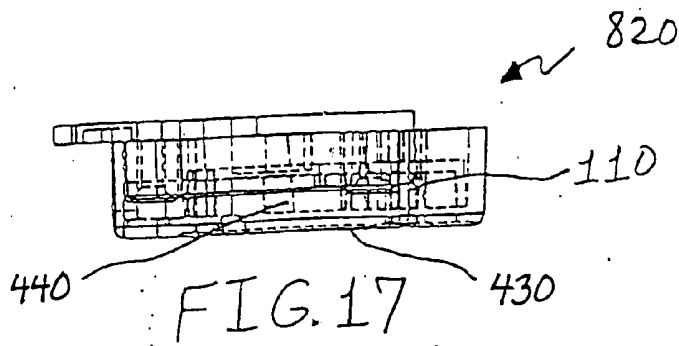
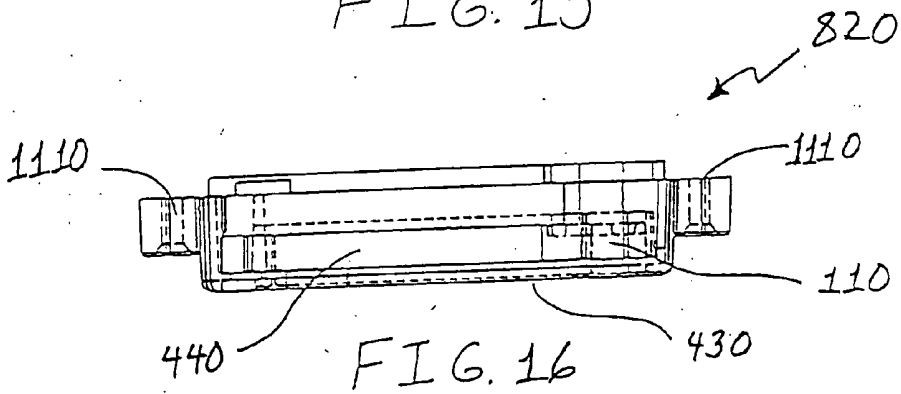
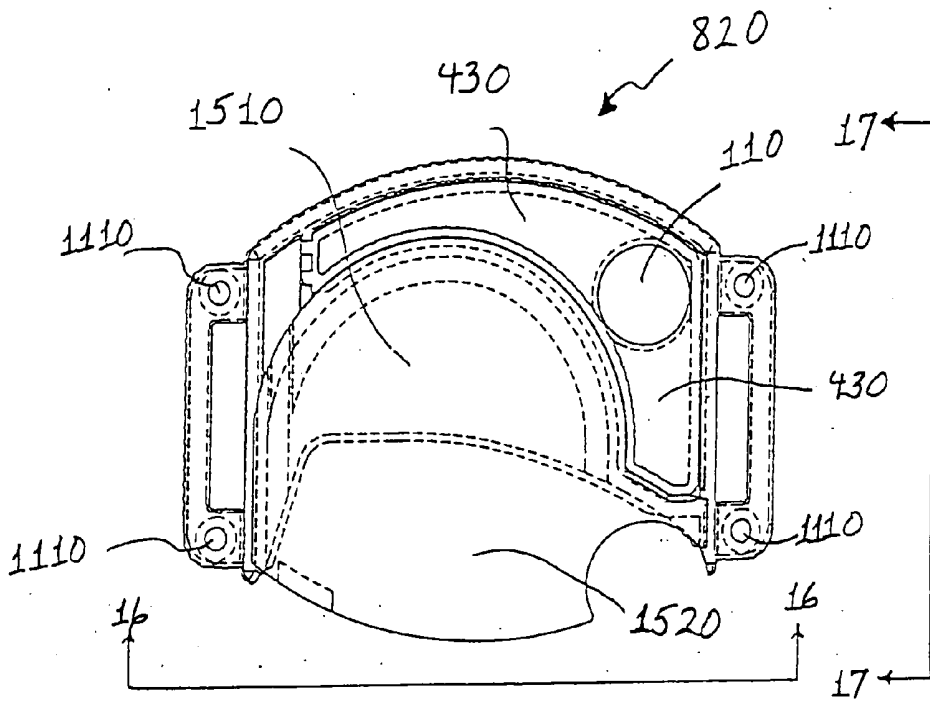

FIG. 14



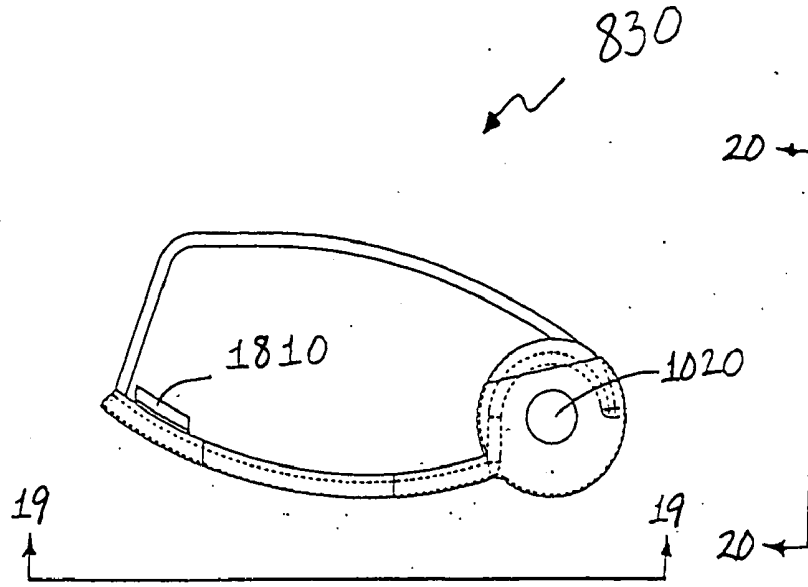

FIG. 18

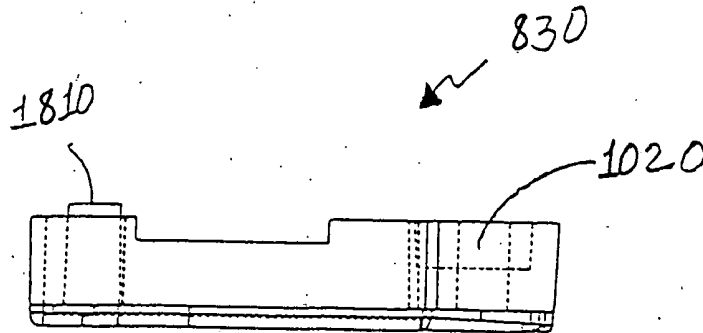

FIG. 19

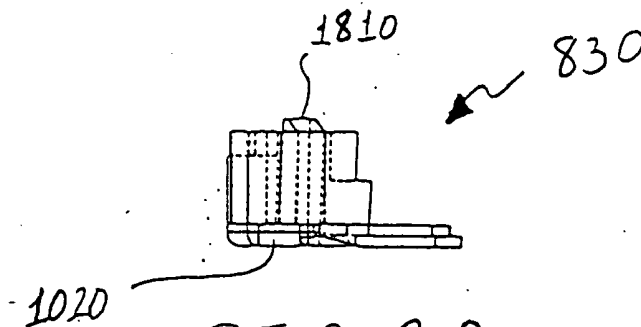

FIG. 20

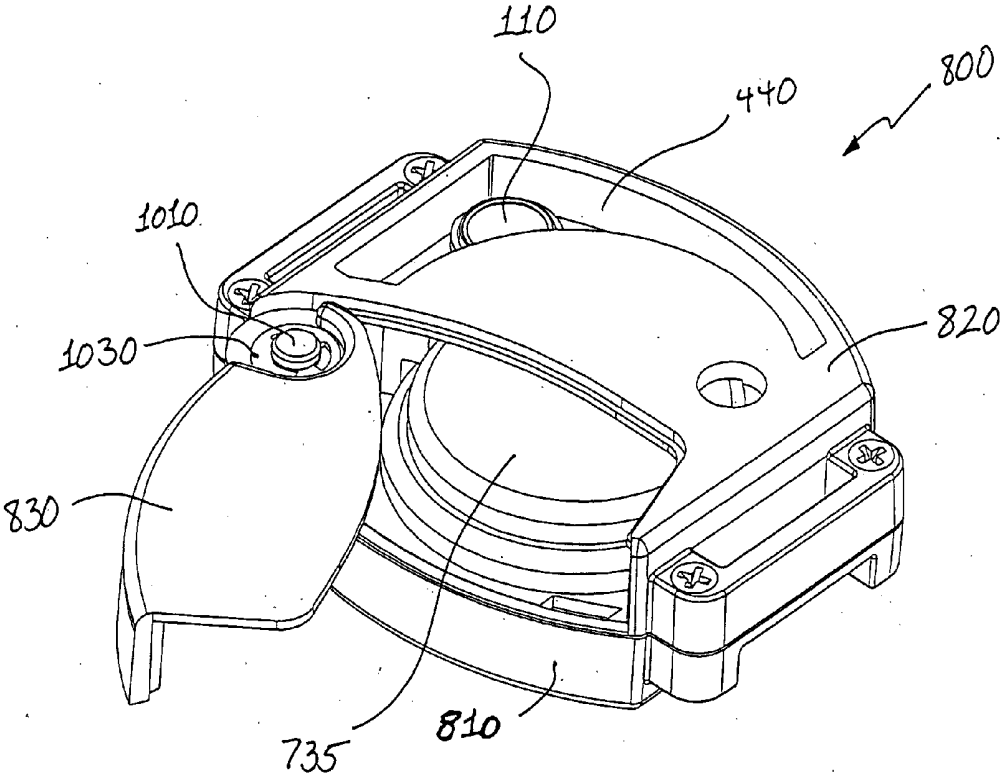

FIG. 21

SYSTEM AND METHOD FOR REMOTELY MONITORING AT LEAST ONE PHYSIOLOGICAL CHARACTERISTIC OF A CHILD

RELATED APPLICATIONS

[0001] A related patent application by M. E. Halleck and M. D. Halleck has been filed concurrently with this patent application entitled "Apparatus and Method for Detecting Very Low Frequency Acoustic Signals" (Attorney Docket No. ILIF01-00036). Another related patent application by M. E. Halleck and M. D. Halleck has been filed concurrently with this patent application entitled "Sensor and Method for Detecting Very Low Frequency Acoustic Signals" (Attorney Docket No. ILIF01-00052). Another related patent application by M. E. Halleck, M. D. Halleck, M. L. Lehrman and A. R. Owens has been filed concurrently with this patent application entitled "Physiological Condition Monitors Utilizing Very Low Frequency Acoustic Signals" (Attorney Docket No. ILIF01-00053) Another related patent application by M. E. Halleck, M. D. Halleck and G. V. Halleck has been filed concurrently with this patent application entitled "System and Method for Seizing A Communication Channel in A Commercially Available Child Monitor" (Attorney Docket No. 54).

TECHNICAL FIELD OF THE INVENTION

[0002] The present invention is directed to physiological condition monitors that utilize very low frequency acoustic signals to detect cardiac activity and respiration activity in children. The immediate detection of a child's irregular heartbeat or the cessation of the child's respiration can be used to prevent the death of the child. The present invention is directed to an apparatus and method for detecting very low frequency acoustic signals that represent physiological activity. The present invention comprises a sensor and a method for detecting very low frequency acoustic signals in the frequency range of one tenth Hertz (0.1 Hz) to thirty Hertz (30.0 Hz). The sensor of the present invention is capable of obtaining physiological condition signals from a child without being directly coupled to the skin of the child.

BACKGROUND OF THE INVENTION

[0003] In the United States an estimated two thousand to three thousand infants a year suddenly die from unexplained causes. Apparently healthy children can suddenly die without any obvious cause of death. This phenomenon is known as Sudden Infant Death Syndrome. In the United States Sudden Infant Death Syndrome is the leading cause of death of children between the age of one month and one year. It is second only to congenital abnormalities as the leading overall cause of death for all children less than one year of age.

[0004] If a child begins to experience difficulty in breathing or begins to experience irregular heartbeat, whoever is caring for the child (usually one of the child's parents) may have only a few seconds to respond to the child's distress. Therefore, it is very desirable to be able to provide a child's care giver with immediate notification that the child is experiencing cardiac or respiratory difficulty. This may be achieved by using a physiological condition monitor that is capable of continuously monitoring the physiological conditions of the child.

[0005] Microphones in physiological condition monitors are used to detect sounds that are indicative of physiological processes. Physiological condition monitors are capable of obtaining and recording signals indicative of a child's physiological processes. The most commonly monitored physiological processes are respiration and cardiac activity. Physiological condition monitors that monitor respiration and cardiac activity usually comprise one or more sensors coupled to the body of the child whose physiological conditions are to be measured. The sensors are capable of sensing changes in physical parameters that are caused by the child's respiration and cardiac activity. Physiological condition monitors measure and record waveform signals received from the sensors. Electrocardiogram (ECG) waveform signals may be used to measure a child's cardiac activity. Respiration waveform signals may be electronically derived using techniques such as impedance pneumography or inductive plethysmography. Respiration waveform signals are used to measure a child's breathing rate and other types of information concerning respiration.

[0006] The present invention comprises a chamber and a microphone that is capable of detecting very low frequency acoustic signals. The present invention is capable of monitoring physiological conditions in children utilizing very low frequency acoustic signals. For purposes of illustration, the present invention will be described with reference to physiological condition monitors that are capable of monitoring respiration and cardiac activity. It is understood, however, that the present invention is not limited to use in respiration monitors, and is not limited to use in cardiac activity monitors, and is not limited to use in physiological condition monitors in general. The present invention may be used to detect, measure and record any type of very low frequency acoustic signal.

[0007] Low heart rate is referred to as bradycardia. High heart rate is referred to as tachycardia. Cessation of respiration is referred to as apnea. When a child exhibits apnea, bradycardia or tachycardia, a life threatening condition very likely exists. Physiological condition monitors that are capable of continuously monitoring a child's respiration and cardiac activity are extremely useful for quickly detecting apnea, bradycardia or tachycardia. Such physiological condition monitors are also useful for quickly detecting other abnormal conditions such as a very slow breathing rate or a very high breathing rate.

[0008] Children who are susceptible to Sudden Infant Death Syndrome are known to exhibit apnea and bradycardia. Physiological condition monitors that are capable of continually monitoring respiration and cardiac activity are particularly useful in the early detection of apnea or bradycardia in children. Most physiological condition monitors are equipped with an alarm system to sound an alert when such conditions are detected.

[0009] A physiological condition monitor may be coupled directly to a child while the child is sleeping in a bed. In such an arrangement the waveform signals from the sensors coupled to the child's body may be sent through wires directly to a detector circuit (and other circuitry) located in a console by the child's bed. The wires attached to the child restrict the child's movements and frequently become tangled as the child moves. The tangling of the wires can also result in the sensors becoming detached from the child. The loss of sensor contact can set off an alarm signal.

[0010] In other cases it is more practical to provide one or more sensors located in a belt, harness or item of clothing that is to be worn by the child. In this type of physiological condition monitor the waveform signal information from the sensors is transmitted via a radio frequency transmitter to a radio frequency receiver in a base station unit that is located away from the site of the physiological condition sensors. The base station unit contains circuitry for analyzing and recording the waveform signal information. The base station unit contains circuitry for detecting abnormal conditions in the child's breathing (such as apnea) or abnormal conditions in the child's cardiac activity (such as bradycardia or tachycardia). Because of the freedom of movement that this type of monitor provides, it is the preferred type of monitor for monitoring the physiological conditions of children.

[0011] If the data that is acquired by the physiological condition monitor is not transmitted to the base station unit and recorded there, then the data may be recorded in a memory data storage device located within the physiological condition monitor. To preserve the freedom of movement that is provided by a monitor that is worn on a belt, harness or item of clothing, the memory data storage device within the physiological condition monitor must be battery powered.

[0012] Electrocardiogram (ECG) waveform signals may be used to obtain information concerning a child's cardiac activity. To obtain ECG waveforms an ECG sensor unit is coupled to the child. The ECG sensor unit is coupled to the child via electrodes capable of receiving cardiac activity signals directly from the child's body. In such an arrangement the electrodes must be attached directly to the child's skin in order to receive the signals. The ECG sensor unit receives the ECG electrical signals from the electrodes. The ECG signals received by the ECG sensor unit are then either recorded within the physiological condition monitor or transmitted to a base station unit.

[0013] It is possible to obtain information about cardiac activity from acoustic signals. For example, U.S. Pat. No. 4,306,567 to Krasner discloses a sensor apparatus coupled directly to the skin of a person. The Krasner sensor apparatus is capable of detecting acoustic signals from cardiac contractions within a frequency bandwidth between about thirty Hertz (30.0 Hz) and ninety Hertz (90.0 Hz). The acoustical energy associated with the cardiac contractions detected by the Krasner sensor apparatus exhibits a maximum signal-to-noise ratio at about forty five Hertz (45.0 Hz).

[0014] The Krasner sensor apparatus is also capable of detecting acoustic signals from breathing activity within a frequency bandwidth between about three hundred Hertz (300.0 Hz) and six hundred Hertz (600.0 Hz). The acoustical energy associated with the breathing activity detected by the Krasner sensor exhibits a maximum signal-to-noise ratio at about four hundred Hertz (400.0 Hz). The Krasner sensor simultaneously detects both the cardiac activity signals at about forty five Hertz (45.0 Hz) and the breathing activity signals at about four hundred Hertz (400.0 Hz) with a single sensor unit coupled directly to the skin.

[0015] Acoustic signals normally contain noise artifacts. We have determined that most of the noise artifacts present in acoustic signals due to respiration and cardiac activity may be eliminated by considering only the very low frequency components of acoustic signals. In particular, almost

all noise artifacts that are present in acoustic signals that are due to respiration and cardiac activity may be totally eliminated by filtering out all components of the signal that are outside the frequency range of one tenth Hertz (0.1 Hz) to thirty Hertz (30.0 Hz). This is due to the fact that most noise artifacts occur at frequencies that are higher than these frequencies.

[0016] We have also determined that sensor devices capable of detecting signals in the very low acoustic frequency range of one tenth Hertz (0.1 Hz) to thirty Hertz (30.0 Hz) do not need to be coupled directly to the skin of the child whose physiological conditions are being monitored. A sensor device that detects acoustic signals in the very low acoustic frequency range of one tenth Hertz (0.1 Hz) to thirty Hertz (30.0 Hz) in accordance with the principles of the present invention is capable of detecting the acoustic signals from the child's body through the child's clothes.

[0017] For these reasons it is advantageous to be able to detect very low frequency acoustic signals in the range of one tenth Hertz (0.1 Hz) to thirty Hertz (30.0 Hz). It is also advantageous to have an apparatus for monitoring physiological conditions in which it is not necessary to couple a sensor unit directly to the skin of the child being monitored. It is also advantageous to have an apparatus for monitoring physiological conditions which is capable of detecting acoustic signals through the child's clothes.

SUMMARY OF THE INVENTION

[0018] The present invention comprises an improved physiological condition monitor that is capable of detecting very low frequency acoustic signals in the range of one tenth Hertz (0.1 Hz) to thirty Hertz (30.0 Hz). The very low frequency acoustic signals are useful in monitoring physiological conditions in children such as respiration and cardiac activity. The present invention is capable of detecting signals in a frequency range that is lower than the range of frequencies previously used to detect acoustic signals for monitoring physiological conditions.

[0019] An advantageous embodiment of the present invention comprises a chamber and a microphone that is capable of detecting very low frequency acoustic signals in the range of one tenth Hertz (0.1 Hz) to thirty Hertz (30.0 Hz). An advantageous embodiment of the chamber of the present invention comprises a closed chamber containing a fluid. The fluid may be either a liquid or a gas. In most instances the fluid that is used is air. The walls of the chamber are not completely rigid. The walls of the chamber are capable of expanding and contracting (i.e., moving inwardly and outwardly with respect to the interior cavity of the chamber) in response to external inputs of mechanical energy that form waves of very low frequency acoustical energy within the chamber.

[0020] The mechanical energy from outside the chamber forms waves of very low frequency acoustical energy within the chamber and causes the walls of the chamber to expand and contract by extremely small amounts. The extremely small expansions and contractions of the walls of the chamber cause the molecules of fluid in the chamber (usually molecules of air) to move in low frequency acoustic waves throughout the cavity of the chamber.

[0021] The present invention further comprises a microphone within the chamber. The microphone is capable of detecting the low frequency acoustic waves of the molecules of fluid in the chamber that are caused by the mechanical energy that causes the walls of the chamber to expand and contract.

[0022] Prior art acoustic sensors directly detect higher frequency sounds that are made by the lungs during respiration or by the heart during cardiac activity. The sensor of the present invention, however, obtains information by detecting very low frequency signals caused by the motion of the chest during respiration and by detecting very low frequency signals associated with cardiac activity. Almost all of the noise components in an acoustic signal have frequencies that are above the very low frequency range. By using the method of the present invention to exclude the higher frequencies of sound (and noise), the sensor of the present invention eliminates almost all the noise artifacts from the acoustic signal.

[0023] The present invention is capable of detecting acoustic signals from cardiac activity within a frequency bandwidth between about ten Hertz (10.0 Hz) and thirty Hertz (30.0 Hz). The acoustical energy associated with the cardiac activity detected by the present invention exhibits a maximum signal-to-noise ratio at about sixteen Hertz (16.0 Hz).

[0024] The present invention is capable of detecting acoustic-signals from respiration within a frequency bandwidth between about one tenth Hertz (0.1 Hz) and two Hertz (2.0 Hz). The acoustical energy associated with the respiration detected by the present invention exhibits a maximum signal-to-noise ratio at about one and one half Hertz (1.5 Hz).

[0025] It is a primary object of the present invention to provide an improved apparatus and method for detecting very low frequency acoustic signals in the frequency range of one tenth Hertz (0.1 Hz) to thirty Hertz (30.0 Hz).

[0026] It is also an object of the present invention to provide an improved physiological condition monitor that is capable of detecting very low frequency acoustic signals in the frequency range of one tenth Hertz (0.1 Hz) to thirty Hertz (30.0 Hz) indicative of physiological conditions.

[0027] It is also an object of the present invention to provide an improved physiological condition monitor with a sensor unit capable of detecting very low frequency acoustic signals indicative of physiological conditions in a child where the sensor unit is not coupled directly to the skin of the child being monitored.

[0028] It is also an object of the present invention to provide an improved physiological condition monitor with a sensor unit capable of detecting very low frequency acoustic signals indicative of physiological conditions in a child where the sensor unit is capable of detecting such signals through the clothes of the child being monitored.

[0029] It is also an object of the present invention to provide an improved physiological condition monitor capable of detecting acoustic signals from cardiac activity of a child within a frequency bandwidth between about ten Hertz (10.0 Hz) and thirty Hertz (30.0 Hz).

[0030] It is a further object of the present invention to provide an improved physiological condition monitor capable of detecting acoustic signals from respiration of a child within a frequency bandwidth between about one tenth Hertz (0.1 Hz) and two Hertz (2.0 Hz).

[0031] The foregoing has outlined rather broadly the features and technical advantages of the present invention so that those skilled in the art may better understand the detailed description of the invention that follows. Additional features and advantages of the invention will be described hereinafter that form the subject of the claims of the invention. Those skilled in the art should appreciate that they may readily use the conception and the specific embodiment disclosed as a basis for modifying or designing other structures for carrying out the same purposes of the present invention. Those skilled in the art should also realize that such equivalent constructions do not depart from the spirit and scope of the invention in its broadest form.

[0032] Before undertaking the Detailed Description, it may be advantageous to set forth definitions of certain words and phrases used throughout this patent document: the terms "include" and "comprise" and derivatives thereof mean inclusion without limitation; the term "or," is inclusive, meaning and/or; the phrases "associated with" and "associated therewith," as well as derivatives thereof, may mean to include, be included within, interconnect with, contain, be contained within, connect to or with, couple to or with, be communicable with, cooperate with, interleave, juxtapose, be proximate to, be bound to or with, have, have a property of, or the like; and the term "controller" means any device, system or part thereof that controls at least one operation, such a device may be implemented in hardware, firmware, or software, or some combination of at least two of the same. It should be noted that the functionality associated with any particular controller may be centralized or distributed, whether locally or remotely. Definitions for certain words and phrases are provided throughout this patent document. Those of ordinary skill in the art should understand that in many, if not most, instances, such definitions apply to prior, as well as future uses of such defined words and phrases.

BRIEF DESCRIPTION OF THE DRAWINGS

[0033] For a more complete understanding of the present invention, and the advantages thereof, reference is now made to the following descriptions taken in conjunction with the accompanying drawings, wherein like numbers designate like objects, and in which:

[0034] **FIG. 1** is a partially cutaway view showing one embodiment of the sensor of the present invention and showing the sensor chamber as a tube and showing the placement of the microphone of the present invention in one of the side walls of the sensor chamber; and

[0035] **FIG. 2** is a partially cutaway view showing another embodiment of the sensor of the present invention and showing the sensor chamber as a tube and showing the placement of the microphone of the present invention in one of the end walls of the sensor chamber; and

[0036] **FIG. 3** is a partially cutaway view showing another embodiment of the sensor of the present invention and showing the sensor chamber as a tube with one open end and showing the placement of the microphone of the present invention in the closed end of the sensor chamber; and

[0037] FIG. 4 is an exploded view showing another embodiment of the sensor of the present invention and showing the sensor chamber as a rectangular box and showing the placement of the microphone of the present invention within the rectangular box; and

[0038] FIG. 5 is a cross sectional view of the embodiment of the sensor of the present invention shown in FIG. 4 taken along line 5-5 of FIG. 4; and

[0039] FIGS. 6A, 6B and 6C are circuit diagrams of an advantageous embodiment of circuitry for processing electrical signals from the microphone of the present invention; and

[0040] FIG. 7 is a block diagram of an advantageous embodiment of a physiological condition monitor of the present invention; and

[0041] FIG. 8 is a perspective top view of an advantageous embodiment of the monitor housing of the physiological condition monitor of the present invention; and

[0042] FIG. 9 is a perspective bottom view of the advantageous embodiment of the monitor housing of the physiological condition monitor of the present invention shown in FIG. 8; and

[0043] FIG. 10 is an exploded perspective top view of the monitor housing of the physiological condition monitor showing the interconnection of the components of the monitor housing; and

[0044] FIG. 11 is a plan view of the top housing of the monitor housing; and

[0045] FIG. 12 is a plan view of the bottom of the assembled physiological condition monitor; and

[0046] FIG. 13 is a cross sectional view of the top housing of the monitor housing taken along line 13-13 of FIG. 11; and

[0047] FIG. 14 is a cross sectional view of the top housing of the monitor housing taken along line 14-14 of FIG. 11; and

[0048] FIG. 15 is a plan view of the bottom housing of the monitor housing; and

[0049] FIG. 16 is a side elevation view of the bottom housing of the monitor housing taken along line 16-16 of FIG. 15; and

[0050] FIG. 17 is an end elevation view of the bottom housing of the monitor housing taken along line 17-17 of FIG. 15; and

[0051] FIG. 18 is a plan view of the battery door of the monitor housing; and

[0052] FIG. 19 is a side elevation view of the battery door of the monitor housing taken along line 19-19 of FIG. 18; and

[0053] FIG. 20 is an end elevation view of the battery door of the monitor housing taken along line 20-20 of FIG. 18; and

[0054] FIG. 21 is a perspective bottom view of the monitor housing showing the battery door in an open position and showing the placement of a battery in the monitor housing.

DETAILED DESCRIPTION

[0055] FIGS. 1 through 21, discussed below, and the various embodiments used to describe the principles of the present invention in this patent document are by way of illustration only and should not be construed in any way to limit the scope of the invention. Those skilled in the art will understand that the principles of the present invention may be implemented in a suitably modified sensor or in a suitably modified physiological condition monitor.

[0056] FIG. 1 is a partially cutaway view showing an advantageous embodiment of sensor 100 of the present invention. Sensor 100 comprises a chamber 120 and a microphone 110. In this embodiment chamber 120 comprises a hollow tube having side walls 130 and end walls 140 that form cavity 150 within chamber 120. Cavity 150 of chamber 120 is filled with a fluid (not shown). The connections between side walls 130 and end walls 140 are sealed to prevent the escape of the fluid from cavity 150. The fluid may be either a liquid or a gas. In most instances the fluid that is used is air.

[0057] When the fluid that is used is air, the connections between side walls 130 and end walls 140 are not hermetically sealed. A small amount of air may pass through the connections between side walls 130 and end walls 140 to adjust for variations in ambient air pressure in the atmosphere.

[0058] Microphone 110 is mounted within chamber 120 so that the face 160 of microphone 110 is within the fluid in cavity 150 of chamber 120. Microphone 110 may be mounted at any position within chamber 120. In one advantageous embodiment of the present invention shown in FIG. 1 microphone 110 is mounted within one of the side walls 130 of chamber 120. In an alternate advantageous embodiment of the present invention shown in FIG. 2 microphone 110 is mounted within one of the end walls 140 of chamber 120. Microphone 110 also has microphone output cables, 170 and 180, for coupling microphone 110 to other electronic equipment (not shown in FIG. 1 or FIG. 2).

[0059] The side walls 130 (and end walls 140) of chamber 120 are constructed of material that is not completely rigid. The material used to construct the walls, 130 and 140, may be thin metal or plastic. Because the walls, 130 and 140, are not completely rigid, they are capable of expanding and contracting (i.e., moving inwardly and outwardly) with respect to the interior of cavity 150 of chamber 120. The ability of the walls, 130 and 140, of sensor 100 to expand and contract in response to the presence of waves of low frequency acoustical energy in chamber 120 is a key feature of the present invention.

[0060] When acoustical energy from a source (not shown) reaches chamber 120 of sensor 100 the acoustical energy contains both high frequency acoustic signal components and low frequency acoustic signal components. The walls 130 and the end walls 140 of chamber 120 of sensor 100 expand and contract in response to the presence of the very low frequency acoustic signal components. The presence of waves of very low frequency acoustic energy in chamber 120 of sensor 100 cause the walls, 130 and 140, of chamber 120 to expand and contract by extremely small amounts.

[0061] The extremely small expansions and contractions of the walls, 130 and 140, of chamber 120 of sensor 100 in

response to the presence of very low frequency acoustic signals cause the molecules of fluid in chamber 120 (usually molecules of air) to move in low frequency waves throughout the cavity 150 of chamber 120. Microphone 110 is capable of detecting the low frequency waves of molecules of fluid in chamber 120 that are caused by the low frequency acoustic signal components in the acoustical energy that cause the walls, 130 and 140, of chamber 120 to expand and contract.

[0062] When microphone 110 receives low frequency acoustic signals then microphone 110 generates electronic signals indicative of the intensity of the low frequency acoustic signals. Electronic processing circuits (shown in FIGS. 6A, 6B and 6C) in a physiological condition monitor 700 (shown in FIG. 7) are coupled to microphone 110 through microphone output cables, 170 and 180, to receive and analyze the electronic signals that are indicative of the intensity of the low frequency acoustic signals.

[0063] The electronic processing circuits comprise electronic filters for filtering out all components of the signal that are outside the frequency range of one tenth Hertz (0.1 Hz) to thirty Hertz (30.0 Hz). The electronic processing circuits also comprise electronic filters for filtering out all components of the signal that are outside the frequency range of one tenth Hertz (0.1 Hz) to two Hertz (2.0 Hz) to obtain a signal indicative of respiration. The electronic processing circuits also comprise electronic filters for filtering out all components of the signal that are outside the frequency range of ten Hertz (10.0 Hz) to thirty Hertz (30.0 Hz) to obtain a signal indicative of cardiac activity.

[0064] Prior art sensors directly detect higher frequency sounds that are made by the lungs during respiration or by the heart during cardiac activity. Sensor 100 of the present invention, however, obtains information by detecting very low frequency signals caused by the motion of the chest during respiration and by detecting very low frequency signals associated with cardiac activity. Almost all of the noise components in an acoustic signal have frequencies that are above the very low frequency range. Using the method of the present invention to exclude the higher frequencies of sound (and noise), sensor 100 of the present invention eliminates almost all the noise artifacts from the acoustic signal.

[0065] An alternate advantageous embodiment of the present invention is shown in FIG. 3. The embodiment shown in FIG. 3 is similar to that shown in FIG. 2 except that chamber 120 of sensor 100 comprises an open ended tube having portions that form an aperture 300. In this embodiment cavity 150 of chamber 120 has access to the surrounding atmosphere through aperture 300 in the open end of the tube. In the embodiment shown in FIG. 3 microphone 110 is placed within the end wall 140 of the closed end of the tube. Alternatively, microphone 110 could be placed within a side wall 130 of an open ended tube. This embodiment shows that it is possible to practice the invention where the fluid in chamber 120 is air that has access to the air of the surrounding environment.

[0066] Although chamber 120 of sensor 100 has been shown in the shape and form of a tube, it is clear that the invention may be practiced with a chamber 120 of sensor 100 that has a different type of shape and form. One such alternate embodiment of the present invention is shown in FIG. 4.

[0067] FIG. 4 shows an exploded view of an alternate advantageous embodiment of sensor 100 of the present invention. Sensor 100 comprises microphone 110 mounted within chamber 120. Microphone 110 may be mounted at any position on the interior surface of the bottom 410 of chamber 120. In the embodiment of the invention shown in FIG. 4 the shape of chamber 120 is rectangular. However, the shape of chamber 120 may be circular, elliptical, or of irregular shape. The height of the walls 420 of chamber 120 are greater than the height of microphone 110 so that the face 160 of microphone 110 is contained within chamber 120.

[0068] Membrane 430 covers the top of chamber 120. Membrane 430 has a shape that matches the shape of the top of chamber 120. In the embodiment of sensor 100 shown in FIG. 4, that shape is rectangular. When membrane 430 is attached to the top edges of the walls 420 of chamber 120, then a cavity 440 is formed between membrane 430 and walls 420 and bottom 410 of chamber 120. In one advantageous embodiment of the present invention, the height of the walls 420 are only slightly greater than the height of microphone 110 so that the face 160 of microphone 110 is positioned near membrane 430.

[0069] In one advantageous embodiment of the present invention membrane 430 is made of urethane. However, membrane 430 may also be made of other suitable materials. Before membrane 430 is attached to the top of chamber 120 membrane 430 is slightly stretched. The slight stretching of membrane 430 is to make membrane 430 taut across the top of chamber 120.

[0070] When sensor 100 is used to detect acoustic signals indicative of physiological conditions, chamber 120 is placed next to the body (not shown) of the person whose physiological conditions are being monitored. Chamber 120 is placed with the outer surface of membrane 430 adjacent to a selected area of the body. It is not necessary that membrane 430 touch the skin of the body. There may be a layer of clothing between the skin of the body and membrane 430. Membrane 430 is thereby acoustically coupled to the area of the body where membrane 430 is placed.

[0071] Membrane 430 acquires very low frequency acoustic signals in the form of vibrations from the area of the body to which it is acoustically coupled. That is, as the very low frequency acoustic vibrations from the body impinge upon membrane 430 they cause membrane 430 to vibrate. These vibrations of membrane 430 cause the very low frequency acoustic vibrations to pass into cavity 440 of chamber 120. The very low frequency acoustic vibrations resonate within the enclosed space of cavity 440.

[0072] FIG. 5 shows a cross sectional view of sensor 100 showing cavity 440 and one possible location for the placement of microphone 110 within cavity 440. Microphone 110 detects the very low frequency acoustic vibrations that are resonating within cavity 440.

[0073] The interaction of membrane 430 and resonant cavity 440 increases the amplitude of the very low frequency acoustic signals from the body so that microphone 110 may more easily detect the signals. The interaction of membrane 430 and resonant cavity 440 accomplishes this increase in acoustic signal strength by forming an acoustic echo chamber in which membrane 430 acts as a drumhead and resonant cavity 440 acts as a drum. The resonance of the very low

frequency acoustic signals within resonant cavity 440 causes the amplitudes of the acoustic waves within resonant cavity 440 to combine in phase and thereby increase the acoustic signal strength of the acoustic signals that were originally incident on membrane 430.

[0074] The increase in amplitude of the signals provided by the interaction of membrane 430 and resonant cavity 440 enables microphone 110 to efficiently detect signals in the very low frequency range of one tenth Hertz (0.1 Hz) to thirty Hertz (30.0 Hz). This very low frequency range includes the very low frequency range used to detect respiration signals (i.e., one tenth Hertz (0.1 Hz) to two Hertz (2.0 Hz)) and the very low frequency range used to detect cardiac information signals (i.e., ten Hertz (10.0 Hz) to thirty Hertz (30.0 Hz)). The interaction of membrane 430 and resonant cavity 440 assists microphone 110 in detecting very low acoustic signals in the required signal ranges.

[0075] To improve reception of the very low frequency acoustic signals, the surface area of membrane 430 is larger than the surface area of the face 160 of microphone 110. In an advantageous embodiment of the present invention the surface area of membrane 430 is at least five (5) times greater than the surface area of the face 160 of microphone 110. The presence of membrane 430 significantly increases the area which may be acoustically coupled to microphone 110. The relatively large area of membrane 430 permits larger areas of a body to be analyzed than would otherwise be possible.

[0076] When microphone 110 receives low frequency acoustic signals then microphone 110 generates electronic signals indicative of the intensity of the low frequency acoustic signals. As described more fully below, electronic processing circuits in physiological condition monitor 700 are coupled to microphone 110 through microphone output cables, 170 and 180, to receive and analyze the electronic signals that are indicative of the intensity of the low frequency acoustic signals.

[0077] FIGS. 6A, 6B and 6C illustrate circuit diagrams of an advantageous embodiment of circuitry for processing electrical signals from the microphone of the present invention. As shown in FIG. 6A, microphone output cable 180 is grounded and microphone output cable 170 is coupled to the positive input of operational amplifier 610. The output of operational amplifier 610 is fed back to the negative input of operational amplifier 610 in order to configure operational amplifier 610 as a voltage follower (also known as a buffer amplifier circuit). The voltage follower configuration of operational amplifier 610 acts as a current amplifier for the signal current from microphone 110. The signal current that is output from operational amplifier 610 is an amplified version of the signal current from microphone 110. Operational amplifier 610 may be of the type manufactured by Texas Instruments Corporation with product model number TLV2211.

[0078] One end of a resistor R1 having a very large value is coupled to the signal line between microphone 110 and operational amplifier 610. The other end of resistor R1 is coupled to a reference voltage V_{REF} . A typical value of R1 is one teraohm (1.0 T). One teraohm is equal to one million million ohms. A very large resistance is needed to facilitate the signal processing of the very low frequency signals

detected by microphone 110. A typical value for reference voltage V_{REF} is one half of the voltage of the power supply battery.

[0079] The output signal from operational amplifier 610 is coupled via capacitor C1 to the positive input of operational amplifier 620. Operational amplifier 620 forms part of low bandpass filter circuit 630. Operational amplifier 620 may be of the type manufactured by Texas Instruments Corporation with product model number TLV2211.

[0080] A typical value of capacitor C1 is forty seven hundredths of a microfarad (0.47 μ F). One end of resistor R2 is coupled to the signal line between capacitor C1 and operational amplifier 620. The other end of resistor R2 is coupled to the reference voltage V_{REF} . A typical value of R2 is five and one tenth megohms (5.1 M).

[0081] Low bandpass filter circuit 630 comprises a double pole switch S1 for adjusting the value of the resistance that is coupled in parallel with capacitor C2. When both poles of switch S1 are in the open position, both resistor R5 and resistor R6 are excluded from the circuit. Resistor R5 or resistor R6 (or both) can be selectively included in the circuit by closing the appropriate pole (or both poles) of switch S1.

[0082] A typical value for capacitor C2 is thirty three thousandths of a microfarad (0.033 μ F). A typical value for resistor R3 is five hundred ten kilohms (510.0 K) and a typical value for resistor R4 is two megohms (2.0 M). A typical value for resistor R5 is one megohm (1.0 K) and a typical value for resistor R6 is two megohms (2.0 M).

[0083] The output of operational amplifier 620 of low bandpass filter circuit 630 appears at the output terminal 640.

[0084] FIG. 6B illustrates reference voltage generator circuit 660. The output of reference voltage generator circuit 660 is the reference voltage V_{REF} . The battery voltage V_{CC} is coupled via resistor R7 to the positive input of operational amplifier 650. Operational amplifier 650 forms part of the reference voltage generator circuit 660. Operational amplifier 650 may be of the type manufactured by Texas Instruments Corporation with product model number TLV2211. A typical value of resistor R7 is five and one tenth megohms (5.1 M).

[0085] One end of resistor R8 is coupled to the signal line between resistor R7 and operational amplifier 650. The other end of resistor R8 is grounded. Capacitor C3 is coupled in parallel with resistor R8. A typical value of resistor R8 is five and one tenth megohms (5.1 M). A typical value for capacitor C3 is one hundredth of a microfarad (0.01 μ F).

[0086] The output of operational amplifier 650 of reference voltage generator circuit 660 appears at the output terminal 670 as V_{REF} . The reference voltage V_{REF} is coupled to the ends of resistor R1, resistor R2 and resistor R3 as indicated in FIG. 6A.

[0087] FIG. 6C shows high bandpass filter circuit 680. High bandpass filter circuit 680 comprises operational amplifier 690. Operational amplifier 690 may be of the type manufactured by Texas Instruments Corporation with product model number TLV2211.

[0088] One end of resistor R9 is coupled to the signal line between capacitor C1 and operational amplifier 620. The

other end of resistor R9 is coupled to capacitor C4. A typical value of resistor R9 is thirty three kilohms (33 K). A typical value of capacitor C4 is forty seven hundredths of a microfarad (0.47 μ F). The output of capacitor C4 is coupled to the negative input of operational amplifier 690. The output of operational amplifier 690 is fed back via resistor R10 to the negative input of operational amplifier 690. The positive input of operational amplifier 690 is grounded. A typical value of resistor R10 is thirty three kilohms (33 K).

[0089] The output of operational amplifier 690 of high bandpass filter circuit 680 appears at the output terminal 695. The function of high bandpass filter circuit 680 may also be accomplished by utilizing digital signal processing methods. For example, the Fast Fourier Transform method may be utilized to perform the function of high bandpass filter 680.

[0090] FIG. 7 is a block diagram of an advantageous embodiment of a physiological condition monitor 700 that utilizes the low frequency microphone sensor 100 of the present invention. As previously described, low frequency microphone sensor 100 receives low frequency signals from the body (not shown) of a child whose physiological conditions are being monitored. Low frequency microphone sensor 100 detects and amplifies those signals as previously described.

[0091] As shown in FIG. 7, the output of low frequency microphone sensor 100 is coupled to an input of low bandpass filter 710. Low bandpass filter 710 screens out all frequencies except those frequencies in the frequency bandwidth range from one tenth Hertz (0.1 Hz) to two Hertz (2.0 Hz). Low bandpass filter 710 may comprise conventional electronic filter circuits. Low bandpass filter 710 may also comprise electronic circuitry that utilizes computer software to achieve the bandpass filter function by digital signal processing. The output of low bandpass filter 710 is a digitally encoded very low frequency signal representative of the respiration of the child being monitored.

[0092] The output of low frequency microphone sensor 100 is also coupled to an input of high bandpass filter 720. High bandpass filter 720 screens out all frequencies except those frequencies in the frequency bandwidth range from ten Hertz (10.0 Hz) to thirty Hertz (30.0 Hz). High bandpass filter 720 may comprise conventional electronic filter circuits. High bandpass filter 720 may also comprise electronic circuitry that utilizes computer software to achieve the bandpass filter function by digital signal processing. The output of high bandpass filter 720 is a digitally encoded very low frequency signal representative of the cardiac activity of the child being monitored.

[0093] The output of low bandpass filter 710 and the output of high bandpass filter 720, are coupled to processor unit 730. Processor unit 730 is capable of receiving digitally encoded signals from low bandpass filter 710 and from high bandpass filter 720. Battery 735 is coupled to processor unit 730 and is capable of supplying electrical power for the operation of processor unit 730. Although battery 735 is shown coupled only to processor unit 730 in FIG. 7, battery 735 is connected to and provides power to all components of physiological condition monitor 700 through other electrical connections (not shown). Processor unit 730 is capable of detecting a signal from battery 735 that indicates that the voltage level of battery 435 is low.

[0094] In one embodiment of the present invention, processor-unit 730 is coupled to radio frequency transmitter 740, which is itself coupled to antenna 750. Processor unit 730 is capable of selectively causing radio frequency transmitter 740 to transmit digitally encoded signals from low band pass filter 710 and digitally encoded signals from high band pass filter 720 to base station unit 760 via transmitter 740 and antenna 750. The digitally encoded signals are received by base station unit 760 via antenna 765. The received signals may then be displayed and analyzed at base station unit 760.

[0095] Processor unit 730 is capable of causing radio frequency transmitter 440 to transmit a signal to base station unit 760 that indicates that the voltage level of battery 735 is low. Processor unit 730 is also capable of causing radio frequency transmitter 740 to transmit a signal to base station unit 760 that indicates that processor unit 730 is not receiving signals from low bandpass filter 710 or from high bandpass filter 720. That is, processor unit 730 can transmit to base station unit 760 a signal indicating that one (or both) of the physiological conditions (breathing and heartbeat) is not being monitored.

[0096] Base station unit 760 is capable of sounding an alarm if an analysis of the received signals indicates an abnormal condition in the child being monitored. Base station unit 760 comprises speaker 767 which may be activated to sound an alarm when base station unit 760 receives one or more signals indicating that (1) the child's breathing is irregular or has stopped, or (2) the child's heartbeat is irregular or has stopped, or (3) the child's breathing is not being monitored, or (4) the child's heartbeat is not being monitored, or (5) the battery voltage level is too low. Base station unit 760 is to be placed where the one of the child's parents can hear the alarm whenever the alarm sounds.

[0097] In this manner, the child's care giver can immediately respond to the alarm to determine what condition exists. If the child is in physiological distress, the child's care giver can immediately attempt to relieve that distress. For example, if the child has ceased breathing, the care giver could immediately administer cardiopulmonary resuscitation (CPR) to the child. If the alarm indicates a low battery or failure of monitoring function, remedial steps can be taken immediately.

[0098] In one advantageous embodiment of physiological condition monitor 700, a monitor housing 800 contains low frequency microphone sensor 100, low bandpass filter 710, high bandpass filter 720, processor unit 730, battery 735, transmitter 740 and antenna 750. An advantageous embodiment of monitor housing 800 will be described in connection with FIGS. 8 to 21. Monitor housing 800 is capable of being coupled to a belt, harness or item of clothing that may be worn by the child being monitored. In this embodiment of physiological condition monitor 700 the movements of the child being monitored are not restricted.

[0099] In an alternate advantageous embodiment of physiological condition monitor 700 processor unit 730 is coupled to recording device 770. Processor unit 730 sends digitally encoded signals from low band pass filter 710 and digitally encoded signals from high band pass filter 720 to recording device 770. Recording device 770 is preferably a non-volatile data storage device such as a magnetic tape recorder

or a flash memory data storage card. A non-volatile data storage device is a device that retains the data stored in it when external power to the device is shut off.

[0100] In an additional advantageous embodiment of physiological condition monitor 700 processor unit 730 is coupled to network interface unit 780. Network interface unit 780 is capable of being coupled to a computer network such as a local area network (LAN), or a wide area network (WAN), or the Internet. The connection of network interface unit 780 to a computer network may be a wired connection or wireless connection.

[0101] In FIG. 7 network interface unit 780 is shown coupled to the Internet 790 via an Internet protocol router 785. Processor unit 730 sends digitally encoded signals from low band pass filter 710 and digitally encoded signals from high band pass filter 720 to network interface unit 780. Network interface unit 780 adapts the data to be transmitted via Internet protocol router 785 to the Internet 790. In this manner the data can be sent to medical monitoring station 795 at a remote location. Medical monitoring station 795 can be located in a hospital, a doctor's office, a clinic, a care giver facility, or any similar type of location.

[0102] In an alternate advantageous embodiment of physiological condition monitor 700 processor unit 730 is not coupled to transmitter 740 and to antenna 750. Instead processor unit 730 is coupled directly by wire to a wired base station unit (not shown) of the type described above. The wired base station unit is usually located in a console by the child's bed. As in the previously described case of base station unit 760, the wired base station unit is capable of displaying and analyzing digitally encoded signals from processor unit 730. The wired base station unit is capable of sounding an alarm if an analysis of the digitally encoded signals indicates an abnormal condition in the child. In this embodiment the wires coupling the physiological condition monitor 700 to the wired base unit do restrict the movements of the child.

[0103] FIGS. 8 through 21 depict an advantageous embodiment of monitor housing 800 of physiological condition monitor 700 that is shown in FIG. 7. FIG. 8 shows a perspective top view of monitor housing 800. FIG. 9 shows a perspective bottom view of monitor housing 800. The top half of monitor housing 800 comprises a top housing 810 and the bottom half of monitor housing 800 comprises a bottom housing 820. As shown in FIG. 8 and FIG. 9, top housing 810 and bottom housing 820 fit together to enclose the elements of physiological condition monitor 700. Top housing 810 and bottom housing 820 are formed having portions that define a cavity within monitor housing 800 to receive battery 735 that is shown in FIG. 7. In this embodiment battery 735 is a flat, cylindrically symmetrical, coin-shaped battery of the type commonly used in cameras and other portable electronic equipment.

[0104] Bottom housing 820 is formed having portions that receive a battery door 830 that may be opened and closed to allow access to place and remove battery 735 within the interior of monitor housing 800. Battery door 830 is pivotally connected to bottom housing 820 and may be opened and closed by pivotally moving battery door 830 with respect to bottom housing 820. Battery door 830 is shown in closed position in FIG. 9.

[0105] The outer surface of membrane 430 of low frequency microphone sensor 100 is also shown in FIG. 9. In

this advantageous embodiment of the present invention, membrane 430 (and cavity 440) has a geometrically irregular shape. The shape generally comprises two curves of different radii spaced apart and bounded on the ends by relatively flat surfaces.

[0106] FIG. 10 shows an exploded view of monitor housing 800. Top housing 810 has portions that receive a pivotal hinge boss 1010 and allow hinge boss 1010 to rotate. Hinge boss 1010 pivotally couples battery door 830 to top housing 810 and bottom housing 820. Battery door 830 is formed having portions that define a passageway 1020 through battery door 830 for receiving the lower end of hinge boss 1010. After the lower end of hinge boss 1010 has been placed through passageway 1020 of battery door 830, retaining ring 1030 fastens battery door 830 to hinge boss 1010.

[0107] In FIG. 10 battery 735 is shown in position within monitor housing 800. Battery support plate 1040 covers the top of battery 735 and only the lower edge of battery 735 is visible in FIG. 10. Two battery retaining pins 1050 are placed along the interior of bottom housing 820 to keep battery 735 in its place within monitor housing 800 and to contact the positive and negative terminals of battery 735.

[0108] Microphone 110 of low frequency microphone sensor 100 is shown in FIG. 10. To support microphone 110 within the structure of monitor housing 800 microphone 0.110 is placed through microphone sleeve 1060. In this advantageous embodiment of the invention microphone 110 extends through an aperture 1070 in the bottom of chamber 120 and extends into cavity 440. The interior of chamber 120 and cavity 440 are not visible in FIG. 10.

[0109] Printed circuit board 1080 supports the electronic circuitry of physiological condition monitor 700 that has been previously described. Lens 1090 is provided to permit a signal light such as a light emitting diode (not shown) to send signals concerning the operational status of physiological condition monitor 700.

[0110] FIG. 11 is a plan view of the top housing 810 of monitor housing 800. The location of hinge boss 1010 is shown at one corner of top housing 810. Also shown are the locations of four passageways 1110 for receiving fasteners such as screws (not shown) for fastening top housing 810 to bottom housing 820. The location of lens 1090 is also shown. The rectangles that are shown in dotted outline in the center of the plan view of top housing 810 represent the locations of electronic circuitry (such as processor unit 730) that are mounted on underlying printed circuit board 1080. The two circles that are visible in the center of the plan view of top housing 810 represent the locations of two receptacles 1120 for receiving fasteners such as screws (not shown) for printed circuit board 1080 to top housing 810.

[0111] FIG. 12 is a plan view of bottom of the assembled monitor housing 800. The location of hinge boss 1010 and retaining ring 1030 is shown at one corner of bottom housing 820. Battery door 830 is shown in its closed position. Also shown are the locations of four passageways 1110 for receiving fasteners such as screws (not shown) for fastening top housing 810 to bottom housing 820. The rectangles that are shown in dotted outline in the center of bottom housing 820 represent the locations of electronic circuitry (such as processor unit 730) that are mounted on underlying printed circuit board 1080. The location of microphone 110 within

cavity 440 is also shown. Membrane 430 (not shown in FIG. 12) covers the top of cavity 440.

[0112] FIG. 13 is a cross sectional view of top housing 810 of monitor housing 800 taken along line 13-13 of FIG. 11. A side view of receptacle 1120 is shown. Because the line 13-13 takes a right angle turn, only one receptacle 1110 is shown. FIG. 14 is a cross sectional view of top housing 810 of monitor housing 800 taken along line 14-14 of FIG. 11. Both receptacles 1320 are shown. Also shown is the location of hinge boss 1010.

[0113] FIG. 15 is a plan view of bottom housing 820 of monitor housing 800. The location of microphone 110 is shown. Also shown in the location and shape of membrane 430 and the underlying cavity 440 (not shown in FIG. 15). The location of fastener receptacles 1110 are also shown. The circular area 1510 shows the location of battery 735 (not shown in FIG. 15) within monitor housing 800. Oblong area 1520 shows the location of battery door 830 (also not shown in FIG. 15).

[0114] FIG. 16 is a side elevation view of bottom housing 820 of monitor housing 800 taken along line 16-16 of FIG. 15. A portion of the bottom of bottom housing 820 is covered with membrane 430. The location of cavity 440 in bottom housing 820 is shown. Also shown is the location of microphone 110 and fastener receptacles 1110. FIG. 17 is an end elevation view of bottom housing 820 of monitor housing 800 taken along line 17-17 of FIG. 15. FIG. 17 also shows the location of membrane 430, cavity 440 and microphone 110.

[0115] FIG. 18 is a plan view of battery door 830 of monitor housing 800. The shape of battery door 830 fits the oblong area 1520 shown in FIG. 15. As previously mentioned, battery door 830 is formed having portions that define a passageway 1020 through battery door 830 for receiving the lower end of hinge boss 1010. Passageway 1020 is shown in FIG. 18. Also shown is latch 1810 for latching battery door 830 after it has been closed. FIG. 19 is a side elevation view of battery door 830 of monitor housing 800 taken along line 19-19 of FIG. 18. FIG. 20 is an end elevation view of battery door 830 of monitor housing 800 taken along line 20-20 of FIG. 18.

[0116] FIG. 21 is a perspective bottom view of monitor housing 800 of physiological condition monitor 700 showing battery door 830 in an open position and showing the placement of battery 735 in monitor housing 800. The location of microphone 110 within cavity 440 is shown. The end of hinge boss 1010 and retaining ring 1030 are also shown.

[0117] Although the present invention has been described with reference to monitoring the physiological conditions of human beings, the present invention can also be used to monitor the physiological conditions of vertebrate animals such as dogs, cats, horses, and the like.

[0118] Although the present invention has been described in detail, those skilled in the art should understand that they can make various changes, substitutions and alterations herein without departing from the spirit and scope of the invention in its broadest form.

What is claimed is:

1. An apparatus for remotely monitoring at least one physiological condition of a child by detecting very low frequency acoustic signals comprising a low frequency sensor capable of being acoustically coupled to a source of acoustic signals, said low frequency sensor capable of receiving low frequency acoustic signals in the frequency range of one tenth Hertz to thirty Hertz and generating electronic signals indicative of the intensity of said low frequency acoustic signals.

2. An apparatus as claimed in claim 1 further comprising signal processing circuitry coupled to said low frequency sensor capable of processing said electronic signals from said low frequency sensor to obtain electronic signals indicative of the intensity of said low frequency acoustic signals in the frequency range of one tenth Hertz to two Hertz.

3. An apparatus as claimed in claim 1 further comprising signal processing circuitry coupled to said low frequency sensor capable of processing said electronic signals from said low frequency sensor to obtain electronic signals indicative of the intensity of said low frequency acoustic signals in the frequency range of ten Hertz to thirty Hertz.

4. The apparatus as claimed in claim 1 wherein said low frequency sensor comprises:

a chamber capable of being acoustically coupled to a source of acoustic signals, said chamber having portions that define a cavity within said chamber;

a microphone capable of receiving low frequency acoustic signals within said cavity of said chamber in the frequency range of one tenth Hertz to thirty Hertz and capable of generating electronic signals indicative of the intensity of said low frequency acoustic signals.

5. The apparatus as claimed in claim 4 wherein said chamber is a closed chamber filled with fluid.

6. The apparatus as claimed in claim 5 wherein said fluid is air.

7. The apparatus as claimed in claim 4 wherein said chamber is an open chamber filled with air.

8. The apparatus as claimed in claim 4 wherein said chamber is formed having nonrigid walls.

9. The apparatus as claimed in claim 8 wherein said nonrigid walls are capable of moving inwardly and outwardly with respect to the interior of said cavity in response to the presence of low frequency acoustic energy.

10. An apparatus as claimed in claim 4 further comprising signal processing circuitry coupled to said microphone capable of processing said electronic signals from said microphone to obtain electronic signals indicative of the intensity of said low frequency acoustic signals in the frequency range of one tenth Hertz to two Hertz.

11. An apparatus as claimed in claim 4 further comprising signal processing circuitry coupled to said microphone capable of processing said electronic signals from said microphone sensor to obtain electronic signals indicative of the intensity of said low frequency acoustic signals in the frequency range of ten Hertz to thirty Hertz.

12. An apparatus for remotely monitoring at least one physiological condition of a child by detecting very low frequency acoustic signals comprising an apparatus capable of detecting very low frequency acoustic signals in the frequency range of one tenth Hertz to thirty Hertz comprising:

- a chamber capable of being acoustically coupled to a source of acoustic signals, said chamber having portions that define a cavity within said chamber, and said chamber having nonrigid walls capable of moving inwardly and outwardly with respect to the interior of said cavity in response to the presence of low frequency acoustic energy; and
- a microphone placed within said cavity of said chamber capable of receiving low frequency acoustic signals within said cavity of said chamber that are caused by the inward and outward motion of said nonrigid walls of said cavity, and capable of generating electronic signals indicative of the intensity of said low frequency acoustic signals.
- 13.** The apparatus as claimed in claim 4 further comprising:
- a membrane attached to said chamber covering said cavity of said chamber, said membrane capable of moving in response to very low frequency acoustic signals incident on said membrane to cause said very low frequency acoustic signals to be transmitted through said cavity to said microphone.
- 14.** The apparatus as claimed in claim 13 wherein the movements of said membrane amplify the intensity of said very low frequency acoustic signals, within said cavity.
- 15.** The apparatus as claimed in claim 14 wherein said movements of said membrane amplify the intensity of said very low frequency acoustic signals within said cavity by causing said very low frequency acoustic signals to resonate within said cavity.
- 16.** An apparatus as claimed in claim 13 further comprising signal processing circuitry coupled to said microphone capable of processing said electronic signals from said microphone to obtain electronic signals indicative of the intensity of said low frequency acoustic signals in the frequency range of one tenth Hertz to two Hertz.
- 17.** An apparatus as claimed in claim 13 further comprising signal processing circuitry coupled to said microphone capable of processing said electronic signals from said microphone sensor to obtain electronic signals indicative of the intensity of said low frequency acoustic signals in the frequency range of ten Hertz to thirty Hertz.
- 18.** The apparatus as claimed in claim 12 further comprising:
- a membrane attached to said chamber covering said cavity of said chamber, said membrane capable of moving in response to very low frequency acoustic signals incident on said membrane to cause said very low frequency acoustic signals to be transmitted through said cavity to said microphone.
- 19.** The apparatus as claimed in claim 18 wherein the movements of said membrane amplify the intensity of said very low frequency acoustic signals within said cavity.
- 20.** The apparatus as claimed in claim 19 wherein said movements of said membrane amplify the intensity of said very low frequency acoustic signals within said cavity by causing said very low frequency acoustic signals to resonate within said cavity.
- 21.** A physiological condition monitor for remotely monitoring at least one physiological condition of a child by detecting very low frequency acoustic signals of the child comprising:
- a sensor capable of being acoustically coupled to the body of the child being monitored and capable of receiving low frequency acoustic signals in the range of one tenth Hertz to thirty Hertz and capable of generating electronic signals indicative of the intensity of said low frequency acoustic signals; and
- a low bandpass filter coupled to said sensor capable of processing said electronic signals from said sensor to obtain digitally encoded electronic signals indicative of the intensity of said low frequency acoustic signals in the frequency range of one tenth Hertz to two Hertz, said digitally encoded electronic signals being indicative of respiration activity of the child being monitored.
- 22.** The physiological condition monitor claimed in claim 21 further comprising:
- a high bandpass filter coupled to said sensor capable of processing said electronic signals from said sensor to obtain digitally encoded electronic signals indicative of the intensity of said low frequency acoustic signals in the frequency range of ten Hertz to thirty Hertz, said digitally encoded electronic signals being indicative of cardiac activity of the child being monitored.
- 23.** The physiological condition monitor claimed in claim 22 further comprising:
- a processor unit, said processor unit coupled to said low bandpass filter capable of receiving said digitally encoded electronic signals from said low bandpass filter indicative of said respiration activity, and said processor unit coupled to said high bandpass filter capable of receiving said digitally encoded electronic signals from said high bandpass filter indicative of said cardiac activity; and
- a recording device associated with said processor unit capable of receiving from said processor unit digitally encoded electronic signals representative of at least one physiological condition and capable of recording said electronic signals.
- 24.** The physiological condition monitor as claimed in claim 23 further comprising a transmitter coupled to said processor unit capable of receiving digitally encoded electronic signals indicative of at least one physiological condition, said transmitter including an antenna for transmitting said digitally encoded electronic signals received from said processor unit.
- 25.** A sensor capable of obtaining low frequency acoustic signals from a child without being directly coupled to the skin of the child, said sensor comprising:
- a chamber having portions that define a cavity within said chamber, said chamber capable of being acoustically coupled to low frequency acoustic signals of the child;
- a microphone placed within said cavity of said chamber, said microphone capable of receiving low frequency acoustic signals in the frequency range of one tenth Hertz to thirty Hertz and generating electronic signals indicative of the intensity of said low frequency acoustic signals received by said microphone; and
- a membrane attached to said chamber covering said cavity of said chamber, said membrane capable of moving in response to very low frequency acoustic signals incident upon said membrane to cause said very low frequency acoustic signals to be transmitted through

- said cavity to said microphone, said membrane capable of being acoustically coupled to said low frequency acoustic signals of the child without directly contacting the skin of the child.
- 26.** A method for detecting very low frequency acoustic signals comprising the steps of:
- acoustically coupling a low frequency sensor to a source of low frequency acoustic signals;
 - receiving in said low frequency sensor acoustic signals in the range of one tenth Hertz to thirty Hertz; and
 - generating in said low frequency sensor electronic signals indicative of the intensity of said low frequency acoustic signals.
- 27.** A method as claimed in claim 26 further comprising the step of:
- processing said electronic signals from said low frequency sensor with signal processing circuitry; and
 - obtaining electronic signals indicative of the intensity of said low frequency acoustic signals in the frequency range of one tenth Hertz to two Hertz.
- 28.** A method as claimed in claim 26 further comprising the step of:
- processing said electronic signals from said low frequency sensor with signal processing circuitry; and
 - obtaining electronic signals indicative of the intensity of said low frequency acoustic signals in the frequency range of ten Hertz to thirty Hertz.
- 29.** A method for detecting low frequency acoustic signals comprising the steps of:
- forming a chamber having portions that define a cavity within said chamber;
 - placing a microphone within said cavity of said chamber;
 - acoustically coupling said chamber to a source of low frequency acoustic signals;
 - receiving in said microphone acoustic signals in the range of one tenth Hertz to thirty Hertz; and
 - generating in said microphone electronic signals indicative of the intensity of said low frequency acoustic signals.
- 30.** A method as claimed in claim 29 comprising the further steps of:
- forming the walls of said chamber with nonrigid material capable of moving inwardly and outwardly with respect to the interior of said cavity in response to the presence of low frequency acoustic energy; and
 - receiving in said microphone acoustic signals in the range of one tenth Hertz to thirty Hertz within said cavity of said chamber that are caused by the inward and outward motion of said nonrigid walls of said cavity.
- 31.** A method for detecting low frequency acoustic signals comprising the steps of:
- forming a chamber having portions that define a cavity within said chamber;
 - placing a microphone within said cavity of said chamber;
 - attaching a membrane to said chamber wherein said membrane covers said cavity of said chamber and wherein said membrane is capable of moving in response to very low frequency acoustic signals incident on said membrane;
 - acoustically coupling said membrane to a source of low frequency acoustic signals;
 - receiving in said microphone acoustic signals in the range of one tenth Hertz to thirty Hertz within said cavity of said chamber that are caused by the movements of said membrane; and
 - generating in said microphone electronic signals indicative of the intensity of said low frequency acoustic signals.
- 32.** A method as claimed in claim 31 comprising the further steps of:
- amplifying said low frequency acoustic signals within said cavity of said chamber; and
 - receiving in said microphone said amplified acoustic signals in the range of one tenth Hertz to thirty Hertz.
- 33.** A method for detecting low frequency acoustic signals comprising the steps of:
- forming a chamber having portions that define a cavity within said chamber;
 - placing a microphone within said cavity of said chamber;
 - attaching a membrane to said chamber covering said cavity of said chamber;
 - acoustically coupling said membrane to a source of acoustic signals;
 - receiving in said microphone low frequency acoustic signals in the range of one tenth Hertz to thirty Hertz; and
 - generating in said microphone electronic signals indicative of the intensity of said low frequency acoustic signals.
- 34.** The method as claimed in claim 33 further comprising the steps of:
- coupling a low bandpass filter to said microphone capable of processing said electronic signals from said microphone;
 - obtaining digitally encoded electronic signals indicative of the intensity of said low frequency acoustic signals in the frequency range of one tenth Hertz to two Hertz;
 - coupling a high bandpass filter to said microphone capable of processing said electronic signals from said microphone; and
 - obtaining digitally encoded electronic signals indicative of the intensity of said high frequency acoustic signals in the frequency range of ten Hertz to thirty Hertz.
- 35.** The method as claimed in claim 34 further comprising the steps of:
- coupling a processor unit to said low bandpass filter and to said high bandpass filter;
 - receiving in said processor unit said digitally encoded electronic signals from said low bandpass filter;

receiving in said processor unit said digitally encoded electronic signals from said high bandpass filter;
coupling a recording device to said processor unit; and
receiving in said recording device said digitally encoded electronic signals from said processor unit; and
recording in said recording device said digitally encoded electronic signals.

36. The method-as claimed in claim 33 further comprising the steps of:

acoustically coupling said membrane to low frequency acoustic signals of a child; and
positioning said membrane so that said membrane does not contact the skin of the child.

* * * * *

专利名称(译)	用于远程监控儿童的至少一个生理特征的系统和方法		
公开(公告)号	US20050065457A1	公开(公告)日	2005-03-24
申请号	US10/801108	申请日	2004-03-15
[标]申请(专利权)人(译)	关爱TECH		
申请(专利权)人(译)	CARING TECHNOLOGIES, INC.		
当前申请(专利权)人(译)	CARING TECHNOLOGIES, INC.		
[标]发明人	HALLECK MICHAEL E HALLECK MICHAEL D LEHRMAN MICHAEL L		
发明人	HALLECK, MICHAEL E. HALLECK, MICHAEL D. LEHRMAN, MICHAEL L.		
IPC分类号	A61B5/00 A61B7/00 A61B7/04		
CPC分类号	A61B5/0002 A61B2562/0204 A61B7/04 A61B7/003		
外部链接	Espacenet USPTO		

摘要(译)

公开了一种用于通过检测极低频声信号来远程监控儿童的至少一种生理状况的系统和方法。该装置包括能够检测在十分之一赫兹到三十赫兹的频率范围内的低频声信号的传感器。传感器包括腔室，腔室具有形成腔的部分和放置在腔内的低频麦克风。本发明的另一个实施例包括具有形成谐振腔的部分的腔室，安装在谐振腔中的麦克风，以及覆盖谐振腔的膜。入射在膜上的低频声信号使膜移动并放大谐振腔内的声信号。传感器提供有关儿童生理状况的信息，例如呼吸和心脏活动。生理状态监测器中的传感器不需要直接耦合到被监测儿童的皮肤。

