



(19) **United States**

(12) **Patent Application Publication** (10) **Pub. No.: US 2003/0036708 A1**

Guendel

(43) **Pub. Date: Feb. 20, 2003**

(54) **METHOD FOR RESPIRATION-DEPENDENT TRIGGERING OF A MEDICAL IMAGE EXPOSURE**

(30) **Foreign Application Priority Data**

Jul. 31, 2001 (DE)..... 10137170.5

Publication Classification

(76) **Inventor: Lutz Guendel, Erlangen (DE)**

(51) **Int. Cl.⁷ A61B 5/00**

(52) **U.S. Cl. 600/534; 600/300**

Correspondence Address:
SCHIFF HARDIN & WAITE
6600 SEARS TOWER
233 S WACKER DR
CHICAGO, IL 60606-6473 (US)

(57) **ABSTRACT**

In a method for respiration-dependent triggering of a data acquisition event in an imaging procedure, a navigation system is employed in order to reproduce the position of a body part moving due to respiration on a scale, particularly a linear scale. Triggering for the exposure of an image ensues at prescribed positions of a pointer relative to the scale, i.e. at prescribed scale values.

(21) **Appl. No.: 10/210,629**

(22) **Filed: Jul. 31, 2002**

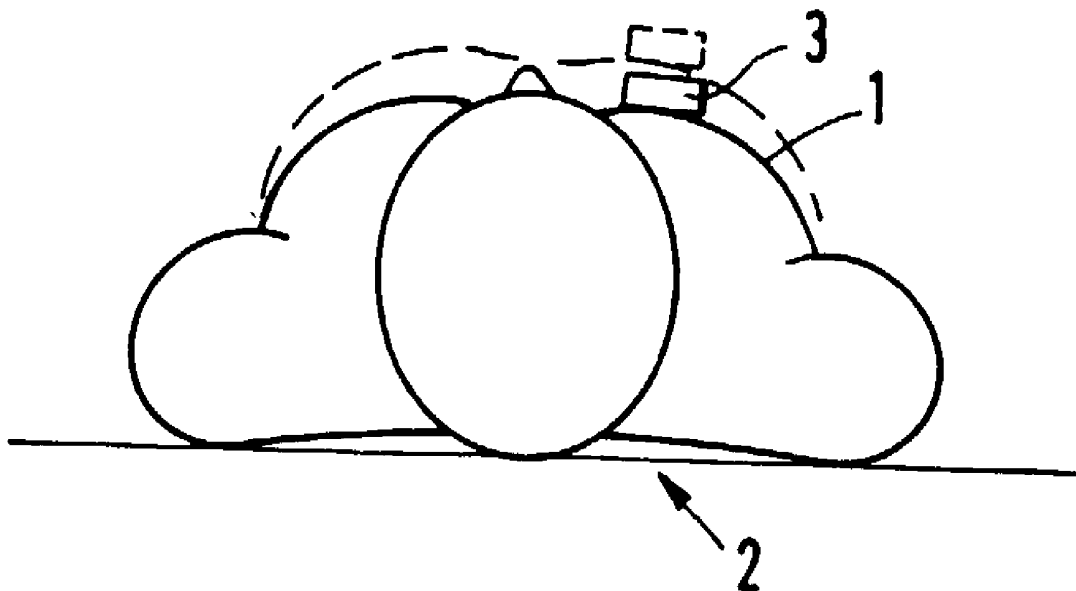

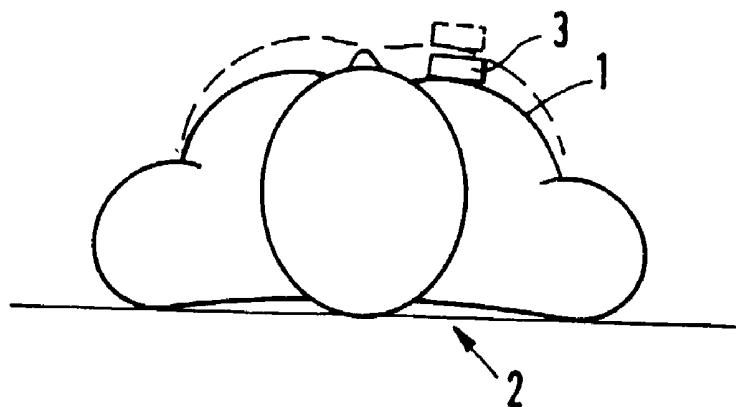

FIG. 1

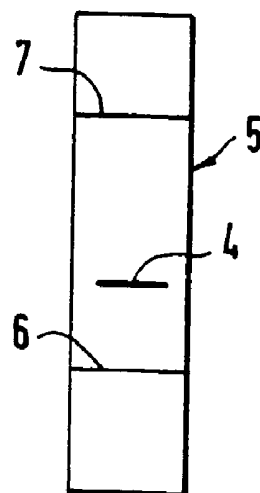

FIG. 2

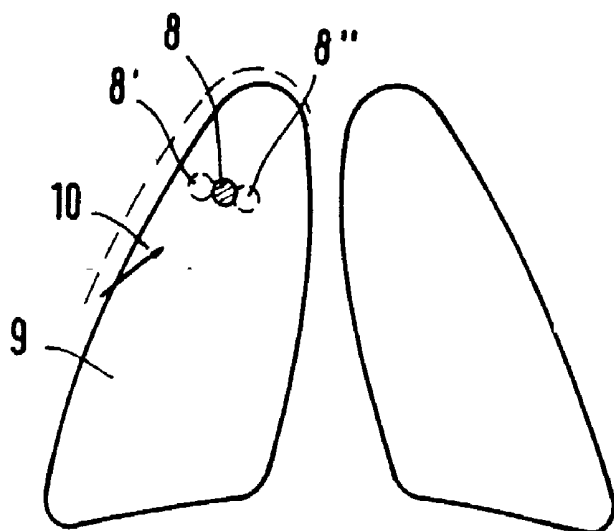

FIG. 3

METHOD FOR RESPIRATION-DEPENDENT TRIGGERING OF A MEDICAL IMAGE EXPOSURE

BACKGROUND OF THE INVENTION

[0001] 1. Field of the Invention

[0002] The present invention is directed to a method for triggering generation of an image of a subject dependent on respiration of the subject.

[0003] 2. Description of the Prior Art

[0004] Many imaging methods in medicine such as, for example, computed tomography and magnetic resonance assume a non-moving subjects in the data acquisition measurement. Motion such as, for example, respiration leads to image artifacts. In an intervention with an imaging method wherein, for example, a needle must be guided to a small structure in the body, this leads to the fact that the target cannot be hit or cannot be reliably hit in the first attempt. This leads to a lengthening of the intervention and thus to a higher complication rate.

[0005] Attempts are therefore made in the biopsy of the lung to reliably hit the target during respiration pauses of the patient and under supervision with the imaging method. The image monitoring requires additional time and produces an additional radiation stress on the patient given employment of ionizing rays such as, for example in a computed tomography system. Given uncooperative patients, unconscious patients or children, this method cannot be employed, and full anesthesia with ventilation must be used, with associated risks.

[0006] Another alternative is to control of the respiration and/or the imaging method by means of a spirometer, but this is likewise rather complicated.

SUMMARY OF THE INVENTION

[0007] An object of the present invention is to provide a method for respiration dependent triggering of a data acquisition event in an imaging procedure that enables artifact-free, reproducible images as well as unproblematical interventions regardless of the cooperation of the patient.

[0008] For achieving this object a navigation system is inventively employed in order to reproduce the position of a body part moving due to respiration on a scale, particularly a linear scale, and a triggering for the exposure (data gathering event) of an image ensues at prescribed positions on the scale, i.e. at prescribed scale values.

[0009] In a very simple way, the inventive method assures that an image exposure, particularly repeated image exposures as well, always occur in the same motion stage (phase). The start of the scale can, for example, represent the exhaled condition, the end of the scale can represent the inhaled condition and a pointer can represent the momentary respiration position. By observing the migrating pointer along the scale an operator can trigger an exposure at any arbitrarily, prescribed point in time, i.e. in the exhaled or in the inhaled condition or in an intermediate stage. Of course, such triggering can ensue automatically at a prescribed point on the scale with electronic or computerized monitoring of the migrating pointer. In order to produce the scale, a marker can be secured to the body of the patient in the simplest case, the respective position of the marker being displayed on the scale.

[0010] The inventive respiration-triggering method is particularly suited for interventions at a moving body, for example for biopsies or the like. To this end, the intervention is implemented after the production of a respiration-triggered image, possibly in steps, at the same time in a subsequent motion cycle of which the production of the image occurred in a previous cycle, while targeting the fixed target point of the still image.

[0011] In the simplest case, the angle and, possibly, the distance from the known starting position of the intervention instrument, particularly a biopsy needle, are initially measured in the image. The appropriate displacement of the intervention instrument subsequently ensues at the same triggering time (in a subsequent cycle) at which the image was produced.

[0012] In an embodiment of the invention the tip of the intervention instrument is continuously identified via a position acquisition system and is mixed into the stationary, triggered image, and a displacement of the intervention instrument in the still image with the mixed-in instrument position ensues at the triggering time, i.e. at the same scale position at which the image was registered.

DESCRIPTION OF THE DRAWINGS

[0013] FIG. 1 is a schematic illustration of a prone patient registered as seen from the head, with a marker secured to the chest for implanting the inventive method.

[0014] FIG. 2 is an illustration of a scale having a pointer reproducing the position of the marker that moves between two limit values for the inhaled and the exhaled condition.

[0015] FIG. 3 is a schematic illustration of a lung with a tumor that is displaced during respiration and that is to be punctured by a biopsy needle.

DESCRIPTION OF THE PREFERRED EMBODIMENTS

[0016] A marker 3 is secured on the chest 1 of the patient 2 shown in FIG. 1, the position of the marker 3 being acquired with a position acquisition system and being indicated or seen as movement of a pointer 4 along a scale 5. The pointer 4 moves between the limit positions 6 and 7 that correspond respectively to the exhaled and the inhaled conditions. A triggering of the imaging system ensues either manually or automatically at an arbitrary point in time, at the exhaled criterion, at the inhaled condition or at a prescribed intermediate time, so that a series of comparable exposures can be produced respectively at the same motion stage in each of a number of motion cycles.

[0017] The inventive triggering method is particularly suited for an intervention, for example a biopsy of a tumor 8 on a lobe 9 of the lung, whereby this tumor 8 moves between the broken-line positions 8' and 8'' during respiration. In order nonetheless to be able to implement a simple intervention, i.e. a simple biopsy, an exposure wherein the tumor 8 is in the solid-line position in FIG. 3 is first made at a specific, prescribed respiration condition—the inhaled or the exhaled position is preferred but an intermediate position also can be selected given a difficult position that is hard to recognize. The tip 10 of the intervention instrument, i.e., for example, of the biopsy needle, is continuously identified via a position acquisition system and this position

is mixed into the stationary, triggered image according to **FIG. 3**. At the same triggering time (in a subsequent cycle) at which the image was made, i.e. at the same position of the pointer **4** on the scale **5**, the instrument is displaced to the tumor **8** in the image, since it is known that the tumor is located exactly in this position at this trigger time even though no image observation at all is ensuing at the current moment. In the case of complicated interventions or biopsies, the displacement can ensue in steps, with each brief-duration displacement step always occurring at the trigger time (in a subsequent cycle) of the production of the image.

[0018] Although modifications and changes may be suggested by those skilled in the art, it is the intention of the inventor to embody within the patent warranted hereon all changes and modifications as reasonably and properly come within the scope of his contribution to the art.

I claim as my invention:

1. A method for respiration-dependent triggering of production of a medical image, comprising the steps of:

designating a position relative to a scale of a body part of a subject moving due to respiration of the subject; and

triggering at least one data acquisition event for obtaining an image of said subject when said designation of said body part is at a prescribed position relative to said scale.

2. A method as claimed in claim 1 comprising employing a linear scale as said scale.

3. A method as claimed in claim 1 comprising employing a scale having a plurality of scale values, and wherein the step of triggering said at least one data acquisition event comprises triggering said at least one data acquisition event when said designation of said movement of said body part is at a predetermined scale value.

4. A method as claimed in claim 1 wherein the step of designating the position of said body part moving due to

respiration on a scale comprises securing a marker to said body part and indicating a position of said marker on said scale.

5. A method as claimed in claim 1 comprising the additional steps of:

introducing an intervention instrument into said subject toward a fixed target point in said image; and

triggering said introduction of said intervention instrument, in a subsequent motion cycle of said subject, when said designation of said body part in said subsequent cycle is at said prescribed position relative to said scale.

6. A method as claimed in claim 5 comprising introducing said intervention instrument into said subject in a plurality of successive steps, and initiating each of said plurality of successive steps, in respective subsequent motion cycles of said subject, when said designation of the position of said body part is at said prescribed position relative to said scale.

7. A method as claimed in claim 5 wherein said intervention instrument has a tip, and identifying an angle of said tip in said image relative to said starting position.

8. A method as claimed in claim 7 comprising additionally determining a distance of said tip from said known starting position.

9. A method as claimed in claim 7 comprising continuously monitoring and identifying a position of said tip of said intervention instrument using a position acquisition system and mixing a designation of said tip into said image and, in respective subsequent motion cycles of said subject, briefly displacing said intervention instrument into said subject when said designation of said body part is at said prescribed position relative to said scale.

* * * * *

专利名称(译)	用于呼吸依赖性触发医学图像曝光的方法		
公开(公告)号	US20030036708A1	公开(公告)日	2003-02-20
申请号	US10/210629	申请日	2002-07-31
[标]申请(专利权)人(译)	GUENDEL LUTZ		
申请(专利权)人(译)	GUENDEL LUTZ		
当前申请(专利权)人(译)	SIEMENS AKTIENGESELLSCHAFT		
[标]发明人	GUENDEL LUTZ		
发明人	GUENDEL, LUTZ		
IPC分类号	A61B5/055 A61B5/113 A61B6/00 A61B5/00		
CPC分类号	A61B5/055 A61B5/1135 A61B5/7285 A61B6/541		
优先权	10137170 2001-07-31 DE		
其他公开文献	US7035683		
外部链接	Espacenet USPTO		

摘要(译)

在用于在成像过程中依赖于呼吸的触发数据采集事件的方法中，采用导航系统以再现由于呼吸在体重上移动的身体部位的位置，特别是线性标度。触发图像的曝光在指针相对于标尺的规定位置处，即在规定的标度值处进行。

