



US009408537B2

(12) **United States Patent**
Schroeter et al.

(10) **Patent No.:** **US 9,408,537 B2**
(45) **Date of Patent:** **Aug. 9, 2016**

(54) **SYSTEM AND METHOD FOR PERFORMING
A DIAGNOSTIC ANALYSIS OF
PHYSIOLOGICAL INFORMATION**

(75) Inventors: **Horst Schroeter**, New Providence, NJ
(US); **E-Lee Chang**, Mableton, GA
(US); **Linda Roberts**, Decatur, GA
(US); **Madhur Khandelwal**, Atlanta,
GA (US); **Darnell Clayton**, Atlanta, GA
(US)

6,425,764	B1 *	7/2002	Lamson	434/236
6,641,532	B2 *	11/2003	Iliff	600/300
8,469,713	B2 *	6/2013	Kron et al.	434/238
2002/0065682	A1 *	5/2002	Goldenberg	705/2
2002/0107824	A1 *	8/2002	Ahmed	706/46
2004/0002634	A1 *	1/2004	Nihtila	600/300
2004/0121295	A1 *	6/2004	Stuart et al.	434/262
2005/0015115	A1 *	1/2005	Sullivan et al.	607/5
2005/0223328	A1	10/2005	Ashtekar et al.	
2005/0273509	A1 *	12/2005	Brown	709/224

(Continued)

(73) Assignee: **AT&T Intellectual Property I, LP**,
Atlanta, GA (US)

OTHER PUBLICATIONS

(*) Notice: Subject to any disclaimer, the term of this patent is extended or adjusted under 35 U.S.C. 154(b) by 1292 days.

Youtube, "Apple Futureshock, Knowledge Navigator", 2 pages, <http://www.youtube.com/watch?v=3WdS4Tscwh8>, web site last visited Sep. 18, 2008.

(Continued)

(21) Appl. No.: **12/271,600**

Primary Examiner — Gary Jackson

(22) Filed: **Nov. 14, 2008**

Assistant Examiner — Davin Sands

(65) **Prior Publication Data**

(74) *Attorney, Agent, or Firm* — Guntin & Gust, PLC;
Joseph Hrutka

US 2010/0125182 A1 May 20, 2010

(51) **Int. Cl.**
G06F 19/00 (2011.01)
A61B 5/00 (2006.01)
G06N 3/00 (2006.01)

(57) **ABSTRACT**

(52) **U.S. Cl.**
CPC **A61B 5/0022** (2013.01); **A61B 5/4842**
(2013.01); **A61B 5/744** (2013.01); **G06F**
19/345 (2013.01); **G06F 19/3418** (2013.01);
G06F 19/36 (2013.01); **G06F 19/363**
(2013.01); **G06N 3/006** (2013.01)

A system that incorporates teachings of the present disclosure may include, for example, an avatar engine having a controller to retrieve a user profile of a user, present the user an avatar having characteristics that correlate to the user profile, detect one or more responses of the user during a communication exchange between the user and the avatar, identify from the one or more responses a need to determine a medical status of the user, establish communications with a medical diagnostic system, receive physiological information associated with the user, submit the physiological information to the medical diagnostic system, receive from the medical diagnostic system a diagnostic analysis of the physiological information, and present the diagnostic analysis to at least one of the user and a medical agent of the user, wherein the user is presented the diagnostic analysis by way of the avatar. Other embodiments are disclosed.

(58) **Field of Classification Search**
None
See application file for complete search history.

(56) **References Cited**

U.S. PATENT DOCUMENTS

5,437,278	A *	8/1995	Wilk	600/425
6,190,313	B1 *	2/2001	Hinkle	600/300

21 Claims, 9 Drawing Sheets

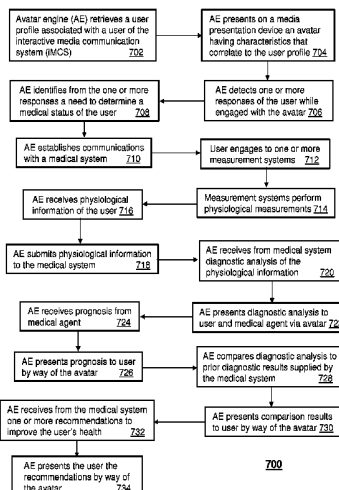

(56)

References Cited

U.S. PATENT DOCUMENTS

2006/0100018	A1 *	5/2006	Ganz	463/42
2007/0021979	A1 *	1/2007	Cosentino et al.	705/2
2007/0050715	A1 *	3/2007	Behar	715/706
2007/0074114	A1	3/2007	Adjali et al.	
2007/0129610	A1 *	6/2007	Squilla	600/300
2007/0166690	A1 *	7/2007	Johnson	434/365
2008/0052116	A1 *	2/2008	Iiliff	705/2
2008/0274755	A1 *	11/2008	Cholkar et al.	455/461
2008/0303811	A1 *	12/2008	Van Luchene	345/419
2009/0044113	A1 *	2/2009	Jones et al.	715/707
2009/0112538	A1 *	4/2009	Anderson et al.	703/6
2009/0164917	A1 *	6/2009	Kelly	715/757
2009/0254417	A1 *	10/2009	Beilby et al.	705/10
2009/0293079	A1 *	11/2009	McKee et al.	725/10
2009/0325701	A1 *	12/2009	Andres Del Valle	463/36
2010/0046806	A1 *	2/2010	Baughman et al.	382/115
2010/0070987	A1 *	3/2010	Amento et al.	725/10
2010/0121156	A1 *	5/2010	Yoo	600/300

OTHER PUBLICATIONS

- Cosatto et al., "Lifelike Talking Faces for Interactive Service", pp. 1406-1429, Proceedings of the IEEE, vol. 91, No. 9, Sep. 2003.
- Cosatto et al., "From Audio-Only to Audio and Video Text-to-Speech", pp. 1084-1095, Acta Acustica United with Acustica, vol. 90, Accepted Apr. 14, 2004.
- Secondlife, "Virtual Worlds, Avatars, 3D Chat, Online meetings", 1 page, <http://secondlife.com/> Web site last visited Oct. 20, 2008.
- Livley, "Create an Avatar and Chat with your friends in Rooms you Design", 1 page, <http://www.lively.com/html/landing.html>, Web site last visited Oct. 20, 2008.
- Usatoday.com, "Sony, Microsoft Virtual Communities to Start", 3 pages, http://www.usatoday.com/tech/gaming/2008-10-09-sony-microsoft_N.htm, Web site last visited Oct. 20, 2008.
- Xbox.com, "Welcome to the New Xbox Experience", 1 page, <http://www.xbox.com/en-us/live/nxe/>, Web site last visited Oct. 20, 2008.
- Texas Tech University Health Sciences Center, "Center for Telemedicine", 1 page, <http://www.ttuhsc.edu/telemedicine>, Web site last visited Nov. 14, 2008.

* cited by examiner

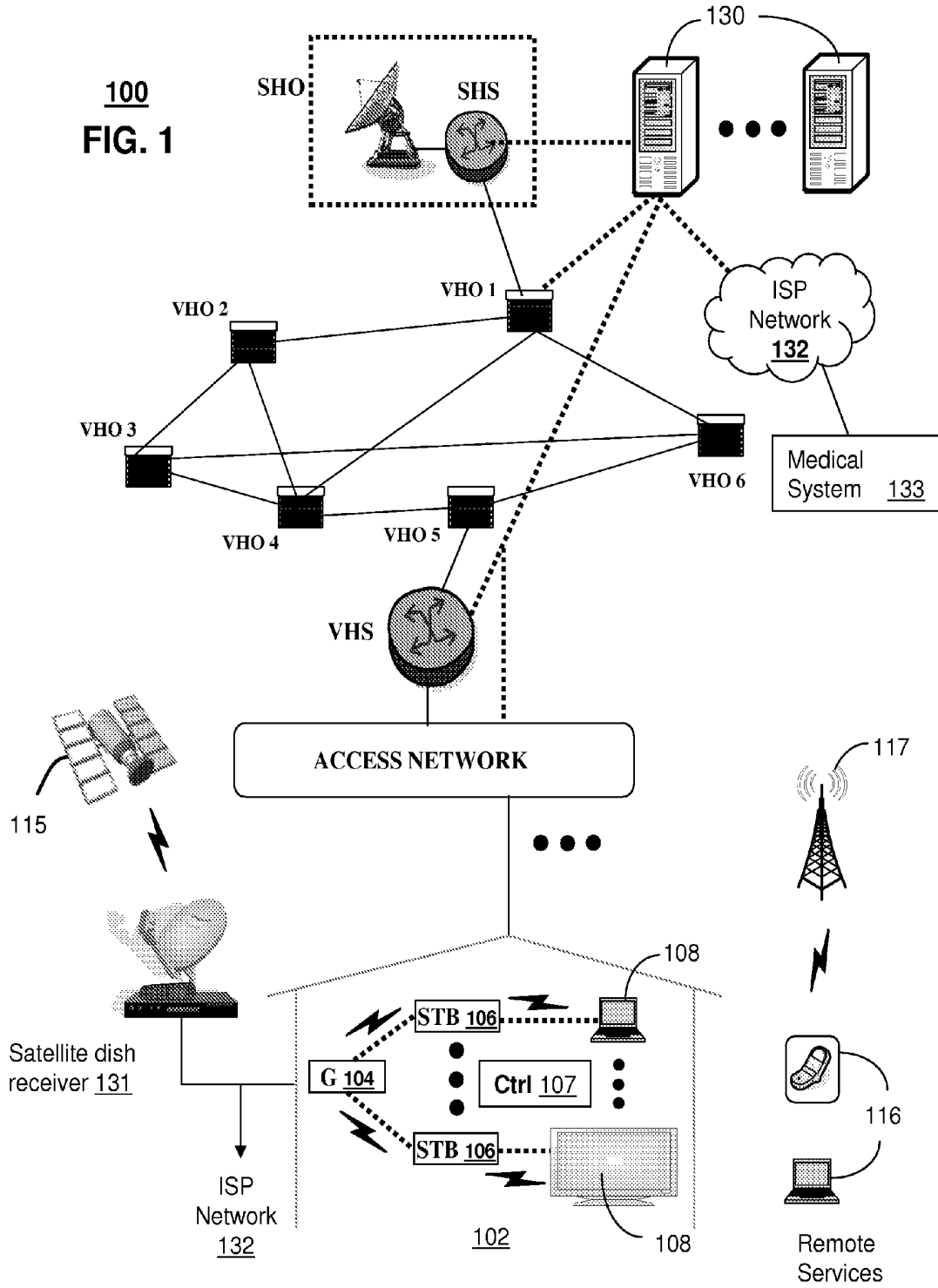

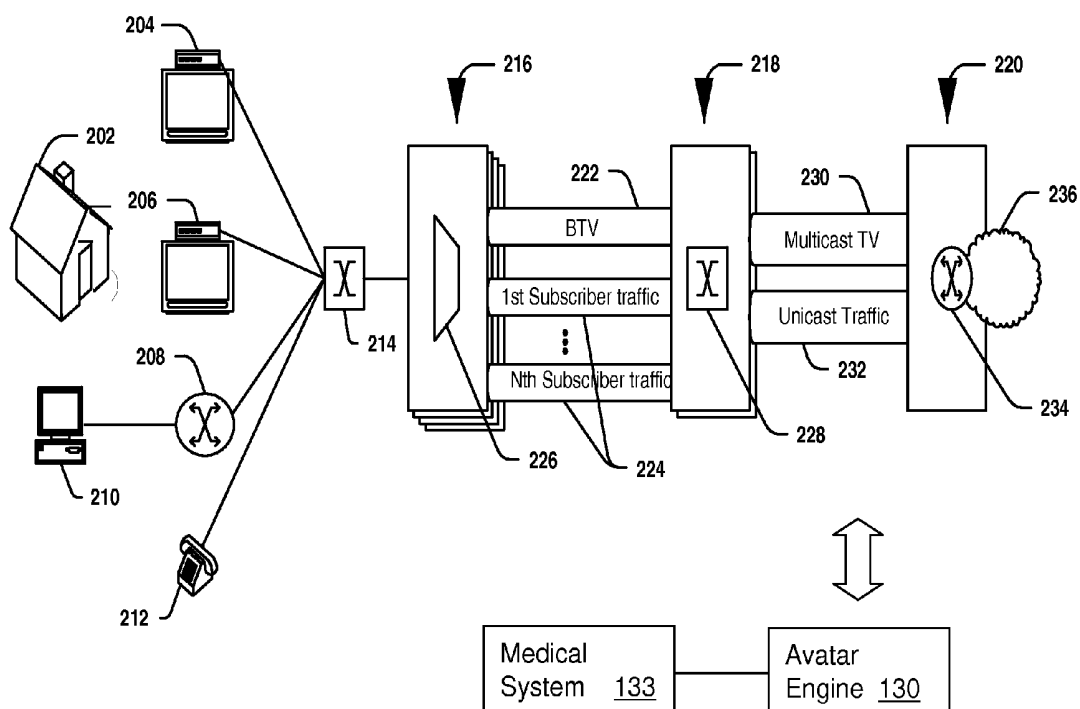

200
FIG. 2

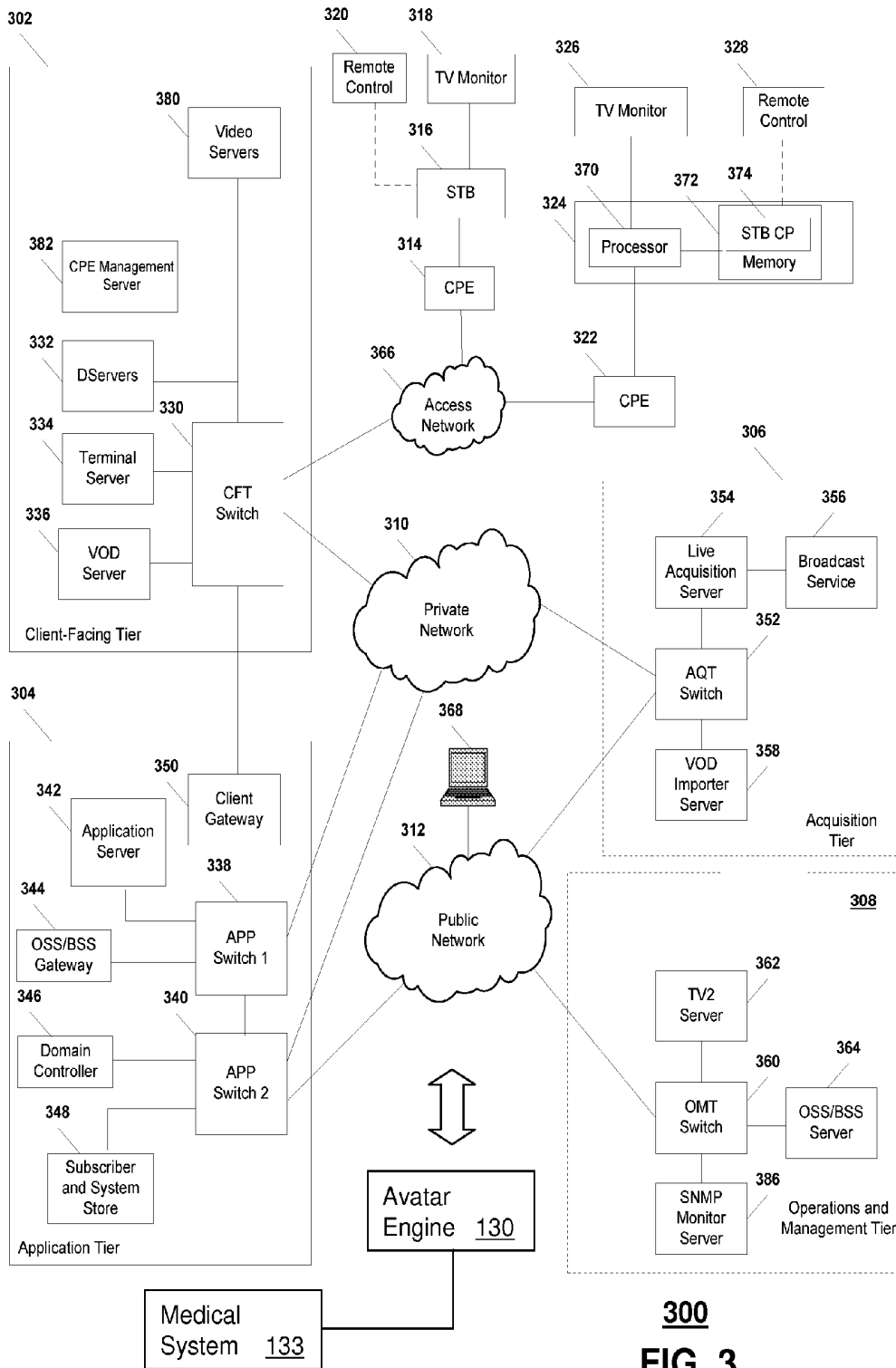

300
FIG. 3

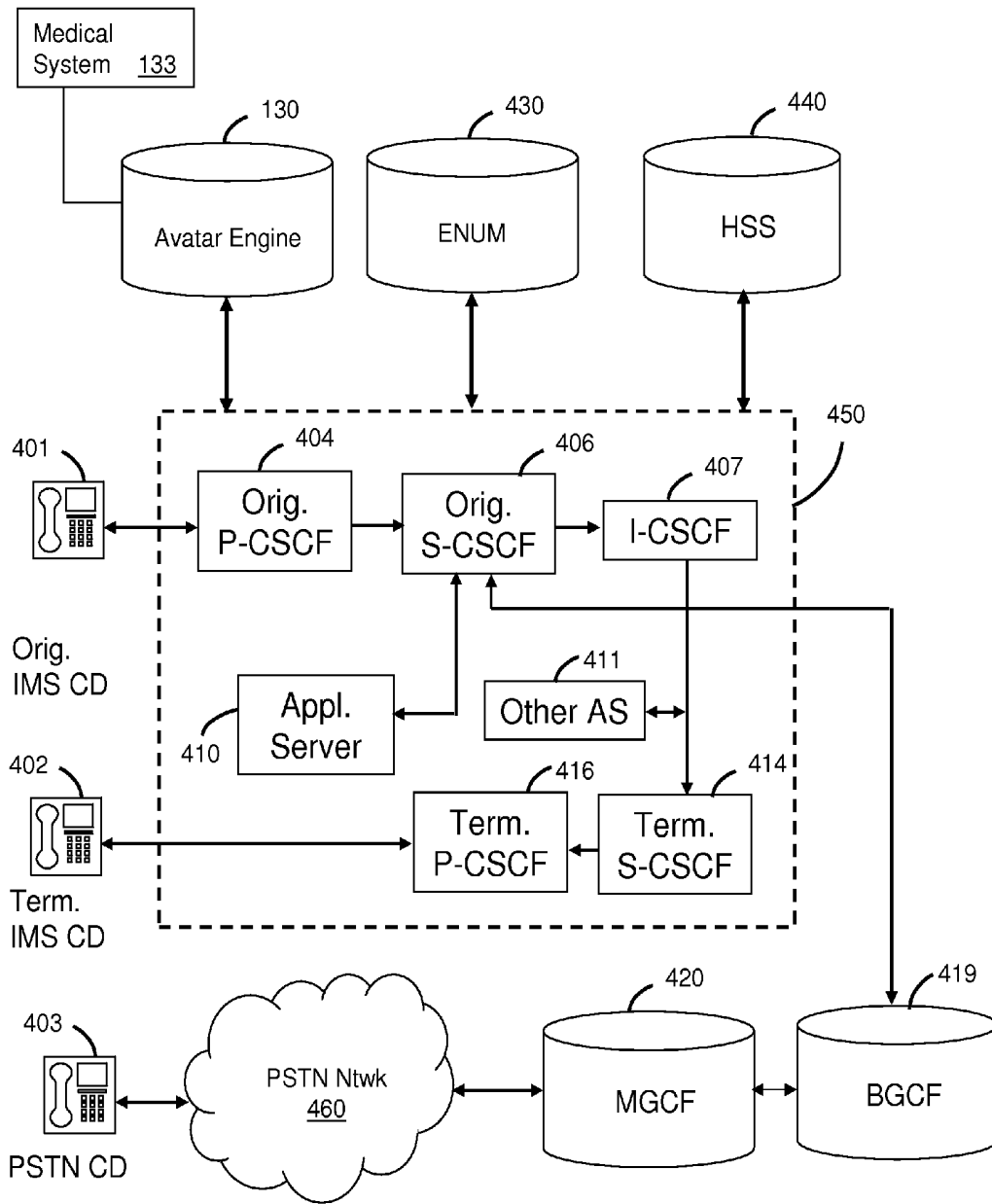

400
FIG. 4

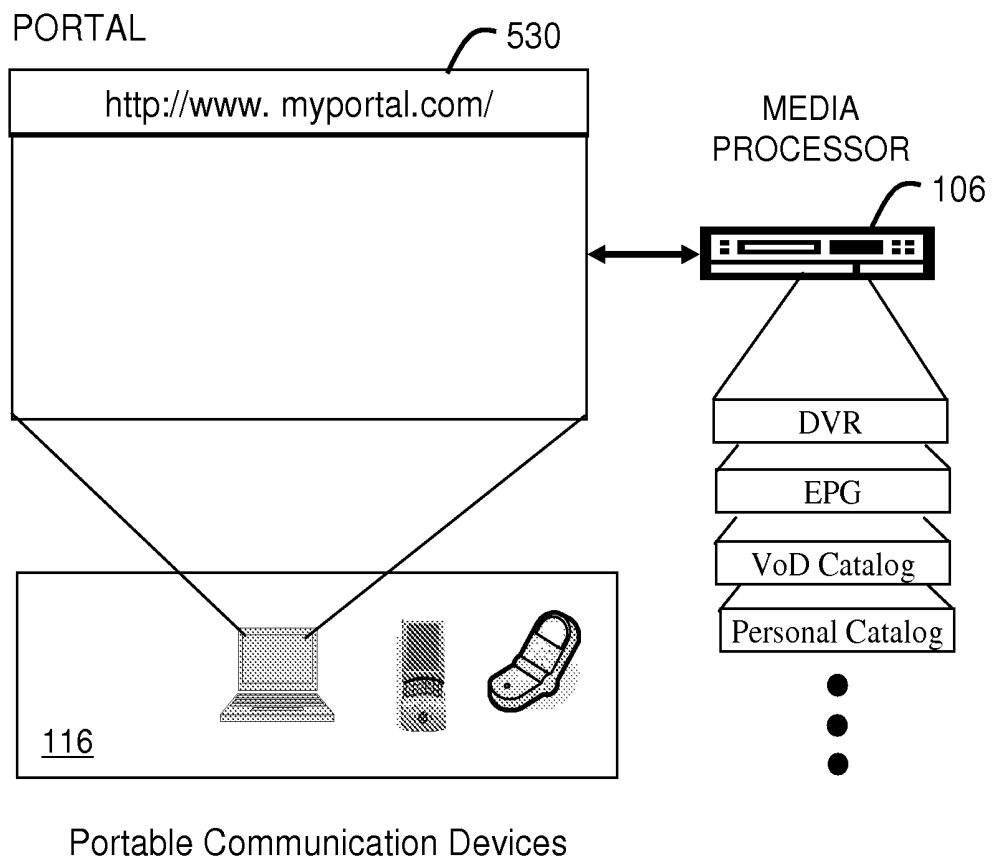

500

FIG. 5

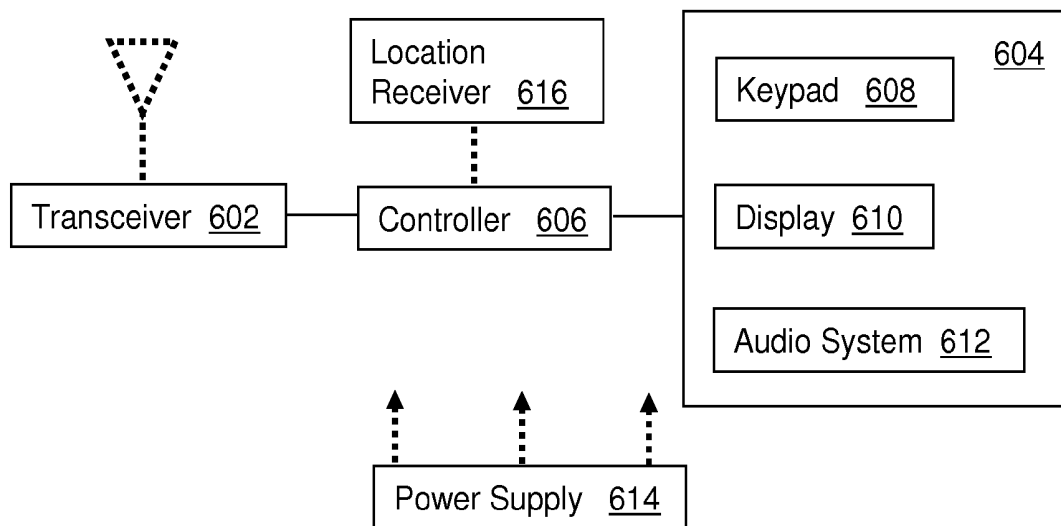

600
FIG. 6

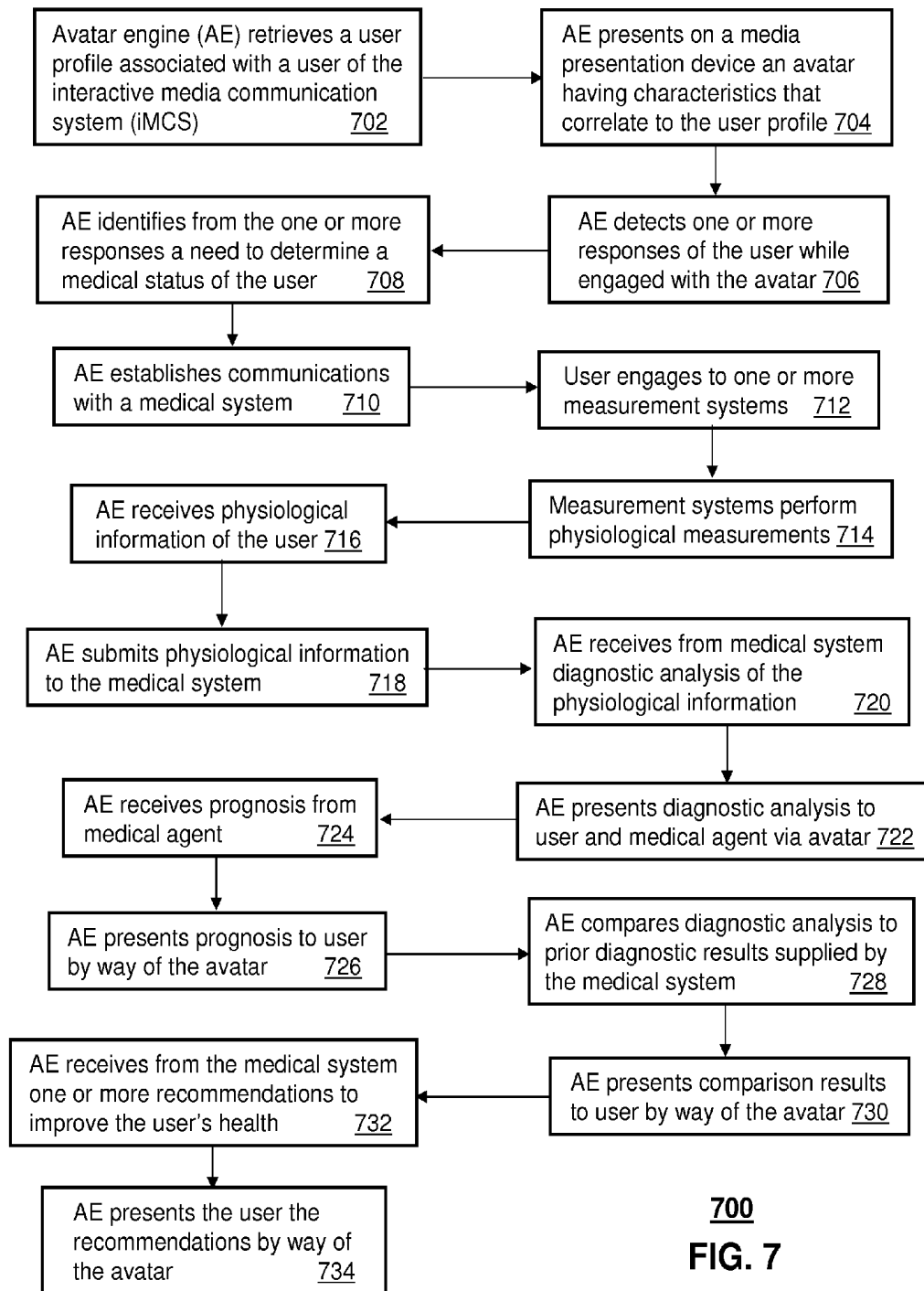

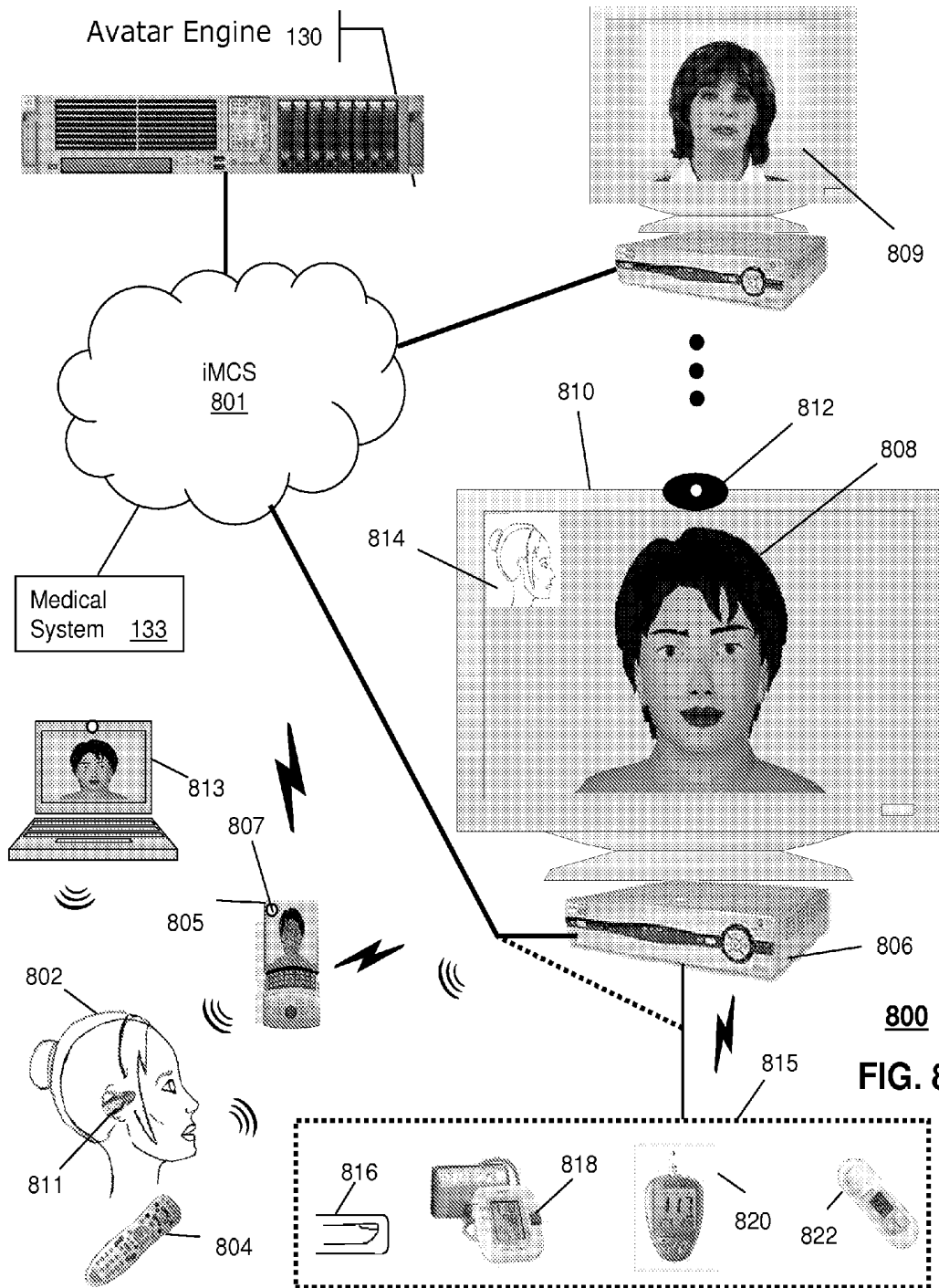

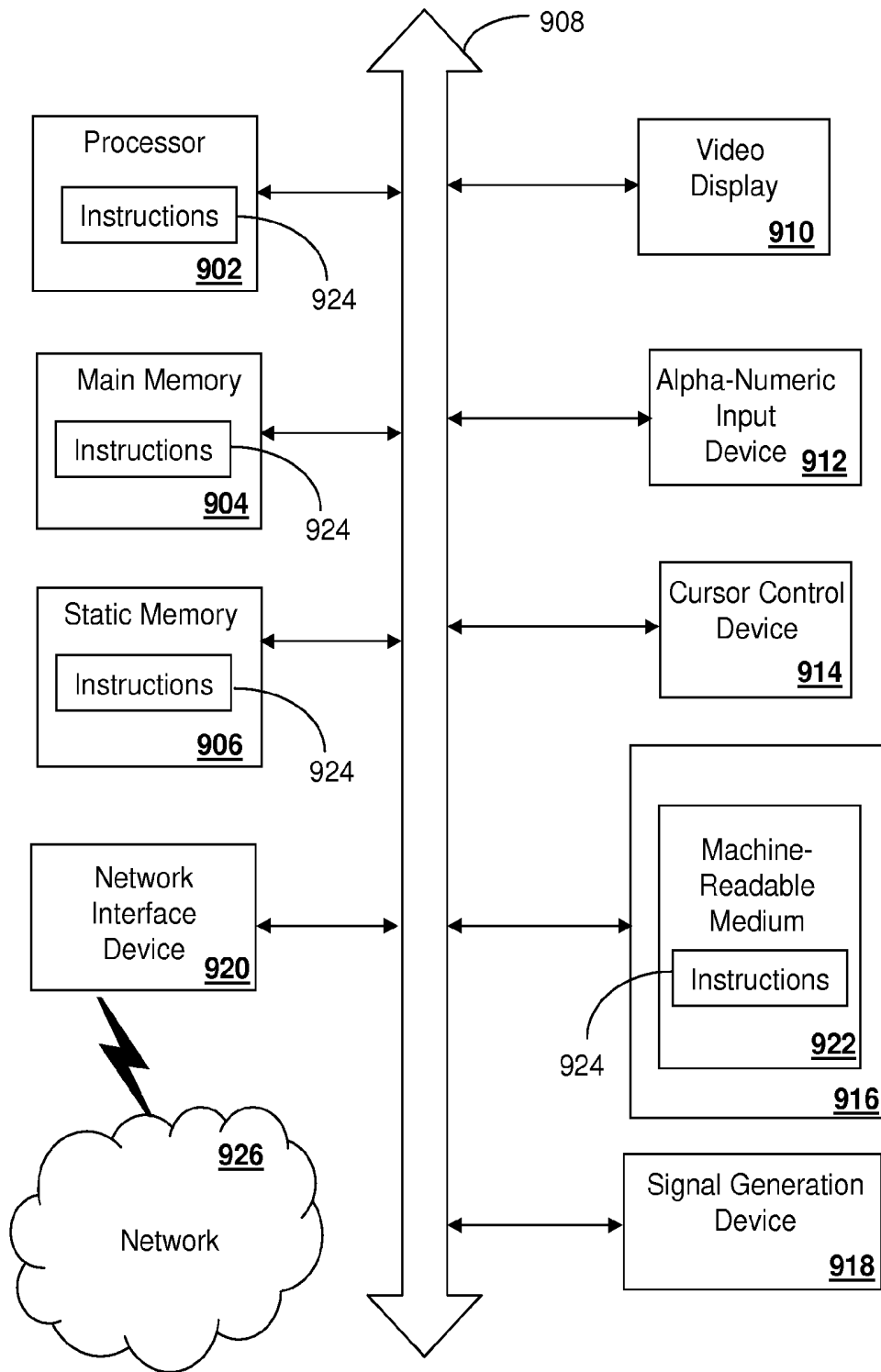

FIG. 9 900

SYSTEM AND METHOD FOR PERFORMING A DIAGNOSTIC ANALYSIS OF PHYSIOLOGICAL INFORMATION

FIELD OF THE DISCLOSURE

The present disclosure relates generally to diagnostic techniques and more specifically to a system and method for performing a diagnostic analysis of physiological information.

BACKGROUND

It is common place for individuals to schedule an appointment with a doctor to request a general checkup or to diagnose an ailment. A physician can perform diagnostics analysis of physiological information of a patient such as blood pressure, temperature, or a blood sample to determine the health of the patient and to diagnose ailments.

Machines such as blood pressure sensors, temperature sensors, heart rate sensors, glucose sensors, and so on, can be used outside of a doctor's office. Some individuals can share measurements from these machines with an on-line system as an alternative means of self diagnoses.

BRIEF DESCRIPTION OF THE DRAWINGS

FIGS. 1-4 depict illustrative embodiments of communication systems that provide media services;

FIG. 5 depicts an illustrative embodiment of a portal interacting with at least one among the communication systems of FIGS. 1-4;

FIG. 6 depicts an illustrative embodiment of a communication device utilized in the communication systems of FIGS. 1-4;

FIG. 7 depicts an illustrative embodiment of a method operating in portions of the communication systems of FIGS. 1-4;

FIG. 8 depicts an illustrative embodiment of a system operating according to the method of FIG. 7; and

FIG. 9 is a diagrammatic representation of a machine in the form of a computer system within which a set of instructions, when executed, may cause the machine to perform any one or more of the methodologies discussed herein.

DETAILED DESCRIPTION

One embodiment of the present disclosure can entail an avatar engine having a controller to retrieve a user profile of a user, present the user an avatar having characteristics that correlate to the user profile, detect one or more responses of the user during a communication exchange between the user and the avatar, identify from the one or more responses a need to determine a medical status of the user, establish communications with a medical diagnostic system, receive physiological information associated with the user, submit the physiological information to the medical diagnostic system, receive from the medical diagnostic system a diagnostic analysis of the physiological information, and present the diagnostic analysis to at least one of the user and a medical agent of the user, wherein the user is presented the diagnostic analysis by way of the avatar.

Another embodiment of the present disclosure can entail presenting a user an avatar having characteristics that correlate to a profile of the user, identifying from a communication exchange between the user and the avatar a need to physiologically analyze the user, receiving physiological informa-

tion associated with the user, submitting the physiological information to a medical system, receiving from the medical system a diagnostic analysis of the physiological information, and presenting the diagnostic analysis by way of the avatar.

Yet another embodiment of the present disclosure can entail a computer-readable storage medium having computer instructions for conducting a communication exchange between a user and an avatar, submitting to a medical system physiological information associated with the user, receiving from the medical system a diagnostic analysis of the physiological information, and presenting the diagnostic analysis by way of the avatar.

Another embodiment of the present disclosure can deliver an interactive avatar service that performs physiological diagnostic services.

Yet another embodiment of the present disclosure can entail a system having a controller to provide diagnostic analysis of physiological information supplied by an interactive avatar system.

FIG. 1 depicts an illustrative embodiment of a first communication system 100 for delivering media content. The communication system 100 can represent an Internet Protocol Television (IPTV) broadcast media system. In a typical IPTV infrastructure, there is a super head-end office (SHO) with at least one super headend office server (SHS) which receives national media programs from satellite and/or media servers from service providers of multimedia broadcast channels. In the present context, media programs can represent audio content, moving image content such as videos, still image content, and/or combinations thereof. The SHS server forwards IP packets associated with the media content to video head-end servers (VHS) via a network of aggregation points such as video head-end offices (VHO) according to a common multicast communication method.

The VHS then distributes multimedia broadcast programs via an access network to commercial and/or residential buildings 102 housing a gateway 104 (such as a residential gateway or RG). The access network can represent a bank of digital subscriber line access multiplexers (DSLAMs) located in a central office or a service area interface that provide broadband services over optical links or copper twisted pairs to buildings 102. The gateway 104 distributes broadcast signals to media processors 106 such as Set-Top Boxes (STBs) which in turn present broadcast selections to media devices 108 such as computers or television sets managed in some instances by a media controller 107 (such as an infrared or RF remote control). Unicast traffic can also be exchanged between the media processors 106 and subsystems of the IPTV media system for services such as video-on-demand (VoD). It will be appreciated by one of ordinary skill in the art that the media devices 108 and/or portable communication devices 116 shown in FIG. 1 can be an integral part of the media processor 106 and can be communicatively coupled to the gateway 104. In this particular embodiment, an integral device such as described can receive, respond, process and present multicast or unicast media content.

The IPTV media system can be coupled to one or more computing devices 130 a portion of which can operate as a web server for providing portal services over an Internet Service Provider (ISP) network 132 to fixed line media devices 108 or portable communication devices 116 by way of a wireless access point 117 providing Wireless Fidelity or WiFi services, or cellular communication services (such as GSM, CDMA, UMTS, WiMAX, etc.).

Another distinct portion of the one or more computing devices 130 can be used as an avatar engine (herein referred to

as avatar engine 130) for generating and managing interactive avatars which users of the first communication system 100 can be presented for general assistance and presentation of interactive television (iTV) services as well as other services such as described below in FIG. 7. The avatar engine 130 can use common imaging technology for creating avatars with human-like or animated qualities. The avatar engine 130 can also use common speech recognition and speech synthesis technology to produce an interactive avatar. With these technologies, the avatar engine 130 can determine the user's needs from a communication exchange between the user and the avatar image produced by the avatar engine.

The avatar engine 130 can be coupled by way of the ISP network 132 to a medical system 133 that employs common communication and computing technologies. The medical system 133 can have a database of diagnostic information which can be accessed by an artificial intelligence system operating in the medical system to analyze physiological information such as blood pressure, heart rate, glucose levels, weight, body fat, and so on, supplied by a user of the avatar by way of the avatar engine 130. The artificial intelligence algorithms operating in the medical system 133 can emulate common diagnostic analysis techniques employed by physicians to detect patient ailments and to provide mitigation recommendations in some instances with a prognosis. The medical system 133 can also provide recommendations to improve the avatar user's health.

A satellite broadcast television system can be used in place of the IPTV media system. In this embodiment, signals transmitted by a satellite 115 can be intercepted by a satellite dish receiver 131 coupled to building 102 which conveys media signals to the media processors 106. The media receivers 106 can be equipped with a broadband port to the ISP network 132. Although not shown, the communication system 100 can also be combined or replaced with analog or digital broadcast distributions systems such as cable TV systems.

FIG. 2 depicts an illustrative embodiment of a second communication system 200 for delivering media content. Communication system 200 can be overlaid or operably coupled with communication system 100 as another representative embodiment of said communication system. The system 200 includes a distribution switch/router system 228 at a central office 218. The distribution switch/router system 228 receives video data via a multicast television stream 230 from a second distribution switch/router 234 at an intermediate office 220. The multicast television stream 230 includes Internet Protocol (IP) data packets addressed to a multicast IP address associated with a television channel. The distribution switch/router system 228 can cache data associated with each television channel received from the intermediate office 220.

The distribution switch/router system 228 also receives unicast data traffic from the intermediate office 220 via a unicast traffic stream 232. The unicast traffic stream 232 includes data packets related to devices located at a particular residence, such as the residence 202. For example, the unicast traffic stream 232 can include data traffic related to a digital subscriber line, a telephone line, another data connection, or any combination thereof. To illustrate, the unicast traffic stream 232 can communicate data packets to and from a telephone 212 associated with a subscriber at the residence 202. The telephone 212 can be a Voice over Internet Protocol (VoIP) telephone. To further illustrate, the unicast traffic stream 232 can communicate data packets to and from a personal computer 210 at the residence 202 via one or more data routers 208. In an additional illustration, the unicast traffic stream 232 can communicate data packets to and from a set-top box device, such as the set-top box devices 204, 206.

The unicast traffic stream 232 can communicate data packets to and from the devices located at the residence 202 via one or more residential gateways 214 associated with the residence 202.

The distribution switch/router system 228 can send data to one or more access switch/router systems 226. The access switch/router system 226 can include or be included within a service area interface 216. In a particular embodiment, the access switch/router system 226 can include a DSLAM. The access switch/router system 226 can receive data from the distribution switch/router system 228 via a broadcast television (BTV) stream 222 and a plurality of unicast subscriber traffic streams 224. The BTV stream 222 can be used to communicate video data packets associated with a multicast stream.

For example, the BTV stream 222 can include a multicast virtual local area network (VLAN) connection between the distribution switch/router system 228 and the access switch/router system 226. Each of the plurality of subscriber traffic streams 224 can be used to communicate subscriber specific data packets. For example, the first subscriber traffic stream can communicate data related to a first subscriber, and the nth subscriber traffic stream can communicate data related to an nth subscriber. Each subscriber to the system 200 can be associated with a respective subscriber traffic stream 224. The subscriber traffic stream 224 can include a subscriber VLAN connection between the distribution switch/router system 228 and the access switch/router system 226 that is associated with a particular set-top box device 204, 206, a particular residence 202, a particular residential gateway 214, another device associated with a subscriber, or any combination thereof.

In an illustrative embodiment, a set-top box device, such as the set-top box device 204, receives a channel change command from an input device, such as a remote control device. The channel change command can indicate selection of an IPTV channel. After receiving the channel change command, the set-top box device 204 generates channel selection data that indicates the selection of the IPTV channel. The set-top box device 204 can send the channel selection data to the access switch/router system 226 via the residential gateway 214. The channel selection data can include an Internet Group Management Protocol (IGMP) Join request. In an illustrative embodiment, the access switch/router system 226 can identify whether it is joined to a multicast group associated with the requested channel based on information in the IGMP Join request.

If the access switch/router system 226 is not joined to the multicast group associated with the requested channel, the access switch/router system 226 can generate a multicast stream request. The multicast stream request can be generated by modifying the received channel selection data. In an illustrative embodiment, the access switch/router system 226 can modify an IGMP Join request to produce a proxy IGMP Join request. The access switch/router system 226 can send the multicast stream request to the distribution switch/router system 228 via the BTV stream 222. In response to receiving the multicast stream request, the distribution switch/router system 228 can send a stream associated with the requested channel to the access switch/router system 226 via the BTV stream 222.

The avatar engine 130 of FIG. 1 can be operably coupled to the second communication system 200 for purposes similar to those described above.

FIG. 3 depicts an illustrative embodiment of a third communication system 300 for delivering media content. Communication system 300 can be overlaid or operably coupled

with communication systems 100-200 as another representative embodiment of said communication systems. As shown, the system 300 can include a client facing tier 302, an application tier 304, an acquisition tier 306, and an operations and management tier 308. Each tier 302, 304, 306, 308 is coupled to a private network 310, such as a network of common packet-switched routers and/or switches; to a public network 312, such as the Internet; or to both the private network 310 and the public network 312. For example, the client-facing tier 302 can be coupled to the private network 310. Further, the application tier 304 can be coupled to the private network 310 and to the public network 312. The acquisition tier 306 can also be coupled to the private network 310 and to the public network 312. Additionally, the operations and management tier 308 can be coupled to the public network 312.

As illustrated in FIG. 3, the various tiers 302, 304, 306, 308 communicate with each other via the private network 310 and the public network 312. For instance, the client-facing tier 302 can communicate with the application tier 304 and the acquisition tier 306 via the private network 310. The application tier 304 can communicate with the acquisition tier 306 via the private network 310. Further, the application tier 304 can communicate with the acquisition tier 306 and the operations and management tier 308 via the public network 312. Moreover, the acquisition tier 306 can communicate with the operations and management tier 308 via the public network 312. In a particular embodiment, elements of the application tier 304, including, but not limited to, a client gateway 350, can communicate directly with the client-facing tier 302.

The client-facing tier 302 can communicate with user equipment via an access network 366, such as an IPTV access network. In an illustrative embodiment, customer premises equipment (CPE) 314, 322 can be coupled to a local switch, router, or other device of the access network 366. The client-facing tier 302 can communicate with a first representative set-top box device 316 via the first CPE 314 and with a second representative set-top box device 324 via the second CPE 322. In a particular embodiment, the first representative set-top box device 316 and the first CPE 314 can be located at a first customer premise, and the second representative set-top box device 324 and the second CPE 322 can be located at a second customer premise.

In another particular embodiment, the first representative set-top box device 316 and the second representative set-top box device 324 can be located at a single customer premise, both coupled to one of the CPE 314, 322. The CPE 314, 322 can include routers, local area network devices, modems, such as digital subscriber line (DSL) modems, any other suitable devices for facilitating communication between a set-top box device and the access network 366, or any combination thereof.

In an illustrative embodiment, the client-facing tier 302 can be coupled to the CPE 314, 322 via fiber optic cables. In another illustrative embodiment, the CPE 314, 322 can include DSL modems that are coupled to one or more network nodes via twisted pairs, and the client-facing tier 302 can be coupled to the network nodes via fiber-optic cables. Each set-top box device 316, 324 can process data received via the access network 366, via a common IPTV software platform.

The first set-top box device 316 can be coupled to a first external display device, such as a first television monitor 318, and the second set-top box device 324 can be coupled to a second external display device, such as a second television monitor 326. Moreover, the first set-top box device 316 can communicate with a first remote control 320, and the second set-top box device 324 can communicate with a second remote control 328. The set-top box devices 316, 324 can

include IPTV set-top box devices; video gaming devices or consoles that are adapted to receive IPTV content; personal computers or other computing devices that are adapted to emulate set-top box device functionalities; any other device adapted to receive IPTV content and transmit data to an IPTV system via an access network; or any combination thereof.

In an illustrative, non-limiting embodiment, each set-top box device 316, 324 can receive data, video, or any combination thereof, from the client-facing tier 302 via the access network 366 and render or display the data, video, or any combination thereof, at the display device 318, 326 to which it is coupled. In an illustrative embodiment, the set-top box devices 316, 324 can include tuners that receive and decode television programming signals or packet streams for transmission to the display devices 318, 326. Further, the set-top box devices 316, 324 can each include a STB processor 370 and a STB memory device 372 that is accessible to the STB processor 370. In one embodiment, a computer program, such as the STB computer program 374, can be embedded within the STB memory device 372.

In an illustrative embodiment, the client-facing tier 302 can include a client-facing tier (CFT) switch 330 that manages communication between the client-facing tier 302 and the access network 366 and between the client-facing tier 302 and the private network 310. As illustrated, the CFT switch 330 is coupled to one or more distribution servers, such as Distribution-servers (D-servers) 332, that store, format, encode, replicate, or otherwise manipulate or prepare video content for communication from the client-facing tier 302 to the set-top box devices 316, 324. The CFT switch 330 can also be coupled to a terminal server 334 that provides terminal devices with a point of connection to the IPTV system 300 via the client-facing tier 302.

In a particular embodiment, the CFT switch 330 can be coupled to a VoD server 336 that stores or provides VoD content imported by the IPTV system 300. Further, the CFT switch 330 is coupled to one or more video servers 380 that receive video content and transmit the content to the set-top boxes 316, 324 via the access network 366. The client-facing tier 302 may include a CPE management server 382 that manages communications to and from the CPE 314 and the CPE 322. For example, the CPE management server 382 may collect performance data associated with the set-top box devices 316, 324 from the CPE 314 or the CPE 322 and forward the collected performance data to a server associated with the operations and management tier 308.

In an illustrative embodiment, the client-facing tier 302 can communicate with a large number of set-top boxes, such as the representative set-top boxes 316, 324, over a wide geographic area, such as a metropolitan area, a viewing area, a statewide area, a regional area, a nationwide area or any other suitable geographic area, market area, or subscriber or customer group that can be supported by networking the client-facing tier 302 to numerous set-top box devices. In a particular embodiment, the CFT switch 330, or any portion thereof, can include a multicast router or switch that communicates with multiple set-top box devices via a multicast-enabled network.

As illustrated in FIG. 3, the application tier 304 can communicate with both the private network 310 and the public network 312. The application tier 304 can include a first application tier (APP) switch 338 and a second APP switch 340. In a particular embodiment, the first APP switch 338 can be coupled to the second APP switch 340. The first APP switch 338 can be coupled to an application server 342 and to an OSS/BSS gateway 344. In a particular embodiment, the application server 342 can provide applications to the set-top

box devices **316, 324** via the access network **366**, which enable the set-top box devices **316, 324** to provide functions, such as interactive program guides, video gaming, display, messaging, processing of VoD material and other IPTV content, etc. In an illustrative embodiment, the application server **342** can provide location information to the set-top box devices **316, 324**. In a particular embodiment, the OSS/BSS gateway **344** includes operation systems and support (OSS) data, as well as billing systems and support (BSS) data. In one embodiment, the OSS/BSS gateway **344** can provide or restrict access to an OSS/BSS server **364** that stores operations and billing systems data.

The second APP switch **340** can be coupled to a domain controller **346** that provides Internet access, for example, to users at their computers **368** via the public network **312**. For example, the domain controller **346** can provide remote Internet access to IPTV account information, e-mail, personalized Internet services, or other online services via the public network **312**. In addition, the second APP switch **340** can be coupled to a subscriber and system store **348** that includes account information, such as account information that is associated with users who access the IPTV system **300** via the private network **310** or the public network **312**. In an illustrative embodiment, the subscriber and system store **348** can store subscriber or customer data and create subscriber or customer profiles that are associated with IP addresses, stock-keeping unit (SKU) numbers, other identifiers, or any combination thereof, of corresponding set-top box devices **316, 324**. In another illustrative embodiment, the subscriber and system store can store data associated with capabilities of set-top box devices associated with particular customers.

In a particular embodiment, the application tier **304** can include a client gateway **350** that communicates data directly to the client-facing tier **302**. In this embodiment, the client gateway **350** can be coupled directly to the CFT switch **330**. The client gateway **350** can provide user access to the private network **310** and the tiers coupled thereto. In an illustrative embodiment, the set-top box devices **316, 324** can access the IPTV system **300** via the access network **366**, using information received from the client gateway **350**. User devices can access the client gateway **350** via the access network **366**, and the client gateway **350** can allow such devices to access the private network **310** once the devices are authenticated or verified. Similarly, the client gateway **350** can prevent unauthorized devices, such as hacker computers or stolen set-top box devices from accessing the private network **310**, by denying access to these devices beyond the access network **366**.

For example, when the first representative set-top box device **316** accesses the client-facing tier **302** via the access network **366**, the client gateway **350** can verify subscriber information by communicating with the subscriber and system store **348** via the private network **310**. Further, the client gateway **350** can verify billing information and status by communicating with the OSS/BSS gateway **344** via the private network **310**. In one embodiment, the OSS/BSS gateway **344** can transmit a query via the public network **312** to the OSS/BSS server **364**. After the client gateway **350** confirms subscriber and/or billing information, the client gateway **350** can allow the set-top box device **316** to access IPTV content and VoD content at the client-facing tier **302**. If the client gateway **350** cannot verify subscriber information for the set-top box device **316**, because it is connected to an unauthorized twisted pair, the client gateway **350** can block transmissions to and from the set-top box device **316** beyond the access network **366**.

As indicated in FIG. 3, the acquisition tier **306** includes an acquisition tier (AQT) switch **352** that communicates with the

private network **310**. The AQT switch **352** can also communicate with the operations and management tier **308** via the public network **312**. In a particular embodiment, the AQT switch **352** can be coupled to one or more live Acquisition-servers (A-servers) **354** that receive or acquire television content, movie content, advertisement content, other video content, or any combination thereof, from a broadcast service **356**, such as a satellite acquisition system or satellite head-end office. In a particular embodiment, the live acquisition server **354** can transmit content to the AQT switch **352**, and the AQT switch **352** can transmit the content to the CFT switch **330** via the private network **310**.

In an illustrative embodiment, content can be transmitted to the D-servers **332**, where it can be encoded, formatted, stored, replicated, or otherwise manipulated and prepared for communication from the video server(s) **380** to the set-top box devices **316, 324**. The CFT switch **330** can receive content from the video server(s) **380** and communicate the content to the CPE **314, 322** via the access network **366**. The set-top box devices **316, 324** can receive the content via the CPE **314, 322**, and can transmit the content to the television monitors **318, 326**. In an illustrative embodiment, video or audio portions of the content can be streamed to the set-top box devices **316, 324**.

Further, the AQT switch **352** can be coupled to a video-on-demand importer server **358** that receives and stores television or movie content received at the acquisition tier **306** and communicates the stored content to the VoD server **336** at the client-facing tier **302** via the private network **310**. Additionally, at the acquisition tier **306**, the VoD importer server **358** can receive content from one or more VoD sources outside the IPTV system **300**, such as movie studios and programmers of non-live content. The VoD importer server **358** can transmit the VoD content to the AQT switch **352**, and the AQT switch **352**, in turn, can communicate the material to the CFT switch **330** via the private network **310**. The VoD content can be stored at one or more servers, such as the VoD server **336**.

When users issue requests for VoD content via the set-top box devices **316, 324**, the requests can be transmitted over the access network **366** to the VoD server **336**, via the CFT switch **330**. Upon receiving such requests, the VoD server **336** can retrieve the requested VoD content and transmit the content to the set-top box devices **316, 324** across the access network **366**, via the CFT switch **330**. The set-top box devices **316, 324** can transmit the VoD content to the television monitors **318, 326**. In an illustrative embodiment, video or audio portions of VoD content can be streamed to the set-top box devices **316, 324**.

FIG. 3 further illustrates that the operations and management tier **308** can include an operations and management tier (OMT) switch **360** that conducts communication between the operations and management tier **308** and the public network **312**. In the embodiment illustrated by FIG. 3, the OMT switch **360** is coupled to a TV2 server **362**. Additionally, the OMT switch **360** can be coupled to an OSS/BSS server **364** and to a simple network management protocol monitor **386** that monitors network devices within or coupled to the IPTV system **300**. In a particular embodiment, the OMT switch **360** can communicate with the AQT switch **352** via the public network **312**.

The OSS/BSS server **364** may include a cluster of servers, such as one or more CPE data collection servers that are adapted to request and store operations systems data, such as performance data from the set-top box devices **316, 324**. In an illustrative embodiment, the CPE data collection servers may be adapted to analyze performance data to identify a condition of a physical component of a network path associated

with a set-top box device, to predict a condition of a physical component of a network path associated with a set-top box device, or any combination thereof.

In an illustrative embodiment, the live acquisition server **354** can transmit content to the AQT switch **352**, and the AQT switch **352**, in turn, can transmit the content to the OMT switch **360** via the public network **312**. In this embodiment, the OMT switch **360** can transmit the content to the TV2 server **362** for display to users accessing the user interface at the TV2 server **362**. For example, a user can access the TV2 server **362** using a personal computer **368** coupled to the public network **312**.

The avatar engine **130** of FIG. 1 can be operably coupled to the third communication system **300** for purposes similar to those described above.

It should be apparent to one of ordinary skill in the art from the foregoing media communication system embodiments that other suitable media communication systems for distributing broadcast media content as well as peer-to-peer exchange of content can be applied to the present disclosure.

FIG. 4 depicts an illustrative embodiment of a communication system **400** employing an IP Multimedia Subsystem (IMS) network architecture. Communication system **400** can be overlaid or operably coupled with communication systems **100-300** as another representative embodiment of said communication systems.

The communication system **400** can comprise a Home Subscriber Server (HSS) **440**, a tElephone NUmber Mapping (ENUM) server **430**, and network elements of an IMS network **450**. The IMS network **450** can be coupled to IMS compliant communication devices (CD) **401**, **402** or a Public Switched Telephone Network (PSTN) CD **403** using a Media Gateway Control Function (MGCF) **420** that connects the call through a common PSTN network **460**.

IMS CDs **401**, **402** register with the IMS network **450** by contacting a Proxy Call Session Control Function (P-CSCF) which communicates with a corresponding Serving CSCF (S-CSCF) to register the CDs with an Authentication, Authorization and Accounting (AAA) supported by the HSS **440**. To accomplish a communication session between CDs, an originating IMS CD **401** can submit a Session Initiation Protocol (SIP INVITE) message to an originating P-CSCF **404** which communicates with a corresponding originating S-CSCF **406**. The originating S-CSCF **406** can submit the SIP INVITE message to an application server (AS) such as reference **410** that can provide a variety of services to IMS subscribers. For example, the application server **410** can be used to perform originating treatment functions on the calling party number received by the originating S-CSCF **406** in the SIP INVITE message.

Originating treatment functions can include determining whether the calling party number has international calling services, and/or is requesting special telephony features (such as *72 forward calls, *73 cancel call forwarding, *67 for caller ID blocking, and so on). Additionally, the originating S-CSCF **406** can submit queries to the ENUM system **430** to translate an E.164 telephone number to a SIP Uniform Resource Identifier (URI) if the targeted communication device is IMS compliant. If the targeted communication device is a PSTN device, the ENUM system **430** will respond with an unsuccessful address resolution and the S-CSCF **406** will forward the call to the MGCF **420** via a Breakout Gateway Control Function (BGCF) **419**.

When the ENUM server **430** returns a SIP URI, the SIP URI is used by an Interrogating CSCF (I-CSCF) **407** to submit a query to the HSS **440** to identify a terminating S-CSCF **414** associated with a terminating IMS CD such as reference

402. Once identified, the I-CSCF **407** can submit the SIP INVITE to the terminating S-CSCF **414** which can call on an application server **411** similar to reference **410** to perform the originating treatment telephony functions described earlier. The terminating S-CSCF **414** can then identify a terminating P-CSCF **416** associated with the terminating CD **402**. The P-CSCF **416** then signals the CD **402** to establish communications. The aforementioned process is symmetrical. Accordingly, the terms "originating" and "terminating" in FIG. 4 can be interchanged.

IMS network **450** can also be operably coupled to the avatar engine **130** previously discussed for FIG. 1. In this representative embodiment, the avatar engine **130** can be accessed over a PSTN or VoIP channel of communication system **400** by common techniques such as described above.

FIG. 5 depicts an illustrative embodiment of a portal **530**. The portal **530** can be used for managing services of communication systems **100-400**. The portal **530** can be accessed by a Uniform Resource Locator (URL) with a common Internet browser such as Microsoft's Internet Explorer using an Internet-capable communication device such as references **108**, **116**, or **210** of FIGS. 1-2. The portal **530** can be configured to access a media processor such as references **106**, **204**, **206**, **316**, and **324** of FIGS. 1-3 and services managed thereby such as a Digital Video Recorder (DVR), an Electronic Programming Guide (EPG), VoD catalog, a personal catalog (such as personal videos, pictures, audio recordings, etc.) stored in the STB, a personal computer or server in a user's home or office, and so on.

FIG. 6 depicts an exemplary embodiment of a communication device **600**. Communication device **600** can be a representative portion of any of the aforementioned communication devices of FIGS. 1-4. The communication device **604** can comprise a wireline and/or wireless transceiver **602** (herein transceiver **602**), a user interface (UI) **604**, a power supply **614**, and a controller **606** for managing operations thereof. The transceiver **602** can support short-range or long-range wireless access technologies such as a Bluetooth wireless access protocol, a Wireless Fidelity (WiFi) access protocol, a Digital Enhanced Cordless Telecommunications (DECT) wireless access protocol, cellular, software defined radio (SDR) and/or WiMAX technologies, just to mention a few. Cellular technologies can include, for example, CDMA-1X, UMTS/HSDPA, GSM/GPRS, TDMA/EDGE, EV/DO, and next generation technologies as they arise.

The transceiver **602** can also support common wireline access technologies such as circuit-switched wireline access technologies, packet-switched wireline access technologies, or combinations thereof. PSTN can represent one of the common circuit-switched wireline access technologies. Voice over Internet Protocol (VoIP), and IP data communications can represent some of the commonly available packet-switched wireline access technologies. The transceiver **602** can also be adapted to support IP Multimedia Subsystem (IMS) protocol for interfacing to an IMS network that can combine PSTN and VoIP communication technologies.

The UI **604** can include a depressible or touch-sensitive keypad **608** and a navigation mechanism such as a roller ball, joystick, mouse, and/or navigation disk for manipulating operations of the communication device **600**. The keypad **608** can be an integral part of a housing assembly of the communication device **600** or an independent device operably coupled thereto by a tethered wiring interface (such as a USB) or a wireless interface supporting for example Bluetooth. The keypad **608** can represent a numeric dialing keypad commonly used by phones, and/or a Qwerty keypad with alphanumeric keys.

The UI **604** can further include a display **610** such as monochrome or color LCD (Liquid Crystal Display), OLED (Organic Light Emitting Diode) or other suitable display technology for conveying images to the end user of the communication device **600**. In an embodiment where the display **610** is touch-sensitive, a portion or all of the keypad **608** can be presented by way of the display. The UI **604** can also include an audio system **612** that utilizes common audio technology for conveying low volume audio (such as audio heard only in the proximity of a human ear) and high volume audio (such as speakerphone for hands free operation). The audio system **612** can further include a microphone for receiving audible signals of an end user.

The power supply **614** can utilize common power management technologies such as replaceable and rechargeable batteries, supply regulation technologies, and charging system technologies for supplying energy to the components of the communication device **600** to facilitate long-range or short-range portable applications. The controller **606** can utilize computing technologies such as a microprocessor and/or digital signal processor (DSP) with associated storage memory such as Flash, ROM, RAM, SRAM, DRAM or other storage technologies.

FIG. **7** depicts an illustrative method **700** operating in portions of communication systems **100-400**. FIG. **8** depicts an illustrative embodiment of a system **800** operating according to the method of FIG. **7**. FIG. **8** depicts an interactive media communication system **801** such as the systems shown in FIGS. **1-4** (singly or collectively). The interactive media communication system (iMCS) can be coupled to the avatar engine **130** and one or more STBs **806**. The STBs **806** can be operatively coupled to media presentation devices such as a high-definition television (HDTV) **810** which can present avatar images **808** (herein referred to as avatar **808**) supplied by the avatar engine **130** by way of the STBs. A user **802** of the STB **806** can interact with the avatar **808** by speech as well as tactile controls using a remote control **804**.

The HDTV **812** can also have a common camera sensor **812** for capturing still and/or moving images of the user **802**, which can be displayed in part by the HDTV as a picture-in-picture (PIP) image **814**. The visual images of the user can be conveyed to the STB **806**. Speech can be detected by a microphone of an audio system of the remote control **804** or an audio system of the STB **806**. The avatar **808** can be an animated image, or can have human-like qualities such as the avatar image **809**. The STB **806** can transmit to the avatar engine **130** the visual images as well as speech signals of the user **802** for analysis.

The avatar engine **130** can also be communicatively coupled to a mobile phone **805** with a camera **807** that can convey still or moving images of the user **802** to the avatar engine. The mobile phone **805** can have an audio system for receiving responses of the user **802** and for conveying the user's speech to the avatar engine **130**. The audio system can also have a loud speaker to convey to the user **802** synthesized speech of the avatar **808** for hands-free operations. To avoid disturbing others, the mobile phone **805** can also incorporate common Bluetooth wireless transceiver technology to communicate with a common Bluetooth headset **811** worn by the user **802**. Similarly, the avatar engine **130** can be communicatively coupled to a computer **813** with similar resources as the mobile phone **805**.

The avatar engine **130** can further be communicatively coupled directly or indirectly by way of the STB **806** to physiological measurement equipment **815**. The measurement equipment **815** can include a standard interface such as a USB port that enables these devices to be tethered to the

STB **806** for conveying measurements to the avatar engine **130**. Alternatively, these devices can be wirelessly coupled to the STB **806** with technologies such as Bluetooth or WiFi.

FIG. **8** depicts illustrations of the possible types of measurement equipment **815** that can be used by the user **802** to convey physiological information to the medical system **133** by way of the avatar engine **130**. The user **802** can for example utilize a pulse oximeter sensor **816** to measure the user's pulse and oxygen saturation in the user's blood. The user **802** can also utilize a blood pressure meter **818**, a glucose meter **820**, a thermometer **822**, as well as other common physiological measurement devices (not shown) to convey physiological data to the avatar engine **130**. The avatar engine **130** can establish communications with the medical system **133** described in FIG. **1** by way of the iMCS **801**.

With system **800** in mind, method **700** can begin with step **702** in which the avatar engine **130** retrieves a user profile associated with the user **802** of the iMCS **801**. This step can be responsive to the user **802** requesting access to the avatar **808** by initiating a speech command or tactile command (such as selecting an avatar request button on the remote control **804**) that is detected by the STB **806**, and thereby conveyed to the avatar engine **130**. The user profile can include demographic profiling information of the user **802**, psychographic profiling information of the user, and/or user preferences supplied by the user. The demographic profiling information of the user **802** can be based on age, gender, income, number of occupants in household, occupation, education, value of residential property, location of residential property, and/or fees paid for services rendered by the iMCS **801**—just to name a few possibilities.

The demographic profiling information of the user **802** can be determined from a subscriber account of the user and/or monitored media consumption behavior of the user. One or more network elements of the iMCS **801** can utilize common demographic analysis tools to make these determinations. The psychographic profiling information of the user **802** can also be determined from monitored media consumption behavior of the user and/or subscriber account information. Utilizing common psychographic analysis tools, one or more network elements of the iMCS **801** can generate the psychographic profiling information of the user **802**. The psychographic profiling information can identify one or more traits, attitudes, interests, and/or lifestyles of the user **802**.

User preferences supplied by the user **802** can identify, for example, a preferred gender for the avatar, a preferred image (could be an image of the user **802**, an image of a friend or spouse of the user, celebrity, etc.), a preferred personality for the avatar (mild-mannered avatar), preferred search preferences, preferred content sources, preferred merchants for purchasing or selling goods or services, medical profile of the user, and so on.

In step **704** the avatar engine **130** can present on the HDTV **810** the avatar **808** correlated to the user profile as described above. The avatar engine **130** can use common correlation technology to statistically generate an avatar image that is likely suited for the user **802** according to the aforementioned aspects provided by the user profile. Using common speech synthesis and recognition technology, the avatar engine **130** can interact with the user **802** by way of the avatar **808** to provide interactive media services. The interactive function can be initiated by the user **802** with speech or tactile responses on the remote control **804** which can be detected by the avatar engine **130** in step **706** by way of the STB **806**.

User responses can represent any detectable visual or audible response of the user **802** determined from an exchange between the user and the avatar engine **130** by way

of the avatar **808**. A response for example can represent a command such as, “Show me my weight charts”, “Record my blood pressure”, “Show me my cholesterol data overlaid by my exercise regimen”, “Show me my next doctor’s appointment”, “Show my potential side effects of taking statins”, and so on.

The avatar engine **130** can also be programmed, for example, to identify in step **708** from the user’s responses a need to determine a medical status of the user. Suppose the user **802** tells the avatar **808** s/he is not feeling well. In step **708** the avatar **808** can ask the user **802** what s/he is feeling, and recommend that the user engage with one or more of the measurement devices **815** available to the user. The avatar engine **130** can establish communications with the medical system **133** in preparation to analyze physiological data supplied by the user **802** by way of the measurement devices **815**. Based on the ailment description given by the user **802** and known health conditions supplied in the medical profile of the user, the avatar engine **130** can request by way of the avatar **808** that the user **802** engage in step **712** with the pulse oximetry sensor **816**, the blood pressure sensor **818** and the thermometer **822**, and provide a blood sample to the glucose sensor **820**. As noted earlier, each of these devices can be coupled to the STB **806** by a tethered interface or a wireless interface such as WiFi or Bluetooth.

Once measurements are taken by these devices in step **714**, the results can be conveyed to the avatar engine **130** by way of the STB **806** (or by direct access to the avatar engine over the ISP network **132**). Upon receiving the physiological data in step **716**, the avatar engine **130** submits it to the medical system **133** for analysis in step **718**. As described earlier, the medical system **133** can employ artificial intelligence that can function in part as an expert system specialized in performing diagnostic analysis of physiological data. In step **714**, the medical system **133** can retrieve a physiological profile of the user (which can be similar or more comprehensive than the medical profile in the user preferences described earlier). The physiological profile can indicate, for example, that the user is 6 feet tall, weighs 200 lbs, has high blood pressure, and suffers from type 1 diabetes. This information can guide the medical system **133** in diagnosing the physiological data supplied by the avatar engine **130**.

For example, the medical system **133** can determine that the user’s blood pressure has risen higher than usual, while other physiological readings appear normal. Under these circumstances, the medical system **133** can provide the avatar engine **130** the diagnostic results in step **720**, which the avatar engine **130** can present to the user and a medical agent of the user (such as a physician or registered nurse). The user **802** and the medical agent can be presented in step **722** the diagnostic results by way of the avatar **808**. The medical agent can be contacted by the avatar engine **130** over the ISP network **132** to a computer terminal of the agent which presents the avatar **808**. The medical agent can in turn review the diagnostic analysis and provide the avatar engine **130** by way of an interaction with the avatar **808** a prognosis in step **724** subject to medication prescribed for the user **802** by the agent.

In step **726** the avatar engine **130** can inform the user **802** by way of the avatar **808** of the prescribed medication and the prognosis given by the medical agent. The avatar engine **130** can compare in step **728** the diagnostic analysis of step **720** to prior diagnostic results supplied by the medical system **130** to determine whether the user’s health condition has improved or deteriorated. The avatar engine **130** can present the user **802** the comparison results in step **730** by way of the avatar **808**. The medical system **133** can also provide the avatar engine **130** in step **732** one or more recommendations to

improve the user’s health. For example, the medical system **133** can recommend that the user avoid certain foods with high sodium levels which can exacerbate the user’s high blood pressure. The avatar engine **130** can present the user **802** these recommendations in step **734** by way of the avatar **808**.

Upon reviewing the aforementioned embodiments, it would be evident to an artisan with ordinary skill in the art that said embodiments can be modified, reduced, or enhanced without departing from the scope and spirit of the claims described below. For example, method **700** can be adapted so that the medical system **133** provides the prognosis after recommending over the counter non-prescription medication. The method **700** can also be adapted so that the user **802** can describe his/her ailment to the avatar **808** which medical system **133** can then diagnose according to the descriptions provided.

In another embodiment, the avatar engine **130** can be integrated in any communication device. For example, the avatar engine **130** can be an integral part of the STB **806**, a mobile phone, a PDA, a gaming console, a communication device of an IMS system such as shown in FIG. **4**, a portal, and so on. Additionally, the avatar engine **130** can be distributed between devices. Similarly, the medical system **133** can be integrated in the avatar engine **130** and/or operate as an independent application in the user’s computing or communication devices, which can be accessed by the avatar engine **130**. In these embodiments, the user **802** can perform the tasks of method **700** in a portable fashion at any location.

It should be apparent from these illustrations that other suitable modifications can be applied to the present disclosure without departing from the scope of the claims below. Accordingly, the reader is directed to the claims section for a fuller understanding of the breadth and scope of the present disclosure.

FIG. **9** depicts an exemplary diagrammatic representation of a machine in the form of a computer system **900** within which a set of instructions, when executed, may cause the machine to perform any one or more of the methodologies discussed above. In some embodiments, the machine operates as a standalone device. In some embodiments, the machine may be connected (e.g., using a network) to other machines. In a networked deployment, the machine may operate in the capacity of a server or a client user machine in server-client user network environment, or as a peer machine in a peer-to-peer (or distributed) network environment.

The machine may comprise a server computer, a client user computer, a personal computer (PC), a tablet PC, a laptop computer, a desktop computer, a control system, a network router, switch or bridge, or any machine capable of executing a set of instructions (sequential or otherwise) that specify actions to be taken by that machine. It will be understood that a device of the present disclosure includes broadly any electronic device that provides voice, video or data communication. Further, while a single machine is illustrated, the term “machine” shall also be taken to include any collection of machines that individually or jointly execute a set (or multiple sets) of instructions to perform any one or more of the methodologies discussed herein.

The computer system **900** may include a processor **902** (e.g., a central processing unit (CPU), a graphics processing unit (GPU, or both)), a main memory **904** and a static memory **906**, which communicate with each other via a bus **908**. The computer system **900** may further include a video display unit **910** (e.g., a liquid crystal display (LCD), a flat panel, a solid state display, or a cathode ray tube (CRT)). The computer system **900** may include an input device **912** (e.g., a key-

board), a cursor control device **914** (e.g., a mouse), a disk drive unit **916**, a signal generation device **918** (e.g., a speaker or remote control) and a network interface device **920**.

The disk drive unit **916** may include a machine-readable medium **922** on which is stored one or more sets of instructions (e.g., software **924**) embodying any one or more of the methodologies or functions described herein, including those methods illustrated above. The instructions **924** may also reside, completely or at least partially, within the main memory **904**, the static memory **906**, and/or within the processor **902** during execution thereof by the computer system **900**. The main memory **904** and the processor **902** also may constitute machine-readable media.

Dedicated hardware implementations including, but not limited to, application specific integrated circuits, programmable logic arrays and other hardware devices can likewise be constructed to implement the methods described herein. Applications that may include the apparatus and systems of various embodiments broadly include a variety of electronic and computer systems. Some embodiments implement functions in two or more specific interconnected hardware modules or devices with related control and data signals communicated between and through the modules, or as portions of an application-specific integrated circuit. Thus, the example system is applicable to software, firmware, and hardware implementations.

In accordance with various embodiments of the present disclosure, the methods described herein are intended for operation as software programs running on a computer processor. Furthermore, software implementations can include, but not limited to, distributed processing or component/object distributed processing, parallel processing, or virtual machine processing can also be constructed to implement the methods described herein.

The present disclosure contemplates a machine readable medium containing instructions **924**, or that which receives and executes instructions **924** from a propagated signal so that a device connected to a network environment **926** can send or receive voice, video or data, and to communicate over the network **926** using the instructions **924**. The instructions **924** may further be transmitted or received over a network **926** via the network interface device **920**.

While the machine-readable medium **922** is shown in an example embodiment to be a single medium, the term "machine-readable medium" should be taken to include a single medium or multiple media (e.g., a centralized or distributed database, and/or associated caches and servers) that store the one or more sets of instructions. The term "machine-readable medium" shall also be taken to include any medium that is capable of storing, encoding or carrying a set of instructions for execution by the machine and that cause the machine to perform any one or more of the methodologies of the present disclosure.

The term "machine-readable medium" shall accordingly be taken to include, but not be limited to: solid-state memories such as a memory card or other package that houses one or more read-only (non-volatile) memories, random access memories, or other re-writable (volatile) memories; magneto-optical or optical medium such as a disk or tape; and/or a digital file attachment to e-mail or other self-contained information archive or set of archives is considered a distribution medium equivalent to a tangible storage medium. Accordingly, the disclosure is considered to include any one or more of a machine-readable medium or a distribution medium, as listed herein and including art-recognized equivalents and successor media, in which the software implementations herein are stored.

Although the present specification describes components and functions implemented in the embodiments with reference to particular standards and protocols, the disclosure is not limited to such standards and protocols. Each of the standards for Internet and other packet switched network transmission (e.g., TCP/IP, UDP/IP, HTML, HTTP) represent examples of the state of the art. Such standards are periodically superseded by faster or more efficient equivalents having essentially the same functions. Accordingly, replacement standards and protocols having the same functions are considered equivalents.

The illustrations of embodiments described herein are intended to provide a general understanding of the structure of various embodiments, and they are not intended to serve as a complete description of all the elements and features of apparatus and systems that might make use of the structures described herein. Many other embodiments will be apparent to those of skill in the art upon reviewing the above description. Other embodiments may be utilized and derived therefrom, such that structural and logical substitutions and changes may be made without departing from the scope of this disclosure. Figures are also merely representational and may not be drawn to scale. Certain proportions thereof may be exaggerated, while others may be minimized. Accordingly, the specification and drawings are to be regarded in an illustrative rather than a restrictive sense.

Such embodiments of the inventive subject matter may be referred to herein, individually and/or collectively, by the term "invention" merely for convenience and without intending to voluntarily limit the scope of this application to any single invention or inventive concept if more than one is in fact disclosed. Thus, although specific embodiments have been illustrated and described herein, it should be appreciated that any arrangement calculated to achieve the same purpose may be substituted for the specific embodiments shown. This disclosure is intended to cover any and all adaptations or variations of various embodiments. Combinations of the above embodiments, and other embodiments not specifically described herein, will be apparent to those of skill in the art upon reviewing the above description.

The Abstract of the Disclosure is provided to comply with 37 C.F.R. §1.72(b), requiring an abstract that will allow the reader to quickly ascertain the nature of the technical disclosure. It is submitted with the understanding that it will not be used to interpret or limit the scope or meaning of the claims. In addition, in the foregoing Detailed Description, it can be seen that various features are grouped together in a single embodiment for the purpose of streamlining the disclosure. This method of disclosure is not to be interpreted as reflecting an intention that the claimed embodiments require more features than are expressly recited in each claim. Rather, as the following claims reflect, inventive subject matter lies in less than all features of a single disclosed embodiment. Thus the following claims are hereby incorporated into the Detailed Description, with each claim standing on its own as a separately claimed subject matter.

What is claimed is:

1. An avatar engine, comprising:

a memory that stores instructions; and

a processor coupled to the memory, wherein responsive to executing the instructions, the processor performs operations comprising:

retrieving a user profile of a user and an image of the user; generating an avatar based on the image of the user and based on statistical modeling that utilizes a demographic profile of the user and historical media consumption behavior of the user;

providing interactive media services to the user via a communication exchange between the user and the avatar, wherein the interactive media services include non-medical services;

presenting medical questions to the user;

receiving responses from the user in response to the presenting of the medical questions;

requesting, by way of the avatar being presented, that the user perform physiological tests to generate physiological information from the physiological tests based on the responses;

receiving the physiological information;

submitting the physiological information and the responses to a medical diagnostic system;

receiving from the medical diagnostic system a diagnostic analysis of the physiological information and the responses;

accessing prior diagnostic results supplied by a medical diagnostic system;

comparing the diagnostic analysis with the prior diagnostic results as a comparison;

determining a health condition of the user that indicates an improvement or deterioration in health based on the comparison;

presenting the diagnostic analysis to equipment of a medical agent of the user, wherein the medical agent is presented the diagnostic analysis by way of the avatar;

receiving from the equipment of the medical agent a prognosis and prescription determined from the diagnostic analysis; and

presenting the user with the health condition, the prognosis and the prescription by way of the avatar.

2. The avatar engine of claim **1**, wherein the physiological information comprises one of a body temperature measurement of the user, a blood pressure measurement of the user, a heart rate measurement of the user, a height measurement of the user, a weight measurement of the user, or a body fat measurement of the user.

3. The avatar engine of claim **1**, wherein the physiological information is obtained by one of a plurality of selected physiological measuring devices, and wherein the operations further comprise receiving the physiological information via wireless communication with the one of the plurality of physiological measuring devices.

4. The avatar engine of claim **1**, wherein the medical agent corresponds to one of a physician or a nurse, wherein the avatar is generated prior to receiving the physiological information, and wherein the avatar engine comprises a set top box providing interactive television services.

5. The avatar engine of claim **1**, wherein the operations further comprise presenting to the user by way of the avatar the improvement or deterioration in the health condition of the user.

6. The avatar engine of claim **5**, wherein the avatar engine operates in a computing device communicatively coupled to an interactive media communication system comprising an internet protocol television communication system and an internet protocol multimedia subsystem communication system.

7. The avatar engine of claim **1**, wherein the operations further comprise presenting a prognosis and presenting an identification of prescribed medication by way of the avatar.

8. A method, comprising:

generating an avatar utilizing an image of a user, wherein the avatar is generated by a computing device executing computer instructions for an avatar engine;

presenting, by the computing device, the avatar;

analyzing, by the computing device, a communication exchange between the user and the avatar to determine a potential physiological change of the user;

requesting, by the avatar being presented, that the user perform physiological tests to generate physiological information from the physiological tests based on the potential physiological change of the user;

receiving, by the computing device, the physiological information;

submitting, by the computing device, the physiological information and the communication exchange to a medical system;

receiving, by the computing device, from the medical system a diagnostic analysis of the physiological information and the communication exchange;

accessing, by the computing device, prior diagnostic results supplied by the medical system;

comparing, by the computing device, the diagnostic analysis with the prior diagnostic results;

determining, by the computing device, whether a health condition of the user has improved or deteriorated based on the comparing, wherein the computing device provides interactive television services;

presenting, by the computing device, the diagnostic analysis to equipment of a medical agent of the user, wherein the medical agent is presented the diagnostic analysis by way of the avatar;

receiving, by the computing device, from the equipment of the medical agent a prognosis and prescription determined from the diagnostic analysis; and

presenting, by the computing device, the user with the health condition, the prognosis and the prescription by way of the avatar.

9. The method of claim **8**, wherein the generation of the avatar is based in part on statistical modeling that utilizes a demographic profile of the user and historical media consumption behavior of the user, wherein the avatar is generated prior to receiving the physiological information.

10. The method of claim **9**, wherein the medical agent corresponds to one of a physician or a nurse.

11. The method of claim **8**, wherein the physiological information comprises one of a body temperature measurement of the user, a blood pressure measurement of the user, a heart rate measurement of the user, a height measurement of the user, a weight measurement of the user, or a body fat measurement of the user.

12. The method of claim **8**, wherein the medical system is adapted to retrieve a physiological profile of the user to perform the diagnostic analysis of the physiological information.

13. The method of claim **8**, wherein the computing device is communicatively coupled to an interactive media communication system for providing the interactive television services.

14. The method of claim **13**, wherein the interactive media communication system comprises an internet protocol television communication system and an internet protocol multimedia subsystem communication system.

15. A non-transitory, machine-readable computer-readable storage medium, comprising instructions, wherein respon

sive to executing the instructions, a processor performs operations comprising:

conducting a communication exchange between a user and an avatar presented by a set top box, wherein the set top box is associated with the processor, wherein the communication exchange is associated with interactive media services for the user, wherein the interactive media services include non-medical services, wherein the avatar is generated based on an image of the user and based on statistical modeling that utilizes a demographic profile of the user and historical media consumption behavior of the user;

selecting a physiological measuring device from a group of physiological measuring devices as a selected physiological measuring device, wherein a potential physiological change is identified based on the communication exchange, and wherein the selected physiological measuring device collects physiological information associated with the user based on the communication exchange;

receiving the physiological information from the selected physiological measuring device;

submitting to a medical system the physiological information associated with the user and the communication exchange, the medical system being selected in response to a determination of a change to a medical status of the user from an analysis of responses during the communication exchange;

receiving from the medical system a diagnostic analysis of the physiological information and the communication exchange;

accessing prior diagnostic results supplied by the medical system;

comparing the diagnostic analysis with the prior diagnostic results to generate a comparison; and

determining whether a health condition of the user has changed based on the comparison;

presenting the diagnostic analysis and a notification that the health condition has changed to equipment of a medical agent of the user, wherein the medical agent is presented the diagnostic analysis by way of the avatar;

receiving, from the equipment of the medical agent, one of a prognosis and prescription determined from the diagnostic analysis; and

presenting the user with the health condition, the prognosis and the prescription by way of the avatar.

16. The non-transitory, machine-readable storage medium of claim **15**, wherein the operations further comprise generating the avatar correlated to a profile of the user, wherein the interactive media services includes user calendar services.

17. The non-transitory, machine-readable storage medium of claim **15**, wherein the selected physiological measuring device comprises a plurality of selected physiological measuring devices from among the group of physiological measuring devices,

wherein the physiological information comprises one of a body temperature measurement of the user, a blood pressure measurement of the user, a heart rate measurement of the user, a height measurement of the user, a weight measurement of the user, a body fat measurement of the user, or any combination thereof.

18. The non-transitory, machine-readable storage medium of claim **15**, wherein the avatar is generated prior to receiving the physiological information of the user.

19. The non-transitory, machine-readable storage medium of claim **15**, wherein the operations further comprise:

receiving from the medical system recommendations for healthcare for the user; and

presenting to the user the recommendations by way of the avatar.

20. A method, comprising:

providing, by a set top box, interactive media services to a user via a communication exchange between the user and an avatar, wherein the interactive media services include non-medical services;

analyzing a communication exchange between the user and the avatar, wherein the analyzing is performed by the set top box to generate an analysis;

determining, by the set top box, a determined change to a medical status of the user based on the analysis of the communication exchange;

selecting, by the set top box, a physiological measuring device from a group of physiological measuring devices as a selected physiological measuring device, wherein the selected physiological measuring device collects physiological information associated with the user;

requesting, by the avatar being presented, that the user utilize the physiological measuring device to generate physiological information from a physiological test;

receiving, by the set top box, the physiological information from the physiological measuring device once the user completes the physiological test;

submitting, by the set top box, the physiological information and the determined change in medical status of the user over a network to a medical diagnostic system;

accessing, by the set top box, prior diagnostic results supplied by the medical diagnostic system;

comparing, by the set top box, a diagnostic analysis associated with the physiological information and the determined change in medical status of the user with the prior diagnostic results; and

determining, by the set top box, whether a health condition of the user has changed based on the comparing;

presenting a change of the health condition to equipment of a medical agent of the user, wherein the medical agent is presented the diagnostic analysis by way of the avatar;

receiving from the equipment of the medical agent a prescription determined from the change of the health condition; and

presenting the user with the health condition and the prescription by way of the avatar.

21. A system, comprising:

a memory to store instructions; and

a processor coupled to the memory, wherein responsive to executing the instructions, the processor performs operations comprising:

generating an avatar based on an image of a user and based on statistical modeling that utilizes a demographic profile of the user and historical media consumption behavior of the user;

analyzing a communication exchange between the user and the avatar;

determining a change to a medical status of the user based on the analyzing of the communication exchange;

requesting that the user implement a physiological measuring device from a group of physiological measuring devices based on the change to the medical status as a selected physiological measuring device, wherein the selected physiological measuring device collects physiological information associated with the user;

receiving the physiological information from the selected physiological measuring device;
submitting the physiological information and the change in medical status of the user over a network to a medical diagnostic system; 5
accessing prior diagnostic results supplied by the medical diagnostic system;
comparing a diagnostic analysis associated with the physiological information and the change in medical status of the user with the prior diagnostic results; 10
determining whether a health condition of the user has changed based on the Comparing;
presenting the diagnostic analysis and a determined health condition change to equipment of a medical agent of the user, wherein the medical agent is presented the diagnostic analysis by way of the avatar; 15
receiving from the equipment of the medical agent a prognosis and prescription determined from the diagnostic analysis and the determined health condition change; and 20
presenting the user with the health condition, the prognosis and the prescription by way of the avatar, wherein the processor provides interactive television services to the user.

* * * * *

25

专利名称(译)	用于执行生理信息的诊断分析和系统和方法		
公开(公告)号	US9408537	公开(公告)日	2016-08-09
申请号	US12/271600	申请日	2008-11-14
[标]申请(专利权)人(译)	AT&T知识产权一部有限合伙公司		
申请(专利权)人(译)	AT & T公司的知识产权我, L.P.		
当前申请(专利权)人(译)	AT & T公司的知识产权I, LP		
[标]发明人	SCHROETER HORST CHANG E LEE ROBERTS LINDA KHANDELWAL MADHUR CLAYTON DARNELL		
发明人	SCHROETER, HORST CHANG, E-LEE ROBERTS, LINDA KHANDELWAL, MADHUR CLAYTON, DARNELL		
IPC分类号	G06F19/00 A61B5/00 G06N3/00		
CPC分类号	G06F19/3418 G06F19/363 A61B5/0022 G06N3/006 A61B5/4842 G06F19/36 A61B5/744 G06F19/345 A61B5/14551 A61B5/01 A61B5/021 A61B5/02416 A61B5/14532 A61B5/4872 A61B5/7246 A61B5/ 7465 G16H10/20 G16H10/60 G16H40/63 G16H50/20		
审查员(译)	JACKSON, GARY		
其他公开文献	US20100125182A1		
外部链接	Espacenet USPTO		

摘要(译)

结合本公开的教导的系统可以包括,例如,具有用于检索用户的用户简档的控制器的化身引擎,向用户呈现具有与用户简档相关的特征的化身,检测一个或多个响应。在用户和化身之间的通信交换期间,用户从一个或多个响应中识别出确定用户的医疗状态的需要,与医疗诊断系统建立通信,接收与用户相关联的生理信息,提交生理信息信息到医疗诊断系统,从医疗诊断系统接收生理信息的诊断分析,并将诊断分析呈现给用户和用户的医疗代理中的至少一个,其中通过以下方式向用户呈现诊断分析:化身的方式。公开了其他实施例。

