



US007400919B2

(12) **United States Patent**
Petersen et al.

(10) **Patent No.:** **US 7,400,919 B2**
(45) **Date of Patent:** **Jul. 15, 2008**

(54) **OXIMETER AMBIENT LIGHT CANCELLATION**
(75) Inventors: **Ethan Petersen**, Castro Valley, CA (US);
William Shea, Livermore, CA (US);
Bradford B. Chew, San Ramon, CA (US)

(73) Assignee: **Nellcor Puritan Bennett LLC**, Boulder, CO (US)

(*) Notice: Subject to any disclaimer, the term of this patent is extended or adjusted under 35 U.S.C. 154(b) by 130 days.

(21) Appl. No.: **11/495,415**

(22) Filed: **Jul. 28, 2006**

(65) **Prior Publication Data**

US 2006/0264721 A1 Nov. 23, 2006

Related U.S. Application Data

(62) Division of application No. 10/787,854, filed on Feb. 25, 2004, now Pat. No. 7,190,985.

(51) **Int. Cl.**
A61B 5/1455 (2006.01)

(52) **U.S. Cl.** **600/323**

(58) **Field of Classification Search** **600/322, 600/323, 331**

See application file for complete search history.

(56) **References Cited**

U.S. PATENT DOCUMENTS

4,802,486 A 2/1989 Goodman et al.

4,911,167 A	3/1990	Corenman et al.
4,928,692 A	5/1990	Goodman et al.
4,934,372 A	6/1990	Corenman et al.
5,351,685 A	10/1994	Potratz
5,368,026 A	11/1994	Swedlow et al.
5,368,224 A	11/1994	Richardson et al.
5,645,060 A	7/1997	Yorkey
5,662,106 A	9/1997	Swedlow et al.
5,713,355 A	2/1998	Richardson et al.
5,746,697 A	5/1998	Swedlow et al.
5,803,910 A	9/1998	Potratz
5,846,190 A	12/1998	Woehrl
5,921,921 A	7/1999	Potratz et al.
5,924,979 A	7/1999	Swedlow et al.
5,954,644 A	9/1999	Dettling et al.
6,226,539 B1	5/2001	Potratz
2001/0002206 A1	5/2001	Diab et al.
2003/0028357 A1	2/2003	Noris et al.

Primary Examiner—Eric F. Winakur

Assistant Examiner—Etsub D Berhanu

(74) *Attorney, Agent, or Firm*—Fletcher Yoder

(57) **ABSTRACT**

A pulse oximeter method and apparatus which provides (1) a notch filter at a distance between a modulation frequency and a common multiple of commonly used power line frequencies (**50, 60, 100 and 120**) and also (2) a demodulation frequency greater than a highest pulse rate of a person and lower than any harmonic of 50, 60, 100 or 120 Hz, to filter ambient light interference, while choosing an optimum demodulation frequency that avoids interference from the notch filter or from harmonics of the line interference. Also, ambient light for any low frequency interference, such as power line interference, is measured both before and after each of the light emitter wavelengths and the average of the ambient light is then subtracted from the detected signal.

18 Claims, 3 Drawing Sheets

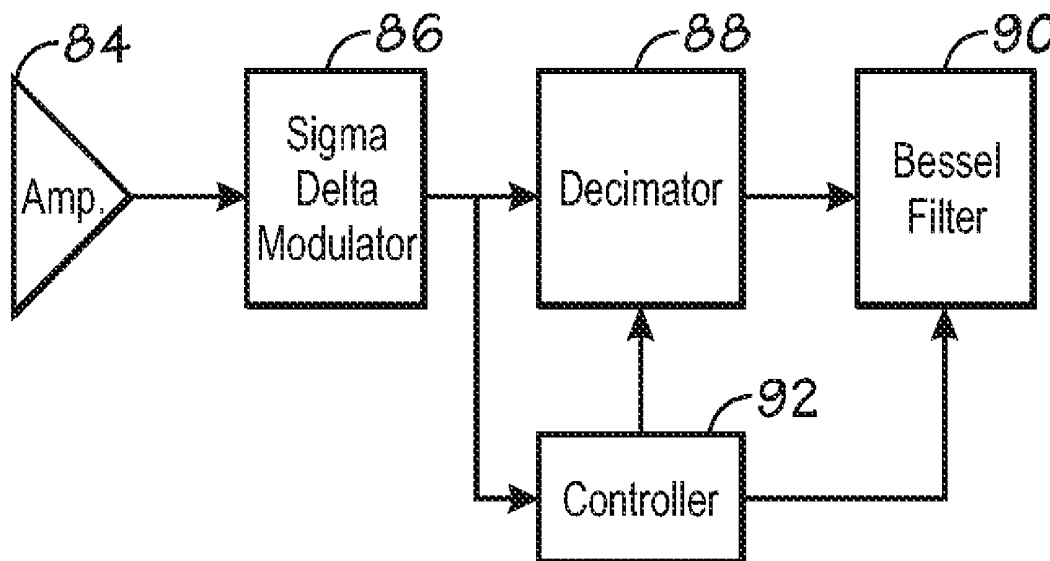

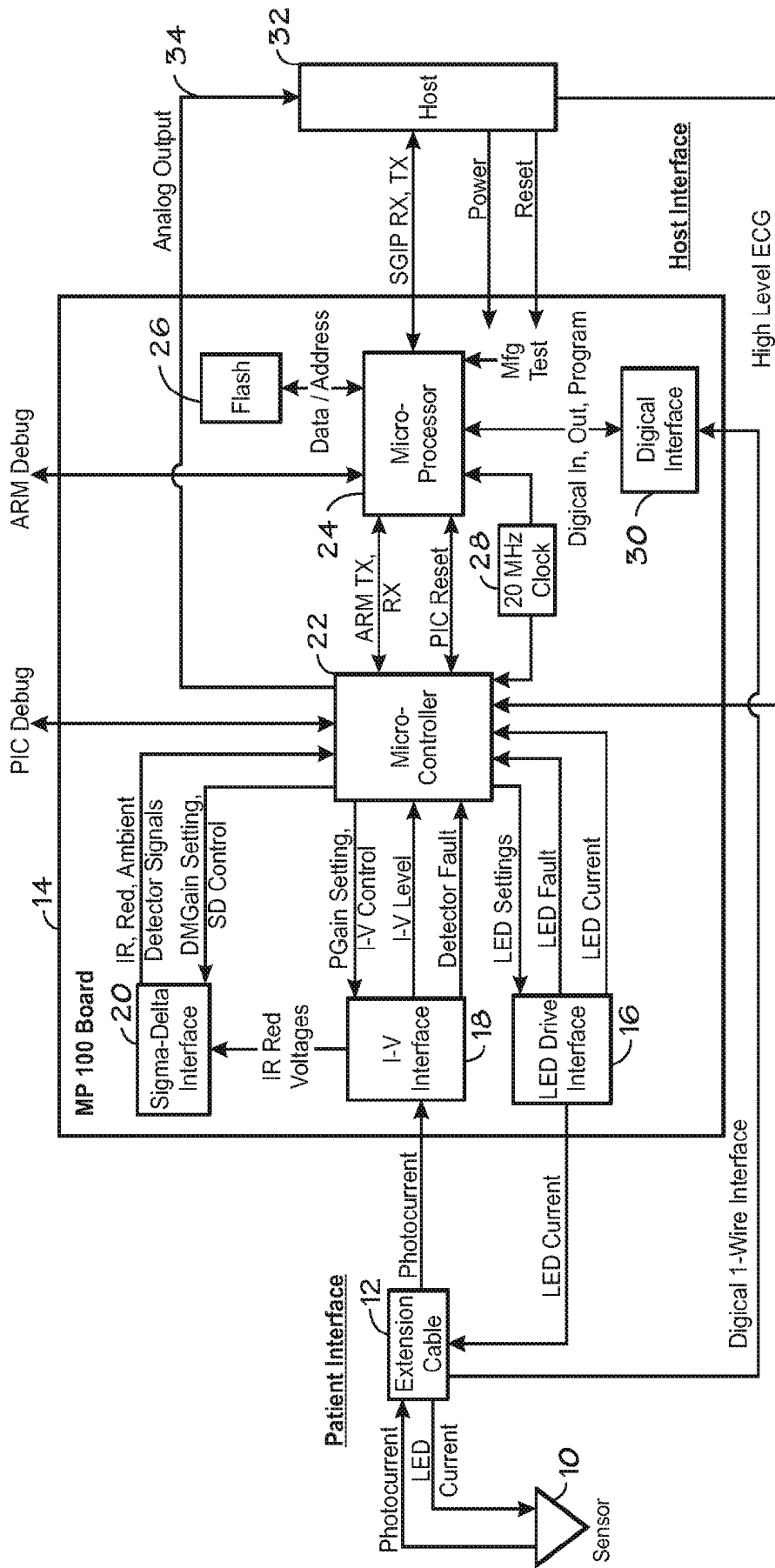

FIG. 1

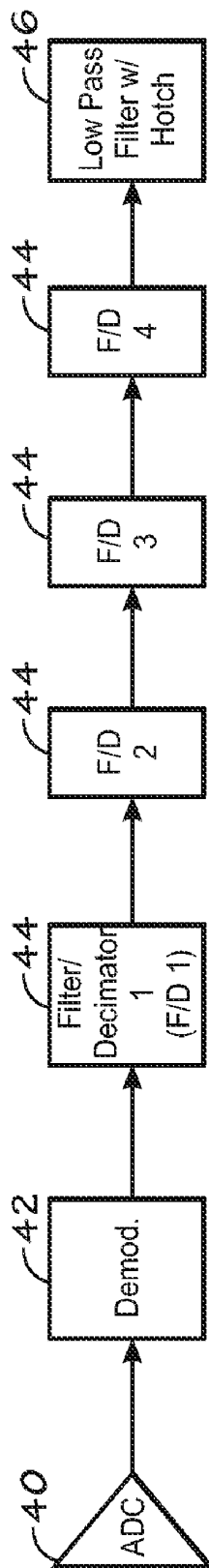
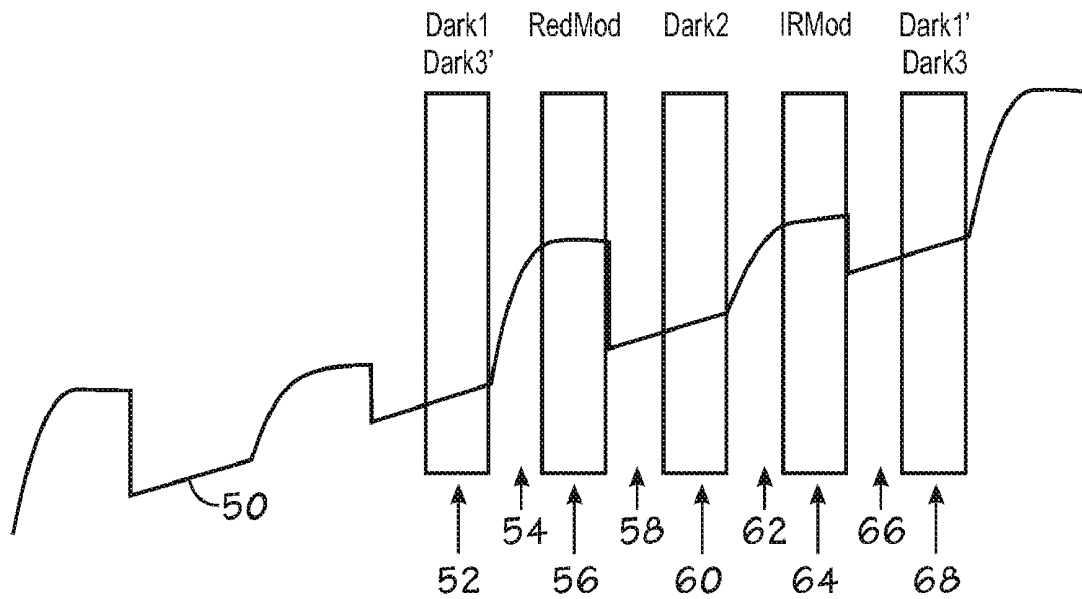

FIG. 2



$$Red = RedMod - \frac{Dark1 + Dark2}{2}$$

$$IR = IRMod - \frac{Dark2 + Dark3}{2}$$

FIG. 3

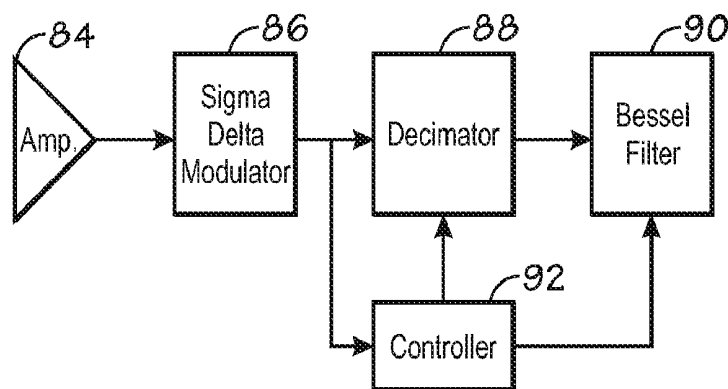

FIG. 4

OXIMETER AMBIENT LIGHT CANCELLATION

CROSS-REFERENCE TO RELATED APPLICATIONS

This application is a divisional of Ser. No. 10/787,854, filed Feb. 25, 2004 now U.S. Pat. No. 7,190,985.

BACKGROUND OF THE INVENTION

The present invention relates to oximeters, and in particular to techniques for ambient light cancellation in pulse oximeters.

Pulse oximetry is typically used to measure various blood flow characteristics including, but not limited to, the blood-oxygen saturation of hemoglobin in arterial blood, the volume of individual blood pulsations supplying the tissue, and the rate of blood pulsations corresponding to each heartbeat of a patient. Measurement of these characteristics has been accomplished by use of a non-invasive sensor which scatters light through a portion of the patient's tissue where blood perfuses the tissue, and photoelectrically senses the absorption of light in such tissue. The amount of light absorbed is then used to calculate the amount of blood constituent being measured.

The light scattered through the tissue is selected to be of one or more wavelengths that are absorbed by the blood in an amount representative of the amount of the blood constituent present in the blood. The amount of transmitted light scattered through the tissue will vary in accordance with the changing amount of blood constituent in the tissue and the related light absorption. For measuring blood oxygen level, such sensors have typically been provided with a light source that is adapted to generate light of at least two different wavelengths, and with photodetectors sensitive to both of those wavelengths, in accordance with known techniques for measuring blood oxygen saturation.

Known non-invasive sensors include devices that are secured to a portion of the body, such as a finger, an ear or the scalp. In animals and humans, the tissue of these body portions is perfused with blood and the tissue surface is readily accessible to the sensor.

One problem with oximeter measurements is that in addition to receiving the light that was directed at the tissue, ambient light is also detected by the photodetector. Attempts can be made to block out ambient light, but some amount of ambient light will typically be detected. One particular concern is the light at the power line frequency of fluorescent or other lights, which is 60 Hz in the United States and 50 Hz in Europe and other countries.

Since a single photodetector is typically used, the light of different wavelengths, such as red and infrared, is time multiplexed. The detected signal must be demultiplexed. The demultiplexing frequency must be high enough so that it is much larger than the pulse rate. However, choosing a demultiplexing frequency is also impacted by the ambient light interference. One issue is the aliasing of harmonics of the AC power line frequency. U.S. Pat. No. 5,713,355 discusses a technique of altering the demultiplexing frequency depending upon the amount of ambient interference detected at each frequency.

U.S. Pat. No. 5,885,213 discusses subtracting a dark signal (detected ambient light) from the detected light signal. This is accomplished by leaving both the red and infrared light emitters off, in between turning them on, so that a "dark" signal supposedly composed of the ambient light present can be

detected. This can then be subtracted from the desired signal. Other examples of patents dealing with the ambient light issue are U.S. Pat. Nos. 6,385,471, 5,846,190 and U.S. Pat. No. 4,781,195.

U.S. Pat. No. 6,449,501 discusses using a notch filter to filter out line frequency. However, the sampling rate is described as being set to twice the fundamental frequency of the power line interference, leaving higher harmonics of the power line interference as a problem, and it is unclear how the interference can be filtered without filtering the modulation frequency. Another example of a notch filter being used is set forth in U.S. Pat. No. 4,802,486, which uses a notch filter for the EKG signal.

BRIEF SUMMARY OF THE INVENTION

The present invention provides a pulse oximeter method and apparatus which provides (1) a notch filter at a distance between a demodulation frequency and a common multiple of commonly used power line frequencies (**50, 60, 100, and 120**) and also (2) a demodulation frequency greater than a highest pulse rate of a person and lower than any harmonic of 50, 60, 100, or 120 Hz. The invention thus allows the filtering of a significant source of ambient light interference, while choosing an optimum demodulation frequency that avoids interference from the notch filter or from harmonics of the power line interference.

In one embodiment, the common multiple is 1200, with the demodulation frequency being between 5 and 20 Hz away from 1200, preferably approximately 1211 in one embodiment.

In another aspect of the invention, dark signals, or ambient light, are measured both before and after each of the light emitter wavelengths (red and infrared in one embodiment). Instead of simply subtracting one of the dark levels, the two dark levels are averaged and then subtracted from the detected signal. This compensates for a variation in ambient light during the detected signal, reducing the effect of power line interference or any other low frequency interference.

In another aspect of the present invention, digital filtering and decimation are done in the digital domain. When there is a change in a gain setting on the front end hardware, or in the LED power, the filters are preloaded to put values in their memory to correspond to an estimate of the settled value of the output at the new gain or power settings. This preloading speeds up when valid data will be available at the output of the filter.

BRIEF DESCRIPTION OF THE DRAWINGS

FIG. 1 is a block diagram of an oximeter incorporating the present invention.

FIG. 2 is a block diagram of a portion of the digital manipulations in one embodiment of the invention, including a notch filter.

FIG. 3 is a diagram illustrating the multiple dark levels that are averaged in an embodiment of the invention.

FIG. 4 is a diagram illustrating the preloading of the digital filter and decimator according to an embodiment of the present invention.

DETAILED DESCRIPTION OF THE INVENTION

Overall System

FIG. 1 illustrates an embodiment of an oximetry system incorporating the present invention. A sensor **10** includes red

and infrared LEDs and a photodetector. These are connected by a cable 12 to a board 14. LED drive current is provided by an LED drive interface 16. The received photocurrent from the sensor is provided to an I-V interface 18. The IR and red voltages are then provided to a sigma-delta interface 20 incorporating the present invention. The output of sigma-delta interface 20 is provided to a microcontroller 22. Microcontroller 22 includes flash memory for a program, and EEPROM memory for data. The oximeter also includes a microprocessor chip 24 connected to a flash memory 26. Finally, a clock 28 is used and an interface 30 to a digital calibration in the sensor 10 is provided. A separate host 32 receives the processed information, as well as receiving an analog signal on a line 34 for providing an analog display.

Notch Filter

FIG. 2 shows an analog-to-digital converter 40 which provides a digital signal to be manipulated by microcontroller 22 of FIG. 1. The microprocessor would include a demodulator 42, four stages of filter/decimators 44, a low pass filter with a notch 46, as well as other blocks for digital manipulation of the signals and calculation of oxygen saturation as is well known in the art. Only the red channel is shown after the demodulation, but a similar channel is used for the IR signal.

Notch filter 46 deals with power line interference which, in the United States, comes from lights which operate on 60 Hz or 120 Hz, depending upon the power requirements. Europe and other areas use 50 Hz and 100 Hz. A common multiple of 50, 60, 100, and 120 Hz is 1200 Hz. The modulation bandwidth is chosen to be higher than the highest possible human pulse rate, preferably higher than 5 Hz. At the same time, it is chosen to be lower than any harmonic of the power line interference signals. Twenty hertz is chosen as a desirable upper limit because a second harmonic of 2450 will alias in at 2025 Hz. In one embodiment, the modulation frequency chosen is 1211.23 Hz. This is 11.23 Hz distant from 1200 Hz. (within a range of 5-20 Hz). Accordingly, in a preferred embodiment, a zero is provided in the notch filter at 11.23 Hz. The low pass filter with notch (46), in one embodiment, is an 8 pole Bessel filter with a notch at 11.25 Hz.

The present invention thus provides an effective means of eliminating interference from power line interference, such as the ripple on fluorescent lights which can alias onto the detected signal. Although anti-aliasing filters have been provided in hardware before a demodulator, it is difficult to make these effective, and thus there will be some residual line interference in the detected signal to be dealt with in the digital domain.

Averaging Ambient Dark Levels to Reduce Low Frequency Interference

FIG. 3 illustrates another aspect of the present invention, reducing ambient interference by averaging the ambient dark levels before and after a sampling period to account for low frequency interference from power lines or other sources. FIG. 3 shows a signal at a sampling rate of 2400. The upward sloping line in FIG. 3 is due to 60 Hz power line interference. It is desirable to eliminate the effect of this upward slope (which will be downward on other parts of the 60 Hz (or 50 Hz, etc.) signal).

FIG. 3 shows a detected signal during different periods of modulation. The detected signal level is illustrated by a line 50. During a first dark period 52, neither the red nor IR LED are on, allowing a sampling of the dark, or ambient, light. After this sampling, during a time period 54, the red LED is turned on, with signal 50 rising during this period as the red LED comes on to its full intensity. During the time period 56, the detected signal corresponds to the red LED being on.

After the red LED is turned off and the signal decays during a period 58, a second dark period 60 is sampled.

Subsequently, the IR LED is turned on during a period 62, and sampled during a period 64. It is turned off and the signal decays during a period 66, with a third dark sample being taken during a period 68. The third dark sample also corresponds to the first dark period 52, as the process repeats itself.

As can be seen from FIG. 3, if only one of the dark levels is used, an inaccurate ambient level may be measured if the ambient level is varying, such as due to a low frequency interference. By averaging the dark periods before and after the sampling period for a particular wavelength, a more accurate measurement of the ambient dark level signal is obtained. For example, the ambient interference during the red modulation period 56 is determined by measuring the dark 1 signal during period 52 and the dark 2 signal during period 60 and averaging these signals. Similarly, for the infrared modulation period 64, the dark 2 signal during period 60 and the dark 3 signal during period 68 are averaged and subtracted from the detected IR signal to eliminate the ambient interference. All of these calculations are done in the digital domain by microcontroller 22 of FIG. 1.

Preloading Decimation and Bessel Filters

FIG. 4 illustrates another aspect of the present invention where filters and software are preloaded. Before the analog input signal is processed through the sigma-delta modulator and multi-bit analog digital converter, it is typically amplified in a hardware amplifier 84. After processing by the sigma-delta modulator 86 and conversion into digital domain, it is decimated to reduce the sample rate by a decimator 88 and filtered by a Bessel filter 88. A controller 92 pre-loads the memories of the Bessel filter and decimator with an estimate of what the settled value of the output would be. This will significantly reduce the settling time of the filter after a step change in its input. Such a step change in the input can occur from a change in the gain settings of the amplifier 84. Alternately, a step change can be the result of a change in the particular LED being activated, the power of the LED, or other gain settings of the front end hardware. Since the controller 92 would be activating such changes, it will have the knowledge of when to pre-load the filter and decimator with the appropriate values. Although these are shown as blocks in FIG. 4, it is understood that in the preferred embodiment this is done by a software program which functions as controller 92, filter 88 and decimator 90. This preloading of the filter and decimator provides that valid data is available sooner by shortening the settling time.

As will be understood by those skilled in the art, the present invention may be embodied in other specific forms without departing from the essential characteristics thereof. For example, more than two different wavelengths of light could be used. Alternately, a different demodulation frequency could be chosen. In addition, the notch filtering can be done either before or after other digital processing of the detected signal. Accordingly, the foregoing description is intended to be illustrative, but not limiting, of the scope of the invention which is set forth in the following claims.

What is claimed is:

1. An oximeter apparatus comprising:
 - an amplifier configured to amplify an analog sensor signal to provide an amplified analog sensor signal;
 - a sigma-delta modulator having an input coupled to receive the amplified analog sensor signal;
 - a multiple bit analog-to-digital converter coupled to an output of the sigma-delta modulator to provide a digital signal;

5

a decimator configured to receive the digital signal and output a decimated signal;
 a digital filter configured to the decimated signal; and
 a controller configured to preload the decimator and digital filter with an estimate of a settled output value.

2. The oximeter apparatus, as set forth in claim 1, wherein the amplifier comprises a hardware amplifier.

3. The oximeter apparatus, as set forth in claim 1, wherein the digital filter comprises a Bessel filter.

4. The oximeter apparatus, as set forth in claim 1, wherein the controller comprises a control program.

5. The oximeter apparatus, as set forth in claim 1, wherein the controller is configured to preload the decimator and the digital filter after a step change in the decimated signal.

6. The oximeter apparatus, as set forth in claim 1, wherein the controller is configured to preload the decimator and the digital filter in response to a change in a gain setting of the amplifier.

7. The oximeter apparatus, as set forth in claim 1, wherein the controller is configured to preload the decimator and the digital filter in response to a change in an LED associated with the analog sensor signal being activated.

8. The oximeter apparatus, as set forth in claim 1, wherein the controller is configured to preload the decimator and the digital filter in response to a power change in an LED associated with the analog sensor signal.

9. The oximeter apparatus, as set forth in claim 1, wherein the controller is configured to preload the decimator and the digital filter in response to the controller changing a setting of the oximeter apparatus.

10. A method of operating an oximeter apparatus comprising:

amplifying an analog sensor signal to provide an amplified analog sensor signal;

6

modulating the amplified analog sensor signal with a sigma-delta modulator to provide a modulated signal; converting the modulated signal into a digital signal with a multiple bit analog-to-digital converter;

5 decimating the digital signal with a decimator to provide a decimated signal;

filtering the decimated signal with a digital filter; and preloading the decimator and digital filter with an estimate of a settled output value.

10 11. The method, as set forth in claim 10, wherein amplifying comprises using a hardware amplifier.

12. The method, as set forth in claim 10, wherein filtering comprises using a Bessel filter.

15 13. The method, as set forth in claim 10, wherein preloading comprises using a controller.

14. The method, as set forth in claim 10, wherein preloading comprises preloading the decimator and the digital filter after a step change in the decimated signal.

15 15. The method, as set forth in claim 10, wherein preloading comprises preloading the decimator and the digital filter in response to a change in a gain setting of an amplifier used to amplify the analog sensor signal.

16. The method, as set forth in claim 10, wherein preloading comprises preloading the decimator and the digital filter in response to a change in an LED associated with the analog sensor signal being activated.

17. The method, as set forth in claim 10, wherein preloading comprises preloading the decimator and the digital filter in response to a power change in an LED associated with the analog sensor signal.

18. The method, as set forth in claim 10, wherein preloading comprises preloading the decimator and the digital filter in response to a controller changing a setting of the oximeter apparatus.

* * * * *

专利名称(译)	血氧计环境光消除		
公开(公告)号	US7400919	公开(公告)日	2008-07-15
申请号	US11/495415	申请日	2006-07-28
[标]申请(专利权)人(译)	内尔科尔普里坦贝内特公司		
申请(专利权)人(译)	NELLCOR PURITAN BENNETT注册成立的股份有限公司特拉华		
当前申请(专利权)人(译)	COVIDIEN LP		
[标]发明人	PETERSEN ETHAN SHEA WILLIAM CHEW BRADFORD B		
发明人	PETERSEN, ETHAN SHEA, WILLIAM CHEW, BRADFORD B.		
IPC分类号	A61B5/1455 A61B5/00 A61B5/024		
CPC分类号	A61B5/14551 A61B5/7203 A61B5/7228 A61B5/7278 A61B5/14552 A61B5/7225 A61B5/725 A61B5/0205 A61B5/02416		
其他公开文献	US20060264721A1		
外部链接	Espacenet USPTO		

摘要(译)

一种脉冲血氧计方法和装置，其在调制频率和常用电力线频率（50,60,100和120）的公倍数之间的距离处提供（1）陷波滤波器，并且还提供（2）大于的解调频率。一个人的最高脉冲率，低于50,60,100或120 Hz的任何谐波，以滤除环境光干扰，同时选择最佳解调频率，避免陷波滤波器的干扰或线路干扰的谐波。此外，在每个光发射器波长之前和之后测量用于任何低频干扰（例如电力线干扰）的环境光，然后从检测到的信号中减去环境光的平均值。

