



US007392077B2

(12) **United States Patent**
Mueller et al.

(10) **Patent No.:** **US 7,392,077 B2**
(45) **Date of Patent:** **Jun. 24, 2008**

(54) **METHOD FOR TREATING A PATIENT AT RISK OF LOSS OF CARDIAC FUNCTION BY CARDIAC ISCHEMIA**

3,952,742 A 4/1976 Taylor
4,296,100 A 10/1981 Franco
4,531,936 A 7/1985 Gordon
4,657,536 A 4/1987 Dorman
4,770,653 A 9/1988 Shturman

(75) Inventors: **Richard L. Mueller**, Byron, CA (US);
U. Hiram Chee, Santa Cruz, CA (US)

(73) Assignee: **Boston Scientific Scimed, Inc.**, Maple Grove, MN (US)

(Continued)

(*) Notice: Subject to any disclaimer, the term of this patent is extended or adjusted under 35 U.S.C. 154(b) by 723 days.

FOREIGN PATENT DOCUMENTS

WO WO 96/32129 10/1996

(21) Appl. No.: **10/822,600**

(22) Filed: **Apr. 12, 2004**

(Continued)

(65) **Prior Publication Data**

US 2004/0254451 A1 Dec. 16, 2004

OTHER PUBLICATIONS

Sachinopoulou et al. Invited Review Transmyocardial Revascularization. *Lasers in Medical Science* 1995, 10:83-91.*

Related U.S. Application Data

(Continued)

(62) Division of application No. 09/706,584, filed on Nov. 3, 2000, now Pat. No. 6,748,258.

(60) Provisional application No. 60/163,698, filed on Nov. 5, 1999.

Primary Examiner—Ruth S Smith
(74) *Attorney, Agent, or Firm*—Jones Day

(51) **Int. Cl.**
A61B 5/00 (2006.01)

(57) **ABSTRACT**

(52) **U.S. Cl.** 600/427; 600/508; 606/14; 606/27; 606/185; 604/20; 604/22; 604/57; 607/89; 607/99; 601/2

Various methods and devices for treating a patient who has lost, or is at risk of losing cardiac function by cardiac ischemia are disclosed. Treatment includes first imaging a patient's heart, or a portion thereof, to identify underperfused regions of cardiac muscle, and a source of oxygenated blood that is proximate to the underperfused region. Between the underperfused regions and the oxygenated blood source, a target area is selected where thermal or mechanical injury is introduced, and optionally reintroduced, to convert initial capillary blush, resulting from the injury.

(58) **Field of Classification Search** 606/13-17, 606/41, 2, 27, 28, 167, 185; 600/407, 425, 600/427, 439, 481, 508; 601/2, 3; 604/20-22, 604/57; 607/88, 89, 96, 99
See application file for complete search history.

(56) **References Cited**
U.S. PATENT DOCUMENTS

3,773,034 A 11/1973 Burns et al.

18 Claims, 14 Drawing Sheets

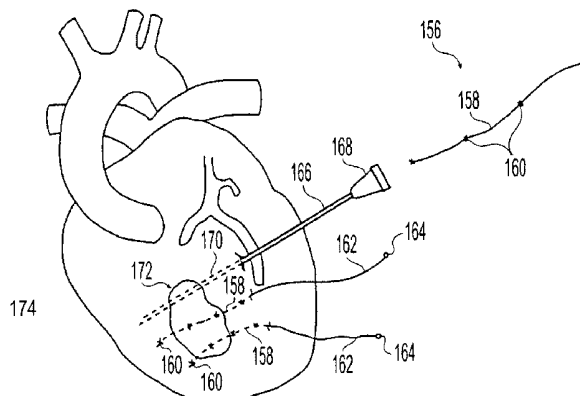

U.S. PATENT DOCUMENTS

4,911,148 A	3/1990	Sosnowski et al.	
4,946,442 A	8/1990	Sanagi	
4,994,033 A	2/1991	Shockey et al.	
5,061,223 A	10/1991	Yock	
5,185,004 A	2/1993	Lashinski	
5,203,772 A	4/1993	Hammerslag et al.	
5,244,460 A	9/1993	Unger et al.	
5,385,148 A	1/1995	Lesh et al.	
5,419,777 A	5/1995	Hofling	
5,421,331 A *	6/1995	Devito et al.	600/425
5,489,575 A	2/1996	Lee et al.	
5,499,971 A	3/1996	Shapland et al.	
5,507,724 A	4/1996	Hofmann et al.	
5,569,160 A	10/1996	Sauer et al.	
5,569,217 A	10/1996	Luther	
5,571,215 A	11/1996	Sterman et al.	
5,591,195 A	1/1997	Taheri et al.	
5,653,684 A	8/1997	Laptewicz et al.	
5,661,133 A	8/1997	Leiden et al.	
5,662,124 A	9/1997	Wilk	
5,685,853 A	11/1997	Bonnet	
5,693,029 A	12/1997	Leonhardt	
5,698,531 A	12/1997	Nabel et al.	
5,725,523 A *	3/1998	Mueller	606/15
5,733,280 A	3/1998	Avitall	
5,785,702 A	7/1998	Murphy-Chutorian et al.	
5,797,870 A	8/1998	March et al.	
5,797,960 A	8/1998	Stevens et al.	
5,820,592 A	10/1998	Hammerslag	
5,827,216 A	10/1998	Igo et al.	
5,830,993 A	11/1998	Blecha et al.	
5,833,658 A	11/1998	Levy et al.	
5,840,031 A	11/1998	Crowley	
5,840,059 A	11/1998	March et al.	
5,840,062 A	11/1998	Gumaste et al.	
5,843,050 A	12/1998	Jones et al.	
5,846,221 A	12/1998	Snoko et al.	
5,857,464 A	1/1999	Desai	
5,860,953 A	1/1999	Snoko et al.	
5,865,738 A *	2/1999	Morcos et al.	600/365
5,871,495 A	2/1999	Mueller	
5,876,373 A	3/1999	Giba et al.	
5,882,332 A	3/1999	Wijay	
5,885,272 A	3/1999	Aita et al.	
5,891,133 A *	4/1999	Murphy-Chutorian	606/7
5,925,012 A	7/1999	Murphy-Chutorian et al.	
5,931,831 A	8/1999	Linder	
5,931,834 A	8/1999	Murphy-Chutorian et al.	
5,935,063 A	8/1999	Nguyen	
5,941,845 A	8/1999	Tu et al.	
5,941,868 A	8/1999	Kaplan et al.	
5,964,754 A	10/1999	Osyпка	
5,971,983 A	10/1999	Lesh	
5,993,443 A	11/1999	Murphy-Chutorian et al.	
5,997,525 A	12/1999	March et al.	
6,004,269 A	12/1999	Crowley et al.	
6,012,457 A	1/2000	Lesh	
6,023,135 A	2/2000	Gilbreth et al.	
6,024,703 A	2/2000	Zanelli et al.	
6,030,380 A *	2/2000	Auth et al.	606/41
6,063,022 A	5/2000	Ben-Haim	
6,121,246 A *	9/2000	Isner	514/44
6,121,775 A *	9/2000	Pearlman	324/309
6,133,233 A	10/2000	Ross et al.	
6,161,543 A	12/2000	Cox et al.	
6,171,303 B1	1/2001	Ben-Haim et al.	
6,174,871 B1 *	1/2001	Hammond et al.	514/44
6,179,809 B1	1/2001	Khairkahan et al.	
6,183,444 B1	2/2001	Glines et al.	
6,199,554 B1 *	3/2001	Mann et al.	128/898
6,224,584 B1	5/2001	March et al.	
6,237,605 B1	5/2001	Vaska et al.	
6,283,935 B1 *	9/2001	Laufer et al.	604/22
6,309,375 B1	10/2001	Glines et al.	
6,314,962 B1	11/2001	Vaska et al.	
6,314,963 B1	11/2001	Vaska et al.	

FOREIGN PATENT DOCUMENTS

WO	WO 97/25101	7/1997
WO	WO 97/47253	12/1997
WO	WO 99/39624	8/1999
WO	WO 00/57895	10/2000

OTHER PUBLICATIONS

- Deckelbaum, L.I., Cardiovascular Applications of Laser Technology, Lasers in Surgery and Medicine 15:315-341 (1994).
- Frazier, O.H., Myocardial Revascularization with Laser—Preliminary Findings, Circulation, 1995; 92 [suppl II:58-II-65].
- Padua et al., "Basic fibroblast growth factor is cardioprotective in ischemia-reperfusion injury" Molecular and Cellular Biochemistry 143: 129-135 (1995).
- Shi et al., "PR-39, a proline-rich antibacterial peptide that inhibits phagocyte NADPH oxidase activity by binding to Src homology 3 domains of p47phox" Proc. Natl. Acad. Sci. 93:6014-6018 (1996).
- Uchida et al., "Angiogenic therapy of acute myocardial infarction by intrapericardial injection of basic fibroblast growth factor and heparin sulfate: An experimental study" Am. Heart J., 130:1182-1188 (1995).
- Unger et al. "Basic fibroblast growth factor enhances myocardial collateral flow in a canine model" Am J. Physiol., 266:H1577-H1595 (1994).
- Walterberger et al., "Ischemia-Induced Transplant Arteriosclerosis in the Rat" Arteriosclerosis, Thrombosis and Vascular Biology 16(12):1516-1523 (1996).
- Xiaobing, et al. "Ischemia and Reperfusion reduce the Endogenous Basic Fibroblast Growth Factor (bf GF) in Rat Skeletal Muscles" Chinese Medical Journal 108(9): 699-703, (1995).

* cited by examiner

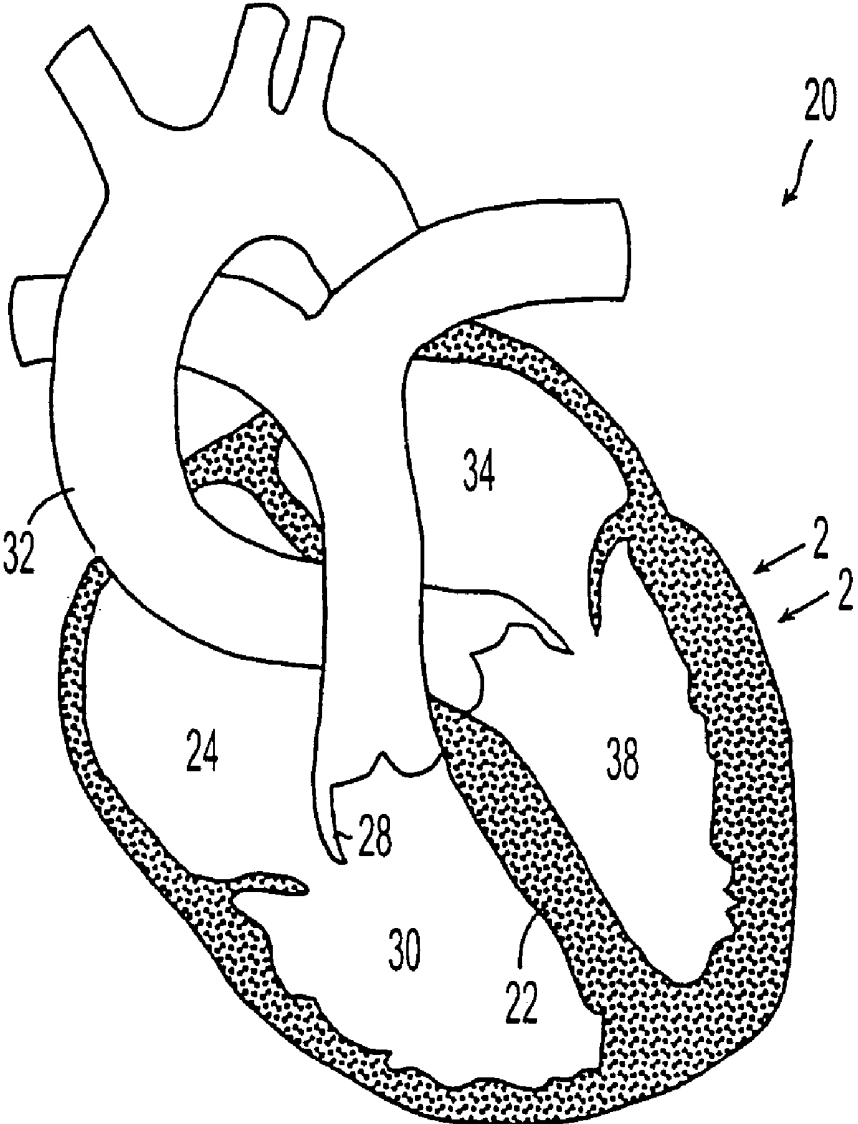

Fig. 1

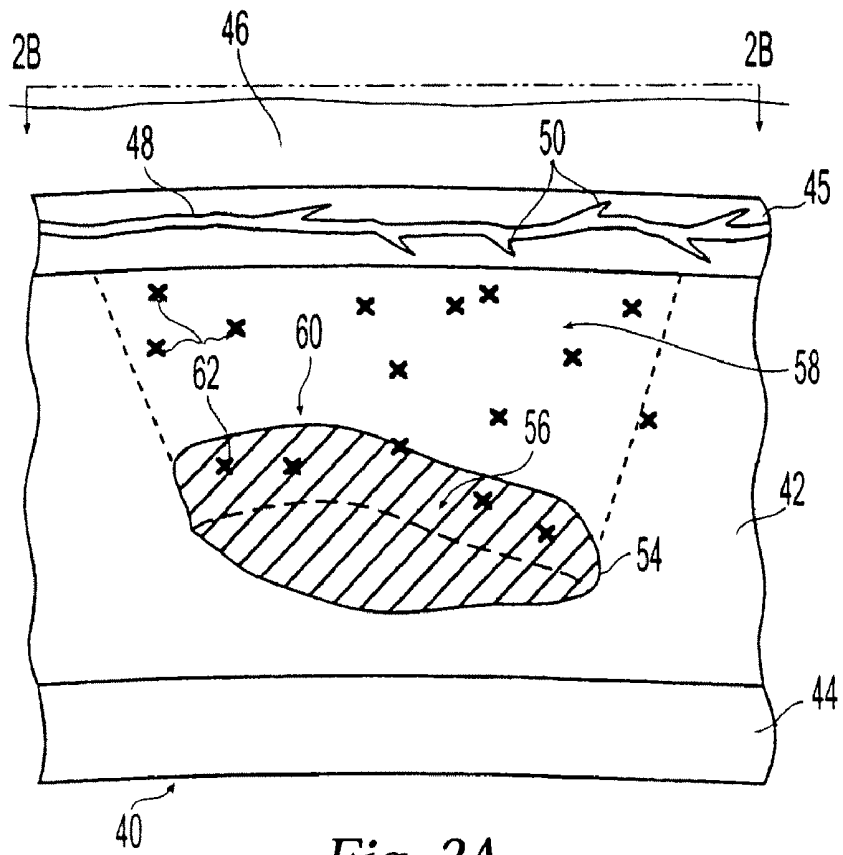

Fig. 2A

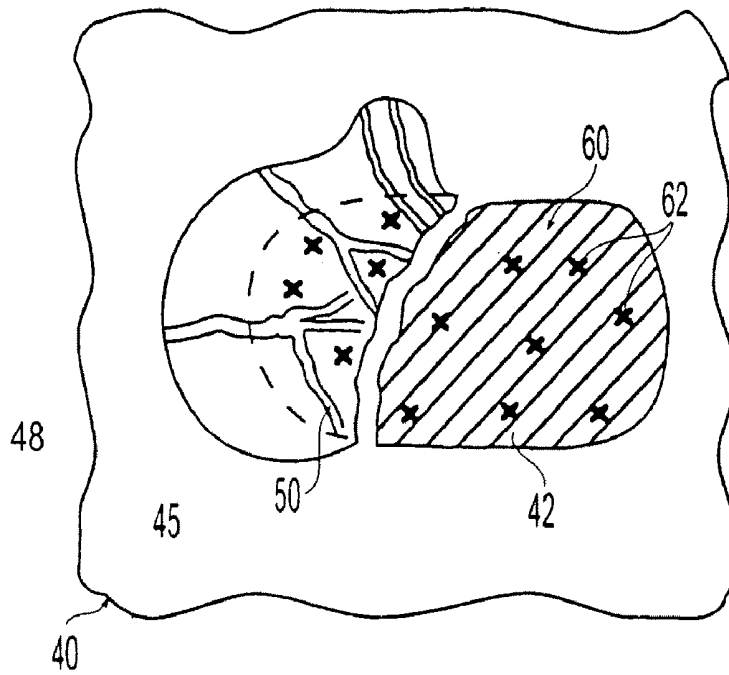

Fig. 2B

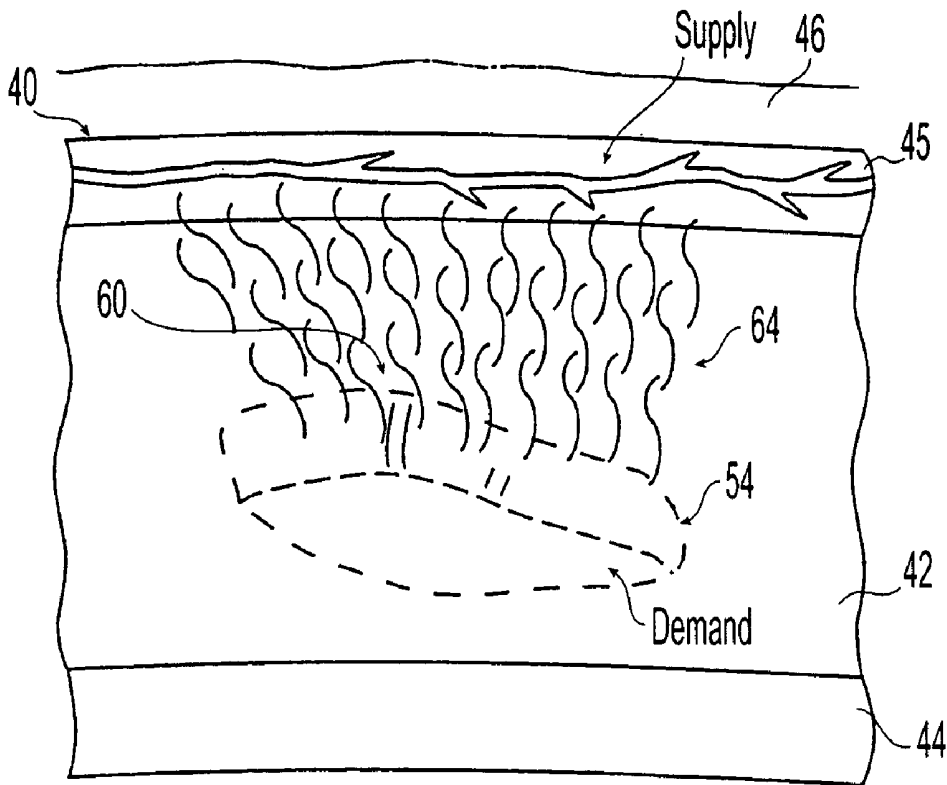

Fig. 3A

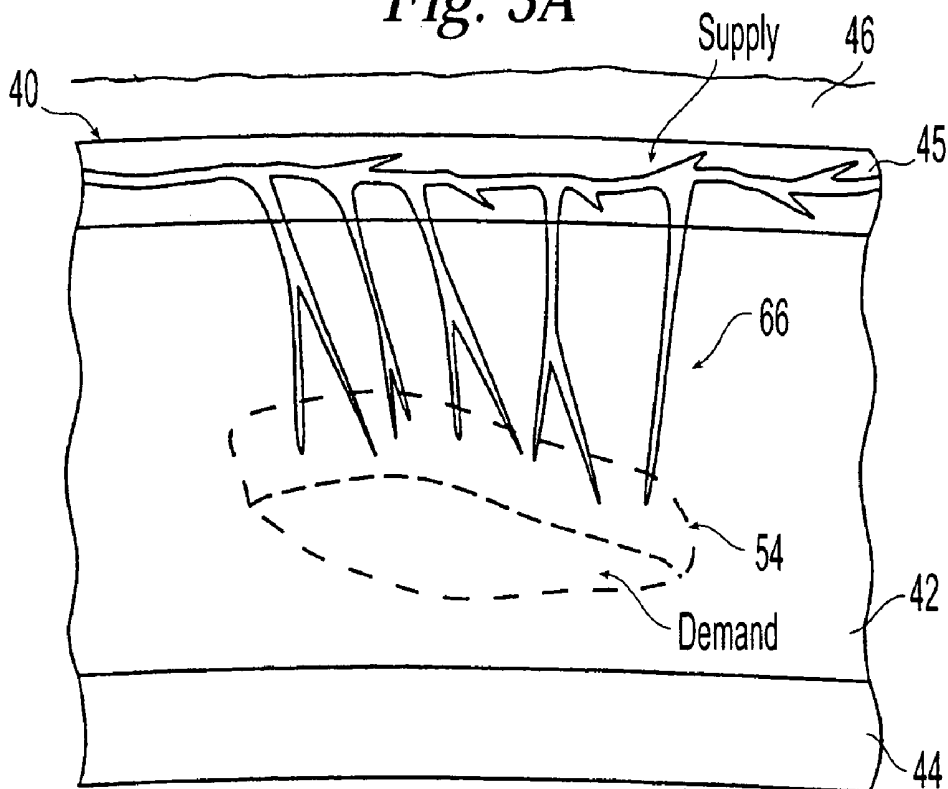

Fig. 3B

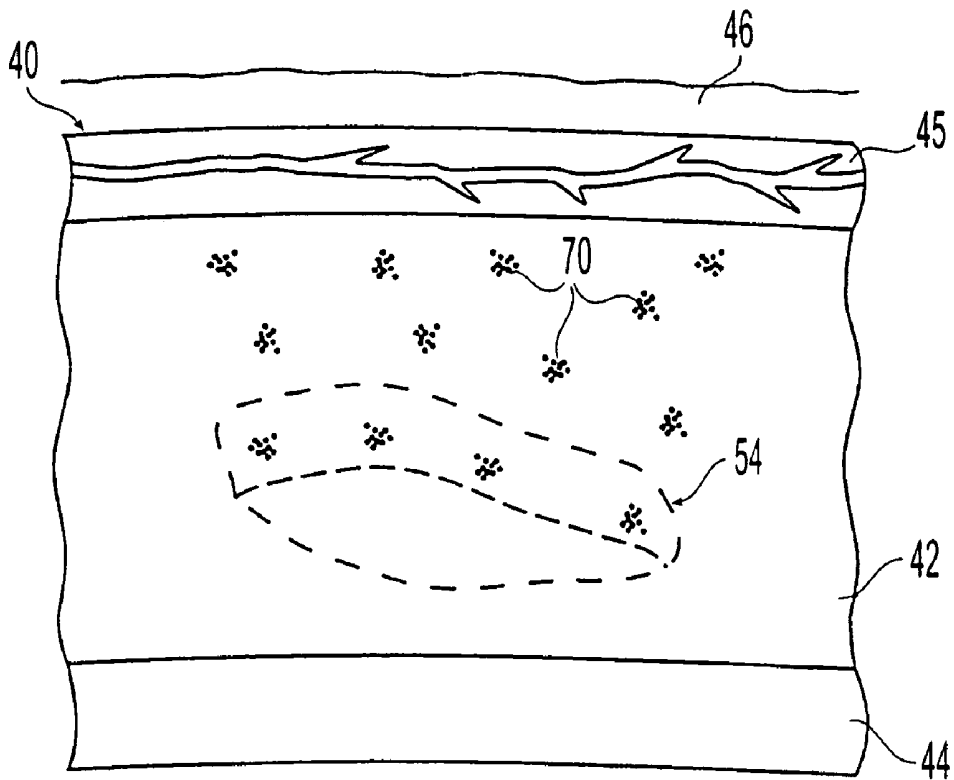

Fig. 4A

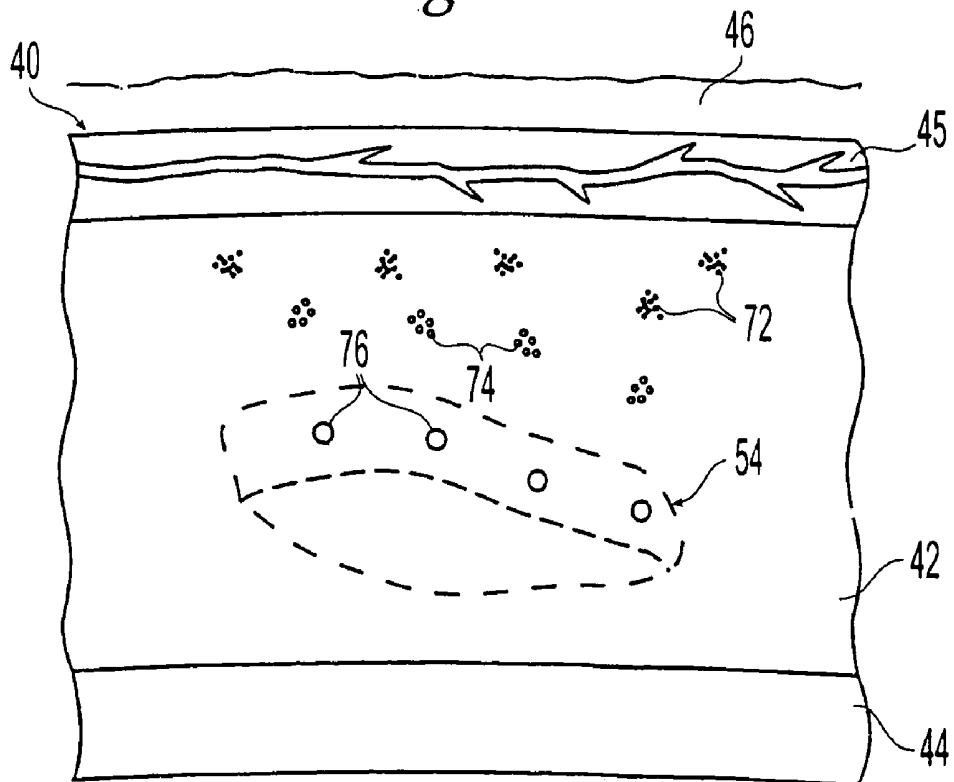

Fig. 4B

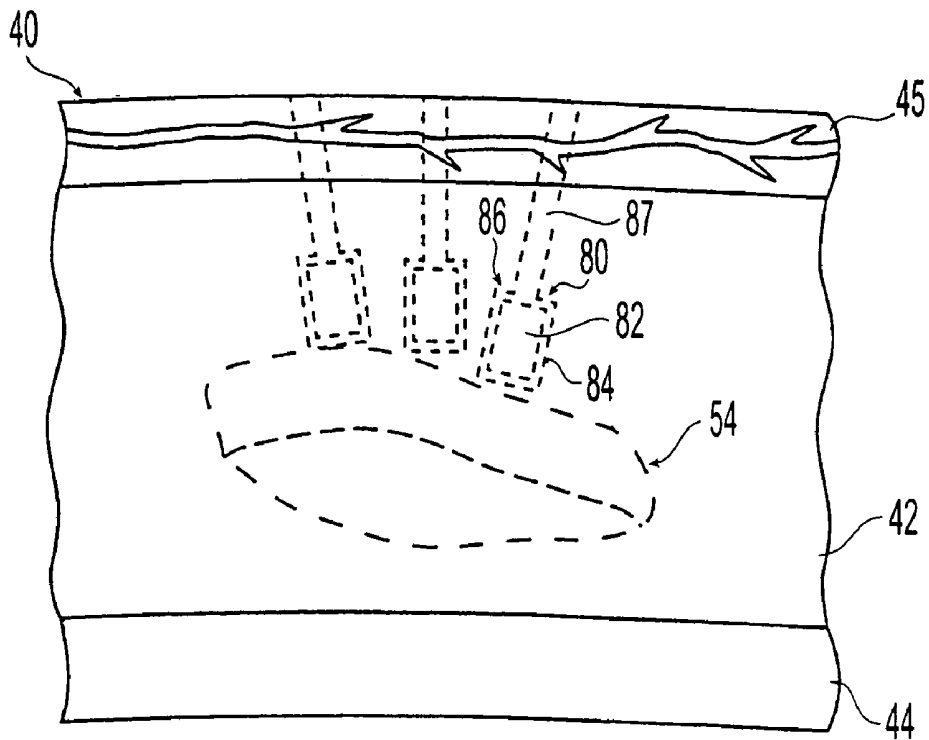

Fig. 5A

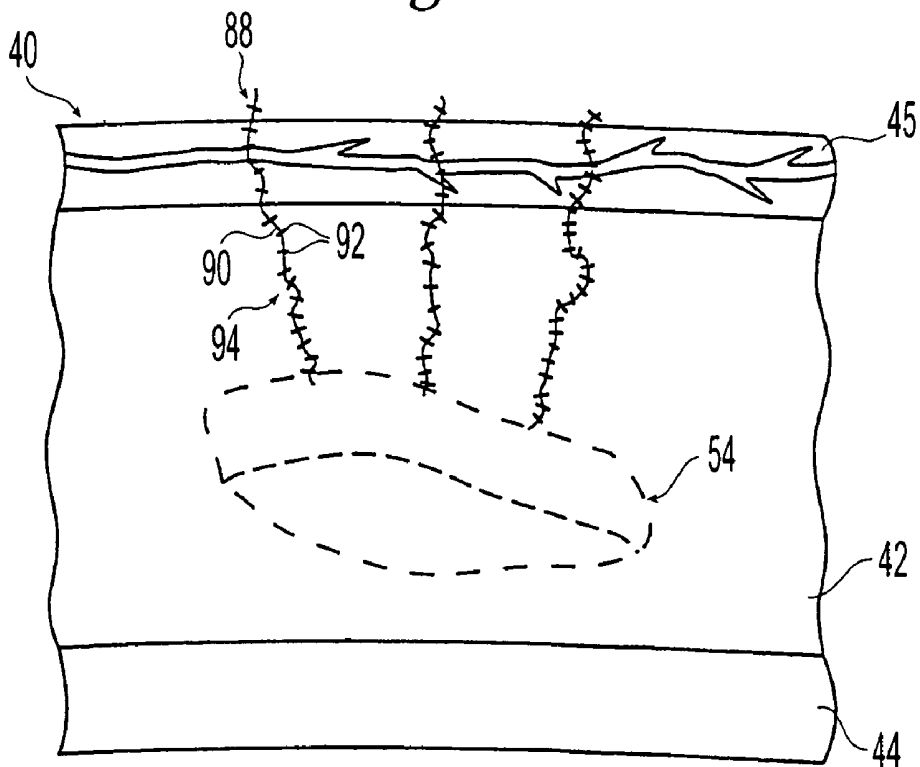

Fig. 5B

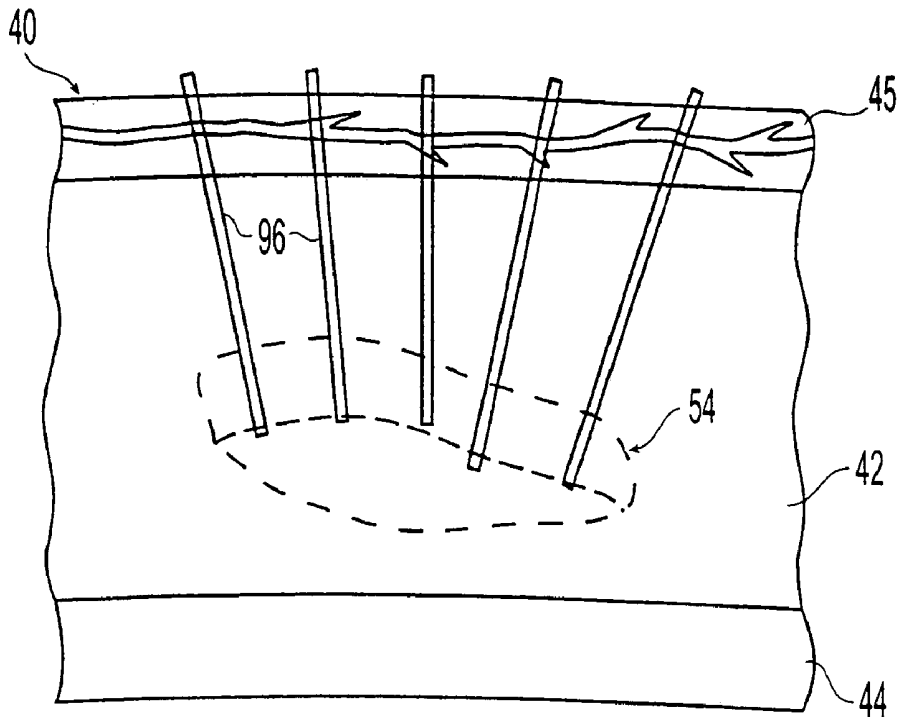

Fig. 5C

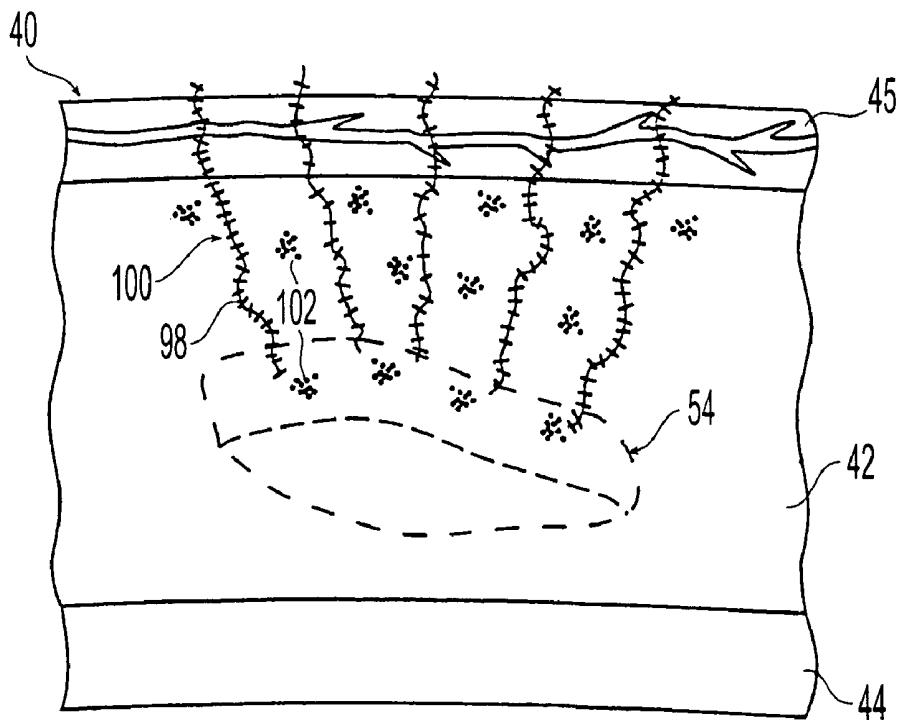

Fig. 5D

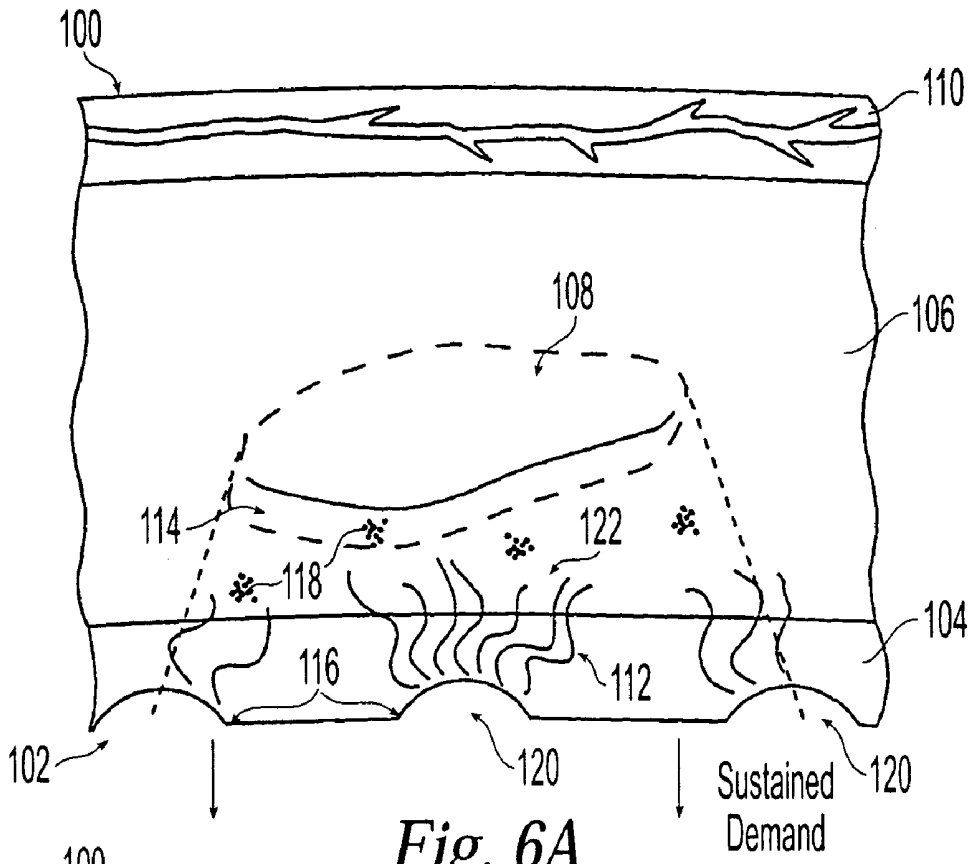

Fig. 6A

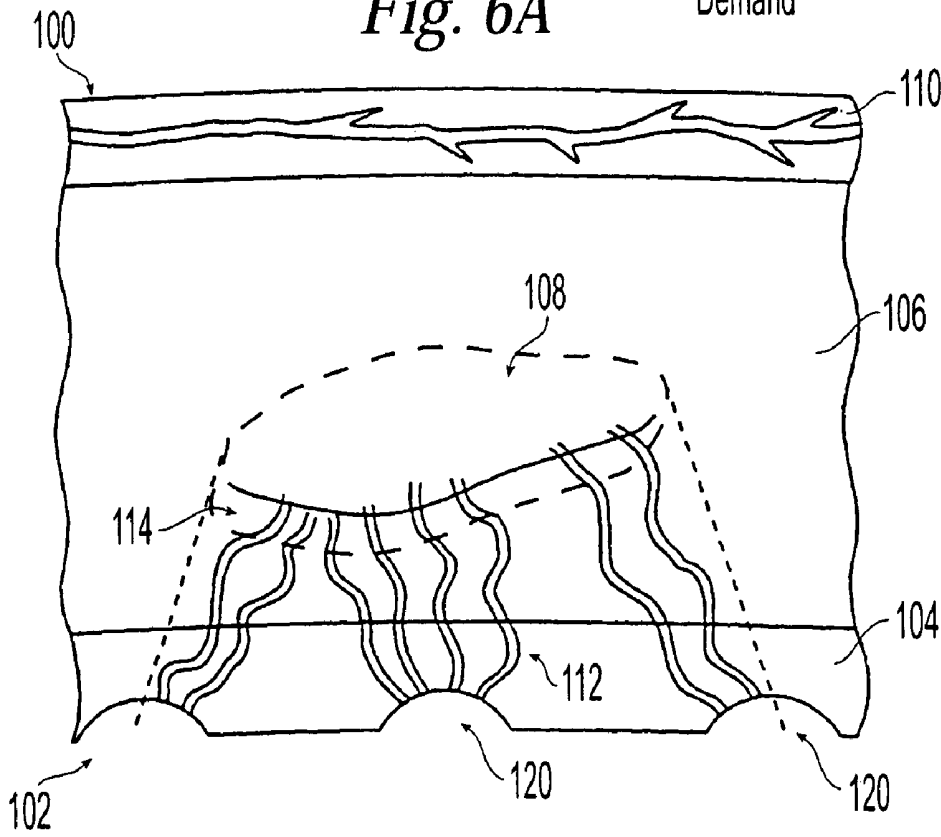

Fig. 6B

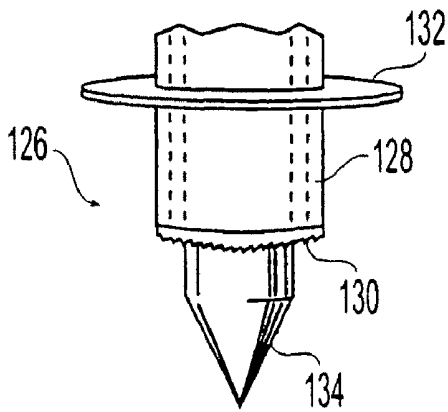

Fig. 7A

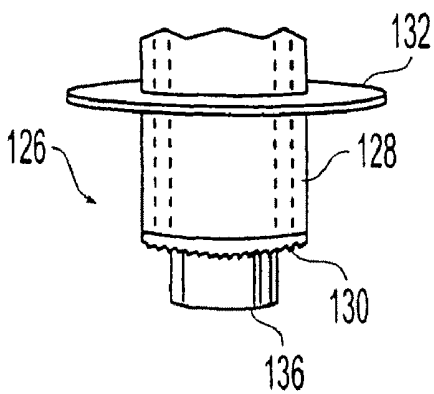

Fig. 7B

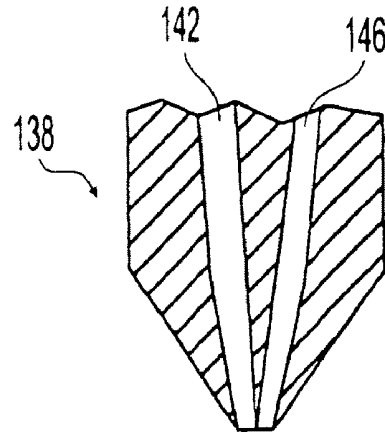

Fig. 8A

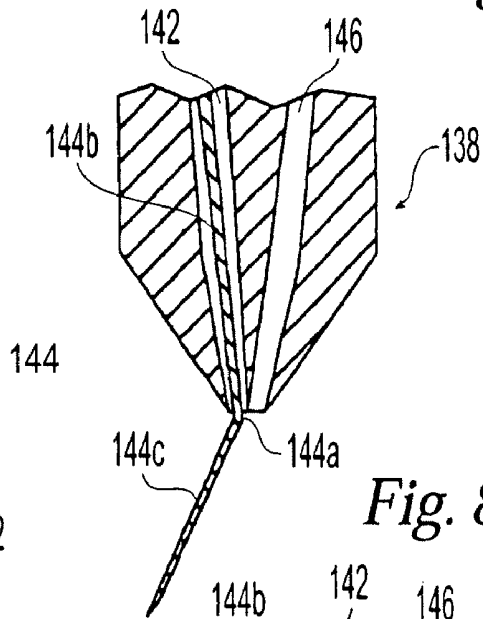

Fig. 8B

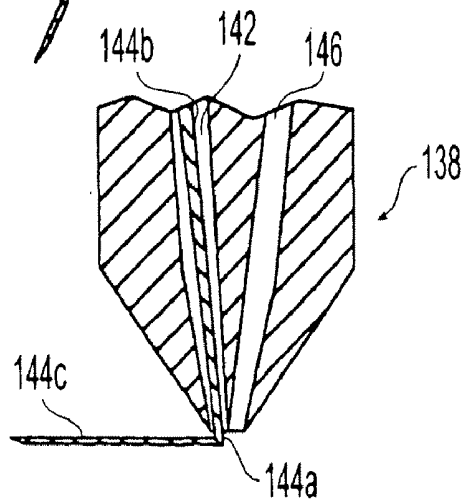

Fig. 8C

144

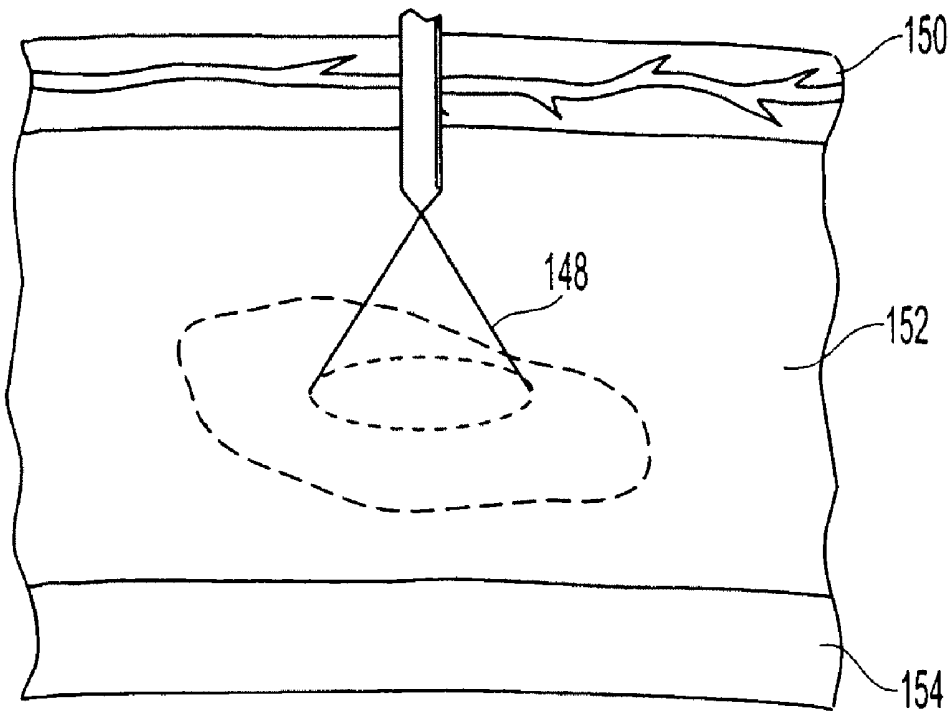

Fig. 9A

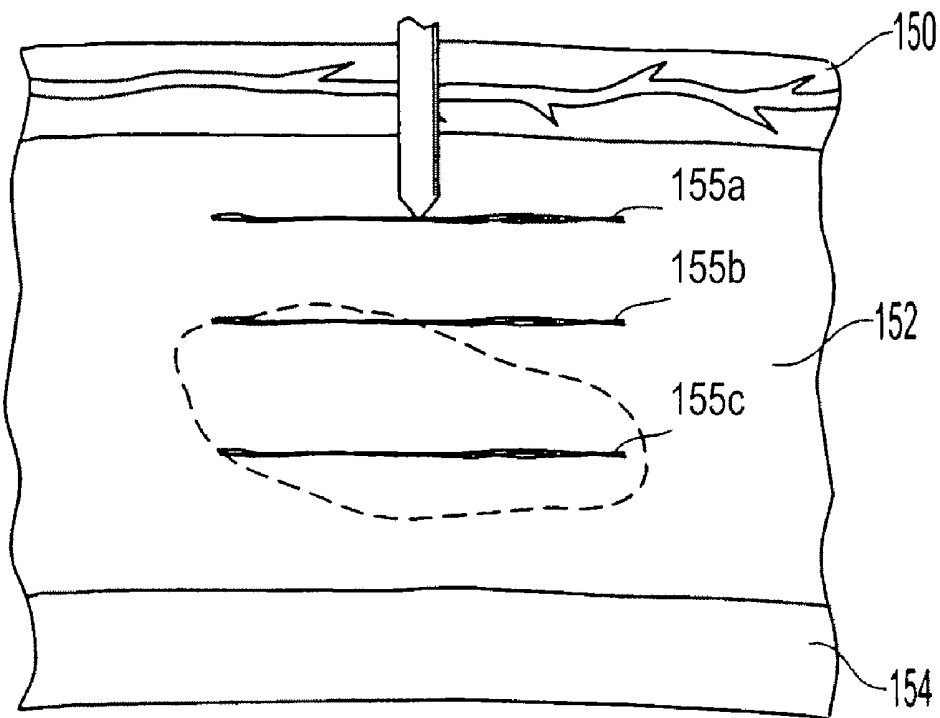

Fig. 9B

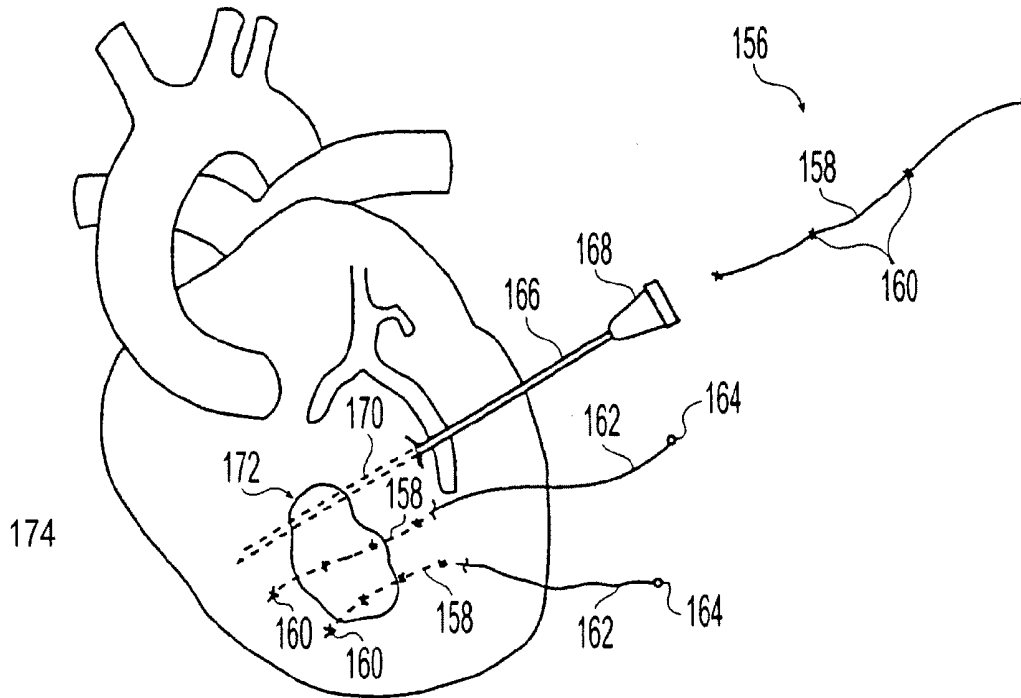

Fig. 10

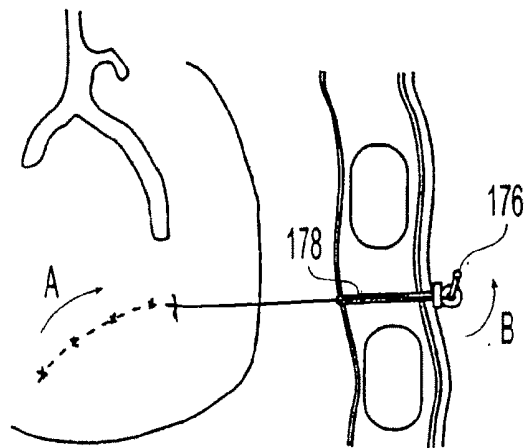

Fig. 11

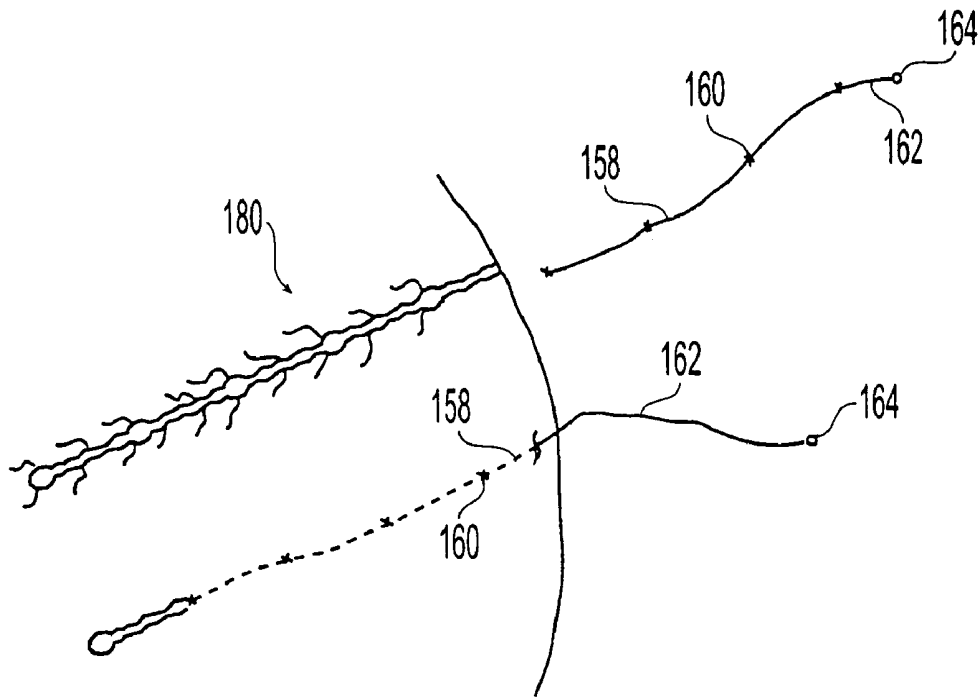

Fig. 12

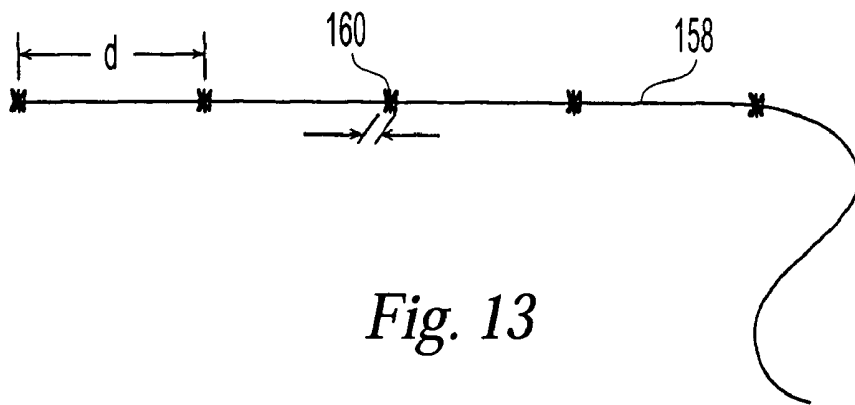

Fig. 13

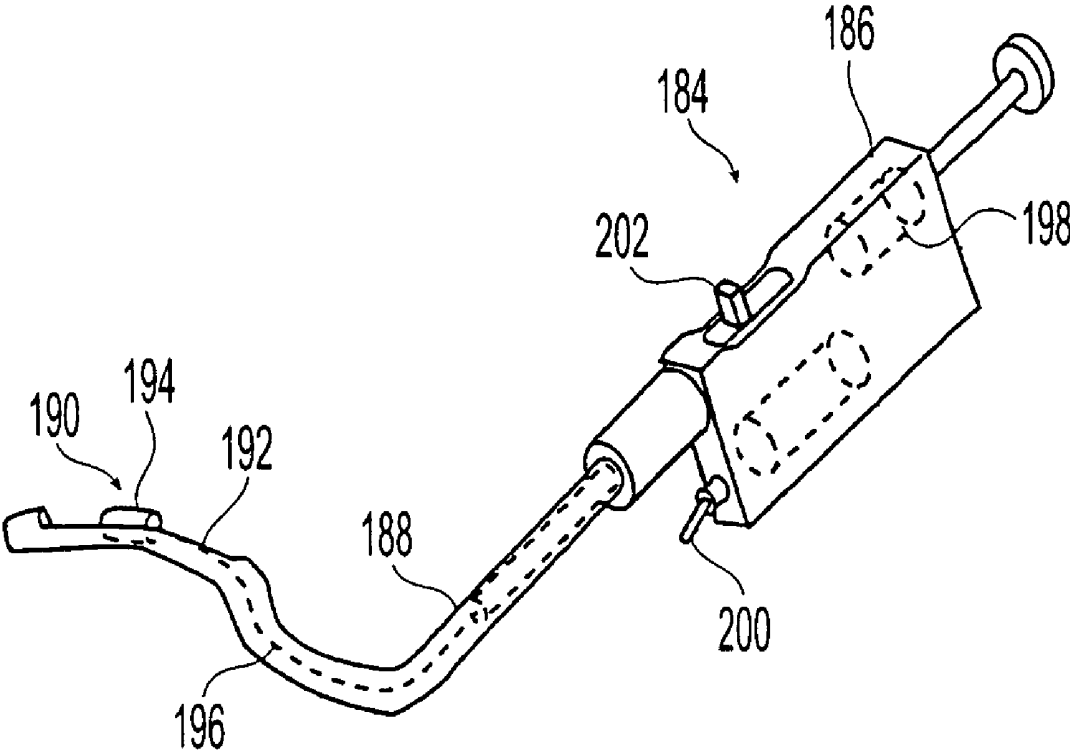

Fig. 14

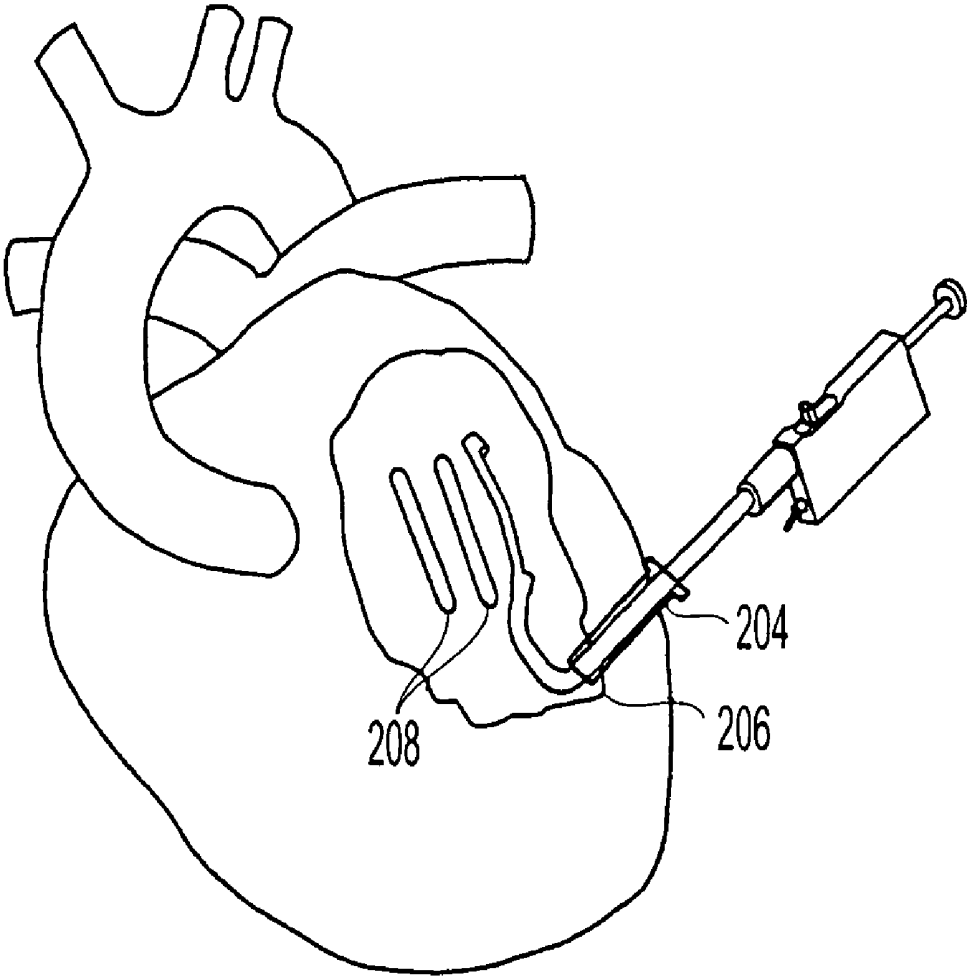

Fig. 15

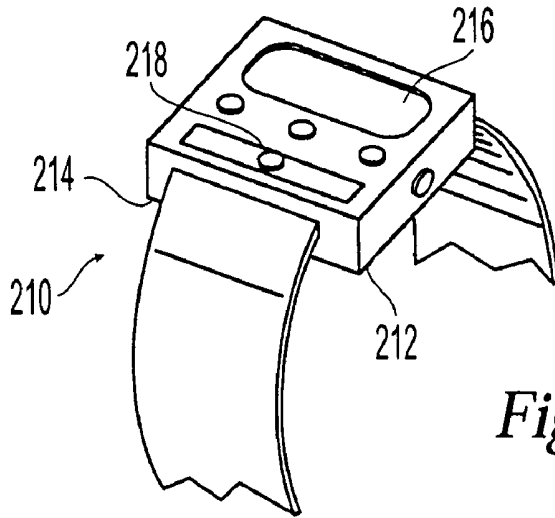

Fig. 16

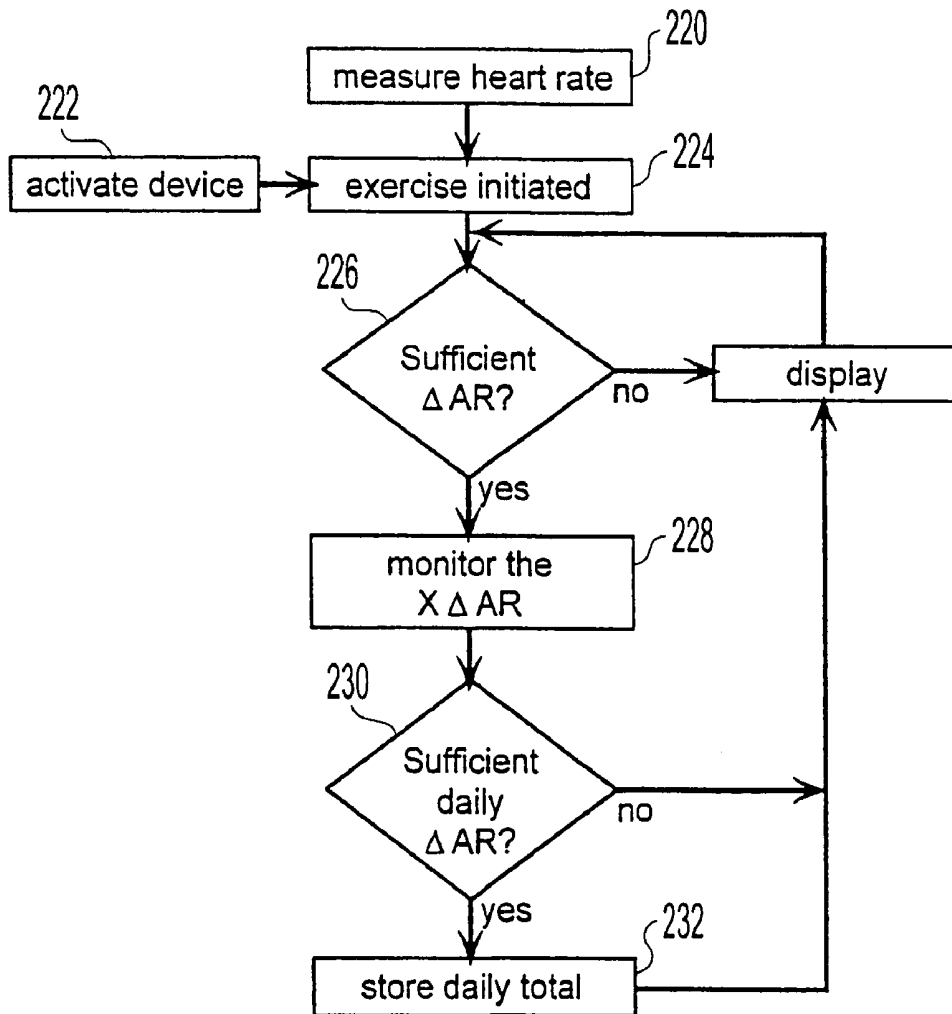

Fig. 17

METHOD FOR TREATING A PATIENT AT RISK OF LOSS OF CARDIAC FUNCTION BY CARDIAC ISCHEMIA

This application claims priority to U.S. Provisional Application Ser. No. 60/163,698 filed on Nov. 5, 1999, expressly incorporated by reference. This application is a divisional application of U.S. application Ser. No. 09/706,584 filed on Nov. 3, 2000, now U.S. Pat. No. 6,748,258, expressly incorporated by reference.

FIELD OF THE INVENTION

The present invention relates to methods and devices for treating a patient at risk of loss of cardiac function by cardiac ischemia.

BACKGROUND OF THE INVENTION

Heart disorders are a common cause of death in developed countries. They also impair the quality of life of millions of people and restrict activity by causing pain, breathlessness, fatigue, fainting spells and anxiety. The major cause of heart disease in developed countries is impaired or inadequate blood supply. The coronary arteries may become narrowed due to arteriosclerosis and part of the heart muscle is deprived of oxygen and other nutrients. The resulting ischemia or blockage can lead to angina pectoris, a pain in the chest, arms or jaw due to lack of oxygen to the heart's myocardium, infarction or tissue necrosis in myocardial tissue. Alternatively, and particularly with age, the extent of vascularization of the heart may diminish, leaving the heart undersupplied with oxygen even in the absence of significant arteriosclerosis.

Coronary-artery blockage can be relieved in a number of ways. Drug therapy, including nitrates, beta-blockers, and peripheral vasodilator drugs (to dilate the arteries) or thrombolytic drugs (to dissolve clots) can be very effective. If drug treatment fails, transluminal angioplasty is often indicated—the narrowed part of the artery, clogged with atherosclerotic plaque or other deposits, can be stretched apart by passing a balloon to the site and gently inflating it a certain degree. In the event drug therapy is ineffective or angioplasty is too risky (introduction of a balloon in an occluded artery can cause portions of the arteriosclerotic material to become dislodged which may cause a total blockage—at a point downstream of the subject occlusion, thereby requiring emergency procedures), the procedure known as coronary artery bypass grafting (CABG) is the most common and successful major heart operation performed, with over 500,000 procedures done annually in America alone. A length of vein is removed from another part of the body. The section of vein is first sewn to the aorta and then sewn onto a coronary artery at a place such that oxygenated blood can flow directly into the heart. CABG typically is performed in an open chest surgical procedure, although recent advances suggest minimally invasive surgery (MIS) techniques may also be used.

Another method of improving myocardial blood supply is called transmyocardial revascularization (TMR), the creation of channels from the epicardial to the endocardial portions of the heart. Initially, the procedure used needles to perform "myocardial acupuncture," and has been experimented with at least as early as the 1930s and used clinically since the 1960s, see Deckelbaum, L. I., *Cardiovascular Applications of Laser Technology, Lasers in Surgery and Medicine* 15:315-341 (1994). This procedure has been likened to transforming the human heart into one resembling that of a reptile. In the

reptile heart, perfusion occurs via communicating channels between the left ventricle and the coronary arteries. Frazier, O. H., *Myocardial Revascularization with Laser—Preliminary Findings*, *Circulation*, 1995; 92 [suppl 11:11-58-11-65]. There is evidence of these communicating channels in the developing human embryo. In the human heart, myocardial microanatomy involves the presence of myocardial sinusoids. These sinusoidal communications vary in size and structure, but represent a network of direct arterial-luminal, arterial-arterial, arterial-venous, and venous-luminal connections. The needle technique was not continued because the channels did not remain open, replaced by the use of laser energy to accomplish TMR.

Drug therapies with angiogenic growth factors may expedite and/or augment collateral artery development. To accomplish these needs, drug transfer devices for delivering precise amounts of these drugs can enhance this healing process. Surgeons who deal with minimally invasive surgical techniques and interventional cardiologists who deal with percutaneous approaches, need devices for drug delivery procedures. The drugs used in modern medical technology are often quite expensive, potentially mixing and/or handling sensitive, and it is a new challenge to make these drugs or other compounds readily available for precise, predetermined delivery during these advanced or other procedures.

SUMMARY OF THE INVENTION

The invention includes, in one aspect, a method of treating a patient at risk of loss of cardiac function by cardiac ischemia. The method is practiced by FIR imaging the patient's heart, or a portion thereof, to identify (i) an underperfused region of cardiac muscle, (ii) a source of oxygenated blood that is proximate a boundary of the underperfused region, and (iii) a target area that includes the underperfused region boundary and a tissue expanse lying between the oxygenated blood supply and the boundary. A stimulus effective to stimulate angiogenesis in myocardial tissue and form a capillary network from the source of oxygenated blood in the direction of the underperfused region is introduced at each of a plurality of sites throughout the target area. The demand for oxygen the underperfused region is then sustained for a period sufficient to convert the capillary network into an arteriole network.

The underperfused region is an at risk region of cardiac muscle which is insufficiently perfused to handle heightened activity or is likely to be near term at risk of underperfusion due to the progression of nearby disease and cannot be treated by the full restoration of normal coronary flow.

Usually, patients will enter this treatment regimen by appearing for intermittent angina (intermittent identifies that demand for arterial growth and arterial maturation is not reliably turned on) through drug or exercise stress testing where cardiac reserve appears less than optimal or when a routine treatment such as bypass, angioplasty or stents is unable to restore normalized blood flow, and in the judgment of the cardiologist or surgeon is at risk due to lack of reserve capacity. The imaging step to identify the area at risk and nearby source of oxygenated blood (target) may be carried out by monitoring blood flow in the heart by myocardial perfusion imaging by single-photon emission computed tomography (SPECT), positron-emission tomography (PET), echo-planar imaging, MRI, or angiogram.

The source of oxygenated blood in the method may be one in which arteries less than about 1 mm branch into surrounding arterioles, and in which the arterioles with inner-lumen diameters between about 50-200 microns are plentiful, and

the sites are spaced from one another at spacing of between 0.5 to 1 cm. Alternatively, or in addition, the underperfused region may be a myocardial region of either of the patient's ventricles, and the source of oxygenated blood, the interior of the underperfused heart ventricle region. Here the target area

The stimulus introduced at each of the target-area sites may be a growth factor, such as basic or acidic fibroblast growth factor-1 (FGF-2, FGF-1), vascular endothelial growth factor (VEGF), platelet-derived growth factor (PDGF), insulin-like growth factor-1 (IGF-1), or combinations of two or more of these growth factors. The growth factor may be introduced in the form of a recombinant protein carried in a pharmaceutically acceptable medium, a vector containing the coding sequence for the growth factor and a control region effective to promote transcription of the coding region in patient myocardial cells, and/or in the form of a myocardial or cardiac myoblast cells which have been transformed with a gene encoding the growth factor. The manner of introducing the growth factor may be by (i) injecting the protein, vector of cells directly into myocardial tissue at each site, (ii) drawing the protein or vector into myocardial tissue at each site by iontophoresis from a reservoir placed against the site, (iii) forming a channel in the myocardium at each site, and placing the protein, vector or cells into the channel, or (iv) bombarding each site with a biolistic particle containing or coated with the protein, vector or cells. For example, an angiogenic stimulus would be used without adjunctive biological triggering when the target area is predetermined at the patient evaluation and diagnosis stage to have sufficient pre-existing tissue demand for oxygen in the form of significant angina (Canadian Heart Class 4) or when the physician has predetermined that the patient can exercise post treatment to provide dependable tissue demand for arteriole growth beyond the pre-existing patient reserve capacity.

In another general embodiment, the stimulus, or biologic trigger, introduced into the target-area sites is an injury produced by a mechanical, laser, chemical, thermal, or ultrasonic stimulus. This type of stimulus may be additive to the effect of a drug stimulus by turning on the local naturally occurring angiogenic processes of adding a biologic trigger a new immediate tissue demand for oxygen is added which can be effectively used where Class 4 Angina is not available and exercise cannot be used due to related concerns. For example, the injury may be produced by a mechanical cutting device effective to produce an annulus of injury about a core of healthy cells. Alternatively, injury may be produced by introducing into each of the sites, a wire device having a barbed segment, where the method further includes periodically moving the wire devices relative to the heart, to produce a prolonged angiogenic stimulus at the site. In another example the stimulus may include a mechanical injury produced by forming, at selected target sites in the target area, elongate channels in the endocardium of the ventricle to stimulate angiogenic growth from the ventricle to neighboring target regions as described above. The depth and width of the endocardial channels, combined with the blood turbulence produced within the ventricle, is such as to minimize accumulation of blood clot material in the channels. The channels have preferred width and depth dimensions between 1-5 mm. This embodiment of the method may further include imaging the heart to identify (i) as a second source of oxygenated blood, coronary arterioles in the epicardial region of the ventricle overlying the underperfused heart-ventricle region, (ii) as a second target area the area between the second source of oxygenated blood supply and the underperfused region, and

the adjacent boundary of the underperfused region. There is then introduced into the second target area, at selected sites therein, a stimulus effective to stimulate angiogenesis in the target area. Sustained demand can also be created with chemical methods such as acidic injections, with implants that elicit a foreign body response, and with viral carriers which might be used to facilitate angiogenic gene transfer.

The sustained demand may be by requiring the patient to adhere to an exercise regimen, or by producing a recurrent or slow-healing injury at or near the target-area sites. For example, sustaining the demand may include the additional steps, after initially inducing capillary blush, of equipping the patient with an exercise monitor that indicates the level and amount of heart exercise the patient achieves, and requiring the patient to achieve an amount and level of heart exercise effective to stimulate the conversion of capillary blush produced by the introducing step to arterioles in the target area. The exercise regimen is carried out over a period of at least weeks 4-15 following the introduction of angiogenic stimuli.

These and other features of the invention will become more fully apparent when the following detailed description of the invention is read in conjunction with the accompanying drawings.

BRIEF DESCRIPTION OF THE DRAWINGS

FIG. 1 is a simplified view of a human heart;

FIGS. 2A and 2B show cross-sectional (2A) and plan (2B) views of a ventricle wall a human heart, in an underperfused region of the wall, and corresponding generally to the region of line 2-2 in FIG. 1;

FIGS. 3A and 3B illustrate the development of capillary blush in an underperfused region of a heart ventricle wall (3A) and subsequent development of arterioles with sustained demand (3B), where the source of blood supply is a coronary arterial supply;

FIGS. 4A and 4B illustrate the distribution of growth-factor stimulus introduced in a target area of an underperfused region of a heart for achieving substantially uniform distribution of a growth factor (4A), and for achieving a higher short-term growth factor effect close to the blood supply, and a longer-term growth-factor effect close to the underperfused region;

FIGS. 5A-5D illustrate various methods of producing an injury stimulus to a target-area of adjacent an underperfused heart region, including a mechanical "coring" injury (5A), a mechanical wire injury (5B), a laser-induced channel injury (5C), and a combination of a mechanical wire injury and growth factor stimuli;

FIGS. 6A and 6B illustrate the development of capillary blush in an underperfused region of a heart ventricle wall (6A) and subsequent development of arterioles that occurs with sustained demand (6B); where the source of blood supply is the interior chamber of the heart left ventricle;

FIGS. 7A and 7B illustrate coring tools constructed in accordance with embodiments of the invention;

FIGS. 8A-8C illustrate various states of a coring/drug-delivery tool constructed in accordance with another embodiment of the invention;

FIGS. 9A and 9B illustrate different types of myocardial-slice injuries producible by the coring/drug-delivery tool of FIGS. 8A-8C;

FIG. 10 illustrates how a wire tool is introduced into a target-area site in the heart, in accordance with one embodiment of the invention;

FIG. 11 shows how the wire tool can be controlled from an external chest site;

FIG. 12 illustrates the mechanics of vascularization that is produced by a sustained-injury from the FIG. 10 tool;

FIG. 13 shows details of a portion of the wire tool in FIG. 10;

FIG. 14 is a perspective view of a cutting tool constructed according to one embodiment of the invention;

FIG. 15 illustrates the placement of the tool of FIG. 14 in producing a channel injury to a ventricle endocardial wall surface;

FIG. 16 shows an exercise monitoring device for use in monitoring and tracking heart-rate exercise, in creating a sustained demand to an underperfused region of the heart; and

FIG. 17 illustrates the operation of the exercise-monitoring tool in FIG. 16.

DETAILED DESCRIPTION OF THE DRAWINGS

Treatment Method

FIG. 1 is a simplified view of a human heart 20. The interior of the heart is divided into right and left halves by a thick central muscular wall 22 known as a septum. On the right side, the upper chamber is known as the right atrium, indicated at 24. Deoxygenated blood from the rest of the body arrives in the right atrium via the vena cava, and is pumped across a one-way valve 28 known as the tricuspid valve into the lower right chamber known as the right ventricle, indicated at 30. From there the blood circulates to the lungs through the pulmonary valve via the pulmonary artery where it is oxygenated by circulation through the alveoli of the lungs (not shown). The blood returns via the pulmonary veins to the left atrium, shown at 34 and flows through a second valve, known as the mitral valve, into the left ventricle, indicated at 38, where it is pumped via the aorta 32 to the rest of the body.

With reference to FIGS. 2A and 2B, which show a wall portion 40 of the heart left ventricle corresponding to view line 2-2 in FIG. 1, much of the heart consists of a special type of muscle called myocardium, indicated at 42. The myocardium requires a constant supply of oxygen and nutrients to allow it to contract and pump blood throughout the vasculature. The inner surfaces of the chambers of the heart are lined with a smooth membrane 44, the endocardium, and the entire heart is enclosed in a tough, membranous bag 46, known as the pericardium or pericardial sac.

Though the heart supplies blood to all other parts of the body, the heart itself has relatively little communication with the oxygenated blood supply. Thus, the two coronary arteries, the left coronary artery and the right coronary artery, arise from the aorta and encircle the heart muscle on either side “like a crown” to supply the heart itself with blood. Coronary arteries are shown at 48 in FIGS. 2A and 2B, and the arterioles branching from these arteries, at 50. The arteries and arterioles are largely confined to the epicardium 45 and adjacent regions of the myocardium. The arterioles, in turn, feed a capillary bed within the three heart-wall layers. A venous capillary system in the same layers returns blood from the coronary arteries to the coronary veins, the coronary sinus, and the right atrium.

Supply-and-Demand Model

The present invention provides methods and devices for treating a patient at risk of loss of cardiac function by cardiac ischemia. The methods are designed to increase blood flow or circulation from a source of oxygenated blood in the heart to a region that is underperfused—that is, a region that is receiving less oxygenated blood than that optimally required by the heart under a moderate load or stress. As a consequence of this underperfusion, or ischemia, the patient is at risk of, or has already suffered some loss of, cardiac muscle used in normal

heart functioning. If the patient at risk has already suffered some loss of heart muscle, the region of lost muscle is referred to as a nonviable muscle, indicative of a cardiac infarction.

In practicing the treatment method, one first images the patient’s heart, to identify (i) an underperfused region of cardiac muscle, (ii) a source of oxygenated blood that is proximate a boundary of the underperfused region, and (iii) a target area that includes the underperfused-region boundary and a tissue expanse lying between the oxygenated blood supply and said boundary. The imaging may also be used to identify (iv) the degree or magnitude of high grade tissue demand for oxygenated blood that is naturally occurring in the underperfused region and based on this assessment if a biological trigger will be added.

The imaging step is illustrated in FIGS. 2A and 2B, illustrating a portion of a heart ventricle wall 40 as described above. The figures show an underperfused region 54 in the myocardium of a ventricle wall. The underperfused region contains at least some viable, but hibernating muscle (i) whose functioning can be improved by increased blood supply to the region, and/or (ii) which is at high risk of suffering future injury due to the advanced state and expected progression of disease (iii) which in the physician’s judgment is not ideal for an expected safe full normal blood flow restoration procedure such as balloon angioplasty. It is possible that some portions of the underperfused region will contain non-viable cells for which improved blood supply will not affect the cell status.

The underperfused region is preferably identified in lateral surface dimensions, and to the extent possible, in sectional dimension, to produce a lateral or volumetric image of the underperfused regions.

The source of oxygenated blood will typically be the arterial supply of blood localized in the pericardial, epicardial and outer myocardial layers of the heart, adjacent the underperfused region. Ideally, the source will be one in which an area of dense arteries less than about 1 mm branch into surrounding arterioles, and in which the arterioles with inner-lumen diameters between about 50-200 microns are plentiful. FIGS. 2A and 2B illustrate an artery 48 branching into arterioles 50 that form a suitable source of oxygenated blood.

In another embodiment of the invention, discussed below, the source of oxygenated blood is the interior of a ventricle chamber, where the method is practiced in a manner to promote blood supply between the interior of the chamber, across the endocardium, to the myocardial layer.

The oxygenated blood supply that is identified is proximate to a boundary or boundary portion 56 (FIG. 2A) of the underperfused region. This boundary represents the initial portion of the underperfused region which will receive increased blood supply as a vascular network from the blood supply to the underperfused region is formed. In the drawing, the boundary represents the 20-40% of the total underperfused region that is closest to the identified supply of oxygenated blood. Although more of the region may be included in the boundary, there may be little gain in increased vascularization of the underperfused region, until the boundary region itself can be initially vascularized, assuring sufficient blood cells in reserve for later new growth distribution. Thus, the method may involve an initial treatment to vascularize the boundary of the underperfused region, and subsequently using the new vascular supply as the source of oxygenated blood for extending the vascular network deeper into the underperfused region, that is, into the region below the initial boundary portion shown in FIG. 2A.

The area between the identified source of oxygenated blood and the underperfused region, including the boundary

portion of the underperfused region, and the tissue expanse **58** between the underperfused region and the source of oxygenated blood, is identified from the imaging step as a target area **60** (typically a volumetric region) at which the stimulus for angiogenesis is to be introduced, as will be described. Within this target area, the user will identify a plurality of sites, such as indicated at **62**, at which a stimulus will be applied. The sites in the target area have a preferred site-to-site spacing of between about 0.5 to 1 cm.

A variety of tools are available for imaging the heart, and localizing regions of subnormal blood circulation. One such tool involves monitoring blood flow in the heart by myocardial perfusion imaging (MPI) by single-photon emission computed tomography (SPECT) positron-emission tomography (PET), echoplanar imaging or angiography. These techniques are described in the literature (e.g., Amanullah, Mannting, Golub, Hansen, Toma, Dietlein, Sand, Marwick, Yang, Inuoe, and Nishimura).

Alternatively, or in addition, the patient's heart can be imaged by magnetic resonance imaging (MRI), including myocardial perfusion imaging by dynamic contrast MRI. Pertinent methods have been detailed in the literature (e.g., Furber, Lauerma, and Sechtem). Thallium scintigraphy is yet another imaging method technique available (e.g., Mache-court).

In addition an assessment is made to determine the pre-existing level of tissue demand for oxygenated blood. The heart has naturally occurring angiogenesis when disease progression occurs slowly so the high stress/exercise demand periods requiring blood flow do not exceed the compromised supply. By way of example a Class 4 Angina (measure of chest pain and class 4 is usually indicative of near constant pain) would be a good indicator of high level demand for new capillary growth. When high grade angina is not present patients will typically receive an exercise or chemical stress test where cardiac reserve can be quantified. Physicians may also use their own predictive skills when finding a high grade, non-symptomatic untreatable distal coronary artery blockage. When high grade demand is not present it can be added by using a biologic trigger as described herein. When general health permits demand can be increased with exercise.

Once the target-area and sites within this area have been identified, a stimulus effective to stimulate angiogenesis in the myocardial tissue from the source of the oxygenated blood to the underperfused region is introduced at each of the target sites. As will be discussed in detail below, the stimulus may be an angiogenic growth factor that is introduced either as a growth-factor protein, a vector capable of transfecting myocardial cells to produce the desired protein growth factor, or cells which have been transfected in vitro to contain the desired growth factor. Alternatively, the stimulus may be a biological trigger, such as a tissue injury produced by a mechanical, laser, electrical, radio frequency, chemical, thermal, or ultrasonic injury. The stimuli introduced may be in the form of a combination of growth factor and injury.

FIGS. 3A and 3B illustrate the supply/demand model of vascularization on which the present method is based. The model has four components: (i) a supply or source of oxygenated blood; (ii) a localized underperfused region which represents a demand for increased oxygenation, (iii) localized stimuli applied to a target area between the source of blood and underperfused region, to induce a capillary blush in the target area, and (iv) a sustained demand for oxygen in the underperfused region which is effective to convert the capillary blush to a stable and effective arteriole vasculature supplying the underperfused region from the source of oxygenated blood.

The initial angiogenic event is a capillary blush, such as indicated at **64** in FIG. 3A. This blush is made up of a fine network of capillaries, and typically is formed within 3-15 days after the initial angiogenic stimulus. The formation of the initial capillary blush requires a poor supply of oxygenated blood, and an angiogenic stimulus, but not necessarily a demand for increased vascularization. Without a sustained demand, or without a continuous introduction of stimulus, the capillary blush will begin to fade within several weeks, and eventually the heart will return to its pre-treatment conditions.

In accordance with the invention, an effective, and long-term vascular network from the source of oxygenated blood to the underperfused region is created by maintaining a sustained oxygen demand (or creating conditions of a natural sustained demand), until the capillary blush matures into a network of arterioles, such as indicated at **66** in FIG. 3B, which are supplied by the source of oxygenated blood, and which extend into the target area, to supply oxygenated blood to the previously underperfused region.

Thus, the treatment method has three key features: (i) the identification of a target site between an area of oxygenated blood supply and an underperfused region, (ii) the introduction of angiogenic stimuli in this area, to create a capillary blush in the area, and (iii) conditions of a sustained demand, produced either naturally or artificially, that cause the capillary blush to develop into a mature vasculature between the areas of supply and demand.

Stimulating Angiogenesis by Growth Factor

In one general embodiment of the invention, the stimulus introduced into the target-area sites is a growth factor effective to induce angiogenesis in the myocardial sites where it is introduced, including area surrounding the sites. Exemplary growth factors include basic and acidic fibroblast growth factor (FGF-2 and FGF-1, respectively), vascular endothelial growth factor (VEGF), platelet derived growth factor (PDGF), insulin-like growth factor-1 (IGF-1), angiopoietin-1, angiopoietin-2, and combinations of two or more of these growth factors, including as angiopoietin-1 in combination with VEGF. Typical growth-factor doses, such as those given for VEGF (Murayama) or FGF-2 (Hasegawa), can be found in the literature. The growth factor introduced may be in the form of (a) a protein, typically made by recombinant methods, (b) a vector containing the coding region for the growth factor under the control of suitable human regulatory elements, or (c) myocardial cells which have been transfected in vitro to express the selected growth factor. Alternatively, the growth factor may be introduced through special cells, such as bone-marrow-derived endothelial progenitor cells (EPCs), that may contribute to neovascularization, introduced either alone or in combination with growth factors, such as VEGF, known to mobilize EPCs.

The growth factor may be introduced by a variety of means including (i) injecting the protein, vector, or transformed myocardial cells directly into myocardial tissue at each target-area site, (ii) drawing the protein or vector into myocardial tissue at each site by iontophoresis from a reservoir placed against the site, (iii) forming a channel in the myocardium at each site, and placing the protein, vector or cells into the channel, and (iv) bombarding each site with a biolistic particle containing or coated with the protein, vector or cells.

Methods for injecting pharmaceutical agents into myocardial tissue are known in the art, e.g., as detailed U.S. Pat. Nos. 5,685,853 and 5,661,133. One preferred device is the drug-delivery module disclosed in U.S. patent application Ser. No. 09/080,892, filed Sep. 24 1998, which is incorporated herein by reference. Briefly, this device allows successive regulated

introduction of a metered amount of a drug agent into a cardiac site, for example, as an attachment to an endoscope. The drug-delivery device may also be equipped with a sensing device, such as the ultrasound device disclosed in U.S. patent application Ser. No. 08/852,977, filed May 7, 1997, also incorporated herein by reference, which provides the user with information about the distance of the injection head from the surface of the heart.

Iontophoretic administration of a growth factor protein or vector may be carried out by placing embedding the protein in a porous electrode, placing the electrode against the pericardial wall corresponding to one of the target sites, and applying a current across the electrode. The counter-electrode may be any attached to any external site on the patient.

A variety of tools are available for forming transmural channels, e.g., by laser ablation, ultrasound, mechanical means, or the like, and these tools may be combined with suitable delivery tools for introducing into the channels, the selected protein, vector, or transformed cells. One suitable drug delivery device that employs laser ablation for drug delivery is disclosed in U.S. Pat. No. 5,925,012, which is incorporated herein by reference.

For biolistic introduction of growth-factor protein, vectors or transformed cells are known, the agent to be delivered is introduced into a high-pressure stream of fluid, e.g., air or water, and directed against the pericardial surface of the heart. Alternatively, the device may be designed to puncture the pericardium, and introduce the material in a high-pressure stream directly into the myocardial layer.

Methods for producing human growth factors are known, e.g., by recombinant production are known, as are vectors suitable for transforming human cells to achieve expression of selected growth factors. Myocardial cells transformed in vitro with angiogenic growth factors, and injected into myocardial tissue have also been reported.

The growth factor may be introduced in free, that is, solution or suspension form, encapsulated within suitable carriers, such as liposomes or biodegradable particles. Gold particles suitable for biolistics, are well known, as are methods for introducing projectile particles into tissue.

The introducing step may be carried out in a manner that achieves a desired spatial or temporal pattern of growth factors at the target-area sites. The pattern shown in FIG. 4A is a uniform spatial and temporal pattern in which the growth factor is equally accessible at roughly equal concentrations at each site, such as site 70, where the drug in free form is represented by dots in the figure, and the sectional view is like that in FIGS. 2A, 3A and 3B, where similar numbers represent similar anatomical features. With this pattern, substantially each site with the target area is exposed over the same time period to the same concentration of growth factor. This pattern of growth factor results in a capillary blush that has a relatively short duration, e.g., a period of a few weeks, without a sustained demand for oxygen at the underperfused region.

The pattern of growth factor shown in FIG. 4B is designed to produce a temporal gradient of angiogenic factor that produces a relatively high, short-term concentration of the agent closest to the oxygen supply, where capillary blush is initiated, and a longer-term release of growth factor progressing toward the underperfused region. The temporal gradient is produced by introducing into the sites closest to the blood supply, such as sites 72, a freely usable form of growth factor, e.g., the growth factor protein in solution form. At sites intermediate the blood supply and underperfused region, such as sites 74, the growth factor is packaged in a controlled release form, such as in a biodegradable particle, or in a form of a

transforming vector, that functions to meter growth factor from the site over a relatively long period, e.g., 1-4 weeks. At sites close to or within the boundary of the underperfused region, such as indicated at 76, the growth factor is contained in an even slower-release form, e.g., for growth-factor release or production for a 1-3 month period or longer. This temporal distribution of growth factor allows for initial formation of capillary blush near the source of oxygenated blood supply, followed by angiogenesis at progressively deeper levels in the myocardium.

Stimulating Angiogenesis by Injury

In another general embodiment of the treatment method, the angiogenic stimulus is provided by a biologic trigger, an injury to the myocardial tissue, either alone or in combination with an angiogenic growth factor. Heart-muscle injury is known to produce a sequence of biochemical responses that ultimately lead to angiogenesis. This sequence generally involves a hypoxic condition following injury, leading to build up of lactic acid in the injured area, which stimulates macrophage infiltration into the injury site, stimulation of angiogenic factors by the macrophages and, in response to the growth factors, epithelial cell proliferation leading to capillary formation.

One feature of injury as an angiogenic stimulus is that the injury may also contribute to the sustained demand for oxygen necessary for stable vasculature development in the target area and underperfused region. That is, until the injury is resolved, the body will attempt to supply the injury area with increased blood supply as part of the response to injury. The ideal injury is a recurrent injury, and/or one slow to resolve, but at the same time, is resolved with a minimum of scarring, which is the body's way of resolving an area of cells destroyed by the injury and where the degree of surrounding inflammatory and angiogenic effect is maximized or complements the co-delivered angiogenic compound. For example a more thermal injury is slower healing and might complement a time release gel-based angiogenic drug co-placement, while a more abrasive/inflammatory injury might complement a short lived gene or protein construct.

FIGS. 5A-5D illustrates several types of injuries suitable as angiogenic stimuli in the present invention. In each of these cross-sectional figures, anatomical features corresponding to those described in FIGS. 2A, 3A and 3B have the same figure numbers as in those figures. The injury illustrated in FIG. 5A is a novel coring injury, such as injury 80, that results in a core or island 82 of healthy cells surrounded by an annulus 84 of injured cells at each target-area site, such as site 86. The injury is made in a way that leaves a relatively narrow channel injury 87, in the epicardium, about 2-3 mm in depth, and the annular injury about 2-3 mm in depth in the myocardial layer, at the target site 86. The core injury minimizes the total amount of destroyed cells in the myocardium, while leaving a large injury area that will become vascularized, both within, and outside the core, and an injury that may be relatively slow to resolve. The coring injury can also be made from the ventricle starting at the endocardium. Additional details of a coring device used to produce such an injury and its method of use are given below.

FIG. 5B illustrates a mechanical injury produced by a wire device, such as device 88. The wire device, which is described in greater detail in Section III below, includes a wire 90 having a series of barbs or cutters, such as barbs 92, along its length. Although not shown here, the device may have a proximal-end thread by which the device can be extracted from a remote, e.g., external body site. To produce the initial angiogenic stimuli, a wire device is inserted at each preselected target-area site 94 in the heart. As the heart tissue

attempt to resolve the injury, an initial capillary blush develops in the target area. At periodic intervals after wire placement at the sites, e.g., typically at intervals of hours or days with longer intervals possible using smaller devices and anti-fibrotic coatings, the wire may be partially extracted, preferably from a remote site, as discussed below. This pulling drags the wire barbs through the initial injury site, producing a recurrent injury that sustains the demand for oxygen within the target site, and thus promotes transformation of an initial capillary blush into a more stable arteriolar blood supply to the underperfused region. Over a period of several weeks or months, the wire devices will have been completely extracted from the heart, and are thereafter removed from the patients' body.

FIG. 5C illustrates an injury produced by an energy beam source, such as a laser beam. As illustrated, the beam produces channels, such as channels 96, of vaporized or otherwise destroyed cells that extend through the epicardium into the myocardium, and form the angiogenic sites in the target area. The channel thickness, which is larger than the laser-beam width, is typically about 1 mm; the channel depth ranges typically between about 4-8 mm, and extends either into or through the myocardial layer. Over time, the channel fills with clotted blood and it is ultimately resolved by vascularization in the target area, and scar formation in the channel areas. Apparatus for producing laser-channel injury to the heart, in a procedure known as transmural revascularization (TMR) is described for example, in U.S. Pat. Nos. 5,931,834 and 5,785,702. The present invention differs from known TMR methods in that the injury channels are placed selectively in a target-area preselected to bridge the region of myocardium between a supply of oxygenated blood and an underperfused region. This has the advantage over the prior art of maximizing the vascularization effect of the channels, while minimizing the number of channels, and thus extent of scarring injury to the heart needed to effectively revascularize an underperfused heart region.

In each of the injury methods outlined above, the injury can be combined with added growth-factor stimuli to augment or accelerate the development of the original capillary blush, or to augment the development of a mature vasculature in the target area. For example, in the channel injury illustrated in FIG. 5C, an angiogenic growth factor may be introduced into the channels, or introduced into separate sites in the target area. A combined injury/growth-factor stimuli is illustrated in FIG. 5D, which shows a target area having injury stimuli produced by wire devices, such as device 98 at preselected target-area sites, such as site 100, and sites of-growth-factor placement, such as site 102. The growth factors assist initial capillary blush, and the wire devices are manipulated, as above, to produce a recurrent-injury demand on the developing vasculature.

In a second general embodiment, the source of oxygenated blood flow for supplying an underperfused myocardial region is the interior of the heart's left or right ventricle walls. Normally, blood passing from the interior ventricle chambers into the myocardium supplies only about 20% of the oxygen needs of the heart, the other 80% being supplied coronary arteries surrounding the outside of the heart. In subjects having adequate oxygen supply to the heart muscles, the relatively non-porous endocardium, which limits blood flow from the ventricle chambers into the myocardium serves to hold blood dampen extremes of pressure occurring in the ventricles. However, in subjects with underperfused regions of myocardium, it would be useful to make localized wall

regions of the ventricle more porous, to allow direct blood supply from the ventricle interior to the adjacent undersupplied myocardium.

This is done, in accordance with this general embodiment, by using a biological trigger to produce an injury to the ventricle wall, adjacent the underperfused regions and/or by introducing growth factors at sites in a target area located between the underperfused regions and immediately "underlying" endocardium. The method is illustrated in FIGS. 6A and 6B which show a cross-sectional ventricle portion 100 of a heart, including a ventricle chamber 102, an inner endocardial layer 104, a myocardial layer 106 containing an underperfused region, 108, and an outer epicardial layer. The target area in the method is a region 112 between the inner wall of the ventricle chamber and the underperfused region, and includes a boundary 114 in the underperfused region adjacent the ventricle wall. In practicing the method, one identifies (i) target area by imaging, as above, and (ii) a plurality of target-area sites for introducing an angiogenic stimulus. The sites may be sites such as sites 116, on the inner ventricle wall, when the angiogenic stimulus is an injury to the inner wall, and/or sites, such as sites 118, within the ventricle wall, when the angiogenic stimulus is a growth factor. The growth factor is introduced at the preselected sites by one of the methods outlined above. The injury to the inner ventricle wall is preferably produced by a skiving or channeling tool, which produces elongate channels, such as channel 120 along the inner ventricle (endocardial) wall surface. The skiving tool and its application to the present method are detailed below.

FIG. 6A illustrates a network 122 of capillaries that make up the initial capillary blush in response to the injury and/or growth-factor stimuli. Over time, and with the continued stimulation provided by the channel injuries, this capillary blush will develop into a more stable blood-supply source to the underperfused region, either by forming more stable arterioles or through the maintenance of the oxygen demand by the injury.

The treatment method also contemplates treating an underperfused region of the heart by combining the treatment directed at the "outer" boundary of the region, as described with respect to FIGS. 2-5, with the treatment directed at the "inner" boundary of the heart, as described with respect to FIGS. 6A-B.

Sustaining Demand

As already noted, the treatment method requires continued demand for oxygen at the underperfused site to convert the initial capillary blush into a more stable and effective oxygen supply from the blood-supply source.

In one general embodiment, detailed below, the demand for oxygen is maintained by stressing the underperfused region by exercise. Briefly, the patient is equipped with an exercise monitor that indicates the level and amount of heart exercise the patient achieves. Typically, the patient should begin the exercise regimen within 3-8 days following the introduction of angiogenic stimuli to the heart. The patient is required to achieve a given exercise level for a period of at least 14 days, and preferably for a period of 2-3 months, following capillary blush formation. The amount and level of heart exercise is effective to stimulate the conversion of capillary blush produced by said step (b) to arterioles in the target area. The level can be readily derived from reviewing the result of a patient's baseline exercise stress testing, and developing a heart rate level and time which is both safe and challenging. The exercise monitor can provide the safety and record keeping necessary. A pacemaker may be temporarily or permanently added to exercise the heart.

In another general embodiment, the sustained demand is produced by a slow-healing or recurrent biological trigger, such as outlined above, and also considered in detail below. The demand for oxygenated blood created by the injury is sustained for a period of at least 2-3 months, following capillary blush formation.

Method and Device for Mechanical Coring Injury

FIGS. 7A-7B and 8A-8C illustrate various coring-injury-producing devices. These devices are designed to produce various types of coring injuries, such as an injury that defines a disk-shaped area or carves out a conical portion of injured cells at a target site surrounded by healthy cells. The core injury is preferably produced below the surface in the myocardial layer and in such a manner as to minimize the total number of destroyed cells in the myocardium, while leaving a relatively large injury area that will become vascularized and that may be relatively slow to resolve. Localization of such an injury requires a tool that has a means of entry into the tissue which is lower in trauma than the introduction of the injury itself which is preferably produced about 1-4 mm below the epicardial region in the underlying myocardial region.

One such cutting tool that may be used to produce a subsurface coring injury is shown in its distal portion at **126** in FIG. 7A. The tool has an elongate sleeve **128** which can be guided to a selected heart target-area site, and which terminates at its distal end in a cutting surface **130**. The sleeve carries a radially enlarged annulus **132** which limits the depth of penetration of the tool into the heart muscle.

Sleeve **128** accommodates a piercing element **134** which can be moved radially within the sleeve to project its piercing tip beyond the distal end of the sleeve. In operation, the piercing element is moved to such a position to function to pierce the epicardial layer when the tool is being introduced into the heart muscle, at a selected target-area site in the heart. Once the piercing tip has entered the myocardium, the sleeve may be advanced into the myocardium, with a cutting motion applied to the sleeve, to produce an annular cut through the myocardium tissue, typically about 2-3 mm into the myocardium.

To remove the tool from the heart, after the subsurface coring injury is made the sleeve is removed from the heart muscle, leaving a core injury of the type described in FIG. 5A above.

FIG. 7B shows a tool that can be used to make a surface coring injury. Here a blunt-end rod **136** is used instead of the piercing element **134**. This rod is pushed against the tissue core inside the sleeve as the sleeve is being extracted, to hold the core in place during tool extraction. Other arrangements can also be used for holding the tissue core in place while the tool is extracted.

FIGS. 8A-8C illustrate the distal end portion of a coring and drug-delivery tool **138** constructed according to another embodiment of the invention. As seen, the tool includes a tipped needle having an axial bore **142** through which a blade **144** is received and a drug-delivery bore **146** through which a drug solution or suspension can be delivered from the needle. Blade **144** is an elongate, flexible metal blade that has a substantial bend at **144a** adjacent its distal end, between a proximal guide segment **142b**, and a distal cutting segment **144c**.

In operation, the needle is introduced through the pericardium or endocardium into the myocardium at a selected target-area site where injury and optionally, growth factor is to be placed. During this introducing step, blade **144** is retracted into the bore of the needle. As the needle is being inserted a selected depth into the myocardial tissue, the blade is moved

out of the needle bore. As the bend in the blade passes through the outer tip of the needle, the tension in the blade causes the distal segment of the blade to extend away from the axis of the needle, as illustrated in FIG. 8B, which shows a partial angle bend, and FIG. 8C, which shows a full right angle bend. The needle is then rotated to produce a conical section in the tissue defined by the distal blade's movement through a complete rotation.

When the blade is partially extended as in FIG. 8B, such a rotation produces a conical core injury **148** such as shown in FIG. 9A, where the epicardial, myocardial, and endocardial layers are indicated at **150**, **152**, **154**, respectively. After formation of the conical cut in the myocardial tissue, a growth factor solution of suspension may be introduced into the injury site under pressure through bore **146** in the needle. The separated tissue allows the drug agent to be received in bolus form at the site, where it distributes about the site of the injury and ultimately is absorbed into the cells adjacent the injury. In this way, a growth factor agent can be placed and distributed over a desired area within the myocardium.

Likewise, when the cutting blade is extended passed its bend, and therefore assumes a full right angle in its cutting segment, as in FIG. 8C, rotation of the needle produces a substantially planar, circular cut such as indicated at **155a**, **155b**, and **155c** in FIG. 9B. The three cuts in FIG. 9B were produced by making successively shallower circular cuts in the tissue, with retracting and extending the cutting blade at each new depth in the myocardium. At each circular cut, drug may be introduced, essentially filling the circular space cut into the tissue.

Method and Device for Sustained Wire Injury

Another device for generating an injury in accordance with the invention is illustrated in FIGS. 10-13. This device is adapted to be remotely activated at periodic intervals to produce recurrent mechanical or thermal injury at implantation sites throughout a target area over a total period sufficient to convert initial capillary blush induced at the implantation sites into arterioles.

One such device **156** comprises an elongate wire **158** formed with barbs, such as barbs **160**, along its length. Device **156** preferably further includes a flexible thread **162**, one end of which is attached to wire **158** and the other end of which engages an external hook **164**.

Placement of wire **158** is illustrated in FIG. 10. The wire may be inserted into the subject using a hollow needle **166** which includes a funnel-shaped guide **168** at its proximal end. The needle is inserted into the subject so that a portion **170** of the needle extends through a target area in the myocardium which includes an underperfused region **172**, as shown in FIG. 10. The wire is then inserted into the hollow portion of the needle, such that when the needle is removed, the wire is implanted in the target area and extends through region **172** in close proximity to healthy tissue **174**. Multiple wires may be inserted, as shown in FIG. 10.

After insertion, each wire is periodically retracted a small amount, in accordance with the principles of the invention. A crank mechanism **176** in connection with a sleeve **178** that extends through the chest wall may be used to retract the wire, as shown in FIG. 11. Other suitable mechanisms may also be used.

At periodic intervals of between 1-7 days, the wire is retracted an indexed amount of about 1 cm in the direction of arrow A by moving the crank handle in the direction of arrow B or otherwise pulling the wire to effect the retraction. These times and distances are exemplary only; the amount of removal and the periodic intervals at which the wire is incrementally removed will vary depending on the healing

response curve desired. The result, as shown at 180 in FIG. 12, is that each indexed (e.g., 1 cm) retraction creates a new or fresh tearing injury that promotes angiogenesis.

The details of the construction of wire **158** are illustrated in FIG. 13. The wire is preferably between 0.002" to 0.005" stainless wire and formed of a bioerodable, ferromagnetic material. The wire preferably has 3-4 barbs spaced along its length approximately 1 cm apart, with the barbs themselves preferably being stainless and 0.010 type sharp bumps, although the number of barbs as well as their size and spacing will depend on the desired healing response.

In accordance with the principles of the invention, the wire is retracted in steps that are matched to a desired healing response curve. Periodic and discrete retraction of the wire along a predetermined track or path re-injures the tissue and results in a timed sequential injury that promotes arterioles to grow along the track in a more organized pattern, and thus concentrates blood flow along the track. The device may be shaped in other ways as well, including conduits for drug additions.

Method and Device for Endocardial Injury

FIG. 14 illustrates one embodiment of a tool **184** for use in producing an injury at selected locations on the inner endocardial wall of a heart ventricle. As discussed above, the purpose of this injury is to stimulate angiogenesis that can supply blood from the ventricle chambers of the heart to underperfused regions in the ventricle wall.

Tool **184** generally includes a handle **186** by which the operator guides and operates the tool, an elongate, rigid handle extension **188**, and a cutter element **190** formed at the distal end of the handle extension. The cutter element has a curved shape, as shown, allowing the element to be placed firmly against the curved wall portion of a ventricle chamber during operation, after (i) the cutter element is introduced through the heart muscle into the ventricle chamber, and (ii) the handle is manipulated to draw the cutter element against a ventricle wall surface.

The cutter element has a recessed segment **192** along which a cutter blade **194** is movable in guide tracks (not shown) under the influence of a cable **196** attached to the blade and a motor **198** housed in handle **186**. Control of blade motion is through a switch **200** which activates the motor. A cutter retreat lever **202** is used to reset the blade to its distal cutting position.

In operation, and with additional reference to FIG. 15, the tool is moved through a previously installed introducer sleeve **204** having a deformable seal that prevents blood flow from the ventricle chamber. The tool is placed inside the ventricle wall, indicated at **206**, and placed against a wall region adjacent an underperfused region. The cutter blade is now activated to form a shallow channel injury **208** in the ventricle wall, as illustrated in FIG. 15. The tool is dimensioned to produce a channel of about 1-5 mm, preferably 2-3 mm in width and 0.5-2 mm, preferably about 1 mm, in depth. After each cut, the tool is moved to form another cut in an adjacent target area, until the plurality of cuts corresponding to the region of the underperfused region are made. The channels are typically about 1-3 cm long, and spaced about 0.5 to 1 cm apart. After the cutting operation, the tool is withdrawn, then the introducer sleeve is removed.

The tool may be adapted to produce a variety of ventricle-wall injuries, such as needle injury, coring injury, or laser injury by replacing the movable cutter blade with other injury-producing elements. For example, in the case of a needle injury, the cutter blade may be replaced by a movable needle housing through which a needle can be selectively extended, e.g., by a suitable control in the handle, at spaced

intervals along the track of the cutter segment. Likewise, a coring element designed to produce a myocardial coring injury, such as detailed in Section III above, may be used. In addition, or alternatively, the tool may be equipped with a needle or biolistic element for introducing growth factor at selected sites in the selected target area between the ventricle wall and the underperfused region.

The injury and/or growth-factor stimuli introduced by the tool functions initially to stimulate angiogenesis in the region between the endocardial wall and the underperfused region, serving, in effect, to make the endocardium more porous to blood flow from the ventricle chamber to an adjacent region in need of more oxygen. The capillaries forming a capillary bed in response to the stimuli function as one-way blood-cell carriers, through the vaso-action motion of capillaries. Thus, the heart becomes leakier, but only in the desired endocardium-to-myocardium direction. With sustained injury, such as is produced by a channel injury or laser injury, the continued angiogenic stimulus leads to the formation of an arteriole or more robust capillary bed feeding the underperfused region from the ventricle wall. Alternatively, the initial stimulus can be followed by an exercise regimen, as described below, to place a sustained demand on the growing vasculature.

This embodiment of the treatment method may be carried out in conjunction with other aspects of the invention that treat the underperfused region from the "epicardial" side of the underperfused region, or independently. An advantage of the combined methods is that the region in need of greater oxygen supply is revascularized from both sides of the heart wall. A second advantage is that the sustained demand placed on the region, such as by exercise, will contribute to vascularization being created on both inner and out sides of the underperfused region.

Method and Device for Sustained Stimulus by Exercise

In addition to long-term or recurrent injury, the oxygen demand within the underperfused region can be sustained by requiring the patient to achieve a desired level of exercise, as measured by an elevated heart rate, e.g., a 50-100% increase in heart rate over the resting rate, for a selected daily period, typically at least ½ hour per day. The exercise regimen should begin at least by week 4 following the initial angiogenic stimuli, and be continued at least through week 15-16 following the initial stimuli. The desired end point is conversion of capillary blush to a more robust arteriole system, and the transformation of vasculature can be followed by imaging techniques noted above.

If desired, a pacemaker may be added to stimulate the heart at regular exercise intervals.

The monitoring and tracking components of the device are illustrated in FIG. 16. The device here takes the form of a wrist-worn device **210** having against-the skin electrodes **212**, **214**, for detecting pulse rate. Other devices can be designed, for example to be strapped around the chest of the wearer, with against-the-skin electrodes being located at the chest region over the heart. The front face of the device includes a display window **216** and a switch **218** which sends an "activate" signal to the device, when the user initiates each daily exercise program.

The operation of the device is illustrated in FIG. 17, which is a flow diagram of the logic steps carried out by the device. Initially, when the device is strapped in place, the user allows the device to measure an average resting pulse, indicated by function **220**, which provides a baseline of heart rate. By activating the device for exercise measurement, indicated by functions **222** and **224**, the device is set to begin monitoring and timing the extent and duration of heart exercise over a given exercise period. The device monitors the heart rate and

indicates to the user when an adequate rise in heart rate has been achieved, as indicated by function 226. Once the elevated heart-rate threshold is reached, the device begins measuring the duration of the period of elevated heart rate, indicated by function 228, and displays both heart rate and duration data to the user. When an integrated, elevated heart rate/duration threshold is reached, indicating a sufficient heart exercise for that day, the device so signals the user, as indicated by function 230. The daily exercise data is stored in a suitable storage device 232 that keeps track of the (i) days when heart-rate exercise was measured, (ii) the integrated elevated heart rate/duration value on each exercise day, and the total days remaining in the exercise regimen, and this data can be supplied to the user on demand, e.g., at the beginning of each daily exercise.

At the end of the exercise regimen, the user may be examined to confirm formation of arteriole blood supply to the underperfused region. Alternatively, the patient will be able to report improvement in vascularization of the heart through such measures as increased exercise tolerance, quality of life, or relief from cardiac insufficiency symptoms, such as resting or exercise-induced chest pain.

From the foregoing, it can be appreciated how various objects and features of the invention are met. In particular, the present invention addresses the problem: how can an underperfused region of the heart, and therefore a region at risk or infarct and muscle loss, be efficiently re-supplied with an adequate supply of oxygen with a minimum of anatomical damage to the heart.

Although the prior-art recognized the ability of angiogenic stimuli, including both growth factors and injury, to stimulate angiogenesis in the heart, the present invention extends this solution in two key respects. First, by imaging the heart to identify and localize the underperfused region, and localizing this region with respect to the adjacent supply of oxygenated blood, the sites of angiogenic stimulus can be localized to optimally extend from the source of oxygenated blood to ward the site of demand (the underperfused region). This significantly enhances of the efficiency of capillary blush formation. Secondly, by applying a sustained demand to the region where capillary blush has occurred, the initial capillary formation is assured of developing into a stable and robust vascular supply to the underperfused region.

What is claimed is:

1. A method of treating a patient at risk of loss of cardiac function by cardiac ischemia, comprising

(a) imaging the patient's heart, or a portion thereof, to identify (i) an underperfused region of cardiac muscle, (ii) a source of oxygenated blood that is proximate a boundary of the underperfused region, and (iii) a target area that includes said underperfused-region boundary and a tissue expanse lying between said oxygenated blood supply and said boundary;

(b) at each of a plurality of sites throughout the target area, introducing a stimulus effective to stimulate angiogenesis in myocardial tissue and form a capillary network from the source of oxygenated blood to the underperfused region, wherein the stimulus is an injury produced by a stimulus selected from the group consisting of a mechanical, laser, chemical, thermal, or ultrasonic stimulus; and

(c) sustaining a demand for oxygen at the underperfused region for a period sufficient to convert the capillary network into an arterial network.

2. The method of claim 1, wherein the injury is produced by a mechanical stimulus comprising a mechanical cutting device effective to produce an annulus of injury about a core of healthy cells.

3. The method of claim 1, wherein the stimulus is a mechanical stimulus produced by introducing into each of said sites, a wire device having a barbed segment, and the method further includes periodically moving the wire devices relative to the heart, to produce a prolonged angiogenic stimulus at said site.

4. The method of claim 1, wherein the demand for oxygen at the underperfused region is sustained by chemical methods.

5. The method of claim 1, wherein the demand for oxygen at the underperfused region is sustained by at least one implant adapted to elicit a foreign body response.

6. The method of claim 1, wherein the demand for oxygen at the underperfused region is sustained by at least one viral carrier.

7. The method of claim 1, wherein the demand for oxygen at the underperfused region is sustained by requiring the patient to follow an exercise regimen.

8. The method of claim 1, wherein the stimulus is introduced at a first time, and the demand for oxygen at the underperfused region is sustained by introducing a second stimulus at a second time different from the first time.

9. A method of treating a patient at risk of loss of cardiac function by cardiac ischemia, comprising

(a) imaging the patient's heart, or a portion thereof, to identify (i) an underperfused region of cardiac muscle, (ii) a source of oxygenated blood that is proximate a boundary of the underperfused region, and (iii) a target area that includes said underperfused-region boundary and a tissue expanse lying between said oxygenated blood supply and said boundary;

(b) at each of a plurality of sites throughout the target area, introducing a stimulus effective to stimulate angiogenesis in myocardial tissue and form a capillary network from the source of oxygenated blood to the underperfused region,

wherein the source of oxygenated blood is one in which arteries less than about 1 mm branch into a plurality of surrounding arterioles, and in which arterioles with inner lumen diameters between about 50-200 microns are plentiful, and said sites are spaced from one another at a spacing of between 0.5 to 1 cm; and

(c) sustaining a demand for oxygen at the underperfused region for a period sufficient to convert the capillary network into an arterial network.

10. A method of treating a patient at risk of loss of cardiac function by cardiac isehemia, comprising

(a) imaging the patient's heart, or a portion thereof, to identify (i) an underperfused region of cardiac muscle, (ii) a source of oxygenated blood that is proximate a boundary of the underperfused region, and (iii) a target area that includes said underperfused-region boundary and a tissue expanse lying between said oxygenated blood supply and said boundary,

wherein the underperfused region is in a myocardial region of either of the patient's ventricles, the source of oxygenated blood is the interior of the underperfused heart ventricle region, and the target area includes the region of ventricle endocardium underlying the underperfused region;

(b) at each of a plurality of sites throughout the target area, introducing a stimulus effective to stimulate angiogen-

19

esis in myocardial tissue and form a capillary network from the source of oxygenated blood to the underperfused region;

wherein said stimulus is a mechanical injury produced by forming at selected target sites in the target area, 5 elongate channels in the endocardium of the ventricle, where the depth and width of said channels, combined with the blood turbulence produced within the ventricle, is such as to minimize accumulation of blood clot material in the channels; and

(c) sustaining a demand for oxygen at the underperfused region for a period sufficient to convert the capillary network into an arterial network.

11. The method of claim 10, wherein the channels have both width and depth dimension between about 1-5 mm. 15

12. The method of claim 10, further including the step of introducing an angiogenic growth factor into target-area sites between the underperfused region and adjacent portions of an inner ventricle wall.

13. The method of claim 10, further including the steps of 20 (d) imaging the heart to identify (i) as a second source of oxygenated blood, coronary arterioles in the epicardial region of the ventricle overlying the underperfused heart-ventricle region, (ii) as a second target area, the

20

area between the second source of oxygenated blood supply and the underperfused region, and the adjacent boundary of the underperfused region; and

(e) introducing into the second target area, at selected sites therein, a stimulus effective to stimulate angiogenesis in the target area.

14. The method of claim 10, wherein the demand for oxygen at the underperfused region is sustained by chemical methods.

15. The method of claim 10, wherein the demand for oxygen at the underperfused region is sustained by at least one implant adapted to elicit a foreign body response.

16. The method of claim 10, wherein the demand for oxygen at the underperfused region is sustained by at least one viral carrier.

17. The method of claim 10, wherein the demand for oxygen at the underperfused region is sustained by requiring the patient to follow an exercise regimen.

18. The method of claim 10, wherein the stimulus is introduced at a first time, and the demand for oxygen at the underperfused region is sustained by introducing a second stimulus at a second time different from the first time.

* * * * *

UNITED STATES PATENT AND TRADEMARK OFFICE
CERTIFICATE OF CORRECTION

PATENT NO. : 7,392,077 B2
APPLICATION NO. : 10/822600
DATED : June 24, 2008
INVENTOR(S) : Richard L. Mueller et al.

Page 1 of 1

It is certified that error appears in the above-identified patent and that said Letters Patent is hereby corrected as shown below:

In Title page, item (*) Notice, line 4, please insert --This patent is subject to a terminal disclaimer--.

In claim 9, column 18, line 33, delete "region." and insert --region,-- therefor.

In claim 10, column 18, line 52, delete "isehemia" and insert --ischemia-- therefor.

Signed and Sealed this

Twenty-first Day of October, 2008

A handwritten signature in black ink, appearing to read "Jon W. Dudas". The signature is stylized with a large initial "J" and a cursive "Dudas".

JON W. DUDAS
Director of the United States Patent and Trademark Office

专利名称(译)	用于治疗心脏缺血导致心脏功能丧失风险的患者的方法		
公开(公告)号	US7392077	公开(公告)日	2008-06-24
申请号	US10/822600	申请日	2004-04-12
申请(专利权)人(译)	SCIMED生命系统		
当前申请(专利权)人(译)	BOSTON SCIENTIFIC SCIMED , INC.		
[标]发明人	MUELLER RICHARD L CHEE U HIRAM		
发明人	MUELLER, RICHARD L. CHEE, U. HIRAM		
IPC分类号	A61B5/00 A61B17/00 A61B17/32 A61B17/34 A61B18/14 A61B18/22 A61B19/00		
CPC分类号	A61B17/32053 A61B17/3417 A61B17/3478 A61B18/1492 A61B18/22 A61B2017/00247 A61B2018/00392 A61B2019/306 A61B18/20 A61B2090/036		
优先权	60/163698 1999-11-05 US		
其他公开文献	US20040254451A1		
外部链接	Espacenet USPTO		

摘要(译)

公开了用于治疗已经因心肌缺血而丧失或有丧失心脏功能风险的患者的各种方法和装置。治疗包括首先对患者的心脏或其一部分进行成像，以识别心肌的灌注不足区域，以及靠近灌注不足区域的氧合血液源。在灌注不足的区域和含氧血液源之间，选择目标区域，其中引入热或机械损伤，并且任选地重新引入，以转换由损伤引起的初始毛细血管发白。

