



US007223237B2

(12) **United States Patent**
Shelchuk

(10) **Patent No.:** **US 7,223,237 B2**
(45) **Date of Patent:** **May 29, 2007**

(54) **IMPLANTABLE BIOSENSOR AND METHODS FOR MONITORING CARDIAC HEALTH**

(75) Inventor: **Anne M. Shelchuk**, Cupertino, CA (US)

(73) Assignee: **Pacesetter, Inc.**, Sunnyvale, CA (US)

(*) Notice: Subject to any disclaimer, the term of this patent is extended or adjusted under 35 U.S.C. 154(b) by 406 days.

(21) Appl. No.: **10/830,850**

(22) Filed: **Apr. 22, 2004**

(65) **Prior Publication Data**

US 2005/0240088 A1 Oct. 27, 2005

(51) **Int. Cl.**
A61B 5/00 (2006.01)

(52) **U.S. Cl.** **600/309**

(58) **Field of Classification Search** **600/309, 600/325, 333; 607/22**

See application file for complete search history.

(56) **References Cited**

U.S. PATENT DOCUMENTS

4,202,339	A	5/1980	Wirtzfeld et al.	128/419
4,940,052	A *	7/1990	Mann et al.	607/17
6,049,727	A *	4/2000	Crothall	600/310
6,049,728	A *	4/2000	Chou	600/316
6,109,098	A	8/2000	Dukhin et al.	73/64.42
6,122,536	A *	9/2000	Sun et al.	600/341
6,645,144	B1	11/2003	Wen et al.	600/437
7,074,194	B2 *	7/2006	Crosby et al.	600/508
2003/0022235	A1 *	1/2003	Dahlen et al.	435/7.1
2003/0130570	A1	7/2003	Krivitski	600/322

OTHER PUBLICATIONS

Dukhin, et al., "Acoustic and Electroacoustic Spectroscopy for Characterizing Concentrated Dispersions and Emulsions", *Advances in Colloid and Interface Science* 92 (2001) 73-132.

Dukhin, et al., "Ultrasound for Characterizing Colloids, Particle Sizing, Zeta Potential, Rheology", Dispersion Tehcnology, Inc., NY, USA, First Edition, 2002, 18 pages.

Schneditz, et al., "A Sound-Speed Sensor for the Measurement of Total Protein Concentration in Disposable, Blood-Perfused Tubes", *Journal of the Acoustical Society of America*, American Institute of Physics, New York, US vol. 86, No. 6, Dec. 1989, pp. 2073-2080.

Wen, et al., "Ultrasonic Imaging of the Electroacoustic Effect in Macromolecular Gels", *Ultrasonic Imaging*, Dynamedia, Inc., vol. 20, No. 4, Oct. 1998, pp. 288-297.

Savateeva et al., "Optical properties of blood at various levels of oxygenation studied by time resolved detection of laser-induced pressure profiles", *Proceedings of SPIE, Biomedical Optoacoustics III*, vol. 4618, 2002, pp. 63-75.

* cited by examiner

Primary Examiner—Eric Winakur

Assistant Examiner—Etsub Berhanu

(74) *Attorney, Agent, or Firm*—Steven M. Mitchell

(57) **ABSTRACT**

The ability to continuously monitor concentrations of any of a plurality of blood-borne substances, such as proteins, improves patient monitoring and overall care through early detection of cardiac threats. Ultrasound-based technology used in analytical chemistry to determine amounts of particles suspended in a colloidal composition can be employed in an implantable sensor to monitor levels of many different substances in the blood. A sensor system is implanted in or near a blood vessel in the body and generates an electric or acoustic field directed at that blood vessel. A receiver near the generator detects energy emitted once the assaulting field is turned off. Changes in the relative amounts of the substance(s) being monitored appear as changes in the amount of energy emitted once the assaulting field is removed. The sensor may be implemented in an implantable cardiac therapy device. A non-implantable or transcutaneous sensor may also be used to monitor cardiac health.

34 Claims, 13 Drawing Sheets

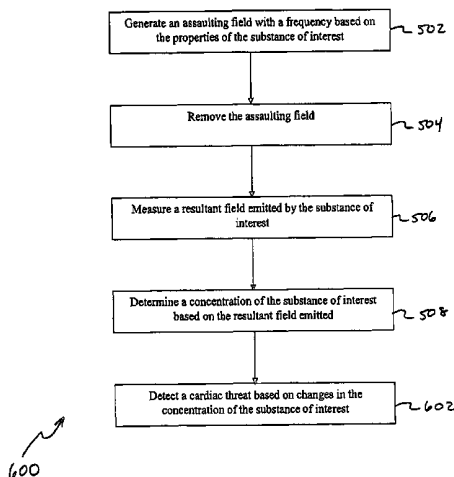

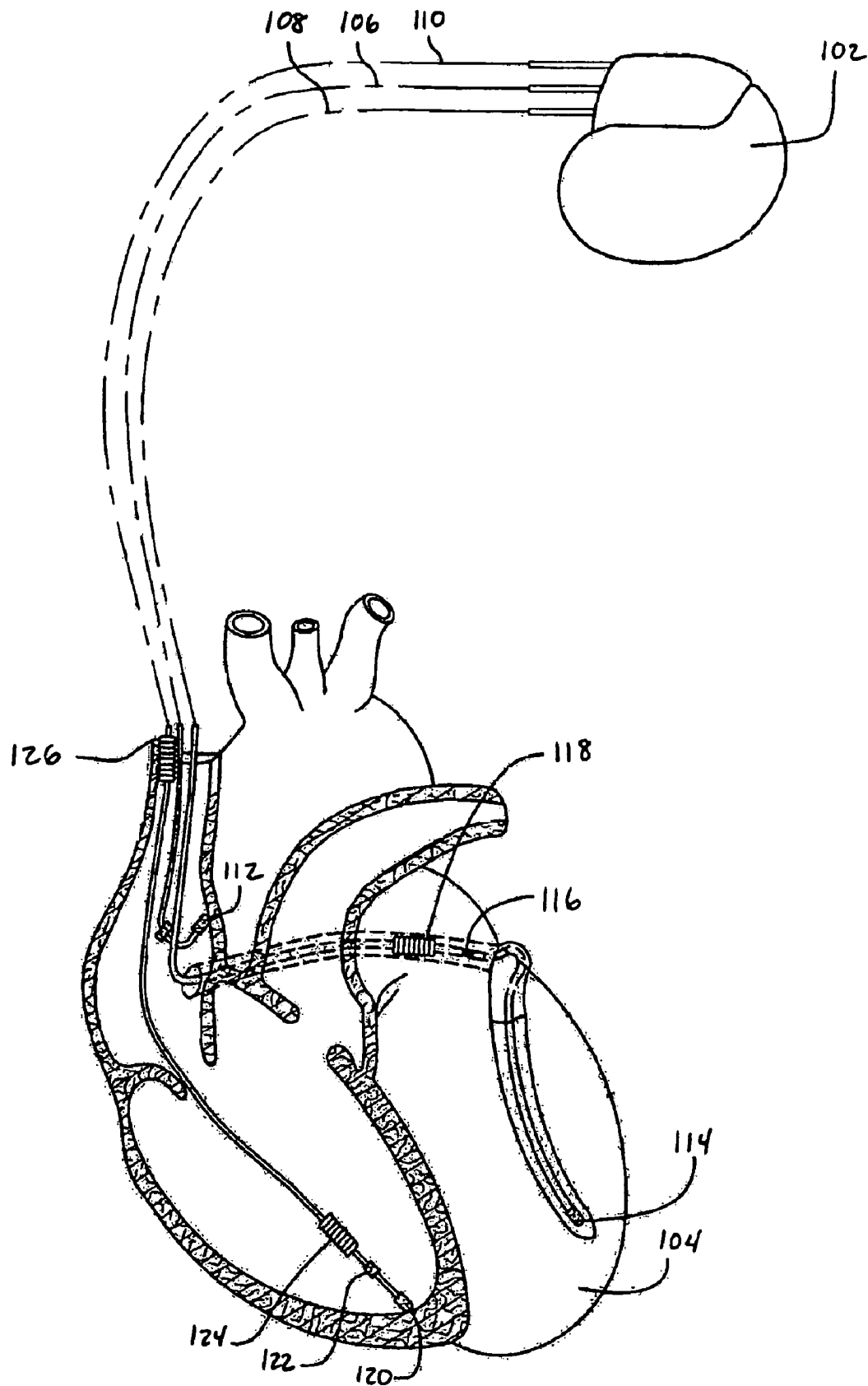

FIG. 1A

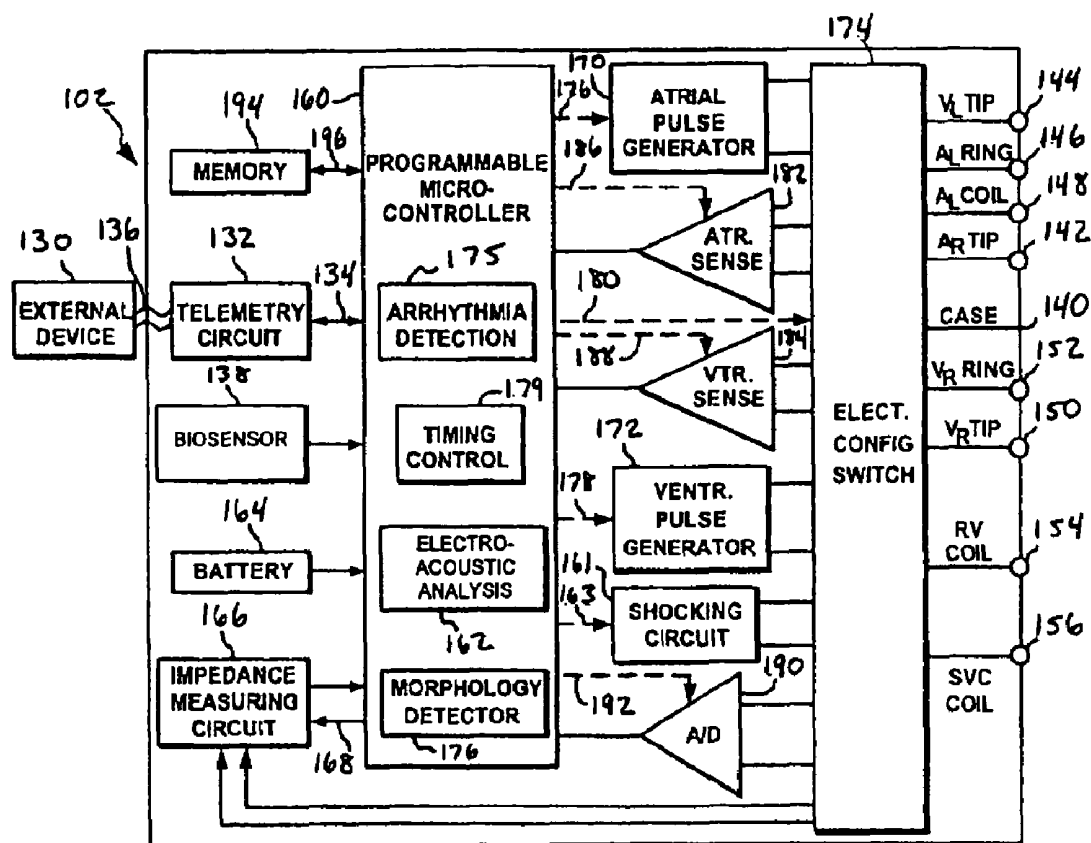

FIG. 1B

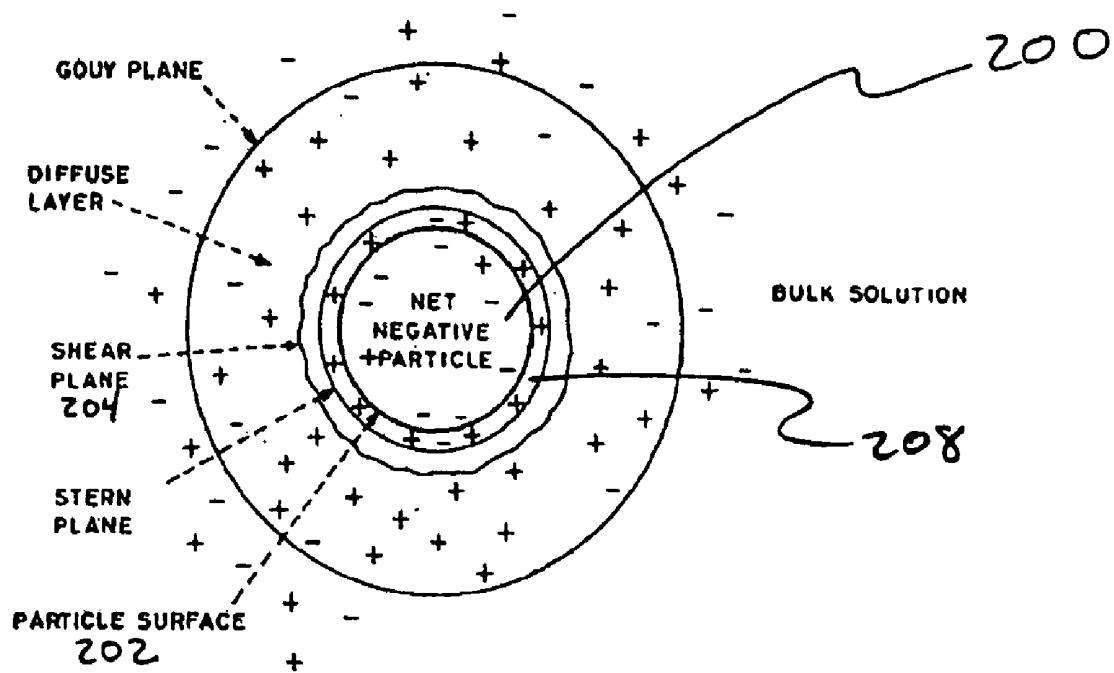

FIG. 2A

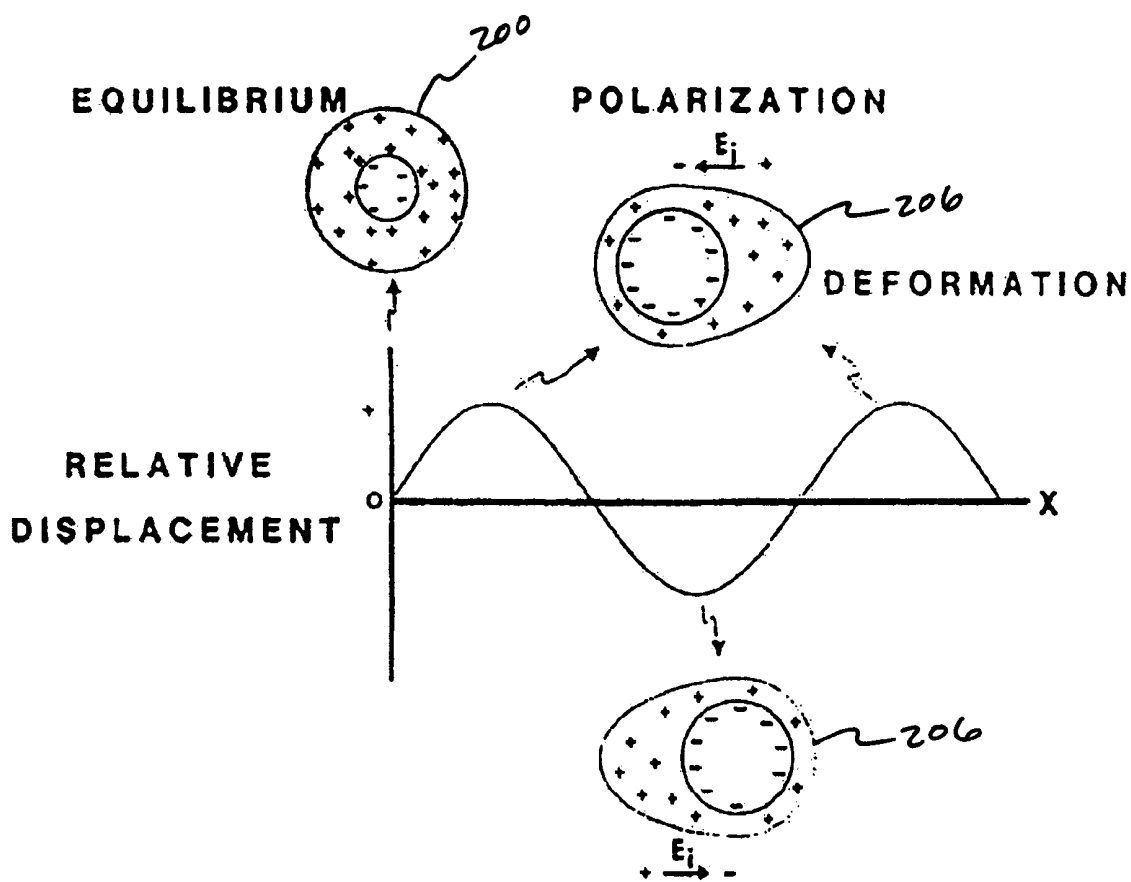

FIG. 2B

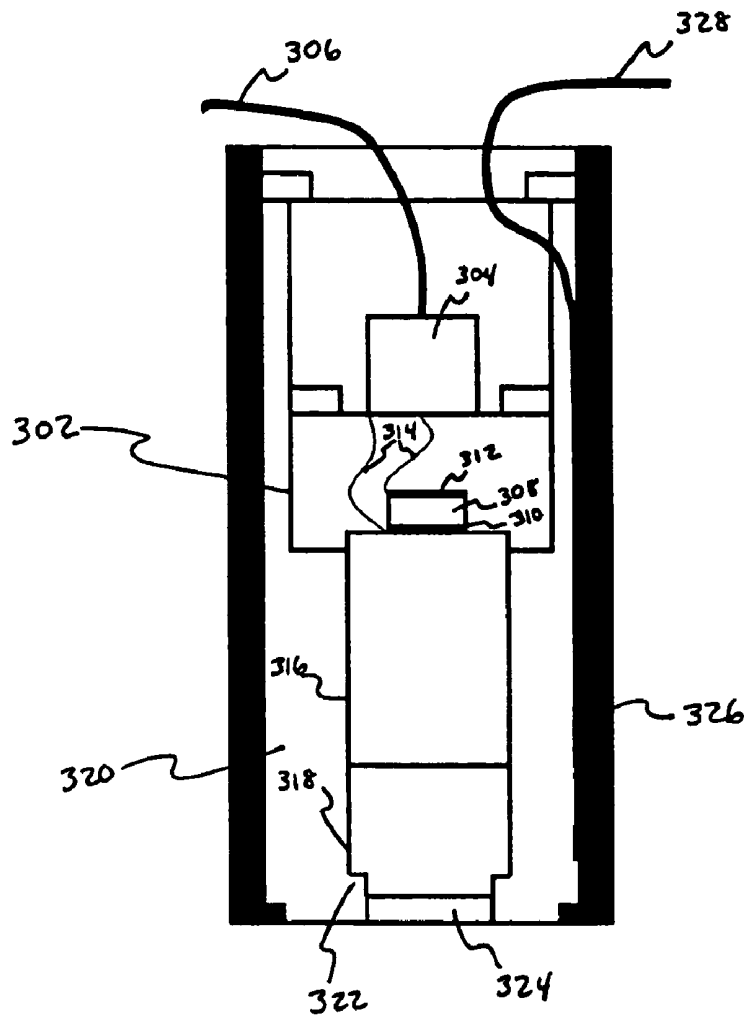

FIG. 3A

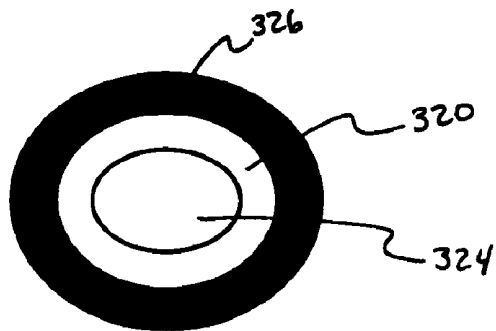

FIG. 3B

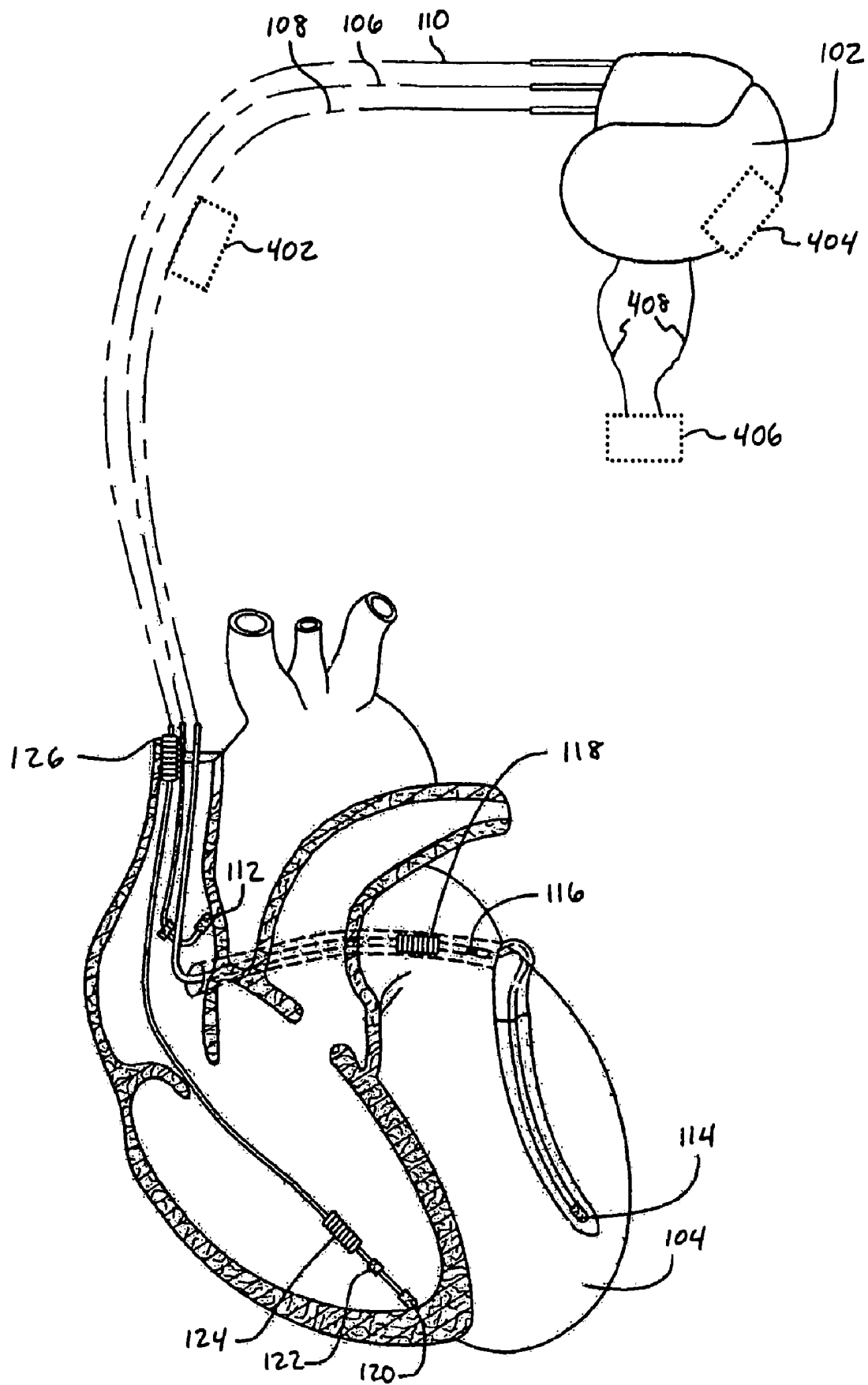

FIG. 4

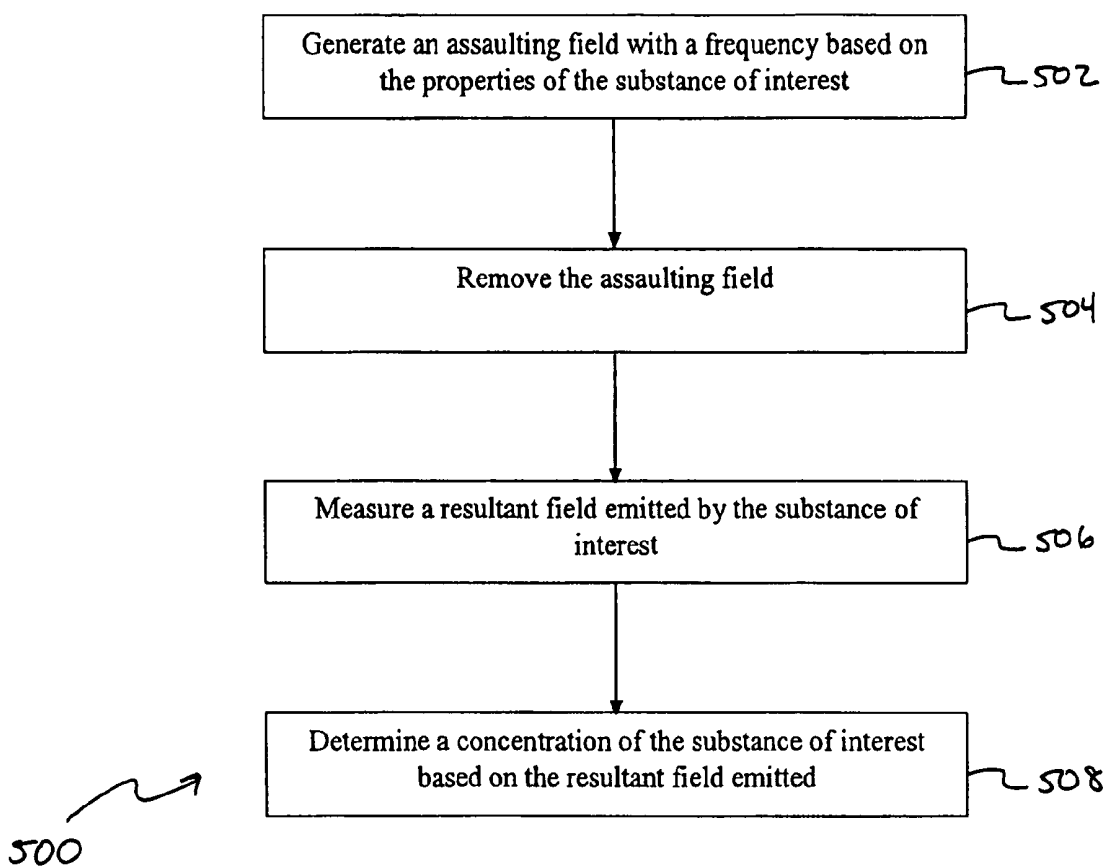
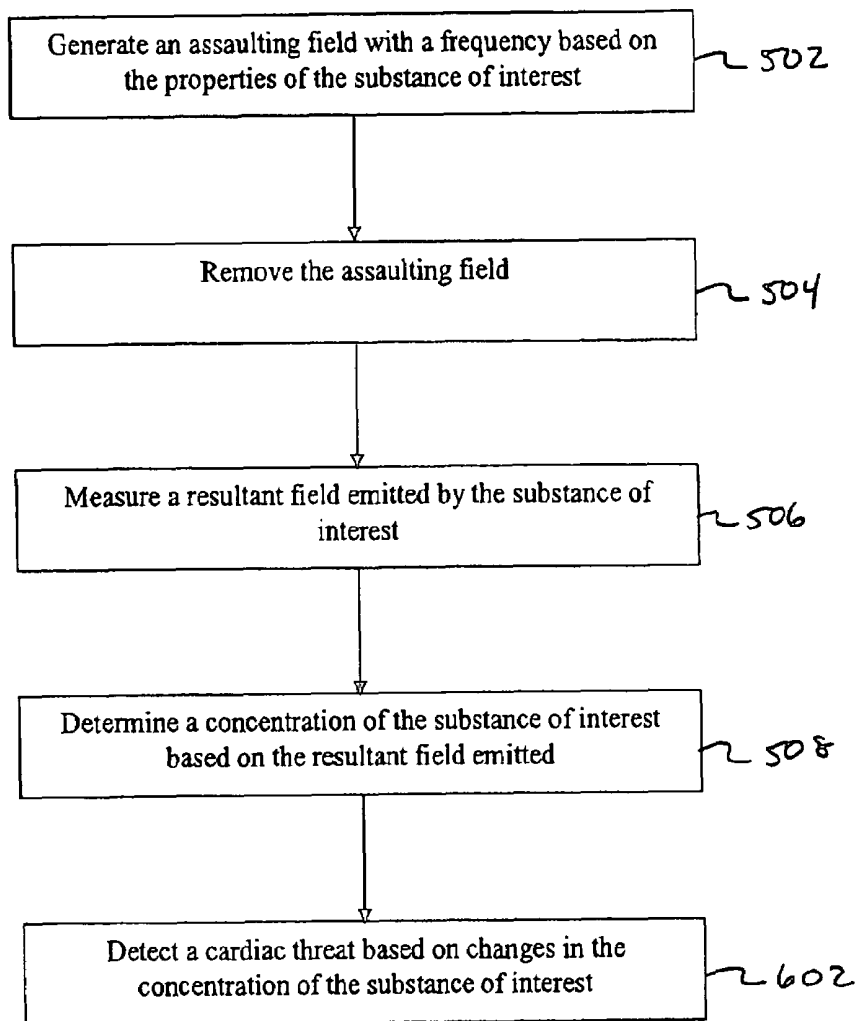

FIG. 5



600 ↗

FIG. 6

704 Colloidal Vibration Current (CVI)

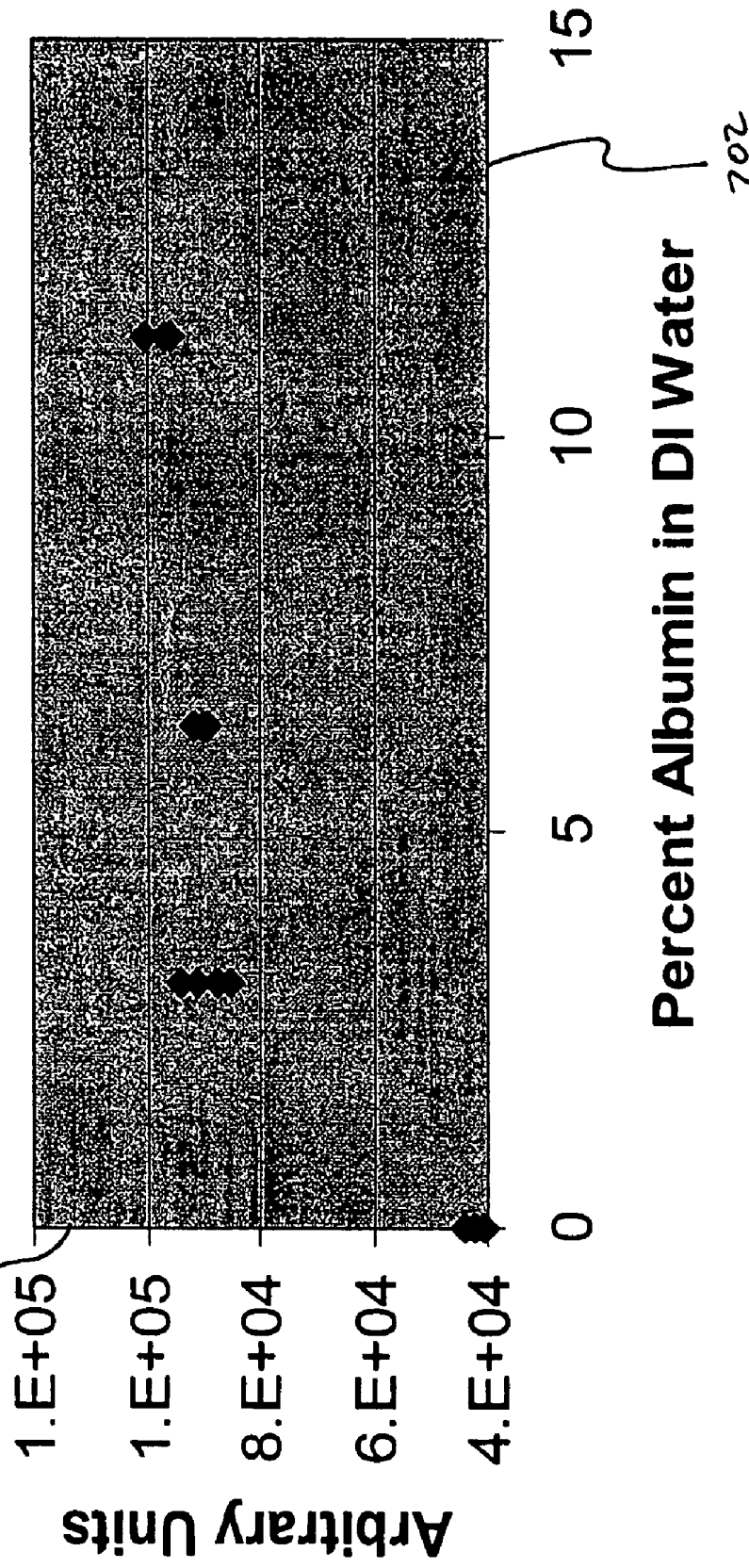
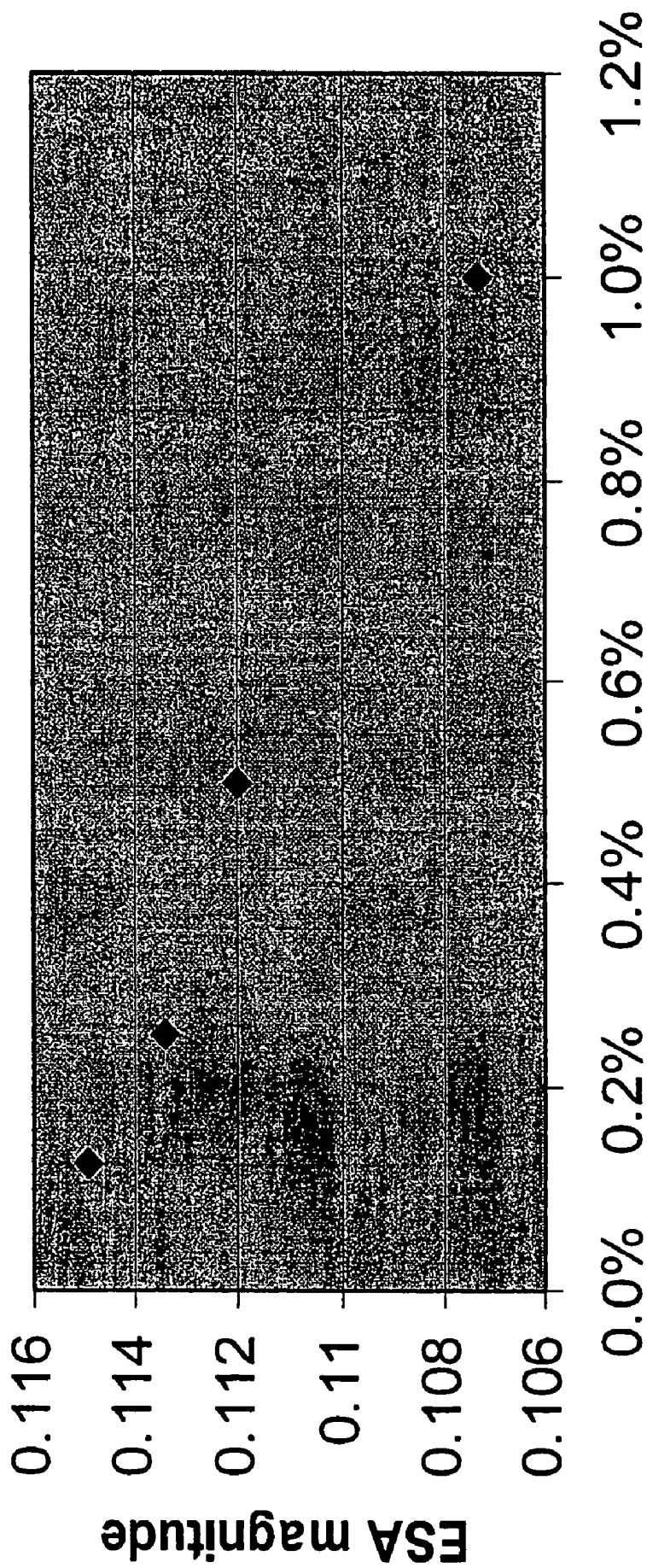
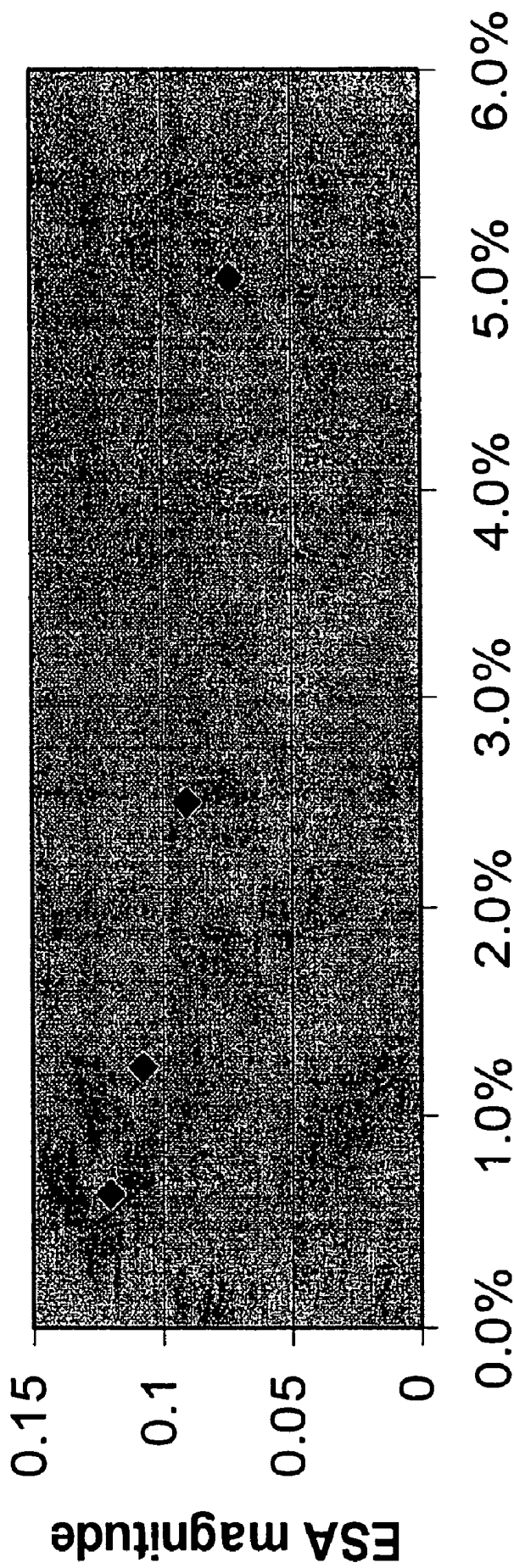

FIG. 7



Fibrinogen in saline

FIG. 8



Albumin in saline

FIG. 9

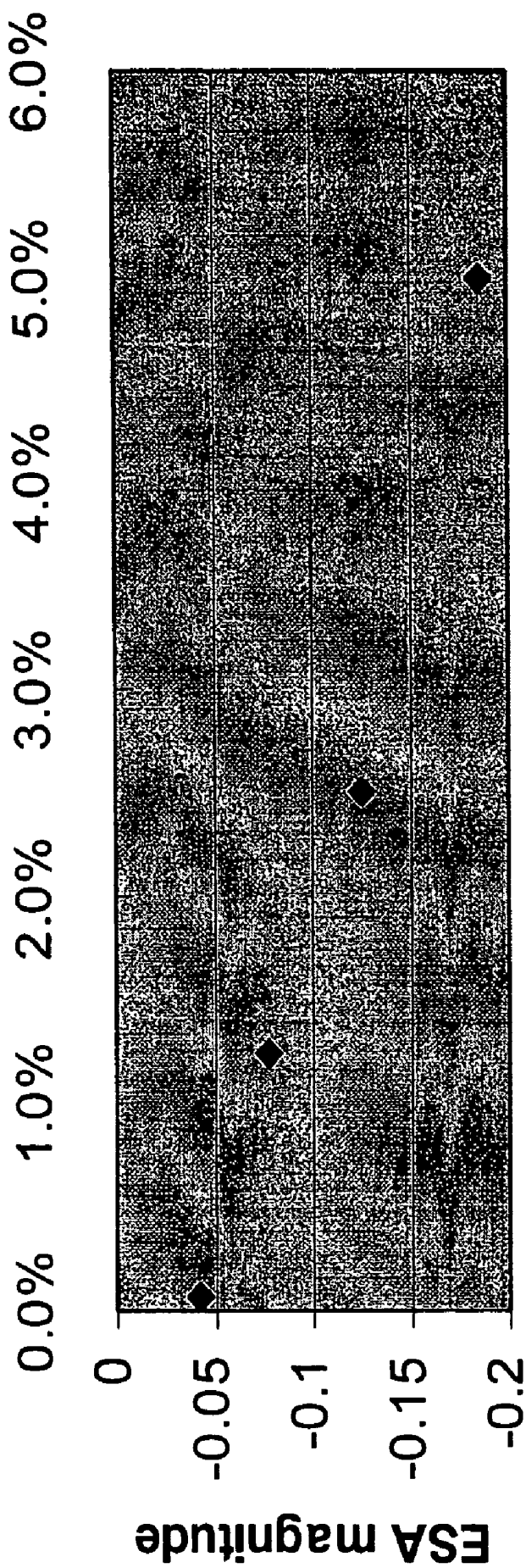

Albumin in DI water

FIG. 10

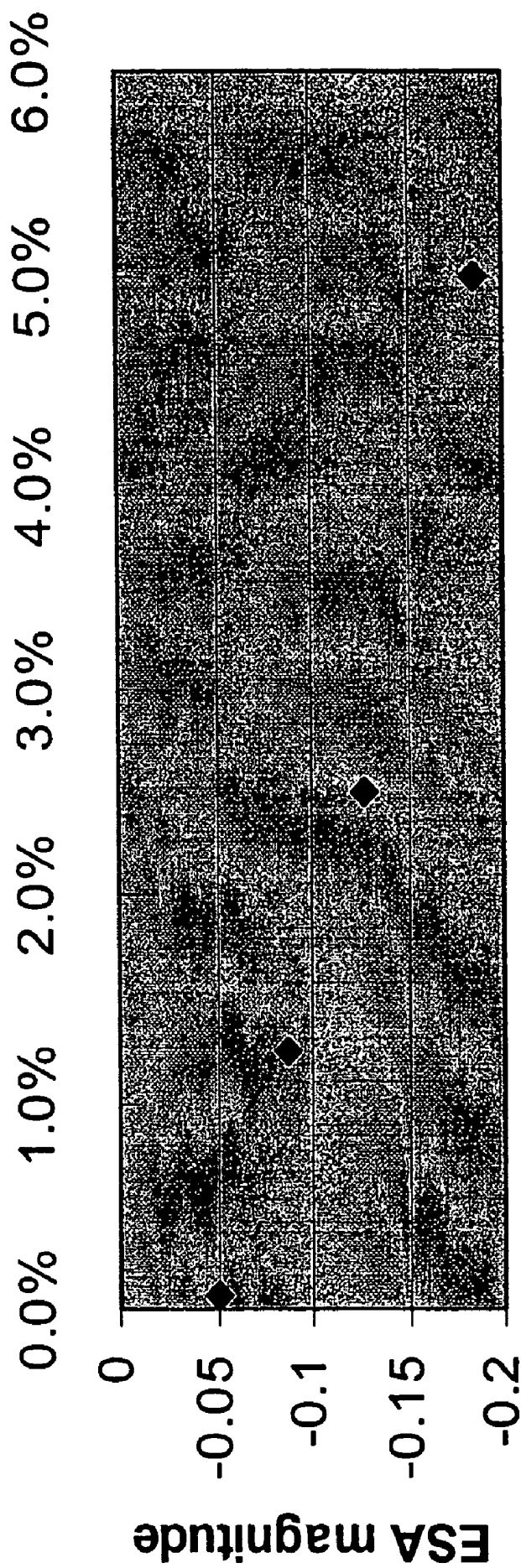

Albumin in DI water

FIG. 11

IMPLANTABLE BIOSENSOR AND METHODS FOR MONITORING CARDIAC HEALTH

BACKGROUND OF THE INVENTION

1. Field of the Invention

This invention relates to electroacoustic technology used in implantable devices.

2. Related Art

When an acoustic field is applied to a colloid containing particles with a charge, the arrangement of solvent molecules surrounding the solute particles (the double-layer) is disrupted. When the acoustic field is removed, the solvent molecules reassemble themselves and give off an electric field proportional to the energy required for the initial disruption of solvent molecules. Alternatively, when a colloid is transiently exposed to a changing electric field, the same disruption of solvent molecules takes place and the reassembly of the double-layer emits an acoustic field. These principles are employed in analytical chemistry to characterize the composition and stability of colloids.

Colloidal chemistry has historically been used for inorganic compounds such as paint, lotions, and other slurries. Organic compounds, however, have not been investigated using these techniques because they were considered too small for colloidal chemistry to be effective.

SUMMARY OF THE INVENTION

Proteins are relatively large particles that have a surface charge distribution. Hence, the analytical chemistry technique can be employed to monitor levels of suspended substances, including proteins, in a biomedical colloid such as blood. Although the description herein will typically refer to detecting levels of proteins in blood, one skilled in the art will recognize that the present invention may also be used to detect other substances in organic fluids.

The present invention provides a biosensor for detecting proteins in blood. The biosensor adapts the techniques from traditional inorganic colloidal chemistry for use in an organic setting. In an embodiment, the biosensor is used in conjunction with an implantable device, such as a pacemaker or implantable cardioverter defibrillator. The biosensor may be physically connected to the implantable device, or it may be separated by a set of transmission lines or by wireless transmission capabilities. In the implantable embodiment, the biosensor is placed near a blood vessel or interstitial fluid, and directs an assaulting field toward the vessel or fluid. The frequency of the assaulting field is chosen based on the protein of interest. The assaulting field may be an acoustic field or an electric field. When the assaulting field is turned off, the fluid surrounding the proteins move to reassemble the double layer. This movement emits a resultant field. If the assaulting field is an acoustic field, the resultant field is an electric field. Conversely, if the assaulting field is an electric field, the resultant field is an acoustic field.

The relative concentration of the protein of interest can be determined from the magnitude of the resultant field. Over time, the relative concentration can be monitored by the implanted device or by a clinician. Depending on the proteins monitored, changes in protein concentration can be indicative of overall cardiac health, including any impending threats to cardiac health. For example, changes in the levels of peptides, such as brain natriuretic peptide ("BNP") and/or atrial natriuretic peptide ("ANP"), may be indicative

of impending heart failure exacerbation. In another example, changes in the levels of C-reactive protein, CK-MB, ischemia-modified albumin, Troponin I, Troponin T, Troponin C, and/or myoglobin may be indicative of myocardial ischemia and impending arrhythmia. Cardiac therapy may be administered in response to such changes in protein concentration.

In another embodiment, the biosensor is a transcutaneous biosensor, meaning that it measures the concentration of the substance of interest in vivo by transmitting an assaulting field through the skin.

In another embodiment, the biosensor is a standalone sensor. In this embodiment, the biosensor measures protein concentrations in external samples, such as a blood sample.

Further embodiments, features, and advantages of the present invention, as well as the structure and operation of the various embodiments of the present invention, are described in detail below with reference to the accompanying drawings.

BRIEF DESCRIPTION OF THE DRAWINGS/FIGURES

The accompanying drawings, which are incorporated herein and form a part of the specification, illustrate the present invention and, together with the description, further serve to explain the principles of the invention and to enable a person skilled in the pertinent art to make and use the invention.

FIG. 1A is a diagram of an example implantable cardiac therapy device ("ICTD") used in the present invention.

FIG. 1B is a block diagram of the example ICTD of FIG. 1A.

FIG. 2A is an illustration of a colloid double layer in a steady state arrangement.

FIG. 2B is an illustration of colloid double layer distortions caused by an assaulting field.

FIG. 3A is a block diagram of an example probe used in the present invention.

FIG. 3B is an alternative view of the example probe shown in FIG. 3A.

FIG. 4 is a diagram of example locations for an implantable biosensor of the present invention.

FIG. 5 is a flowchart of an embodiment of the present invention.

FIG. 6 is another flowchart of an embodiment of the present invention.

FIG. 7 is a graph of colloidal vibration current ("CVT") resulting from various concentrations of albumin in deionized water.

FIG. 8 is a graph of electrosonic amplitude ("ESA") resulting from various concentrations of fibrinogen in saline.

FIG. 9 is a graph of ESA resulting from various concentrations of albumin in saline.

FIG. 10 is a graph of ESA resulting from various concentrations of albumin in deionized water.

FIG. 11 is a graph of ESA resulting from various concentrations of albumin in deionized water.

The present invention will be described with reference to the accompanying drawings. The drawing in which an element first appears is typically indicated by the leftmost digit(s) in the corresponding reference number.

DETAILED DESCRIPTION OF THE
INVENTION

While specific configurations and arrangements are discussed, it should be understood that this is done for illustrative purposes only. A person skilled in the pertinent art will recognize that other configurations and arrangements can be used without departing from the spirit and scope of the present invention. It will be apparent to a person skilled in the pertinent art that this invention can also be employed in a variety of other applications.

It would be apparent to one of skill in the art that the present invention, as described below, may be implemented in many different embodiments of hardware, software, firmware, and/or the entities illustrated in the figures. Any actual software and/or hardware described herein is not limiting of the present invention. Thus, the operation and behavior of the present invention will be described with the understanding that modifications and variations of the embodiments are possible, given the level of detail presented herein. Before describing the invention in detail, it is helpful to describe an example environment in which the invention may be implemented.

A. Implantable Cardiac Therapy Devices

The present invention is particularly useful in the environment of an implantable cardiac therapy device. Implantable cardiac therapy devices include, for example, pacemakers and cardioverter defibrillators. The term “implantable cardiac therapy device,” or simply “ICTD,” is used herein to refer to any pacemaker or implantable cardioverter defibrillator (“ICD”). FIGS. 1A and 1B illustrate such an environment.

As shown in FIG. 1A, an exemplary ICTD 102 is in electrical communication with a patient’s heart 104 by way of three leads, 106, 108 and 110, suitable for delivering multi-chamber stimulation and pacing therapy. To sense atrial cardiac signals and to provide right atrial chamber stimulation therapy, ICTD 102 is coupled to implantable right atrial lead 106 having at least an atrial tip electrode 112, which typically is implanted in the patient’s right atrial appendage.

To sense left atrial and ventricular cardiac signals and to provide left-chamber pacing therapy, ICTD 102 is coupled to “coronary sinus” lead 108 designed for placement in the “coronary sinus region” via the coronary sinus for positioning a distal electrode adjacent to the left ventricle and/or additional electrode(s) adjacent to the left atrium. As used herein, the phrase “coronary sinus region” refers to the vasculature of the left ventricle, including any portion of the coronary sinus, great cardiac vein, left marginal vein, left posterior ventricular vein, middle cardiac vein, and/or small cardiac vein or any other cardiac vein accessible by the coronary sinus.

Accordingly, exemplary coronary sinus lead 108 is designed to receive atrial and ventricular cardiac signals and to deliver left ventricular pacing therapy using at least a left ventricular tip electrode 114, left atrial pacing therapy using at least a left atrial ring electrode 116, and shocking therapy using at least a left atrial coil electrode 118.

ICTD 102 is also shown in electrical communication with the patient’s heart 104 by way of an implantable right ventricular lead 110 having a right ventricular tip (“RV”) electrode 120, a RV ring electrode 122, a RV coil electrode 124, and a superior vena cava (“SVC”) coil electrode 126. Typically, right ventricular lead 110 is transvenously inserted into heart 104 so as to place the RV tip electrode 120

in the right ventricular apex so that RV coil electrode 124 will be positioned in the right ventricle and SVC coil electrode 126 will be positioned in the superior vena cava. Accordingly, right ventricular lead 110 is capable of receiving cardiac signals and delivering stimulation in the form of pacing and shock therapy to the right ventricle.

FIG. 1B shows a simplified block diagram of ICTD 102, which is capable of treating both fast and slow arrhythmias with stimulation therapy, including cardioversion, defibrillation, and pacing stimulation. While a particular multi-chamber device is shown, it is shown for illustration purposes only, and one of skill in the art could readily duplicate, eliminate or disable the appropriate circuitry in any desired combination to provide a device capable of treating the appropriate chamber(s) with the desired cardioversion, defibrillation and pacing stimulation.

ICTD 102 is shown schematically in FIG. 1B. Housing 140 is often referred to as the “can,” “case” or “case electrode” and may be programmably selected to act as the return electrode for all “unipolar” modes. Housing 140 may further be used as a return electrode alone or in combination with one or more of coil electrodes 118, 124, and 126 for shocking purposes. Housing 140 further includes a connector (not shown) having a plurality of terminals, 142, 144, 146, 148, 150, 152, 154, and 156 (shown schematically and, for convenience, the names of the electrodes to which they are connected are shown next to the terminals). As such, to achieve right atrial sensing and pacing, the connector includes at least a right atrial tip terminal (A_R TIP) 142 adapted for connection to atrial tip electrode 112.

To achieve left chamber sensing, pacing and shocking, the connector includes at least a left ventricular tip terminal (V_L TIP) 144, a left atrial ring terminal (A_L RING) 146, and a left atrial shocking terminal (A_L COIL) 148, which are adapted for connection to left ventricular ring electrode 114, left atrial tip electrode 116, and left atrial coil electrode 118, respectively.

To support right chamber sensing, pacing, and shocking the connector also includes a right ventricular tip terminal (V_R TIP) 150, a right ventricular ring terminal (V_R RING) 152, a right ventricular shocking terminal (RV COIL) 154, and an SVC shocking terminal (SVC COIL) 156, which are configured for connection to RV tip electrode 120, RV ring electrode 122, RV coil electrode 124, and SVC coil electrode 126, respectively.

At the core of ICTD 102 is a programmable microcontroller 160 which controls the various modes of stimulation therapy. As is well known in the art, microcontroller 160 typically includes a microprocessor, or equivalent control circuitry, designed specifically for controlling the delivery of stimulation therapy and can further include RAM or ROM memory, logic and timing circuitry, state machine circuitry, and I/O circuitry. Typically, microcontroller 160 includes the ability to process or monitor input signals (data) as controlled by a program code stored in a designated block of memory. The details of the design of microcontroller 160 are not critical to the present invention. Rather, any suitable microcontroller 160 can be used to carry out the functions described herein. The use of microprocessor-based control circuits for performing timing and data analysis functions are well known in the art. In a specific embodiment of the present invention, however, microprocessor 160 has an electroacoustic analysis circuitry block 162 for analyzing electroacoustic data.

Representative types of control circuitry that may be used with the invention include the microprocessor-based control system of U.S. Pat. No. 4,940,052 (Mann et al.) and the

state-machines of U.S. Pat. No. 4,712,555 (Thornander et al.) and U.S. Pat. No. 4,944,298 (Sholder). For a more detailed description of the various timing intervals used within the ICTD's and their inter-relationship, see U.S. Pat. No. 4,788,980 (Mann et al. et al.). The '052, '555, '298 and '980 patents are incorporated herein by reference.

As shown in FIG. 1B, an atrial pulse generator **170** and a ventricular pulse generator **172** generate pacing stimulation pulses for delivery by right atrial lead **106**, right ventricular lead **110**, and/or coronary sinus lead **108** via an electrode configuration switch **174**. It is understood that in order to provide stimulation therapy in each of the four chambers of the heart, atrial and ventricular pulse generators **170** and **172** may include dedicated, independent pulse generators, multiplexed pulse generators, or shared pulse generators. Pulse generators **170** and **172** are controlled by microcontroller **160** via appropriate control signals **176** and **178**, respectively, to trigger or inhibit the stimulation pulses. Power for the microcontroller **160**, as well as for the various pulse generators, is supplied by a battery **164**.

Microcontroller **160** further includes timing control circuitry **179** which is used to control pacing parameters (e.g., the timing of stimulation pulses) as well as to keep track of the timing of refractory periods, PVARP intervals, noise detection windows, evoked response windows, alert intervals, marker channel timing, etc., which are well known in the art. Examples of pacing parameters include, but are not limited to, atrio-ventricular (AV) delay, interventricular (RV-LV) interval, interatrial (RA-LA) interval, and pacing rate.

Switch **174** includes a plurality of switches for connecting the desired electrodes to the appropriate I/O circuits, thereby providing complete electrode programmability. Accordingly, switch **174**, in response to a control signal **180** from microcontroller **160**, determines the polarity of the stimulation pulses (e.g., unipolar, bipolar, combipolar, etc.) by selectively closing the appropriate combination of switches (not shown) as is known in the art.

Atrial sensing circuit **182** and ventricular sensing circuit **184** may also be selectively coupled to right atrial lead **106**, coronary sinus lead **108**, and right ventricular lead **110** through switch **174** for detecting the presence of cardiac activity in each of the four chambers of the heart. Accordingly, the atrial (ATR. SENSE) and ventricular (VTR. SENSE) sensing circuits **182** and **184** may include dedicated sense amplifiers, multiplexed amplifiers, or shared amplifiers. Switch **174** determines the "sensing polarity" of the cardiac signal by selectively closing the appropriate switches, as is also known in the art. In this way, a clinician may program the sensing polarity independent of the stimulation polarity.

Each sensing circuit **182** and **184** preferably employs one or more low power precision amplifiers with programmable gain and/or automatic gain control, bandpass filtering, and a threshold detection circuit, as known in the art, to selectively sense the cardiac signal of interest. The automatic gain control enables ICTD **102** to deal effectively with the difficult problem of sensing the low amplitude signal characteristics of atrial or ventricular fibrillation.

The outputs of atrial and ventricular sensing circuits **182** and **184** are connected to microcontroller **160** which, in turn, is able to trigger or inhibit atrial and ventricular pulse generators, **170** and **172**, respectively, in a demand fashion in response to the absence or presence of cardiac activity, in the appropriate chambers of the heart. Sensing circuits **182** and **184**, in turn, receive control signals over signal lines **186** and **188** from microcontroller **160** for purposes of measuring cardiac performance at appropriate times, and for control-

ling the gain, threshold, polarization charge removal circuitry (not shown), and timing of any blocking circuitry (not shown) coupled to the inputs of sensing circuits **182** and **186**.

For arrhythmia detection, ICTD **102** utilizes the atrial and ventricular sensing circuits **182** and **184** to sense cardiac signals to determine whether a rhythm is physiologic or pathologic. The timing intervals between sensed events (e.g., P-waves, R-waves, and depolarization signals associated with fibrillation which are sometimes referred to as "F-waves" or "Fib-waves") are then classified by microcontroller **160** by comparing them to a predefined rate zone limit (i.e., bradycardia, normal, low rate VT, high rate VT, and fibrillation rate zones) and various other characteristics (e.g., sudden onset, stability, physiologic sensors, morphology, etc.) in order to determine the type of remedial therapy that is needed (e.g., bradycardia pacing, anti-tachycardia pacing, cardioversion shocks or defibrillation shocks, collectively referred to as "tiered therapy"). According to the present invention, electroacoustic analysis provides an additional source of information for optimization of ICTD performance for arrhythmia therapy.

Microcontroller **160** utilizes arrhythmia detection circuitry **175** and morphology detection circuitry **176**, as well as, in the present invention, electroacoustic analysis circuitry **162**, to recognize and classify arrhythmias so that appropriate therapy can be delivered.

Cardiac signals are also applied to the inputs of an analog-to-digital (A/D) data acquisition system **190**. Data acquisition system **190** is configured to acquire intracardiac electrogram signals, convert the raw analog data into a digital signal, and store the digital signals for later processing and/or telemetric transmission to an external device **130**. Data acquisition system **190** is coupled to right atrial lead **106**, coronary sinus lead **108**, and right ventricular lead **110** through switch **174** to sample cardiac signals across any pair of desired electrodes.

Data acquisition system **190** can be coupled to microcontroller **160**, or other detection circuitry, for detecting an evoked response from heart **104** in response to an applied stimulus, thereby aiding in the detection of "capture." Capture occurs when an electrical stimulus applied to the heart is of sufficient energy to depolarize the cardiac tissue, thereby causing the heart muscle to contract. Microcontroller **160** detects a depolarization signal during a window following a stimulation pulse, the presence of which indicates that capture has occurred. Microcontroller **160** enables capture detection by triggering ventricular pulse generator **172** to generate a stimulation pulse, starting a capture detection window using timing control circuitry **179** within microcontroller **160**, and enabling data acquisition system **190** via control signal **192** to sample the cardiac signal that falls in the capture detection window and, based on the amplitude, determines if capture has occurred.

The implementation of capture detection circuitry and algorithms are well known. See for example, U.S. Pat. No. 4,729,376 (Decote, Jr.); U.S. Pat. No. 4,708,142 (Decote, Jr.); U.S. Pat. No. 4,686,988 (Sholder); U.S. Pat. No. 4,969,467 (Callaghan et al. et al.); and U.S. Pat. No. 5,350,410 (Kleks et al.), which patents are hereby incorporated herein by reference. The type of capture detection system used is not critical to the present invention.

Microcontroller **160** is further coupled to a memory **194** by a suitable data/address bus **196**, wherein the programmable operating parameters used by microcontroller **160** are stored and modified, as required, in order to customize the operation of ICTD **102** to suit the needs of a particular

patient. Such operating parameters define, for example, pacing pulse amplitude, pulse duration, electrode polarity, rate, sensitivity, automatic features, arrhythmia detection criteria, and the amplitude, waveshape and vector of each shocking pulse to be delivered to the patient's heart **104** within each respective tier of therapy.

The operating parameters of ICTD **102** may be non-invasively programmed into memory **194** through a telemetry circuit **132** in telemetric communication with external device **130**, such as a programmer, transtelephonic transceiver, or a diagnostic system analyzer. Telemetry circuit **132** is activated by microcontroller **160** by a control signal **134**. Telemetry circuit **132** allows intracardiac electrograms and status information relating to the operation of ICTD **102** (as contained in microcontroller **160** or memory **194**) to be sent to external device **130** through an established communication link **136**.

For examples of such devices, see U.S. Pat. No. 4,809,697, entitled "Interactive Programming and Diagnostic System for use with Implantable Pacemaker" (Causey, III et al.); U.S. Pat. No. 4,944,299, entitled "High Speed Digital Telemetry System for Implantable Device" (Silvian); and U.S. Pat. No. 6,275,734, entitled "Efficient Generation of Sensing Signals in an Implantable Medical Device such as a Pacemaker or ICD" (McClure et al.), which patents are hereby incorporated herein by reference.

Telemetry circuit **132** also allows optimization parameters obtained externally to be sent into microcontroller **160**. For example, in the present invention, electroacoustic data may be obtained by an external or transcutaneous electroacoustic device. That data may be assessed by a physician during a patient visit, and on the direction of the physician could be transmitted to microcontroller **160** for analysis and optimization of a number of parameters, as discussed below. Analysis may also be completed externally at a physician's office, with instructions based on the analysis transmitted to microcontroller **160**.

In an embodiment of the present invention, ICTD **102** further includes a biosensor **138** that can detect electroacoustic changes indicative of cardiac performance or changes in the physiological condition of the heart. ICTD **102** also includes electroacoustic analysis circuitry **162**. Electroacoustic analysis circuitry **162** can be implemented in hardware, software, or firmware. Electroacoustic analysis circuitry **162** may be located in microcontroller **160**, as depicted, or it can be separate from microcontroller **160**. Accordingly, microcontroller **160** can respond by adjusting the various pacing parameters (such as rate, AV Delay, RV-LV interval, etc.) in accordance with the embodiments of the present invention. Microcontroller **160** controls adjustments of pacing parameters by, for example, controlling the stimulation pulses generated by the atrial and ventricular pulse generators **170** and **172**. While shown in FIG. 1A as being included within ICTD **102**, one skilled in the art will recognize that biosensor **138** may also be external to ICTD **102** while implanted within or carried by a patient and still send information to microcontroller **160**. More specifically, biosensor **138** can be located inside ICTD **102**, on the surface of ICTD **102**, in a header of ICTD **102**, on a lead (which can be placed inside or outside the bloodstream), or otherwise separated from ICTD **102**. Further details on possible locations for biosensor **138** will be discussed below with respect to FIG. 4.

ICTD **102** further includes a magnet detection circuitry (not shown), coupled to microcontroller **160**. It is the purpose of the magnet detection circuitry to detect when a magnet is placed over ICTD **102**, which magnet may be used

by a clinician to perform various test functions of ICTD **102** and/or to signal microcontroller **160** that the external programmer **130** is in place to receive or transmit data to microcontroller **160** through telemetry circuit **132**.

As further shown in FIG. 1B, ICTD **102** includes an impedance measuring circuit **166** which is enabled by microcontroller **160** via a control signal **168**. The known uses for an impedance measuring circuit **166** include, but are not limited to, lead impedance surveillance during the acute and chronic phases for proper lead positioning or dislodgement; detecting operable electrodes and automatically switching to an operable pair if dislodgement occurs; measuring respiration or minute ventilation; measuring thoracic impedance for determining shock thresholds; detecting when the device has been implanted; measuring stroke volume; and detecting the opening of heart valves, etc. The impedance measuring circuit **166** is advantageously coupled to switch **174** so that any desired electrode may be used. The impedance measuring circuit **166** is not critical to the present invention and is shown only for completeness.

In the case where ICTD **102** is intended to operate as a cardioverter, pacer or defibrillator, it must detect the occurrence of an arrhythmia and automatically apply an appropriate electrical therapy to the heart aimed at terminating the detected arrhythmia. To this end, microcontroller **160** further controls a shocking circuit **161** by way of a control signal **163**. The shocking circuit **161** generates shocking pulses of low (up to 0.5 Joules), moderate (0.5-10 Joules), or high energy (11 to 40 Joules), as controlled by microcontroller **160**. Such shocking pulses are applied to the patient's heart **104** through at least two shocking electrodes (e.g., selected from left atrial coil electrode **118**, RV coil electrode **124**, and SVC coil electrode **126**). As noted above, housing **140** may act as an active electrode in combination with RV electrode **124**, or as part of a split electrical vector using SVC coil electrode **126** or left atrial coil electrode **118** (i.e., using the RV electrode as a common electrode).

Cardioversion shocks are generally considered to be of low to moderate energy level (so as to minimize pain felt by the patient), and/or synchronized with an R-wave and/or pertaining to the treatment of tachycardia. Defibrillation shocks are generally of moderate to high energy level (i.e., corresponding to thresholds in the range of 5-40 Joules), delivered asynchronously (since R-waves may be too disorganized to be recognize), and pertaining exclusively to the treatment of fibrillation. Accordingly, microcontroller **160** is capable of controlling the synchronous or asynchronous delivery of the shocking pulses.

B. Electroacoustics

FIG. 2A illustrates how the ions in a colloid organize themselves relative to a suspended particle **200**. FIG. 2A shows particle **200** in a steady state. Particle surface **202** is represented by the innermost ring. Because of the affinity of ions for a surface, an electric surface charge builds up and creates an electrostatic field. Alternatively, the surface charge of the particle may be fixed. See, A. S. Dukhin & P. J. Goetz, *Ultrasound for Characterizing Colloids: Particle Sizing, Zeta Potential, Rheology* (Elsevier 2002), hereby incorporated by reference herein in its entirety. This electrostatic field affects ions in the liquid surrounding particle **200**. This draws ions in the liquid toward the particle and results in what is referred to as a "double layer". The first layer of the double layer is particle surface **202**. The second layer **208** is made up of oppositely charged ions from the

surrounding liquid held in close association to the ions in the particle. The outer boundary of the double layer is the shear plane **204**.

FIG. 2B shows the effect of an acoustic or time-varying electric assaulting field on particle **200**. Before the assaulting field is applied, at time $t=0$, the double layer of particle **200** is in a steady state arrangement, or equilibrium. In response to the assaulting field, the charged particle and the surrounding double layer are displaced relative to their mass/density. The difference in density between them disrupts the double layer. A representation of this shift is shown as disrupted particle **206**. When the assaulting field is removed, the molecules in second layer **208** return to the steady state arrangement. This movement of molecules returning to steady state emits a resultant field which can be detected. If the assaulting field is acoustic, the resultant field is electric. Likewise, if the assaulting field is electric, the resultant field is acoustic.

C. Biosensor

Biosensor **138** is configured to transmit and detect acoustic and/or electric energy. An ultrasound probe used in inorganic colloidal chemistry is described in Dukhin & Goetz, pp. 235-237. The biosensor of the present invention utilizes a probe similar to that described in Dukhin & Goetz. Although the present invention will be described with reference to the probe discussed in Dukhin & Goetz, it will be apparent to one skilled in the art that other probes with different geometries and dimensions for detecting colloidal concentrations may be used. Other example probes for use in the present invention are the DT300, DT100, and DT1200 manufactured by Dispersion Technology, Inc., of Bedford Hills, N.Y., which produce an acoustic field and measure an electric field, and the ESA9800 manufactured by Matec Applied Sciences, of Northborough, Mass., which produces an electric field and measures an acoustic field.

FIG. 3A is a block diagram of an exemplary probe **300**. A transmitting portion of probe **300** includes a transducer **302**, connected to cable connector **304** and input cable **306**. In an embodiment, cable connector **304** is a UHF cable connector. In an embodiment, transducer **302** includes a cylindrical piezoelectric device **308** having a front electrode **310** and a back electrode **312** across which an RF pulse can be applied to generate an acoustic assaulting pulse. A person of ordinary skill in the art will recognize, however, that other types of transducers may be used, such as transducers with non-piezoelectric materials or transducers of varying sizes and shapes. Further, although FIG. 3A is described herein with reference to generation of an acoustic assaulting field, one skilled in the art will recognize that a similar device may be employed to generate an electric assaulting field. Front electrode **310** and back electrode **312** of piezoelectric device **308** are connected to corresponding terminals of connector **304** by means of internal jumper wires **314** in a manner well known to those skilled in the art. Piezoelectric device **308** in turn is bonded to a delay rod **316** by means of a suitable adhesive. In an embodiment, delay rod **316** is formed out of quartz.

The resonant frequency of piezoelectric device **308** is selected depending on the frequency range for which electroacoustic data is desired. The present invention detects electroacoustic data for organic compounds such as, for example, proteins, suspended in a liquid such as, for example, blood. In an embodiment, in order to provide an appropriate range for each protein of interest, the present

invention scans within a frequency range of about 0.5 MHz to 100 MHz. In another embodiment, the frequency range is about 0.9 MHz to 1.2 MHz.

Delay rod **316** of probe **300** is extended by an additional buffer rod **318** having an acoustic impedance that is closely matched to that of the colloid. Transducer **302** and buffer rod **318** are cemented together and inserted into a ceramic spacer **320** until buffer rod **318** aligns with a shoulder **322** on spacer **320**.

In an embodiment, the end of buffer rod **318** is coated with gold in order to provide an electrode for measuring the electrical response of the colloid when excited acoustically. This electrical response is also referred to herein as the resultant field. FIG. 3B provides an end view of probe **300** showing the relative location of gold electrode **324**, spacer **320**, and a casing **326**.

A coaxial cable **328** detects the resultant field once the assaulting field is turned off. In an embodiment where the assaulting field is an acoustic field, the resultant field is detected as a colloid vibration current ("CVI") signal. In another embodiment, where the assaulting field is an electric field, the resultant field is detected as an electrosonic amplitude ("ESA") signal. When probe **300** comes in contact with the colloid, the signal between gold electrode **324** and the surrounding casing **326** is thus available at the output of coaxial cable **328**.

In an embodiment, biosensor **138** is an implantable biosensor controlled by electroacoustic analysis circuitry **162** in ICTD **102**. Biosensor **138** may be implanted in one of several locations. In one embodiment, biosensor **138** is implanted in the vicinity of a blood vessel in the body and generates an electric or acoustic assaulting field directed at that blood vessel. In another embodiment, biosensor **138** is implanted in interstitial fluid.

FIG. 4 illustrates example locations for biosensor **138** (not shown to scale) with respect to ICTD **102**. In one embodiment, biosensor **138** is connected at location **402** to the surface of a lead of ICTD **102**, such as leads **106**, **108**, or **110**. In another embodiment, biosensor **138** is attached at location **404** to housing **140** of ICTD **102**. In yet another embodiment, biosensor **138** is placed at location **406** in extravascular space outside a blood vessel, and is connected to ICTD **102** through connecting wires or transmission lines **408**. Alternatively, biosensor **138** may transmit information to ICTD **102** wirelessly.

Biosensor **138** may also interact transcutaneously with substances in the body. In this embodiment, biosensor **138** transmits an assaulting field through the skin from an external location to disrupt a colloid in the body. In another embodiment, biosensor **138** is a standalone sensor used to detect substances in biological liquids. For example, biosensor **138** can be used to detect protein levels in a blood sample.

FIG. 5 is a flowchart of a method **500** used in the present invention. In step **502**, an assaulting field is produced either in vivo or transcutaneously. In one embodiment, the assaulting field is an acoustic field. In another embodiment, the assaulting field is an electric field. The frequency of the assaulting field is chosen based on the properties of the substance of interest. In one embodiment, the substance of interest is the protein ANP and/or BNP. In another embodiment, the substance of interest is at least one of the following: C-reactive protein, CK-MB, Troponin I, Troponin T, Troponin C, or myoglobin. One or more protein concentrations may be sought after at one time. The assaulting field may be directed at the substance in a blood vessel, or at the substance in interstitial fluid. As described above with

respect to FIG. 2B, the assaulting field disrupts the double layer of particles in the direction of the field.

In step 504, the assaulting field is removed. At this point, the ions reassemble the double layer and give off an in vivo resultant field proportional to the energy required for the initial disruption of the ions. This resultant field is measured in step 506.

In step 508, the concentration of the substance of interest is determined based on the resultant field measured in step 506. In an embodiment, the measurements of the resultant field are transmitted to the electroacoustic analysis circuitry 162, for determination by the ICTD 102. In another embodiment, the measurements are transmitted to external device 130 to determine the concentration.

Method 500 may also be used for an external biosensor. In this embodiment, the assaulting field is directed in step 502 toward proteins in an external blood sample. All other steps in method 500 remain the same.

In an embodiment, method 500 is repeated continuously. In another embodiment, method 500 is repeated periodically. In yet another embodiment, the repeat cycle of method 500 is synchronized to the cardiac cycle to account for changes in cross-sectional area of the vessel. In another embodiment, the repeat cycle of method 500 is synchronized to the respiratory cycle to account for subtle changes in blood pH which influence the isoelectric potential of proteins. In still another embodiment, the repeat cycle of method 500 is synchronized to an activity sensor to account for motion and greater change in blood pH as O₂ and CO₂ levels shift during maximal exercise. Method 500 may be used as a monitoring technique by clinicians, wherein the relative levels of substances in the blood are indicative of cardiac health.

FIG. 6 is a flowchart of a method 600, wherein an additional step is added to method 500. In step 602, a cardiac threat is detected based on changes in the concentration of the substance of interest. For example, concentration levels of BNP and/or ANP can provide early warning of an impending heart failure exacerbation. Alternatively, concentration levels of C-reactive protein, CK-MB, Troponin I, Troponin T, Troponin C, and/or myoglobin can provide early warning of a myocardial ischemia and impending arrhythmia.

Step 602 is performed by an interpreter, such as, for example, microcontroller 160. In an embodiment, microcontroller 160 performs step 602 by interpreting data from biosensor 138. For example, microcontroller 160 can compare protein concentrations to one or more predetermined thresholds and then take action based on the results of the comparisons. In this embodiment, if a cardiac threat has developed, ICTD 102 may be able to initiate therapy based on the data received. In another embodiment, an external device or clinician may perform step 602.

D. Experimental Results

FIG. 7 is a graph of test results obtained when using an acoustic assaulting field from a stand-alone Dispersion Technologies device to detect levels of albumin in deionized water. The assaulting field had a field strength of 10 mW and a frequency of 3 MHz. The albumin slowly dissolved into the deionized water as the water was warmed. Several samples of varying concentrations were taken. These concentrations are shown on horizontal axis 702. A uniform acoustic field was applied to all samples. The magnitude of the electric resultant field detected (i.e., colloidal vibration current or CVI) is shown on vertical axis 704. As shown by the various data points, the detected CVI changed as the colloidal composition changed.

Each of FIGS. 8-11 displays results from tests in which the assaulting field was a time-varying electric field created by a stand-alone Matec Applied Sciences device. The sinusoidal electric field had a field strength of approximately 66 V/mm and a frequency of approximately 1 MHz. The process of testing samples was analogous to the process described with respect to FIG. 7. In each figure, the varying concentrations of the colloid are displayed on the horizontal axis, with the magnitude of the corresponding acoustic resultant field (e.g., ESA) on the vertical axis. The assaulting field was constant for testing all samples of each colloid. FIG. 8 displays ESA magnitude resulting from various concentrations of Fibrinogen in saline. FIG. 9 displays ESA magnitude resulting from various concentrations of albumin in saline. FIGS. 10 and 11 display ESA magnitude resulting from two separate tests of various concentrations of albumin in deionized water. The results of the tests in FIG. 10 and FIG. 11 are very similar, which shows the accuracy of the method. As shown in FIGS. 8-11, the magnitude of the resultant field varies nearly linearly with concentration.

While various embodiments of the present invention have been described above, it should be understood that they have been presented by way of example only, and not limitation. It will be apparent to persons skilled in the relevant art that various changes in form and detail can be made therein without departing from the spirit and scope of the invention. Thus, the breadth and scope of the present invention should not be limited by any of the above-described exemplary embodiments, but should be defined only in accordance with the following claims and their equivalents.

What is claimed is:

1. A method of monitoring a concentration of suspended particles in a biomedical colloid comprising:
 - a. producing an assaulting acoustic field;
 - b. measuring a resultant electric field produced in vivo by particle interaction with the assaulting field; and
 - c. determining the concentration of the suspended particles based on the measured resultant field.
2. The method of claim 1, wherein said biomedical colloid is blood.
3. The method of claim 1, wherein said biomedical colloid is interstitial fluid.
4. The method of claim 1, wherein said suspended particles are proteins.
5. The method of claim 4, further comprising:
 - d. assessing a cardiac threat based on the concentration of the suspended proteins.
6. The method of claim 5, wherein said suspended proteins include at least one of the group consisting of BNP and ANP.
7. The method of claim 6, wherein said cardiac threat is heart failure exacerbation.
8. The method of claim 5, wherein said suspended proteins comprise at least one protein selected from the group consisting of C-reactive protein, CK-MB, ischemia-modified albumin, Troponin I, Troponin T, Troponin C, and myoglobin.
9. The method of claim 8, wherein said cardiac threat is at least one of myocardial ischemia and myocardial damage.
10. The method of claim 5, further comprising:
 - e. performing cardiac therapy based on the cardiac threat determined in step (d).
11. The method of claim 1, wherein a frequency of said assaulting acoustic field is determined based on properties of the suspended particles.

13

12. The method of claim 1, further including the step of monitoring changes in the concentration of the suspended particles over time.

13. A method of monitoring a concentration of suspended proteins in a biomedical colloid, comprising:

- a. producing an assaulting field;
- b. measuring a resultant field produced by particle interaction with the assaulting field, wherein one of said assaulting field and said resultant field is an electric field; and
- c. determining the concentration of suspended proteins based on the measured resultant field.

14. The method of claim 13, wherein said biomedical colloid is blood.

15. The method of claim 13, wherein said biomedical colloid is interstitial fluid.

16. The method of claim 13, further comprising:

- d. detecting a cardiac threat based on the concentration of the suspended proteins.

17. The method of claim 16, further comprising:

- e. performing cardiac therapy based on the cardiac threat determined in step (d).

18. The method of claim 13 wherein the other of said assaulting field and said resultant field is an acoustic field.

19. An implantable cardiac therapy device including an implantable biosensor for monitoring a concentration of suspended particles in a biomedical colloid, said implantable biosensor comprising:

- a generator configured to produce an assaulting acoustic field in vivo;
- a transmitter configured to transmit the assaulting acoustic field; and
- a receiver configured to detect a resultant electric field produced in vivo by particle interaction with the assaulting acoustic field, said resultant field being indicative of the concentration of suspended particles.

20. The implantable cardiac therapy device of claim 19, wherein said suspended particles are proteins, and wherein said biomedical colloid is blood.

21. The implantable cardiac therapy device of claim 19, wherein said biomedical colloid is interstitial fluid.

22. The implantable cardiac therapy device of claim 19, wherein said implantable biosensor is configured for implantation in close proximity to a blood vessel.

23. The implantable cardiac therapy device of claim 19, further comprising:

- a processor configured to calculate a concentration of proteins in the biomedical colloid.

24. The implantable cardiac therapy device of claim 23, further comprising:

- an interpreter configured to detect a cardiac threat based on the concentration of proteins.

25. An implantable cardiac therapy device comprising: means for producing a first signal, said first signal causing an implantable biosensor to transmit an assaulting field

14

into a biomedical colloid, said assaulting field causing said biomedical colloid to produce a resultant field;

means for receiving a second signal representative of said resultant field, wherein one of said assaulting field and said resultant field is an electric field; and

means for processing said second signal to produce a value indicative of a concentration of suspended particles in said biomedical colloid.

26. The implantable cardiac therapy device of claim 25, further comprising:

means for adjusting a pacing parameter based on said value.

27. The implantable cardiac therapy device of claim 25, wherein said biomedical colloid is blood, wherein said second signal is representative of a concentration of suspended proteins in blood, and wherein said processing means is configured to produce a value indicative of a concentration of suspended proteins in said blood.

28. The implantable cardiac therapy device of claim 27, further comprising:

means for adjusting a pacing parameter based on said value.

29. The device of claim 25 wherein the other of said assaulting field and said resultant field is an acoustic field.

30. A method of monitoring a concentration of suspended particles in a biomedical colloid comprising:

- a. producing an assaulting electric field;
- b. measuring a resultant field produced in vivo by particle interaction with the assaulting field; and
- c. determining the concentration of the suspended particles based on the measured resultant field.

31. The method of claim 30 wherein the resultant field is an acoustic field.

32. The method of claim 30 and further including the step of storing the determined concentration in a memory.

33. An implantable cardiac therapy device including an implantable biosensor for monitoring a concentration of suspended particles in a biomedical colloid, said implantable biosensor comprising:

- a generator configured to produce an assaulting field in vivo;
- a transmitter configured to transmit the assaulting field; and

a receiver configured to detect a resultant field produced in vivo by particle interaction with the assaulting field, said resultant field being indicative of the concentration of suspended particles, wherein one of said assaulting field and said resultant field is an electric field.

34. The device of claim 33 wherein the other of said assaulting field and said resultant field is an acoustic field.

* * * * *

专利名称(译)	植入式生物传感器和监测心脏健康的方法		
公开(公告)号	US7223237	公开(公告)日	2007-05-29
申请号	US10/830850	申请日	2004-04-22
[标]申请(专利权)人(译)	SHELCHUK ANNE中号		
申请(专利权)人(译)	SHELCHUK ANNE中号		
当前申请(专利权)人(译)	PACESETTER , INC.		
[标]发明人	SHELCHUK ANNE M		
发明人	SHELCHUK, ANNE M.		
IPC分类号	A61B5/00 A61B5/08 A61B8/08 A61N1/362 A61N1/365		
CPC分类号	A61B5/0538 A61B5/145 A61B5/14546 A61N1/3622 A61N1/3627 A61N1/36528 A61B5/00 A61B5/0809 A61B8/08		
代理机构(译)	MITCHELL , 史蒂芬M.		
其他公开文献	US20050240088A1		
外部链接	Espacenet USPTO		

摘要(译)

连续监测多种血液传播物质(例如蛋白质)中任何一种的浓度的能力通过早期检测心脏威胁改善了患者监测和整体护理。在分析化学中用于确定悬浮在胶体组合物中的颗粒量的基于超声的技术可以用于可植入传感器中以监测血液中许多不同物质的水平。传感器系统植入体内血管中或附近,并产生指向该血管的电场或声场。发生器附近的接收器检测一旦攻击场被关闭后发出的能量。被监测物质的相对量的变化表现为一旦冲击场被移除后发射的能量的变化。传感器可以在可植入心脏治疗设备中实现。非植入式或经皮传感器也可用于监测心脏健康。

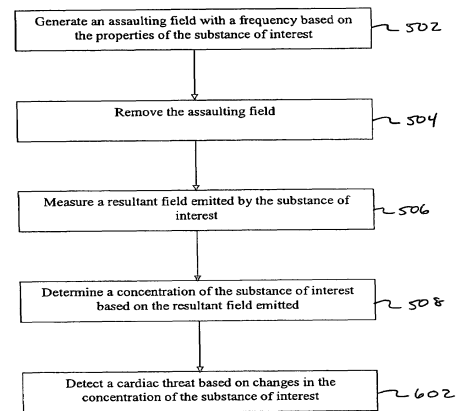

600 ↗