



US 20090036756A1

(19) **United States**

(12) **Patent Application Publication**
Pradeep et al.

(10) **Pub. No.: US 2009/0036756 A1**
(43) **Pub. Date: Feb. 5, 2009**

(54) **NEURO-RESPONSE STIMULUS AND STIMULUS ATTRIBUTE RESONANCE ESTIMATOR**

Related U.S. Application Data

(60) Provisional application No. 60/952,723, filed on Jul. 30, 2007.

(75) Inventors: **Anantha Pradeep**, Berkeley, CA (US); **Robert T. Knight**, Berkeley, CA (US); **Ramachandran Gurumoorthy**, Berkeley, CA (US)

Publication Classification

(51) **Int. Cl.**
A61B 5/0484 (2006.01)
A61B 5/00 (2006.01)
(52) **U.S. Cl.** **600/301; 600/544; 128/898**
(57) **ABSTRACT**

Correspondence Address:
Weaver Austin Villeneuve & Sampson LLP
P.O. BOX 70250
OAKLAND, CA 94612-0250 (US)

A system determines neuro-response stimulus and stimulus attribute resonance. Stimulus material and stimulus material attributes such as communication, concept, experience, message, images, audio, pricing, and packaging are evaluated using neuro-response data collected with mechanisms such as Event Related Potential (ERP), Electroencephalography (EEG), Galvanic Skin Response (GSR), Electrocardiograms (EKG), Electrooculography (EOG), eye tracking, and facial emotion encoding. Neuro-response data is analyzed to determine stimulus and stimulus attribute resonance.

(73) Assignee: **NEUROFOCUS, INC.**, Berkeley, CA (US)

(21) Appl. No.: **12/182,874**

(22) Filed: **Jul. 30, 2008**

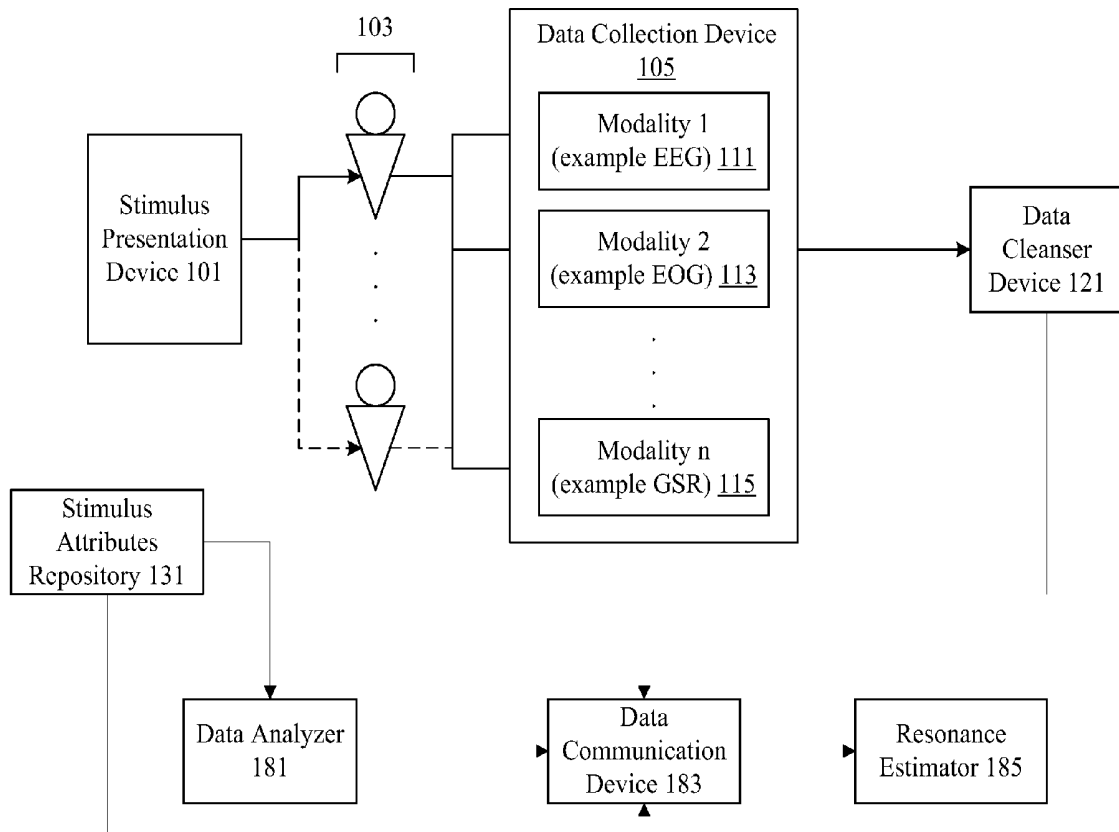

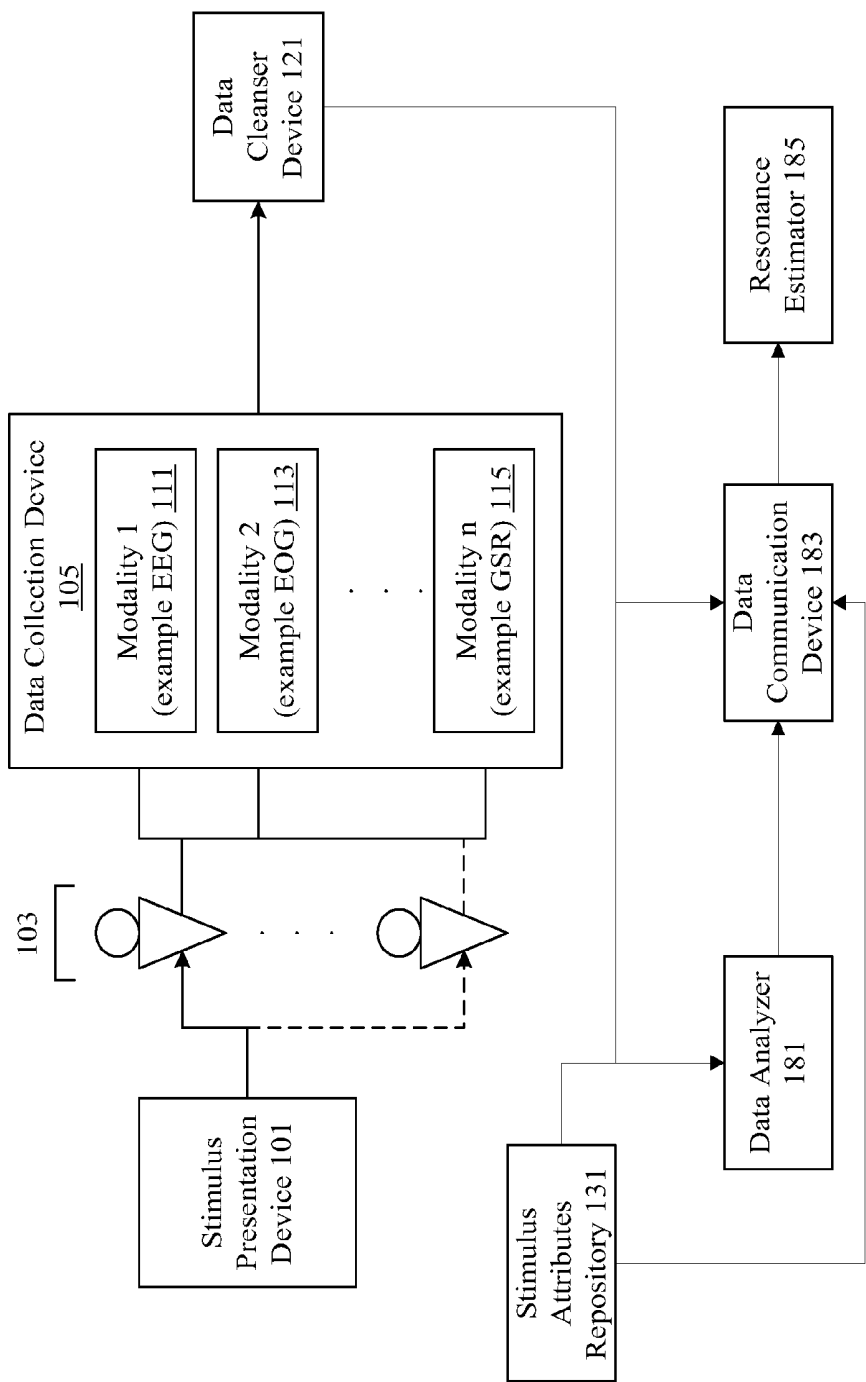

Figure 1

Stimulus Attributes Data Model 201			
Channel 203	Media 205	Time Span 207	Audience 209
			Demography 211
			...

Stimulus Purpose Data Model 215	
Intent 217	Objectives 219
	Entity Temporal And Spatial Information 221
	...

Stimulus Attributes Data Model 221		
Creation Attributes 223	Ownership Attributes 225	Broadcast Attributes 227
		Statistical, Demographic, And Survey Based Identifiers 229
		...

Figure 2

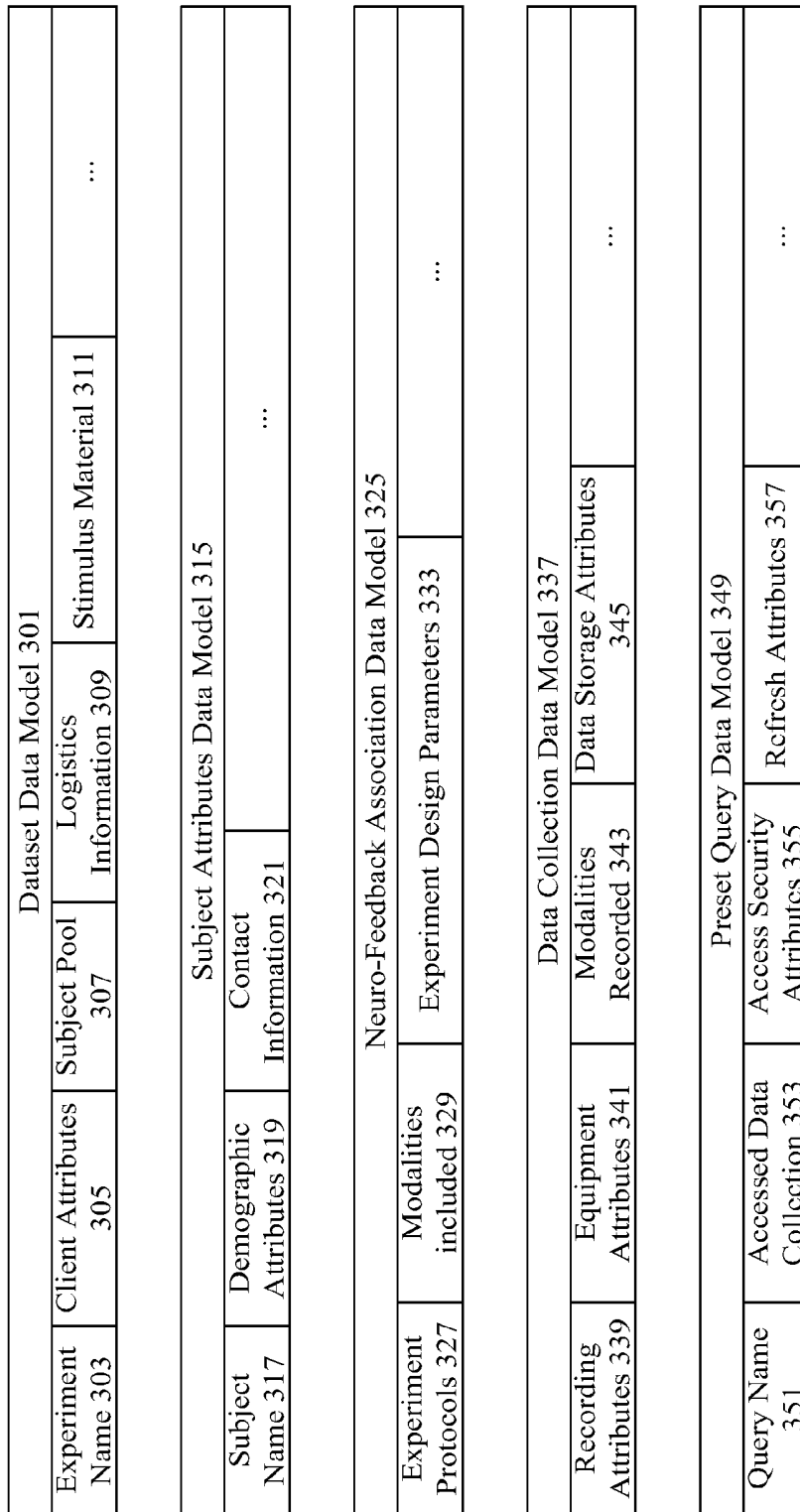

Figure 3

Subject Attributes Queries 415		
Location 417	Demographic Attributes 419	Session Information 421 ...
Experimental Design Queries 425		
Experiment Protocols 427	Product Category 429	Surveys Included 431 Stimulus Used 433 ...
Response Assessment Queries 437		
Attention Score 439	Emotion Score 441	Retention Score 443 Effectiveness Score 445 ...

Figure 4

Client Assessment Summary Reports 501			
Effectiveness 503	Component Assessment 505	Resonance Measures 507	...
Client Cumulative Reports 511			
Media Grouped 513	Campaign Grouped 515	Time/Location Grouped 517	...
Industry Cumulative And Syndicated Reports 521			
Aggregate Assessment 523	Top Performers 525	Bottom Performers 527	Outliers 529 Trend 531 ...

Figure 5

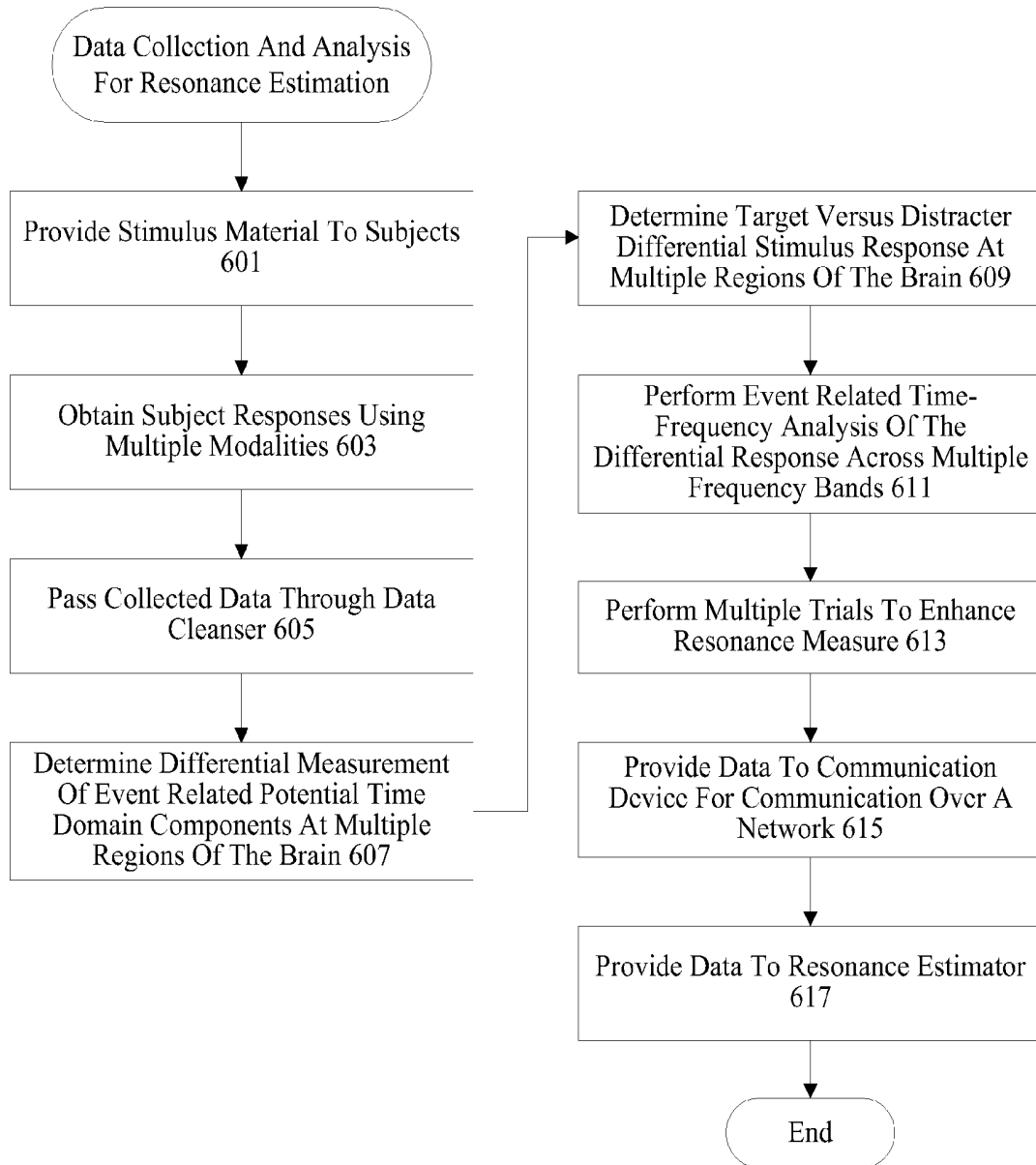

Figure 6

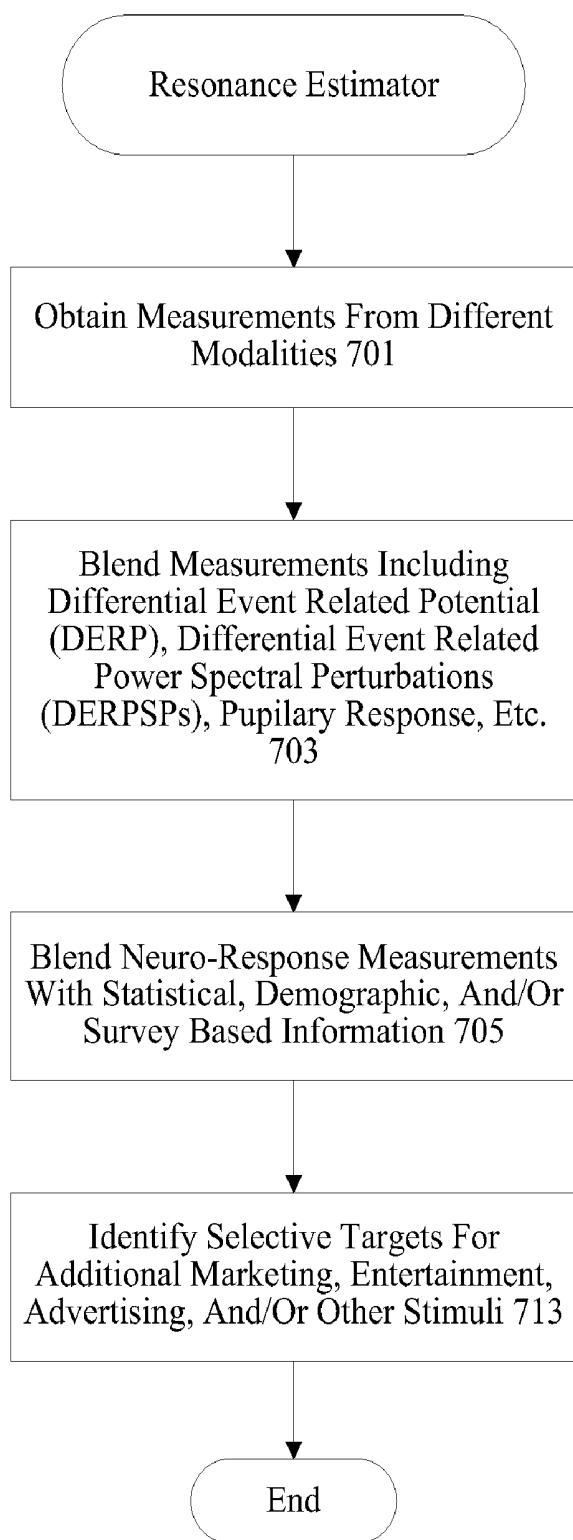

Figure 7

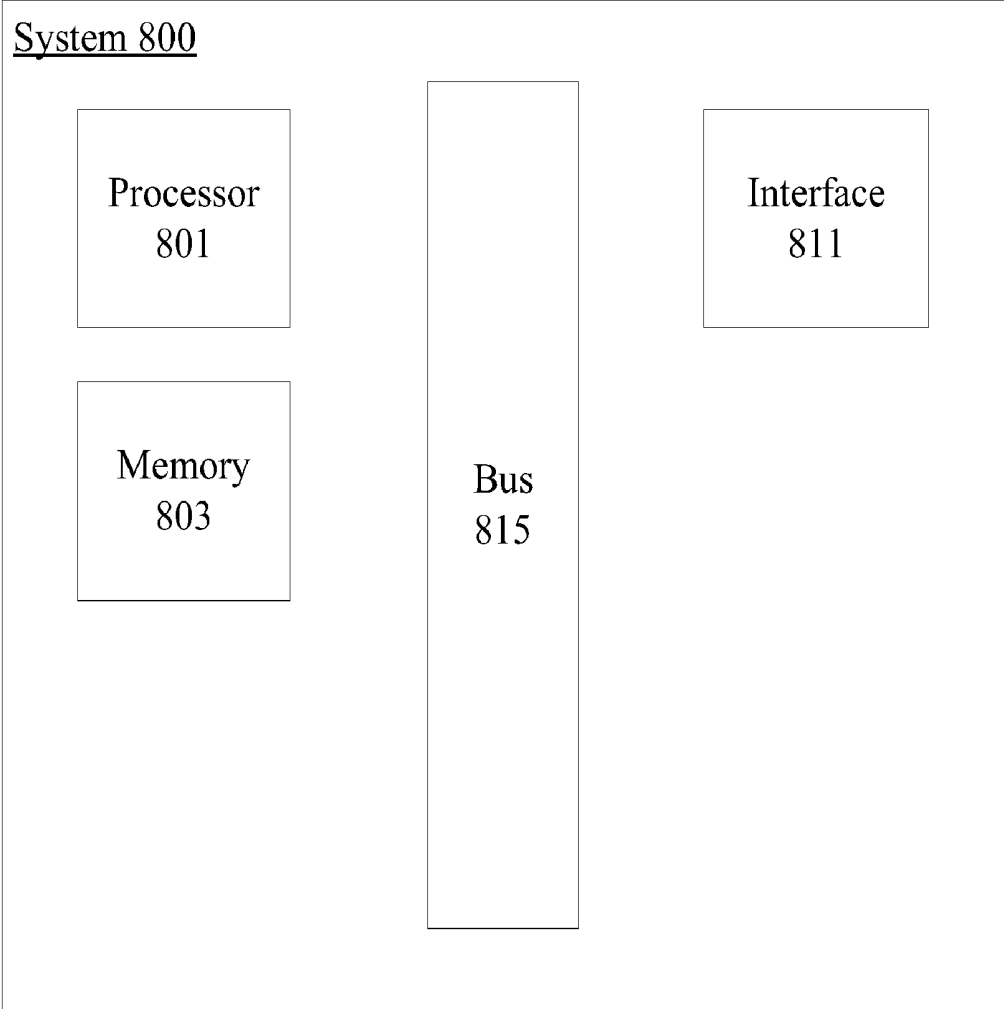

Figure 8

NEURO-RESPONSE STIMULUS AND STIMULUS ATTRIBUTE RESONANCE ESTIMATOR

CROSS REFERENCE TO RELATED APPLICATIONS

[0001] This application claims priority to Provisional Patent Application 60/952,723, (Docket No. 2007NF12) titled Neuro-Physiological And Neuro-Behavioral Stimulus And Stimulus Attribute Resonance Estimator, by Anantha Pradeep, Robert T. Knight, and Ramachandran Gurumoorthy, and filed on Jul. 30, 2007.

TECHNICAL FIELD

[0002] The present disclosure relates to a stimulus and stimulus attribute resonance estimator.

DESCRIPTION OF RELATED ART

[0003] Conventional systems for estimating stimulus and stimulus attribute resonance are limited. Some audience resonance measurement systems are based on demographic information, statistical data, and survey based response collection. However, conventional systems are subject to semantic, syntactic, metaphorical, cultural, and interpretive errors.

[0004] Consequently, it is desirable to provide improved methods and apparatus for estimating stimulus and stimulus attribute resonance.

BRIEF DESCRIPTION OF THE DRAWINGS

[0005] The disclosure may best be understood by reference to the following description taken in conjunction with the accompanying drawings, which illustrate particular example embodiments.

[0006] FIG. 1 illustrates one example of a system for estimating stimulus and stimulus attribute resonance.

[0007] FIG. 2 illustrates examples of stimulus attributes that can be included in a stimulus attributes repository.

[0008] FIG. 3 illustrates examples of data models that can be used with a stimulus and response repository.

[0009] FIG. 4 illustrates one example of a query that can be used with the resonance estimation system.

[0010] FIG. 5 illustrates one example of a report generated using the resonance estimation system.

[0011] FIG. 6 illustrates one example of a technique for performing data analysis.

[0012] FIG. 7 illustrates one example of technique for estimating stimulus and stimulus attribute resonance.

[0013] FIG. 8 provides one example of a system that can be used to implement one or more mechanisms.

DESCRIPTION OF PARTICULAR EMBODIMENTS

[0014] Reference will now be made in detail to some specific examples of the invention including the best modes contemplated by the inventors for carrying out the invention. Examples of these specific embodiments are illustrated in the accompanying drawings. While the invention is described in conjunction with these specific embodiments, it will be understood that it is not intended to limit the invention to the described embodiments. On the contrary, it is intended to cover alternatives, modifications, and equivalents as may be

included within the spirit and scope of the invention as defined by the appended claims.

[0015] For example, the techniques and mechanisms of the present invention will be described in the context of particular types of data such as central nervous system, autonomic nervous system, and effector data. However, it should be noted that the techniques and mechanisms of the present invention apply to a variety of different types of data. It should be noted that various mechanisms and techniques can be applied to any type of stimuli. In the following description, numerous specific details are set forth in order to provide a thorough understanding of the present invention. Particular example embodiments of the present invention may be implemented without some or all of these specific details. In other instances, well known process operations have not been described in detail in order not to unnecessarily obscure the present invention.

[0016] Various techniques and mechanisms of the present invention will sometimes be described in singular form for clarity. However, it should be noted that some embodiments include multiple iterations of a technique or multiple instantiations of a mechanism unless noted otherwise. For example, a system uses a processor in a variety of contexts. However, it will be appreciated that a system can use multiple processors while remaining within the scope of the present invention unless otherwise noted. Furthermore, the techniques and mechanisms of the present invention will sometimes describe a connection between two entities. It should be noted that a connection between two entities does not necessarily mean a direct, unimpeded connection, as a variety of other entities may reside between the two entities. For example, a processor may be connected to memory, but it will be appreciated that a variety of bridges and controllers may reside between the processor and memory. Consequently, a connection does not necessarily mean a direct, unimpeded connection unless otherwise noted.

[0017] Overview

[0018] A system determines neuro-response stimulus and stimulus attribute resonance. Stimulus material and stimulus material attributes such as communication, concept, experience, message, images, audio, pricing, and packaging are evaluated using neuro-response data collected with mechanisms such as Event Related Potential (ERP), Electroencephalography (EEG), Galvanic Skin Response (GSR), Electrocardiograms (EKG), Electrooculography (EOG), eye tracking, and facial emotion encoding. Neuro-response data is analyzed to determine stimulus and stimulus attribute resonance.

Example Embodiments

[0019] Stimulus and stimulus attribute resonance estimators have been in use for years. Typically, stimulus and stimulus attribute resonance estimators are based on audience resonance measurement systems that typically rely on demographic information, statistical information, and survey based response collection. One problem with conventional stimulus and stimulus attribute resonance estimators is that conventional resonance estimators do not measure the inherent message resonance that is attributable to the stimulus. They are also prone to semantic, syntactic, metaphorical, cultural, and interpretive errors thereby preventing the accurate and repeatable targeting of the audience.

[0020] Conventional systems do not use neuro-behavioral and neuro-physiological response blended manifestations in

assessing the user response and do not elicit an individual customized neuro-physiological and/or neuro-behavioral response to the stimulus.

[0021] Conventional devices also fail to blend multiple datasets, and blended manifestations of multi-modal responses, across multiple datasets, individuals and modalities, to reveal and validate the elicited measures of preference and resonance to stimulus and stimulus attributes

[0022] In these respects, the neuro-physiological and neuro-behavioral stimulus and stimulus attribute resonance estimator according to the present invention substantially departs from the conventional concepts and designs of the prior art, and in so doing provides an apparatus primarily developed for the purpose of providing a method and a system for the neuro-physiological and neuro-behavioral response based measurement of audience response and resonance to attributes of marketing, advertising and other audio/visual/tactile/olfactory stimulus including but not limited to communication, concept, experience, message, images, audio, pricing, packaging.

[0023] The techniques and mechanisms of the present invention use neuro-response measurements such as central nervous system, autonomic nervous system, and effector measurements to improve resonance estimation. Some examples of central nervous system measurement mechanisms include Functional Magnetic Resonance Imaging (fMRI) and Electroencephalography (EEG). fMRI measures blood oxygenation in the brain that correlates with increased neural activity. However, current implementations of fMRI have poor temporal resolution of few seconds. EEG measures electrical activity associated with post synaptic currents occurring in the milliseconds range. Subcranial EEG can measure electrical activity with the most accuracy, as the bone and dermal layers weaken transmission of a wide range of frequencies. Nonetheless, surface EEG provides a wealth of electrophysiological information if analyzed properly. Even portable EEG with dry electrodes provide a large amount of neuro-response information.

[0024] Autonomic nervous system measurement mechanisms include Galvanic Skin Response (GSR), Electrocardiograms (EKG), pupillary dilation, etc. Effector measurement mechanisms include Electrooculography (EOG), eye tracking, facial emotion encoding, reaction time etc.

[0025] According to various embodiments, the techniques and mechanisms of the present invention intelligently blend multiple modes and manifestations of precognitive neural signatures with cognitive neural signatures and post cognitive neurophysiological manifestations to more accurately perform resonance estimation. In some examples, autonomic nervous system measures are themselves used to validate central nervous system measures. Effector and behavior responses are blended and combined with other measures. According to various embodiments, central nervous system, autonomic nervous system, and effector system measurements are aggregated into a measurement that allows determination of stimulus and stimulus attribute resonance.

[0026] In particular embodiments, subjects are exposed to stimulus material and data such as central nervous system, autonomic nervous system, and effector data is collected during exposure. According to various embodiments, data is collected in order to determine a resonance measure that aggregates multiple component measures that assess resonance data. In particular embodiments, specific event related potential (ERP) analyses and/or event related power spectral

perturbations (ERPSPs) are evaluated for different regions of the brain both before a subject is exposed to stimulus and each time after the subject is exposed to stimulus.

[0027] Pre-stimulus and post-stimulus differential as well as target and distracter differential measurements of ERP time domain components at multiple regions of the brain are determined (DERP). Event related time-frequency analysis of the differential response to assess the attention, emotion and memory retention (DERPSPs) across multiple frequency bands including but not limited to theta, alpha, beta, gamma and high gamma is performed. In particular embodiments, single trial and/or averaged DERP and/or DERPSPs can be used to enhance the resonance measure

[0028] A resonance estimate may also incorporate relationship assessments using brain regional coherence measures of segments of the stimuli relevant to the entity/relationship, segment effectiveness measures synthesizing the attention, emotional engagement and memory retention estimates based on the neuro-physiological measures including time-frequency analysis of EEG measurements, and differential saccade related neural signatures during segments where coupling/relationship patterns are emerging in comparison to segments with non-coupled interactions.

[0029] According to various embodiments, a resonance estimator can include automated systems with or without human intervention for the elicitation of potential object/individual groupings. For example, these could also include pattern recognition and object identification techniques. These sub-systems could include a hardware implementation and/or software implementations.

[0030] A variety of stimulus materials such as entertainment and marketing materials, media streams, billboards, print advertisements, text streams, music, performances, sensory experiences, etc. can be analyzed. According to various embodiments, enhanced neuro-response data is generated using a data analyzer that performs both intra-modality measurement enhancements and cross-modality measurement enhancements. According to various embodiments, brain activity is measured not just to determine the regions of activity, but to determine interactions and types of interactions between various regions. The techniques and mechanisms of the present invention recognize that interactions between neural regions support orchestrated and organized behavior. Attention, emotion, memory, and other abilities are not merely based on one part of the brain but instead rely on network interactions between brain regions.

[0031] The techniques and mechanisms of the present invention further recognize that different frequency bands used for multi-regional communication can be indicative of the effectiveness of stimuli. In particular embodiments, evaluations are calibrated to each subject and synchronized across subjects. In particular embodiments, templates are created for subjects to create a baseline for measuring pre and post stimulus differentials. According to various embodiments, stimulus generators are intelligent and adaptively modify specific parameters such as exposure length and duration for each subject being analyzed.

[0032] A variety of modalities can be used including EEG, GSR, EKG, pupillary dilation, EOG, eye tracking, facial emotion encoding, reaction time, etc. Individual modalities such as EEG are enhanced by intelligently recognizing neural region communication pathways. Cross modality analysis is enhanced using a synthesis and analytical blending of central nervous system, autonomic nervous system, and effector sig-

natures. Synthesis and analysis by mechanisms such as time and phase shifting, correlating, and validating intra-modal determinations allow generation of a composite output characterizing the significance of various data responses to effectively perform resonance estimation.

[0033] FIG. 1 illustrates one example of a system for performing resonance estimation using central nervous system, autonomic nervous system, and/or effector measures. According to various embodiments, the resonance estimation system includes a stimulus presentation device **101**. In particular embodiments, the stimulus presentation device **101** is merely a display, monitor, screen, etc., that displays stimulus material to a user. The stimulus material may be a media clip, a commercial, pages of text, a brand image, a performance, a magazine advertisement, a movie, an audio presentation, and may even involve particular tastes, smells, textures and/or sounds. The stimuli can involve a variety of senses and occur with or without human supervision. Continuous and discrete modes are supported. According to various embodiments, the stimulus presentation device **101** also has protocol generation capability to allow intelligent customization of stimuli provided to multiple subjects in different markets.

[0034] According to various embodiments, stimulus presentation device **101** could include devices such as televisions, cable consoles, computers and monitors, projection systems, display devices, speakers, tactile surfaces, etc., for presenting the stimuli including but not limited to advertising and entertainment from different networks, local networks, cable channels, syndicated sources, websites, internet content aggregators, portals, service providers, etc.

[0035] According to various embodiments, the subjects are connected to data collection devices **105**. The data collection devices **105** may include a variety of neuro-response measurement mechanisms including neurological and neurophysiological measurements systems such as EEG, EOG, GSR, EKG, pupillary dilation, eye tracking, facial emotion encoding, and reaction time devices, etc. According to various embodiments, neuro-response data includes central nervous system, autonomic nervous system, and effector data. In particular embodiments, the data collection devices **105** include EEG **111**, EOG **113**, and GSR **115**. In some instances, only a single data collection device is used. Data collection may proceed with or without human supervision.

[0036] The data collection device **105** collects neuro-response data from multiple sources. This includes a combination of devices such as central nervous system sources (EEG), autonomic nervous system sources (GSR, EKG, pupillary dilation), and effector sources (EOG, eye tracking, facial emotion encoding, reaction time). In particular embodiments, data collected is digitally sampled and stored for later analysis. In particular embodiments, the data collected could be analyzed in real-time. According to particular embodiments, the digital sampling rates are adaptively chosen based on the neurophysiological and neurological data being measured.

[0037] In one particular embodiment, the resonance estimation system includes EEG **111** measurements made using scalp level electrodes, EOG **113** measurements made using shielded electrodes to track eye data, GSR **115** measurements performed using a differential measurement system, a facial muscular measurement through shielded electrodes placed at specific locations on the face, and a facial affect graphic and video analyzer adaptively derived for each individual.

[0038] In particular embodiments, the data collection devices are clock synchronized with a stimulus presentation

device **101**. In particular embodiments, the data collection devices **105** also include a condition evaluation subsystem that provides auto triggers, alerts and status monitoring and visualization components that continuously monitor the status of the subject, data being collected, and the data collection instruments. The condition evaluation subsystem may also present visual alerts and automatically trigger remedial actions. According to various embodiments, the data collection devices include mechanisms for not only monitoring subject neuro-response to stimulus materials, but also include mechanisms for identifying and monitoring the stimulus materials. For example, data collection devices **105** may be synchronized with a set-top box to monitor channel changes. In other examples, data collection devices **105** may be directionally synchronized to monitor when a subject is no longer paying attention to stimulus material. In still other examples, the data collection devices **105** may receive and store stimulus material generally being viewed by the subject, whether the stimulus is a program, a commercial, printed material, or a scene outside a window. The data collected allows analysis of neuro-response information and correlation of the information to actual stimulus material and not mere subject distractions.

[0039] According to various embodiments, the resonance estimation system also includes a data cleanser device **121**. In particular embodiments, the data cleanser device **121** filters the collected data to remove noise, artifacts, and other irrelevant data using fixed and adaptive filtering, weighted averaging, advanced component extraction (like PCA, ICA), vector and component separation methods, etc. This device cleanses the data by removing both exogenous noise (where the source is outside the physiology of the subject, e.g. a phone ringing while a subject is viewing a video) and endogenous artifacts (where the source could be neurophysiological, e.g. muscle movements, eye blinks, etc.).

[0040] The artifact removal subsystem includes mechanisms to selectively isolate and review the response data and identify epochs with time domain and/or frequency domain attributes that correspond to artifacts such as line frequency, eye blinks, and muscle movements. The artifact removal subsystem then cleanses the artifacts by either omitting these epochs, or by replacing these epoch data with an estimate based on the other clean data (for example, an EEG nearest neighbor weighted averaging approach).

[0041] According to various embodiments, the data cleanser device **121** is implemented using hardware, firmware, and/or software. It should be noted that although a data cleanser device **121** is shown located after a data collection device **105** and before data analyzer **181**, the data cleanser device **121** like other components may have a location and functionality that varies based on system implementation. For example, some systems may not use any automated data cleanser device whatsoever while in other systems, data cleanser devices may be integrated into individual data collection devices.

[0042] According to various embodiments, an optional stimulus attributes repository **131** provides information on the stimulus material being presented to the multiple subjects. According to various embodiments, stimulus attributes include properties of the stimulus materials as well as purposes, presentation attributes, report generation attributes, etc. In particular embodiments, stimulus attributes include time span, channel, rating, media, type, etc. Stimulus attributes may also include positions of entities in various

frames, object relationships, locations of objects and duration of display. Purpose attributes include aspiration and objects of the stimulus including excitement, memory retention, associations, etc. Presentation attributes include audio, video, imagery, and messages needed for enhancement or avoidance. Other attributes may or may not also be included in the stimulus attributes repository or some other repository.

[0043] The data cleanser device **121** and the stimulus attributes repository **131** pass data to the data analyzer **181**. The data analyzer **181** uses a variety of mechanisms to analyze underlying data in the system to determine resonance. According to various embodiments, the data analyzer customizes and extracts the independent neurological and neurophysiological parameters for each individual in each modality, and blends the estimates within a modality as well as across modalities to elicit an enhanced response to the presented stimulus material. In particular embodiments, the data analyzer **181** aggregates the response measures across subjects in a dataset.

[0044] According to various embodiments, neurological and neuro-physiological signatures are measured using time domain analyses and frequency domain analyses. Such analyses use parameters that are common across individuals as well as parameters that are unique to each individual. The analyses could also include statistical parameter extraction and fuzzy logic based attribute estimation from both the time and frequency components of the synthesized response.

[0045] In some examples, statistical parameters used in a blended effectiveness estimate include evaluations of skew, peaks, first and second moments, population distribution, as well as fuzzy estimates of attention, emotional engagement and memory retention responses.

[0046] According to various embodiments, the data analyzer **181** may include an intra-modality response synthesizer and a cross-modality response synthesizer. In particular embodiments, the intra-modality response synthesizer is configured to customize and extract the independent neurological and neurophysiological parameters for each individual in each modality and blend the estimates within a modality analytically to elicit an enhanced response to the presented stimuli. In particular embodiments, the intra-modality response synthesizer also aggregates data from different subjects in a dataset.

[0047] According to various embodiments, the cross-modality response synthesizer or fusion device blends different intra-modality responses, including raw signals and signals output. The combination of signals enhances the measures of effectiveness within a modality. The cross-modality response fusion device can also aggregate data from different subjects in a dataset.

[0048] According to various embodiments, the data analyzer **181** also includes a composite enhanced effectiveness estimator (CEEE) that combines the enhanced responses and estimates from each modality to provide a blended estimate of the effectiveness. In particular embodiments, blended estimates are provided for each exposure of a subject to stimulus materials. The blended estimates are evaluated over time to assess resonance characteristics. According to various embodiments, numerical values are assigned to each blended estimate. The numerical values may correspond to the intensity of neuro-response measurements, the significance of peaks, the change between peaks, etc. Higher numerical values may correspond to higher significance in neuro-response intensity. Lower numerical values may correspond to lower

significance or even insignificant neuro-response activity. In other examples, multiple values are assigned to each blended estimate. In still other examples, blended estimates of neuro-response significance are graphically represented to show changes after repeated exposure.

[0049] According to various embodiments, the data analyzer **181** provides analyzed and enhanced response data to a data communication device **183**. It should be noted that in particular instances, a data communication device **183** is not necessary. According to various embodiments, the data communication device **183** provides raw and/or analyzed data and insights. In particular embodiments, the data communication device **183** may include mechanisms for the compression and encryption of data for secure storage and communication.

[0050] According to various embodiments, the data communication device **183** transmits data using protocols such as the File Transfer Protocol (FTP), Hypertext Transfer Protocol (HTTP) along with a variety of conventional, bus, wired network, wireless network, satellite, and proprietary communication protocols. The data transmitted can include the data in its entirety, excerpts of data, converted data, and/or elicited response measures. According to various embodiments, the data communication device is a set top box, wireless device, computer system, etc. that transmits data obtained from a data collection device to a resonance estimator **185**. In particular embodiments, the data communication device may transmit data even before data cleansing or data analysis. In other examples, the data communication device may transmit data after data cleansing and analysis.

[0051] In particular embodiments, the data communication device **183** sends data to a resonance estimator **185**. According to various embodiments, the resonance estimator **185** assesses and extracts resonance patterns. In particular embodiments, the resonance estimator **185** determines entity positions in various stimulus segments and matches position information with eye tracking paths while correlating saccades with neural assessments of attention, memory retention, and emotional engagement. In particular embodiments, the resonance estimator **185** also collects and integrates user behavioral and survey responses with the analyzed response data to more effectively estimate resonance.

[0052] A variety of data can be stored for later analysis, management, manipulation, and retrieval. In particular embodiments, the repository could be used for tracking stimulus attributes and presentation attributes, audience responses and optionally could also be used to integrate audience measurement information.

[0053] As with a variety of the components in the system, the resonance estimator can be co-located with the rest of the system and the user, or could be implemented in a remote location. It could also be optionally separated into an assessment repository system that could be centralized or distributed at the provider or providers of the stimulus material. In other examples, the resonance estimator is housed at the facilities of a third party service provider accessible by stimulus material providers and/or users.

[0054] FIG. 2 illustrates examples of data models that may be provided with a stimulus attributes repository. According to various embodiments, a stimulus attributes data model **201** includes a channel **203**, media type **205**, time span **207**, audience **209**, and demographic information **211**. A stimulus purpose data model **215** may include intents **217** and objectives **219**. According to various embodiments, stimulus attributes

data model **201** also includes spatial and temporal information **221** about entities and emerging relationships between entities.

[0055] According to various embodiments, another stimulus attributes data model **221** includes creation attributes **223**, ownership attributes **225**, broadcast attributes **227**, and statistical, demographic and/or survey based identifiers for automatically integrating the neuro-physiological and neuro-behavioral response with other attributes and meta-information associated with the stimulus.

[0056] FIG. **3** illustrates examples of data models that can be used for storage of information associated with tracking and measurement of resonance. According to various embodiments, a dataset data model **301** includes an experiment name **303** and/or identifier, client attributes **305**, a subject pool **307**, logistics information **309** such as the location, date, and time of testing, and stimulus material **311** including stimulus material attributes.

[0057] In particular embodiments, a subject attribute data model **315** includes a subject name **317** and/or identifier, contact information **321**, and demographic attributes **319** that may be useful for review of neurological and neuro-physiological data. Some examples of pertinent demographic attributes include marriage status, employment status, occupation, household income, household size and composition, ethnicity, geographic location, sex, race. Other fields that may be included in data model **315** include shopping preferences, entertainment preferences, and financial preferences. Shopping preferences include favorite stores, shopping frequency, categories shopped, favorite brands. Entertainment preferences include network/cable/satellite access capabilities, favorite shows, favorite genres, and favorite actors. Financial preferences include favorite insurance companies, preferred investment practices, banking preferences, and favorite online financial instruments. A variety of subject attributes may be included in a subject attributes data model **315** and data models may be preset or custom generated to suit particular purposes.

[0058] According to various embodiments, data models for neuro-feedback association **325** identify experimental protocols **327**, modalities included **329** such as EEG, EOG, GSR, surveys conducted, and experiment design parameters **333** such as segments and segment attributes. Other fields may include experiment presentation scripts, segment length, segment details like stimulus material used, inter-subject variations, intra-subject variations, instructions, presentation order, survey questions used, etc. Other data models may include a data collection data model **337**. According to various embodiments, the data collection data model **337** includes recording attributes **339** such as station and location identifiers, the data and time of recording, and operator details. In particular embodiments, equipment attributes **341** include an amplifier identifier and a sensor identifier.

[0059] Modalities recorded **343** may include modality specific attributes like EEG cap layout, active channels, sampling frequency, and filters used. EOG specific attributes include the number and type of sensors used, location of sensors applied, etc. Eye tracking specific attributes include the type of tracker used, data recording frequency, data being recorded, recording format, etc. According to various embodiments, data storage attributes **345** include file storage conventions (format, naming convention, dating convention), storage location, archival attributes, expiry attributes, etc.

[0060] A preset query data model **349** includes a query name **351** and/or identifier, an accessed data collection **353** such as data segments involved (models, databases/cubes, tables, etc.), access security attributes **355** included who has what type of access, and refresh attributes **357** such as the expiry of the query, refresh frequency, etc. Other fields such as push-pull preferences can also be included to identify an auto push reporting driver or a user driven report retrieval system.

[0061] FIG. **4** illustrates examples of queries that can be performed to obtain data associated with resonance estimation. According to various embodiments, queries are defined from general or customized scripting languages and constructs, visual mechanisms, a library of preset queries, diagnostic querying including drill-down diagnostics, and eliciting what if scenarios. According to various embodiments, subject attributes queries **415** may be configured to obtain data from a neuro-informatics repository using a location **417** or geographic information, session information **421** such as testing times and dates, and demographic attributes **419**. Demographics attributes include household income, household size and status, education level, age of kids, etc.

[0062] Other queries may retrieve stimulus material based on shopping preferences of subject participants, countenance, physiological assessment, completion status. For example, a user may query for data associated with product categories, products shopped, shops frequented, subject eye correction status, color blindness, subject state, signal strength of measured responses, alpha frequency band ringers, muscle movement assessments, segments completed, etc. Experimental design based queries may obtain data from a neuro-informatics repository based on experiment protocols **427**, product category **429**, surveys included **431**, and stimulus provided **433**. Other fields that may be used include the number of protocol repetitions used, combination of protocols used, and usage configuration of surveys.

[0063] Client and industry based queries may obtain data based on the types of industries included in testing, specific categories tested, client companies involved, and brands being tested. Response assessment based queries **437** may include attention scores **439**, emotion scores, **441**, retention scores **443**, and effectiveness scores **445**. Such queries may obtain materials that elicited particular scores.

[0064] Response measure profile based queries may use mean measure thresholds, variance measures, number of peaks detected, etc. Group response queries may include group statistics like mean, variance, kurtosis, p-value, etc., group size, and outlier assessment measures. Still other queries may involve testing attributes like test location, time period, test repetition count, test station, and test operator fields. A variety of types and combinations of types of queries can be used to efficiently extract data.

[0065] FIG. **5** illustrates examples of reports that can be generated. According to various embodiments, client assessment summary reports **501** include effectiveness measures **503**, component assessment measures **505**, and resonance measures **507**. Effectiveness assessment measures include composite assessment measure(s), industry/category/client specific placement (percentile, ranking, etc.), actionable grouping assessment such as removing material, modifying segments, or fine tuning specific elements, etc. and the evolution of the effectiveness profile over time. In particular embodiments, component assessment reports include component assessment measures like attention, emotional

engagement scores, percentile placement, ranking, etc. Component profile measures include time based evolution of the component measures and profile statistical assessments. According to various embodiments, reports include the number of times material is assessed, attributes of the multiple presentations used, evolution of the response assessment measures over the multiple presentations, and usage recommendations.

[0066] According to various embodiments, client cumulative reports **511** include media grouped reporting **513** of all stimulus assessed, campaign grouped reporting **515** of stimulus assessed, and time/location grouped reporting **517** of stimulus assessed. According to various embodiments, industry cumulative and syndicated reports **521** include aggregate assessment responses measures **523**, top performer lists **525**, bottom performer lists **527**, outliers **529**, and trend reporting **531**. In particular embodiments, tracking and reporting includes specific products, categories, companies, brands.

[0067] FIG. 6 illustrates one example of resonance estimation. At **601**, stimulus material is provided to multiple subjects in multiple geographic markets. According to various embodiments, stimulus includes streaming video and audio provided over mechanisms such as broadcast television, cable television, satellite, etc. The stimulus may be presented to users in different geographic markets at the same or varying times. In particular embodiments, subjects view stimulus in their own homes in group or individual settings. At **603**, subject responses are collected using a variety of modalities, such as EEG, ERP, EOG, GSR, etc. In some examples, verbal and written responses can also be collected and correlated with neurological and neurophysiological responses. At **605**, data is passed through a data cleanser to remove noise and artifacts that may make data more difficult to interpret. According to various embodiments, the data cleanser removes EEG electrical activity associated with blinking and other endogenous/exogenous artifacts.

[0068] According to various embodiments, data analysis is performed. Data analysis may include intra-modality response synthesis and cross-modality response synthesis to enhance effectiveness measures. It should be noted that in some particular instances, one type of synthesis may be performed without performing other types of synthesis. For example, cross-modality response synthesis may be performed with or without intra-modality synthesis.

[0069] A variety of mechanisms can be used to perform data analysis. In particular embodiments, a stimulus attributes repository **131** is accessed to obtain attributes and characteristics of the stimulus materials, along with purposes, intents, objectives, etc. In particular embodiments, EEG response data is synthesized to provide an enhanced assessment of effectiveness. According to various embodiments, EEG measures electrical activity resulting from thousands of simultaneous neural processes associated with different portions of the brain. EEG data can be classified in various bands. According to various embodiments, brainwave frequencies include delta, theta, alpha, beta, and gamma frequency ranges. Delta waves are classified as those less than 4 Hz and are prominent during deep sleep. Theta waves have frequencies between 3.5 to 7.5 Hz and are associated with memories, attention, emotions, and sensations. Theta waves are typically prominent during states of internal focus.

[0070] Alpha frequencies reside between 7.5 and 13 Hz and typically peak around 10 Hz. Alpha waves are prominent during states of relaxation. Beta waves have a frequency

range between 14 and 30 Hz. Beta waves are prominent during states of motor control, long range synchronization between brain areas, analytical problem solving, judgment, and decision making. Gamma waves occur between 30 and 60 Hz and are involved in binding of different populations of neurons together into a network for the purpose of carrying out a certain cognitive or motor function, as well as in attention and memory. Because the skull and dermal layers attenuate waves in this frequency range, brain waves above 75-80 Hz are difficult to detect and are often not used for stimuli response assessment.

[0071] However, the techniques and mechanisms of the present invention recognize that analyzing high gamma band (kappa-band: Above 60 Hz) measurements, in addition to theta, alpha, beta, and low gamma band measurements, enhances neurological attention, emotional engagement and retention component estimates. In particular embodiments, EEG measurements including difficult to detect high gamma or kappa band measurements are obtained, enhanced, and evaluated. Subject and task specific signature sub-bands in the theta, alpha, beta, gamma and kappa bands are identified to provide enhanced response estimates. According to various embodiments, high gamma waves (kappa-band) above 80 Hz (typically detectable with sub-cranial EEG and/or magnetoencephalography) can be used in inverse model-based enhancement of the frequency responses to the stimuli.

[0072] Various embodiments of the present invention recognize that particular sub-bands within each frequency range have particular prominence during certain activities. A subset of the frequencies in a particular band is referred to herein as a sub-band. For example, a sub-band may include the 40-45 Hz range within the gamma band. In particular embodiments, multiple sub-bands within the different bands are selected while remaining frequencies are band pass filtered. In particular embodiments, multiple sub-band responses may be enhanced, while the remaining frequency responses may be attenuated.

[0073] An information theory based band-weighting model is used for adaptive extraction of selective dataset specific, subject specific, task specific bands to enhance the effectiveness measure. Adaptive extraction may be performed using fuzzy scaling. Stimuli can be presented and enhanced measurements determined multiple times to determine the variation profiles across multiple presentations. Determining various profiles provides an enhanced assessment of the primary responses as well as the longevity (wear-out) of the marketing and entertainment stimuli. The synchronous response of multiple individuals to stimuli presented in concert is measured to determine an enhanced across subject synchrony measure of effectiveness. According to various embodiments, the synchronous response may be determined for multiple subjects residing in separate locations or for multiple subjects residing in the same location.

[0074] Although a variety of synthesis mechanisms are described, it should be recognized that any number of mechanisms can be applied—in sequence or in parallel with or without interaction between the mechanisms.

[0075] Although intra-modality synthesis mechanisms provide enhanced significance data, additional cross-modality synthesis mechanisms can also be applied. A variety of mechanisms such as EEG, Eye Tracking, GSR, EOG, and facial emotion encoding are connected to a cross-modality synthesis mechanism. Other mechanisms as well as variations and enhancements on existing mechanisms may also be

included. According to various embodiments, data from a specific modality can be enhanced using data from one or more other modalities. In particular embodiments, EEG typically makes frequency measurements in different bands like alpha, beta and gamma to provide estimates of significance. However, the techniques of the present invention recognize that significance measures can be enhanced further using information from other modalities.

[0076] For example, facial emotion encoding measures can be used to enhance the valence of the EEG emotional engagement measure. EOG and eye tracking saccadic measures of object entities can be used to enhance the EEG estimates of significance including but not limited to attention, emotional engagement, and memory retention. According to various embodiments, a cross-modality synthesis mechanism performs time and phase shifting of data to allow data from different modalities to align. In some examples, it is recognized that an EEG response will often occur hundreds of milliseconds before a facial emotion measurement changes. Correlations can be drawn and time and phase shifts made on an individual as well as a group basis. In other examples, saccadic eye movements may be determined as occurring before and after particular EEG responses. According to various embodiments, time corrected GSR measures are used to scale and enhance the EEG estimates of significance including attention, emotional engagement and memory retention measures.

[0077] Evidence of the occurrence or non-occurrence of specific time domain difference event-related potential components (like the DERP) in specific regions correlates with subject responsiveness to specific stimulus. According to various embodiments, ERP measures are enhanced using EEG time-frequency measures (ERPSP) in response to the presentation of the marketing and entertainment stimuli. Specific portions are extracted and isolated to identify ERP, DERP and ERPSP analyses to perform. In particular embodiments, an EEG frequency estimation of attention, emotion and memory retention (ERPSP) is used as a co-factor in enhancing the ERP, DERP and time-domain response analysis.

[0078] EOG measures saccades to determine the presence of attention to specific objects of stimulus. Eye tracking measures the subject's gaze path, location and dwell on specific objects of stimulus. According to various embodiments, EOG and eye tracking is enhanced by measuring the presence of lambda waves (a neurophysiological index of saccade effectiveness) in the ongoing EEG in the occipital and extra striate regions, triggered by the slope of saccade-onset to estimate the significance of the EOG and eye tracking measures. In particular embodiments, specific EEG signatures of activity such as slow potential shifts and measures of coherence in time-frequency responses at the Frontal Eye Field (FEF) regions that preceded saccade-onset are measured to enhance the effectiveness of the saccadic activity data.

[0079] GSR typically measures the change in general arousal in response to stimulus presented. According to various embodiments, GSR is enhanced by correlating EEG/ERP responses and the GSR measurement to get an enhanced estimate of subject engagement. The GSR latency baselines are used in constructing a time-corrected GSR response to the stimulus. The time-corrected GSR response is co-factored with the EEG measures to enhance GSR significance measures.

[0080] According to various embodiments, facial emotion encoding uses templates generated by measuring facial muscle positions and movements of individuals expressing various emotions prior to the testing session. These individual specific facial emotion encoding templates are matched with the individual responses to identify subject emotional response. In particular embodiments, these facial emotion encoding measurements are enhanced by evaluating inter-hemispherical asymmetries in EEG responses in specific frequency bands and measuring frequency band interactions. The techniques of the present invention recognize that not only are particular frequency bands significant in EEG responses, but particular frequency bands used for communication between particular areas of the brain are significant. Consequently, these EEG responses enhance the EMG, graphic and video based facial emotion identification.

[0081] According to various embodiments, post-stimulus versus pre-stimulus differential measurements of ERP time domain components in multiple regions of the brain (DERP) are measured at **607**. The differential measures give a mechanism for eliciting responses attributable to the stimulus. For example the messaging response attributable to an ad or the brand response attributable to multiple brands is determined using pre-resonance and post-resonance estimates

[0082] At **609**, target versus distracter stimulus differential responses are determined for different regions of the brain (DERP). At **611**, event related time-frequency analysis of the differential response (DERPSPs) are used to assess the attention, emotion and memory retention measures across multiple frequency bands. According to various embodiments, the multiple frequency bands include theta, alpha, beta, gamma and high gamma or kappa. At **613**, multiple trials are performed to enhance resonance measures.

[0083] At **615**, processed data is provided to a data communication device for transmission over a network such as a wireless, wireline, satellite, or other type of communication network capable of transmitting data. Data is provided to resonance estimator at **617**. According to various embodiments, the data communication device transmits data using protocols such as the File Transfer Protocol (FTP), Hypertext Transfer Protocol (HTTP) along with a variety of conventional, bus, wired network, wireless network, satellite, and proprietary communication protocols. The data transmitted can include the data in its entirety, excerpts of data, converted data, and/or elicited response measures. According to various embodiments, data is sent using a telecommunications, wireless, Internet, satellite, or any other communication mechanisms that is capable of conveying information from multiple subject locations for data integration and analysis. The mechanism may be integrated in a set top box, computer system, receiver, mobile device, etc.

[0084] In particular embodiments, the data communication device sends data to the resonance estimator. According to various embodiments, the resonance estimator combines analyzed and enhanced responses to the stimulus material while using information about stimulus material attributes such as the location, movement, acceleration, and spatial relationships of various entities and objects. In particular embodiments, the resonance estimator also collects and integrates user behavioral and survey responses with the analyzed and enhanced response data to more effectively assessment resonance patterns.

[0085] FIG. 7 illustrates an example of a technique for estimating resonance. According to various embodiments,

measurements from different modalities are obtained at **701**. According to various embodiments, measurements including Differential Event Related Potential (DERP), Differential Event Related Power Spectral Perturbations (DERPSPs), Pupillary Response, etc., are blended to obtain a combined measurement at **703**. In particular embodiments, each measurement may have to be aligned appropriately in order to allow blending. According to various embodiments, a resonance estimator includes mechanisms to use and blend different measures from across the modalities from the data analyzer. In particular embodiments, the data includes the DERP measures, DERPSPs, pupillary response, GSR, eye movement, coherence, coupling and lambda wave based response. Measurements across modalities are blended to elicit a synthesized measure of user resonance.

[0086] At **705**, neuro-response measurements such as DERP, DERPSPs, pupillary response, etc., are combined with statistical, demographic, and/or survey based information. The device contains mechanisms to integrate the neuro-physiological and neuro-behavioral response with other attributes and meta information on the stimulus (statistical, demographic and/or survey based) for the selection of targets for additional stimulus preparation/presentation at **713**.

[0087] The resonance estimator can further include an adaptive learning component that refines profiles and tracks variations responses to particular stimuli or series of stimuli over time. This information can be made available for other purposes, such as use of the information for presentation attribute decision making. According to various embodiments, the resonance estimator generates an index for use of evaluation. Data and measurements are stored in a repository for later retrieval and analysis.

[0088] According to various embodiments, various mechanisms such as the data collection mechanisms, the intra-modality synthesis mechanisms, cross-modality synthesis mechanisms, etc. are implemented on multiple devices. However, it is also possible that the various mechanisms be implemented in hardware, firmware, and/or software in a single system. FIG. **8** provides one example of a system that can be used to implement one or more mechanisms. For example, the system shown in FIG. **8** may be used to implement a resonance measurement system.

[0089] According to particular example embodiments, a system **800** suitable for implementing particular embodiments of the present invention includes a processor **801**, a memory **803**, an interface **811**, and a bus **815** (e.g., a PCI bus). When acting under the control of appropriate software or firmware, the processor **801** is responsible for such tasks such as pattern generation. Various specially configured devices can also be used in place of a processor **801** or in addition to processor **801**. The complete implementation can also be done in custom hardware. The interface **811** is typically configured to send and receive data packets or data segments over a network. Particular examples of interfaces the device supports include host bus adapter (HBA) interfaces, Ethernet interfaces, frame relay interfaces, cable interfaces, DSL interfaces, token ring interfaces, and the like.

[0090] In addition, various very high-speed interfaces may be provided such as fast Ethernet interfaces, Gigabit Ethernet interfaces, ATM interfaces, HSSI interfaces, POS interfaces, FDDI interfaces and the like. Generally, these interfaces may include ports appropriate for communication with the appropriate media. In some cases, they may also include an independent processor and, in some instances, volatile RAM. The

independent processors may control such communications intensive tasks as data synthesis.

[0091] According to particular example embodiments, the system **800** uses memory **803** to store data, algorithms and program instructions. The program instructions may control the operation of an operating system and/or one or more applications, for example. The memory or memories may also be configured to store received data and process received data.

[0092] Because such information and program instructions may be employed to implement the systems/methods described herein, the present invention relates to tangible, machine readable media that include program instructions, state information, etc. for performing various operations described herein. Examples of machine-readable media include, but are not limited to, magnetic media such as hard disks, floppy disks, and magnetic tape; optical media such as CD-ROM disks and DVDs; magneto-optical media such as optical disks; and hardware devices that are specially configured to store and perform program instructions, such as read-only memory devices (ROM) and random access memory (RAM). Examples of program instructions include both machine code, such as produced by a compiler, and files containing higher level code that may be executed by the computer using an interpreter.

[0093] Although the foregoing invention has been described in some detail for purposes of clarity of understanding, it will be apparent that certain changes and modifications may be practiced within the scope of the appended claims. Therefore, the present embodiments are to be considered as illustrative and not restrictive and the invention is not to be limited to the details given herein, but may be modified within the scope and equivalents of the appended claims.

What is claimed is:

1. A system, comprising:
 - a stimulus presentation device operable to provide stimulus material to a subject;
 - a data collection device operable to obtain neuro-response data including pre-stimulus and post-stimulus event related potential (ERP) measurements to determine differential measurements of ERP time domain components at multiple regions of the brain (DERP);
 - a resonance estimator operable to determine a subject resonance measurement to the stimulus material and attributes of the stimulus material.
2. The system of claim **1**, wherein the data collection device is further operable to obtain target and distracter ERP measurements to determine differential measurements of ERP time domain components at multiple regions of the brain (DERP).
3. The system of claim **1**, wherein the data collection device is further operable to obtain event related time-frequency analysis of the differential response to assess the attention, emotion and memory retention (DERPSPs) across multiple frequency bands.
4. The system of claim **3**, wherein the multiple frequency bands comprise theta, alpha, beta, gamma and high gamma.
5. The system of claim **1**, wherein attributes of the stimulus material comprise communication, concept, experience, message, images, audio, pricing, packaging.
6. The system of claim **1**, wherein the subject resonance measurement to identify selective targets for additional marketing, advertising and other audio/visual/tactile/olfactory stimulus.

7. The system of claim 1, further comprising a data analyzer operable to determine the DERP.

8. The system of claim 1, wherein the data collection device is further operable to obtain pupillary dilation, galvanic skin response (GSR), and heart rate measurements for the subject.

9. The system of claim 1, wherein neuro-response data includes central nervous system and autonomic nervous system data.

10. The system of claim 1, wherein neuro-response data includes central nervous system and effector data.

11. The system of claim 1, wherein combinations of neurological and neurophysiological measurements including attention, emotion, and memory retention are used to perform resonance estimation.

12. The system of claim 1, wherein neuro-response data is obtained from the plurality of subjects using portable Electroencephalography (EEG) with dry electrodes.

13. The system of claim 11, wherein neuro-response data from a first modality is aligned and combined with neuro-response data from a second modality.

14. The system of claim 12, wherein aligning neuro-response data from a first modality with neuro-response data from a second modality comprises time and phase shifting.

15. A method, comprising:

providing stimulus material to a subject;
obtaining neuro-response data including pre-stimulus and post-stimulus event related potential (ERP) measurements to determine differential measurements of ERP time domain components at multiple regions of the brain (DERP);

determining a subject resonance measurement to the stimulus material and attributes of the stimulus material.

16. The method of claim 15, further comprising obtaining target and distracter ERP measurements to determine differential measurements of ERP time domain components at multiple regions of the brain (DERP).

17. The method of claim 15, further comprising obtaining event related time-frequency analysis of the differential response to assess the attention, emotion and memory retention (DERPSPs) across multiple frequency bands.

18. An apparatus, comprising:

means for providing stimulus material to a subject;
means for obtaining neuro-response data including pre-stimulus and post-stimulus event related potential (ERP) measurements to determine differential measurements of ERP time domain components at multiple regions of the brain (DERP);
means for determining a subject resonance measurement to the stimulus material and attributes of the stimulus material.

19. The apparatus of claim 18, further comprising means for obtaining target and distracter ERP measurements to determine differential measurements of ERP time domain components at multiple regions of the brain (DERP).

20. The apparatus of claim 18, further comprising means for obtaining event related time-frequency analysis of the differential response to assess the attention, emotion and memory retention (DERPSPs) across multiple frequency bands.

* * * * *

专利名称(译)	神经反应刺激和刺激属性共振估计		
公开(公告)号	US20090036756A1	公开(公告)日	2009-02-05
申请号	US12/182874	申请日	2008-07-30
申请(专利权)人(译)	NeuroFocus的, INC.		
当前申请(专利权)人(译)	NeuroFocus的, INC.		
[标]发明人	PRADEEP ANANTHA KNIGHT ROBERT T GURUMOORTHY RAMACHANDRAN		
发明人	PRADEEP, ANANTHA KNIGHT, ROBERT T. GURUMOORTHY, RAMACHANDRAN		
IPC分类号	A61B5/0484 A61B5/00		
CPC分类号	A61B5/0402 A61B5/0484 A61B5/0496 A61B5/0533 G06Q30/0242 A61B5/7207 A61B5/7278 G06Q30/02 G06Q30/00 A61B5/16 A61B5/163 A61B5/4035		
优先权	60/952723 2007-07-30 US		
其他公开文献	US8533042		
外部链接	Espacenet USPTO		

摘要(译)

系统确定神经反应刺激和刺激属性共振。使用通过事件相关电位 (ERP), 脑电图 (EEG), 电流皮肤等机制收集的神经反应数据评估刺激材料和刺激材料属性, 如沟通, 概念, 经验, 信息, 图像, 音频, 定价和包装。响应 (GSR), 心电图 (EKG), 电眼 (EOG), 眼动追踪和面部情感编码。分析神经反应数据以确定刺激和刺激属性共振。

