



US 20070078315A1

(19) **United States**

(12) **Patent Application Publication**

Kling et al.

(10) **Pub. No.: US 2007/0078315 A1**

(43) **Pub. Date: Apr. 5, 2007**

(54) **CLIP-STYLE MEDICAL SENSOR AND TECHNIQUE FOR USING THE SAME**

(22) Filed: **Sep. 30, 2005**

Publication Classification

(76) Inventors: **Carl Kling**, San Ramon, CA (US);
Phillip S. Palmer, San Leandro, CA (US); **Robert W. Flagler**, Pleasanton, CA (US)

(51) **Int. Cl.**
A61B 5/00 (2006.01)

(52) **U.S. Cl.** **600/323**

(57) **ABSTRACT**

A clip-style sensor is provided that includes a sliding clip, such as a flat spring that slides along the sensor to provide a closing force for the sensor. When the sliding clip is engaged, the sensor is secured to the patient. The sensor may be placed on a patient's finger, toe, ear, and so forth to obtain pulse oximetry or other spectrophotometric measurements.

Correspondence Address:
FLETCHER YODER (TYCO INTERNATIONAL, LTD.)
P.O. BOX 692289
HOUSTON, TX 77269-2289 (US)

(21) Appl. No.: **11/239,809**

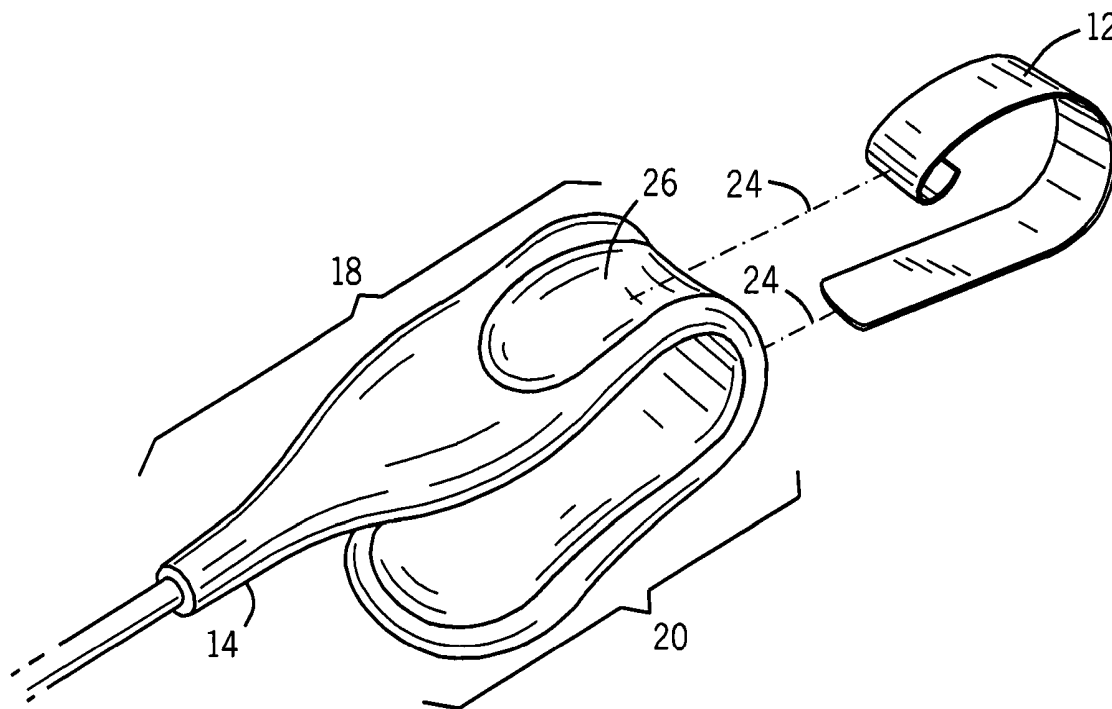

FIG. 1A

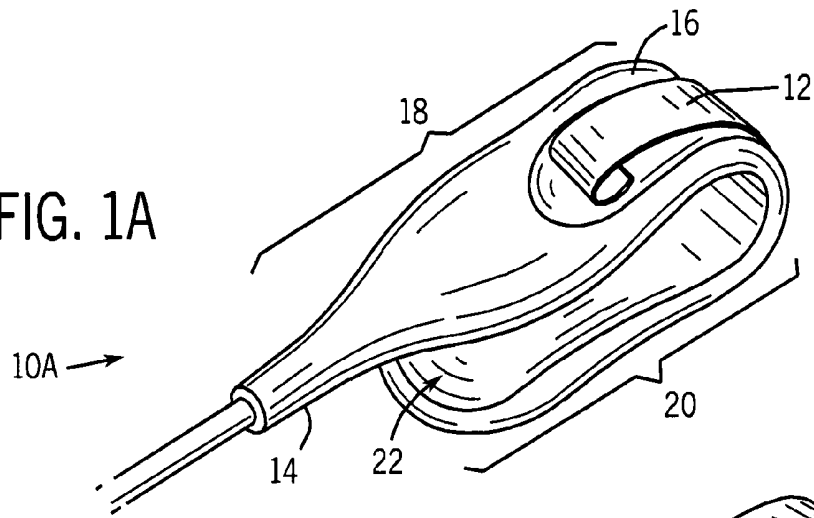

FIG. 1B

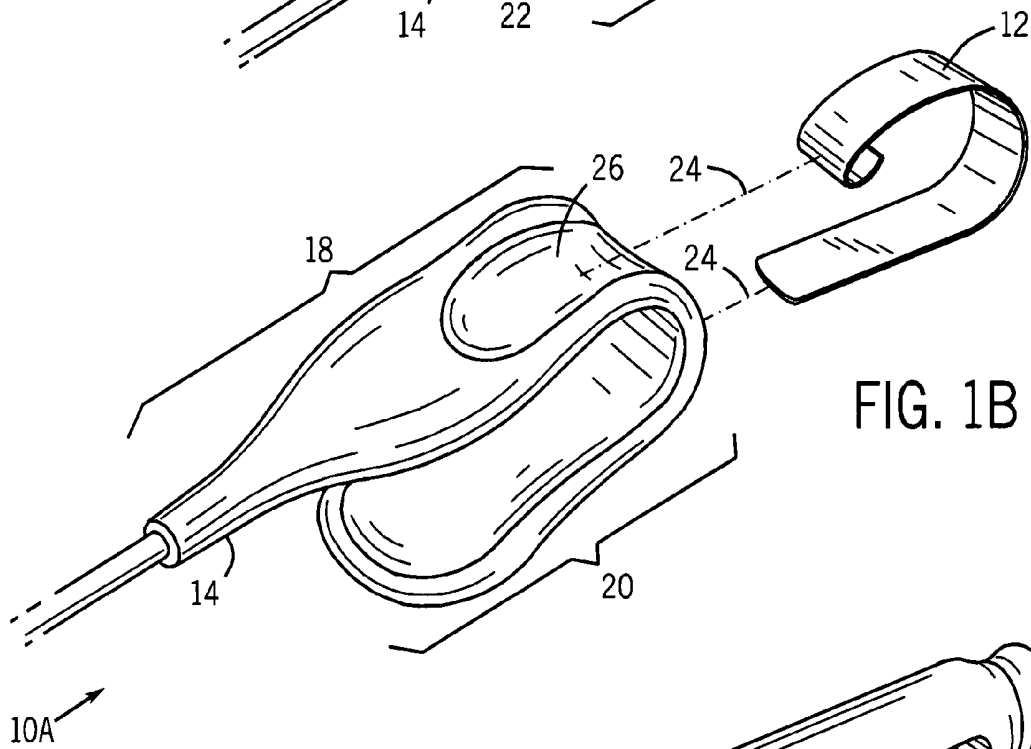
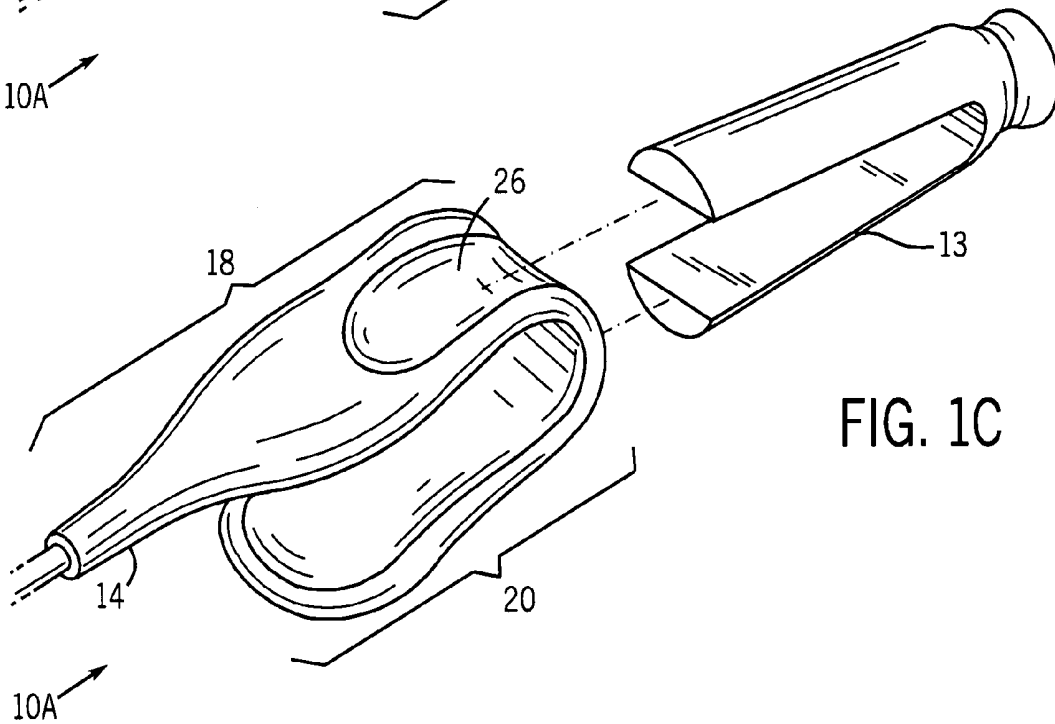
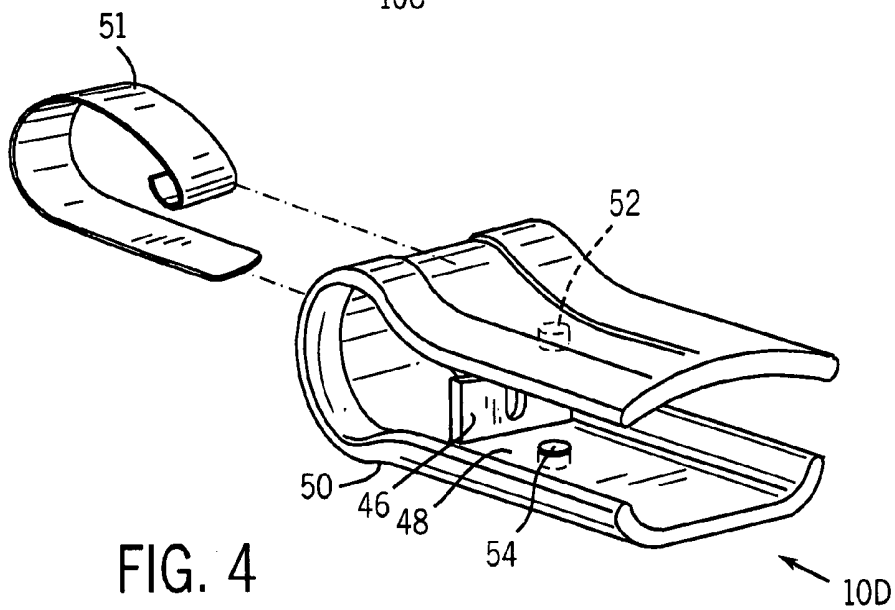
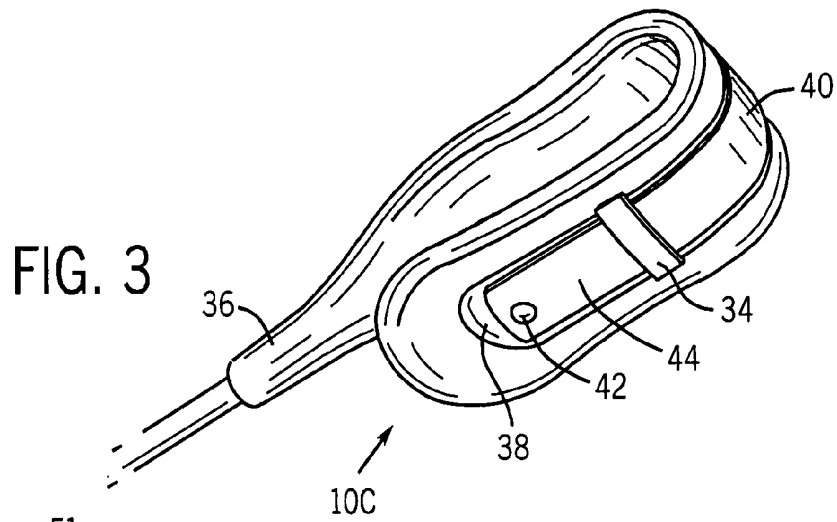
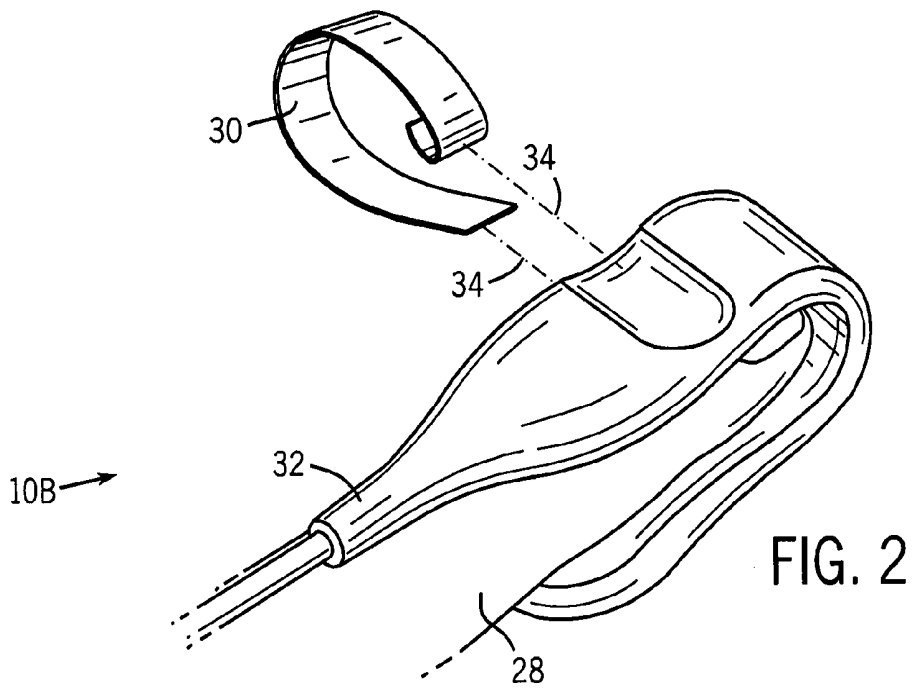
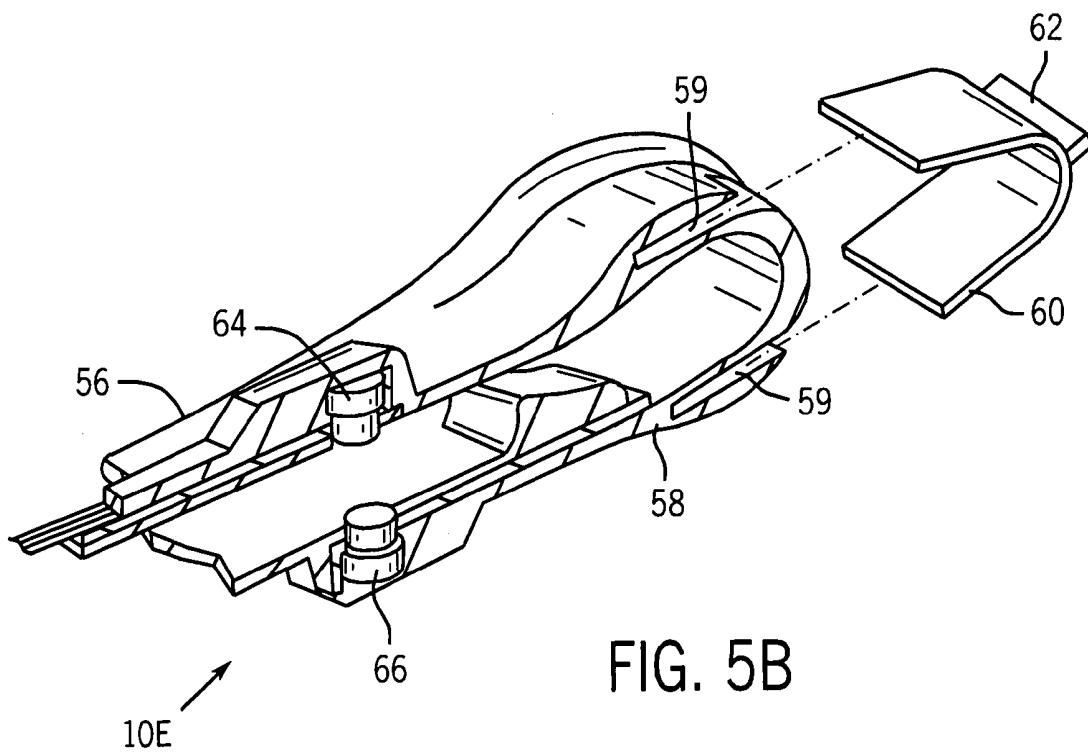
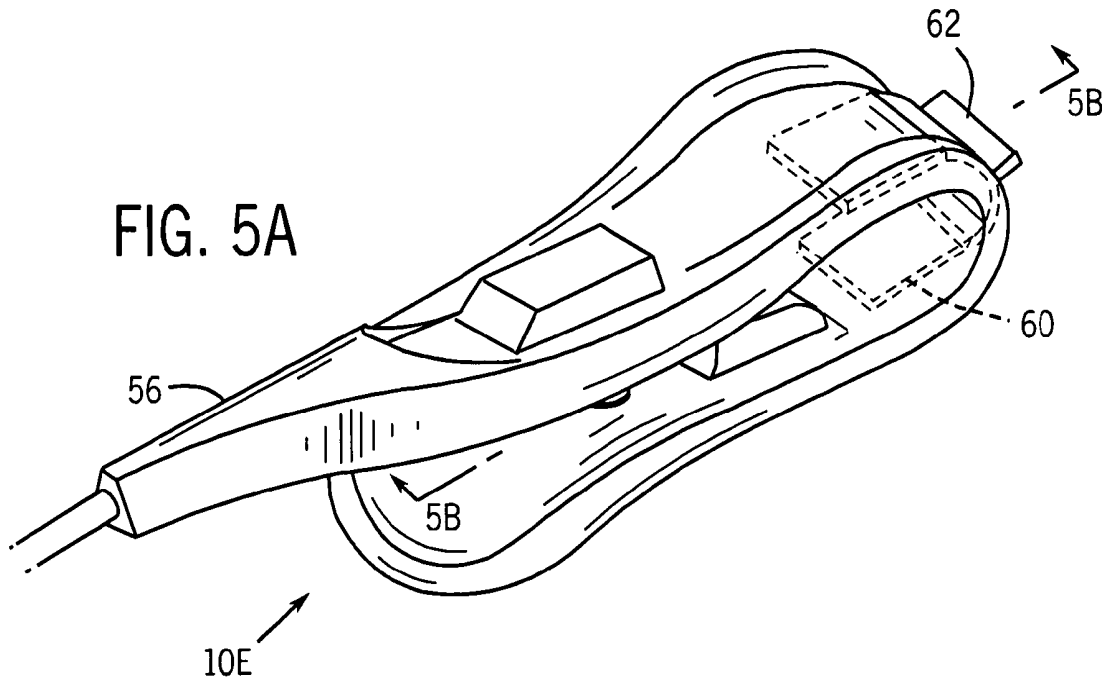

FIG. 1C







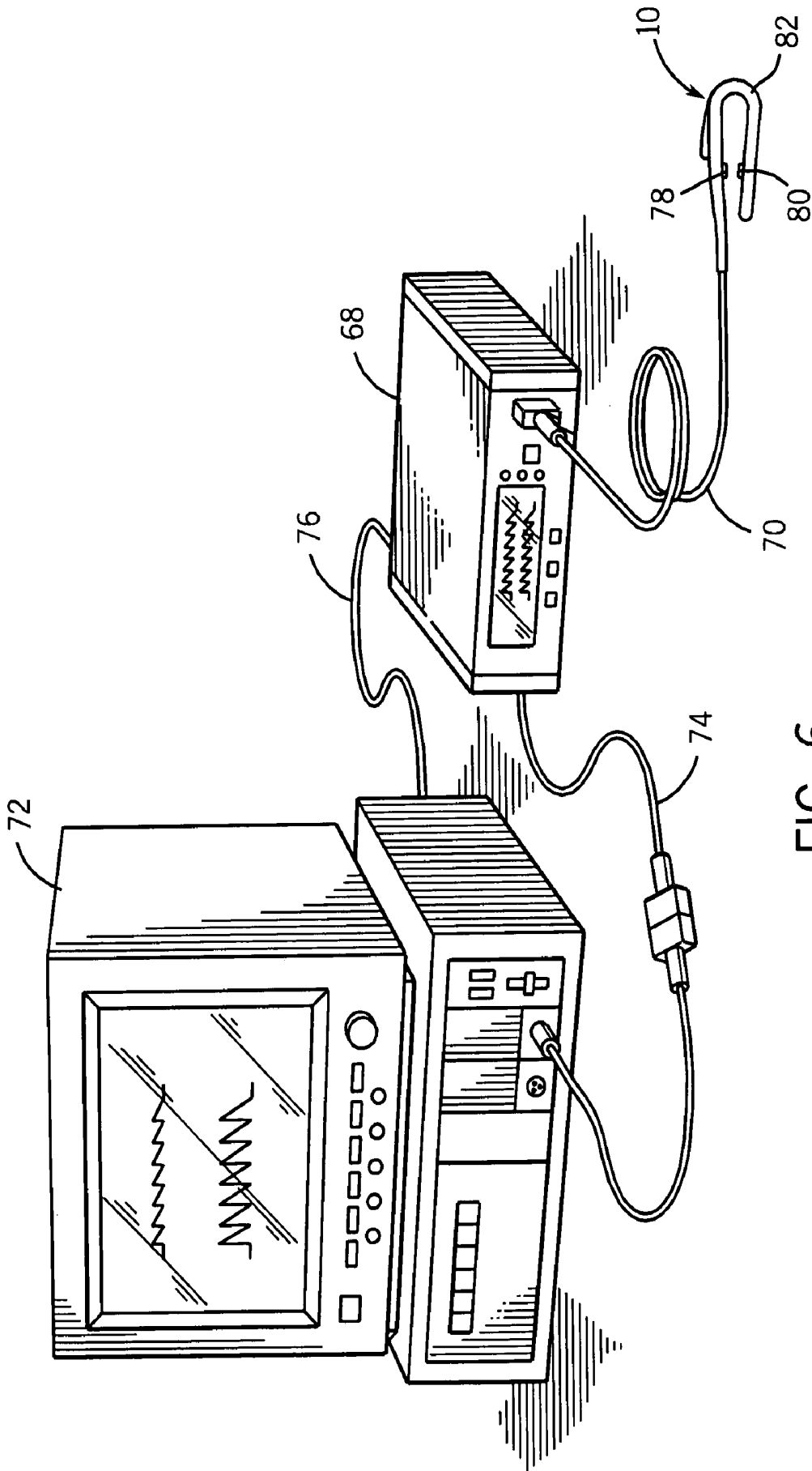

FIG. 6

CLIP-STYLE MEDICAL SENSOR AND TECHNIQUE FOR USING THE SAME

BACKGROUND OF THE INVENTION

[0001] 1. Field of the Invention

[0002] The present invention relates generally to medical devices and, more particularly, to sensors used for sensing physiological parameters of a patient.

[0003] 2. Description of the Related Art

[0004] This section is intended to introduce the reader to various aspects of art that may be related to various aspects of the present invention, which are described and/or claimed below. This discussion is believed to be helpful in providing the reader with background information to facilitate a better understanding of the various aspects of the present invention. Accordingly, it should be understood that these statements are to be read in this light, and not as admissions of prior art.

[0005] In the field of medicine, doctors often desire to monitor certain physiological characteristics of their patients. Accordingly, a wide variety of devices have been developed for monitoring many such characteristics. Such devices provide doctors and other healthcare personnel with the information they need to provide the best possible healthcare for their patients. As a result, such monitoring devices have become an indispensable part of modern medicine.

[0006] One technique for monitoring certain physiological characteristics of a patient is commonly referred to as pulse oximetry, and the devices built based upon pulse oximetry techniques are commonly referred to as pulse oximeters. Pulse oximetry may be used to measure various blood flow characteristics, such as the blood-oxygen saturation of hemoglobin in arterial blood, the volume of individual blood pulsations supplying the tissue, and/or the rate of blood pulsations corresponding to each heartbeat of a patient.

[0007] Pulse oximeters typically utilize a non-invasive sensor that is placed on or against a patient's tissue that is well perfused with blood, such as a patient's finger, toe, forehead or earlobe. The pulse oximeter sensor emits light and photoelectrically senses the absorption and/or scattering of the light after passage through the perfused tissue. The data collected by the sensor may then be used to calculate one or more of the above physiological characteristics based upon the absorption or scattering of the light. More specifically, the emitted light is typically selected to be of one or more wavelengths that are absorbed or scattered in an amount related to the presence of oxygenated versus deoxygenated hemoglobin in the blood. The amount of light absorbed and/or scattered may then be used to estimate the amount of the oxygen in the tissue using various algorithms.

[0008] In many instances, it may be desirable to employ, for cost and/or convenience, a pulse oximeter sensor that is reusable. Such reusable sensors, however, may be uncomfortable for the patient for various reasons. For example, the materials used in their construction may not be adequately compliant or supple or the structural features may include angles or edges.

[0009] Furthermore, the reusable sensor should fit snugly enough that incidental patient motion will not dislodge or

move the sensor, yet not so tight that it may interfere with pulse oximetry measurements. Such a conforming fit may be difficult to achieve over a range of patient physiologies without adjustment or excessive attention on the part of medical personnel. In addition, lack of a tight or secure fit may allow light from the environment to reach the photo-detecting elements of the sensor. Such environmental light is not related to a physiological characteristic of the patient and may, therefore, introduce error into the measurements derived using data obtained with the sensor.

[0010] Reusable pulse oximeter sensors are also used repeatedly and, typically, on more than one patient. Therefore, over the life of the sensor, detritus and other bio-debris (sloughed off skin cells, dried fluids, dirt, and so forth) may accumulate on the surface of the sensor or in crevices and cavities of the sensor, after repeated uses. As a result, it may be desirable to quickly and/or routinely clean the sensor in a thorough manner. However, in sensors having a multi-part construction, as is typical in reusable pulse oximeter sensors, it may be difficult to perform such a quick and/or routine cleaning. For example, such a thorough cleaning may require disassembly of the sensor and individual cleaning of the disassembled parts or may require careful cleaning using utensils capable of reaching into cavities or crevices of the sensor. Such cleaning is labor intensive and may be impractical in a typical hospital or clinic environment.

SUMMARY

[0011] Certain aspects commensurate in scope with the originally claimed invention are set forth below. It should be understood that these aspects are presented merely to provide the reader with a brief summary of certain forms that the invention might take and that these aspects are not intended to limit the scope of the invention. Indeed, the invention may encompass a variety of aspects that may not be set forth below.

[0012] There is provided a sensor that includes: a sensor body comprising a first portion and a second portion; at least one sensing element disposed on the sensor body; and a sliding clip adapted to slide along the sensor body to bias the first portion towards the second portion.

[0013] There is also provided a sensor that includes: a sensor body comprising a first portion and a second portion; at least one sensing element disposed on the sensor body; and a sliding mechanism adapted to move between an engaged position and a disengaged position, wherein the first portion and the second portion are biased towards one another when the sliding mechanism is in the engaged position.

[0014] There is also provided a pulse oximetry system that includes: a pulse oximetry monitor; and a pulse oximetry sensor adapted to be operatively coupled to the monitor, the sensor including: a sensor body comprising a first portion and a second portion; at least one sensing element disposed on the sensor body; and a sliding clip adapted to slide along the sensor body to bias the first portion towards the second portion.

[0015] There is also provided a method of manufacturing a sensor, the method including:

[0016] providing a sensor body comprising a first portion and a second portion and at least one sensing element; and

providing a sliding clip adapted to slide along the sensor body to bias the first portion towards the second portion.

[0017] There is also provided a method of applying a sensor, the method including:

[0018] inserting a patient's tissue into a sensor body having at least one sensing element; and

[0019] sliding a clip into an engaged position. There is also provided a sensor kit, the kit comprising: a first sensor body having a first size, the first sensor body comprising: a first portion and a second portion; at least one sensing element disposed on the first sensor body; a second sensor body having a second size, the second sensor body comprising: a first portion and a second portion; at least one sensing element disposed on the second sensor body; and at least one detachable clip, wherein the detachable clip is adapted to slide along the first sensor body or the second sensor body.

[0020] There is also provided a sensor kit, the kit comprising: A pulse oximetry sensor kit, comprising: at least one sensor body comprising: a first portion and a second portion; at least one sensing element disposed on the sensor body; a first detachable clip having a first size, wherein the detachable clip is adapted to bias the first portion towards the second portion; and a second detachable clip having a second size, wherein the second detachable clip is adapted to bias the first portion towards the second portion.

[0021] There is also provided a sensor that includes a sensor body comprising a first portion and a second portion; at least one sensing element disposed on the sensor body; and a detachable clip adapted to bias the first portion towards the second portion.

[0022] There is also provided a pulse oximetry system that includes: a pulse oximeter monitor; and a pulse oximetry sensor configured to communicate with the pulse oximetry monitor, the pulse oximetry sensor comprising: a sensor body comprising a first portion and a second portion; at least one sensing element disposed on the sensor body; and a detachable clip adapted to bias the first portion towards the second portion.

[0023] There is also provided a method of manufacturing a sensor that includes: providing a sensor body comprising a first portion and a second portion and having at least one sensing element disposed thereon; and providing a detachable clip adapted to bias the first portion towards the second portion.

[0024] There is also provided a method that includes: inserting a patient's tissue into a sensor body having a first portion and a second portion and at least one sensing element; and applying a detachable clip to the sensor body to bias the first portion towards the second portion.

BRIEF DESCRIPTION OF THE DRAWINGS

[0025] Advantages of the invention may become apparent upon reading the following detailed description and upon reference to the drawings in which:

[0026] FIG. 1A illustrates a perspective view of an exemplary sensor with an engaged sliding flat spring for use in a pulse oximetry sensor, in accordance with aspects of the present technique;

[0027] FIG. 1B illustrates a perspective view of the sensor of FIG. 1A in which the sliding flat spring is in the disengaged position;

[0028] FIG. 1C illustrates a perspective view of the sensor of FIG. 1A in which a clothespin-like clip is in the disengaged position;

[0029] FIG. 2 illustrates a perspective view of an exemplary sensor with a sliding flat spring that slides orthogonally to the site of tissue insertion, in accordance with aspects of the present technique;

[0030] FIG. 3 illustrates a perspective view of an exemplary sensor with a sliding flat spring and a retaining clip and guard, in accordance with aspects of the present technique;

[0031] FIG. 4 illustrates a perspective view of an exemplary sensor with a sliding flat spring and a finger stop;

[0032] FIG. 5A illustrates a perspective view of an exemplary overmolded sensor with an internal frame and an embedded spring, in accordance with aspects of the present technique;

[0033] FIG. 5B illustrates a cross-section of the overmolded sensor depicted in FIG. 5A; and

[0034] FIG. 6 illustrates a pulse oximetry system coupled to a multi-parameter patient monitor and a pulse oximetry sensor, in accordance with aspects of the present technique;

DETAILED DESCRIPTION OF SPECIFIC EMBODIMENTS

[0035] One or more specific embodiments of the present invention will be described below. In an effort to provide a concise description of these embodiments, not all features of an actual implementation are described in the specification. It should be appreciated that in the development of any such actual implementation, as in any engineering or design project, numerous implementation-specific decisions must be made to achieve the developers' specific goals, such as compliance with system-related and business-related constraints, which may vary from one implementation to another. Moreover, it should be appreciated that such a development effort might be complex and time consuming, but would nevertheless be a routine undertaking of design, fabrication, and manufacture for those of ordinary skill having the benefit of this disclosure.

[0036] It is desirable to provide a reusable sensor for pulse oximetry or other applications utilizing spectrophotometry that is easily cleaned, comfortable, and easy to apply to a patient. In accordance with the present technique, a reusable clip-style sensor is provided that includes a sliding or removable mechanism, such as a metal flat spring or a torsion spring, providing a closing bias to allow the sensor to be placed securely on a patient. In accordance with some aspects of the present techniques, the reusable clip-style sensor is configured to provide patient comfort and a suitably conformable fit over a wide variety of patient sizes.

[0037] Pulse oximetry sensors are typically placed on a patient in a location that is normally perfused with arterial blood to facilitate measurement of the desired blood characteristics, such as arterial oxygen saturation measurement (SpO_2). Common sensor sites include a patient's fingertips, toes, or earlobes. Regardless of the placement of a pulse

oximetry sensor 10, the reliability of the pulse oximetry measurement is related to the accurate detection of transmitted light that has passed through the perfused tissue. Hence, a sensor 10 that fits a patient securely may reduce movement of the sensor or infiltration of light from outside sources into the sensor, and thus may provide more accurate pulse oximetry measurements.

[0038] Referring now to FIG. 1A and FIG. 1B, an exemplary sensor 10A is depicted having an external flat spring 12. FIG. 1A illustrates a perspective view of a sensor 10A with an external flat spring 12 in the closed, or engaged, position. The flat spring 12 is fitted at or near the end of the sensor body 14 that is opposite from where the finger, toe, or other patient appendage is inserted into the assembled sensor. The flat spring 12 may be slidably disposed on a surface 16 of the sensor body 14 that does not contact the tissue during normal use. In the depicted embodiment, the flat spring 12 (or other biasing mechanism) provides or contributes to a closing force applied to a first portion 18 and a second portion 20 of the sensor body such that the first portion 18 and second portion 20 are pushed together when the flat spring 12 is engaged. Thus, after a tissue is inserted into the sensor 10A, the flat spring 12 may slide toward the site 22 of tissue insertion to move the sensor 10A to the closed position. Generally, the sensor 10A is in the closed position when the flat spring 12 is fully flush against the surface 16 of the sensor body 14 that does not contact the tissue during normal use.

[0039] FIG. 1B shows the sensor 10A with the flat spring 12 in the open, or disengaged, position. The flat spring 12 may slide along the sensor body 14 along an imaginary axis 24 in order to move the sensor 10A from the closed position to the open position. As depicted, the sensor body 14 has a depression 26 disposed on the surface 16 of the sensor body that does not contact the tissue during normal use. The depression 26 may be suitably sized and shaped to accommodate the flat spring 12, and to allow the flat spring 12 to easily slide between the open position and closed position upon application of manual force. The depression may be disposed on both the first portion 18 and the second portion 20 of the sensor body 14. It is contemplated that the depression 26 may be constructed from or coated with a generally smooth material, such as plastic, to reduce the frictional resistance of the depression 26 against the flat spring 12 as the flat spring 12 moves between the open position and the closed position. As the sensor body 14 may be relatively thinner in the area of a depression 26, it may be advantageous to provide additional support structures disposed on or near the depression 26 designed to cushion the patient tissue from possible discomfort caused by the spring force of the flat spring 12.

[0040] FIG. 1C is an alternate embodiment in which the sensor 10A may be closed with a clip 13. The clip 13 may be a removable clothespin-like structure, as depicted, or other structure that may be opened to accommodate the sensor body 14, and closed to provide a closing bias to the first portion 18 and the second portion 20. For example, in certain embodiments, a hinged clip (not shown) may be applied to the sensor body 14. In certain embodiments, it may be desirable to affix the sensor 10A to the patient with multiple clips 13 to provide the appropriate closing force at multiple points on the patient's tissue.

[0041] FIG. 2 depicts an alternate embodiment of a sensor 10B applied to a patient digit 28 in which a flat spring 30 may be configured to slide along the sensor body 32 on an imaginary axis 34 that is orthogonal to the digit 28. Such an embodiment may be advantageous if a patient experiences discomfort from an alternate sensor arrangement. The flat spring 30 as arranged in the sensor 10B may provide pressure to the tissue in a manner which is more comfortable for the patient. It is contemplated that, in certain embodiments, the flat spring 30 may be arranged along the sensor body 32 in a variety of positions in order to maximize patient comfort.

[0042] In certain embodiments, it may be advantageous to provide additional guides or restraints to prevent the flat spring from detaching itself from the sensor body during normal use. FIG. 3 illustrates a sensor 10C with a restraining clip 34. The restraining clip 34 is disposed on the sensor body 36 over a depression 38, such that the flat spring 40 slides underneath the restraining clip 34 as it moves from the open position to the closed position. The flat spring 40 may also optionally include a guard 42 disposed on the side 44 of the flat spring 40 that contacts the restraining clip 34 during normal use. The guard 42 is configured to collide with the restraining clip 34 when the flat spring 40 is moved to the open position. The guard 42 prevents further movement of the flat spring 40 along the sensor body 36, and hence prevents the flat spring 40 from being pulled off entirely. The restraining clip 34 and guard 42 may prevent a healthcare worker from inadvertently applying an excess of manual force and pulling the flat spring 40 off the sensor body 36 when moving the flat spring 40 to the open position. In certain embodiments (not shown), the restraining clip 34 may be removable in order to detach the flat clip 40 completely from the sensor body 36. For example, it may be advantageous to remove the flat spring 40 from the sensor body 36 to allow the sensor body 36 to be cleaned.

[0043] In general, a sensor body (e.g. sensor body 14, 32, 36, 50, or 56) as described herein may be easily maintained, cleaned, and/or disinfected by immersing the sensor into a disinfectant or cleaning solution or by rinsing the sensor body off, such as under running water. Furthermore, a sensor body as provided herein has a generally simple topography, and may be constructed or molded from a single part. Thus, the sensor body may be free of the irregularities typically associated with a complex multi-part construction which may normally allow the accumulation of biological detritus or residue.

[0044] In certain embodiments, the sensors provided by the present techniques may be used on patients with a variety of physiologies, such as fingers of varying sizes. Thus, as it is envisioned that a single sensor may be appropriate for use on many different patients, it may be advantageous to provide additional fitting components to ensure that the light emitting and detecting components of the sensor are generally positioned in comparable locations on one patient's tissue as compared to another patient. FIG. 4 illustrates a perspective side view of a sensor 10D with a finger stop 46 on the tissue-contacting surface 48 of the sensor body 50. When a digit is inserted into the sensor 10D, the tip of the digit may be prevented from inserting any further within the sensor body 50 by the finger stop 46. When the digit is inserted as far as possible, the flat spring 51 may then slide into the engaged position to secure the sensor 10D onto the

digit. The finger stop **46** will be generally disposed on the tissue-contacting surface **48** of the sensor body **50** to position the emitter **52** and the detector **54** at the desired spot on the patient's tissue.

[0045] In certain embodiments, it may be advantageous to embed a sliding clip, such as a flat spring, in the sensor body when the sensor is in the closed position. Such an exemplary sensor **10E** is illustrated in FIG. **5A**, which depicts an overmolded sensor body **56**. FIG. **5B** is a cross-sectional view in which an internal frame **58** of the overmolded sensor body **56** is visible. The internal frame **58** provides a skeletal, internal framework for a pulse oximetry sensor **10E**. Such a skeletal framework provides structural support for a coating or overmolding. In addition, the internal frame **58** provides support and framework for openings **59** in the overmolded sensor body **56** into which a flat spring **60** may slide. The flat spring **60** is in the closed position, as shown in FIG. **5A**, when mostly embedded in the overmolded sensor body **56**. When the flat spring **60** is embedded in the overmolded sensor body **56**, some sharp edges or corners may be shielded from the patient, and thus the sensor **10E** may be more comfortable. It may be also advantageous to include a handle **62** on the flat spring **60** in order to allow the flat spring **60** to be more easily grasped by a user.

[0046] In certain embodiments, the internal frame **58** is constructed, in whole or in part, from polymeric materials, such as thermoplastics, or from other suitably rigid or semi-rigid materials, such as stainless steel, aluminum, magnesium, or other metals or alloys which are sufficiently ductile and/or strong. The sensor **10E** may be overmolded over the internal frame **58** by an injection molding process. In one example of such a process the internal frame **58** may be positioned within a die or mold of the desired shape for the sensor **10E**. The molten or otherwise unset overmold material may then be injected into the die or mold. In certain embodiments, other sensor components, such as the emitter **64** and/or detector **66**, may be attached or inserted into their respective housings or positions on the overmolded sensor body. Alternatively, the optical components (such as emitter **64** and detector **66**) and/or conductive structures (such as wires or flex circuits) may be placed on the internal frame **58** prior to overmolding.

[0047] In one implementation, the sensor body as described herein (e.g. sensor body **14**, **32**, **36**, **50**, or **56**) may be constructed, either wholly or in part, from a thermoplastic elastomer or other conformable material. In such an embodiment, the conformable nature of the sensor body may serve to accommodate a wide variety of patient tissue sizes. The thermoplastic elastomer may include compositions such as thermoplastic polyolefins, thermoplastic vulcanizate alloys, silicone, polyurethane, and so forth. In one embodiment, the sensor body is constructed from polyurethane having a durometer of 15 Shore A. As will be appreciated by those of ordinary skill in the art, the sensor body may vary, depending on the varying degrees of conformability, durability, wettability, or other physical and/or chemical traits that are desired. Indeed, the sensor body may be selected to provide additional spring force to that provided by a sliding clip or spring, resulting in a combined spring force which includes the force provided by the flat spring and the force provided by the sensor body.

[0048] In certain embodiments, the sensor body is formed as a single molded part configured with housings or other

structures designed to accommodate the sensor optics. For example, a sensor body as described herein may be configured to include an emitter housing and a detector housing that provide precise positioning of the emitter and detector units when inserted into their respective housings. The sensor body may also provide surfaces, openings, and/or structures for securing conductors (such as wires or flex circuits) that attach to the emitter and/or detector units upon assembly. The sensor body also may provide an external cable guide through which a cable, such as an electrical or optical cable, may pass to connect to the electrical or optical conductors attached to the emitter and/or detector units upon assembly.

[0049] A sensor body as described herein may substantially U-shaped or clamshell-shaped. However, it is envisioned that the sensor body may assume any suitable configuration. For example, the sensor body may employ a living hinge in order to allow promote the movement of the first portion and the second portion relative to one another as the sensor moves between the closed position and the open position. Further, in certain embodiments (not shown), it may be advantageous for the sensor body to form a sleeve-like structure into which a digit may be inserted. Such a configuration may prevent light from leaking into the sides of a sensor.

[0050] A flat spring, torsional spring, clip, or other biasing component (e.g. flat spring **12**, **30**, **40**, **51**, or **60**) as described herein may be constructed from a variety of materials or combinations of materials that provide the desired resiliency and clamping force. For example, in certain embodiments, a flat spring is constructed from stainless steel. In other embodiments, the flat spring **32** is constructed from polymeric materials, such as plastics.

[0051] In certain embodiments, it is contemplated that the clip or other closing mechanism has sufficient pressure so that it exceeds the typical venous pressure of a patient, but does not exceed the diastolic arterial pressure. A sensor that applies a pressure greater than the venous pressure will squeeze excess venous blood from the optically probed tissue, thus enhancing the sensitivity of the sensor to variations in the arterial blood signal. Since the pressure applied by the sensor is designed to be less than the arterial pressure, the application of pressure to the tissue does not interfere with the arterial pulse signal. Typical venous pressure, diastolic arterial pressure and systolic arterial pressure are less than 10-35 mmHg, 80 mmHg, and 120 mmHg, respectively. In certain embodiments, the sensor may be adjusted to overcome an average pressure of 15-30 mmHg. These pressures may vary because of the location of the vascular bed and the patient's condition. In other embodiments, low arterial diastolic blood pressure (about 30 mmHg) may occur in sick patients. In such embodiments, the sensor may remove most of the venous pooling with light to moderate pressure (to overcome about 15 mmHg). It is contemplated that removing venous blood contribution without arterial blood exsanguination may improve the arterial pulse signal.

[0052] Although the exemplary sensors described herein have depicted a generally U-shaped flat spring, it should be understood that a sliding clip may be a spring or any other biasing mechanism. Further, the clip may be any suitable size or shape appropriate for closing a sensor body around a patient's tissue.

[0053] In certain embodiments, it may be advantageous to use a single sliding clip configured to be used in conjunction with a variety of different sensor bodies. For example, a detachable sliding clip, such as a flat spring, may be detached from a sensor body adapted to be applied to a patient's digit, and may be then used with a sensor body adapted to be applied to a patient's earlobe. For example, in certain embodiments, pulse oximetry sensor kits may include several sensor bodies, each adapted for a different tissue or digit, and a single sliding clip that is suitably sized and shaped to be used with each of the sensor bodies.

[0054] In an alternate embodiment, it may be advantageous to use a single sensor body with a variety of clips of different sizes. For example, a single sensor body may be arranged to fit on a patient's finger and may be clipped with a first clip. The same sensor body may then be used on a larger patient's finger with a second, larger clip that accommodates the larger tissue. The clips may be selected to be of multiple sizes and/or strengths to provide suitable closing bias and securing strength. For example, a sensor body may be provided with a first clip configured to overcome a normal venous pressure of 15-30 mmHg. The sensor body may also be provided with a second clip that is more appropriate for use with very sick patients that exhibit overall lower blood pressures. The second clip may be configured to overcome lower venous pressures of less than 15 mmHg. In certain embodiments, pulse oximetry sensor kits may include several clips, each adapted for a different tissue or digit, and a single sensor body that is suitably sized and shaped to be used with each of the various clips.

[0055] Keeping in mind the preceding points, the exemplary sensor designs herein are provided as examples of sensors that provide a conformable and secure fit over a variety of patient physiologies. It should be appreciated that a sensor 10 according to the present teachings may be adapted for use on any digit, and may also be adapted for use on a nose bridge, foot, earlobe, or other sensor site.

[0056] A sensor, illustrated generically as a sensor 10, may be used in conjunction with a pulse oximetry monitor 68, as illustrated in FIG. 7. It should be appreciated that the cable 70 of the sensor 10 may be coupled to the monitor 68 or it may be coupled to a transmission device (not shown) to facilitate wireless transmission between the sensor 10 and the monitor 68. The monitor 68 may be any suitable pulse oximeter, such as those available from Nellcor Puritan Bennett Inc. Furthermore, to upgrade conventional pulse oximetry provided by the monitor 68 to provide additional functions, the monitor 68 may be coupled to a multi-parameter patient monitor 72 via a cable 74 connected to a sensor input port or via a cable 76 connected to a digital communication port.

[0057] The sensor 10 includes an emitter 78 and a detector 80 that may be of any suitable type. For example, the emitter 78 may be one or more light emitting diodes adapted to transmit one or more wavelengths of light in the red to infrared range, and the detector 80 may be a photodetector selected to receive light in the range or ranges emitted from the emitter 78.

[0058] The emitter 78 and the detector 80 may be disposed on a sensor body 82, which may be made of any suitable material, such as plastic, rubber, silicone, foam, woven material, or combination thereof. Alternatively, the emitter

78 and the detector 80 may be remotely located and optically coupled to the sensor 10 using optical fibers. In the depicted embodiments, the sensor 10 is coupled to a cable 70 that is responsible for transmitting electrical and/or optical signals to and from the emitter 78 and detector 80 of the sensor 10. The cable 70 may be permanently coupled to the sensor 10, or it may be removably coupled to the sensor 10—the latter alternative being more useful and cost efficient in situations where the sensor 10 is disposable.

[0059] The sensor 10 may be a "transmission type" sensor. Transmission type sensors include an emitter 78 and detector 80 that are typically placed on opposing sides of the sensor site. If the sensor site is a fingertip, for example, the sensor 10 is positioned over the patient's fingertip such that the emitter 78 and detector 80 lie on either side of the patient's nail bed. In other words, the sensor 10 is positioned so that the emitter 78 is located on the patient's fingernail and the detector 80 is located 180° opposite the emitter 78 on the patient's finger pad. During operation, the emitter 78 shines one or more wavelengths of light through the patient's fingertip and the light received by the detector 80 is processed to determine various physiological characteristics of the patient. In each of the embodiments discussed herein, it should be understood that the locations of the emitter 78 and the detector 80 may be exchanged. For example, the detector 80 may be located at the top of the finger and the emitter 78 may be located underneath the finger. In either arrangement, the sensor 10 will perform in substantially the same manner.

[0060] For pulse oximetry applications using either transmission or reflectance type sensors the oxygen saturation of the patient's arterial blood may be determined using two or more wavelengths of light, most commonly red and near infrared wavelengths. Similarly, in other applications a tissue water fraction (or other body fluid related metric) or a concentration of one or more biochemical components in an aqueous environment may be measured using two or more wavelengths of light, most commonly near infrared wavelengths between about 1,000 nm to about 2,500 nm. It should be understood that, as used herein, the term "light" may refer to one or more of infrared, visible, ultraviolet, or even X-ray electromagnetic radiation, and may also include any wavelength within the infrared, visible, ultraviolet, or X-ray spectra.

[0061] Although the embodiments described herein generally referred to transmission type sensors, it should be understood that the sensor 10 may be a reflectance type sensor. Reflectance type sensors generally operate under the same general principles as transmittance type sensors. However, reflectance type sensors include an emitter 78 and detector 80 that are typically placed on the same side of the sensor site. For example, a reflectance type sensor may be placed on a patient's fingertip or forehead such that the emitter 78 and detector 80 lie side-by-side. Reflectance type sensors detect light photons that are scattered back to the detector 80.

[0062] While the pulse oximetry sensor 10 discussed herein is one example of an exemplary medical device, other such devices are also contemplated and fall within the scope of the present disclosure. For example, other medical sensors and/or contacts applied externally to a patient may be advantageously applied using a clip-style sensor body as discussed herein. Examples of such sensors or contacts may

include glucose monitors or other sensors or contacts which are generally held adjacent to the skin of a patient such that a conformable and comfortable fit is desired.

[0063] While the invention may be susceptible to various modifications and alternative forms, specific embodiments have been shown by way of example in the drawings and have been described in detail herein. However, it should be understood that the invention is not intended to be limited to the particular forms disclosed. Indeed, the present techniques may not only be applied to measurements of blood oxygen saturation, but these techniques may also be utilized for the measurement and/or analysis of other blood constituents. For example, using the same, different, or additional wavelengths, the present techniques may be utilized for the measurement and/or analysis of carboxyhemoglobin, methemoglobin, total hemoglobin, intravascular dyes, and/or water content. The invention is to cover all modifications, equivalents, and alternatives falling within the spirit and scope of the invention as defined by the following appended claims.

What is claimed is:

1. A sensor, comprising:
 - a sensor body comprising a first portion and a second portion;
 - at least one sensing element disposed on the sensor body; and
 - a sliding clip adapted to slide along the sensor body to bias the first portion towards the second portion.
2. The sensor, as set forth in claim 1, wherein the sliding clip comprises a flat spring.
3. A sensor, comprising:
 - a sensor body comprising a first portion and a second portion;
 - at least one sensing element disposed on the sensor body; and
 - a sliding mechanism adapted to move between an engaged position and a disengaged position, wherein the first portion and the second portion are biased towards one another when the sliding mechanism is in the engaged position.
4. The sensor, as set forth in claim 3, wherein the sensor comprises at least one of a pulse oximetry sensor or a sensor for measuring a water fraction.
5. A pulse oximetry system, comprising:
 - a pulse oximeter monitor; and
 - a pulse oximetry sensor configured to communicate with the pulse oximetry monitor, the pulse oximetry sensor comprising:
 - a sensor body comprising a first portion and a second portion;
 - at least one sensing element disposed on the sensor body; and
 - a sliding clip adapted to slide along the sensor body to bias the first portion towards the second portion.
6. The pulse oximetry system, as set forth in claim 5, wherein the sensing element comprises an emitter and a detector.
7. A method of manufacturing a sensor, comprising:
 - providing a sensor body comprising a first portion and a second portion and having at least one sensing element disposed thereon; and
 - providing a sliding clip adapted to slide along the sensor body to bias the first portion towards the second portion.
8. The method, as set forth in claim 7, comprising:
 - providing a retaining element configured to attach the sliding clip to the sensor body.
9. A method of applying a sensor, comprising:
 - inserting a patient's tissue into a sensor body comprising at least one sensing element; and
 - sliding a clip into an engaged position.
10. The method, as set forth in claim 9, comprising:
 - embedding the clip in the sensor body.
11. A pulse oximetry sensor kit, comprising:
 - a first sensor body having a first size, the first sensor body comprising:
 - a first portion and a second portion;
 - at least one sensing element disposed on the first sensor body;
 - a second sensor body having a second size, the second sensor body comprising:
 - a first portion and a second portion;
 - at least one sensing element disposed on the second sensor body; and
 - at least one detachable clip, wherein the detachable clip is adapted to slide along the first sensor body or the second sensor body.
 - 12. The kit, as set forth in claim 11, wherein the first size and the second size are different from one another.
 - 13. A pulse oximetry sensor kit, comprising:
 - at least one sensor body comprising:
 - a first portion and a second portion;
 - at least one sensing element disposed on the sensor body;
 - a first detachable clip having a first size, wherein the detachable clip is adapted to bias the first portion towards the second portion; and
 - a second detachable clip having a second size, wherein the second detachable clip is adapted to bias the first portion towards the second portion.
 - 14. The kit, as set forth in claim 13, wherein the first sensor body is adapted for use on a first tissue and the second sensor body is adapted for use on a second tissue.
 - 15. A sensor, comprising:
 - a sensor body comprising a first portion and a second portion;
 - at least one sensing element disposed on the sensor body; and
 - a detachable clip adapted to bias the first portion towards the second portion.

16. The sensor, as set forth in claim 15, wherein the detachable clip comprises a hinge.

17. A pulse oximetry system, comprising:

a pulse oximeter monitor; and

a pulse oximetry sensor configured to communicate with the pulse oximetry monitor, the pulse oximetry sensor comprising:

a sensor body comprising a first portion and a second portion;

at least one sensing element disposed on the sensor body; and

a detachable clip adapted to bias the first portion towards the second portion.

18. The pulse oximetry system, as set forth in claim 17, wherein the sensing element comprises an emitter and a detector.

19. A method of manufacturing a sensor, comprising:

providing a sensor body comprising a first portion and a second portion and having at least one sensing element disposed thereon; and

providing a detachable clip adapted to bias the first portion towards the second portion.

20. The method, as set forth in claim 19, comprising:

providing a depression in the sensor body.

21. A method of applying a sensor, comprising:

inserting a patient's tissue into a sensor body having a first portion and a second portion and at least one sensing element; and

applying a detachable clip to the sensor body to bias the first portion towards the second portion.

22. The method, as set forth in claim 21, comprising:

closing the detachable clip at a hinge.

* * * * *

专利名称(译)	夹式医疗传感器及其使用技术		
公开(公告)号	US20070078315A1	公开(公告)日	2007-04-05
申请号	US11/239809	申请日	2005-09-30
[标]申请(专利权)人(译)	KLING CARL PALMER PHILLIP小号 FLAGLER ROBERTW		
申请(专利权)人(译)	KLING CARL PALMER PHILLIP小号 FLAGLER ROBERTW		
当前申请(专利权)人(译)	COVIDIEN LP		
[标]发明人	KLING CARL PALMER PHILLIP S FLAGLER ROBERT W		
发明人	KLING, CARL PALMER, PHILLIP S. FLAGLER, ROBERT W.		
IPC分类号	A61B5/00		
CPC分类号	A61B5/02427 A61B5/14552 A61B5/6816 A61B5/6826 A61B5/6829 A61B5/6838		
其他公开文献	US7881762		
外部链接	Espacenet USPTO		

摘要(译)

提供了一种夹式传感器，其包括滑动夹，例如沿传感器滑动的扁平弹簧，以为传感器提供闭合力。当滑动夹子接合时，传感器固定到患者身上。传感器可以放置在患者的手指，脚趾，耳朵等上，以获得脉搏血氧测量法或其他分光光度测量值。

