



US 20070060824A1

(19) **United States**

(12) **Patent Application Publication**

Lam et al.

(10) **Pub. No.: US 2007/0060824 A1**

(43) **Pub. Date: Mar. 15, 2007**

(54) **COMBINED COMPUTER MOUSE AND BLOOD PRESSURE SPHYGMOMANOMETER**

(52) **U.S. Cl.** 600/485; 600/490; 600/300; 600/549; 600/309; 600/345; 600/547

(76) **Inventors: Phillip L. Lam**, Monterey Park, CA (US); **Ping Cheng Benjamin Liu**, San Gabriel, CA (US)

(57) **ABSTRACT**

Correspondence Address:
LEONARD TACHNER, A PROFESSIONAL LAW CORPORATION
17961 SKY PARK CIRCLE, SUITE 38-E
IRVINE, CA 92614

A sphygmomanometer cuff assembly, air pump, pressure sensor and release valve are contained in an otherwise conventional computer mouse controller. Three alternative embodiments are illustrated and discussed herein. In one such embodiment the sphygmomanometer cuff is nominally positioned within the mouse structure and is extended outside the mouse housing during the measurement. In another embodiment, the cuff is always external of the mouse structure and is easily connected to the mouse at special ports during the measurement. In yet another embodiment, the cuff is always internal of the mouse structure and is readily accessible through an aperture in the housing surface of the mouse to permit the measurement to take place. Preferably, in each of these alternative embodiments a hinged or slidable door or panel protects the cuff or cuff ports between measurements. In all of the embodiments shown herein, the sphygmomanometer cuff is configured for receiving a human finger in circumambient pressured engagement using controlled air pressure to vary the cuff/finger engagement pressure in a precise manner.

(21) **Appl. No.: 11/418,639**

(22) **Filed: May 5, 2006**

Related U.S. Application Data

(62) Division of application No. 11/215,983, filed on Aug. 31, 2005, now Pat. No. 7,066,890.

Publication Classification

(51) **Int. Cl.**
A61B 5/02 (2006.01)
A61B 5/00 (2006.01)
A61B 5/05 (2006.01)

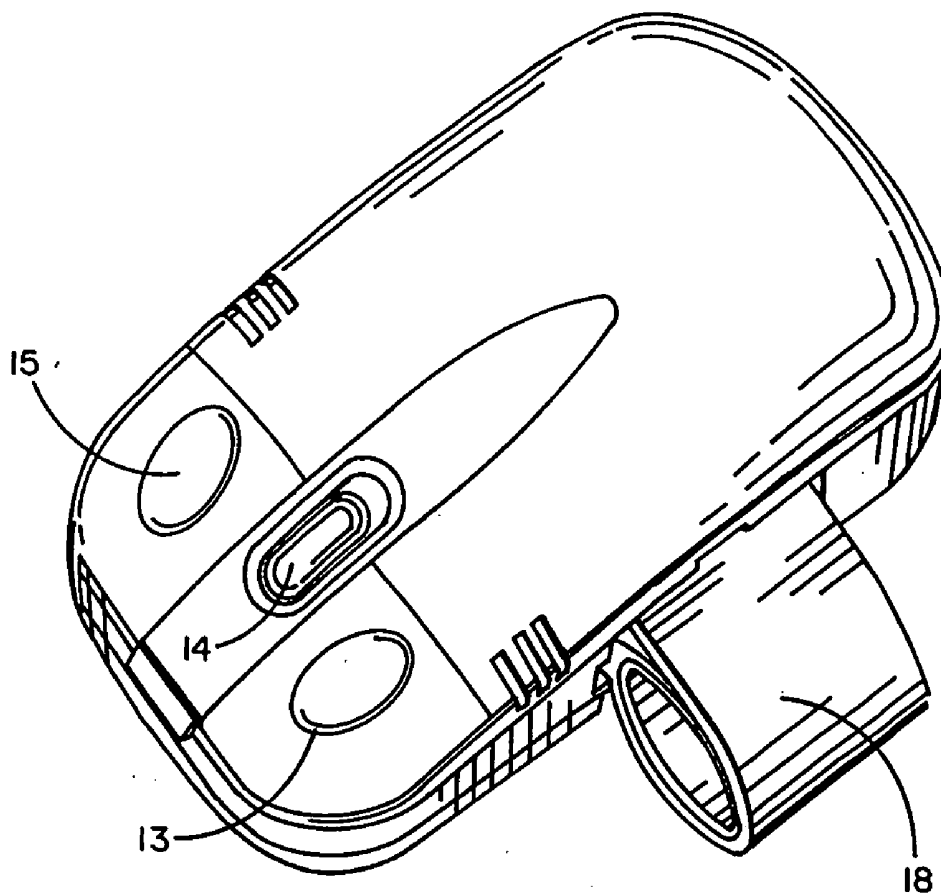

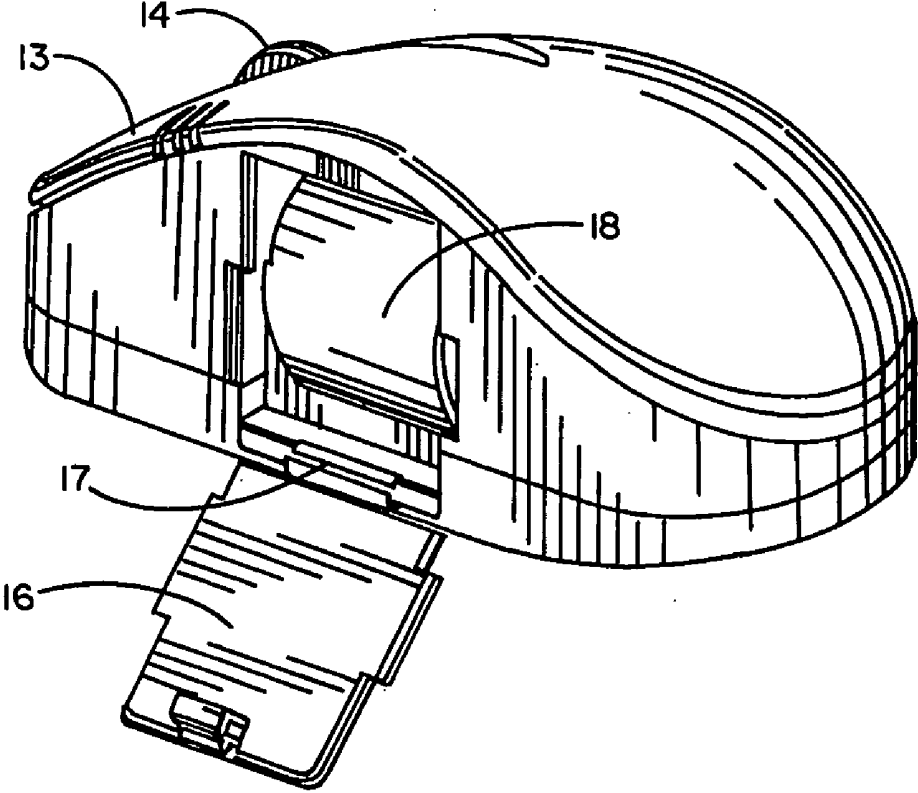
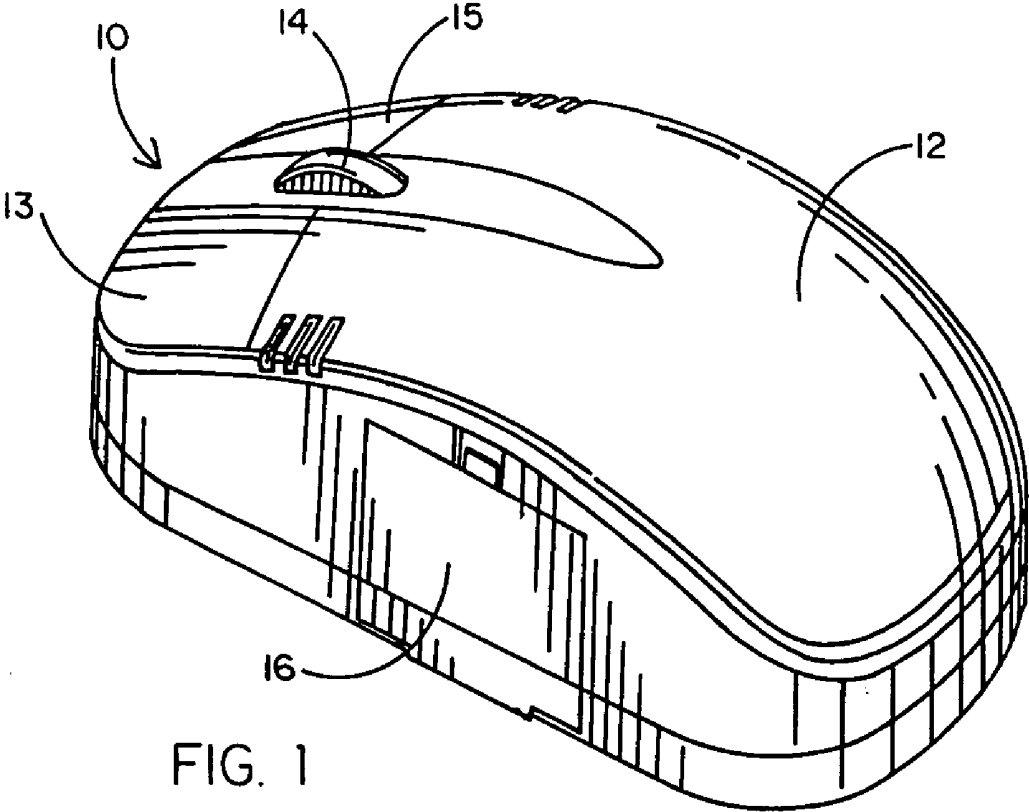

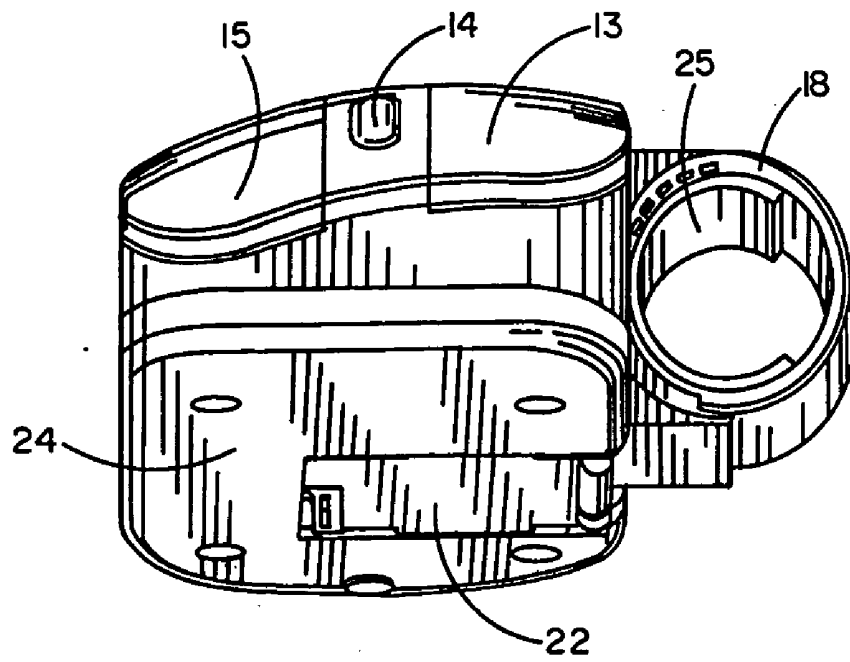
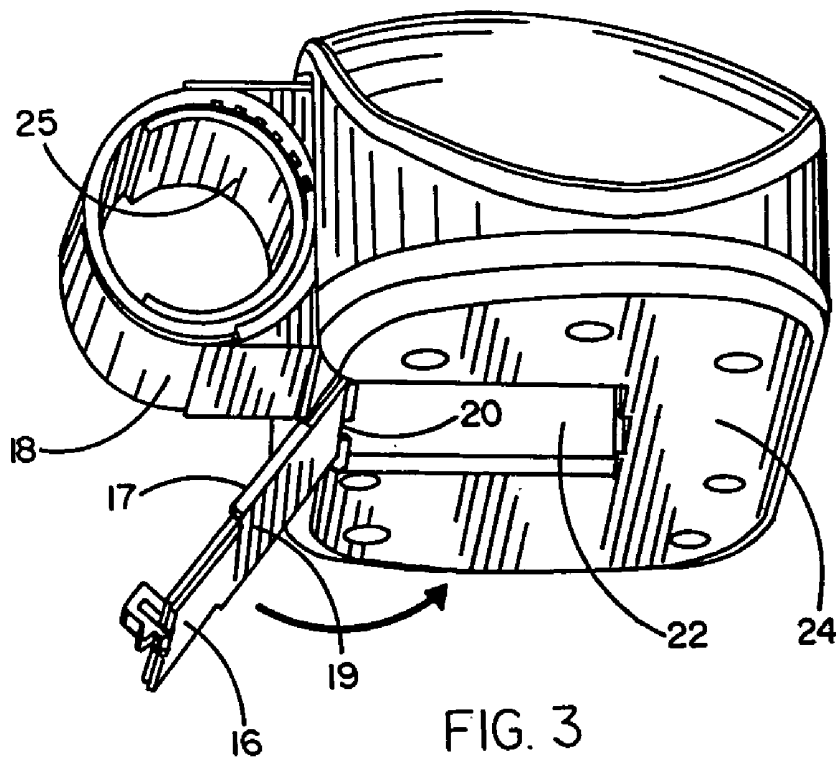

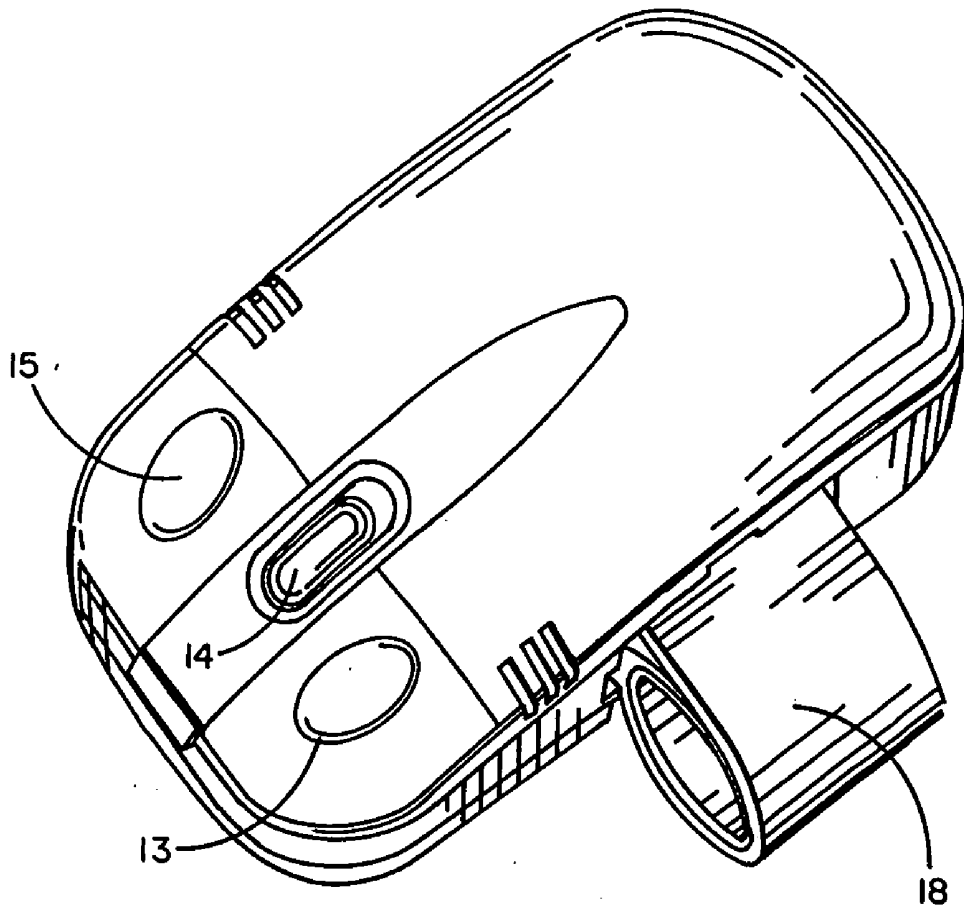

FIG. 5

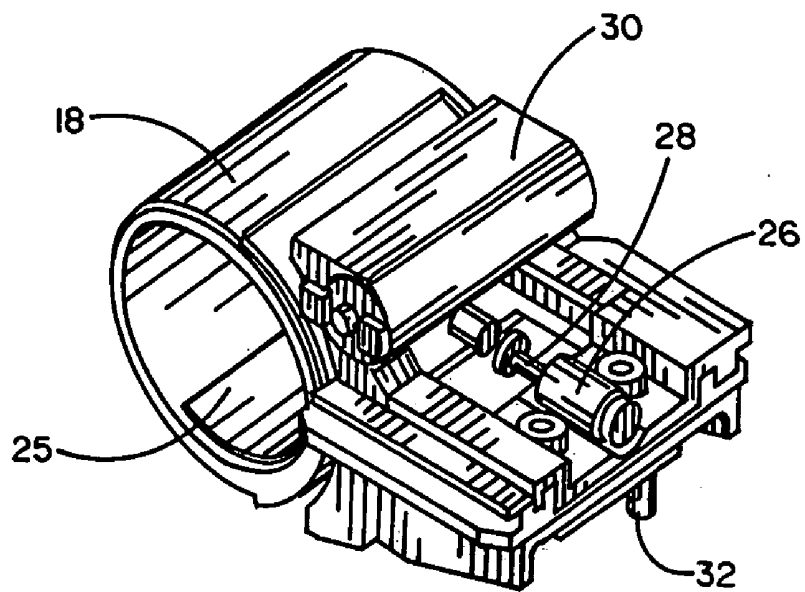

FIG. 7

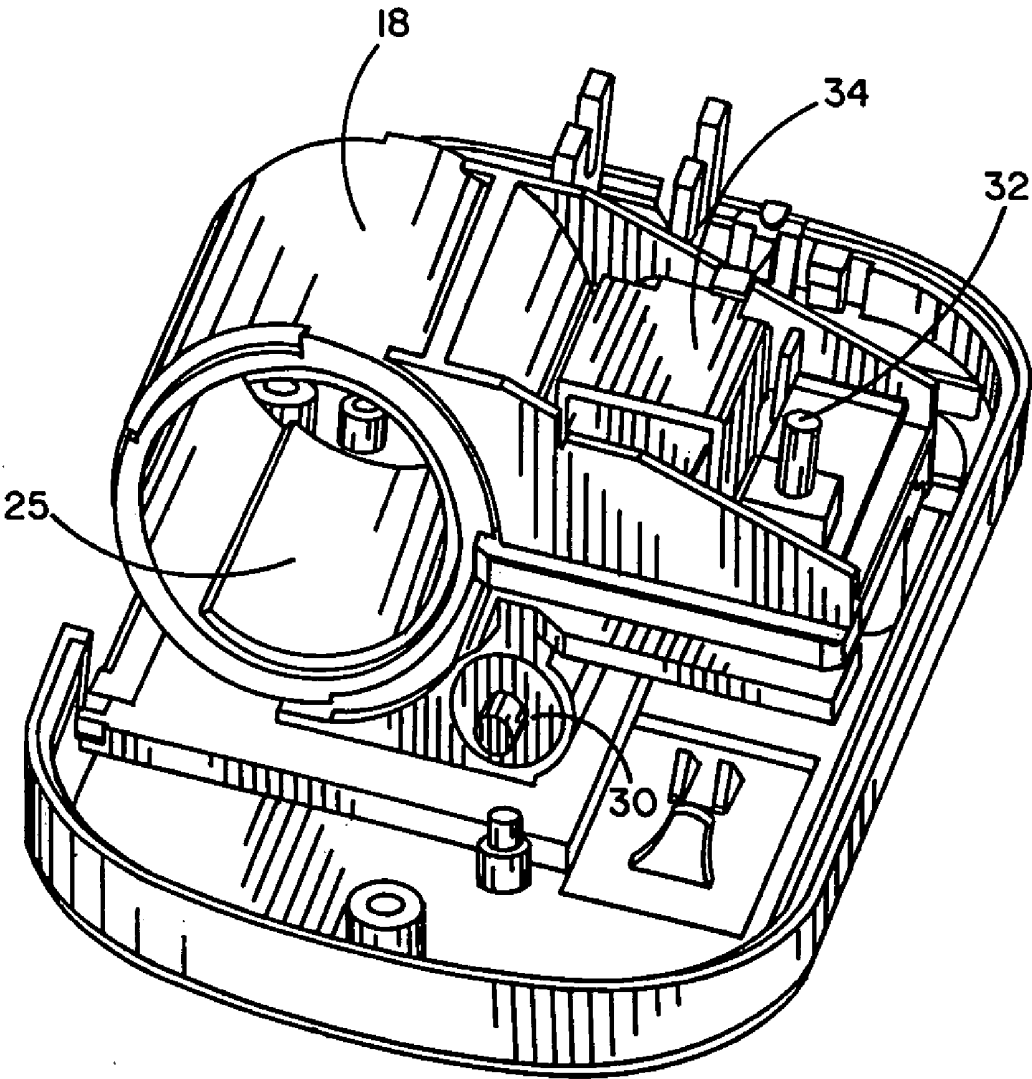

FIG. 6

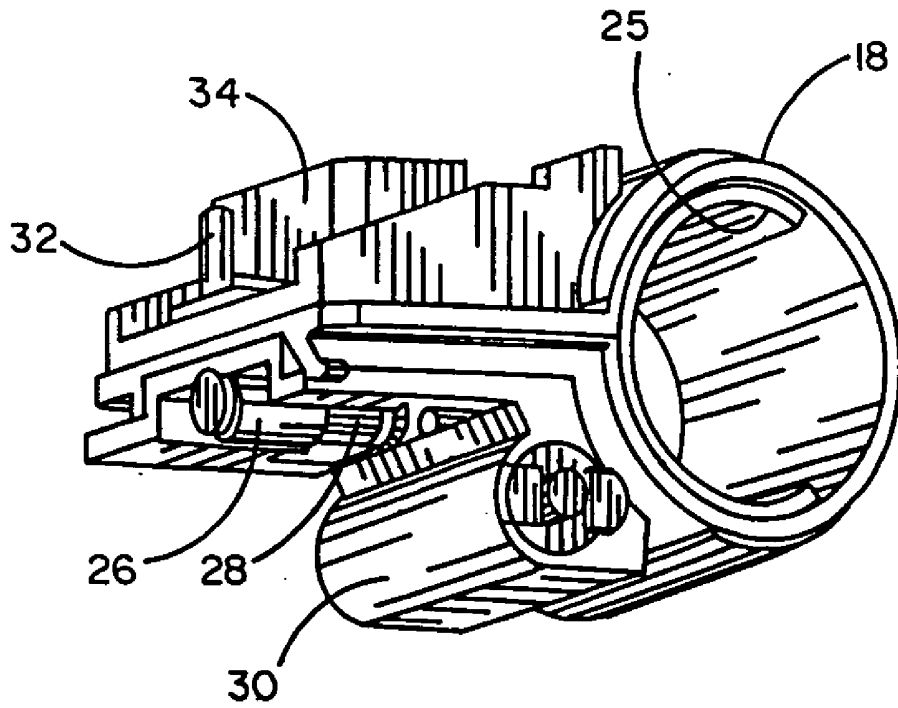

FIG. 8

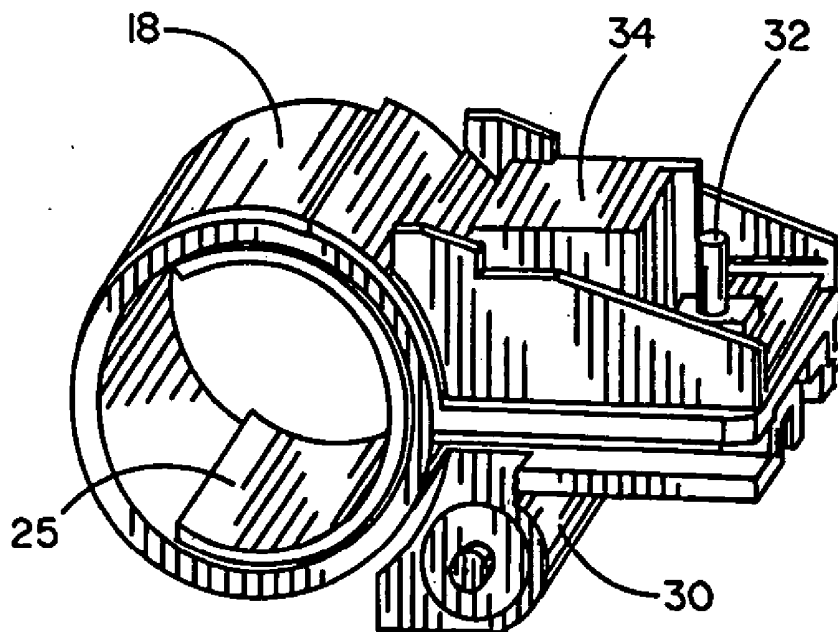

FIG. 9

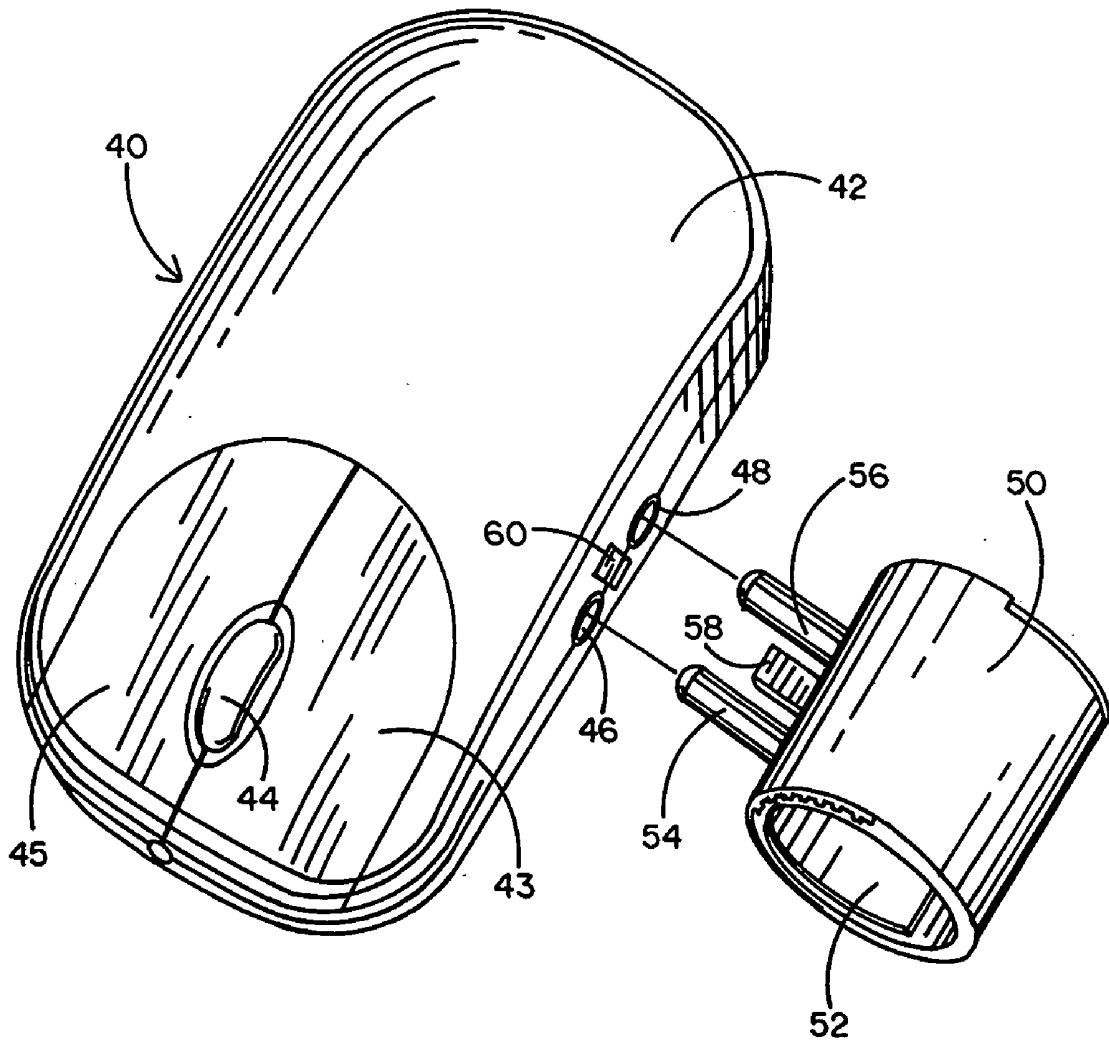

FIG. 10

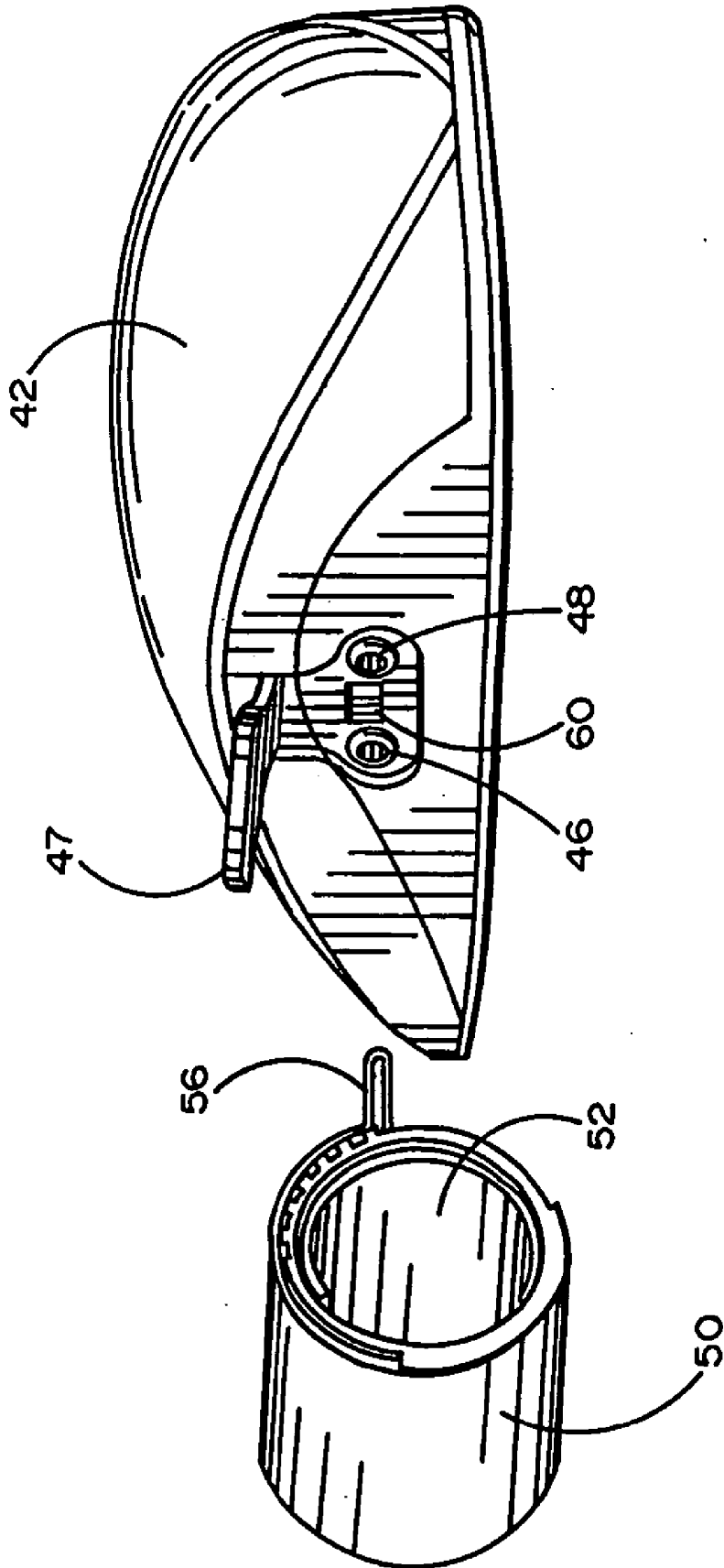

FIG. 11

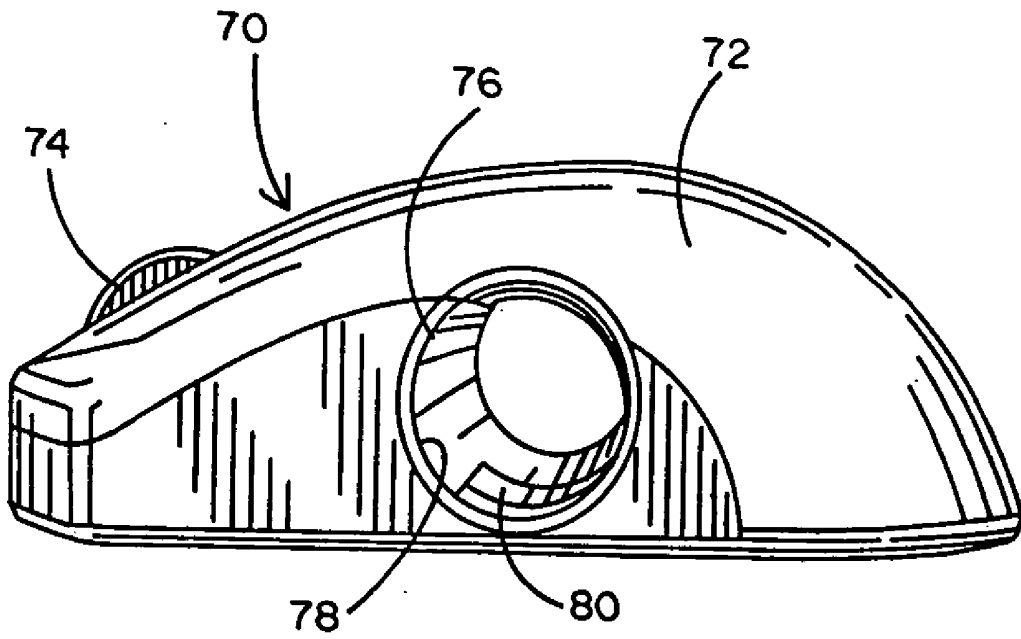

FIG. 12

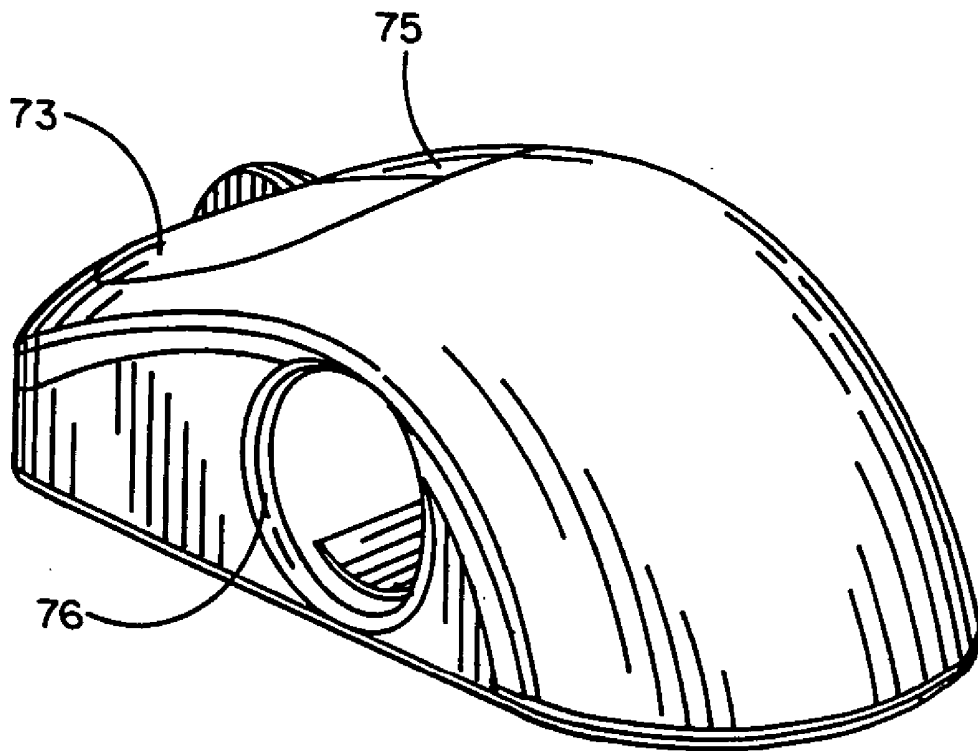

FIG. 13

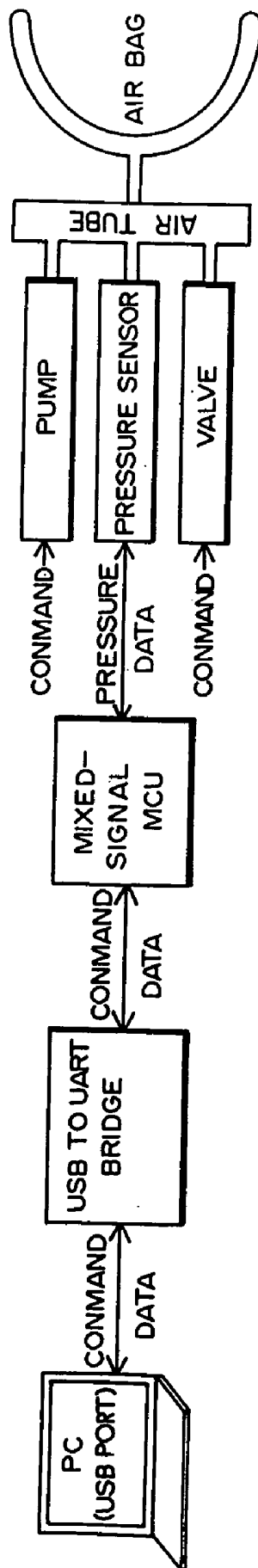

FIG. 14

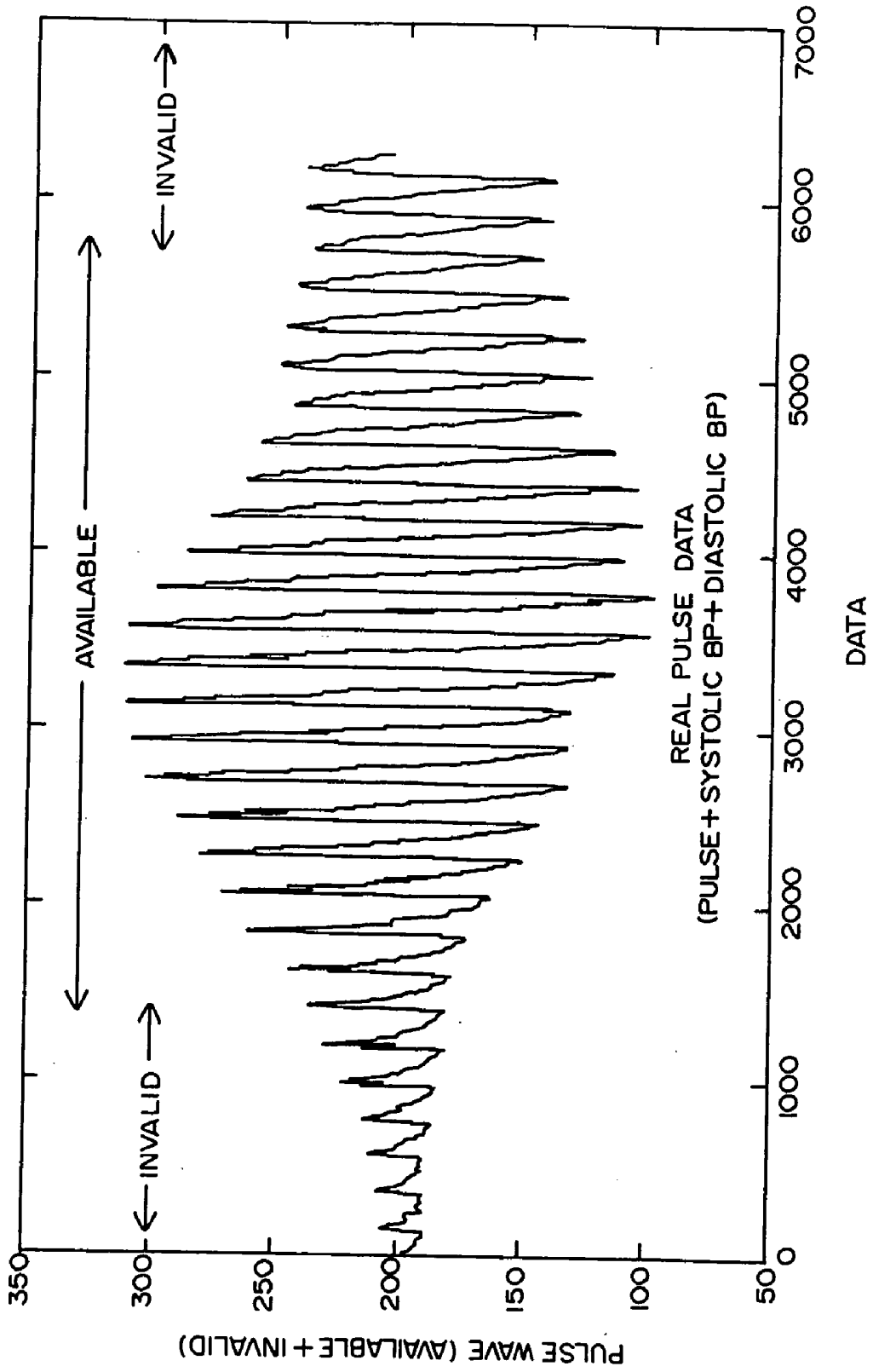

FIG. 15

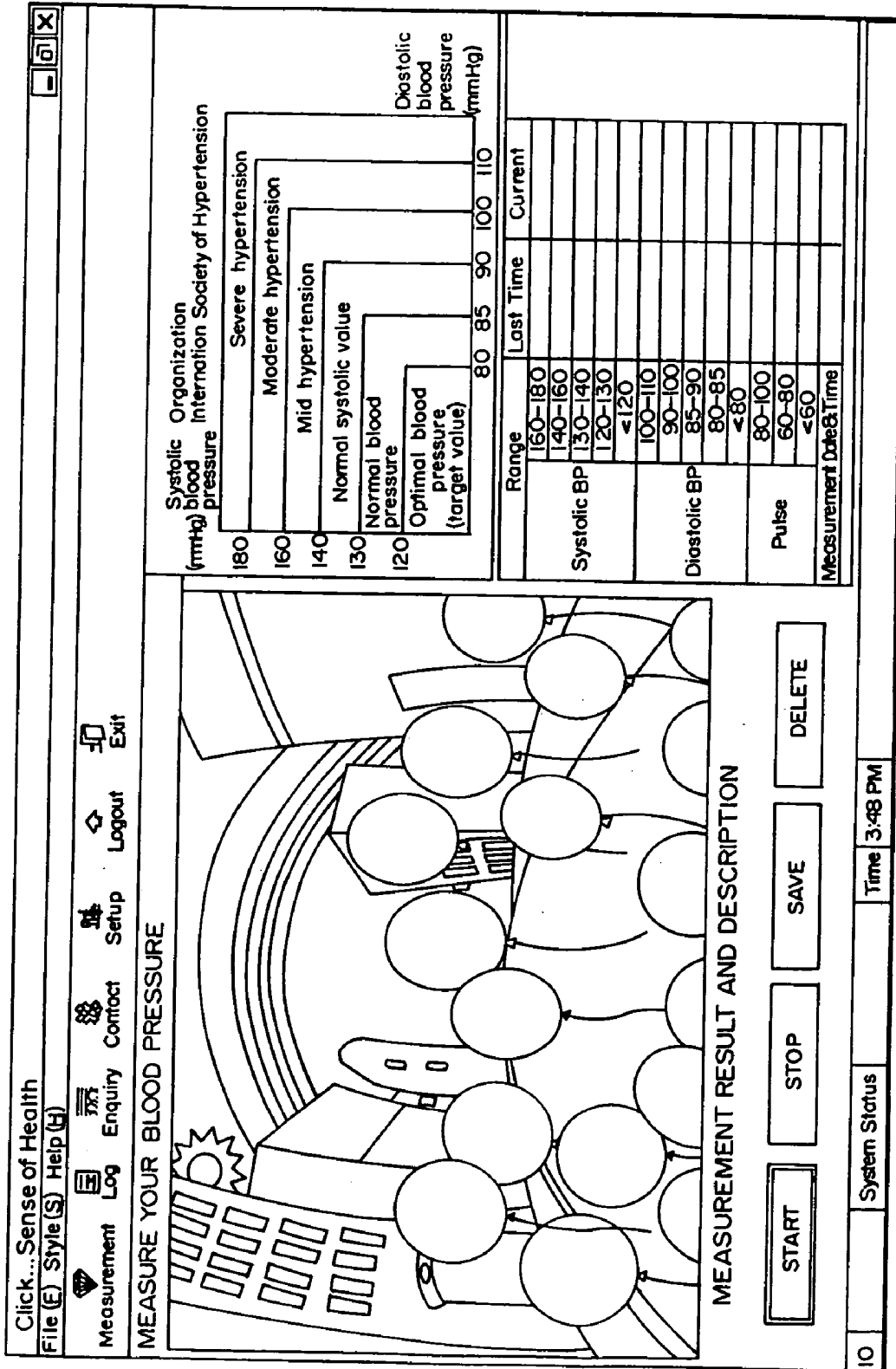

FIG. 16

COMBINED COMPUTER MOUSE AND BLOOD PRESSURE SPHYGMOMANOMETER

CROSS-REFERENCE TO RELATED APPLICATIONS

[0001] This application is a divisional of U.S. patent application Ser. No. 11/215,983 filed Aug. 31, 2005 and now issued U.S. Pat. No. _____.

BACKGROUND OF THE INVENTION

[0002] 1. Field of the Invention

[0003] The present invention relates generally to blood pressure monitoring devices. More specifically, the invention hereof relates to a computer mouse controller which incorporates a blood pressure finger cuff for monitoring blood pressure and transmitting measured data to the computer with which the mouse is associated. Such data is then displayed on the display of the computer to provide an easily understood representation of the measured parameters.

[0004] 2. Background Art

[0005] Hypertension is one of modern society's most insidious diseases. Left untreated, it causes life-threatening problems including atherosclerosis, strokes and aneurysms. Long-term hypertension can result in diminished cardiovascular and kidney function. Yet while high blood pressure is one of the simplest problems to detect in an entirely non-invasive process, it is all too commonly undetected in a large portion of the population. In the past twenty years or so, with the advent of low-cost microprocessor chips and miniature digital electronics and electromagnetic devices, the self-measurement of blood pressure by non-medical personnel has become more readily available. Nevertheless, blood pressure sphygmomanometers are still too sophisticated for a large segment of the population. Even those who are entirely capable of operating such devices tend to put them away in drawers and other out of the way places where they often remain mostly forgotten and unused.

[0006] It would be highly advantageous to the early detection of hypertension and thus to the general health of the population if there were a way to provide prolific availability of blood pressure monitoring devices that were readily accessible and even easier to use than currently available digital sphygmomanometers. Having a blood pressure sphygmomanometer at virtually every computer with a pressure cuff always immediately adjacent to each such computer, would go a long way to serving such an advantageous function. Such is the purpose of the present invention.

SUMMARY OF THE INVENTION

[0007] The present invention combines the blood pressure sphygmomanometer with one of the most commonly available devices of the modern world, the computer mouse. Moreover, the invention incorporates the sphygmomanometer cuff into the computer mouse in a manner which makes it extremely simple and convenient to initiate and carry out the blood pressure measurement process. Three alternative embodiments are illustrated and discussed herein. In one such embodiment the sphygmomanometer cuff is nominally positioned within the mouse structure and is extended outside the mouse housing during the measurement. In another

embodiment, the cuff is always external of the mouse structure and is easily connected to the mouse at special ports during the measurement. In yet another embodiment, the cuff is always internal of the mouse structure and is readily accessible through an aperture in the housing surface of the mouse to permit the measurement to take place. Preferably, in each of these alternative embodiments a hinged or slidable door or panel protects the cuff or cuff ports between measurements. In all of the embodiments shown herein, the sphygmomanometer cuff is configured for receiving a human finger in circumambient pressured engagement using controlled air pressure to vary the cuff/finger engagement pressure in a precise manner.

[0008] In a well-known manner used in blood pressure sphygmomanometers of all kinds, the pressure of the cuff/finger engagement is initially increased until arterial vessel pulsation is beyond cutoff (total occlusion of the artery). The cuff pressure is then slowly decreased until first detection of arterial vessel pulsation (commonly known as Korotkoff Phase I). The corresponding cuff pressure at this point will be substantially equal to systolic blood pressure which is one significant parameter to be monitored. As cuff pressure continues to be decreased, arterial vessel pulsations will eventually become undetectable through the cuff because of the lack of adequate cuff pressure to sense those pulsations (commonly known as Korotkoff Phase V). The pressure of the cuff at this point will be substantially equal to diastolic blood pressure which is another significant parameter to be monitored. Moreover, the frequency of pulsations sensed between the systolic and diastolic pressures is measured and will be substantially equal to the heartbeat rate or pulse rate which is also a parameter of some significance to be monitored. These two cuff pressures and the pulsation frequency are the measured parameter data of the process and corresponding digital data are sent to the computer to which the mouse controller is associated.

[0009] Computer software, to be described herein, can then utilize this digital data (typically in binary form) to create a suitable display of the measured parameters on the computer's monitor. Other functions can also be carried out such as recording the data, graphically plotting data over numerous measurements and communicating the data to others such as by means of the internet for example by e-mail to pre-assigned medical personnel.

[0010] The principal advantage of the present invention is therefore clearly the proliferation of a simple and convenient way for the great number of computer users to have the benefits of frequent blood pressure monitoring. Moreover, because the computer mouse can normally be readily replaced in existing computers, this clearly beneficial health-related device can be enjoyed by substantially every computer user and his or her family with relatively little investment. Additionally, society as a whole will benefit from the likely increase in the early detection of hypertension and the resulting timely treatment thereof and prevention of related diseases. Thus it is believed that the present invention has the potential of leading to a profound change in both the configuration of computer mouse controllers and in the number of early detected hypertensive individuals.

BRIEF DESCRIPTION OF THE DRAWINGS

[0011] The various embodiments, features and advances of the present invention will be understood more completely

hereinafter as a result of a detailed description thereof in which reference will be made to the following drawings:

[0012] FIGS. 1 through 6 are various views of a first embodiment of the invention in which a sphygmomanometer pressure cuff is selectively ejected from within a mouse controller for blood pressure measurement;

[0013] FIGS. 7 through 9 are various views of a sphygmomanometer cuff and attendant devices for applying occluding pressure to a human finger and releasing the pressure in a precise manner for carrying out the measurement;

[0014] FIGS. 10 through 11 are views of a second embodiment of the invention in which a sphygmomanometer pressure cuff is selectively affixed to ports at the exterior of a mouse controller for the measurement;

[0015] FIGS. 12 through 13 are views of a third embodiment of the invention in which a sphygmomanometer pressure cuff is fixedly positioned within the housing of a mouse controller and is accessible through at least one aperture in the housing for the measurement;

[0016] FIG. 14 is a block diagram of the sphygmomanometer and computer interface which may be employed using an embodiment of the present invention; and

[0017] FIGS. 15 and 16 are representations of a computer monitor display of a record of blood pressure measurements.

DETAILED DESCRIPTION OF PREFERRED EMBODIMENTS

[0018] Referring to the accompanying figures and to FIGS. 1 through 6 initially, it will be seen that a first embodiment mouse controller 10 comprises a housing 12, click buttons 13 and 15 and control device 14. It will be understood that the precise configuration of the mouse controller hereof may be varied to virtually any of the many conventional designs. Therefore the shape, location and number of click buttons, the control device 14 and the shape of the housing 12 are all shown herein as illustrative only and should not be deemed limiting of the scope hereof. However, what is a significant improvement over conventional mouse controllers now follows.

[0019] As seen in FIGS. 1 and 2, a hinged door 16 is provided on the side of mouse housing 12. Hinged door 16, when opened about a hinge 17, leads to the interior of housing 12 where a sphygmomanometer 21 and its cuff assembly 18 are located. As will be hereafter more fully described, upon activation of the sphygmomanometer 21, cuff assembly 18 extends through door 16 to the exterior of the mouse housing as shown best in FIGS. 3 to 5. This extension of the cuff assembly is facilitated by folding door 16 about hinge 17 until it is in alignment with an inner door stage 19 which is, in turn, extended beyond the housing 12 and rotated about its hinge 20 until the door assembly is fully rotated about 270 degrees into a rectangular recess 22 in the bottom surface 24 of the housing as shown in FIGS. 3 and 4 in particular. When the cuff assembly 18 is fully extended into the position shown in FIG. 5, the cuff assembly is in suitable position for insertion of a person's extended finger for measurement of blood pressure and pulse rate. The assembly may then be re-inserted into the housing and the

door assembly rotated back into position for closure of the housing and normal, conventional usage of the mouse controller 10.

[0020] The sphygmomanometer 21 including pressure cuff assembly 18 is shown in FIG. 6 as it sits within the housing 12 and the cuff assembly and attendant components are shown in detail in FIGS. 7 to 9. As seen in those figures, the sphygmomanometer 21 comprises an inflatable air bag 25 within the annular interior of cuff assembly 18. Also forming sphygmomanometer 21 are solenoid 26, extender arm 28, motorized air pump 30, pressure sensor 32 and release valve 34. Solenoid 26 and extender arm 28 provide the ability to extend the cuff assembly 18 out of the housing 12 as previously described in conjunction with FIGS. 3 to 5. Air pump 30 provides the pressurized air to selectively expand air bag 25 to forcefully grasp a finger protruding through cuff assembly 18. Pressure sensor 32 senses the pressure at the air bag/finger surface interface and release valve 34 releases air from the air bag 25 at a rate that is commensurate with sensor 32 oscillometrically sensing the systolic and diastolic blood pressure at the inserted finger.

[0021] FIGS. 10 and 11 illustrate a second embodiment mouse controller 40 having a housing 42, click buttons 43 and 45 and control device 45. In this embodiment, the housing provides jacks 46 and 48 to which an external cuff assembly 50 having an air bag 52, is attached by connectors 54 and 56. A connector brace 58 mates with a brace receptacle 60 to further support the cuff assembly 50. The remaining components of the sphygmomanometer (less extender arm 28 and solenoid 26 which aren't required in this second embodiment) are interior to housing 42. Once the cuff assembly 50 is attached to the controller 40, the operation of the second embodiment is identical to that of the first embodiment 10. A jack cover 47 may be employed to protect the jacks 46 and 48 when the sphygmomanometer is not in use.

[0022] FIGS. 12 and 13 illustrate a third illustrative embodiment mouse controller 70 having a housing 72, click buttons 73 and 75 and control device 74. In this embodiment a sphygmomanometer is fully contained in a fixed position interior of housing 72 which has apertures 76 axially aligned on opposed side surfaces of the housing. Within apertures 76 is positioned a cuff assembly 78 and an air bag 80 to receive a person's finger for blood pressure and pulse rate measurement as previously described.

[0023] FIG. 14 is a block diagram of the sphygmomanometer/computer interface showing that the air bag is connected through air tubes to the pump, the pressure sensor and release valve. These components, in turn, receive commands and provide pressure data to a computer through an MCU and USB to UART bridge and the computer's USB port. FIG. 15 shows the typical data transmitted to the computer during the blood pressure measurement and from which the systolic, diastolic blood pressure and pulse rate parameters are obtained. FIG. 16 illustrates a typical display presented on the computer monitor after a measurement is completed. The data may be logged and graphically displayed over multiple measurements to provide a time-based record of changes in blood pressure and pulse rate.

[0024] It will now be understood that the present invention provides a novel, convenient way of measuring and tracking health-based parameters by utilizing a modified computer mouse controller that facilitates obtaining such parameters at virtually every computer. While various alternative embodi-

ments have been disclosed herein, other variations will now be perceived by those having the benefit of the description herein. Accordingly, the scope hereof is not limited by the illustrative features described herein, but only by the appended claims and their equivalents.

We claim:

1. A combination comprising:
 - a computer mouse controller; and
 - a device for measuring at least one parameter of a person's health status;
 - said controller having an interface for said measuring device;
 - wherein said measuring device is selectively attached to said controller during measurement of said at least one parameter;
 - a computer to which said controller is in communication for transferring data relating to said measurement.
2. The combination recited in claim 1 wherein said computer comprises a display device for displaying said data.
3. A combination comprising:
 - a computer mouse controller; and
 - a sphygmomanometer;
 - said controller having an interface with said sphygmomanometer;
 - wherein said sphygmomanometer has a pressure cuff accessible through an aperture in said controller.
4. A sphygmomanometer having a pressure cuff for selective engagement with a person's extremity for measuring a person's systolic and diastolic blood pressure; and

a computer control device having a housing, said cuff being contained within said housing, said housing having an access to said contained cuff for placing said extremity into said cuff;

wherein said access comprises an aperture in said housing.

5. A sphygmomanometer having a pressure cuff for selective engagement with a person's extremity for measuring a person's systolic and diastolic blood pressure; and
 - a computer mouse control device having a housing, said housing having at least one external port for receiving said cuff and containing at least one air pump for filling said cuff with air to compressively engage said extremity.
6. A sphygmomanometer having a pressure cuff for selective engagement with a person's finger for measuring a person's systolic and diastolic blood pressure; and
 - a computer mouse control device having a housing with at least one aperture for receiving said finger, said pressure cuff being located within said housing in proximity to said aperture for engaging said finger.
7. A computer mouse control device having a housing forming an interior chamber; and
 - a sphygmomanometer having an air pump positioned within said interior chamber of said housing for measuring a person's blood pressure using said computer mouse control device and a cuff for pressurized engagement with a person's extremity, said cuff being selectively connected to said air pump through a port in said housing.
8. The computer mouse control device recited in claim 7 further comprising a computer interface for connecting said control device to a computer having a display and wherein said measured blood pressure may be displayed on said display.

* * * * *

专利名称(译)	结合电脑鼠标和血压血压计		
公开(公告)号	US20070060824A1	公开(公告)日	2007-03-15
申请号	US11/418639	申请日	2006-05-05
[标]申请(专利权)人(译)	林菲利浦 刘平城BENJAMIN		
申请(专利权)人(译)	林菲利浦 刘平城BENJAMIN		
当前申请(专利权)人(译)	CALHEALTH INC.		
[标]发明人	LAM PHILLIP L LIU PING CHENG BENJAMIN		
发明人	LAM, PHILLIP L. LIU, PING CHENG BENJAMIN		
IPC分类号	A61B5/02 A61B5/00 A61B5/05		
CPC分类号	A61B5/6897 A61B5/02241		
外部链接	Espacenet USPTO		

摘要(译)

血压计袖带组件，气泵，压力传感器和释放阀包含在另外的传统计算机鼠标控制器中。在此示出和讨论了三个替代实施例。在一个这样的实施例中，血压计袖带名义上位于鼠标结构内并且在测量期间延伸到鼠标外壳之外。在另一个实施例中，袖带总是在鼠标结构的外部，并且在测量期间容易在特殊端口处连接到鼠标。在又一个实施例中，袖带总是在鼠标结构的内部，并且可以通过鼠标的壳体表面中的孔容易地接近，以允许进行测量。优选地，在这些替代实施例的每一个中，铰接或可滑动的门或面板在测量之间保护袖带或袖口。在本文所示的所有实施例中，血压计袖带构造使用受控的气压以环绕压力接合接收人的手指，以精确的方式改变袖带/手指接合压力。

