



US00RE42754E

(19) **United States**
(12) **Reissued Patent**
Lia et al.

(10) **Patent Number:** **US RE42,754 E**
(45) **Date of Reissued Patent:** **Sep. 27, 2011**

- (54) **BLOOD PRESSURE MEASURING APPARATUS**
- (75) Inventors: **Raymond A. Lia**, Auburn, NY (US);
Robert L. Vivenzio, Auburn, NY (US);
Dominick Danna, Syracuse, NY (US);
Raymond P. Dromms, Liverpool, NY (US);
Scott S. Stearns, Marietta, NY (US);
James M. Baxter, Jordan, NY (US)
- (73) Assignee: **Welch Allyn, Inc.**, Skaneateles Falls, NY (US)

4,549,550	A *	10/1985	Kami	600/499
4,920,971	A *	5/1990	Blessinger	600/492
5,101,830	A *	4/1992	Duffy et al.	600/499
5,396,894	A *	3/1995	Eide et al.	600/499
5,411,518	A *	5/1995	Goldstein et al.	606/202
5,413,582	A *	5/1995	Eaton	606/202
5,966,829	A *	10/1999	Lia et al.	33/556
6,036,718	A *	3/2000	Ledford et al.	606/202
6,120,458	A *	9/2000	Lia et al.	600/490
6,168,566	B1 *	1/2001	Lia et al.	600/488
6,245,024	B1 *	6/2001	Montagnino et al.	600/499
6,344,025	B1 *	2/2002	Inagaki et al.	600/490
6,422,086	B1 *	7/2002	Dromms et al.	73/715
6,682,547	B2 *	1/2004	McEwen et al.	606/202
2002/0099297	A1	7/2002	Nakagawa et al.	
2004/0083816	A1	5/2004	Lia et al.	

(21) Appl. No.: **11/205,302**

(22) Filed: **Aug. 16, 2005**

Related U.S. Patent Documents

Reissue of:

- (64) Patent No.: **6,746,406**
Issued: **Jun. 8, 2004**
Appl. No.: **10/025,159**
Filed: **Dec. 19, 2001**

- (51) **Int. Cl.**
A61B 5/00 (2006.01)
- (52) **U.S. Cl.** **600/499; 600/490**
- (58) **Field of Classification Search** **600/499**
See application file for complete search history.

(56) **References Cited**

U.S. PATENT DOCUMENTS

2,199,408	A *	5/1940	La Liberte	600/499
3,279,459	A *	10/1966	Schenker	600/499
3,603,304	A *	9/1971	Maier	600/499
3,633,567	A *	1/1972	Sarnoff	600/499
3,760,795	A *	9/1973	Adelhed	
3,906,937	A *	9/1975	Aronson	600/493

FOREIGN PATENT DOCUMENTS

CA	2100854	1/1994
GB	740181	* 11/1955

OTHER PUBLICATIONS

Operating Instruction Manual, "Welch Allyn® DuraShock™ Integrated Aneroid Sphygmomanometer", pp. 1-7, © 2001.*
European Search Report for EP Application No. 06790195.9; mailed Oct. 30, 2009; 11 pages.

* cited by examiner

Primary Examiner — Charles A Marmor, II

(57) **ABSTRACT**

A blood pressure measuring apparatus includes an inflatable sleeve adapted to be wrapped about a limb of a patient. The sleeve includes an interior and at least one socket provided on an exterior surface of the sleeve, the socket being fluidly connected to the interior of the sleeve. A gage is directly attached to the sleeve socket through attachment of a mating engagement portion. A pneumatic bulb is also attached fluidly to the sleeve through a receiving port which is provided on at least one of the socket and the gage.

15 Claims, 5 Drawing Sheets

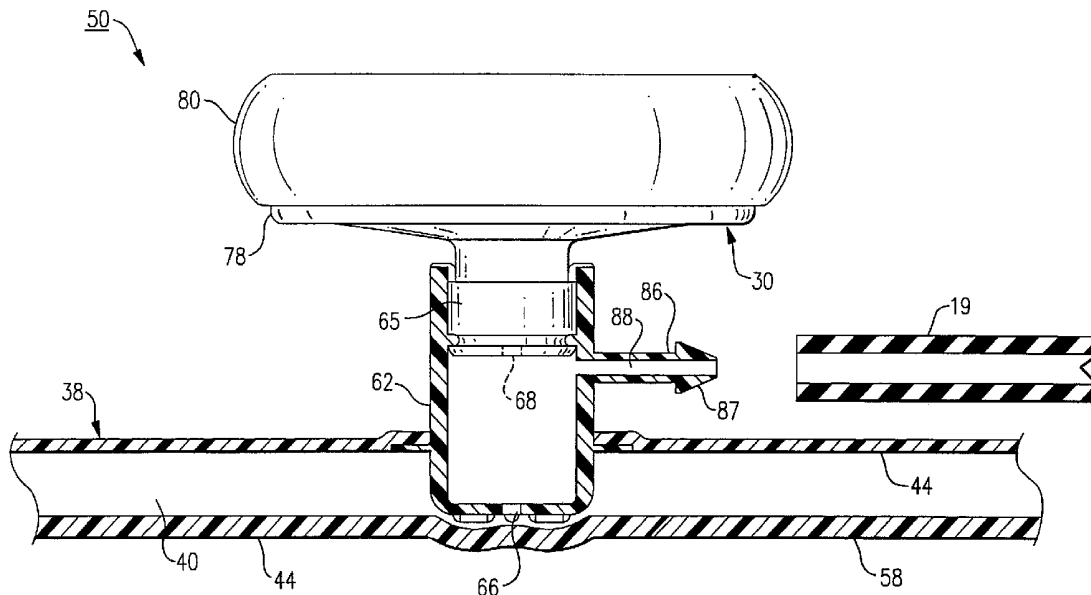

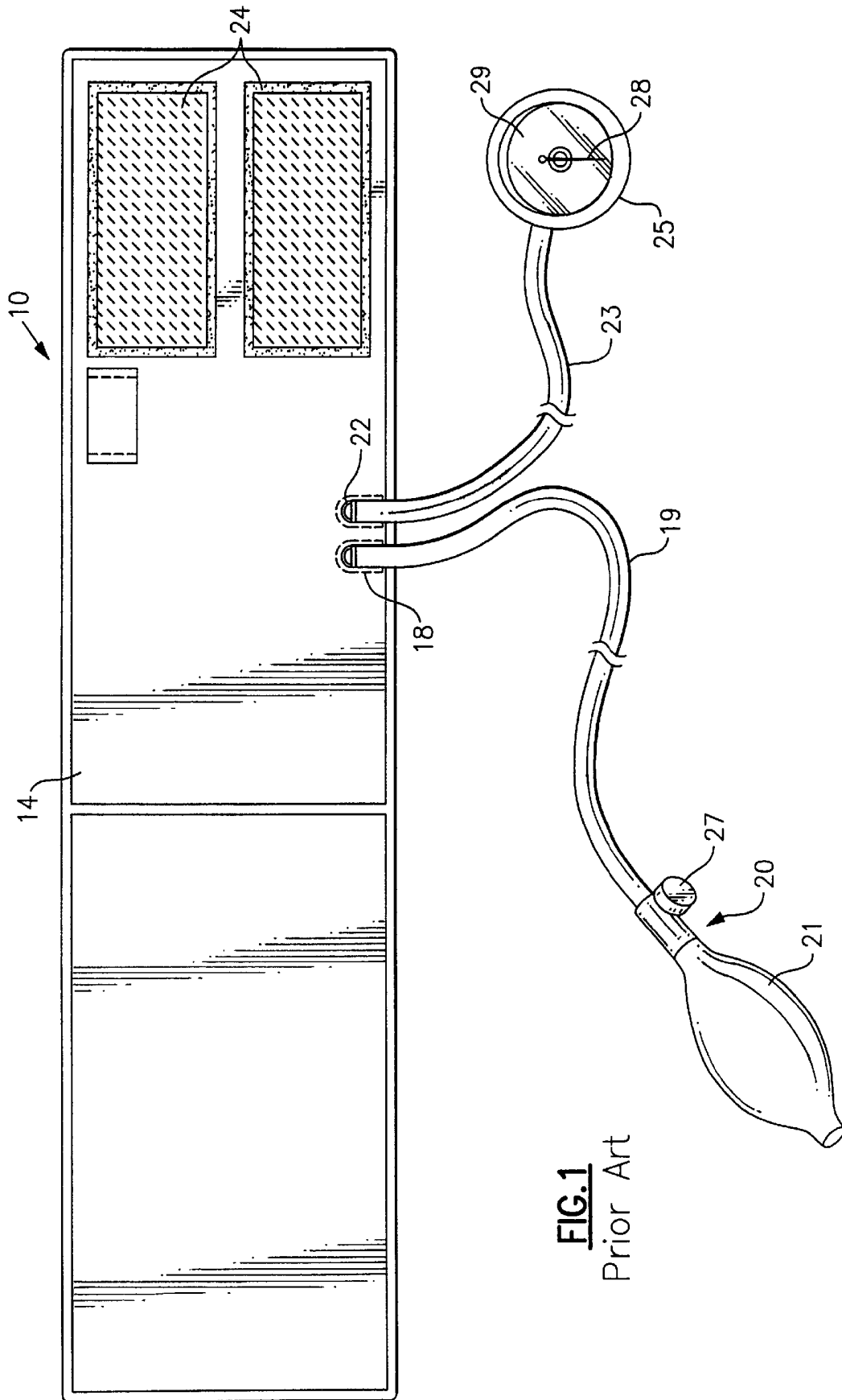
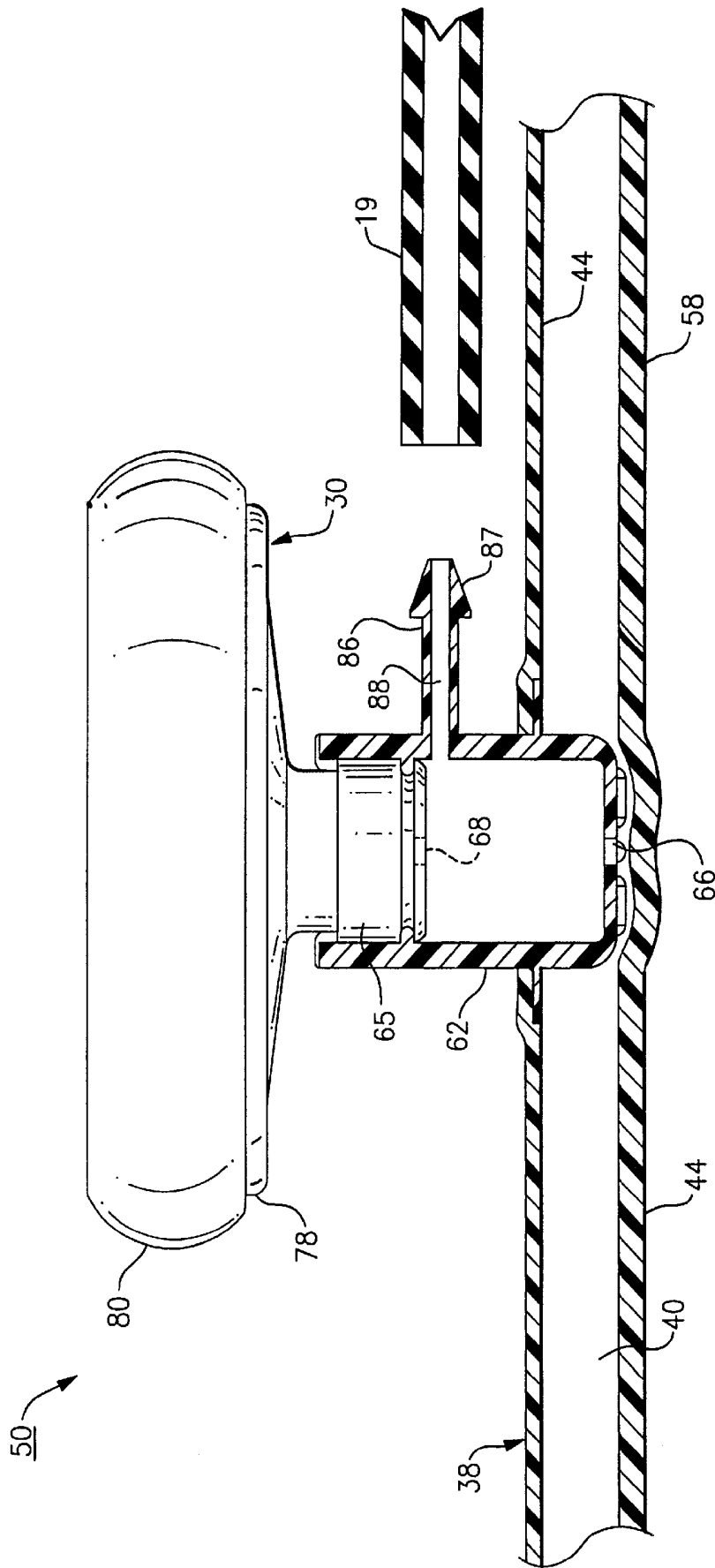

FIG. 1
Prior Art



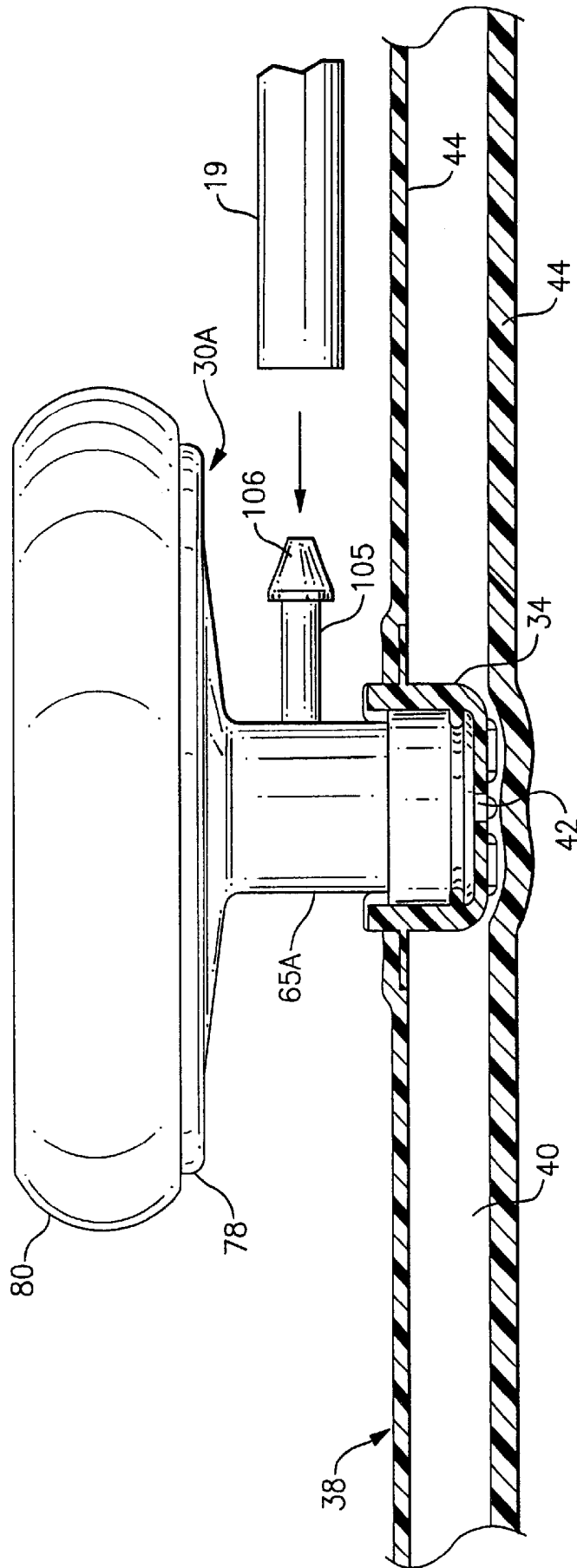

FIG. 4

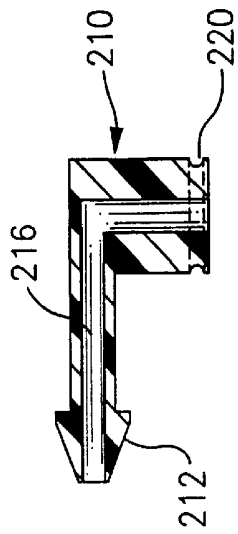

FIG. 6

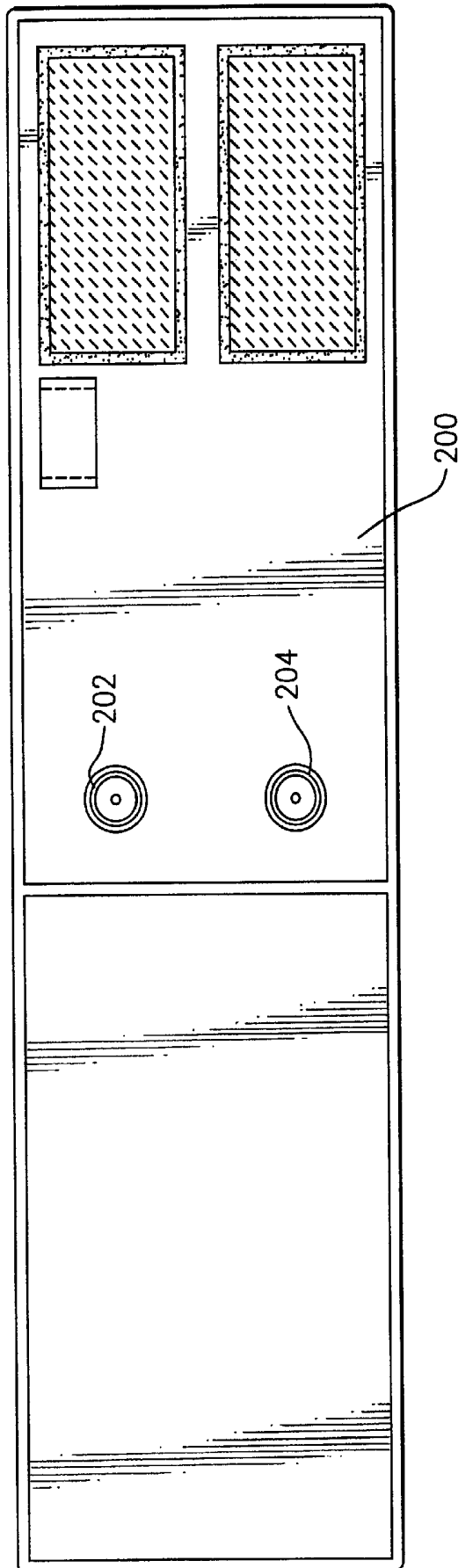

FIG. 5

BLOOD PRESSURE MEASURING APPARATUS

Matter enclosed in heavy brackets [] appears in the original patent but forms no part of this reissue specification; matter printed in italics indicates the additions made by reissue.

FIELD OF THE INVENTION

This invention is directed to the field of medical diagnostic instruments, and in particular to a preferred interconnection between a gage housing and an inflatable sleeve of a blood pressure measuring apparatus.

BACKGROUND OF THE INVENTION

Typical blood pressure measuring instruments include an inflatable sleeve which is wrapped about the limb (i.e., arm or leg) of a patient. A pneumatic bulb is tethered by a hose and is fully interconnected to the sleeve interior. A gage which includes a dial face having a set of indicia is separately interconnected also by means of a hose to the sleeve interior. The gage includes an interior movement mechanism which is responsive to changes in pressure within the sleeve interior. The pressure changes produce circumferential movement of an indicating member attached to the movement mechanism relative to the set of indicia on the dial face of the gage.

Both the gage and the pneumatic bulb are tethered individually to the sleeve which includes corresponding barbs or receiving ports which permit fluid communication with the interior of the sleeve.

More recently, Applicants have devised a blood pressure measuring apparatus, such as described in copending U.S. Ser. No. 09/669,474, the entire contents of which are incorporated by reference in which the gage is directly attached to a port or socket which is integrally provided in the inflatable sleeve. This form of attachment is advantageous because the apparatus is far more compact than previously known devices of this type. Furthermore, the attachment eliminates any need for hoses between the gage and the inflatable sleeve. Moreover, the gage can be rotatably attached to the socket/sleeve permitting both left and right limb attachment and also allowing both a care giver and the patient to easily read the dial face of the gage and perform a blood pressure measurement.

There is still a general need in the field, however, to further simplify the manufacture and design of a blood pressure measuring apparatus.

SUMMARY OF THE INVENTION

According to an embodiment of the invention, there is described a blood pressure measuring apparatus comprising an inflatable sleeve having at least one port and a pneumatic bulb tethered to said sleeve through a hose, one end of said hose being attached to said pneumatic bulb and a remaining end of said hose being attached to a port on said sleeve. The measuring apparatus further includes a gage having a dial face with readable indicia and a movement mechanism which is responsive to fluid pressure changes in said sleeve, said gage being directly attached to said at least one socket of said inflatable sleeve, the socket permitting one end of the gage to be directly connected to the sleeve without the use of a hose.

A port is provided to receive the hose end extending from the pneumatic bulb wherein this receiving port can be provided on at least one of the sleeve socket and the gage.

In either instance, and by providing the receiving port on either the socket or the gage which directly mounts to the inflatable sleeve, the design and manufacturability of a blood pressure measuring apparatus is greatly simplified in comparison to previously known apparatus of this type.

According to another embodiment of the invention, there is described a blood pressure measuring apparatus including an inflatable sleeve having at least one port sized for directly receiving a gage wherein the gage includes an engagement portion which is sealingly fitted into said at least one port. The gage further includes a receiving port for receiving fluid input from a pneumatic means, such as a depressible bulb which is attached thereto.

According to yet another embodiment of the invention, there is disclosed a blood pressure measuring apparatus including an inflatable sleeve containing a pair or sockets each sized for receiving the mating end of a gage. A receiving port is provided on at least one of the sockets or the gage to permit attachment of a depressible bulb or other pneumatic means used to inflate the sleeve.

BRIEF DESCRIPTION OF THE DRAWINGS

For a further understanding of the invention, reference will be made to the following Detailed Description which is to be read in connection with the accompanying drawings, wherein:

FIG. 1 is a top perspective view of a prior art blood pressure measuring apparatus;

FIG. 2 is a side elevational view, in section of a prior art blood pressure measuring apparatus;

FIG. 3 is a partial side elevational view of a blood pressure measuring apparatus according to a first embodiment of the invention;

FIG. 4 is a partial side elevational view of a blood pressure measuring apparatus according to a second embodiment of the invention;

FIG. 5 is a top elevational view of a sleeve of a blood pressure measuring apparatus made in accordance with a third embodiment of the invention, and

FIG. 6 is a sectioned view of a port adapter which can be attached to the sleeve of FIG. 5.

DETAILED DESCRIPTION

Referring to FIG. 1, there is shown a prior art blood pressure measuring device or apparatus 10. An inflatable sleeve 14 made from a fluid impermeable material includes a pair of ports 18, 22 which engage hoses 19, 23 interconnecting the interior of the inflatable sleeve with a pneumatic assembly 20 and a gage 25, respectively. The sleeve 14 is wrapped around a limb of a patient using a set of hook and loop fasteners 24 and is subsequently inflated by squeezing a depressible bulb 21 which supplies air through the tethered hose 19 to the interior of the sleeve. As air enters the interior of the sleeve, a movement mechanism (not shown in this Fig.) provided within the interior of the gage 25 causes a corresponding circumferential movement of an indicating member 28 relative to indicia provided on a dial face 29. Following sufficient inflation of the wrapped sleeve 14, the sleeve 14 is deflated using a bleed valve 27 of the pneumatic assembly 20 and a blood pressure measurement is taken using a stethoscope (not shown) which is applied over the brachial artery of the patient in conjunction with the readings taken from the tethered gage 25 in a manner which is conventionally known.

A second prior art blood pressure measuring device 32 is partially shown in FIG. 2. In this instance, and rather than

employing a hose in connection therewith, a mating end of a gage **30** is directly and sealingly engaged within a socket **34** that is provided in an inflatable sleeve **38**. In this embodiment, the inflatable sleeve **38** includes an interior **40**, the sleeve being made from a pair of sleeve portions **44**, which are RF welded or otherwise attached together. A specific type of sleeve which can be used for purposes of the present invention is described in U.S. Pat. No. 6,036,718, the entire contents of which are incorporated by reference, though it should be appreciated that other sleeve designs can be utilized. The socket **34** is defined through a slot provided in one of the sleeve portions **44** and includes a open-ended cylindrical cavity having a bottom opening **42** that fluidly interconnects the interior **40** of the sleeve **38** with the interior of an attached gage **30**.

The gage **30** illustrated in FIG. 2 is herein described in greater detail, and includes an upper portion **78** which supports a dial face **82** having a set of measurement indicia (not shown) and a lower engagement portion **65** which is received directly by the socket **34**. A peripheral bumper **80** is fitted about the upper portion **78** of the gage **30** to protect the contained movement mechanism from shock or impact loads. The gage **30** includes an interior sized for retaining the movement mechanism which includes a diaphragm **114** having a movable surface **116** that is responsive to pressure changes within the interior **40** of the sleeve **38**. This movement mechanism is herein described in greater detail with regard to the operation of the herein described apparatus.

In operation, the interior **40** of the sleeve **38** is inflated by squeezing a depressible bulb **21**, FIG. 1, which is interconnected to the sleeve **30** through a tethered interconnection to a port **18**, FIG. 1. Squeezing the depressible bulb **21**, FIG. 1, inflates the interior **40** of the sleeve **38** as air/fluid is pushed through the interconnecting hose **19**, FIG. 1, into the sleeve interior **40**. As the sleeve **38** is inflated, pressure changes are sensed by the movement mechanism within the gage housing **30** as follows.

Air entering the sleeve interior **40** is also caused to enter the gage **30** through the socket opening **42** and also through an opening **68** provided at the bottom of the gage. Entering air causes axial upward movement of the movable surface **116** of the diaphragm **114** which is imparted to the end of an axially displaceable shaft member **130** which is vertically supported therein. The shaft member **130** is also caused to rotate as well as translate due to constraints provided by a helically wound ribbon spring **134** made from beryllium copper or other similar spring material. The ribbon spring **134** is supported at one upper end to an intermediate portion of the shaft member **130** and at an opposite end to a fixed portion of the gage **30**.

Rotation of the shaft member **130** due to the flexion of the helically wound ribbon spring **134** causes corresponding circumferential movement of an attached indicating member **136** attached to an extending end of the shaft member. The indicating member **136** is disposed in relation to the indicia of the dial face **82**. Additional details regarding the herein described movement mechanism described herein are provided in U.S. Pat. Nos. 5,966,829 and 6,120,458, the entire contents of each being herein incorporated by reference, while further details relating to the socket and the direct interconnection of a gage to an inflatable sleeve are provided in previously incorporated U.S. Ser. No. 09/669,474.

Having supplied the preceding background and now referring to FIG. 3, there is shown a blood pressure measuring apparatus **50** made in accordance with a first embodiment of the invention. For purposes of the following discussion, similar parts are identified with the same reference numerals for the sake of convenience.

An inflatable sleeve **38** includes an interior **40**, the sleeve being made from a pair of sleeve portions **44**, which are interconnected together as previously described. A specific type of sleeve which can be used for these purposes is described in previously incorporated U.S. Pat. No. 6,036,718. As previously noted, however, it should be apparent that other bladderless and bladder-type sleeve designs can be utilized.

One of the sleeve portions **44** includes a socket **62** which is attached by welding or other means to a slot, the socket being fluidly interconnected to the interior **40** of the sleeve **38** through an opening **66**. The socket **62** extends above the plane of the exterior of a sleeve portion **44** and includes a laterally projecting receiving port **86** which is sized to receive a depending end of a hose **19** of a pneumatic assembly **20**, FIG. 1.

The laterally projecting receiving port **86** includes a through passage **88** which extends to the socket interior and includes a barb **87** onto which the hose can be attached.

The pneumatic assembly **20** includes a flexible depressible bulb **21**, FIG. 1, which is attached through the hose **19** and further includes bleed valve **27**, FIG. 1. Air which enters the socket **62** from the pneumatic assembly is communicated to the interior **40** of the sleeve **38** as well as the interior of the attached gage **30**.

The gage housing **30** according to this embodiment includes a movement mechanism (not shown in this Fig.) as described above such that air entering the socket **65** is directed into the sleeve interior **40** through opening **66** and into the interior of the gage **30** through opening **68**.

According to a second embodiment as shown in FIG. 4, a laterally projecting receiving port **106** can be similarly provided on the mating end **65A** of a similar gage **30A**, the receiving port being disposed a predetermined distance from the lower end of the gage to permit seating of the gage **30A** within the socket **34** of the inflatable sleeve **38**.

In operation, the apparatus functions similarly wherein the hose **19** of the pneumatic assembly **20**, FIG. 1, is attached to the barb **106** of the receiving port **105**. Squeezing the bulb **21**, FIG. 1, permits air to be directed into both the lower portion **65A** of the gage **30A** and the interior **40** of the sleeve **30** based on the attachment of the gage to the socket **34**.

Following inflation in either embodiment, the bleed valve **27**, FIG. 1, permits deflation of the inflatable sleeve **38** and a blood pressure measurement can be made using a stethoscope (not shown) which can be placed over the brachial artery (in the case in which the limb is an arm, not shown) done in a conventional manner.

Other embodiments utilizing the inventive concepts described herein are possible. For example and referring to FIG. 5, an inflatable sleeve **200** similar to that previously described can be provided with a pair of sockets **202**, **204**, each of the sockets being sized to directly accept the mating or engagement end **65**, FIG. 3, of a gage housing **30**, FIG. 3, as previously described. Each of the sockets **202**, **204** can, as in this instance, be similarly constructed with the gage **30**, FIG. 3 including a laterally extending receiving port **86** such as previously described. Alternately, either or both of the sockets **202**, **204** could include a laterally projecting receiving port **105**, such as previously shown in FIG. 4.

Providing a pair of sockets **202**, **206** on the inflatable sleeve **200** provides significant versatility in the location of a gage **30**, **30A** which is directly mounted thereupon.

According to yet another alternate variation, a port adapter **210** is illustrated in FIG. 6 which can also be used in conjunction with the sleeve **200**, the adapter **210** being fitted into one of the sockets **202**, **204** to accept, for example, a hose **19** such as shown in FIG. 1 therein and a gage **25** in the other of the sockets. The port adapter **210** includes a barb **212** which

matingly receives the hose 19, FIG. 1, and a channel 216 defining a fluid path to the interior of the sleeve 200. The adapter 210 includes a plug-like end 220 which permits fluid-seal attachment to one of the sockets 202, 204.

PARTS LIST FOR FIGS. 1-6

10 blood pressure measuring apparatus
 14 inflatable sleeve
 18 port
 19 hose
 20 pneumatic assembly
 21 depressible bulb
 22 port
 23 hose
 24 hook and loop fasteners
 25 gage
 27 bleed valve
 28 indicating member
 29 dial face
 30 gage
 30A gage
 32 blood pressure measuring apparatus
 34 socket
 38 sleeve
 40 interior
 42 bottom opening
 44 sleeve portions
 50 blood pressure measuring apparatus
 62 socket
 65 engagement portion
 65A engagement portion
 66 opening
 68 opening
 78 upper portion
 80 peripheral bumper
 82 dial face
 86 laterally projecting receiving port
 87 barb
 88 through passage
 105 receiving port
 106 barb
 114 diaphragm
 116 movable surface
 130 axially displaceable shaft member
 134 ribbon spring
 200 sleeve
 202 socket
 204 socket
 210 port adapter
 212 barb
 216 channel
 220 plug-like end

While the present invention has been described with reference to the preferred embodiments, it should be readily apparent that modifications and variations are possible without departing from the intended scope of the invention as defined by the claims.

We claim:

1. A blood pressure measuring apparatus comprising:
 an inflatable sleeve adapted to be wrapped about a limb of a patient, said sleeve including an interior and at least one socket provided in an exterior surface of said sleeve, said at least one socket including an opening that is fluidly and directly connected to the interior of said inflatable sleeve;
 a gage housing having an integral mating end releasably fitted directly into said at least one socket provided on the exterior surface of said sleeve;

a pneumatic means for inflating said sleeve; and
 means for attaching said pneumatic means to said sleeve, said attaching means including a receiving means provided on one of said at least one socket [and], said mating end of said gage housing and an adapter releasably fitted into said at least one socket.

2. An apparatus as recited in claim 1, wherein said receiving means is provided on said socket.

3. An apparatus as recited in claim 2, wherein an axial portion of said socket extends above the exterior surface of said sleeve.

4. An apparatus as recited in claim 1, wherein said receiving means includes a port provided on the mating end of said gage housing.

5. An apparatus as recited in claim 4, wherein said port is provided a predetermined distance from an end of said mating end of said gage housing along a length thereof.

6. An apparatus as recited in claim 1, wherein said sleeve includes at least two sockets.

7. An apparatus as recited in claim 1, wherein said receiving means includes a port sized for receiving a hose from said pneumatic means.

8. An apparatus as recited in claim 1, wherein said gage housing includes an opening at a distal end of said mating end, said opening extending to the interior of said socket.

9. An apparatus as recited in claim 8, wherein said gage housing contains an indicating mechanism that is responsive to pressure changes from said sleeve interior.

10. A blood pressure measuring system, said system comprising:

a unitary flexible sleeve member which is adapted to be wrapped around the limb of a patient, said sleeve member including an exterior surface and an inflatable interior;

a gage housing having a mating end;

a hose adapter; and

at least one socket provided within said exterior surface, said at least one socket including an opening that is fluidly and directly connected to the inflatable interior of said sleeve member, said at least one socket being adapted for interchangeably receiving at least one of said gage housing and said hose adapter, said gage housing and said hose adapter being releasably and directly connected in interchangeable fashion to said at least one socket without intermediate hoses therebetween, and in which each of said gage housing and said hose adapter are mechanically supported solely by said at least one socket when connected to said sleeve member.

11. A system as recited in claim 10, wherein said at least one socket is secured to the exterior surface of said unitary flexible sleeve member.

12. A system as recited in claim 11, wherein said at least one socket is welded to the exterior surface of said unitary flexible sleeve member.

13. A system as recited in claim 10, wherein said sleeve member includes at least a pair of sockets.

14. A system as recited in claim 10, wherein said at least one socket includes a substantially cylindrical body having a cavity, said body being substantially recessed within the interior of said unitary flexible sleeve member and including an upper lip that is substantially coplanar with the exterior surface.

15. A system as recited in claim 10, wherein said at least one socket is adapted to permit said at least one of said gage housing and said hose adapter to be rotatably supported thereupon.

专利名称(译)	血压测量装置		
公开(公告)号	USR42754	公开(公告)日	2011-09-27
申请号	US11/205302	申请日	2005-08-16
[标]申请(专利权)人(译)	伟伦公司		
申请(专利权)人(译)	伟伦, INC.		
当前申请(专利权)人(译)	伟伦, INC.		
[标]发明人	LIA RAYMOND A VIVENZIO ROBERT L DANNA DOMINICK DROMMS RAYMOND P STEARNS SCOTT S BAXTER JAMES M		
发明人	LIA, RAYMOND A. VIVENZIO, ROBERT L. DANNA, DOMINICK DROMMS, RAYMOND P. STEARNS, SCOTT S. BAXTER, JAMES M.		
IPC分类号	A61B5/00 A61B5/022		
CPC分类号	A61B5/02141 A61B5/02233		
外部链接	Espacenet USPTO		

摘要(译)

血压测量装置包括适于缠绕在患者肢体周围的可充气套管。套筒包括内部和设置在套筒的外表面上的至少一个插座，插座流体连接到套筒的内部。通过连接配合接合部分将测厚仪直接连接到套筒插座。气动灯泡也通过接收端口流体地连接到套管，该接收端口设置在插座和测量仪中的至少一个上。

