



US009913982B2

(12) **United States Patent**
Bolea et al.

(10) **Patent No.:** **US 9,913,982 B2**
(45) **Date of Patent:** **Mar. 13, 2018**

(54) **OBSTRUCTIVE SLEEP APNEA TREATMENT DEVICES, SYSTEMS AND METHODS**

(75) Inventors: **Stephen L. Bolea**, Watertown, MN (US); **Thomas B. Hoegh**, Edina, MN (US); **Brian D. Kuhnley**, Maple Grove, MN (US); **Dale G. Sulmann**, Elk River, MN (US); **Bruce J. Persson**, Shoreview, MN (US); **John P. Beck**, Prior Lake, MN (US); **Sidney F. Hauschild**, Cottage Grove, MN (US); **Wondimeneh Tesfayesus**, St. Paul, MN (US); **Jason J. Skubitz**, Arden Hills, MN (US); **Mark R. Bosshard**, Shoreview, MN (US); **Daniel A. Parrish**, Bloomington, MN (US); **Robert E. Atkinson**, White Bear Lake, MN (US)

(52) **U.S. Cl.**
CPC *A61N 1/3601* (2013.01); *A61N 1/0556* (2013.01); *A61N 1/3611* (2013.01); (Continued)

(58) **Field of Classification Search**
CPC ... *A61N 1/00*; *A61N 1/08*; *A61N 1/34*; *A61N 1/0551*; *A61N 1/0553*; *A61N 1/0556*; (Continued)

(56) **References Cited**

U.S. PATENT DOCUMENTS

758,030 A 4/1904 Carence
1,520,930 A 12/1924 Calhoun
(Continued)

FOREIGN PATENT DOCUMENTS

EP 0 892 926 B1 6/2002
EP 0 900 102 B1 7/2004
(Continued)

OTHER PUBLICATIONS

The Paquereau et al. Article—An English language Abstract of this document is provided herewith.

(Continued)

Primary Examiner — Christopher D Koharski

Assistant Examiner — Elizabeith K So

(74) *Attorney, Agent, or Firm* — Foley & Lardner LLP

(73) Assignee: **Cyberonics, Inc.**, Houston, TX (US)

(*) Notice: Subject to any disclaimer, the term of this patent is extended or adjusted under 35 U.S.C. 154(b) by 134 days.

(21) Appl. No.: **13/106,460**

(22) Filed: **May 12, 2011**

(65) **Prior Publication Data**

US 2012/0192874 A1 Aug. 2, 2012

Related U.S. Application Data

(60) Provisional application No. 62/437,573, filed on Jan. 28, 2011.

(51) **Int. Cl.**

A61N 1/00 (2006.01)
A61N 1/36 (2006.01)
A61N 1/05 (2006.01)
A61N 1/372 (2006.01)
A61B 5/08 (2006.01)
A61B 5/00 (2006.01)

(57) **ABSTRACT**

Devices, systems and methods of neurostimulation for treating obstructive sleep apnea. The system is adapted to send an electrical signal from an implanted neurostimulator through a stimulation lead to a patient's nerve at an appropriate phase of the respiratory cycle based on input from a respiration sensing lead. External components are adapted for wireless communication with the neurostimulator. The neurostimulator is adapted to deliver therapeutic stimulation based on inputs.

31 Claims, 29 Drawing Sheets

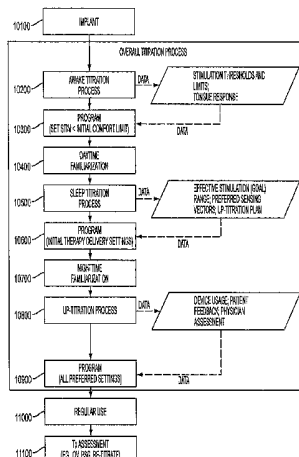

- (52) **U.S. Cl.**
 CPC *A61N 1/3615* (2013.01); *A61N 1/36139*
 (2013.01); *A61N 1/37235* (2013.01); *A61B*
5/0809 (2013.01); *A61B 5/0826* (2013.01);
A61B 5/4818 (2013.01); *A61N 1/36132*
 (2013.01)

- (58) **Field of Classification Search**
 CPC *A61N 1/18*; *A61N 1/3601*; *A61N 1/3605*;
A61N 1/36053; *A61N 1/36057*; *A61N*
1/3606; *A61N 1/36078*; *A61N 1/3611*;
A61N 1/36128; *A61N 1/36132*; *A61N*
1/36135; *A61N 1/36139*; *A61N 1/36142*;
A61N 1/36146; *A61N 1/3615*; *A61N*
1/36153; *A61N 1/36157*; *A61N 1/3616*;
A61N 1/36167; *A61N 1/36171*; *A61N*
1/36175; *A61N 1/36178*; *A61N 1/36182*;
A61N 1/36185; *A61N 1/36189*; *A61N*
1/36192; *A61N 1/36196*

See application file for complete search history.

(56) **References Cited**

U.S. PATENT DOCUMENTS

1,701,277 A	2/1929	Shindel	5,344,438 A	9/1994	Testerman et al.
1,914,418 A	6/1933	Goyena	5,388,578 A	2/1995	Yomtov et al.
2,046,664 A	7/1936	Weaver	5,392,773 A	2/1995	Bertrand
2,151,227 A	3/1939	Pawelek	5,417,205 A	5/1995	Wang
2,237,954 A	4/1941	Wilsom	5,425,359 A	6/1995	Liou
2,243,360 A	5/1941	Slatis	5,458,629 A	10/1995	Baudino et al.
2,274,886 A	3/1942	Carroll	5,483,969 A	1/1996	Testerman et al.
2,526,586 A	10/1950	Shuff	5,485,836 A	1/1996	Lincoln
2,693,799 A	11/1954	Herman	5,485,851 A	1/1996	Erickson
2,777,442 A	1/1957	Zelano	5,487,756 A	1/1996	Kallesoe et al.
2,928,388 A	3/1960	Jaroslav	5,511,543 A	4/1996	Shirley
3,457,917 A	7/1969	Mercurio	5,522,382 A	6/1996	Sullivan et al.
3,513,839 A	5/1970	Vacante	5,522,862 A	6/1996	Testerman et al.
3,680,555 A	8/1972	Warncke	5,531,778 A	7/1996	Maschino et al.
3,722,509 A	3/1973	Nebel	5,540,732 A	7/1996	Testerman
3,774,618 A	11/1973	Avery	5,540,733 A	7/1996	Testerman et al.
3,865,106 A	2/1975	Palush	5,540,734 A	7/1996	Zabara
3,884,223 A	5/1975	Keindl	5,546,938 A	8/1996	McKenzie
3,906,936 A	9/1975	Habal	5,549,655 A	8/1996	Erickson
4,220,150 A	9/1980	King	5,568,808 A	10/1996	Rimkus
4,221,217 A	9/1980	Amezcuca	5,591,216 A	1/1997	Testerman et al.
4,267,831 A	5/1981	Aguilar	5,630,411 A	5/1997	Holscher
4,374,527 A	2/1983	Iversen	5,682,881 A	11/1997	Winthrop et al.
4,506,666 A	3/1985	Durkan	5,697,105 A	12/1997	White
4,567,892 A	2/1986	Plicchi et al.	5,697,363 A	12/1997	Hart
4,573,481 A	3/1986	Bullara	5,730,122 A	3/1998	Lurie
4,777,963 A	10/1988	McKenna	5,740,798 A	4/1998	McKinney
4,830,008 A	5/1989	Meer	5,752,511 A	5/1998	Simmons et al.
4,899,750 A	2/1990	Eckwall	5,787,884 A	8/1998	Tovey
4,915,105 A	4/1990	Lee	5,826,579 A	10/1998	Remmers et al.
4,919,136 A	4/1990	Alt	5,848,589 A	12/1998	Welnetz
4,940,065 A	7/1990	Tanagho et al.	5,855,552 A	1/1999	Houser et al.
4,960,133 A	10/1990	Hewson	5,890,491 A	4/1999	Rimkus
4,996,983 A	3/1991	AmRhein	5,895,360 A	4/1999	Christopherson et al.
5,016,808 A	5/1991	Heil, Jr. et al.	5,919,220 A	7/1999	Stieglitz et al.
5,105,826 A	4/1992	Smits et al.	5,922,014 A	7/1999	Warman et al.
5,121,754 A	6/1992	Mullett	5,938,596 A	8/1999	Woloszko et al.
5,133,354 A	7/1992	Kallock	5,944,680 A	8/1999	Christopherson et al.
5,146,918 A	9/1992	Kallock et al.	5,947,119 A	9/1999	Reznick
5,158,080 A	10/1992	Kallock	6,010,459 A	1/2000	Silkoff et al.
5,174,287 A	12/1992	Kallock et al.	6,015,389 A	1/2000	Brown
5,178,156 A	1/1993	Takishima et al.	6,021,352 A	2/2000	Christopherson et al.
5,190,053 A	3/1993	Meer	6,021,354 A	2/2000	Warman et al.
5,211,173 A	5/1993	Kallock et al.	6,029,667 A	2/2000	Lurie
5,215,082 A	6/1993	Kallock et al.	6,041,780 A	3/2000	Richard
5,277,193 A	1/1994	Takishima et al.	6,066,165 A	5/2000	Racz
5,281,219 A	1/1994	Kallock et al.	6,098,624 A	8/2000	Utamaru
5,282,468 A	2/1994	Klepinski	6,109,262 A	8/2000	Tovey
5,300,094 A	4/1994	Kallock et al.	6,119,690 A	9/2000	Pentaleo
5,324,321 A	6/1994	Pohndorf et al.	6,126,611 A	10/2000	Bourgeois et al.
5,335,657 A	8/1994	Terry, Jr. et al.	6,132,384 A	10/2000	Christopherson et al.
			6,198,970 B1	3/2001	Freed et al.
			6,201,994 B1	3/2001	Warman et al.
			6,205,360 B1*	3/2001	Carter et al. 607/57
			6,217,527 B1	4/2001	Selmon et al.
			6,221,049 B1	4/2001	Selmon et al.
			6,231,546 B1	5/2001	Milo et al.
			6,240,316 B1	5/2001	Richmond et al.
			6,244,267 B1	6/2001	Eifrig
			6,251,126 B1	6/2001	Ottenhoff et al.
			6,269,269 B1	7/2001	Ottenhoff et al.
			6,292,703 B1	9/2001	Meier et al.
			6,345,202 B2	2/2002	Richmond et al.
			6,366,815 B1	4/2002	Haugland et al.
			6,460,539 B1	10/2002	Japuntich et al.
			6,484,725 B1	11/2002	Chi
			6,511,458 B2	1/2003	Milo et al.
			6,514,217 B1	2/2003	Selmon et al.
			6,542,776 B1	4/2003	Gordon et al.
			6,561,188 B1	5/2003	Ellis
			6,587,725 B1	7/2003	Durand et al.
			6,600,956 B2	7/2003	Maschino et al.
			6,606,521 B2	8/2003	Paspa et al.
			6,626,179 B1	9/2003	Pedley
			6,636,767 B1	10/2003	Knudson et al.
			6,641,542 B2	11/2003	Cho et al.
			6,647,289 B2	11/2003	Prutchi
			6,651,652 B1	11/2003	Ward
			6,718,982 B2	4/2004	Smith et al.

(56)

References Cited

U.S. PATENT DOCUMENTS

6,719,725 B2	4/2004	Milo et al.	7,734,348 B2	6/2010	Zhang et al.
6,721,603 B2	4/2004	Zabara et al.	7,738,952 B2	6/2010	Yun et al.
6,772,015 B2	8/2004	Dahl et al.	7,747,323 B2	6/2010	Libbus et al.
6,776,162 B2	8/2004	Wood	7,751,880 B1	7/2010	Cholette
6,799,575 B1	10/2004	Carter	7,751,885 B2	7/2010	Bardy et al.
6,819,958 B2	11/2004	Weiner et al.	7,758,384 B2	7/2010	Alexander et al.
6,829,503 B2	12/2004	Alt	7,765,000 B2	7/2010	Zhang et al.
6,829,508 B2	12/2004	Schulman et al.	7,769,461 B2	8/2010	Whitehurst et al.
RE38,705 E	2/2005	Hill et al.	7,783,353 B2	8/2010	Libbus et al.
6,876,885 B2	4/2005	Swoyer et al.	7,785,262 B2	8/2010	Melker et al.
6,881,192 B1	4/2005	Park	7,787,959 B1	8/2010	Morgan
6,883,518 B2	4/2005	Mittelstadt et al.	7,792,590 B1	9/2010	Pianca et al.
6,890,306 B2	5/2005	Poezevera	7,797,050 B2	9/2010	Libbus et al.
6,904,320 B2	7/2005	Park et al.	7,797,057 B2	9/2010	Harris
6,907,295 B2	7/2005	Gross et al.	7,797,058 B2	9/2010	Mrva et al.
6,928,324 B2	8/2005	Park et al.	7,805,195 B2	9/2010	Zealear
6,978,171 B2	12/2005	Goetz et al.	7,809,442 B2	10/2010	Bolea et al.
6,997,177 B2	2/2006	Wood	7,813,797 B2	10/2010	Bardy et al.
7,027,869 B2	4/2006	Danek et al.	7,813,802 B2	10/2010	Tcheng et al.
7,054,692 B1	5/2006	Whitehurst et al.	7,813,809 B2	10/2010	Strother et al.
7,065,410 B2	6/2006	Bardy et al.	7,818,063 B2	10/2010	Wallace et al.
7,082,331 B1	7/2006	Park et al.	7,822,486 B2	10/2010	Foster et al.
7,087,053 B2	8/2006	Vanney	8,249,723 B2	8/2012	McCreery
7,089,932 B2	8/2006	Dodds	8,311,645 B2	11/2012	Bolea et al.
7,094,206 B2	8/2006	Hoffman	8,386,046 B2	2/2013	Tesfayesus et al.
7,117,036 B2	10/2006	Florio	8,428,727 B2	4/2013	Bolea et al.
7,128,717 B1	10/2006	Thatch et al.	8,498,712 B2	7/2013	Bolea et al.
7,142,919 B2	11/2006	Hine et al.	8,626,304 B2	1/2014	Bolea et al.
7,149,573 B2	12/2006	Wang	8,639,354 B2	1/2014	Bolea et al.
7,152,604 B2	12/2006	Hickle et al.	8,718,783 B2	5/2014	Bolea et al.
7,155,278 B2	12/2006	King et al.	8,744,584 B2	6/2014	Camps et al.
7,156,098 B2	1/2007	Dolezal et al.	8,855,771 B2	10/2014	Tesfayesus et al.
7,160,252 B2	1/2007	Cho	2001/0010010 A1	7/2001	Richmond et al.
7,160,255 B2	1/2007	Saadat	2001/0031929 A1	10/2001	O'Toole
7,178,524 B2	2/2007	Noble	2002/0010495 A1	1/2002	Freed et al.
7,200,440 B2	4/2007	Kim et al.	2002/0049479 A1	4/2002	Pitts
7,225,034 B2	5/2007	Ries et al.	2002/0092527 A1	7/2002	Wood
7,239,918 B2	7/2007	Strother et al.	2002/0128700 A1	9/2002	Cross
7,239,920 B1*	7/2007	Thacker et al. 607/46	2002/0165462 A1	11/2002	Westbrook et al.
7,242,987 B2	7/2007	Holleman et al.	2002/0166556 A1	11/2002	Jacob
7,277,749 B2	10/2007	Gordon et al.	2002/0195108 A1	12/2002	Mittelstadt et al.
7,283,867 B2	10/2007	Strother et al.	2002/0195109 A1	12/2002	Mittelstadt et al.
7,302,951 B2	12/2007	Mittelstadt et al.	2003/0034031 A1	2/2003	Lev et al.
7,313,442 B2	12/2007	Velasco et al.	2003/0078643 A1	4/2003	Schulman et al.
7,346,398 B2	3/2008	Gross et al.	2003/0083696 A1	5/2003	Avital
7,366,572 B2	4/2008	Heruth et al.	2003/0093128 A1	5/2003	Freed et al.
7,396,333 B2	7/2008	Stahmann et al.	2003/0106555 A1	6/2003	Tovey
7,438,686 B2	10/2008	Cho et al.	2003/0106556 A1	6/2003	Alperovich et al.
7,463,928 B2	12/2008	Lee et al.	2003/0114895 A1	6/2003	Gordon et al.
7,473,227 B2	1/2009	Hsu et al.	2003/0114905 A1	6/2003	Kuzma
7,515,968 B2	4/2009	Metzler et al.	2003/0153953 A1	8/2003	Park et al.
7,524,292 B2	4/2009	Cho et al.	2003/0167018 A1	9/2003	Wyckoff
7,561,922 B2	7/2009	Cohen et al.	2003/0195571 A1	10/2003	Burnes et al.
7,591,265 B2	9/2009	Lee et al.	2003/0209145 A1	11/2003	Soper
7,596,413 B2	9/2009	Libbus et al.	2003/0216789 A1	11/2003	Deem et al.
7,596,414 B2	9/2009	Whitehurst et al.	2004/0015204 A1	1/2004	Whitehurst et al.
7,627,375 B2	12/2009	Bardy et al.	2004/0020489 A1	2/2004	Gillispie et al.
7,630,771 B2	12/2009	Cauler	2004/0049241 A1	3/2004	Campos
7,634,315 B2	12/2009	Cholette	2004/0055603 A1	3/2004	Bruce
7,636,602 B2	12/2009	Baru Fassio et al.	2004/0073272 A1	4/2004	Knudson et al.
7,657,311 B2	2/2010	Bardy et al.	2004/0089303 A1	5/2004	Chien
7,660,632 B2	2/2010	Kirby et al.	2004/0111139 A1	6/2004	McCreery
7,662,105 B2	2/2010	Hatlestad	2004/0116819 A1	6/2004	Alt
7,672,728 B2	3/2010	Libbus et al.	2004/0116978 A1*	6/2004	Bradley 607/48
7,672,729 B2	3/2010	Koh et al.	2004/0138581 A1	7/2004	Frei et al.
7,680,537 B2	3/2010	Stahmann et al.	2004/0153127 A1	8/2004	Gordon et al.
7,680,538 B2	3/2010	Durand et al.	2004/0162499 A1	8/2004	Nagai et al.
7,684,869 B2	3/2010	Bradley et al.	2004/0194784 A1	10/2004	Bertrand
7,697,984 B2	4/2010	Hill et al.	2004/0215288 A1	10/2004	Lee et al.
7,697,990 B2	4/2010	Ujhazy et al.	2004/0230278 A1	11/2004	Dahl et al.
7,717,848 B2	5/2010	Heruth et al.	2004/0233058 A1	11/2004	Dodds
7,720,534 B2	5/2010	Bardy et al.	2004/0260310 A1	12/2004	Harris
7,725,195 B2	5/2010	Lima et al.	2004/0261791 A1	12/2004	Horian
7,725,198 B2	5/2010	Cross, Jr. et al.	2005/0004610 A1	1/2005	Kim et al.
7,734,340 B2	6/2010	De Ridder	2005/0010265 A1	1/2005	Fassio et al.
			2005/0038490 A1	2/2005	Gross et al.
			2005/0039757 A1	2/2005	Wood
			2005/0043644 A1	2/2005	Stahmann et al.
			2005/0043772 A1	2/2005	Stahmann et al.

(56)

References Cited

U.S. PATENT DOCUMENTS

2005/0076908 A1 4/2005 Lee et al.
 2005/0085865 A1 4/2005 Tehrani
 2005/0085866 A1 4/2005 Tehrani
 2005/0085868 A1 4/2005 Tehrani et al.
 2005/0085869 A1 4/2005 Tehrani et al.
 2005/0085874 A1 4/2005 Davis et al.
 2005/0098176 A1 5/2005 Hoffrichter
 2005/0101833 A1 5/2005 Hsu et al.
 2005/0119711 A1 6/2005 Cho et al.
 2005/0139216 A1 6/2005 Mittelstadt et al.
 2005/0165457 A1 7/2005 Benser et al.
 2005/0209513 A1 9/2005 Heruth et al.
 2005/0209643 A1 9/2005 Heruth et al.
 2005/0234523 A1 10/2005 Levin et al.
 2005/0235992 A1 10/2005 Djupesland
 2005/0240241 A1 10/2005 Yun et al.
 2005/0251216 A1 11/2005 Hill et al.
 2005/0261747 A1 11/2005 Schuler et al.
 2005/0267380 A1 12/2005 Poezevara
 2005/0267547 A1 12/2005 Knudson et al.
 2005/0277844 A1 12/2005 Strother et al.
 2005/0277999 A1 12/2005 Strother et al.
 2005/0278000 A1 12/2005 Strother et al.
 2006/0004429 A1 1/2006 Mrva et al.
 2006/0005842 A1 1/2006 Rashad et al.
 2006/0025828 A1 2/2006 Armstrong et al.
 2006/0030919 A1 2/2006 Mrva et al.
 2006/0032497 A1 2/2006 Doshi
 2006/0041295 A1 2/2006 Osypka
 2006/0052836 A1 3/2006 Kim et al.
 2006/0058588 A1 3/2006 Zdeblick
 2006/0058852 A1 3/2006 Koh et al.
 2006/0064029 A1 3/2006 Arad
 2006/0064138 A1 3/2006 Velasco et al.
 2006/0079802 A1 4/2006 Jensen et al.
 2006/0095088 A1 5/2006 De Ridder
 2006/0111755 A1 5/2006 Stone et al.
 2006/0116739 A1 6/2006 Betser et al.
 2006/0129189 A1 6/2006 George et al.
 2006/0135886 A1 6/2006 Lippert et al.
 2006/0136024 A1 6/2006 Cohen et al.
 2006/0142815 A1 6/2006 Tehrani et al.
 2006/0144398 A1 7/2006 Doshi et al.
 2006/0149334 A1 7/2006 Tehrani et al.
 2006/0149345 A1 7/2006 Boggs et al.
 2006/0150978 A1 7/2006 Doshi et al.
 2006/0150979 A1 7/2006 Doshi et al.
 2006/0150980 A1 7/2006 Kim
 2006/0167497 A1 7/2006 Armstrong et al.
 2006/0184204 A1 8/2006 He
 2006/0195170 A1 8/2006 Cohen et al.
 2006/0211951 A1 9/2006 Milajasevic et al.
 2006/0224209 A1 10/2006 Meyer
 2006/0224211 A1 10/2006 Durand
 2006/0241506 A1 10/2006 Melker et al.
 2006/0241708 A1 10/2006 Boute
 2006/0247729 A1 11/2006 Tehrani et al.
 2006/0259079 A1 11/2006 King
 2006/0264777 A1 11/2006 Drew
 2006/0266369 A1 11/2006 Atkinson et al.
 2006/0271118 A1 11/2006 Libbus et al.
 2006/0271137 A1 11/2006 Stanton-Hicks
 2006/0282127 A1 12/2006 Zelear
 2006/0293720 A1 12/2006 DiLorenzo
 2006/0293723 A1 12/2006 Whitehurst et al.
 2007/0021785 A1 1/2007 Inman et al.
 2007/0027482 A1 2/2007 Parnis et al.
 2007/0038265 A1 2/2007 Tcheng et al.
 2007/0043411 A1 2/2007 Foster et al.
 2007/0095347 A1 5/2007 Lampotang et al.
 2007/0125379 A1 7/2007 Pierro et al.
 2007/0175478 A1 8/2007 Brunst
 2007/0227542 A1 10/2007 Kashmakov et al.
 2007/0239243 A1 10/2007 Moffitt et al.
 2007/0277832 A1 12/2007 Doshi et al.

2007/0282410 A1 12/2007 Cross et al.
 2007/0283692 A1 12/2007 Tetsuka et al.
 2007/0283962 A1 12/2007 Doshi et al.
 2007/0295338 A1 12/2007 Loomas et al.
 2008/0023007 A1 1/2008 Dolezal et al.
 2008/0027480 A1 1/2008 van der Burg et al.
 2008/0027502 A1 1/2008 Ransom
 2008/0041373 A1 2/2008 Doshi et al.
 2008/0099029 A1 5/2008 Lamberg
 2008/0103407 A1 5/2008 Bolea et al.
 2008/0103545 A1 5/2008 Bolea et al.
 2008/0163875 A1 7/2008 Aarestad et al.
 2008/0183254 A1 7/2008 Bly et al.
 2009/0044814 A1 2/2009 Iancea et al.
 2009/0270707 A1 10/2009 Alfoqaha et al.
 2009/0276024 A1 11/2009 Bonde et al.
 2009/0308395 A1 12/2009 Lee et al.
 2009/0318986 A1 12/2009 Alo et al.
 2009/0326408 A1 12/2009 Moon et al.
 2010/0016749 A1 1/2010 Atsma et al.
 2010/0036285 A1 2/2010 Govari et al.
 2010/0047376 A1 2/2010 Imbeau et al.
 2010/0076536 A1 3/2010 Merz et al.
 2010/0094379 A1 4/2010 Meadows et al.
 2010/0100150 A1 4/2010 Kirby et al.
 2010/0125310 A1 5/2010 Wilson et al.
 2010/0131029 A1 5/2010 Durand et al.
 2010/0137931 A1 6/2010 Hopper et al.
 2010/0137949 A1 6/2010 Mazgalev et al.
 2010/0137956 A1 6/2010 Osypka et al.
 2010/0152553 A1 6/2010 Ujhazy et al.
 2010/0174341 A1 7/2010 Bolea et al.
 2010/0228133 A1 9/2010 Averina et al.
 2010/0228317 A1 9/2010 Libbus et al.
 2010/0241207 A1 9/2010 Bluger
 2010/0257729 A1 10/2010 Alexander et al.
 2010/0262209 A1 10/2010 King et al.
 2011/0071591 A1 3/2011 Bolea et al.
 2011/0093032 A1 4/2011 Boggs et al.
 2012/0017920 A1 1/2012 Sanders
 2012/0022389 A1 1/2012 Sanders
 2012/0192874 A1 8/2012 Bolea et al.
 2013/0085546 A1 4/2013 Bolea et al.

FOREIGN PATENT DOCUMENTS

EP 1 404 221 B1 2/2007
 EP 1 854 494 A1 11/2007
 EP 1 322 384 B1 12/2007
 JP 53118893 10/1978
 JP 9-294819 11/1997
 JP 2000-506601 5/2000
 JP 2000-508562 7/2000
 JP 2003-305135 10/2003
 JP 2004-508908 3/2004
 JP 2004-532707 10/2004
 JP 3688301 6/2005
 JP 2005-521485 7/2005
 JP 2007-21156 2/2007
 WO WO 98/20938 5/1998
 WO WO 02/024279 3/2002
 WO WO-02/24279 3/2002
 WO WO 03/000133 1/2003
 WO WO 03/000347 A1 1/2003
 WO WO 03/082393 A1 10/2003
 WO WO 2005/004993 A1 1/2005
 WO WO 2006/045251 A1 5/2006
 WO WO 2006/063339 A2 6/2006
 WO WO 2007/134458 A1 11/2007
 WO WO-2008/046190 4/2008

OTHER PUBLICATIONS

Spence et al., "High-flow nasal cannula as a device to provide continuous positive airway pressure in infants," *Journal of Perinatology*, Dec. 2007, pp. 772-775, vol. 27 (12), Nature Publishing Group.

(56)

References Cited

OTHER PUBLICATIONS

Kirkness et al., "Nasal airflow dynamics: mechanisms and responses associated with an external nasal dilator strip," University of Western Sydney, T.C. Amis School of Science, Department of Respiratory Medicine, Westmead Hospital and University of Sydney, Westmead, Australia, 2000.

De Almeida et al., "Nasal pressure recordings to detect obstructive sleep apnea," *Sleep and Breathing*, Feb. 25, 2006, pp. 62-69, vol. 10 (2), Springer Heidelberg.

Saslow et al., "Work of breathing using high-flow nasal cannula in preterm infants," *Journal of Perinatology*, May 11, 2006, pp. 476-480, vol. 26 (8), Nature Publishing Group.

Campbell et al., "Nasal Continuous positive airway pressure from high flow cannula versus Infant Flow for preterm infants," *Journal of Perinatology*, Jul. 2006, pp. 546-549, vol. 26 (9), Nature Publishing Group.

Trevisanuto et al., "A new device for administration of continuous positive airway pressure in preterm infants: comparison with a standard nasal CPAP continuous positive airway pressure system," *Intensive Care Medicine*, Apr. 2005, pp. 859-864, vol. 31 (6), Springer-Verlag.

Verse et al., "New developments in the therapy of obstructive sleep apnea," *European Archives of Oto-Rhino-Laryngology*, Jan. 2001, pp. 31-37, vol. 258 (1), Springer-Verlag.

Paquereau et al., "Positive pressure titration in the treatment of obstructive sleep apnea syndrome using continuous airway positive pressure," *Revue Des Maladies Respiratoires*, Apr. 2000, pp. 459-465, vol. 17 (2), Masson Editeur.

Mahadevia et al., "Effects of expiratory positive airway pressure on sleep-induced respiratory abnormalities in patients with hypersomnia-sleep apnea syndrome," *Am. Rev. Respir. Dis.*, Feb. 1983, vol. 128, pp. 708-711.

Tiran et al., "An Improved Device for Posterior Rhinomanometry to Measure Nasal Resistance," *Journal of Biomechanical Engineering*, Nov. 2005, vol. 127, pp. 994-997.

Noseda et al., "Compliance with nasal continuous positive airway pressure assessed with a pressure monitor: pattern of use and influence of sleep habits," *Chest Clinics and Sleep Laboratories, Hôpitaux Erasme et Brugmann, Université Libre de Bruxelles, Brussels, Belgium*, 2000, vol. 94, pp. 76-81.

Goding Jr. et al., "Relief of Upper Airway Obstruction With Hypoglossal Nerve Stimulation in the Canine," *The Laryngoscope*, Feb. 1998, pp. 162-169, vol. 108, Lippincott-Raven Publishers, U.S.A.

Sahin et al., "Chronic recordings of hypoglossal nerve activity in a dog model of upper airway obstruction," *Journal of Applied Physiology* 87(6), 1999, The American Physiological Society, pp. 2197-2206.

Extended European Search Report for EP Application No. 15192695.3 dated Mar. 2, 2016, 7 pages.

Huang et al. "Dilation of the oropharynx via selective stimulation of the hypoglossal nerve." *J. Neural Eng.* 2005; 2:73-80.

Isono et al., "Interaction of cross-sectional area, driving pressure, and airflow of passive velopharynx," *American Physiological Society*, 1997, pp. 851-859, vol. 83.

Oliven et al., "Effect of genioglossus contraction on pharyngeal lumen and airflow in sleep apnea patients," *European Respiratory Journal*, 2007, pp. 748-758, vol. 30, No. 4.

* cited by examiner

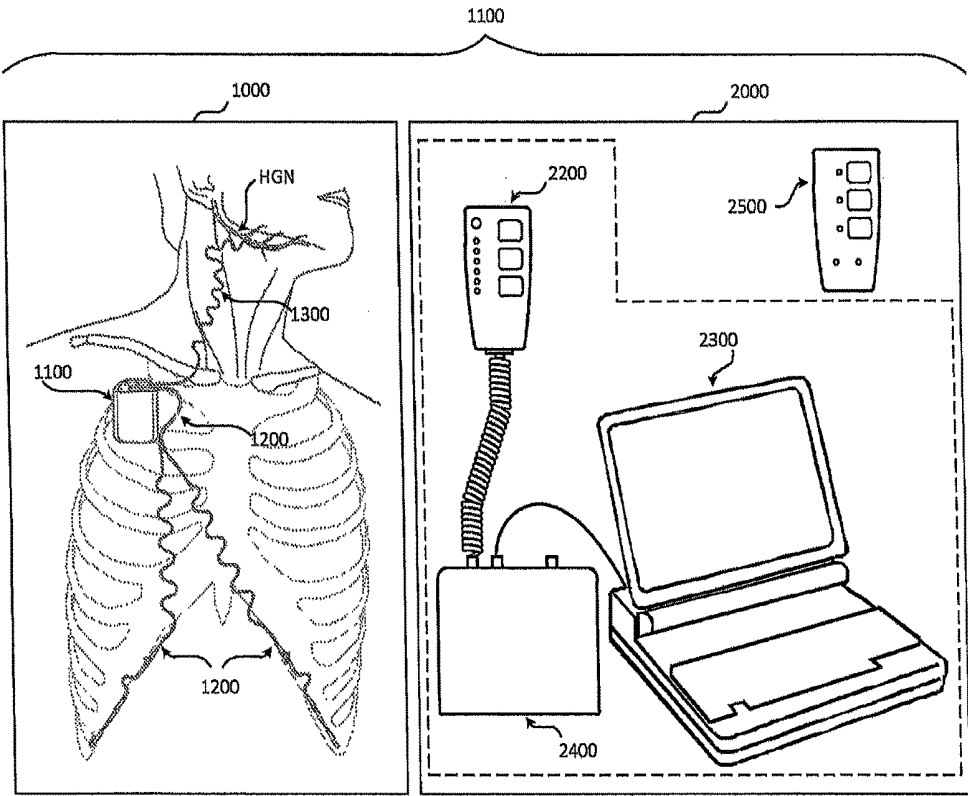

FIG. 1

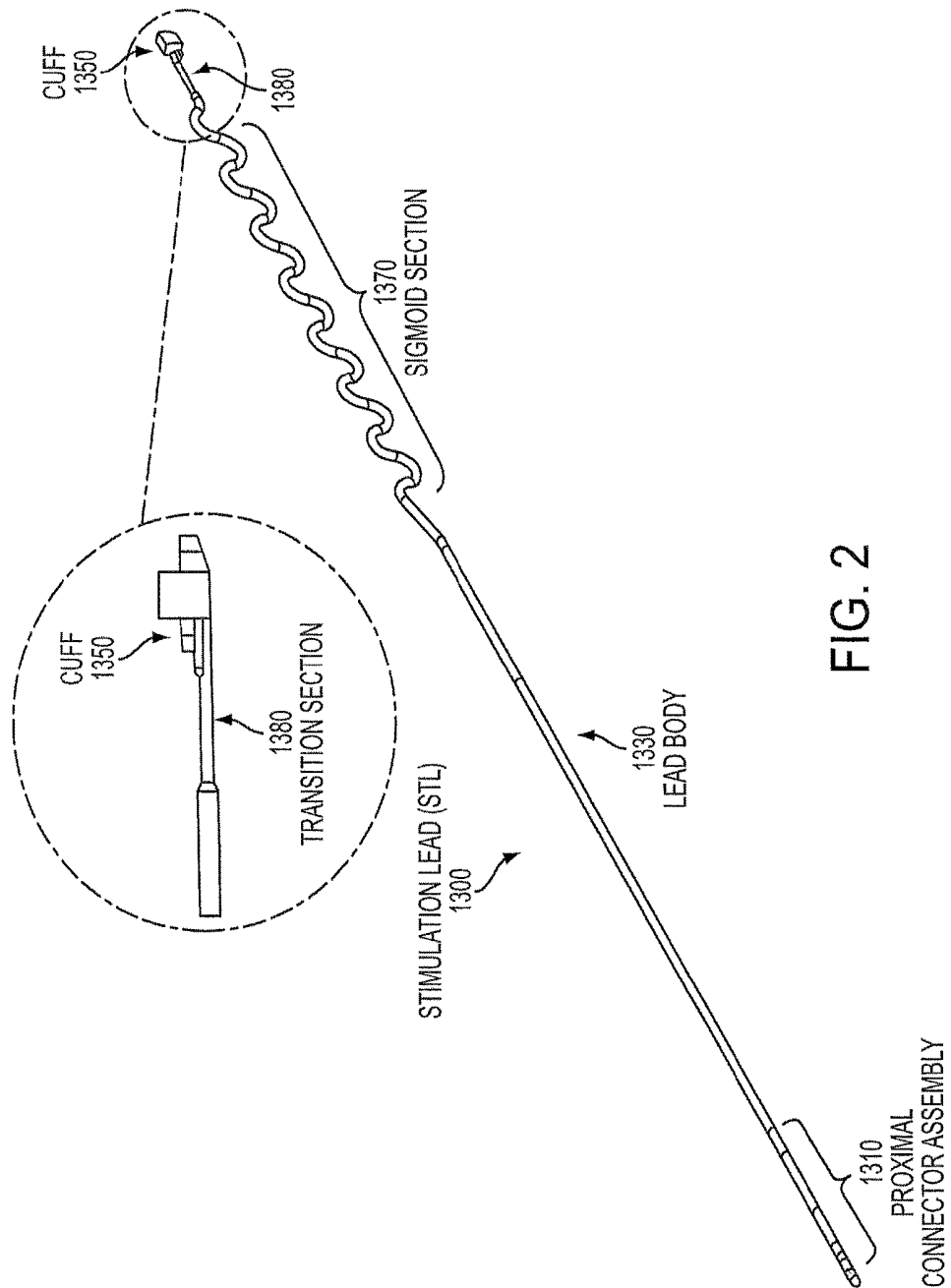

FIG. 2

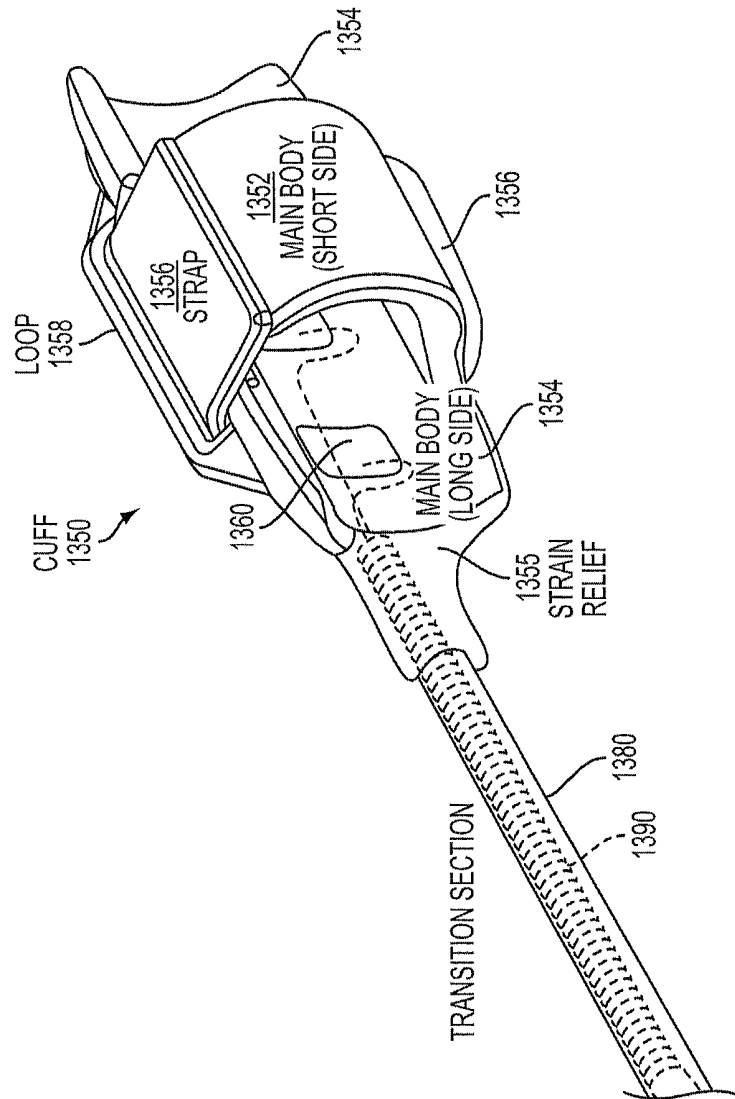

FIG. 3A

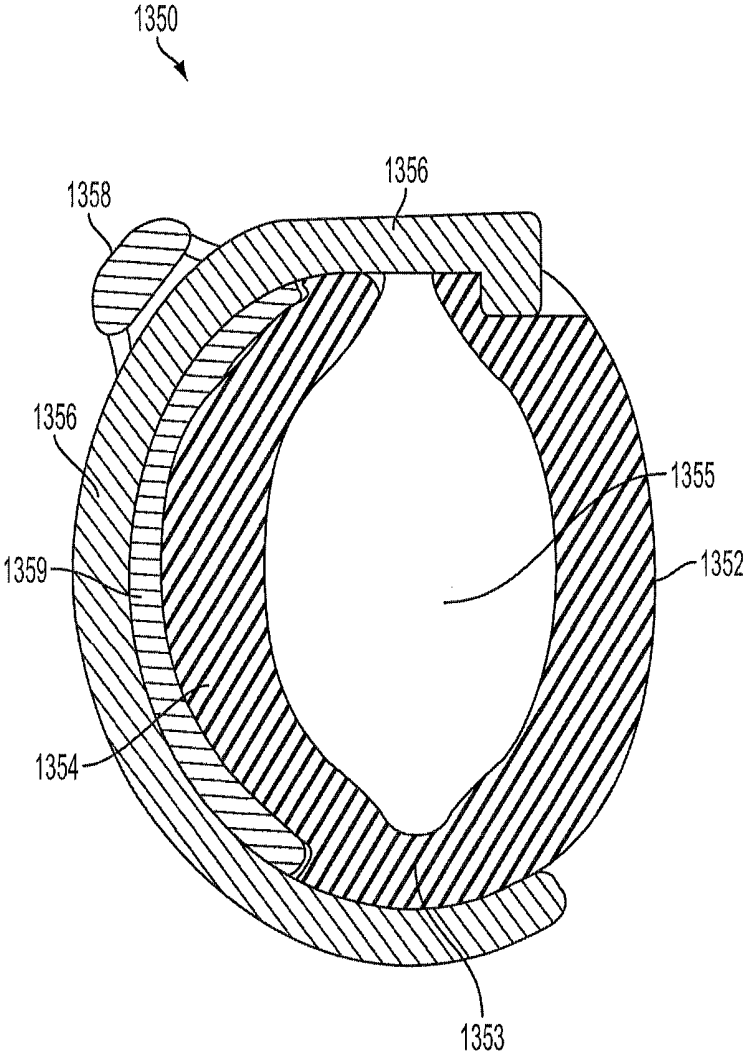

FIG. 3B

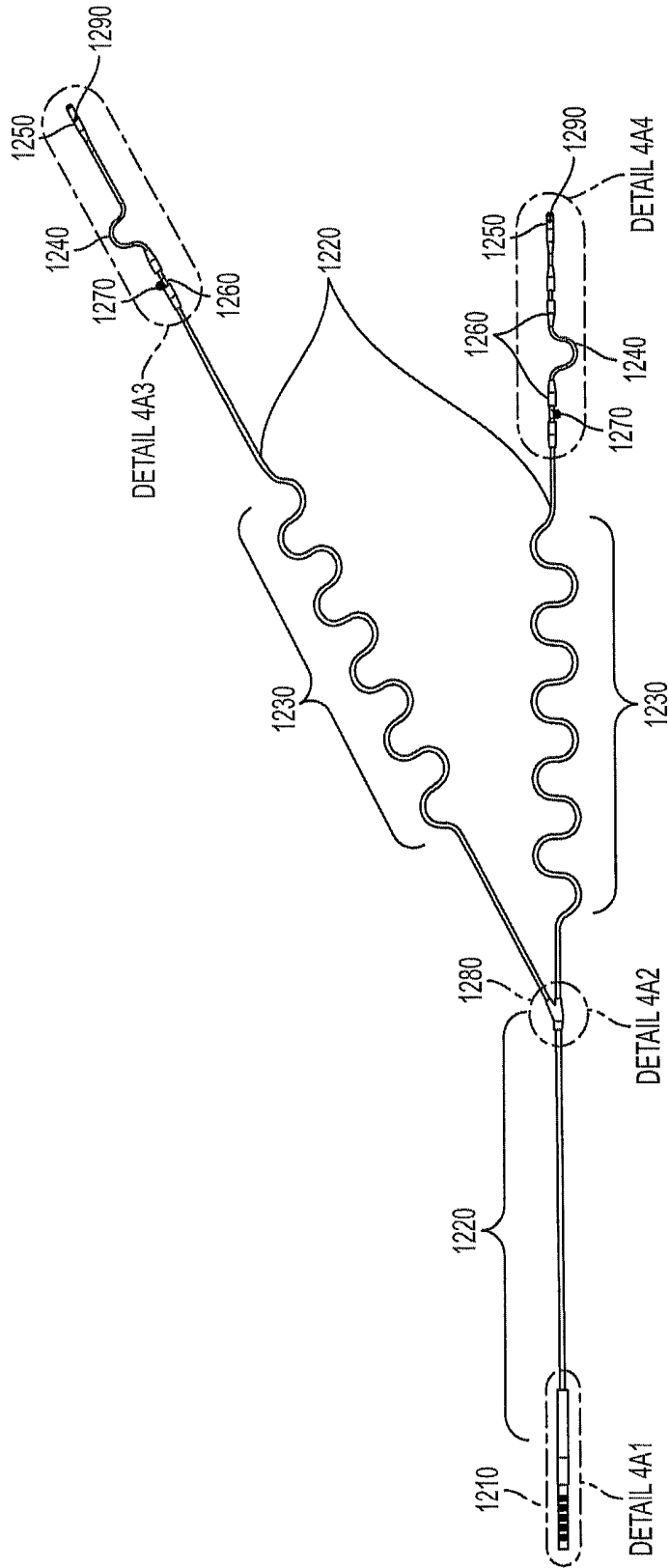

FIG. 4A

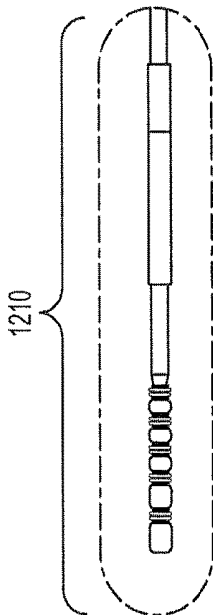

FIG. 4A1

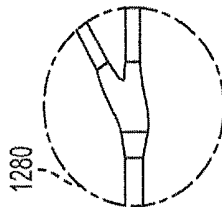

FIG. 4A2

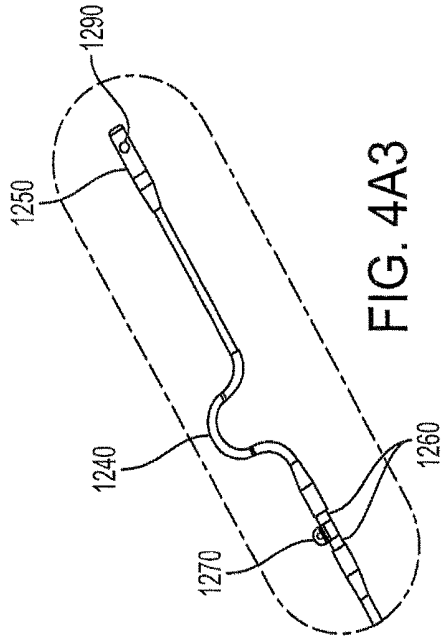

FIG. 4A3

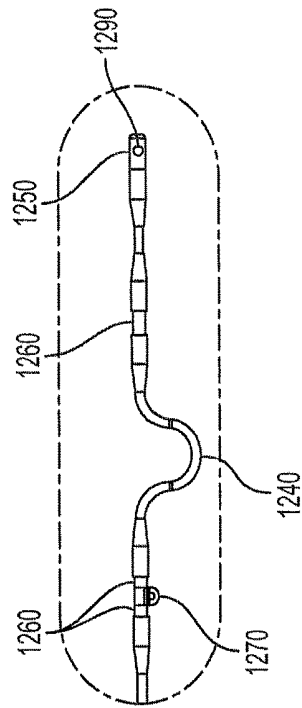

FIG. 4A4

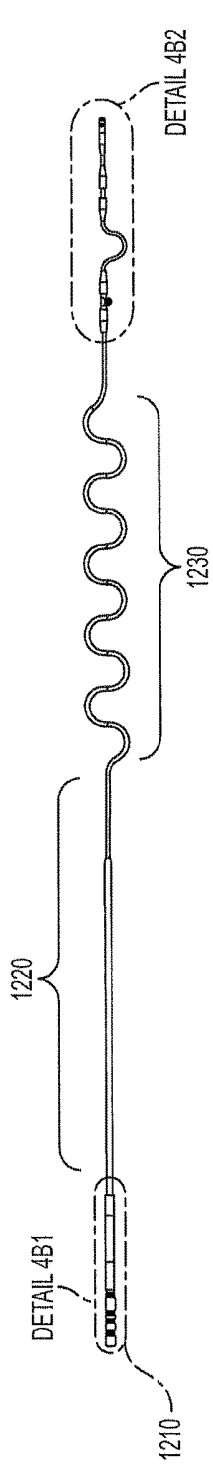

FIG. 4B



FIG. 4B1

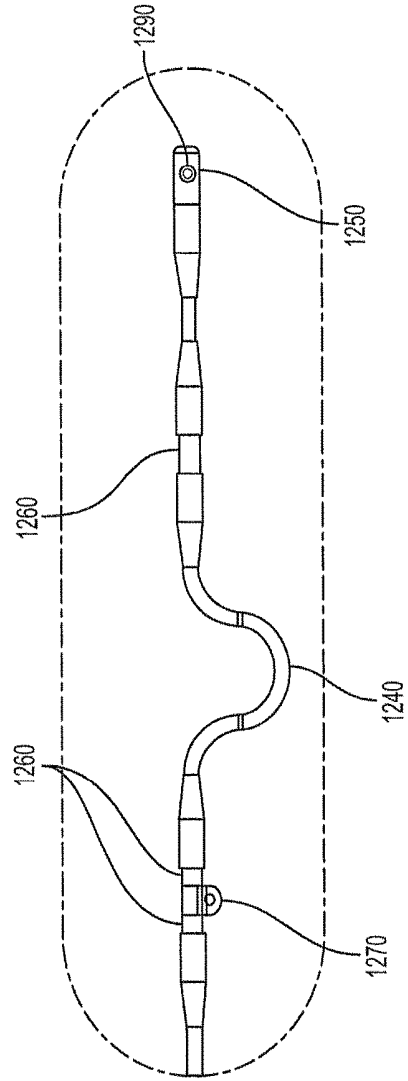

FIG. 4B2

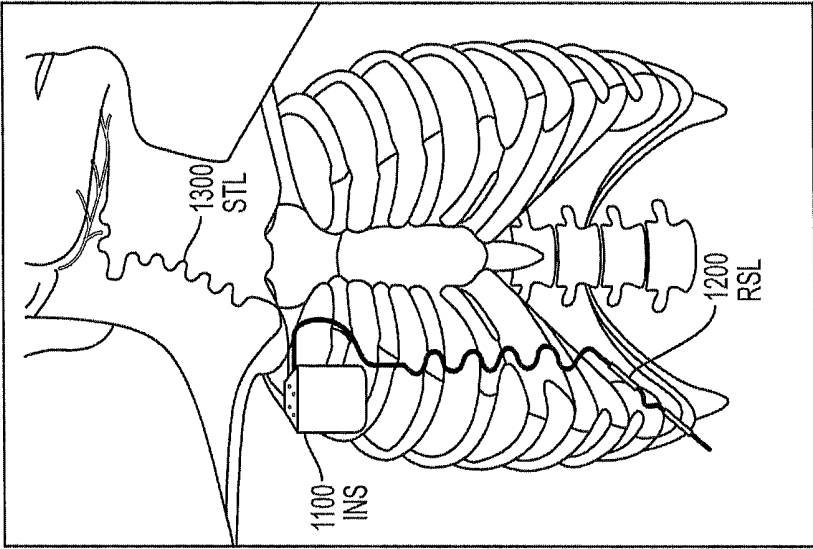

FIG. 4D

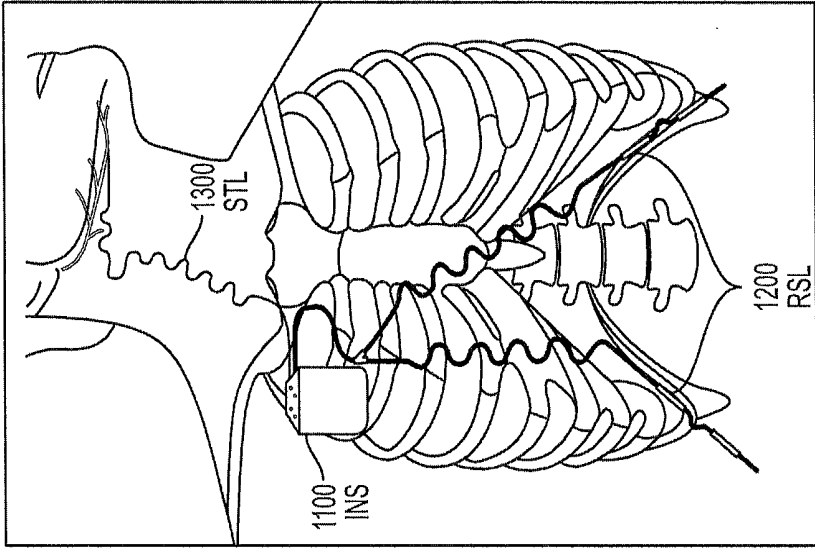

FIG. 4C

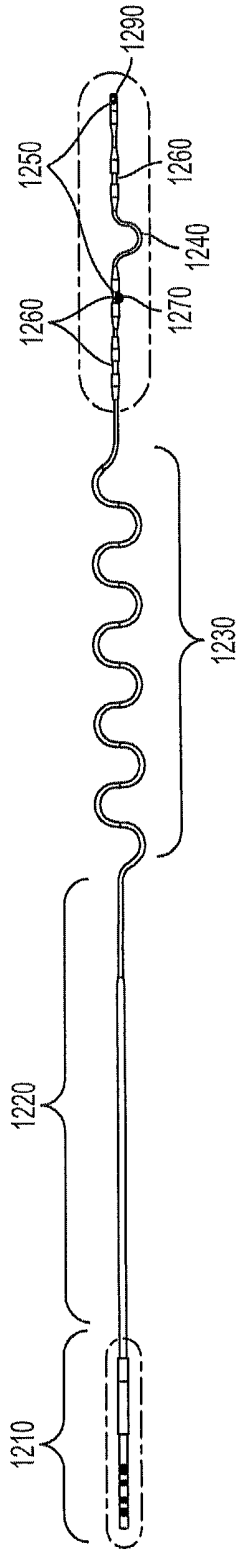

FIG. 4E

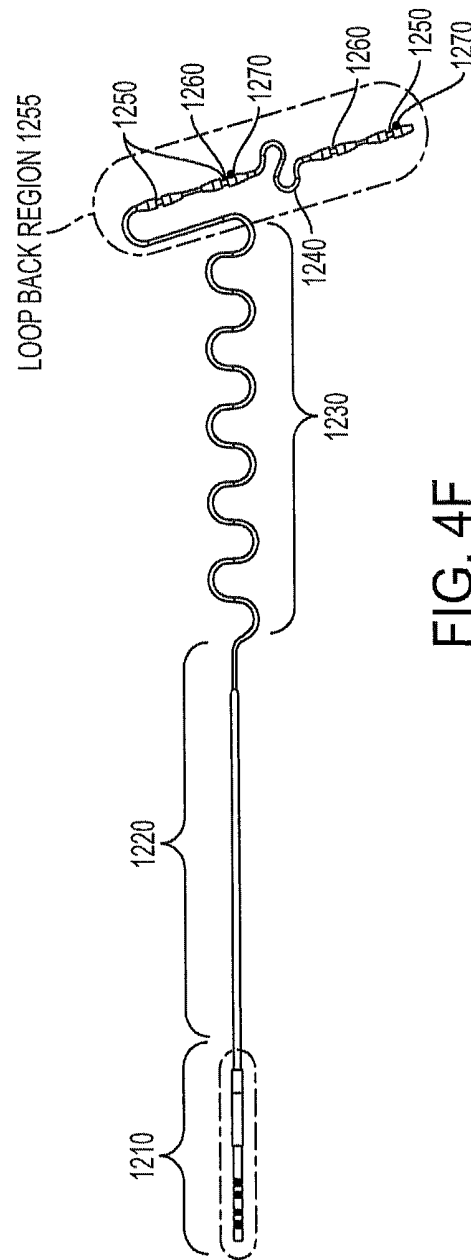

FIG. 4F

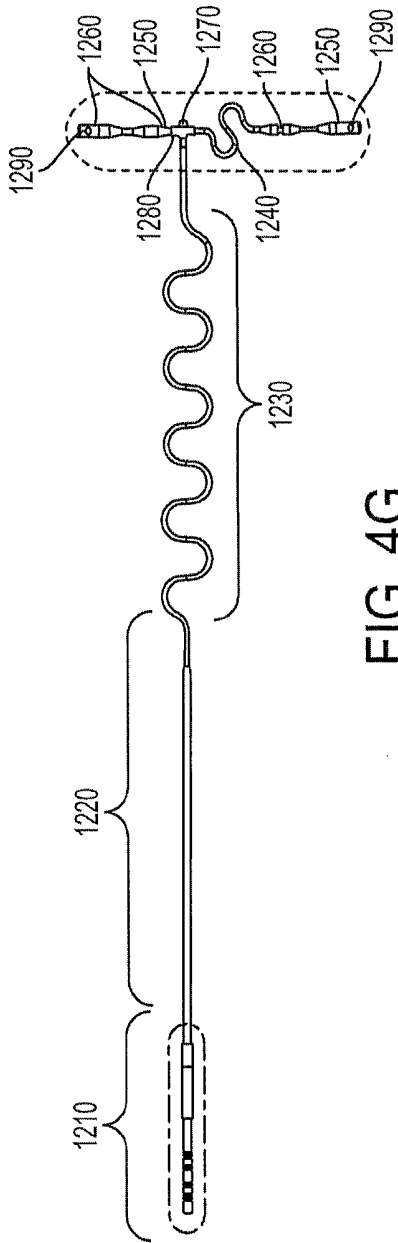

FIG. 4G

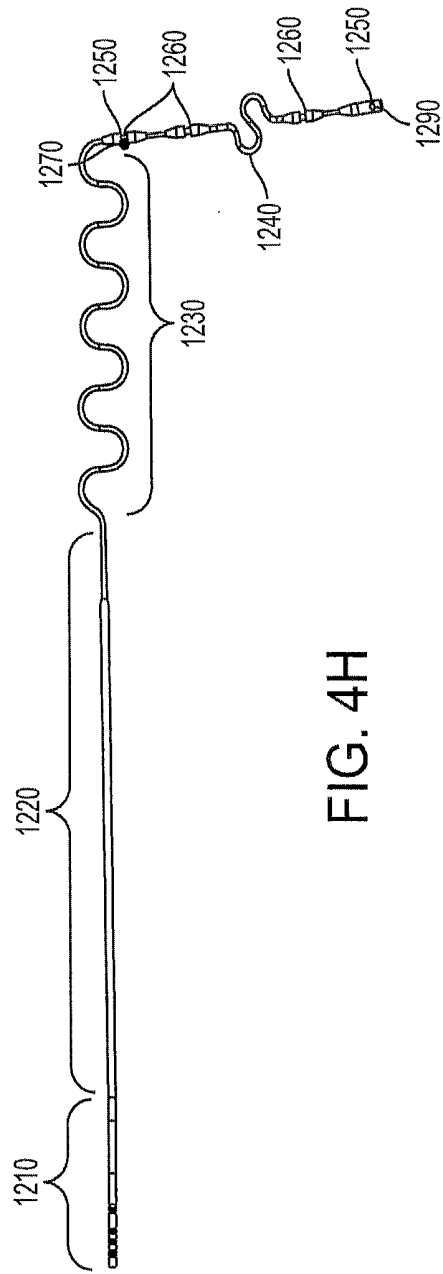

FIG. 4H

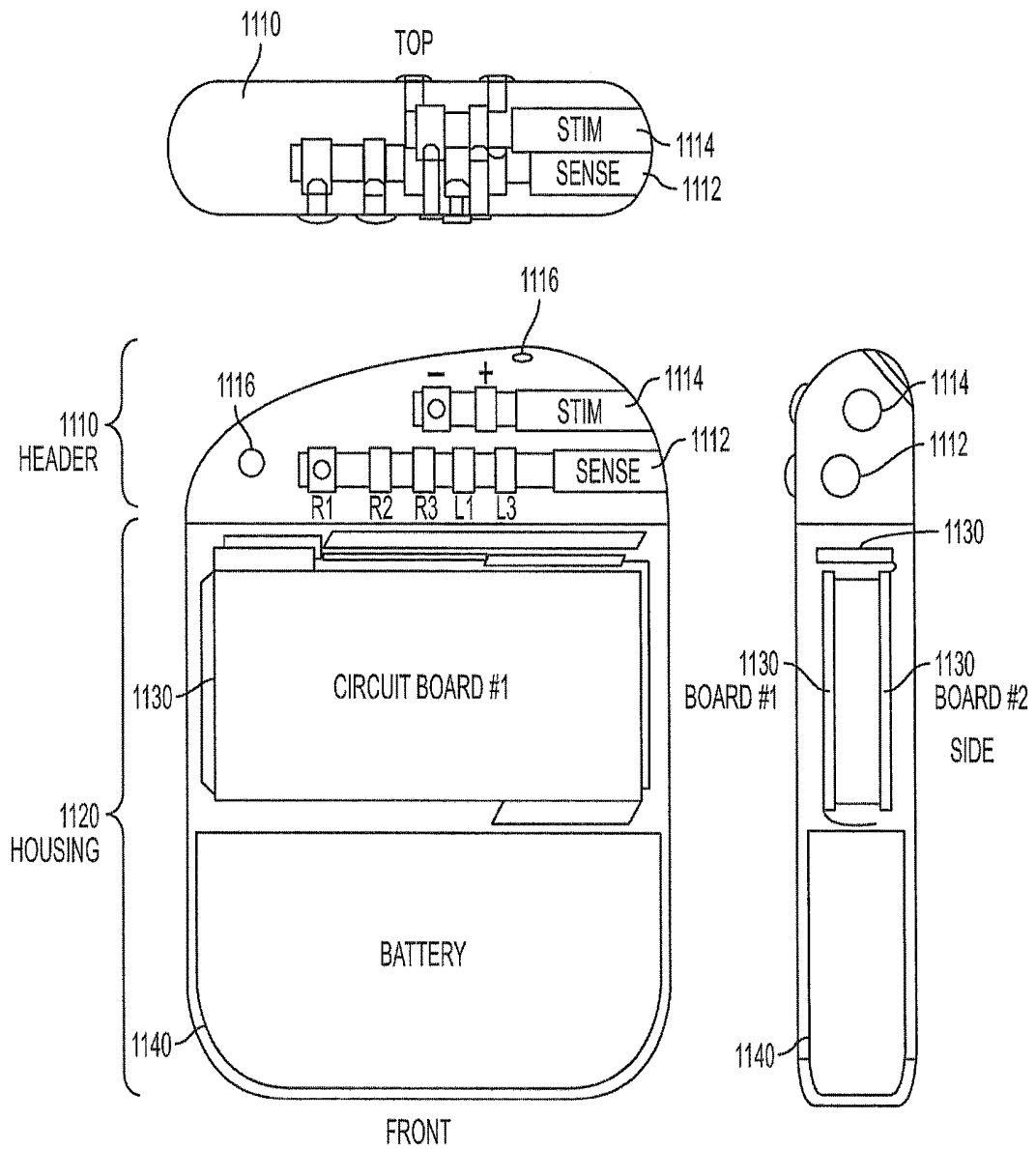

FIG. 5A

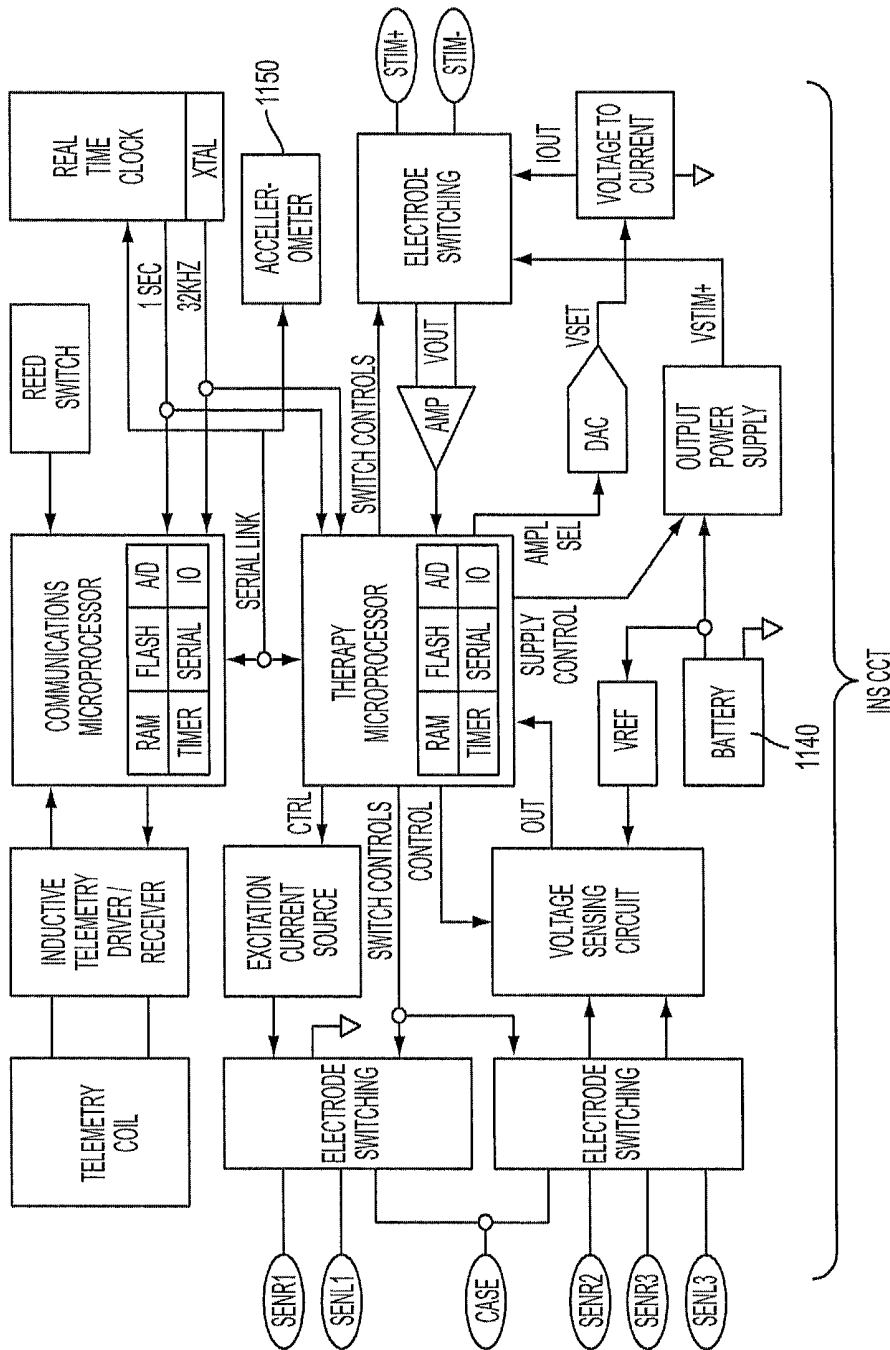

FIG. 5B

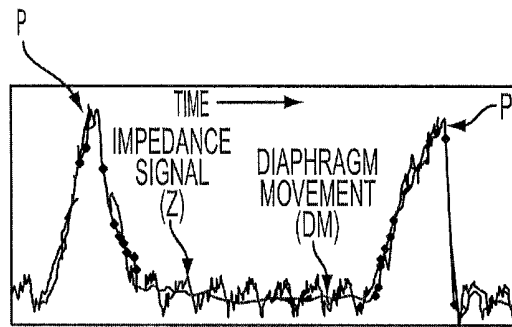

FIG. 6A

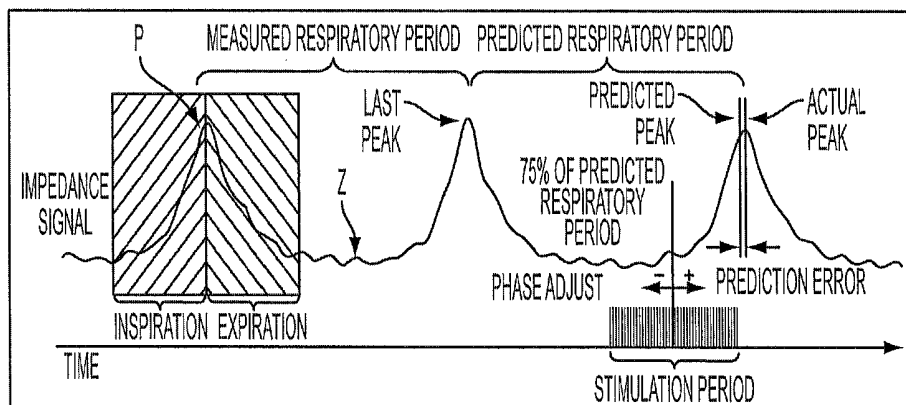

FIG. 6B

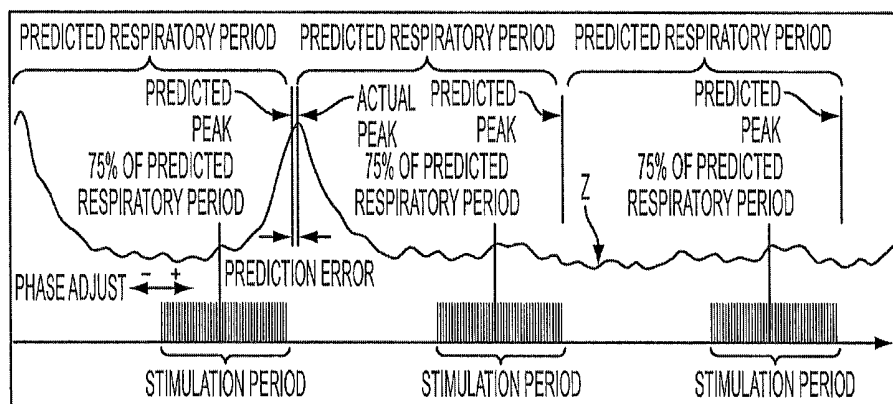
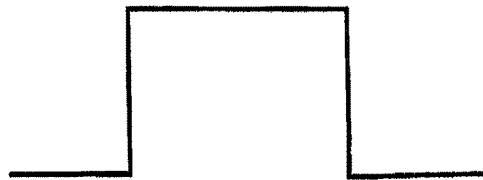

FIG. 6C

FIG. 6D



Default Stimulation

FIG. 6E

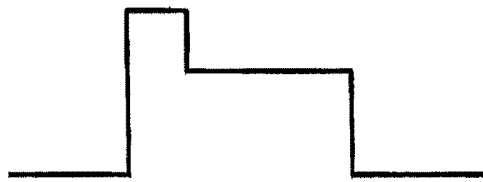

Basic Retention Intensity

FIG. 6F

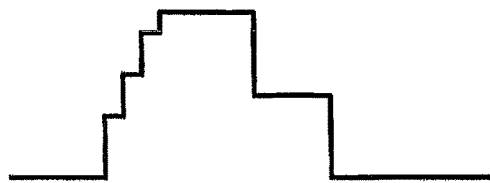

Retention Intensity

FIG. 6G

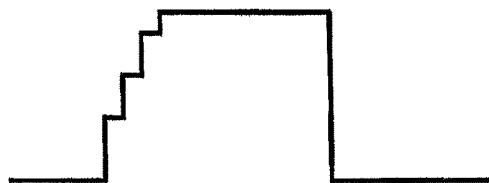

Soft Start

FIG. 6H

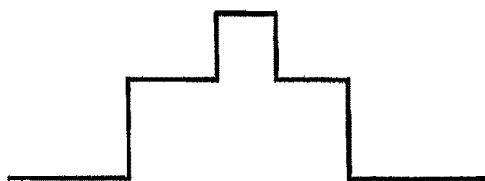

Nested Stimulation

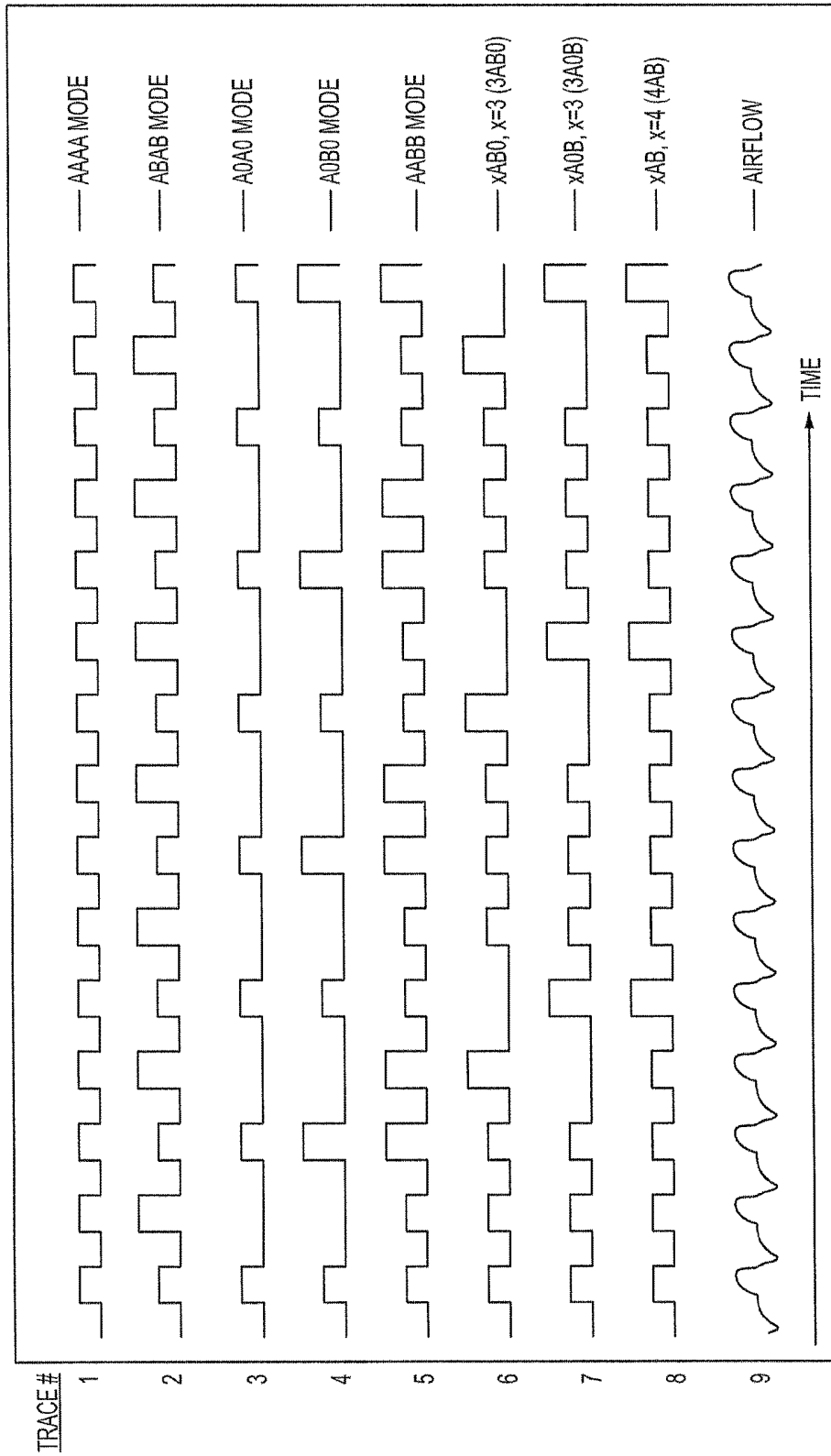

FIG. 6I

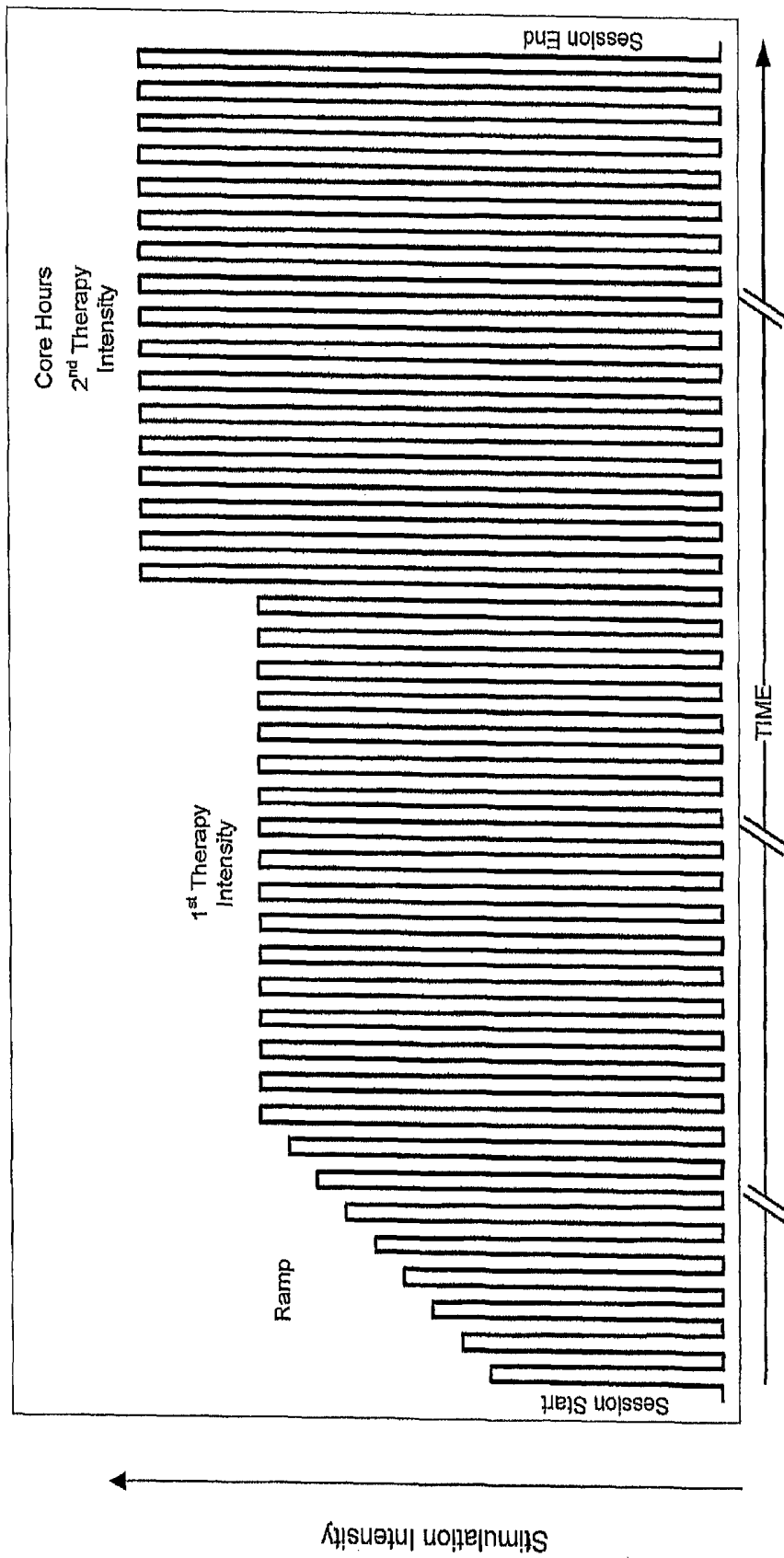

FIG. 6J

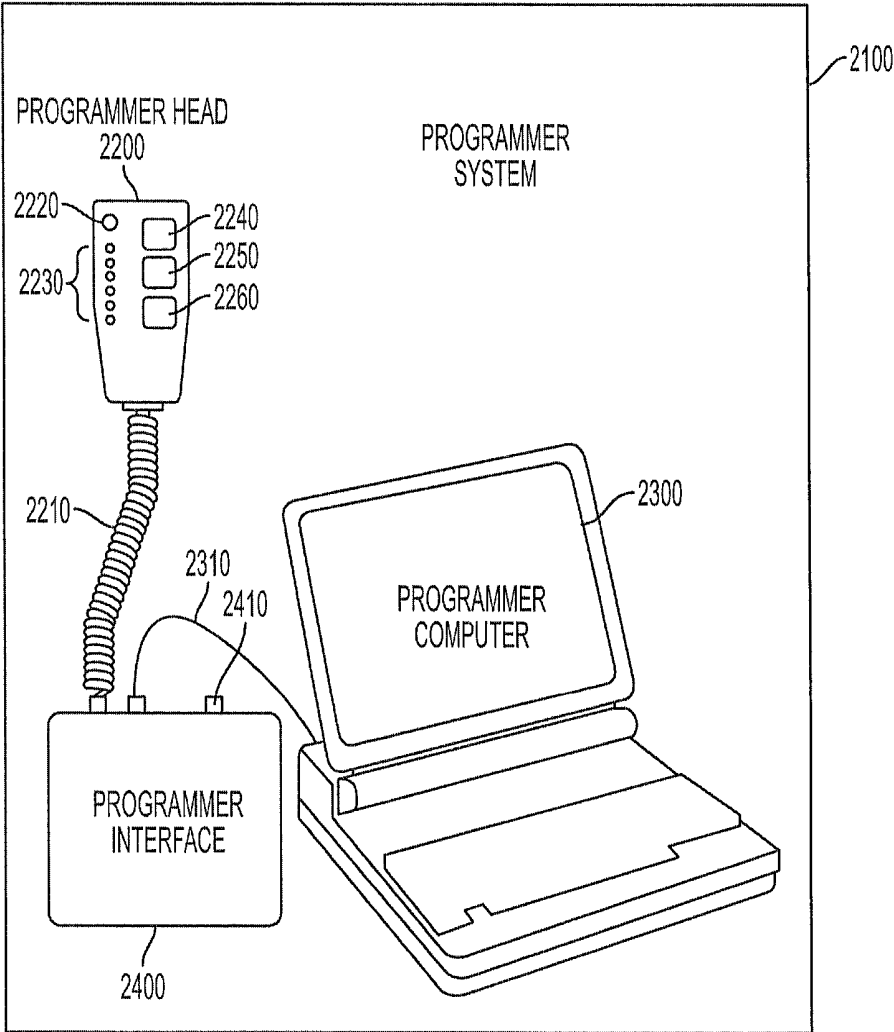

FIG. 7A

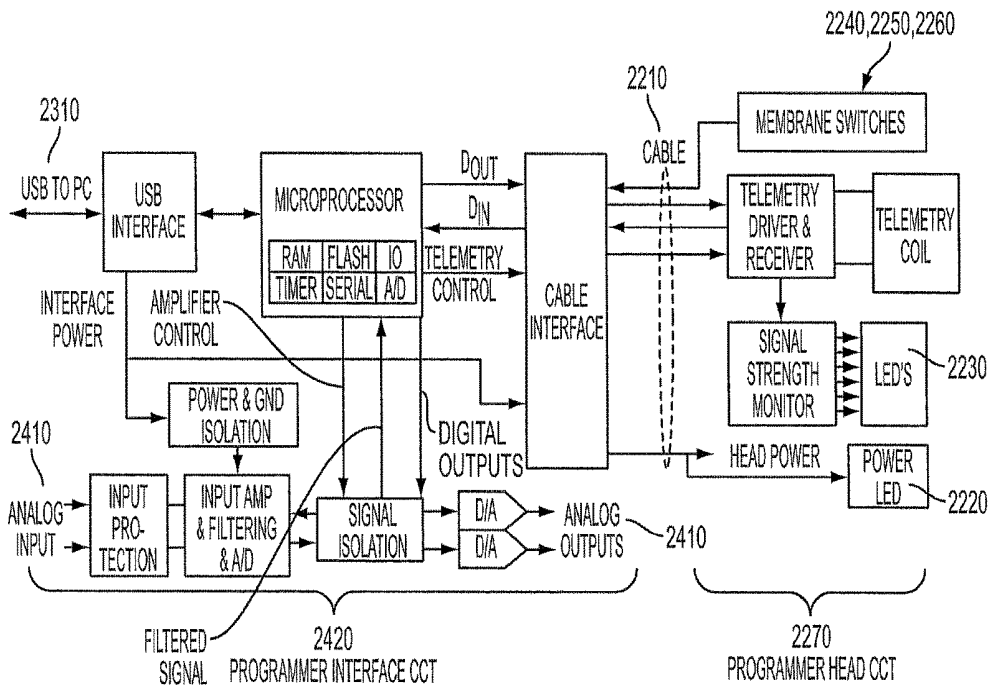

FIG. 7B

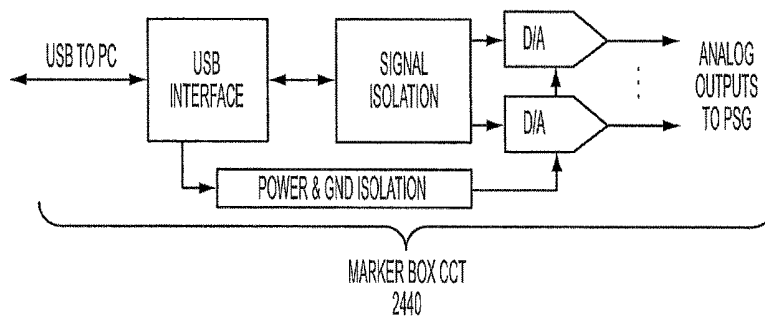

FIG. 7C

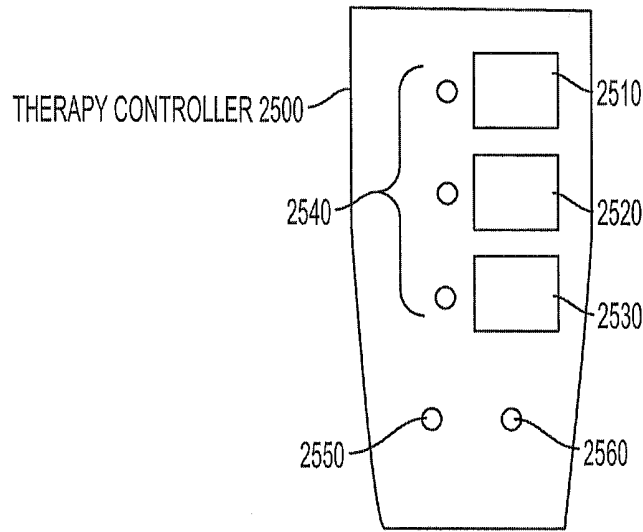

FIG. 8A

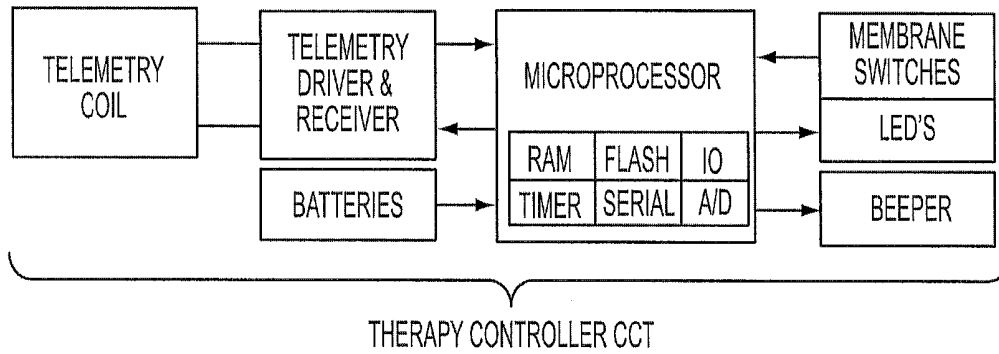

FIG. 8B

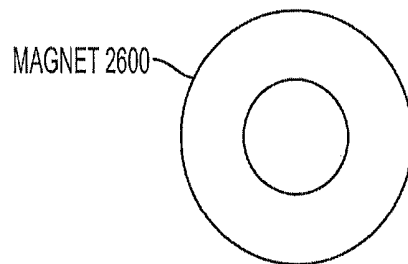

FIG. 9

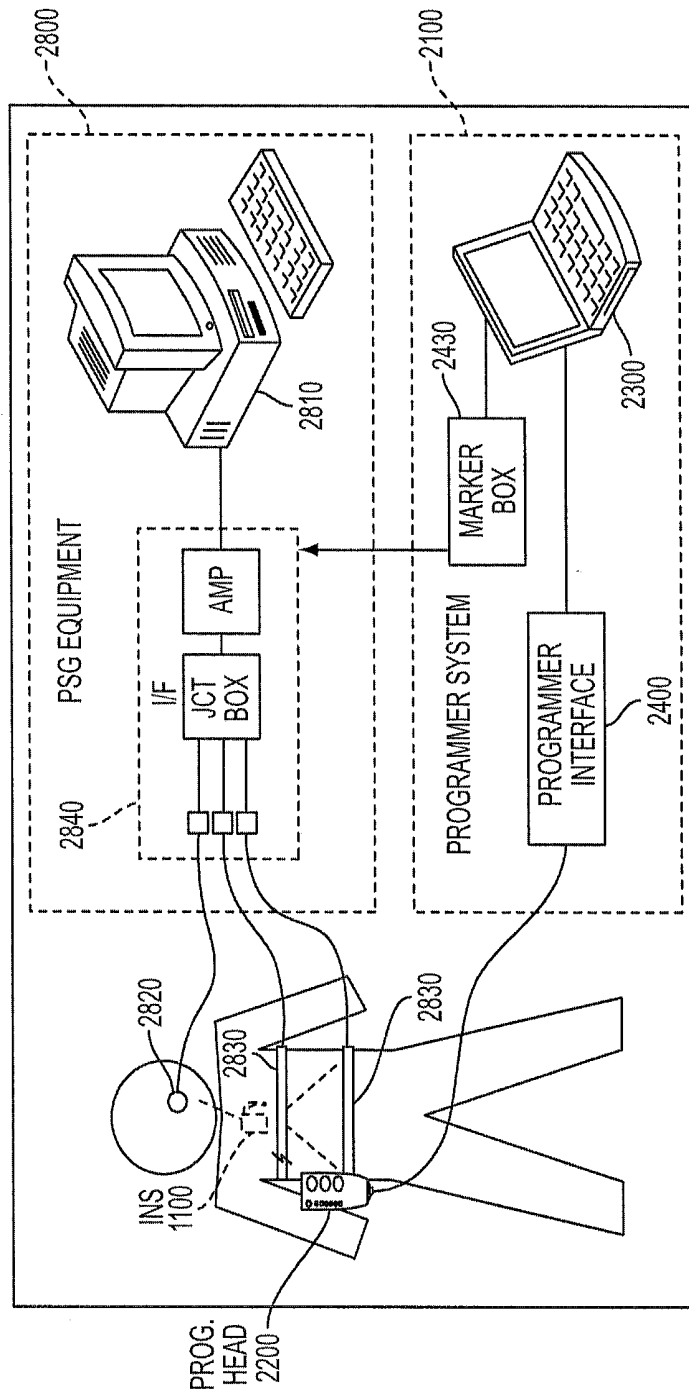

FIG. 10

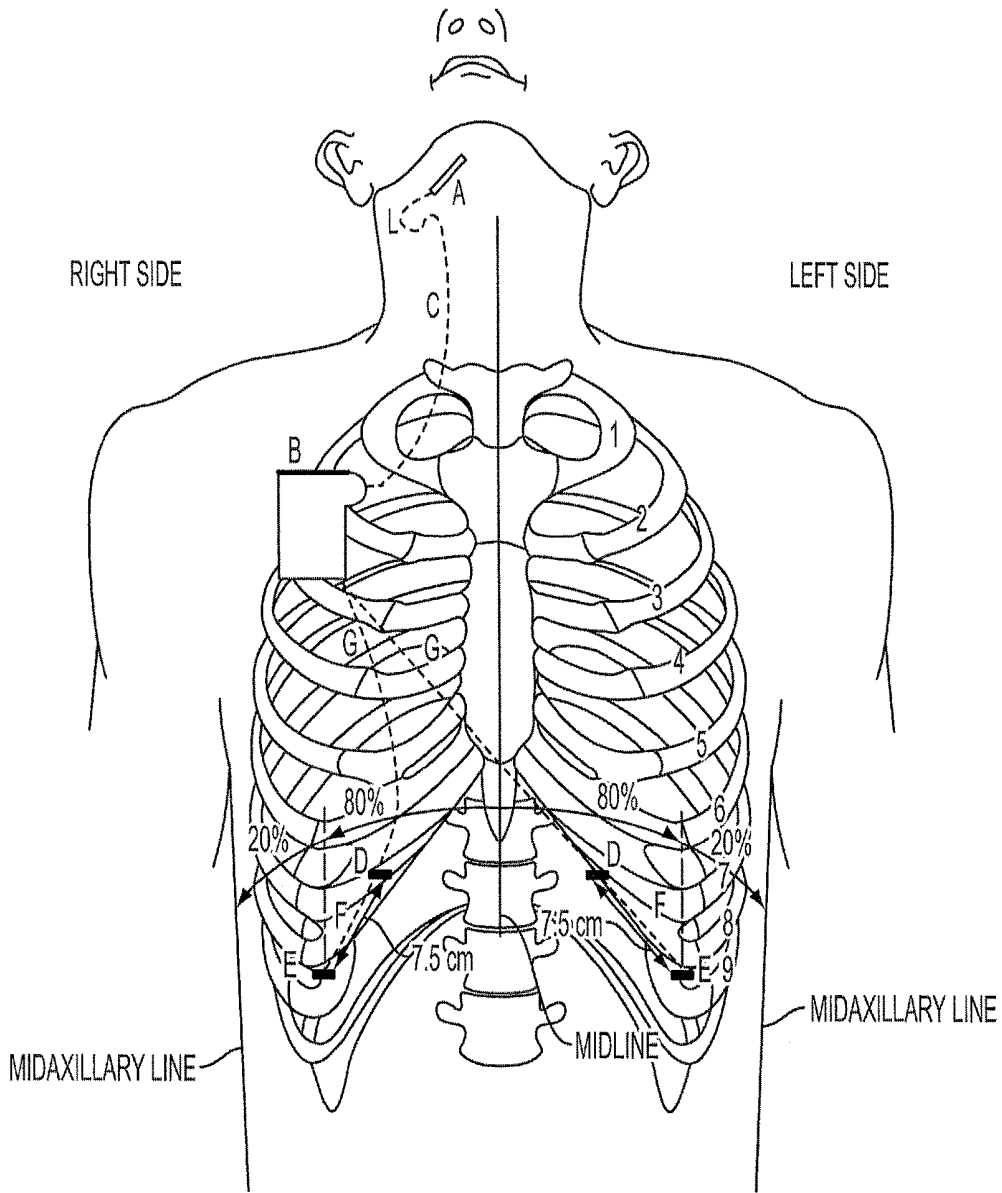

FIG. 11A

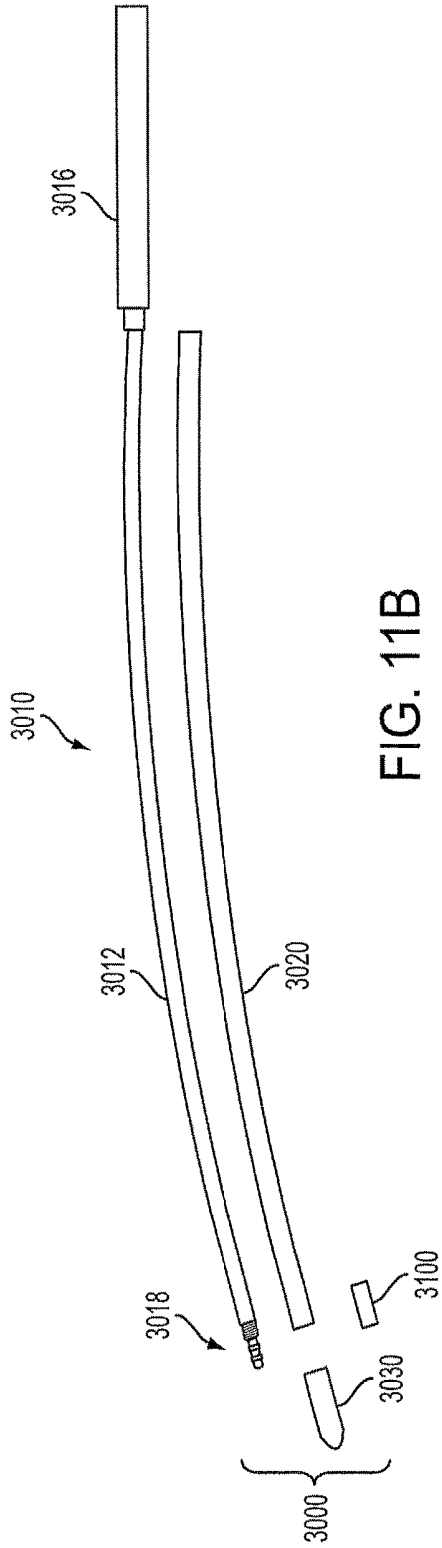

FIG. 11B

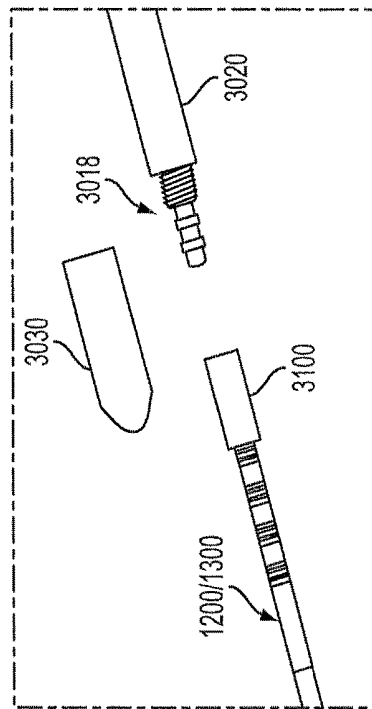

FIG. 11C

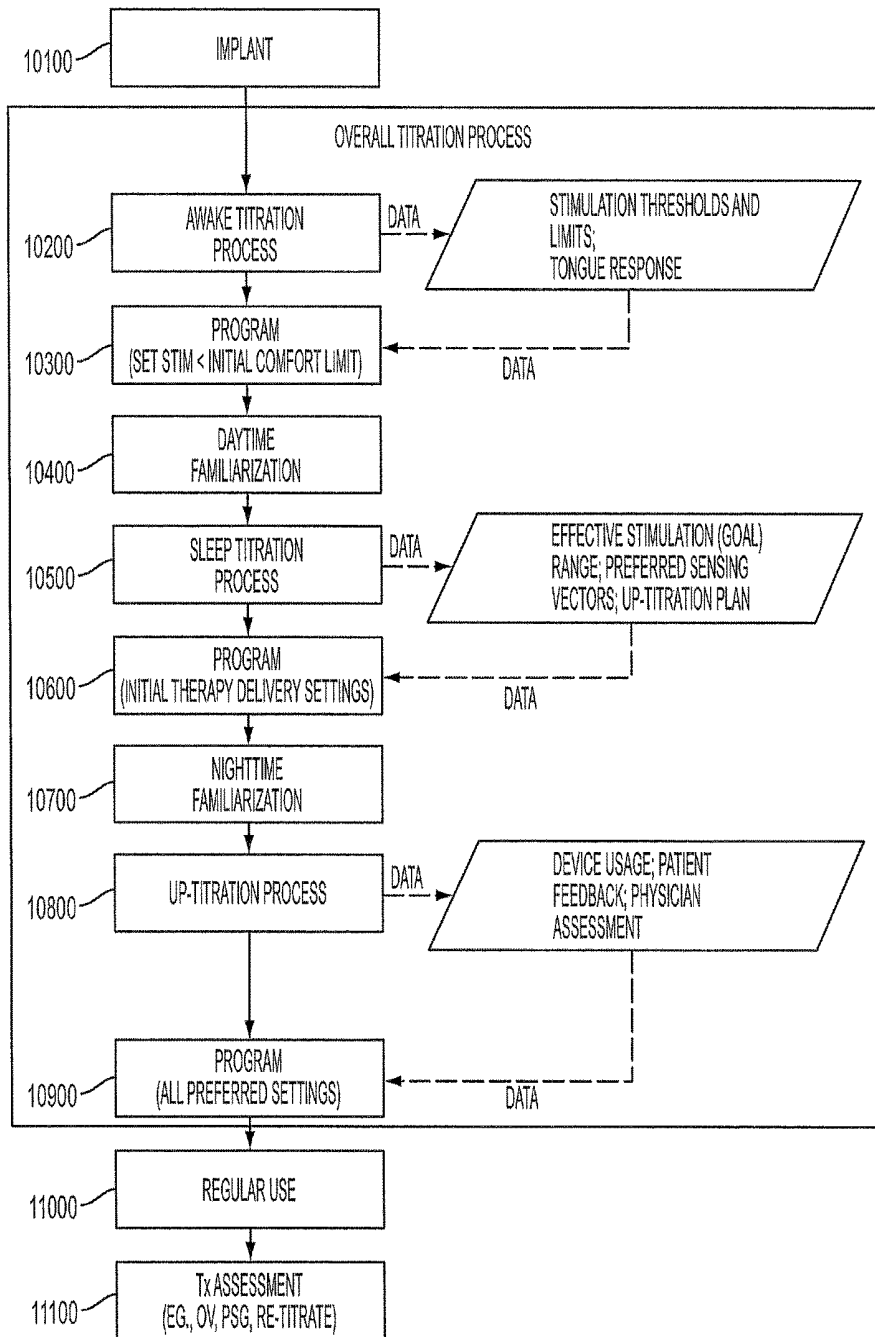

FIG. 12A

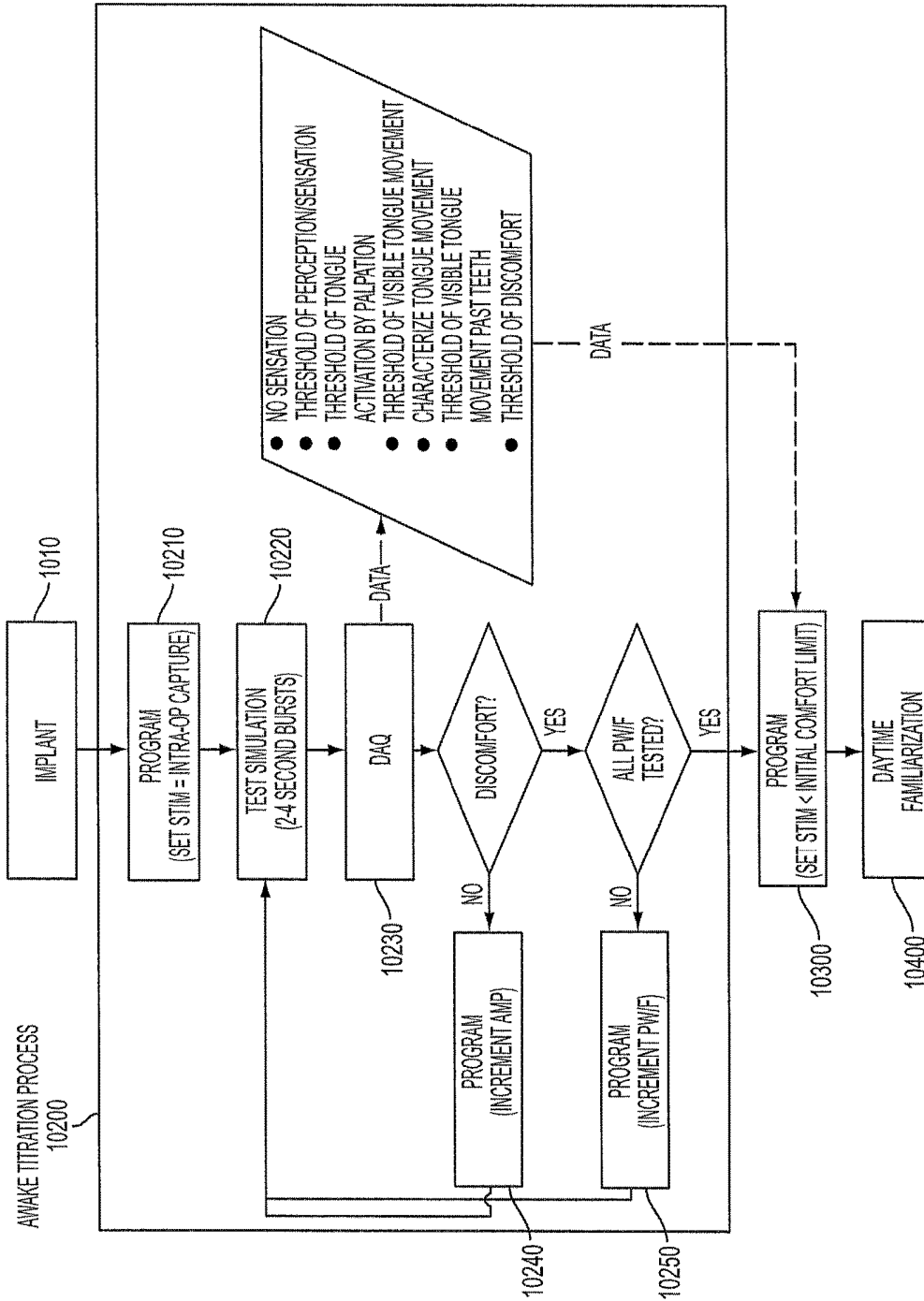

FIG. 12B

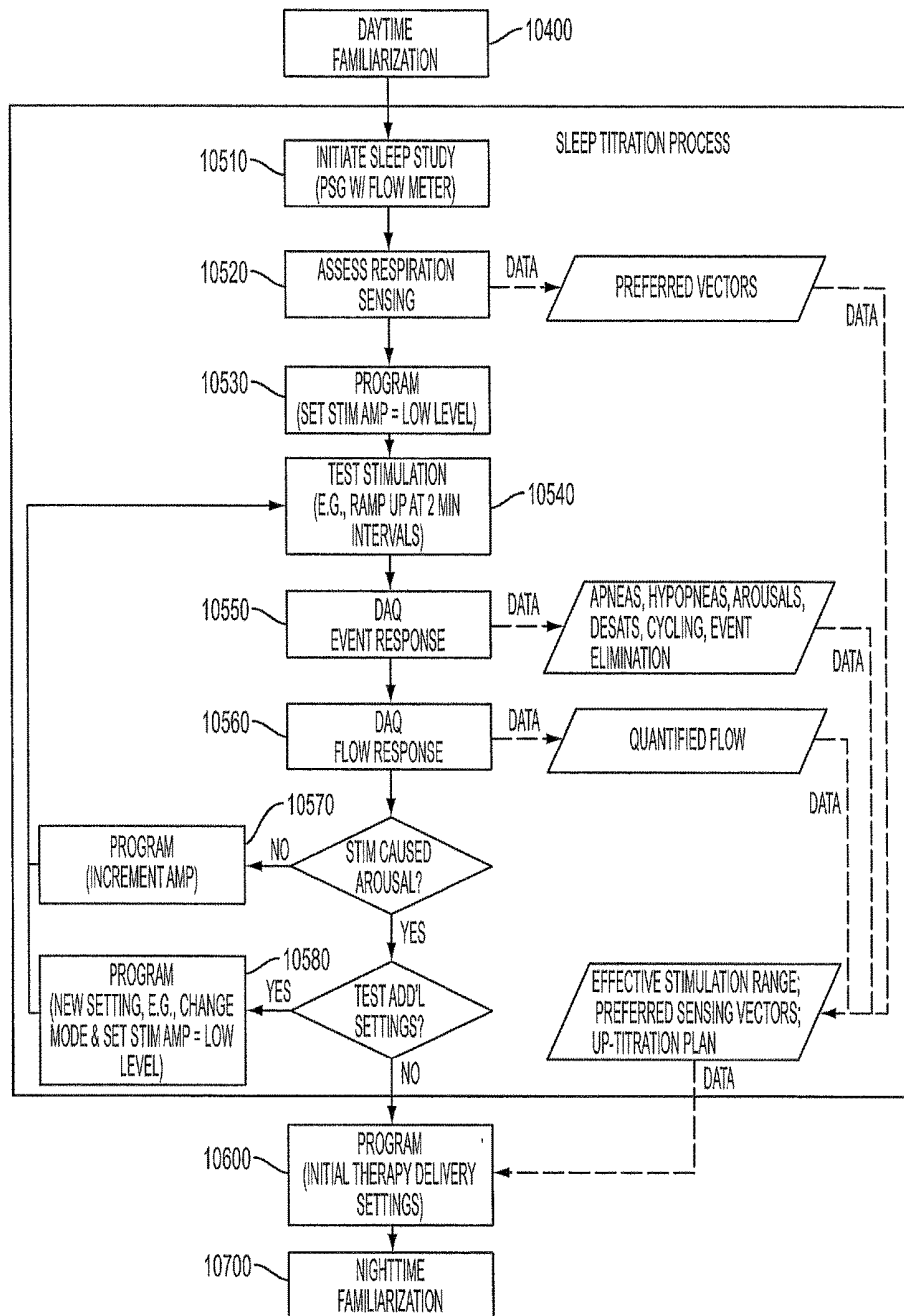

FIG. 12C

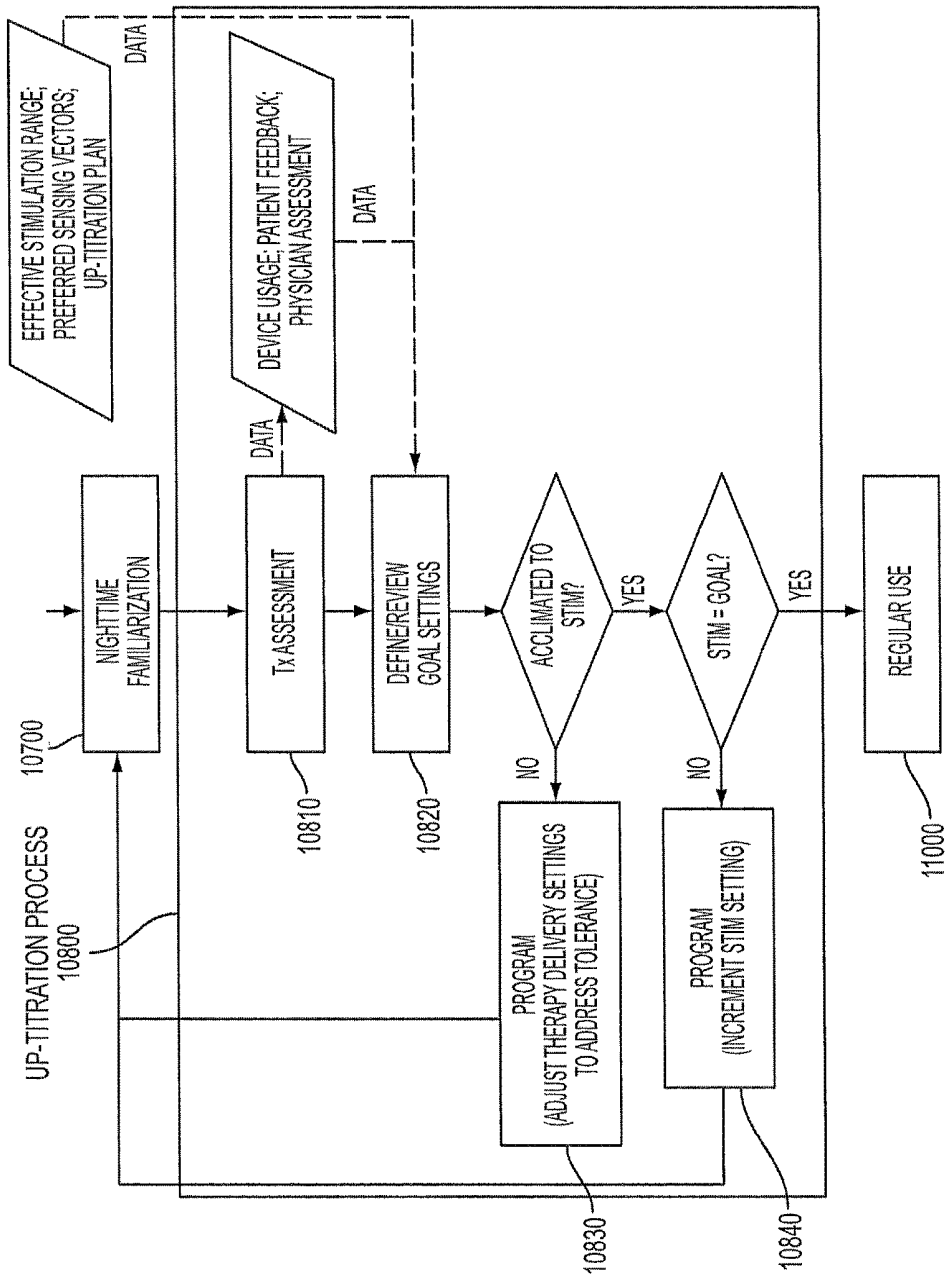

FIG. 12D

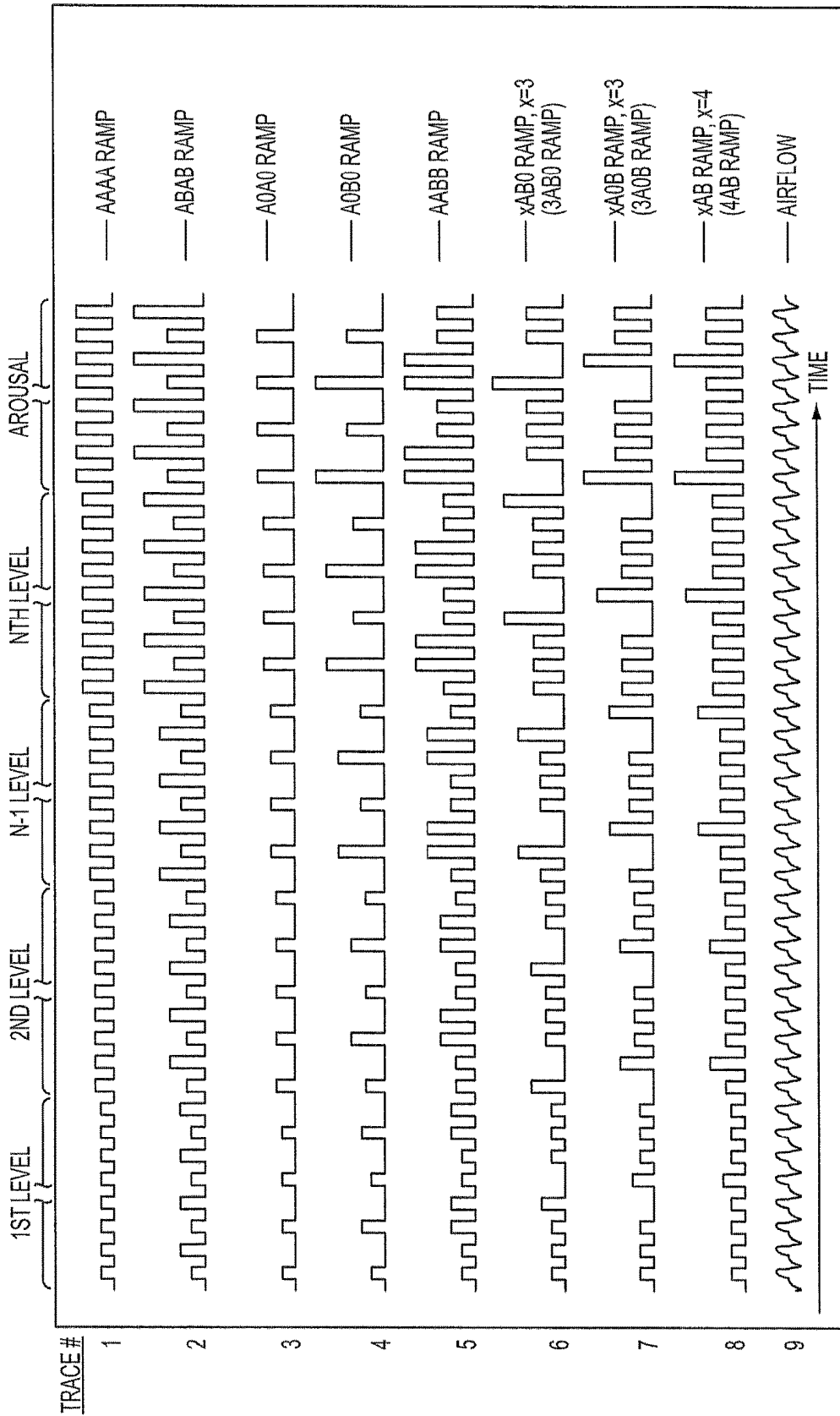

FIG. 13

Example of Airflow Response to Stimulation

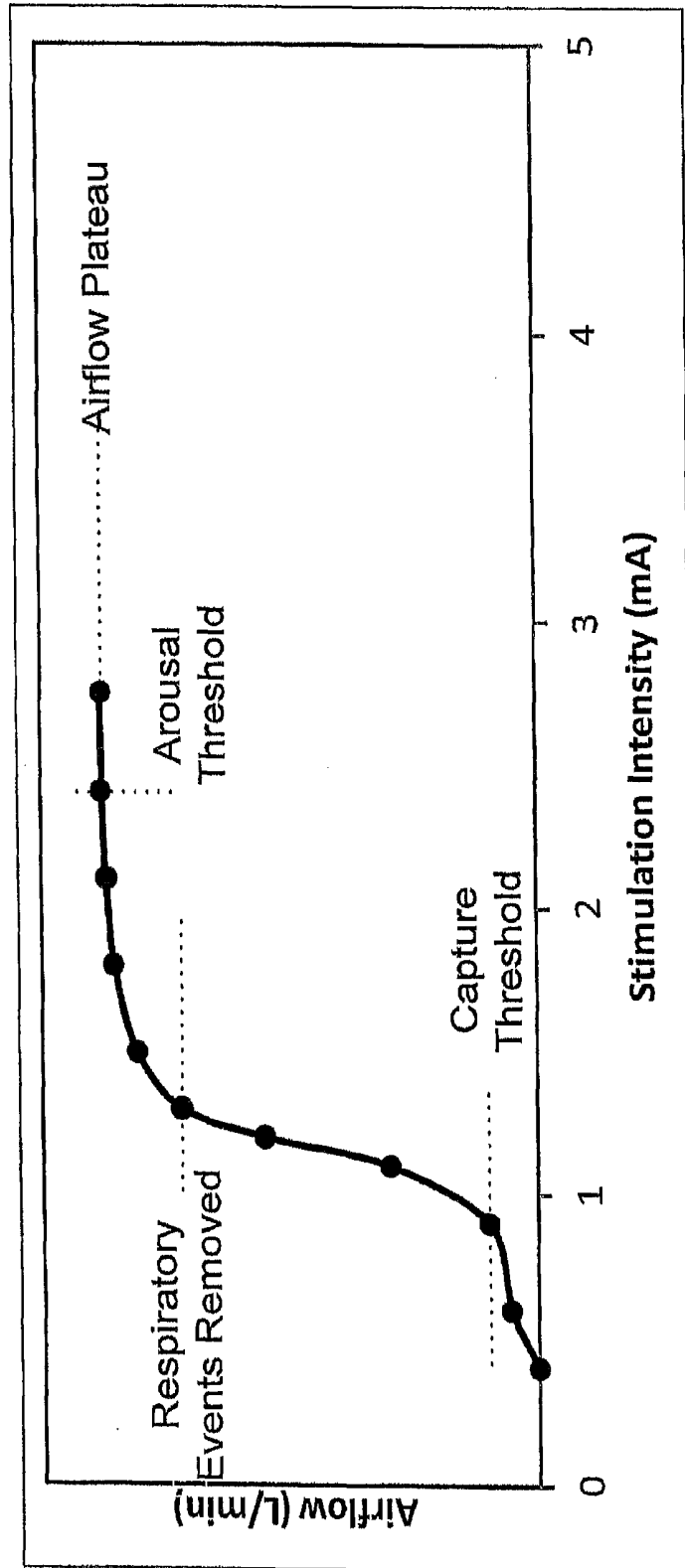

Fig. 14

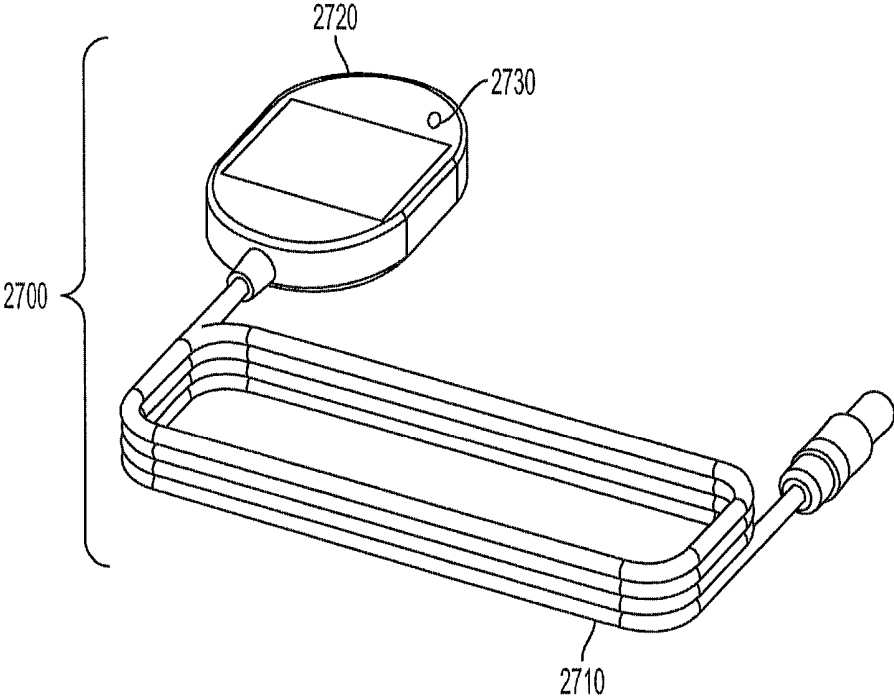

FIG. 15

OBSTRUCTIVE SLEEP APNEA TREATMENT DEVICES, SYSTEMS AND METHODS

CROSS-REFERENCE TO RELATED APPLICATIONS

This patent application claims the benefits of priority under 35 U.S.C. § 119 and 120 to U.S. Provisional Patent Application No. 61/437,573, filed on Jan. 28, 2011, entitled Obstructive Sleep Apnea Treatment Devices, Systems, and Methods, the entire disclosure of which is incorporated herein by reference.

FIELD OF THE INVENTION

The inventions described herein relate to devices, systems and associated methods for treating sleep disordered breathing. More particularly, the inventions described herein relate to devices, systems and methods for treating obstructive sleep apnea.

BACKGROUND OF THE INVENTION

Obstructive sleep apnea (OSA) is highly prevalent, affecting one in five adults in the United States. One in fifteen adults has moderate to severe OSA requiring treatment. Untreated OSA results in reduced quality of life measures and increased risk of disease including hypertension, stroke, heart disease, etc.

Continuous positive airway pressure (CPAP) is a standard treatment for OSA. While CPAP is non-invasive and highly effective, it is not well tolerated by patients. Patient compliance for CPAP is often reported to be between 40% and 60%.

Surgical treatment options for OSA are available too. However, they tend to be highly invasive (result in structural changes), irreversible, and have poor and/or inconsistent efficacy. Even the more effective surgical procedures are undesirable because they usually require multiple invasive and irreversible operations, they may alter a patient's appearance (e.g., maxillo-mandibular advancement), and/or they may be socially stigmatic (e.g., tracheostomy).

U.S. Pat. No. 4,830,008 to Meer proposes hypoglossal nerve stimulation as an alternative treatment for OSA. An example of an implanted hypoglossal nerve stimulator for OSA treatment is the Inspire™ technology developed by Medtronic, Inc. (Fridley, Minn.). The Inspire device is not FDA approved and is not for commercial sale. The Inspire device includes an implanted neurostimulator, an implanted nerve cuff electrode connected to the neurostimulator by a lead, and an implanted intra-thoracic pressure sensor for respiratory feedback and timing of stimulation delivery. The Inspire device was shown to be efficacious (approximately 75% response rate as defined by a 50% or more reduction in RDI (Respiratory Disturbance Index) and a post RDI of ≤ 20) in an eight patient human clinical study, the results of which were published by Schwartz et al. and Eisele et al. However, both authors reported that only three of eight patients remained free from device malfunction, thus demonstrating the need for improvements.

SUMMARY OF THE INVENTION

To address this and other unmet needs, the present invention provides, in exemplary non-limiting embodiments,

devices, systems and methods for nerve stimulation for OSA therapy as described in the following detailed description.

BRIEF DESCRIPTION OF THE DRAWINGS

It is to be understood that both the foregoing summary and the following detailed description are exemplary. Together with the following detailed description, the drawings illustrate exemplary embodiments and serve to explain certain principles. In the drawings:

FIG. 1 is a schematic illustration of a system according to an embodiment of the present invention, including internal (chronically implanted) and external components;

FIG. 2 is a perspective view of a stimulation lead for use in the system shown in FIG. 1, including a detailed view of the distal end of the stimulation lead;

FIG. 3A is a detailed perspective view of the cuff of the stimulation lead shown in FIG. 2;

FIG. 3B is a lateral cross-sectional view of the cuff shown in FIGS. 2 and 3A;

FIG. 4A is a perspective view of a bifurcated respiration sensing lead which may be used in the system shown in FIG. 1;

FIG. 4A1 is a detailed perspective view of the proximal connector assembly of the respiration sensing lead shown in FIG. 1;

FIG. 4A2 is a detailed perspective view of the bifurcation section of the respiration sensing lead shown in FIG. 1;

FIG. 4A3 is a detailed perspective view of the contralateral distal body portion of the respiration sensing lead shown in FIG. 1;

FIG. 4A4 is a detailed perspective view of the ipsi-lateral distal body portion in the respiration sensing lead shown in FIG. 1;

FIG. 4B is a detailed perspective view of an alternative embodiment of the respiration sensing lead which may be used in the system shown in FIG. 1;

FIG. 4B1 is a detailed perspective view of the proximal connector assembly of the respiration sensing lead shown in FIG. 4B;

FIG. 4B2 is a detailed perspective view of the distal body portion of the respiration sensing lead shown in FIG. 4B;

FIG. 4C illustrates the implanted system shown in FIG. 1 with the respiration lead shown in FIG. 4A;

FIG. 4D illustrates the implanted system shown in FIG. 1 with the respiration lead shown in FIG. 4B;

FIG. 4E illustrates an alternative embodiment of the respiration sensing lead which may be used in the system shown in FIG. 1;

FIG. 4F illustrates an alternative embodiment of the respiration sensing lead containing a loop-back region. This lead may be used in the system shown in FIG. 1;

FIG. 4G illustrates an alternative embodiment of the respiration sensing lead which may be used in the system shown in FIG. 1;

FIG. 4H illustrates an alternative embodiment of the respiration sensing lead which may be used in the system shown in FIG. 1;

FIG. 5A shows front, side and top views of an implantable neurostimulator for use in the system shown in FIG. 1;

FIG. 5B is a schematic block diagram of electronic circuitry for use in the implantable neurostimulator shown in FIG. 5A;

FIGS. 6A, 6B, and 6C illustrate a bio-impedance signal, the corresponding physiological events, and stimulation delivery algorithms for use in the system shown in FIG. 1;

FIGS. 6D, 6E, 6F, 6G, and 6H illustrate various stimulation pulse configurations for the implantable neurostimulator shown in FIG. 1, as may be used for therapy or sleep titration, for example;

FIG. 6I (traces 1-8) shows various stimulation modes for the implantable neurostimulator shown in FIG. 1, as may be used for therapy or sleep titration, for example;

FIG. 6J shows a stimulation regimen called core hours for the implantable neurostimulator shown in FIG. 1, as may be used as a therapy mode;

FIG. 7A is a schematic illustration of the programmer system for use in the system shown in FIG. 1;

FIGS. 7B and 7C are schematic block diagrams of electronic circuitry for use in the programmer system for shown in FIG. 7A;

FIG. 8A is a schematic illustration of the therapy controller for use in the system shown in FIG. 1;

FIG. 8B is a schematic block diagram of electronic circuitry for use in the therapy controller shown in FIG. 8A;

FIG. 9 is a top view of a magnet for use in the system shown in FIG. 1;

FIG. 10 is a schematic illustration of an interface of the system shown in FIG. 1 and polysomnographic (PSG) equipment as may be used in a sleep study for therapy titration or therapy assessment, for example;

FIG. 11A is an anatomical illustration showing the incision sites and tunneling paths that may be used for implanting the internal components shown in FIG. 1;

FIG. 11B is a perspective view of a disassembled tunneling tool for use in tunneling the leads of the system shown in FIG. 1;

FIG. 11C is a detailed perspective view of the assembled tunneling tool shown in FIG. 11B, but with the cap removed to expose the distal connector for attaching to the lead carrier disposed on the proximal end of a lead;

FIG. 12A shows a flowchart of an idealized therapy process and the sub-processes that may be involved;

FIGS. 12B, 12C, and 12D show detailed flowcharts of idealized therapy sub-processes shown in FIG. 12A;

FIG. 13 (traces 1-8) illustrate various stimulation output modes of the implantable neurostimulator shown in FIG. 1;

FIG. 14 illustrates an example of the effect of stimulation on airflow; and

FIG. 15 illustrates a sleep wand, for wireless communication with the neurostimulator during sleep.

DETAILED DESCRIPTION OF EXEMPLARY EMBODIMENTS

The following detailed description should be read with reference to the drawings in which similar elements in different drawings are numbered the same. The drawings, which are not necessarily to scale, depict illustrative embodiments and are not intended to limit the scope of the invention.

Overall System

FIG. 1 schematically illustrates a hypoglossal nerve stimulation (HGNS) system 100 comprising internal components 1000 and external components 2000. The HGNS system 100 treats obstructive sleep apnea (OSA) by increasing neuromuscular activity to the genioglossus muscle via stimulation of the hypoglossal nerve (HGN) synchronous with inspiration to mitigate upper airway collapse during sleep. Stimulation is generated by an implantable neurostimulator (INS) 1100, synchronized with inspiration as measured by the respiration sensing lead (RSL) 1200 using bio-impedance, and delivered to the hypoglossal nerve by a

stimulation lead (STL) 1300. A programmer system 2100 and a therapy controller 2500 are wirelessly linked to the INS 1100. The programmer system 2100 includes a computer 2300, a programmer interface 2400, and a programmer head 2200. The programmer system 2100 is used by the physician to control and program the INS 1100 during surgery and therapy titration, and the therapy controller 2500 is used by the patient to control limited aspects of therapy delivery.

The implanted components 1000 of the HGNS system 100 include the INS 1100, STL 1300, and RSL 1200. The INS is designed to accommodate one STL 1300 and one RSL 1200. One STL 1300 may be used for unilateral implantation and unilateral hypoglossal nerve stimulation. Similarly, one RSL 1200 may be used for respiration detection. Alternative embodiments of the RSL 1200 are described below and may be substituted. Therefore, for purposes of illustration not limitation, the INS 1100 is shown with STL 1300 and a bifurcated RSL 1200.

The implanted components 1000 may be surgically implanted with the patient under general anesthesia. The INS 1100 may be implanted in a subcutaneous pocket inferior to the clavicle over the pectoralis fascia. The distal end of the STL 1300 (cuff 1350) may be implanted on the hypoglossal nerve or a branch of the hypoglossal nerve in the submandibular region, and the proximal end of the STL 1300 may be tunneled under the skin to the INS 1100. The RSL 1200 may be tunneled under the skin from the INS 1100 to the rib cage and placed on the costal margin. The INS 1100 detects respiration via the RSL 1200 using bio-impedance.

Stimulation Lead (STL)

FIG. 2 schematically illustrates the STL 1300 in more detail. The STL 1300 is designed to deliver the stimulation signal from the INS 1100 to the hypoglossal nerve and includes a proximal connector assembly 1310, a main tubular body 1330, and a distal cuff 1350. The main tubular body of the STL includes a sigmoid shaped section 1370 and a distal flexible transition section 1380 proximal of the cuff. The STL may have a nominal outside diameter of 0.062 inches to have minimal cosmetic impact, and a nominal overall length of 17.7 inches (45 cm) (including cuff) to extend from the infraclavicular region (INS) to the submandibular region (hypoglossal nerve) and to accommodate anatomical variation.

The main tubular body 1330 of the STL 1300 is designed to withstand gross neck movement as well as mandibular movement and hypoglossal nerve movement caused by talking, chewing, swallowing, etc. To survive in this high fatigue environment, the main tubular body 1330 incorporates a highly compliant silicone jacket in the form of a sigmoid, and two conductors 1390 (one for cathode electrodes, one for anode electrodes) each comprising ETFE insulated MP35N multifilament cable disposed inside the jacket in the form of a bi-filar coil (not visible). This design provides high fatigue resistance and three-dimensional flexibility (bending and elongation).

The proximal connector assembly 1310 is designed to provide a reliable mechanical and electrical connection of the STL 1300 to the INS 1100. It has a number of strain relief elements that enable it to withstand handling during insertion and removal from the INS 1100, as well as adverse conditions encountered when implanted. The connector assembly 1310 includes two in-line stainless steel ring contacts (one for each conductor 1390) and two silicone ring seals. STL proximal connector contacts 1310 may have a nominal outside diameter of about 0.122 inches. Set screws

in the header of the INS 1100 bear down on the contacts, and together with the ring seals, provide a sealed mechanical and electrical connection to the INS 1100. As an alternative, wound coil spring contacts may provide mechanical and electrical connections.

More detailed views of the cuff 1350 are shown in FIGS. 3A and 3B, wherein FIG. 3A schematically illustrates the cuff 1350 in isometric view, and FIG. 3B schematically illustrates the cuff 1350 in cross-sectional view. The cuff 1350 has a hinged oval-shaped silicone body (collectively 1352 and 1354) to define an oval lumen 1355 that provides secure and gentle retention around the hypoglossal nerve. The cuff 1350 may be designed to fit the nerve very closely to minimize tissue growth between the electrode and nerve. The cuff is designed to be self-sizing such that different nerve diameters may be accommodated safely. The self-sizing can safely adjust to larger sizes if swelling occurs. This reduces the likelihood of nerved damage caused by unsafe pressures. Thus, the cuff may be available in two sizes to accommodate nerves of different diameter: a small size to accommodate nerves having a diameter of up to about 2.5-3.0 mm, and a large size to accommodate nerves having a diameter of up to 3.0-4.0 mm. At 3.0 mm nerve diameter, either size cuff will fit the nerve with minimal open space for tissue in-growth. Using a large cuff on a 2.5 mm nerve allows clearance between the nerve and electrode which promotes capsule formation between the cuff and nerve. This may cause an increase in capture threshold but will not affect safety. Conversely, a small cuff placed on a large nerve minimizes electrode coverage around the nerve and may fall off with swelling. The short side 1352 (e.g., 4.0 mm long) of the cuff body fits between nerve branches and connective tissue on the deep side of the nerve, thereby minimizing nerve dissection. The long side 1354 (e.g., 10.0 mm long) of the cuff body rests on the superficial side of the nerve (where few branches exist) and is connected to the transition section 1380 of the main lead body 1330.

A silicone strap 1356 is connected to and extends from the short side 1352 of the cuff body. A silicone top plate comprising an integral base portion 1359 and loop 1358 is attached to and covers the exterior surface of the long side 1354 of the cuff body. The strap 1356 freely slides through the loop 1358, and wraps around the long side 1354 of the cuff body. The strap 1356 is removed from the loop 1358 for placement of the cuff 1350 around the nerve and reinserted into the loop 1358 to hold the cuff 1350 on the nerve. A mark may be disposed on the strap 1356 of the small size cuff to indicate that the cuff is too small and that a larger size cuff should be used if the mark does not pass through the loop 1358. The cuff body readily expands along a hinge line 1353 (defined at the junction of the short side 1352 to the long side 1354) as well as other portions of the cuff 1350 structure. Expansion of the cuff body accommodates nerves of different diameters and nerve swelling after implantation, while the strap 1356 remains in the loop 1358 to retain the cuff 1350 on the nerve. In the event of excess nerve swelling (e.g., >50% increase in nerve diameter) or traction from the lead 1300 (e.g., as may accidentally occur during implantation), the strap 1356 pulls out of the loop 1358 and releases the cuff 1350 from the nerve to minimize the potential for nerve damage.

The cuff body carries four platinum-iridium electrodes 1360 (e.g., 2.0 mm² exposed area each for small cuff, 3.0 mm² exposed area each for large cuff), with one cathode electrode 1360 on the short side 1352, another cathode electrode 1360 (not visible) diametrically opposed on the long side 1354, and two anode electrodes 1360 guarding the

cathode electrode 1360 on the long side 1354. This guarded dual cathode arrangement provides a more uniform electrical field throughout the cross-section of the nerve while minimizing electrical field outside of the cuff. One conductor 1390 may be connected to the cathode electrode 1360 on the long side, to which the other cathode electrode 1360 on the short side is connected by a jumper wire. Similarly, the other conductor 1390 may be connected to the distal anode electrode 1360, to which the proximal anode electrode 1360 is connected by jumper wire. With this arrangement, the cathode electrodes are commonly connected to one conductor 1390 and the anode electrodes are commonly connected to the other conductor 1390.

With the exception of the metal electrode contacts in the cuff, all external surfaces of the STL 1300 exposed to the body when implanted may comprise implantable grade polymers selected from the following: silicone, and fully cured silicone adhesive. The metal electrode contacts in the cuff may comprise implantable grade platinum-iridium and are secured to the silicone cuff body with silicone adhesive, for example.

Respiration Sensing Lead (RSL)

FIGS. 4A-4G schematically illustrates the respiration sensing lead (RSL) 1200 in more detail. The respiration sensing lead 1200 is designed to measure bio-impedance and includes a proximal portion with a proximal connector assembly 1210, a proximal tubular body 1220 ending in a bifurcation section 1280, and ipsi-lateral and contra-lateral distal portions extending from the bifurcation section. Each distal portion may include a tubular body 1220, a proximal sigmoid section 1230, a distal sigmoid section 1240, one or more current injection ring electrodes 1250, one or more voltage sensing ring electrodes 1260, anchor tabs 1270, and a suture hole 1290 in the most distal ring electrodes. Alternatively, the ring electrodes 1250 and 1260 may be dual-function, such that each electrode may function as either a current emitting electrode or voltage sensing electrode. The ipsi-lateral distal portion may contain three ring electrodes, the most distal being a current emitting electrode 1250 and containing a suture hole 1290, and the other two electrodes being voltage sensing electrodes 1260. The contra-lateral distal portion may contain two ring electrodes, the distal being a current emitting electrode 1250 and containing a suture hole 1290, and the proximal a voltage sensing electrodes. It may be advantageous to have the suture holes in the most distal ring electrodes since no wires pass through this point and because this provides a robust anchor point for the electrode to be sutured on the costal margin muscle fascia. The RSL 1200 may have a nominal outside diameter of about 0.072 inches to have minimal cosmetic impact. The RSL proximal connector contacts 1210 may have a nominal outside diameter of about 0.122 inches (same as the STL proximal connector contacts 1310). The distal ring electrodes (here, current emitting electrodes 1250), may also have a nominal outside diameter of 0.122 inches. This uniformity in diameters may be advantageous, allowing the same lead carrier 3100 to place both STL 1300 and RSL 1200 leads for tunneling.

The distance from the tip of the proximal connector 1210 to the bifurcation section 1280 may have an overall length of 8.9 inches (22.5 cm). The distance from the bifurcation section 1280 to the ipsi-lateral proximal anchor tab 1270 may be 9.6 inches (24.4 cm) unstretched and 12.2 inches (31 cm) stretched. The distance from the bifurcation section 1280 to the contra-lateral proximal anchor tab 1270 may be 13.5 inches (34.3 cm) unstretched and 16.1 inches (41 cm) stretched. The distance from the proximal anchor tab 1270

to the distal suture hole **1290** may be 2.8 inches (7 cm) unstretched and 3.1 inches (8 cm) stretched on both the contra-lateral and ipsi-lateral distal portions. The RSL **1200** may extend from the infraclavicular region (where the INS **1100** is implanted) to the ipsi-lateral and contra-lateral thorax where the RSL **1200** may be implanted to accommodate anatomical variation.

The bifurcated RSL **1200** design enables one RSL **1200** to sense bio-impedance on the contra-lateral and ipsi-lateral sides of the thorax. Two RSLs **1200**, one on each side of the patient's chest, may also achieve this. The bifurcated design achieves this result while reducing the number of implanted components and reducing volume of the INS header **1110** since only one RSL port **1112** is required.

The main tubular lead body **1220** of the RSL **1200** is designed to withstand thoracic movement due to flexion, extension, rotation and breathing. To withstand this environment, the main tubular body **1220** may include a flexible silicone jacket formed such that each distal end has two sigmoid sections, **1230** and **1240**, and conductors comprising small diameter ETFE insulated MP35NLT cables (not visible) disposed inside the jacket. An injection molded Y-fitting (yoke) connects the proximal portion of the RSL **1200** to the distal portions, creating the bifurcation section **1280**. Conductors, here five, are continuously fed from the connector assembly through the proximal tubing body **1220** and proximal portion of the Y-fitting. Three of these conductors continue through the ipsi-lateral distal portion of the Y-fitting to the ipsi-lateral distal tubing body of the RSL. The other two conductors continue through the contra-lateral distal portion of the Y-fitting and to the contra-lateral distal tubing body of the RSL. The tubing bodies may be adhesively bonded or molded to the Y-fitting. The number of conductors may equal the number of contacts in the INS header **1112**, here five. Two of the conductors, one on each side, may connect proximally to current emitting header contacts, (e.g., **R1** and **L1**), and terminate distally in current emitting electrodes **1250**. Three of the conductors may connect proximally to voltage sensing header contacts (e.g., **R2**, **R3**, and **L3**) and terminate distally in voltage sensing electrodes. As mentioned previously, dual-function electrodes may enable any electrode (ring electrode **1250** or **1260**) to emit current or sense voltage. This switching may occur via components on the INS circuit board **1130**. Alternatively, a bridge may be formed joining two contacts in the proximal connector assembly such that the corresponding electrode may function as either a current emitting electrode **1250** or voltage sensing electrode **1260**. Dual-function electrodes enable more vectors in an implanted region without additional electrodes.

The proximal sigmoid section **1230** isolates movement of the INS **1100** from the electrodes **1250** and **1260**, and accommodates anatomic variations in thoracic length. The distal sigmoid section **1240** allows adjustment in the distance between electrodes **1250** and **1260**, and reduces strain applied between the anchor tabs **1270**, which may be secured with sutures to the underlying fascia when implanted. The proximal sigmoid **1230** section may have 5 wavelengths with an outside peak-to-peak dimension of approximately 0.84 inches (2.1 cm) and an overall length of 7.0 inches (17.8 cm). The distal sigmoid **1240** section may have half a wavelength with a center-to-center peak-to-peak dimension of approximately 0.43 inches (2.1 cm) and an overall length of 0.869 inches (2.2 cm).

The two distal portions' electrodes **1250** and **1260** may comprise five electrodes total, and each may comprise MP35N rings having an exposed surface area. The distal

electrode containing a suture hole **1290** may have an exposed surface area of 73.8 mm² including the suture hole **1290**, and 66.4 mm² not including the suture hole **1290**. The proximal electrode containing an anchor tab **1270** may have an exposed surface area of 30.5 mm² and the electrode without an anchor tab may have an exposed surface area of 32.0 mm². Tubular strain relief segments may be disposed on the lead body on either side of electrode **1250** or **1260**. Where the strain relief segments are adjacent to each other, a gap may be provided there between the strain relief segments or the segments may abut one another to avoid a stress concentration point. Strain reliefs may also be disposed on each end of the electrodes **1250** or **1260** to avoid stress concentration points. The anchor tab **1270** may be disposed over an electrode leaving the proximal and distal extremities of the electrode exposed.

At any given time, the INS **1100** detects impedance along a vector, with each end of the vector defined by a current delivery electrode **1250** and a voltage sensing electrode **1260**. In each vector, a small excitation current is delivered between the two current emitting electrodes **1250**, and the corresponding change in voltage is measured by the two voltage sensing electrodes **1260**. The INS housing **1120** may also act as a current emitting and/or voltage sensing electrode, or contain smaller current emitting and/or voltage sensing electrodes on its surface. Changes in impedance are calculated by dividing the change in voltage by the excitation current, which correspond to movement of the diaphragm, lung, and other tissues to produce a signal indicative of respiratory activity.

The proximal connector assembly **1210** of the RSL **1200** is designed to provide a reliable mechanical and electrical connection of the RSL **1200** to the INS **1100**. It has a number of strain relief elements that enable it to withstand handling during insertion and removal from the INS **1100**, as well as adverse conditions encountered when implanted. The connector assembly **1210** may include five in-line stainless steel ring contacts (one for each conductor) and five silicone ring seals. Set screws in the header of the INS **1100** bear down on the contacts, and together with ring seals, provide a sealed mechanical and electrical connection to the INS **1100**. Ring seals may be part of the RSL **1200** or the INS header **1110**. With the exception of the distal electrodes, all external surfaces of the RSL **1200** exposed to the body when implanted may comprise implantable grade polymers selected from the following: silicone, and fully cured silicone adhesive. The distal electrodes may comprise implantable grade MP35N and are sealed to the lead body with silicone adhesive, for example.

A wide variety of respiration sensing lead designs may be employed to provide at least one bio-impedance vector (current injection electrode pair and voltage sensing electrode pair) from a point along the costal margin to a point along the opposite (trans-lateral) costal margin, to a point along the same side (ipsi-lateral) costal margin, or to a point in the infraclavicular region, as seen in FIG. 4C. For example, an alternative embodiment of the RSL **1200** is shown in FIG. 4B, wherein the bifurcation section **1280** and contra-lateral distal portion are eliminated. In this three electrode straight RSL **1200** embodiment, there is one current emitting ring electrode **1250** and two voltage sensing ring electrodes **1260**. The lead body may contain three conductors. The connector assembly **1210** may include three in-line stainless steel ring contacts (one for each conductor) and three silicone ring seals. The RSL may have an overall length of 21.2 inches (53.9 cm). The distance from the proximal tip of the proximal connector assembly **1210** to the

first sigmoid may be 9.5 inches (24.1 cm). The proximal sigmoid **1230** section may have 5 wavelengths with an outside peak-to-peak dimension of approximately 0.84 inches (2.1 cm) and an overall length of 7.0 inches (17.8 cm). The distal sigmoid **1240** section may have a $\frac{1}{2}$ wavelength with a center-to-center peak-to-peak dimension of approximately 0.43 inches (2.1 cm) and a length of 0.869 inches (2.2 cm). The RSL **1200** may be implanted ipsi-laterally on the ipsi-lateral costal margin, a less invasive surgery, while maintaining vectors from the ipsi-lateral costal margin to the infraclavicular region, see FIG. 4D.

Further alternative embodiments are illustrated in FIGS. 4E, 4F, 4G, and 4H, wherein the RSL **1200** may contain four electrodes, one or more of which can function as either a current emitting electrode **1250** or voltage sensing electrode **1260**, as described previously. Here, this is achieved by exposing the conductor of the bi-functional electrode to two contacts (one voltage sensing, one current emitting) in the INS header **1110**, and selecting only one contact for sensing. Alternatively, this functionality may be built into the INS circuit board **1130**. These embodiments of the RSL **1200** may be implanted ipsi-laterally (e.g. on the right costal margin), which is a less invasive surgery, while maintaining vectors from the ipsi-lateral costal margin to the infraclavicular region.

FIG. 4E illustrates a straight four electrode RSL **1200**. This is similar in design to the RSL **1200** of FIG. 4B, wherein there are a first, second, third, and fourth electrodes, from proximal to distal.

FIG. 4F illustrates a four electrode RSL **1200** with a loop back region **1255**. This differs from the above embodiments in that there is an extra half sigmoid in the proximal sigmoid section **1230** after which the lead body enters the loop back region **1255**. Here, the lead body runs in the medial direction, then loops back in the lateral direction. The loop back region **1255** may act as a strain relief and allow the medial anchor tab **1270** to be sutured at the intersection of the two tunneling paths (from INS incision to medial incision, and between two RSL incisions). This may allow the RSL **1200** to lie in an unbiased preferred configuration along the costal margin. Here again, the first and third most distal electrodes are current emitting, and the second, third, and fourth most distal electrodes are voltage sensing.

FIG. 4G illustrates a four electrode RSL **1200** with a bifurcation section **1280** created by a T-fitting. An injection molded T-fitting connects the proximal portion of the RSL **1200** to the distal portions, creating the bifurcation section **1280**. Conductors, here four, are continuously fed from the connector assembly through the proximal tubing body **1220** and proximal portion of T-fitting. Two of these conductors continue through the proximal distal portion of the T-fitting to the proximal distal tubing body of the RSL. The other two conductors continue through the medial distal portion of the T-fitting and to the medial distal tubing body of the RSL. The tubing bodies may be adhesively bonded or molded to the T-fitting. The anchor tab **1270** may be adhesively bonded to the bifurcation section **1280**. Again, this may allow the RSL **1200** to lie in an unbiased preferred configuration along the costal margin. In addition, the T-fitting may act as a strain relief. Both medial and lateral distal electrodes may contain suture holes **1290**.

FIG. 4H illustrates an alternative embodiment of the RSL **1200**, wherein the RSL **1200** has an overall L-shape. In this embodiment, there may be four ring electrodes, numbered one through four from most proximal to furthest distal. The first and fourth electrodes may be current emitting electrodes **1250**. The second and third electrodes may be voltage

sensing electrodes **1260**. The lead body may contain four conductors. The connector assembly **1210** may include four in-line stainless steel ring contacts (one for each conductor) and four silicone ring seals. The proximal portion of the RSL **1200** (including the proximal connector and proximal sigmoid) may have an overall length of 17.0 inches (43.2 cm). The distance from the proximal tip of the proximal connector assembly **1210** to the first sigmoid may be 11.1 inches (28.1 cm). The proximal sigmoid **1230** section may have 4.5 wavelengths, each wavelength 1.25 inches (3.2 cm), and with an outside peak-to-peak dimension of approximately 0.84 inches (2.1 cm). The distal portion of the RSL **1200** (from the distal end of the proximal sigmoid **1230** to the distal suture hole **1290**) may have an overall length of 4.9 inches (12.5 cm). The length from the distal end of the proximal sigmoid **1230** to the proximal end of the distal sigmoid **1240** may be 2.2 inches (5.7 cm). The length from the distal end of the distal sigmoid **1240** to the distal suture hole **1290** may be 1.8 inches (4.6 cm). The distal sigmoid **1240** section may have a center-to-center peak-to-peak dimension of approximately 0.92 inches (2.3 cm). The RSL **1200** may be implanted ipsi-laterally on the ipsi-lateral costal margin, a less invasive surgery, while maintaining vectors from the ipsi-lateral costal margin to the infraclavicular region.

Implantable Neurostimulator (INS)

FIG. 5A schematically illustrates the INS **1100** in more detail, including a front view, a top view and a side view. The INS **1100** is similar in certain aspects to commercially available implantable pulse generators and implantable neurostimulators, which may be obtained from suitable manufacturers such as CCC Medical Devices (Montevideo, Uruguay). The INS **1100** generally includes a header **1110** for connection of the STL **1300** and RSLs **1200**, and a hermetically sealed housing **1120** for containing the associated electronics **1130**, a battery **1140** (e.g., Greatbatch 9086), and an accelerometer **1150**. The INS **1100** may contain an oxygen sensor (e.g., SaO_2 , SpO_2 , ion, etc.). Alternatively, the oxygen sensor may be incorporated in a lead with connection to the INS **1100**.

The electronic circuitry **1130** contained in the INS **1100** enables telemetry communication with the programmer system **2100** and therapy controller **2500**, detection of respiration via the RSL **1200**, determination of the start time and duration of a stimulation signal, and delivery of a controlled electrical stimulation signal (pulse train) via the STL **1300**. The INS **1100** also records therapy history data (device settings, status, measured data, device use, respiration data, stimulation delivery data, statistics based on measured signals, etc.).

The header **1110** may comprise epoxy that is hermetically sealed to the housing **1120**. The housing **1120** may comprise titanium. As mentioned in the context of respiration sensing, the housing **1120** may be used as an electrode for bio-impedance respiration measurement. Similarly, electrodes **1360** may be used as an electrode for bio-impedance respiration measurement. For example, the housing **1120** may comprise a combination current emitting and voltage sensing electrode for respiration detection. Alternatively, separate electrodes may be included in the header of the device from which to sense or stimulate.

The header **1110** includes two ports: one RSL port **1112** (labeled "sense") for receiving the proximal connector of the RSL **1200** and one STL port **1114** (labeled "stim") for receiving the proximal connector of the STL **1300**. The port configured to receive a STL **1300** includes two set screws (labeled "-" for cathode and "+" for anode) with associated

set screw blocks and seals for mechanical and electrical connection to corresponding contacts on the proximal connector **1310** of the STL **1300**. Similarly, the port that is configured to receive a RSL **1200** includes five set screws (two labeled **R1** and **L1** for current emitting electrodes and three labeled **R2**, **R3**, and **L3**, for voltage sensing electrodes) with associated set screw blocks and seals for mechanical and electrical connection to corresponding contacts on the proximal connector **1210** of the RSL **1200**. Seals are located between electrical contacts as well as between the distal-most electrical contact and the remainder of the proximal connector assembly **1210**. These seals electrically isolate each contact.

Alternatively, wound coil spring contacts may provide electrical connections between the INS header **1110** and the proximal connector assemblies **1210** and **1310**. Typically, one electrical connection is still achieved with a set screw which also serves to hold the connector assembly in place. This embodiment provides a sealed mechanical and electrical connection of the RSL **1200** and STL **1300** to the INS **1100**. An example of this technology is Bal Seal's Canted Coil™ Spring Technology.

The header **1110** further includes two suture holes **1116** for securing the INS **1100** to subcutaneous tissue such as muscle fascia using sutures when implanted in a subcutaneous pocket. As shown, component values and component configurations are given by way of example, not limitation.

The INS **1100** generates the stimulation output for delivery to the hypoglossal nerve by way of the STL **1300**. For this purpose, the INS **1100** has a bipolar stimulation output channel corresponding to the STL port **1114**, with the channel providing a pulse train of bi-phasic constant current pulses with a frequency range of 20 to 50 Hz, a pulse width range of 30 to 215 μ s, an amplitude range of 0.4 to 5.0 mA, and a stimulation duty cycle range of 41%-69%, by way of example, not limitation.

The INS **1100** also generates the excitation signal and measures voltage by way of the RSL **1200** for bio-impedance respiration detection. For this purpose, the INS **1100** also has two respiration sensing channels for simultaneous acquisition of bio-impedance sensing on different vectors. This may be achieved by sequential or alternating sampling of different vectors. The INS **1100** measures bio-impedance via the RSL port **1112**, with each channel providing a small excitation current ("I") and measuring voltage ("V"). The excitation signal may comprise a 10 Hz biphasic constant current pulse, with the positive and negative phases of each biphasic pulse having amplitude of 450 μ A, duration of 80 μ s, and charge of 36 nC. Current ("I") may be fixed, allowing voltage ("V") to be a relative measure of impedance ("Z"), which corresponds to movement of the diaphragm, lung, and other structures to produce a signal indicative of respiratory activity.

With reference to FIG. 5B, a block diagram of an example of the INS circuit **1130** is shown schematically. The INS circuit **1130** utilizes a microprocessor to control telemetry communications with the programmer system **2100**, operating the sensing circuits to monitor respiration via the RSL **1200**, controlling the delivery of output stimuli via the STL **1300**, monitoring the accelerometer, magnetically sensitive reed switch and the real-time clock. The microprocessor contains built-in support circuits (RAM, flash memory, analog to digital (A/D) converter, timers, serial ports and digital IO) used to interface with the rest of the INS circuit **1130**, including the accelerometer **1150**. Two microprocessors communicating via a serial link may be used instead of one microprocessor, with the first microprocessor for telem-

etry communications, monitoring the accelerometer, magnetically sensitive reed switch and the real-time clock; and the second microprocessor for operating the sensing circuits and controlling the delivery of output stimuli. Alternatively, a single microprocessor could perform these functions.

The telemetry interface circuits consist of a tuned telemetry coil circuit and a telemetry driver/receiver circuit to allow pulse encoded communication between the external programmer system **2100** and the microprocessor. As an alternative to telemetry coils and an inductive link, RF antennae with associated circuitry may be used to establish a RF link to provide for arms-length telemetry. The reed switch provides a means for the INS **1100** to be controlled by using a magnet placed in close proximity thereto. The real-time clock provides the basic time base (768 Hz) for the INS circuit **1130** as well as a clock (year, day, hour, minute, second) which can be used to control the scheduled delivery of therapy. The clock is also used to time-stamp information about the operation of the system that is recorded on a nightly basis.

The respiratory sensing circuit is comprised of two main parts: the excitation current source (output) and the voltage sensing circuit (input). As will be described in more detail hereinafter, respiration is detected via the RSL **1200** using a 3 or 4-wire impedance measurement circuit. In a 4-wire measurement, an excitation current is driven through a pair of electrodes, and the resulting voltage is measured on a separate pair of electrodes. The electrode switching circuits allow the INS **1100** to monitor one of several different vectors from the RSL electrodes **1250** and **1260**. As mentioned previously, each physical electrode may function as a current emitting electrode **1250** or a voltage sensing electrode **1260**, depending on the programmable vector configuration. In one embodiment of a 3-wire measurement, the INS housing **1120** may be used as both an excitation and sensing electrode. The excitation current circuit delivers biphasic pulses of low level (450 μ A) current to the selected electrode pair every 100 ms during sensing. The voltage sensing amplifier circuit synchronously monitors the voltage produced by the excitation current on the selected electrode pair. The resulting output signal is proportional to the respiratory impedance (0.07 Ω to 10 Ω) and is applied to the A/D circuit in the microprocessor for digitization and analysis.

The stimulation output circuits deliver bursts of biphasic stimulation pulses to the STL **1300**. These bursts may be synchronized to the sensed respiratory waveform to deliver stimulation and thus airway opening at the appropriate time. The stimulation output circuits include an electrode switching network, a current source circuit, and an output power supply. The electrode switching network also allows for a charge balancing cycle following each stimulation pulse during which the outputs are connected together with no applied output pulse. The timing and polarity of the pulse delivery is provided by control outputs of the microprocessor. The microprocessor selects the amplitude (e.g., 0.4 mA to 5 mA) of the output current from the current source circuit which is applied through the switching network. The output power supply converts battery voltage to a higher voltage (e.g., 5V to 14V) which is sufficient to provide the selected current into the load impedance of the STL **1300**. The microprocessor measures the voltage output from the electrode switching network resulting from the delivered current and the load impedance. The microprocessor divides the output voltage by the output current resulting in a measure of the load impedance (400 Ω to 2700 Ω) which can be an indicator of integrity of the STL **1300**.

The INS 1100 (or lead connected to the INS 1100) may contain an oxygen sensor to monitor oxygen levels, for example during a therapy session. This may be used to monitor efficacy as well to set stimulation settings during a therapy session. For example, the INS 1100 may be programmed to increase stimulation when oxygen de-saturations are detected at a programmable threshold rate and/or severity. In addition, the INS 1100 may turn stimulation on once de-saturations are detected, wherein thresholds of rate and severity are programmable. Desaturations may act to indicate the sleep state or wakefulness. In a similar manner, electroencephalogram (EEG) may be used to monitor nerve activity, which may also be indicative of sleep state and/or wakefulness. The INS 1100 may use the indication of sleep state or wakefulness to change stimulation settings. For example, stimulation may be increased when the patient is in N3 or REM sleep. In addition, stimulation level may be decreased or turned off during stage N1, N2, or wakefulness.

The INS 1100 circuitry may contain a three-axis accelerometer 1150 that can be used to determine the patient's body position (supine, prone, upright, left, or right side) and/or detect motion events (wakefulness). These data may be used to change stimulation settings or inhibit output. The INS 1100 may be programmed to increase stimulation intensity when the patient is in specific body positions (e.g., supine, a more challenging position). The INS 1100 may segregate recorded therapy statistics (e.g., cycling detector events, oxygen desaturations) with respect to body position. For example, a patient's cycling detector may record very few events in the lateral position and many events in the supine position, indicative of the patient being treated in the lateral position.

With reference to FIG. 6A, the bio-impedance respiration signal ("Z"), which is generated by dividing the change in measured voltage ("V") by the excitation current ("I"), tracks with diaphragm movement (DM) over time and therefore is a good measure of respiratory activity, and may be used to measure respiratory effort, respiratory rate, respiratory (tidal) volume, minute volume, etc. If the excitation current (I) is constant or assumed constant, then the bio-impedance (Z) is proportional to the measured voltage (V), and thus the voltage (V) may be used as a surrogate for bio-impedance (Z), thereby eliminating the division step. As used in this context, diaphragm movement includes movements and shape changes of the diaphragm and adjacent tissue that occur during normal breathing and during obstructed breathing. The bio-impedance waveform may be filtered to reduce noise and eliminate cardiac artifact, clarifying positive and negative peak occurrence. The signal may be filtered using a first order low pass filter. Alternatively, a higher order curve fit approach could be utilized to filter the signal. The (positive or negative) peak (P) of the impedance signal (Z) corresponds to the end of the inspiratory phase and the beginning of the expiratory phase. If the signal is normal (as shown), the positive peak is used; and if the signal is inverted, the negative peak is used. The beginning of the inspiratory phase occurs somewhere between the peaks and may not be readily discernable. Thus, the impedance signal provides a reliable fiducial (P) for end-inspiration and begin-expiration (also called expiratory onset), but may not provide a readily discernable fiducial for begin-inspiration (also called inspiratory onset). Therefore, algorithms described herein do not rely on begin-inspiration (or inspiratory onset) to determine the start of stimulation bursts as proposed in the prior art, but rather use a more readily discernable fiducial (P) corresponding to begin-expiration

(or expiratory onset) in a predictive algorithm as described below. Other non-predictive (e.g., triggered) algorithms are described elsewhere herein.

Gross body motion is often indicative of patient wakefulness and may change the bio-impedance signal (Z). A motion event may be detected, for example, by assessing variability in the bio-impedance peak-to-peak signal strength (P-P). Different thresholds of sensitivity may be utilized such that minor movements are not grouped with motion events. When a motion event is determined, stimulation may be turned off or turned down until motion stops or for a programmable duration of time. The frequency and duration of these motion events may be recorded in device history. The accelerometer 1150 could be utilized in a similar fashion to detect and record motion events

Waxing and waning of the bio-impedance signal (Z) is often indicative of apneas or hypopneas. Generally referred to as cycling, this pattern may be detected, for example, by assessing trends of increasing and decreasing average P-P amplitude values. Different thresholds of sensitivity may be utilized such that minor changes in P-P values are not declared cycling events. When cycling is detected, stimulation parameters may be initiated or changed (e.g., increased intensity, increased duty cycle, etc.) to improve therapy. The frequency and duration of these cyclic breathing patterns may be recorded in therapy history. These values may be used as an indicator of how well the patient is being treated, providing an estimate of AHI.

The INS 1100 may be programmed to change stimulation level between therapy sessions, days, or other programmable value. The stimulation level may be recorded alongside therapy session data, for example cycling rate (via the cycling detector), oxygen desaturation frequency and severity, stimulation time, variations in respiratory rate, variations in respiratory prediction, etc.

In people without OSA, inspiration is typically 25-50% of the respiratory cycle, with variations in respiration rate being common. Variations may cause actual inspiration to differ from predicted inspiration. The hypoglossal nerve usually activates approximately 300 ms before inspiration and remains active for the entire inspiratory phase. To mimic this natural physiology, it is desirable to deliver stimulation to the hypoglossal nerve during the inspiratory phase plus a brief pre-inspiratory period of about 300 ms. To maximize stimulation coverage of actual inspiration, it may be advantageous to account for this variability by centering stimulation on the predicted inspiration. As mentioned previously, there are reliable fiducials for the beginning of the expiratory phase (peak P) which may be used to deliver stimulation to cover the inspiratory phase plus brief pre and/or post-inspiratory periods.

Accordingly, an algorithm is used to predict respiratory period and determine the start of the stimulation burst. The predictive algorithm is contained in software and executed by a microprocessor resident in the INS circuitry 1130, thus enabling the INS 1100 to generate stimulation synchronous with inspiration. One example of a prediction algorithm uses the respiratory period of previous breaths to predict the respiratory period of each subsequent breath. In this algorithm, a respiratory period is determined by calculating the time between peaks in the bio-impedance signal (Z). If the actual respiratory period is different from the predicted respiratory period, then the subsequent predicted respiratory period is resynchronized and updated to equal the actual period, up to a programmable value (e.g., 300 ms). If the

difference in respiratory period exceeds the programmable value, then the predicted respiratory period is incremented or decremented by this value.

One example of a predictive algorithm is illustrated in FIG. 6B. In this example, the stimulation period is centered about a percentage (e.g., 75%) of the predictive respiratory period. The predictive algorithm uses historical peak data (i.e., begin-expiration data) to predict the time to the next peak, which is equivalent to the predicted respiratory period. The stimulation period is centered at 75%, for example, of the predicted respiratory time period. Thus, the time to start a stimulation burst is calculated by predicting the time to the next peak, adding 75% of that predicted time to the last peak, and subtracting $\frac{1}{2}$ of the stimulation period (stimulation start time=time of last peak+75% of predicted time to next peak- $\frac{1}{2}$ stimulation period). A phase adjustment parameter (range: +/-1000 ms, for example) permits the stimulation period to be biased early or late.

A feature common to the predictive algorithms is illustrated in FIG. 6C. This feature provides a sequence of predicted respiratory periods in case the respiration impedance signal ("Z") is temporarily lost (e.g., due to change in respiratory effort). Until a subsequent respiratory peak is detected, stimulation parameters which are based on the measured respiratory period (e.g., stimulation period) are unchanged. Thus, stimulation timing remains synchronous to the last detected peak.

The stimulation duty cycle may vary to meet efficacy and safety requirements. Generally, the stimulation duty cycle is used to determine the stimulation period as a percentage of the predicted respiratory period (stimulation period=duty cycle \times predicted respiratory period). After a stimulation burst (pulse train) is started, stimulation continues until the end of the stimulation burst as set by the stimulation duty cycle, or until the next actual peak is detected, whichever occurs first. Alternatively, the feature of terminating a stimulation period when an actual peak is detected may be turned off.

The stimulation duty cycle may be fixed or adaptive. In the fixed mode, the stimulation duty cycle is set using to programmer system 2100 to a fixed percentage value. This fixed value may be increased when the respiratory signal is lost, increasing the likelihood of aligning with actual inspiration. In adaptive mode, the duty cycle is allowed to vary as a function of a characteristic of respiration. For example, the adaptive duty cycle may increase when prediction is less accurate (higher variability in respiration rate) or when the respiratory signal is lost. Thus, in some instances, the stimulation duty cycle may run above normal (e.g., above 50% to 60%) to achieve a better likelihood of covering the inspiratory phase. Because above normal stimulation duty cycle may result in nerve and/or muscle fatigue if prolonged, it may be desirable to offset above-normal stimulation periods with below-normal stimulation periods to result in a net normal duty cycle. Thus, when the prediction is highly accurate (stable respiration rate), the stimulation duty cycle may be reduced.

The following stimulation duty cycle parameters are given by way of example, not limitation. In fixed mode, the maximum stimulation duty cycle may be set from 41% to 69% in 3% increments, and the default setting may be 50%. In adaptive mode, the stimulation duty cycle for a respiratory period may vary from 31% to 69% in 3% increments, and the maximum running average may be set to 53%. As mentioned above, the adaptive mode allows the duty cycle to decrease when respiratory period is stable and increase with respiratory period variability, for example, and the

stimulation duty cycle may run in excess of 53% for a limited period of time, but those periods are proportionally offset by periods where the stimulation duty cycle runs less than 53% (e.g., according to an exponentially weighted moving average). For example, an adaptive duty cycle set to 69% would run at that level for no longer than 5 to 7 minutes before being offset by a lower stimulation duty cycle at 47% to result in a running average of 53%. This equation is approximate and may vary slightly depending on the averaging technique used. Other offset methods may be used as an alternative.

The stimulation duty cycle may be nominally 50%. A duty cycle limiter may be enabled such that it prevents the device from exceeding a programmable long term average stimulation duty cycle threshold (e.g., 53%). Long term average duty cycle may be calculated using a first order filter of duty cycle measured over a fixed time period (e.g., 6 seconds), with a programmable filter time constant (e.g., each iterative calculation is given a weighting of $\frac{1}{2}$). If the long term average duty cycle reaches the programmable threshold, then stimulation duty cycle is decreased to a programmable value, (e.g., 44%) until the long term average drops below the nominal value (here, 50%), at which time the nominal duty cycle is restored. This safety mechanism may prevent nerve and muscle fatigue.

The INS 1100 may deliver stimulation as a train of pulses with constant pulse width and amplitude at a set frequency for a duration limited by duty cycle. This train of pulses may be described as a pulse train envelope and is illustrated in FIG. 6D. The envelope describes a series of biphasic pulses delivered consecutively during a stimulation burst. When the stimulation level of the positive phase of each biphasic pulse is uniform, this level is the level of the stimulation burst. The INS 1100 may also deliver stimulation in pulse train envelopes wherein the pulses are non-uniform (e.g., pulses may have different amplitudes).

The muscle(s) activated by the stimulation may not require the full stimulation intensity for the duration of the stimulation in order to maintain muscle contraction. Accordingly, the INS 1100 may be programmed to deliver a basic retention intensity pulse configuration, defined as a pulse train envelope wherein each pulse's intensity (e.g., amplitude) is less than or equal to the previous pulse's intensity, (e.g., a two second pulse wherein the first 1000 ms is at 2 mA and the subsequent 1000 ms is at 1.7 mA). This pulse configuration is illustrated in FIG. 6E. This allows the muscle to activate to a level and then remain in that position with a less intense stimulation. This may be more comfortable and allow the patient to fall asleep more easily with the stimulation on, be less likely to cause arousal from sleep, and/or reduce the possibility of muscle/nerve fatigue. Alternatively, the pulse level (amplitude) could be decreased gradually during each burst (rather than abruptly) to reach the same final stimulation level.

A more gradual transition at the start of each burst may be more comfortable and be less likely to cause arousal from sleep, and/or reduce the possibility of muscle/nerve fatigue. Accordingly, the INS 1100 may be programmed to deliver a soft start pulse configuration, defined as a pulse train envelope wherein at the start of each burst, each pulse's intensity (e.g., amplitude) is greater than or equal to the previous pulse's intensity, (e.g., a two second pulse wherein the first 100 ms is at 1.85 mA, the second 100 ms is at 1.95 mA, the third 100 ms is at 2.05 mA and the remaining 1700 ms is at 2.1 mA). This pulse configuration is illustrated in FIG. 6G. The pulse train envelope would thus have a stair-like appearance as stimulation increases to the full stimulation plateau.

In another embodiment, a pulse train envelope may employ a soft start to reach full stimulation and subsequently decrease intensity (amplitude) to a retention intensity for the remainder of the stimulation, (e.g., a two second pulse wherein the first 100 ms is at 1.85 mA, the second 100 ms is at 1.95 mA, the third 100 ms is at 2.05 mA, and the next 700 ms is at 2.1 mA, and the remaining 1000 ms is at 1.8 mA). This pulse configuration is illustrated in FIG. 6F. This configuration may provide the benefits of both soft start and retention intensity, wherein the stimulation starts gradually to fully activate the muscle(s), then decreases to a level of less intense stimulation, with the muscle remaining in a contracted position. FIG. 6H shows nested mode, a simplified version of the previously mentioned retention intensity, wherein there is one step up to the full amplitude, and then an equal step down to the retention intensity.

The INS provides two separate stimulation strengths (A & B) with independent parameters (amplitude, pulse width, frequency, duty cycle and phase adjust). Stimulation may be delivered in different therapy modes, examples of which are shown in FIG. 6I. FIG. 6I (traces 1-8) illustrates some commonly used modes, all of which are inspiratory synchronous, meaning stimulation is automatically delivered according to an algorithm that predicts the inspiratory phase and initiates stimulation delivery at a desired time relative to inspiration, such as centered on the predicted inspiration. These modes may be used as standard therapy as well as to determine device settings during a PSG (e.g. sleep titration PSG). Additionally, these modes may be used to diagnose phenotypes of OSA or other diseases.

FIG. 6I (trace 1) illustrates synchronous mode in which every stimulation has the same pulse configuration and amplitude, known as AAAA mode, the default therapy mode. The term AAAA mode means that four consecutive inspirations are covered by stimulation of level A, where A is 2.0 mA, for example. Inspiration is shown in FIG. 6I (trace 9) in the upward direction.

The inspiratory-synchronous ABAB mode, FIG. 6I (trace 2), also delivers stimulation bursts synchronous with inspiration as determined by the device, therapy delivery algorithm settings, and sensed respiratory signal. This mode is similar to AAAA mode, except that the stimulation is delivered on four consecutive inspirations alternating between stimulation levels A and B on each burst where, for example, A is 2.0 mA and B is 1.8 mA.

FIG. 6I (trace 3) illustrates a subset of ABAB mode known as A0A0 mode, wherein the B breath is not stimulated. A may be 2.0 mA and B may be 0 mA, for example.

FIG. 6I (trace 4) illustrates A0B0 mode, wherein a first breath is stimulated at level "A," followed by a second breath that is unstimulated, followed by a third breath that is stimulated at level "B," followed by a fourth breath that is unstimulated, (e.g., A is 2.0 mA and B is 1.8 mA). This allows for simultaneous assessment of two different levels (A and B) when compared to adjacent non-stimulated breaths.

FIG. 6I (trace 5) illustrates AABB mode wherein two breaths are stimulated at level "A" followed by two breaths stimulated level "B," (e.g. A is 2.0 mA and B is 1.8 mA). In this mode, every stimulated breath is adjacent to a stimulated breath at level "A" and a stimulated breath at level "B." The AABB mode may be used to test if there is a short-term residual cross-over effect when changing from one stimulation level to another stimulation level or from a stimulation level to no stimulation. For example, the airflow measured during the first "A" can be compared to the airflow measured

during the second "A" in each sequence over many periods to determine if there is a measurable residual effect from the "B" level stimulation.

FIG. 6I (trace 6) illustrates xAB0 mode, wherein "x" number of breaths are stimulated at level "A," followed by a breath stimulated at level "B," followed by an unstimulated breath, (e.g. A is 2.0 mA and B is 1.8 mA). The illustration shows x equals 3 (3AB0), although x may be any number of breaths (e.g., 3, 5, 7).

FIG. 6I (trace 7) illustrates xA0B mode, wherein "x" number of breaths are stimulated at level "A," followed by an unstimulated breath, followed by a breath stimulated at level "B," (e.g. A is 2.0 mA and B is 1.8 mA). The illustration shows x equals 3 (3A0B), although x may be any number of breaths (e.g., 3, 5, 7).

FIG. 6I (trace 8) illustrates xAB mode, wherein "x" number of breaths are stimulated at level "A," followed by a breath stimulated at level "B," (e.g. A is 2.0 mA and B is 1.8 mA). The illustration shows x equals 4 (4AB), although x may be any number of breaths (e.g., 4, 6, 8).

Stimulation may also be delivered in two modes which are not inspiratory synchronous: manual stimulation and asynchronous (fixed) stimulation. Manual mode delivers stimulation at any frequency, pulse width, amplitude, pulse configuration, and/or duration (e.g., up to 12 seconds). In manual mode, stimulation is delivered by manually entering a command via the programmer system to initiate delivery of a stimulation burst or bursts. The stimulation continues until the burst duration expires or stimulation stop is commanded via the programmer system. Manually delivered stimulations may be delivered in any available pulse configuration.

Asynchronous mode (fixed mode) is when stimulation is delivered at regular programmable intervals (e.g., 2.5 seconds of stimulation, followed by 2.5 seconds off). The intervals may be set to a rate similar to a respiratory cycle, (e.g. 5 seconds). Alternatively, longer intervals (e.g. 8 seconds) may decrease the probability of missing two consecutive inspirations, and increase the probability of providing the patient with stimulation during an entire respiratory cycle. This may be used during daytime familiarization, ensuring that the patient receives stimulation in a regular fashion, as breathing patterns during wakefulness may be more irregular and difficult to predict than during sleep. In addition, this mode may be used to test the benefits of asynchronous stimulation compared to inspiratory synchronous stimulation. Asynchronous stimulation may be initiated by programming the device to fixed mode and starting a therapy session. Fixed mode stimulations may be in any available pulse train configuration.

Typically, stimulation is delivered during a therapy session having a start and a stop time. The patient or physician may start a therapy session using the therapy controller 2500 or programmer system 2100. Additionally, a therapy session may begin according to a programmable schedule. During a session, the start of stimulation may be delayed by a programmable delay, subject to patient preference. The patient or physician may stop a therapy session using therapy controller 2500 or programmer system 2100. Additionally, a therapy session may stop according to a programmable schedule or programmable maximum session duration.

A patient or physician may also pause a therapy session for a programmable time using the therapy controller 2500 or programmer system 2100. This pause function may be programmed to turn stimulation off or reduce the stimulation intensity. The pause function may be programmed to smart

pause, wherein the stimulation level is automatically reduced after a programmable number of pauses (e.g. after the second pause) in a programmable time period or session. Additionally, the smart pause may increase pause duration after a programmable number of pauses (e.g. the first pause is five minutes, the second pause is ten minutes). These pause functions, including smart pause, may allow a patient to reduce stimulation for brief periods following an arousal from sleep.

At the start of a therapy session or following an interruption in therapy such as a pause, stimulation level may increase incrementally from an initial stimulation level to an initial therapy level during a ramping period. The ramp may occur over a programmable number of stimulations, breaths, or time period. This ramp may also occur after a pause or a motion event. The ramping feature may be more comfortable, allowing the patient to fall asleep more easily with the stimulation on or reduce the likelihood of causing arousal from sleep.

A patient may be able to tolerate more intense stimulation as a therapy session progresses. This higher intensity stimulation may provide enhanced therapy efficacy. The INS 1100 may be programmed to change stimulation level (e.g., amplitude or pulse width) during a therapy session from an initial level to a second, possibly more efficacious level. This therapy stimulation configuration is illustrated in FIG. 6J and is called core hours. This intensity change may occur after a programmable interval, for example after a fixed duration of time, number of breaths or stimulations (e.g., stimulation at 1.8 mA for the first hour of a therapy session, after which stimulation is increased to 2.0 mA). This feature and the related parameters may be programmed by a physician, for example based on patient feedback. This feature may allow a patient to fall asleep at a more tolerable level of stimulation, and then as the therapy session progresses, receive more appropriate therapeutic benefit.

Stimulation may be delivered during a therapy session, which may start and stop according to a programmable schedule or manual use of the therapy controller 2500. The therapy controller 2500 may also allow the patient to pause or adjust therapy settings. Summary history data from each session may be saved in the device memory. Data recorded may include: start, pause, and stop times of the therapy session, scheduled or manual starts/stops, motion detector outputs, cycling detector outputs, prediction algorithm outputs, respiration timing, signal stability outputs, accelerometer outputs, impedance data from STL 1300 and RSL 1200, number of breaths, number of stimulations in a session, average and median P-P sensing impedance ("Z") amplitude values, stimulation settings and changes in stimulation settings such as core hours, pulse configuration, and ramping. These summary data allow a physician or caretaker to understand how the patient is using the device, tolerating the stimulation, troubleshoot errors in programming, and estimate the therapeutic effects of the neurostimulator. This feedback data may aid in determining if adjustments are needed to the patient's therapy (e.g. patient is ready for stimulation up-titration).

Programmer System

As shown schematically in FIG. 7A, the programmer system 2100 includes a computer 2300, a programmer interface 2400, a programmer head 2200, and a sleep wand 2700. The programmer interface 2400 and programmer head 2200 are similar in certain aspects to commercially available programmers, which may be obtained from suitable manufacturers such as CCC Medical Devices (Montevideo, Uruguay). The programmer head 2200 is connected to the

programmer interface 2400 via a flexible cable 2210, and the programmer interface 2400 is connected to the computer 2300 via a USB cable 2310. Cable 2210 may be coiled as shown or straight. As shown in FIG. 15, the sleep wand 2700 may comprise a sleep wand head 2720, a flexible cable 2710, and an LED 2730. The sleep wand 2700 may connect to the programmer interface 2400 via a flexible cable 2710. The sleep wand head 2720 may be 3.2 inches in length, 2.1 inches in width, and 0.5 inches deep. The programmer system 2100 wirelessly communicates with the INS 1100 via a wireless telemetry link (e.g., 30 KHz) utilizing an antenna and associated circuitry in the programmer head 2200. The programmer may use long range telemetry such that the programmer head 2200 may rest beside the patient without interfering with sleep. The programmer interface 2400 provides analog to digital conversion and signal processing circuitry allowing the computer 2300 to control and program the INS 1100 via the programmer head 2200. The programmer head includes a power indication LED 2220, a signal strength LED array 2230 (signal strength to/from INS 1100), an interrogate button 2240 (to upload data from INS 1100), a program button 2250 (to download data/commands to the INS 1100) and a therapy-off button 2260 (to stop therapy/stimulation output from the INS 1100). The computer 2300 may comprise a conventional laptop computer with software to facilitate adjustment of a variety of INS 1100 parameters, including, for example: stimulation parameters (stimulation pulse amplitude, stimulation pulse frequency, stimulation pulse width, stimulation duty cycle, etc.); respiration sensing algorithm parameters; stimulation trigger/synchronization algorithm parameters, therapy delivery schedule, and various test functions. The sleep wand 2700 functions like the programmer head 2200, but is reduced in size for patient comfort during sleep. There may be one LED 2730 to indicate signal presence. Frequency of LED light pulses may indicate signal strength. The sleep wand 2700 may exclude functional buttons (i.e. interrogate command, program command, and stop therapy command) found on the programmer head 2200.

With reference to FIG. 7B, a block diagram of example circuits 2420/2270 for the programmer interface 2400 and the programmer head 2200 are shown schematically. The programmer interface circuit 2420 is controlled by a microprocessor having a standard set of peripherals (RAM, flash, digital I/O, timers, serial ports, A/D converter, etc.). The microprocessor communicates with a standard personal computer (PC) 2300 through a Universal Serial Bus (USB) interface. Commands and data are passed from the computer 2300 to/from the microprocessor via the USB interface and cable 2310. The USB interface also provides DC power for the programmer interface circuit 2420 and the programmer head circuit 2270 via cable 2210. The microprocessor controls the cable interface leading to the programmer head circuit 2270 via cable 2210. The programmer head circuit 2270 contains telemetry driver and receiver electronics that interface to the telemetry coil. The telemetry coil is designed to inductively couple signals from the programmer head circuit 2270 to the coil in the INS circuit 1130 when the programmer head 2200 is placed over the INS 1100 with the coils aligned. As an alternative to telemetry coils and an inductive link, RF antennae with associated circuitry may be used to establish a RF link to provide for arms-length telemetry. The programmer head circuit 2270 also contains electronics that monitor the signal strength as received from the INS 1100. The outputs of the signal strength electronics drive display LED's for the user. Another LED indicates that power is available, for example, supplied by the computer

2300. The programmer interface microprocessor controls and receives analog input signals from an isolated sensor interface. The power and ground for the sensor interface are derived from the USB power input, but provide DC isolation for this circuitry to prevent leakage currents from flowing through any patient connections that may be present at the sensor inputs. The sensor inputs may be protected against external high voltages (i.e. defibrillation protection). The sensor input signals are amplified and filtered appropriately for the sensor type. The amplifier gain and filter characteristics may be controlled by microprocessor. The signals to/from the amplifier circuit are DC isolated to prevent leakage currents from flowing through any patient connections that may be present at the sensor inputs. The sensor signals are digitized by the microprocessor and are transmitted through the USB link to the PC along with the telemetered signals from the INS **1100** for recording and display.

With reference to FIG. 7C, a block diagram of example circuit **2440** for the marker box **2430** is shown schematically. Generally, marker box **2430** and associated circuitry **2440** replace the D/A circuits and analog outputs **2410** of programmer interface circuit **2420** shown in FIG. 7B providing for the alternative arrangement illustrated in FIG. 10B. The marker box circuit **2440** is separately connected to a Universal Serial Bus (USB) port of the programmer computer **2300** via a USB cable. The USB interface also provides DC power for the marker box circuit **2440** via the USB cable. The power and ground for the marker box circuit **2440** are derived from the USB power input, but provide DC isolation for this circuitry to prevent leakage currents from flowing through any equipment that may be connected to the patient. Analog marker output data signals are transmitted from the PC **2300** to control the digital to analog (D/A) converter outputs. These analog output signals may be connected to standard PSG recording equipment **2800**. Signals from the INS **1100** (such as sensed respiration impedance and stimulation output timing and amplitude) can be represented by these outputs to allow simultaneous recording with other standard PSG signals (flow, belts, EMG/ECG, etc). The programmer **2300** may be enabled to automatically switch programmable settings at regular time intervals, allowing respiratory sensing vectors, stimulation levels, stimulation modes, or stimulation pulse configurations to be altered at specified intervals during sleep. Sampled values may be selected such that only a limited number of settings are sampled.

As mentioned previously, the INS **1100** records session summary data. The programmer computer **2300** may display these data using text and images to graphically display device settings, session data, and analyses of data. This data may be used to evaluate system performance and guide programming of settings. The patient's name or identifier may be stored in the INS **1100** and/or displayed on the programmer computer **2300**. All text and symbols displayed by the programmer **2300** may be in a variety of selectable languages. The programmer **2300** may have the capability to connect to the internet. Through this connection files may be uploaded to a database to enable remote real time monitoring of device operation, recorded data and settings. The connection may also be used to update the programmer application software and or the (indirectly) the INS firmware.

The programmer **2300** may display and tag data to a variety of dates and times. These times may programmed to take into account daylight savings time, local time, Greenwich Mean Time, or a free-running counter in the INS **1100**.

The programmer **2300** may display the voltage (or other capacity measurements) of battery **1140**. In addition, an elective replacement indicator (ERI) and end of life (EOL) indicator may be displayed on the programmer as the battery nears depletion. There may be several months from ERI to EOL or alternatively, two months from ERI to EOL, with an estimated one month of use after EOL.

Therapy Controller

As shown schematically in FIG. 8A, the therapy controller **2500** may be used by the patient to control limited aspects of therapy delivery. The therapy controller **2500** is similar in certain aspects to commercially available patient controllers, which may be obtained from suitable manufacturers such as CCC Medical Devices (Montevideo, Uruguay). The therapy controller **2500** houses a battery, an antenna, and associated circuitry (not visible) to control limited aspects of therapy delivery via a wireless telemetry link (e.g., 30 KHz) with the INS **1100**. Therapy is normally operated in a manual mode but may also be set for automatic delivery according to a predefined schedule (set by physician using the programmer during titration). The therapy controller has a user interface including start button **2510** (to start therapy delivery), a stop button **2520** (to stop therapy delivery) and a pause button (to pause therapy delivery or reduce stimulation intensity to a programmable value), each with associated LED indicators **2540** which flash when the corresponding button is depressed and illuminate steadily when the command is received by the INS **1100**. The buttons may be backlit when pressed for ease of use at night. The user interface also includes a schedule set LED **2550** that illuminates if a therapy delivery schedule has been programmed, and a contact physician LED **2560** that illuminates in the event of a low battery or a malfunction requiring a physician visit. In addition, this light may illuminate at ERI or EOL time points.

The therapy controller may have additional functionality (e.g., more buttons) which can be set to give the patient limited control over select therapy settings. These settings include, but are not limited to, stimulation intensity (e.g., amplitude), stimulation mode, pulse train configuration, core hours stimulation settings, ramp, programmable schedule, clock, and motion inhibit programmable values.

As mentioned previously, the INS **1100** contains data, including metrics from therapy sessions. The therapy controller **2500** may wirelessly communicate with the INS **1100** to download any data to the INS. This data may be stored in internal memory or removable memory such as a USB flash drive or smart card. This data may be uploaded (e.g. from the patient's home computer) for the physician to read. This may allow the physician to monitor device use, home efficacy, or the patient's acclimation.

An alternative embodiment of the user interface may include an LCD display or a touchscreen. This allows for multiple functions to be integrated into the therapy controller while keeping the interface simple. This may also allow for larger text.

With reference to FIG. 8B, a block diagram of an example circuit for the therapy controller **2500** is shown schematically. The therapy controller circuit **2570** includes a battery powered microprocessor having a standard set of peripherals (RAM, flash, digital I/O, timers, serial ports, A/D converter, etc.). The microprocessor operates in a low power mode to conserve battery power. The microprocessor controls the telemetry driver and receiver electronics that interface with the telemetry coil. The telemetry coil is designed to inductively couple signals to the INS telemetry coil when aligned. The microprocessor monitors the membrane switches and

reacts to switch closures by activating display LED's and initiating telemetry commands to the INS. As an alternative to telemetry coils and an inductive link, RF antennae with associated circuitry may be used to establish a RF link to provide for arms-length telemetry. After communicating with the INS, status information can be displayed to the user. The microprocessor also controls a beeper which can provide audio feedback to the user when buttons are pressed and to indicate the success or failure of communications with the INS. The beeper may have a mute function or volume control.

Magnet

As schematically shown in FIG. 9, an annular magnet **2600** may be provided to the patient to inhibit the INS **1100** in the event the therapy controller **2500** is not available or functioning. The magnet **2600** may comprise a permanent annular-shaped magnet made of ferrite strontium material coated with epoxy. The magnet **2600** may produce a strong field of 90 Gauss at 1.5 inches from the surface of the magnet along the centerline of the hole. The magnet **2600** may be used (or carried by) the patient in case of emergency. When temporarily (2 seconds or more) placed over the implanted INS **1100** on the skin or clothing, the magnet **2600** disables current and future therapy sessions. Although therapy sessions are disabled by the magnet **2600**, all other functions of the INS **1100** may remain enabled including telemetry communication with the programmer system **2100** and therapy controller **2500**. Therapy sessions may be re-enabled using the therapy controller **2500** by initiating a new therapy session. Alternatively, the therapy may be temporarily inhibited during placement of the magnet. If left in place for a specified time period (e.g. one minute), therapy may be deactivated.

Interface with PSG Equipment

The programmer interface **2400** may include an input/output (I/O) link **2410** to allow connection to polysomnographic (PSG) equipment **2800** as schematically shown in FIG. 10A. Typical PSG equipment **2800** includes a computer **2810** connected to a plurality of sensors (e.g., airflow sensor **2820**, respiratory effort belts **2830**) via interface hardware **2840**. The I/O link **2410** may be used in a number of different ways. For example, analog data signals from the PSG equipment **2800** may be downloaded to the computer **2300** of the programmer system **2100** to record and/or display PSG data (e.g. airflow) together with therapy data. Alternatively or in addition, digital data signals from the INS **1100** and/or the programmer system **2100** may be uploaded to the computer **2810** of the PSG equipment **2800** to record and/or display therapy data (e.g., stimulation amplitude, stimulation pulse width, and/or respiration data such as bio-impedance, vector, filter settings, prediction markers, or accelerometer data) together with PSG data. The circuitry corresponding to I/O link **2410** may be incorporated into the programmer interface **2400** as shown in FIG. 10A, or may be incorporated into a separate marker box **2430** as shown in FIG. 10B.

Synchronizing data from the sensors **2820/2830** of the PSG equipment **2800** with data from the INS **1100** via the programmer system **2100** may be beneficial to facilitate therapy titration and efficacy measurement. Although the programmer system **2100** and the PSG equipment **2800** may be directly connected by I/O link **2410**, transmission delay in each system may result in asynchrony. Data synchronization between the systems may be addressed in a number of different ways. For example, if the delays in each system are relatively fixed and below an acceptable threshold (e.g., 0.5 to 1.0 second), no synchronization step need be taken. If

the delays in each system are relatively fixed but above an acceptable threshold (e.g., above 0.5 to 1.0 second), data from the system with less delay may be offset (delayed) by a fixed time value to align with data from the system with more delay. As an alternative, a timing signal (e.g., from a clock signal generator separate from or integral with one of the systems) may be input into the PSG equipment **2800** and programmer system **2100** to allow time stamped data independently collected by each system to be merged and synchronized by post processing.

Treatment Overview

FIG. 12A illustrates a treatment overview from implant **10100**, to awake titration **10200**, to daytime familiarization **10400**, to sleep titration **10500**, to nighttime familiarization **10700**, to up-titration **10800**, and finally to regular therapeutic use **11000** and therapy assessments **11100**.

Beginning with a surgical implant **10100**, FIG. 11A schematically illustrates the incision sites (solid thick lines) and tunneling paths (dotted lines) for implanting the INS **1100**, STL **1300** and RSLs **1200**. The implant procedure may be performed by a surgeon (e.g., otolaryngologist) in a 1-3 hour surgical procedure with the patient under general or local anesthesia, for example. In general, the implant procedure involves placing the cuff **1350** of the STL **1300** on the hypoglossal nerve via a submandibular dissection, and tunneling the lead body **1330** and sigmoid section **1370** of the STL **1300** subcutaneously down the neck to the INS **1100** in a subcutaneous pocket in the infraclavicular region. From the infraclavicular pocket, the RSL **1200** may be tunneled subcutaneously toward midline and then laterally along the costal margins.

After a healing period of a few weeks, an awake titration may be performed **10200** wherein the patient's tongue response to stimulation is observed over a range of comfortable stimulations, as illustrated in FIG. 12B. In addition, a global system check may be performed to check the system integrity. The patient is then sent home for a period of daytime familiarization **10400** where the patient may turn on stimulation during wakefulness to introduce the sensation of stimulation. The patient subsequently returns to the sleep lab for a sleep titration **10500** where a sleep technician, under the supervision of a certified sleep physician (e.g., pulmonologist), uses the programmer system **2100** to program the INS **1100** (e.g., set the therapy delivery schedule and titrate the stimulus to determine a range of efficacious settings during sleep). After the sleep titration, the patient may return home and begin the nighttime familiarization (acclimation) and therapy up-titration process, wherein stimulation may be increased over time to an efficacious range. For example, the patient may leave the sleep titration with stimulation programmed to turn on at 1.7 mA and stimulation may be increased by 0.1 mA at two week intervals up to a goal setting of 2.0 mA.

Immediately after the titration visit, the patient may return home and begin using the device at the programmed stimulation level during nighttime familiarization **10700**. A therapy delivery session may begin when the therapy controller **2500** is used to manually start, stop, and pause a therapy session. This may be beneficial when the patient has an irregular sleep schedule. At the beginning of a therapy delivery session, stimulus may be delayed for a period of time to allow the patient to fall asleep. The therapy delivery session may be programmed to not exceed a fixed number of hours (e.g., eight hours). In addition, a therapy delivery session may begin according to the pre-defined therapy delivery schedule, which may be set to coincide with when the patient normally goes to sleep. The therapy delivery

session may end according to the pre-defined therapy delivery schedule, which may be set to coincide with when the patient normally wakes up, or with a manually stop command from the therapy controller. The patient may use the therapy controller **2500** to adjust limited aspects of therapy delivery as defined previously.

Tunneling System

FIGS. **11B** and **11C** schematically illustrate the tunneling system **3000** which may be used for tunneling the STL **1300** or RSL **1200**. The tunneling system **3000** includes a relatively rigid tool **3010**, a tubular sheath **3020**, and a tip **3030**, and lead carrier **3100**.

The tool **3010** may be formed of stainless steel and include a handle **3016**, a shaft **3012**, and a distal connector **3018**. The connector **3018** includes threads that mate with corresponding threads in the tip **3030**. The connector **3018** may also include ring barbs that form an interference fit with the inside of the lead carrier **3100** for releasable connection thereto. The lead carrier **3100** may also form an interference fit with the RSL proximal connector **1210**, the STL proximal connector **1310**, or a distal ring electrode of the RSL **1250** or **1260**.

The sheath **3020** is sized to be slid over the tool **3010** and secured in place via the tip **3030**. The tip **3030** may include a radiopaque agent such as barium sulfate loaded at 18% by weight, for example.

The lead carrier **3100** may comprise a small polymeric tube with an inside diameter sized to form an interference fit with the distal connector **3018**, the RSL proximal connector assembly **1210**, an RSL distal electrode **1250** or **1260**, or the STL proximal connector assembly **1310**. During tunneling, the proximal end of the lead carrier **3100** may attach to the distal connector **3018** and the distal end of the lead carrier **3100** may attach to the RSL proximal connector assembly **1210**, an RSL distal electrode **1250** or **1260**, or the STL proximal connector assembly **1310**.

The sheath **3020** may comprise a polymeric tube with two open ends, and the tip **3030** may comprise a polymeric tube with one threaded end and one closed end for blunt dissection. The proximal end of the tip **3030** includes internal threads to screw onto the connector **3018** and hold the sheath **3020** on the shaft **3012**.

In the embodiment shown in FIGS. **11B** and **11C**, the tool **3010** may have a pre-bend length of 17.1 inches and a post-bend length of 16.9 inches. The sheath **3020** may have an outside diameter of approximately 0.28 inches, a pre-bend length of 12.4 inches and a post bend length of 12.25 inches. The shaft **3012** may have a diameter of about 0.22 inches, a pre-bend length of 12.375 inches, and a post-bend length of 12.231 inches, sufficient to fill the length of the sheath **3020**. The handle **3016** may have a diameter of about 0.5 inches and a length of about 3.50 inches. The tip **3030** may have an outside diameter tapering from approximately 0.13 inches and a length of about 1.0 inches.

Surgical Implant Procedure

With continued reference to FIG. **11A**, the internal components **1000** may be implanted using the following surgical procedure **10100**, which is given by way of example, not limitation. Unless specifically stated, the order of the steps may be altered as deemed appropriate. Although the INS **1100** may be surgically implanted on the right or left side, the right side is preferred to leave the left side available for implantation of cardiac devices that are traditionally implanted on the left side. The right side is also preferred for the RSL **1200** to provide a clean respiratory signal that is less susceptible to cardiac artifact than the left side.

Standard surgical instruments may be used for incisions, dissections, and formation of subcutaneous pockets. Commercially available nerve dissection instruments may be

preferred for dissecting the hypoglossal nerve and placing the STL cuff **1350** on the nerve.

The patient is prepared for surgery using conventional practice including standard pre-operative care procedures, administration of antibiotics as appropriate, and administration of steroids as appropriate to reduce swelling around the nerve dissection. Because tongue movement must be observed during test stimulation, it is recommended that no long-acting muscle relaxants be used during surgical preparation or during implant. General anesthesia is administered according to conventional practice and the patient is intubated using an endotracheal tube, taking care to position the endotracheal tube so that the tongue is free to protrude during test stimulation.

The neck is then extended to expose right submandibular region and a sterile field is created around the neck and thorax, taking care to avoid obstructing visualization of the oral cavity (a clear sterile drape over the mouth may be used). By way of a neck incision (A), the hypoglossal nerve is then exposed deep to the submandibular gland. Because the INS **1100** is preferably implanted on the right side to minimize cardiac artifact during respiratory sensing, this dissection is also preferably performed on the right side. A region of the hypoglossal nerve, preferably excluding the branch that innervates retrusive muscles (e.g. styloglossus or hyoglossus), is then identified and isolated. Confirmation of correct nerve location may be achieved by performing a test stimulation later in the procedure. The identified nerve branch is then circumferentially dissected to accommodate the cuff **1350**. The short side **1352** of the cuff **1350** is designed to reside on the deep side of the nerve, and the long side **1354** of the cuff **1350** is designed to reside on the superficial side of the nerve.

The appropriate sized cuff **1350** is then selected based on the nerve diameter at the intended location for cuff placement. Nerve size may be assessed using reference size (e.g., forceps of known width), a caliper, or a flexible gauge that wraps around the nerve, for example. The cuff **1350** is then opened and placed around the nerve. The strap **1356** on the cuff **1350** may be used to facilitate placement of the cuff **1350** around the nerve. A curved forceps may be placed under the nerve to grasp the strap **1356** and gently pull the cuff **1350** onto the nerve. The strap **1356** is then placed through the loop (buckle) **1358** on the cuff **1350**. The cuff **1350** may be available in two sizes (small and large), and the small cuff may have an indicator mark (not shown) on the strap **1356** that should be visible after insertion through the loop **1358**. If a small cuff is selected and the indicator mark does not pass through the loop, the small cuff may be too small and should be replaced with a large cuff.

A strain relief loop (L) in the STL **1300** is then created by arranging approximately 6 cm of the STL sigmoid body **1370** in a C-shape inside a small subcutaneous pocket formed via the neck incision (A) by blunt dissection superficially along the lateral surface of the digastric muscle in a posterior direction.

The surgeon then verifies that the cuff **1350** is not pulling or twisting the nerve, and that there is contact between the inside of the cuff **1350** and the nerve.

A test-stimulation is then performed to confirm correct positioning of the cuff **1350** on the nerve. To conduct a test-stimulation, the proximal end of STL **1300** is plugged into the INS **1100** and the programmer system **2100** is used to initiate a test stimulation signal delivered from the INS **1100** to the nerve via the STL **1300**. The test stimulation is performed while observing, for example, tongue movement by direct visual observation, airway caliber by nasal endoscopy, fluoroscopy, cephalogram, etc. Correct placement of the cuff on the nerve may be confirmed by, for example,

observing tongue protrusion, an increase in retro-glossal airway caliber, an increase in retro-palatal airway caliber, an increase in stiffness of the anterior and/or lateral walls of the retro-glossal airway with or without an increase in airway caliber, anterior movement without superior movement of the hyoid bone, among others. Incorrect placement of the cuff on the nerve is indicated, for example, when there is insufficient opening of the retro-palatal or retro-lingual space, when the tongue is observed to retract (posterior movement), a decrease in retro-glossal airway caliber, a decrease in retro-palatal airway caliber, superior movement and particularly unilateral superior movement of the hyoid bone, among others. If necessary, the cuff **1350** may be repositioned at a different location along the length of the nerve to obtain the desired effect. The capture threshold and impedance values are recorded and the STL **1300** is disconnected from the INS **1100**. The surgeon may create a fascia wrap by suturing fascia around the cuff on the superficial side of the nerve.

A pocket for the INS **1100** is then created by making an incision (B) down to the pectoralis fascia approximately 2 finger breadths below the right clavicle. The INS **1100** is preferably implanted on the right side to minimize cardiac artifact during respiratory sensing. Blunt dissection inferior to the incision is used to create a pocket large enough to hold the INS **1100**. The pocket should be inferior to the incision (B) such that the incision (B) does not reside over the INS **1100** when later placed in the pocket.

A tunnel is formed for the STL **1300** using the tunneling system **3000** (sheath **3020** and tip **3030** placed over tool **3010**) to tunnel along a path (C) from the infraclavicular INS pocket to the neck incision (A). As shown in FIG. **11C**, the lead carrier **3100** is then placed on the most proximal electrical contact of the STL proximal connector **1310**. The tip **3030** is removed from the sheath **3020** to expose the connector **3018** of the tool **3010** and attach to the lead carrier **3100**. While holding the sheath **3020** in place, the tool **3010** is pulled proximally to pull back the STL **1300** through the sheath **3020**, taking care not to pull out the C-shaped strain relief or disturb the cuff. If the C-shaped strain relief loop (L) is pulled out, it should be replaced into the small pocket. The tool **3010** is released from the lead carrier **3100** and the lead carrier **3100** is removed from the STL **1300**. The sheath **3020** is then removed from the body leaving the STL **1300** in place. The neck incision (A) need not be closed at this time, but rather may be closed later in the procedure allowing confirmation that the C-shaped strain relief remains in the small pocket.

The following implant instructions refer to an INS **1100** implanted at the patient's right sub-clavicular region. The right and left distal portions of the RSL **1200** are placed near the right and left costal margins, respectively, by making four small incisions (D and E) as shown. The lateral incisions (E) may be made approximately 80% (+/-5%) of the distance from the midline to the mid-axillary line, and on the costal margin. The medial incisions (D) may be made such that the RSL **1200** is relaxed and all electrodes are on the costal margin. Using the tunneling system **3000** (sheath **3020**, tip **3030** attached via connector **3018**), a tunnel (G) is formed between the pocket (B) and the medial incision (D), such that the right distal portion of the RSL **1200** may be pulled through the tunnel (G) from the pocket (B) to the medial incision (D). A tunnel (F) is then formed between the medial incision (D) and lateral incision (E), such that the right distal portion of the RSL may be pulled through the tunnel (F) from (D) to (E). This is repeated for the left distal portion of the RSL **1200**. Alternatively, if the embodiments

of RSL **1200** shown in FIG. **4F** or **4G** are used, a small pocket may be formed medial to (D) in order to accommodate the medial electrodes and/or loop back region **1255**.

The previously described tunneling operations (F and G) may be performed as follows: The tunneling tool **3010** including the connector **3018** is inserted into the sheath **3020** and the tip **3030** is connected to the connector **3018**, forming the tunneling system **3000**. The tunneling system is placed in the origination incision site and pushed beneath the skin towards the destination incision site, forming a tunnel. After tunneling, the tip **3030** is removed from the connector **3018** of the tunneling tool **3010**. If needed, the tool **3010** may be removed and reversed such that the connector **3018** is at the other end of the sheath **3020**. With the tool **3010** inserted through the sheath **3020**, the lead carrier **3100** is attached on its proximal end to the connector **3018** and on its distal end to the distal electrode **1250** or proximal connector **1210** of the RSL **1200**. While holding the sheath **3020** in place, the tunneling tool handle **3016** is pulled and the attached lead carrier **3100** and RSL **1200** are pulled into the sheath **3020**. This may be visualized through the semi-transparent tunneling tool. The sheath **3020** may then be slid towards the tunneling tool handle **3016**, exposing the lead carrier. The lead carrier may then be disconnected from the connector **3018**, leaving the RSL **1200** in place. This process may be used to tunnel from (D) to (B) and subsequently from (E) to (D). For tunnel (G), the RSL **1200** may be pulled completely through the sheath **3020** to expose and disconnect the lead carrier.

Each anchor tab **1270** and suture hole **1290** is secured to the underlying tissue by dissecting down to the adjacent muscle fascia and suturing each anchor tab **1270** or suture hole **1290** to the muscle fascia. Permanent sutures are recommended to avoid movement of the RSL **1200** and braided suture material is recommended for knot retention and to prevent corrosion through the silicone anchors.

The STL **1300** and RSL **1200** are then connected to the INS **1100**. The RSL **1200** is plugged into the RSL port **1112** and the STL **1200** is plugged into the STL port **1114**. The set screws are tightened using a torque wrench.

A closed loop test may be performed to confirm proper operation by observation of tongue protrusion or airway opening in concert with inspiration. The INS **1100** and proximal portions of the leads **1200/1300** are then placed into the infraclavicular pocket, looping the excess lead length beneath or around the INS **1100**. Care should be taken not to pull out the C-shaped strain relief loop (L) in the STL sigmoid lead body **1370** while manipulating the INS **1100** into place. The INS **1100** is then sutured to underlying fascia through both suture holes **1116** found in the header **1110** of the INS **1100**. Permanent sutures are recommended to avoid movement of the INS both before tissue encapsulation and chronically, and braided suture material is recommended for knot retention. Another system test may be performed at this point. After confirming that the C-shaped strain relief loop (L) is present in small pocket at neck incision, the incisions may be irrigated (optionally with an antibiotic solution) and closed using conventional techniques. After a healing period of approximately one month, the patient may undergo a sleep study to confirm proper operation of the system and to titrate therapy.

Screening Methods

Prior to implant, patients may be screened to estimate the probability of a successful outcome.

The airway can be characterized during sleep by a Pcrit measurement in differing sleep stages and body postures, per the methods of Schwartz et al. A higher Pcrit value is

indicative of a more collapsible airway which may be more difficult to treat with this therapy. A surrogate measure for Pcrit may be an auto-PAP device that adjusts airway pressure dynamically to eliminate flow limitation. For example, a patient may require 12 cm H₂O of air pressure to maintain a patent airway in the supine position, yet only require 8 cm H₂O of air pressure in the lateral position. The auto-PAP would automatically adjust for this.

The volume of air expired during a pressure drop may be measured. The pressure drop may occur during natural expiration during wakefulness. Alternatively, the patient may be asleep during the measurement. The timing of the pressure drop during expiration may occur at a certain point during expiration to ensure consistency. The duration of the pressure drop may be fixed. An example of this measure is $V_{NEP, 0.5}$.

The airway may be visualized using an imaging modality such as, but not limited to, cephalogram, MRI, fMRI, CT, ultrasound, OCT, naso-endoscopy, photography, and video imaging. This imaging may be performed during sleep, under sedation, or during wakefulness. The patient may be asked to protrude the tongue, inhale/exhale at specific flow rates, or perform Muller's Maneuver. Tongue protrusion force may also be measured. Tongue size may be observed and/or measured quantitatively or qualitatively (e.g., Modified Mallampati). BMI may also be a good predictor of patient response.

The following metrics (and others) may be measured and used in screening: size of tongue and soft palate, angle of the soft palate, redundancy of tissue, and length of soft palate. Endoscopy is one method for obtaining these metrics. Additional size metrics include craniofacial structures, tonsil size, adenoids, pharyngeal fat pads.

Mechanical linkage or coupling between airway structures may also be assessed. For example, airway opening may be measured at different levels concurrent with other motions, (e.g. measuring opening of the airway at the retro-palatal space during voluntary tongue protrusion or anterior displacement of the tongue).

Nasal airway collapse may be measured using nasal peak inspiratory flow meters in different body positions. Additionally, acoustic rhinometry may provide another way to measure this.

Body Mass Index (BMI) may be a useful tool in screening. Additional metrics include % body fat, % visceral fat, neck circumference, % neck fat, and body fat distribution.

A patient's arousal threshold from sleep may be quantified by measuring intra-pleural arousal pressure. A nasal EPAP device may be used in screening. An EPAP device reduces airflow through the nares. This may increase airway patency during the expiratory phase of respiration. An example of EPAP is the ProVent device (Ventus Medical Inc., Belmont Calif.). Arousals and respiratory events may be assessed with and without the EPAP device. During therapy, the patient's tongue may protrude past the teeth. A dental examination (i.e. identify sharp teeth), patient's use of dentures, and tolerance to oral appliances may be used in screening.

The airway may be characterized using a dual air pump, and valve system, configured for connection to a mask on the patient. In this configuration, the two different pressures (e.g., difference of 1 cm H₂O) are maintained by each pump which is connected to the valve. The valve may be attached via a tube to the mask such that the pressure at the mask is from only one of the pumps. The valve may then be automated to alternate between the two pressures at a programmable rate (e.g., 1 Hz). This allows the airway to

fluctuate between pressures within breaths. An airway may be characterized by lowering the pressure to a level that brings flow limitation, and then observing what pressures remove this flow limitation.

Awake Titration

As described previously, the patient may undergo an awake titration **10200**, an iterative process where the response to stimulation is documented over a range of comfortable stimulation levels (FIG. **12B**). These stimulations may be delivered manually (e.g., 2 second commanded stimulation bursts) or synchronous with respiration. A range of amplitudes may be tested across multiple frequencies (range of 20 to 50 Hz, nominal 40 Hz), and pulse widths (range of 30 to 215 μ s, nominal 90 μ s) **10220**.

The awake titration may involve defining a wake-stimulation operating window, defined at its lower limit by a capture threshold and at its upper limit by a discomfort threshold. The capture threshold may be defined as the lowest stimulation level at which muscle contraction is visible, palpable, or perceptible (e.g., gross tongue movement or stiffening) is observed. The discomfort threshold may be defined as the lowest stimulation level at which the patient experiences an unacceptable sensation (e.g., discomfort, pain) while awake.

While determining this range, the patient may be in the supine position or alternatively, in a posture typical of sleep. In general, during the stimulation titration, it is preferable to begin with the lowest settings for pulse width (30 μ s) and amplitude (0.4 mA) at a nominal frequency (40 Hz). If stimulation produces pulsatile (vibrating) contractions, the frequency may be increased to 50 Hz. The pulse width is incrementally increased to 60 μ s, then to nominal (90 μ s), keeping Amplitude at 0.4 mA. With the pulse width set to 90 μ s, amplitude may be iterated according to the process described hereinafter. If maximum amplitude is reached and additional intensity is required, the pulse width may be increased while reducing amplitude to minimum (0.4 mA). If maximum pulse width (215 μ s) is reached and additional intensity is required, frequency may be increased while reducing the pulse width to 90 μ s and the amplitude to minimum (0.4 mA).

At each stimulation level, observations may be recorded such as: visible tongue motion, palpable genioglossus muscle contraction, perception of muscle movement, tongue protrusion, tongue retrusion, tongue depression, tongue flattening, tongue cupping, and tongue protrusion past the teeth **10230**.

After awake titration **10200**, the patient may be sent home at a stimulation level in this operating range, beginning the daytime familiarization period **10400**. This may occur prior to the sleep titration night, such that the patient may acclimate to the sensation of stimulation. This may allow higher levels of stimulation to be assessed during the sleep titration without patient arousal. Patients have been observed to tolerate (i.e., not arouse) higher stimulation intensities while asleep compared to wakefulness, so the arousal threshold may be higher than the wake discomfort threshold.

Sleep Titration

As described previously, after implantation and a healing period of approximately one month, the patient may undergo a sleep (PSG) study to confirm proper operation of the system and to titrate therapy stimulation levels **10500**. Titration may utilize the set-up illustrated in FIG. **10**, wherein the programmer system **2100** interfaces with the PSG equipment **2800**. Generally, it is preferable to use an oro-nasal mask in order to measure airflow. Alternatively, a nasal cannula may be used. The preferred configuration is a

calibrated pneumotach with the oro-nasal mask to measure the patient's airflow 10510. Alternatively, an uncalibrated pneumotach may be used. A thermistor or a thermocouple may also be used to sense airflow. The thermistor or thermocouple may be calibrated or uncalibrated.

FIG. 14 illustrates an example of a patient's airflow response to stimulation. As shown in FIG. 14, the inspired airflow increases as stimulation delivered to the nerve increases. The airflow capture threshold is the stimulation level at which an increase in airflow is first observed. As stimulation continues to increase, muscle (i.e. genioglossus) activation and airflow also increase. Prior to full muscle activation, a stimulation level which first removes respiratory events is observed. At full muscle activation, increasing stimulation does not increase airflow, resulting in an airflow plateau. The patient may arouse due to stimulation at a level on the plateau. Data comprising this curve may be acquired during a sleep titration PSG for each patient.

The sleep titration process is illustrated schematically in FIG. 12C. Titration generally involves establishing an effective range of stimulation settings 10540, where the lower end is defined by the lowest stimulation level where respiratory events (e.g., apneas, hypopneas, oxygen desaturations, etc.) 10550 begin to decrease or airflow begins to increase, and the range's upper end is defined by stimulation that arouses the patient. A goal setting at which the patient is effectively treated (i.e. respiratory events removed) may be estimated.

During a sleep titration, device settings may be programmed using the programmer system 2100. At the start of titration, most stimulation settings will be at their default values (40 Hz frequency, 90 uS pulse width, 50% stimulation duty cycle, 0 ms phase adjust, etc.). Titration typically consists of many series of "ramps" in different body positions and sleep stages, wherein each ramp is a series of intervals where the stimulation intensity is increased from the previous interval in a certain stimulation mode 10540, illustrated in FIG. 13. For example, at 40 Hz, 90 uS, in A0A0 mode, stimulation level of the "A" breaths could be incremented every two minutes, from the nerve capture amplitude to the amplitude that causes arousal, as illustrated in FIG. 13 trace 3. Ramps are typically performed in A0A0, ABAB, AABB, A0B0, or AAAA modes, as illustrated in FIG. 13, traces 1, 2, 3, and 5. In addition, ramps may be performed using any of the previously discussed modes, also shown in FIG. 13. At each interval, observations are made as to whether stimulation causes arousal, reduces respiratory events, or increases airflow (e.g., increased $V_{i, max}$).

Alternative stimulation modes (not illustrated) may be utilized during wakefulness or sleep, (e.g. during a sleep titration PSG). An alternative mode may be xAy0 mode, where stimulation is delivered for "x" breaths wherein "x" is a programmable number of breaths, followed by "y" breaths with no stimulation wherein "y" is a programmable number of breaths. For example, in mode 4A40, stimulation is delivered on four consecutive breaths followed by no stimulation on four consecutive breaths.

A0A0 mode may be useful in determining if a stimulated breath has more flow than an adjacent unstimulated breath. In the same manner, ABAB and AABB modes may be useful in determining if a stimulated "A" breath provides more flow compared to an adjacent breath with less stimulation, "B." Likewise, A0B0 mode may be useful in comparing flows during "A" stimulation, "B" stimulations, and unstimulated breaths. During a ABAB, AABB, and A0B0 ramps, the difference in stimulation between "A" and "B" stimulations may be constant. ABAB, AABB, and AAAA

ramps may also be useful in determining absolute flow (e.g., tidal volume, minute volume, etc.) and determining what level of stimulation reduces or eliminates respiratory events, since stimulation is delivered every breath. These observations may be recorded for future reference (e.g. physician use). Each stimulation mode may be combined with any of the pulse configurations, such as nested stimulation, soft start, or retention intensity, as chosen by physician or technician.

When a stimulation level is estimated to be efficacious, it may be tested in AAAA mode for a fixed time (e.g., five minutes) after which stimulation may be turned off for a fixed time (e.g., five minutes). If stimulation noticeably reduced or eliminated respiratory events compared to no stimulation, the settings may be considered the goal setting.

Additional titration PSG studies may be performed, either as a separate sleep study or as a split night study. In order to compare multiple stimulation settings during sleep, a cross-over PSG study may be performed wherein the stimulation settings are changed at fixed intervals throughout the night, toggling through a select group of settings. For example, stimulation may alternate between two stimulation settings every five minutes. Afterwards, respiratory events may be determined for each interval such that an index (e.g., AHI, ODI, etc.) can be calculated for each stimulation setting. This may be useful to gauge whether an increase in stimulation would provide additional therapeutic benefits or to gauge whether a decrease in stimulation would not lessen any therapeutic benefits. In addition, the oxygen sensor of the INS 1100 may be used to measure oxygen de-saturations and calculate an ODI.

Another type of titration PSG may be a characterization night, per the methods of Schwartz et al, such that a Pcrit may be determined in REM/nREM sleep, both supine and lateral. Another type of sleep study is the home PSG study, which may be utilized to assess efficacy without the burden of an in-lab PSG. Many home PSG systems are available for use.

The patient may also undergo a vector-sweeping sleep study, wherein the programming system 2100 and a respiratory signal (e.g., nasal cannula) are utilized, 10520. During this study, the secondary vector may be changed at regular intervals to cycle through a select group of vectors. These vectors are compared to the primary vector to determine an optimal sensing vector to deliver therapy. Selection may be based on maximum signal strength, consistent correlation to respiratory fiducials (e.g., offset of inspiration), and maximum signal stability/reliability across sleep stages, body positions, and disordered breathing events, for example. A stable signal has a minimum probability of signal inversion. A reliable signal has a minimum probability of signal loss, and may preferably have a minimum threshold of 0.1 to 0.5 Ohms peak-to-peak, for example. The optimal vector may be selected by incrementally scrolling through all or a preferred subset of possible vectors while sampling the respiration signal and comparing the signal against themselves or predefined thresholds. This scrolling technique may be performed manually (with inputs via the programmer system) or automatically (i.e., programmed). The sampling technique may also be performed manually (visual observation using programmer system) or automatically (i.e., programmed).

Post-Sleep-Titration: Nighttime Familiarization and Up-Titration

After titration, the patient is typically sent home with the device active and stimulation set to a level at which she can fall asleep. This begins the post-sleep-titration process, as

illustrated in FIG. 12D. This process may include nighttime familiarization, up-titration of stimulation, and determining efficacy 10700, 10800, and 11100.

The stimulation settings at which the patient is sent home may initially be below the estimated goal settings. As the patient becomes acclimated to sleeping with the device on 10700, stimulation may be slowly incremented, over the course of days, towards the range where therapeutic effects were observed during the sleep titration and ultimately towards the estimated goal settings. This period is known as up-titration 10800. These increments may be performed by a physician or caretaker, or by the patient, if the physician allows the patient to have limited control of stimulation via the therapy controller 2500.

Several feedback parameters may aid in determining the appropriate time to up-titrate a patient 10810. These include the device's therapy history of frequency and duration of therapy sessions, patient feedback (e.g., more daytime energy, no tongue abrasions, stimulation not causing arousal or pain, etc.), patient's bed-partner feedback (e.g., reduced snoring, perceives patient to be less sleepy, etc.), and most notably, a PSG study. Taken together, these may show whether the patient needs more time to acclimate to stimulation, is ready to have stimulation increased 10840, is receiving therapeutic benefits, or is fully treated. In addition, these feedback may provide data to adjust the patient's estimated goal settings 10820. For example, a patient's upper airway may, over time, undergo muscle remodeling such that less stimulation than originally estimated provides efficacious therapy. Alternatively, a patient may gain weight such that more stimulation than originally estimated may be needed to provide efficacious therapy.

If the stimulation is causing discomfort to the patient such that stimulation disrupts sleep or inhibits falling asleep with stimulation on, many options are available, 10830. Stimulation may be reduced and the patient may be given more time for nighttime familiarization. A different strategy that may increase the therapy provided to the patient is to utilize the device features of core hours, soft start, retention intensity, and nested stimulation. The core hours feature (FIG. 6K) allows the patient to fall asleep at one level of stimulation and after a programmable time interval, have stimulation increased to a more therapeutic level. Patients are often able to tolerate higher stimulations when asleep compared to wakefulness and in addition, tolerate higher stimulations further into a therapy session than at the start of a session.

As mentioned previously, the INS 1100 may be programmed to change stimulation level between therapy sessions, days, or other programmable value, enabling comparisons between stimulation level and therapy session data. For example, the INS 1100 may be programmed to alternate between 1.8 mA and 2.0 mA, where the change occurs between therapy sessions. This may be used as a diagnostic mode to assess the incremental benefit of the higher stimulation level. A patient receiving daily therapy would thus receive therapy at 1.8 mA on one day, 2.0 mA the next, 1.8 mA the next day, 2.0 mA the next day, and so on. This may allow therapy session data to be compared with stimulation level. For example, a physician may compare the cycling rate (via the cycling detector) during therapy sessions at 1.8 mA and 2.0 mA over time to determine if there is an observable difference. If cycling is reduced at 2.0 mA, the physician may increase stimulation and re-test. If there was no observable difference, the physician may decrease stimulation and re-test or simply set stimulation to the lower level. This may reduce the likelihood of delivering stimulation at

a level that, compared to a lower level, provides no additional flow or no additional benefit. As mentioned previously, other therapy session data may be compared to stimulation level as well in a similar manner. Examples of other therapy session data are: oxygen desaturation frequency and severity, stimulation time, variations in respiratory rate, and variations in respiratory prediction.

Various pulse configurations may also help a patient acclimate to stimulation. The soft start stimulations (FIG. 6G) may provide a smoother transition from unstimulated breaths to stimulated breaths, reducing the patient's perception of stimulation intensity. Retention intensity (FIGS. 6E and 6F) may also provide therapy with reduced patient perception of stimulation intensity, since the full amplitude is only used for a part of the stimulation. Nested stimulations (FIG. 6H) may be used in a similar manner.

The patient may use positive airway pressure (PAP) therapy (e.g., CPAP, bi-PAP, auto-PAP, etc.) in conjunction with the neurostimulator. This may allow the patient to receive therapeutic benefits in addition to what is provided by the stimulation. The pressure necessary to provide these benefits may decrease as stimulation is up-titrated, 10800. This progress towards lower pressures may be monitored using the auto-PAP technology which automatically adjusts pressure to the level necessary to remove flow limitation. In time, the patient may wish to stop PAP therapy altogether. In a similar manner, other therapies such as but not limited to positional therapy and mandibular advancement may be used in conjunction with the neurostimulator.

If the patient begins noticing tongue abrasions, a tooth guard or other tooth covering (e.g. dental wax) may be used such that the tongue does not scrape against the teeth when stimulation causes tongue protrusion. Tooth guards may be custom-made (e.g., by a dentist).

Additional strategies for acclimation may include another sleep titration night to examine different stimulation frequencies, pulse widths, and modes, as previously described. Different stimulation frequencies and pulse widths may capture different muscle groups in a more therapeutic manner. In additions, respiration vectors may need to be assessed during a vector sweeping titration.

Therapy efficacy may be measured using standard PSG techniques during and after familiarization and up-titration. Therapy efficacy may be evaluated by assessing indicia of sleep disordered breathing such as AHI, apnea index, hypopnea index, respiratory disturbance index, apnea-hypopnea index, ODI, FOSQ, ESS, BDI, PSQI, or other measures.

Alternative Embodiments

The stimulation may be delivered to the nerve by utilizing a variety of stimulation electrode configurations, in addition to the configurations previously mentioned.

Mono-polar stimulation may be delivered to the nerve wherein the cathode (or multiple cathodes) is an electrode (or multiple electrodes) in the STL nerve cuff 1350, and wherein the anode is the INS 1100. Similarly, far-field bi-polar stimulation may be delivered to the nerve wherein the cathode (or multiple cathodes) is an electrode (or multiple electrodes) in the nerve cuff, and wherein the anode is an RSL electrode 1250 or 1260.

Any combination of bi-polar and mono-polar stimulation may be utilized to deliver stimulation to the nerve. For example, mono-polar stimulation may be delivered between a cathode electrode in the STL nerve cuff 1350 and the INS 1100 anode. Simultaneously, far-field bi-polar stimulation

may be delivered between a different cathode electrode in the STL nerve cuff 1350 and an RSL electrode 1250 or 1260 anode.

The INS 1100 may be programmed to periodically change stimulation parameters throughout a therapy session to vary which muscle fibers are recruited at any given time. For example, stimulation may be delivered at an initial lower frequency (e.g. 30 Hz) for 5 minutes, followed by stimulation delivered at a higher frequency (e.g. 50 Hz) for 2 minutes. Each frequency may have a unique pulse width, pulse width, and/or amplitude. This sequence could be repeated throughout the night.

This may allow certain muscle fibers to rest during periods when other muscle fibers are active. This may reduce muscle fatigue. Another potential advantage is that stimulation at more than a single frequency and/or pulse width may be a more effective means of building muscle strength and endurance. Another potential advantage is that different stimulation settings (e.g. frequency, pulse width, and/or amplitude) may result in slightly different movement of the tongue. Varying stimulation settings may decrease the possibility of repetition-induced irritation, inflammation or injury.

Alternatively, it may be possible to effectively build muscle strength and endurance by deactivating a portion of the nerve fibers and activating a remaining subset of fibers. This may allow delivery of higher levels of stimulation to the remaining fibers. This may reduce subject discomfort which could have occurred if all the fibers had been activated at that same intensity. Additionally, this may increase airway patency or opening by selecting muscles whose activation results in tongue protrusion and deactivating tongue retrusion muscles.

Certain fibers in the nerve may be selectively deactivated by choosing the cathode of pulse delivery and sequence of pulse delivery such that the fibers are not recruited by subsequent or simultaneous pulses. For example, a nerve fiber that innervates a retrusor muscle may be deactivated by delivering a sub-threshold pulse from a nearby cathode. This may allow a subsequent or simultaneous pulse at a different cathode to activate a nerve protrusor muscle nerve fiber without recruiting the retrusor muscle.

What is claimed is:

1. A method of delivering a nerve stimulation therapy to a subject via an implanted neurostimulator connected to a stimulation delivery lead, the method comprising:

delivering the nerve stimulation therapy at a first intensity during a first therapy period of the nerve stimulation therapy, wherein the first intensity is within a range having a lower bound and an upper bound, wherein the subject is awake during at least an initial portion of the first therapy period, and wherein the upper bound is a discomfort threshold; and

delivering the nerve stimulation therapy at a second intensity during a second therapy period of the nerve stimulation therapy subsequent to the first therapy period, wherein the second intensity is different from the first intensity, wherein the subject is asleep during at least an initial portion of the second therapy period, wherein the nerve stimulation therapy is delivered to a nerve for treating a respiratory condition of the subject.

2. The method of claim 1, wherein the first therapy period is a programmed interval.

3. The method of claim 1, wherein a timing of an initiation of the second therapy period is selected before an initiation of the first therapy period.

4. The method of claim 1, wherein an initiation of the second therapy period is based on and/or responsive to at least one of a fixed duration of time, a number of breaths, a number of stimulations delivered during the first therapy period, an interval assigned to the first therapy period, and a detection of subject activity.

5. The method of claim 1, wherein the second intensity is greater than the first intensity.

6. The method of claim 5, wherein the second intensity is greater than the discomfort threshold.

7. The method of claim 1, wherein the second therapy period is consecutive to the first therapy period.

8. The method of claim 1, further comprising:

delivering the nerve stimulation therapy at an increasing level of intensity prior to the first therapy period, the increasing level of intensity maximizing at the first intensity.

9. The method of claim 1, wherein the first intensity is interposed with at least one of an additional intensity and a non-stimulating intensity of the first therapy period to define a therapy mode.

10. The method of claim 9, wherein each delivery of the first intensity is asynchronous with respiration.

11. The method of claim 9, wherein the therapy mode is at least one of an ABAB mode, an AOA mode, an AABB mode, an xABO mode, an xAOB mode, and an xAB mode.

12. The method of claim 11, wherein each delivery of the first intensity is asynchronous with respiration.

13. The method of claim 1, wherein the second intensity is interposed with at least one of an additional intensity and a non-stimulating intensity of the second therapy period to define a therapy mode.

14. The method of claim 13, wherein each delivery of the second intensity is asynchronous with respiration.

15. The method of claim 13, wherein the therapy mode is at least one of an ABAB mode, an AOA mode, an AABB mode, an xABO mode, an xAOB mode, and an xAB mode.

16. The method of claim 15, wherein each delivery of the second intensity is asynchronous with respiration.

17. The method of claim 1, wherein at least one of the first intensity and the second intensity is an amplitude of a current pulse.

18. The method of claim 1, wherein the discomfort threshold is defined while the subject is awake.

19. The method of claim 1, wherein the implanted neurostimulator includes at least one algorithm configured to provide:

a first capability to program the neurostimulator to deliver the first intensity during the first therapy period; and
a second capability to program the neurostimulator to deliver the second intensity during the second therapy period.

20. The method of claim 1, wherein the nerve is a hypoglossal nerve, and the respiratory condition is sleep apnea.

21. A method of delivering a nerve stimulation therapy to a subject via an implanted neurostimulator connected to a stimulation delivery lead, the method comprising:

delivering the nerve stimulation therapy at a first intensity during a first therapy period of the therapy, wherein the first intensity is within a range having a lower bound and an upper bound wherein the subject is awake during at least an initial portion of the first therapy period, and wherein the upper bound is a discomfort threshold;

transitioning from the first therapy period to a second therapy period of the nerve stimulation therapy subse-

37

quent to the first therapy period, the transitioning comprising a cessation of stimulation; and delivering the nerve stimulation therapy at a second intensity during the second therapy period, wherein the second intensity is greater than the first intensity and the discomfort threshold wherein the subject is asleep during at least an initial portion of the second therapy period, wherein the nerve stimulation therapy is delivered to a nerve for treating a respiratory condition of the subject.

22. The method of claim 21, wherein the cessation of stimulation is due to subject action.

23. The method of claim 22, wherein the subject action is the initiation of a pre-set number of pauses.

24. The method of claim 21, wherein the second intensity is a product of a subject adjustment of the first intensity.

25. The method of claim 24, wherein the subject adjustment of the first intensity is limited to a pre-programmed range of second intensities.

26. The method of claim 21, further comprising: delivering the nerve stimulation therapy at an increasing level of intensity between the cessation of stimulation and the second therapy period.

27. The method of claim 21, wherein the cessation of stimulation is prompted by a signal received from a sensor.

28. The method of claim 21, wherein at least one of the first intensity and the second intensity is an amplitude of a current pulse.

29. The method of claim 21, wherein the discomfort threshold is defined while the subject is awake.

38

30. The method of claim 21, wherein the implanted neurostimulator includes at least one algorithm configured to provide:

- a first capability to program the neurostimulator to deliver the first intensity during the first therapy period; and
- a second capability to program the neurostimulator to deliver the second intensity during the second therapy period.

31. A method of delivering a nerve stimulation therapy to a subject via an implanted neurostimulator connected to a stimulation delivery lead, the method comprising:

- delivering the nerve stimulation therapy at a first intensity during a first therapy period of the nerve stimulation therapy, wherein the first intensity is within a range having a lower bound and an upper bound, wherein the subject is awake during at least an initial portion of the first therapy period, and wherein the upper bound is a threshold determined based on feedback from the subject; and

- delivering the nerve stimulation therapy at a second intensity during a second therapy period of the nerve stimulation therapy subsequent to the first therapy period, wherein the second intensity is different from the first intensity, and wherein the subject is asleep during at least an initial portion of the second therapy period,

wherein the nerve stimulation therapy is delivered to a nerve for treating a respiratory condition of the subject.

* * * * *

专利名称(译)	阻塞性睡眠呼吸暂停治疗装置，系统和方法		
公开(公告)号	US9913982	公开(公告)日	2018-03-13
申请号	US13/106460	申请日	2011-05-12
[标]申请(专利权)人(译)	APNEX医疗		
申请(专利权)人(译)	APNEX MEDICAL , INC.		
当前申请(专利权)人(译)	Cyberonics公司 , INC.		
[标]发明人	BOLEA STEPHEN L HOEGH THOMAS B KUHNLEY BRIAN D SUILMANN DALE G PERSSON BRUCE J BECK JOHN P HAUSCHILD SIDNEY F TEFAYESUS WONDIMENEH SKUBITZ JASON J BOSSHARD MARK R PARRISH DANIEL A ATKINSON ROBERT E		
发明人	BOLEA, STEPHEN L. HOEGH, THOMAS B. KUHNLEY, BRIAN D. SUILMANN, DALE G. PERSSON, BRUCE J. BECK, JOHN P. HAUSCHILD, SIDNEY F. TEFAYESUS, WONDIMENEH SKUBITZ, JASON J. BOSSHARD, MARK R. PARRISH, DANIEL A. ATKINSON, ROBERT E.		
IPC分类号	A61N1/00 A61N1/36 A61N1/05 A61N1/372 A61B5/08 A61B5/00		
CPC分类号	A61N1/3601 A61N1/0556 A61N1/3611 A61N1/3615 A61N1/37235 A61N1/36139 A61N1/36132 A61B5/0809 A61B5/0826 A61B5/4818		
代理机构(译)	FOLEY & Lardner的律师事务所		
优先权	61/437573 2011-01-28 US		
其他公开文献	US20120192874A1		
外部链接	Espacenet USPTO		

摘要(译)

用于治疗阻塞性睡眠呼吸暂停的神经刺激的装置，系统和方法。该系统适于基于来自呼吸感测引线的输入，在呼吸周期的适当阶段通过刺激导管将植入的神经刺激器的电信号发送到患者的神经。外部组件适于与神经刺激器进行无线通信。神经刺激器适于基于输入提供治疗刺激。

