



US009901714B2

(12) **United States Patent**  
**Lemon et al.**

(10) **Patent No.:** **US 9,901,714 B2**  
(45) **Date of Patent:** **Feb. 27, 2018**

(54) **CATHETER ASSEMBLY INCLUDING ECG SENSOR AND MAGNETIC ASSEMBLIES**

(75) Inventors: **Ryan R. Lemon**, Sandy, UT (US);  
**Matthew W. Bown**, West Bountiful, UT (US)

(73) Assignee: **C. R. Bard, Inc.**, Murray Hill, NJ (US)

(\* ) Notice: Subject to any disclaimer, the term of this patent is extended or adjusted under 35 U.S.C. 154(b) by 1289 days.

(21) Appl. No.: **12/545,762**

(22) Filed: **Aug. 21, 2009**

(65) **Prior Publication Data**

US 2010/0222664 A1 Sep. 2, 2010

**Related U.S. Application Data**

(60) Provisional application No. 61/091,233, filed on Aug. 22, 2008, provisional application No. 61/095,451, filed on Sep. 9, 2008.

(51) **Int. Cl.**  
*A61B 5/00* (2006.01)  
*A61M 25/09* (2006.01)  
(Continued)

(52) **U.S. Cl.**  
CPC ..... *A61M 25/09* (2013.01); *A61B 5/042* (2013.01); *A61M 25/0102* (2013.01);  
(Continued)

(58) **Field of Classification Search**  
CPC ..... A61M 25/0102  
(Continued)

(56) **References Cited**

U.S. PATENT DOCUMENTS

3,133,244 A 5/1964 Wojtulewicz  
3,297,020 A 1/1967 Mathiesen  
(Continued)

FOREIGN PATENT DOCUMENTS

AU 642647 11/1990  
AU 5586590 11/1990  
(Continued)

OTHER PUBLICATIONS

“Ascension to Launch New 3D Guidance198 Tracker at TCT 2006.”  
Press Releases from Ascension website: [www.ascension-tech.com/news/press\\_101106.php](http://www.ascension-tech.com/news/press_101106.php).

(Continued)

*Primary Examiner* — Joseph M Santos Rodriguez  
(74) *Attorney, Agent, or Firm* — Rutan & Tucker, LLP

(57) **ABSTRACT**

A stylet for use in guiding a distal tip of a catheter to a predetermined location within the body of a patient. In one embodiment the stylet is configured for use within a lumen of the catheter and comprises a core wire, an ECG sensor, and a magnetic assembly. The ECG sensor senses an ECG signal of a patient when the stylet is disposed within the lumen of the catheter and the catheter is disposed within the body of the patient. The magnetic assembly includes at least one element capable of producing a magnetic or electro-magnetic field for detection by a sensor external to the patient. In another embodiment, the stylet includes a pre-shaped distal segment that is deflected with respect to a more proximal portion of the stylet, which in turn causes a distal segment of the catheter to be deflected when the stylet is received within the lumen.

**20 Claims, 13 Drawing Sheets**

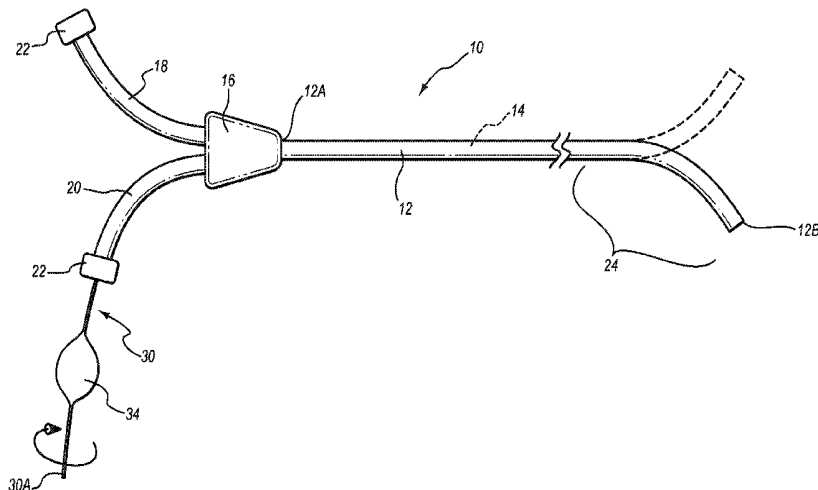

(51)	<b>Int. Cl.</b>		4,665,925 A	5/1987	Millar
	<i>A61B 5/042</i>	(2006.01)	4,667,230 A	5/1987	Arakawa et al.
	<i>A61M 25/01</i>	(2006.01)	4,674,518 A	6/1987	Salo et al.
	<i>A61B 17/00</i>	(2006.01)	4,676,249 A	6/1987	Arenas et al.
	<i>A61M 25/00</i>	(2006.01)	4,681,106 A	7/1987	Kensey et al.
	<i>A61B 34/20</i>	(2016.01)	4,681,117 A	7/1987	Brodman et al.
			4,688,578 A	8/1987	Takano et al.
(52)	<b>U.S. Cl.</b>		4,692,148 A	9/1987	Kantrowitz et al.
	CPC .....	<i>A61B 2017/00044</i> (2013.01); <i>A61B</i>	4,697,595 A	10/1987	Breyer et al.
		<i>2017/00331</i> (2013.01); <i>A61B 2034/2051</i>	4,700,997 A	10/1987	Strand
		(2016.02); <i>A61M 25/0054</i> (2013.01); <i>A61M</i>	4,706,681 A	11/1987	Breyer et al.
		<i>2025/09116</i> (2013.01); <i>A61M 2025/09141</i>	4,710,708 A	12/1987	Rorden et al.
		(2013.01); <i>A61M 2025/09175</i> (2013.01);	4,733,669 A	3/1988	Segal
		<i>A61M 2025/09183</i> (2013.01); <i>A61M</i>	4,737,794 A	4/1988	Jones
		<i>2205/3507</i> (2013.01)	4,741,356 A	5/1988	Letzo et al.
			4,742,356 A	5/1988	Kuipers
			4,753,247 A	6/1988	Kirsner et al.
(58)	<b>Field of Classification Search</b>		4,770,185 A	9/1988	Silverstein et al.
	USPC .....	600/372-374, 395, 40, 424-428,	4,771,788 A	9/1988	Millar
		600/433-435, 508-509	4,781,685 A	11/1988	Lehmann et al.
	See application file for complete search history.		4,784,646 A	11/1988	Feingold
			4,787,070 A	11/1988	Suzuki et al.
			4,787,396 A	11/1988	Pidorenko
(56)	<b>References Cited</b>		4,790,809 A	12/1988	Kuntz
	<b>U.S. PATENT DOCUMENTS</b>		4,793,361 A	12/1988	DuFault
			4,794,930 A	1/1989	Machida et al.
			4,796,632 A	1/1989	Boyd et al.
			4,798,588 A	1/1989	Aillon
			4,798,598 A	1/1989	Bonello et al.
			4,809,681 A	3/1989	Kantrowitz et al.
			4,809,713 A	3/1989	Grayzel
			4,813,729 A	3/1989	Speckhart
			4,821,731 A	4/1989	Martinelli et al.
			4,836,214 A	6/1989	Sramek
			4,840,182 A	6/1989	Carlson
			4,840,622 A	6/1989	Hardy
			4,841,977 A	6/1989	Griffith et al.
			4,849,692 A	7/1989	Blood
			4,850,358 A	7/1989	Millar
			4,852,580 A	8/1989	Wood
			4,856,317 A	8/1989	Pidorenko et al.
			4,856,529 A	8/1989	Segal
			4,860,757 A	8/1989	Lynch et al.
			4,867,169 A	9/1989	Machida et al.
			4,869,263 A	9/1989	Segal et al.
			4,869,718 A	9/1989	Brader
			4,873,987 A	10/1989	Djordjevich et al.
			4,887,606 A	12/1989	Yock et al.
			4,887,615 A	12/1989	Taylor
			4,889,128 A	12/1989	Millar
			4,899,756 A	2/1990	Sonek
			4,901,725 A	2/1990	Nappholz et al.
			4,905,698 A	3/1990	Strohl, Jr. et al.
			4,911,173 A	3/1990	Terwilliger
			4,911,174 A	3/1990	Pederson et al.
			4,917,669 A	4/1990	Bonaldo
			4,924,870 A	5/1990	Wlodarczyk et al.
			4,943,770 A	7/1990	Ashley-Rollman et al.
			4,945,305 A	7/1990	Blood
			4,947,852 A	8/1990	Nassi et al.
			4,957,110 A	9/1990	Vogel et al.
			4,957,111 A	9/1990	Millar
			4,961,433 A	10/1990	Christian
			4,966,148 A	10/1990	Millar
			4,967,753 A	11/1990	Haase et al.
			4,977,886 A	12/1990	Takehana et al.
			4,989,608 A	2/1991	Ratner
			4,989,610 A	2/1991	Patton et al.
			4,995,396 A	2/1991	Inaba et al.
			4,998,916 A	3/1991	Hammerslag et al.
			5,004,456 A	4/1991	Botterbusch et al.
			5,005,592 A	4/1991	Cartmell
			5,016,173 A	5/1991	Kenet et al.
			5,025,799 A	6/1991	Wilson
			5,029,585 A	7/1991	Lieber et al.
			5,040,548 A	8/1991	Yock
			5,042,486 A	8/1991	Pfeiler et al.
			5,045,071 A	9/1991	McCormick et al.
			5,046,497 A	9/1991	Millar

(56)

## References Cited

## U.S. PATENT DOCUMENTS

5,050,607 A	9/1991	Bradley et al.	5,331,966 A	7/1994	Bennett et al.
5,057,095 A	10/1991	Fabian	5,333,614 A	8/1994	Feiring
5,058,583 A	10/1991	Geddes et al.	5,337,678 A	8/1994	Grout et al.
5,058,595 A	10/1991	Kern	5,341,807 A	8/1994	Nardella
5,067,489 A	11/1991	Lind	5,343,865 A	9/1994	Gardineer et al.
5,076,278 A	12/1991	Vilkomerson et al.	5,345,940 A	9/1994	Seward et al.
5,078,140 A	1/1992	Kwoh	5,348,020 A	9/1994	Hutson
5,078,148 A	1/1992	Nassi et al.	5,350,352 A	9/1994	Buchholtz et al.
5,078,149 A	1/1992	Katsumata et al.	5,357,961 A	10/1994	Fields et al.
5,078,678 A	1/1992	Katims	5,365,935 A	11/1994	Righter et al.
5,078,714 A	1/1992	Katims	5,366,443 A	11/1994	Eggers et al.
5,084,022 A	1/1992	Claude	5,368,048 A	11/1994	Stoy et al.
5,092,341 A	3/1992	Kelen	5,375,596 A	12/1994	Twiss et al.
5,099,845 A	3/1992	Besz et al.	5,376,083 A	12/1994	Mische
5,099,850 A	3/1992	Matsui et al.	5,377,678 A	1/1995	Dumoulin et al.
5,100,387 A	3/1992	Ng	5,385,053 A	1/1995	Wlodarczyk et al.
5,105,829 A	4/1992	Fabian et al.	5,385,146 A	1/1995	Goldreyer
5,109,862 A	5/1992	Kelen et al.	5,391,199 A	2/1995	Ben-Haim
5,114,401 A	5/1992	Stuart et al.	5,394,876 A	3/1995	Ma
5,121,750 A	6/1992	Katims	5,394,877 A	3/1995	Orr et al.
5,122,538 A	6/1992	Lokkesmoe et al.	5,395,366 A	3/1995	D'Andrea et al.
5,125,410 A	6/1992	Misono et al.	5,398,683 A	3/1995	Edwards et al.
5,134,370 A	7/1992	Jefferts et al.	5,398,691 A	3/1995	Martin et al.
5,144,955 A	9/1992	O'Hara	5,411,485 A	5/1995	Tennican et al.
5,156,151 A	10/1992	Imran	5,413,107 A	5/1995	Oakley et al.
5,158,086 A	10/1992	Brown et al.	5,417,208 A	5/1995	Winkler
5,160,342 A	11/1992	Reger et al.	5,417,701 A	5/1995	Holmes
5,161,536 A	11/1992	Vilkomerson et al.	5,422,478 A	6/1995	Wlodarczyk et al.
5,174,295 A	12/1992	Christian et al.	5,423,334 A	6/1995	Jordan
5,174,299 A	12/1992	Nelson	5,423,877 A	6/1995	MacKey
5,184,601 A	2/1993	Putman	5,425,367 A	6/1995	Shapiro et al.
5,190,045 A	3/1993	Frazin	5,425,370 A	6/1995	Vilkomerson
5,202,985 A	4/1993	Goyal	5,425,382 A	6/1995	Golden et al.
5,205,830 A	4/1993	Dassa et al.	5,427,114 A	6/1995	Colliver et al.
5,211,165 A	5/1993	Dumoulin et al.	5,429,132 A	7/1995	Guy et al.
5,211,636 A	5/1993	Mische	5,429,617 A	7/1995	Hammersmark et al.
5,212,988 A	5/1993	White et al.	5,431,641 A	7/1995	Grozinger et al.
5,214,615 A	5/1993	Bauer et al.	5,433,729 A	7/1995	Adams et al.
5,217,026 A	6/1993	Stoy et al.	5,437,276 A	8/1995	Takada et al.
5,220,924 A	6/1993	Frazin	5,437,277 A	8/1995	Dumoulin et al.
5,233,994 A	8/1993	Shmulewitz	5,438,873 A	8/1995	Marek et al.
5,235,987 A	8/1993	Wolfe	5,443,066 A	8/1995	Dumoulin et al.
5,239,464 A	8/1993	Blair et al.	5,443,489 A	8/1995	Ben-Haim
5,240,004 A	8/1993	Walinsky et al.	5,445,150 A	8/1995	Dumoulin et al.
5,243,995 A	9/1993	Maier	5,445,166 A	8/1995	Taylor
5,246,007 A	9/1993	Frisbie et al.	5,450,846 A	9/1995	Goldreyer
5,246,426 A	9/1993	Lewis et al.	5,453,575 A	9/1995	O'Donnell et al.
5,247,171 A	9/1993	Wlodarczyk et al.	5,453,576 A	9/1995	Krivitski
5,251,635 A	10/1993	Dumoulin et al.	5,456,256 A	10/1995	Schneider et al.
5,255,680 A	10/1993	Darrow et al.	5,456,718 A	10/1995	Szymaitis
5,257,636 A	11/1993	White	5,464,016 A	11/1995	Nicholas et al.
5,257,979 A	11/1993	Jagpal	5,474,065 A	12/1995	Meathrel et al.
5,261,409 A	11/1993	Dardel	5,476,090 A	12/1995	Kishi et al.
5,265,610 A	11/1993	Darrow et al.	5,480,422 A	1/1996	Ben-Haim
5,265,614 A	11/1993	Hayakawa et al.	5,487,729 A	1/1996	Avellanet et al.
5,267,569 A	12/1993	Lienhard	5,490,522 A	2/1996	Dardel
5,270,810 A	12/1993	Shigeru et al.	5,492,538 A	2/1996	Johlin, Jr.
5,271,404 A	12/1993	Corl et al.	5,494,038 A	2/1996	Wang et al.
5,273,025 A	12/1993	Sakiyama et al.	5,500,011 A	3/1996	Desai
5,273,042 A	12/1993	Lynch et al.	5,500,012 A	3/1996	Brucker et al.
5,274,551 A	12/1993	Corby, Jr.	5,505,205 A	4/1996	Solomon et al.
5,275,053 A	1/1994	Wlodarczyk et al.	5,509,822 A	4/1996	Negus et al.
5,279,129 A	1/1994	Ito	5,513,637 A	5/1996	Twiss et al.
5,279,607 A	1/1994	Schentag et al.	5,515,160 A	5/1996	Schulz et al.
5,280,786 A	1/1994	Wlodarczyk et al.	5,515,853 A	5/1996	Smith et al.
5,287,331 A	2/1994	Schindel et al.	5,517,989 A	5/1996	Frisbie et al.
5,289,373 A	2/1994	Zarge et al.	5,522,878 A	6/1996	Montecalvo et al.
5,292,342 A	3/1994	Nelson et al.	5,522,880 A	6/1996	Barone et al.
5,307,072 A	4/1994	Jones, Jr.	5,526,812 A	6/1996	Dumoulin et al.
5,311,871 A	5/1994	Yock	5,531,664 A	7/1996	Adachi et al.
5,313,949 A	5/1994	Yock	5,536,248 A	7/1996	Weaver et al.
5,318,025 A	6/1994	Dumoulin et al.	5,540,230 A	7/1996	Vilkomerson
5,325,860 A	7/1994	Seward et al.	5,540,681 A	7/1996	Strul et al.
5,325,873 A	7/1994	Hirschi et al.	5,542,938 A	8/1996	Avellanet et al.
5,330,496 A	7/1994	Alferness	5,546,949 A	8/1996	Frazin et al.
			5,546,951 A	8/1996	Ben-Haim
			5,555,618 A	9/1996	Winkler
			5,558,091 A	9/1996	Acker et al.
			5,568,809 A	10/1996	Ben-haim

(56)

## References Cited

## U.S. PATENT DOCUMENTS

D375,450 S	11/1996	Bidwell et al.	5,769,786 A	6/1998	Wiegel
5,570,671 A	11/1996	Hickey	5,769,843 A	6/1998	Abela et al.
5,575,291 A	11/1996	Hayakawa et al.	5,769,881 A	6/1998	Schroepffel et al.
5,588,442 A	12/1996	Scovil et al.	5,771,896 A	6/1998	Sliwa, Jr. et al.
5,592,939 A	1/1997	Martinelli	5,775,322 A	7/1998	Silverstein et al.
5,598,846 A	2/1997	Peszynski et al.	5,775,332 A	7/1998	Goldman
5,599,299 A	2/1997	Weaver et al.	5,776,064 A	7/1998	Kalfas et al.
5,600,330 A	2/1997	Blood	5,776,080 A	7/1998	Thome et al.
5,603,333 A	2/1997	Konings	5,779,638 A	7/1998	Vesely et al.
5,610,967 A	3/1997	Moorman et al.	5,782,767 A	7/1998	Pretlow
5,617,866 A	4/1997	Marian, Jr.	5,782,773 A	7/1998	Kuo et al.
5,622,169 A	4/1997	Golden et al.	5,785,657 A	7/1998	Breyer et al.
5,622,170 A	4/1997	Schulz	5,792,055 A	8/1998	McKinnon et al.
5,622,184 A	4/1997	Ashby et al.	5,795,297 A	8/1998	Daigle
5,623,931 A	4/1997	Wung et al.	5,795,298 A	8/1998	Vesely et al.
5,624,430 A	4/1997	Eton et al.	5,795,632 A	8/1998	Buchalter
5,626,554 A	5/1997	Ryaby et al.	5,797,849 A	8/1998	Vesely et al.
5,626,870 A	5/1997	Monshipouri et al.	5,800,352 A	9/1998	Ferre et al.
5,630,419 A	5/1997	Ranalletta	5,800,410 A	9/1998	Gawreluk
5,638,819 A	6/1997	Manwaring et al.	5,800,497 A	9/1998	Bakels et al.
5,644,612 A	7/1997	Moorman et al.	5,803,089 A	9/1998	Ferre et al.
5,645,065 A	7/1997	Shapiro et al.	5,810,733 A	9/1998	Van Creveld et al.
5,651,047 A	7/1997	Moorman et al.	RE35,924 E	10/1998	Winkler
5,654,864 A	8/1997	Ritter et al.	5,817,022 A	10/1998	Vesely
D383,968 S	9/1997	Bidwell et al.	5,817,024 A	10/1998	Ogle et al.
5,662,115 A	9/1997	Toro et al.	5,820,549 A	10/1998	Marian, Jr.
5,665,103 A	9/1997	Lafontaine et al.	5,824,031 A	10/1998	Cookston et al.
5,665,477 A	9/1997	Meathrel et al.	5,827,192 A	10/1998	Gopakumaran et al.
5,666,473 A	9/1997	Wallace	5,829,444 A	11/1998	Ferre et al.
5,666,958 A	9/1997	Rothenberg et al.	5,830,145 A	11/1998	Tenhoff
5,669,383 A	9/1997	Johnson	5,831,260 A	11/1998	Hansen
5,669,388 A	9/1997	Vilkomerson	5,833,608 A	11/1998	Acker
5,676,159 A	10/1997	Navis	5,833,622 A	11/1998	Meathrel et al.
5,676,673 A	10/1997	Ferre et al.	5,835,561 A	11/1998	Moorman et al.
5,682,890 A	11/1997	Kormos et al.	5,836,882 A	11/1998	Frazin
5,691,898 A	11/1997	Rosenberg et al.	5,836,990 A	11/1998	Li
5,694,945 A	12/1997	Ben-Haim	5,840,024 A	11/1998	Taniguchi et al.
5,695,479 A	12/1997	Jagpal	5,840,025 A	11/1998	Ben-Haim
5,697,377 A	12/1997	Wittkampf	5,840,030 A	11/1998	Ferek-Petric et al.
5,699,801 A	12/1997	Atalar et al.	5,840,031 A	11/1998	Crowley
5,700,889 A	12/1997	Blair	5,842,986 A	12/1998	Avrin et al.
5,701,898 A	12/1997	Adam et al.	5,842,998 A	12/1998	Gopakumaran et al.
5,702,433 A	12/1997	Taylor et al.	5,843,076 A	12/1998	Webster, Jr. et al.
5,711,299 A	1/1998	Manwaring et al.	5,843,153 A	12/1998	Johnston et al.
5,713,362 A	2/1998	Vilkomerson	5,844,140 A	12/1998	Seale
5,713,363 A	2/1998	Seward et al.	5,846,198 A	12/1998	Killmann
5,713,858 A	2/1998	Heruth et al.	5,855,553 A	1/1999	Tajima et al.
5,713,946 A	2/1998	Ben-Haim	5,859,893 A	1/1999	Moorman et al.
5,715,817 A	2/1998	Stevens-Wright et al.	5,865,748 A	2/1999	Co et al.
5,716,389 A	2/1998	Walinsky et al.	5,868,673 A	2/1999	Vesely
5,718,241 A	2/1998	Ben-Haim et al.	5,873,822 A	2/1999	Ferre et al.
D391,838 S	3/1998	Bidwell et al.	5,876,328 A	3/1999	Fox et al.
5,722,412 A	3/1998	Pflugrath et al.	5,879,297 A	3/1999	Haynor et al.
5,727,550 A	3/1998	Montecalvo	5,893,363 A	4/1999	Little et al.
5,727,552 A	3/1998	Ryan	5,897,495 A	4/1999	Aida et al.
5,727,553 A	3/1998	Saad	5,899,860 A	5/1999	Pfeiffer et al.
5,729,055 A	3/1998	Manning	5,902,238 A	5/1999	Golden et al.
5,729,129 A	3/1998	Acker	5,907,487 A	5/1999	Rosenberg et al.
5,729,584 A	3/1998	Moorman et al.	5,908,385 A	6/1999	Czechelski et al.
5,730,129 A	3/1998	Darrow et al.	5,910,113 A	6/1999	Pruter
5,731,996 A	3/1998	Gilbert	5,910,120 A	6/1999	Kim et al.
5,733,323 A	3/1998	Buck et al.	5,913,820 A	6/1999	Bladen et al.
5,738,096 A	4/1998	Ben-Haim	5,913,830 A	6/1999	Miles
5,740,808 A	4/1998	Panescu et al.	5,919,141 A	7/1999	Money et al.
5,742,394 A	4/1998	Hansen	5,919,170 A	7/1999	Woessner
5,744,953 A	4/1998	Hansen	5,928,145 A	7/1999	Ocali et al.
5,748,767 A	5/1998	Raab	5,929,607 A	7/1999	Rosenberg et al.
5,749,835 A	5/1998	Glantz	5,931,788 A	8/1999	Keen et al.
5,749,938 A	5/1998	Coombs	5,931,818 A	8/1999	Werp et al.
5,751,785 A	5/1998	Moorman et al.	5,931,863 A	8/1999	Griffin, III et al.
5,752,513 A	5/1998	Acker et al.	5,941,858 A	8/1999	Johnson
5,758,650 A	6/1998	Miller et al.	5,941,889 A	8/1999	Cermak
5,762,064 A	6/1998	Polvani	5,941,904 A	8/1999	Johnston et al.
5,767,669 A	6/1998	Hansen et al.	5,944,022 A	8/1999	Nardella et al.
5,767,960 A	6/1998	Orman et al.	5,944,023 A	8/1999	Johnson et al.
			5,951,598 A	9/1999	Bishay et al.
			5,953,683 A	9/1999	Hansen et al.
			5,957,857 A	9/1999	Hartley
			5,961,923 A	10/1999	Nova et al.

(56)

## References Cited

## U.S. PATENT DOCUMENTS

5,967,978 A	10/1999	Littmann et al.	6,191,136 B1	2/2001	Marban
5,967,980 A	10/1999	Ferre et al.	6,193,743 B1	2/2001	Brayton et al.
5,967,991 A	10/1999	Gardineer et al.	6,197,001 B1	3/2001	Wilson et al.
5,969,722 A	10/1999	Palm	6,200,305 B1	3/2001	Berthiaume et al.
5,971,933 A	10/1999	Gopakumaran et al.	6,203,499 B1	3/2001	Imling et al.
5,978,705 A	11/1999	KenKnight et al.	6,208,884 B1	3/2001	Kumar et al.
5,983,126 A	11/1999	Wittkamp	6,211,626 B1	4/2001	Lys et al.
5,984,908 A	11/1999	Davis et al.	6,211,666 B1	4/2001	Acker
5,991,693 A	11/1999	Zalewski	6,212,426 B1	4/2001	Swanson
5,997,473 A	12/1999	Taniguchi et al.	6,216,027 B1	4/2001	Willis et al.
5,997,481 A	12/1999	Adams et al.	6,216,028 B1	4/2001	Haynor et al.
6,006,123 A	12/1999	Nguyen et al.	6,216,029 B1	4/2001	Paltieli
6,011,988 A	1/2000	Lynch et al.	6,223,087 B1	4/2001	Williams
6,014,473 A	1/2000	Hossack et al.	6,226,547 B1	5/2001	Lockhart et al.
6,014,580 A	1/2000	Blume et al.	6,230,042 B1	5/2001	Slettenmark
6,015,414 A	1/2000	Werp et al.	6,230,046 B1	5/2001	Crane et al.
6,017,496 A	1/2000	Nova et al.	6,231,518 B1	5/2001	Grabek et al.
6,019,724 A	2/2000	Gronningsaeter et al.	6,233,476 B1	5/2001	Strommer et al.
6,019,725 A	2/2000	Vesely et al.	6,233,994 B1	5/2001	Roy et al.
6,022,342 A	2/2000	Mukherjee	6,236,883 B1	5/2001	Ciaccio et al.
6,023,638 A	2/2000	Swanson	6,238,344 B1	5/2001	Gamelsky et al.
6,026,312 A	2/2000	Shemwell et al.	6,241,673 B1	6/2001	Williams et al.
6,031,765 A	2/2000	Lee et al.	6,246,231 B1	6/2001	Ashe
6,032,070 A	2/2000	Flock et al.	6,246,898 B1	6/2001	Vesely et al.
6,039,694 A	3/2000	Larson et al.	6,248,072 B1	6/2001	Murkin et al.
6,050,718 A	4/2000	Schena et al.	6,248,074 B1	6/2001	Ohno et al.
6,052,610 A	4/2000	Koch	6,248,075 B1	6/2001	McGee et al.
6,052,618 A	4/2000	Dahlke et al.	6,253,770 B1	7/2001	Acker et al.
D424,693 S	5/2000	Pruter	6,258,035 B1	7/2001	Hoeksel et al.
6,059,718 A	5/2000	Taniguchi et al.	6,259,941 B1	7/2001	Chia et al.
6,064,905 A	5/2000	Webster, Jr. et al.	6,261,231 B1	7/2001	Damphousse et al.
6,066,094 A	5/2000	Ben-Haim	6,263,230 B1	7/2001	Haynor et al.
6,068,599 A	5/2000	Saito et al.	6,266,550 B1	7/2001	Selmon et al.
6,073,043 A	6/2000	Schneider	6,266,551 B1	7/2001	Osadchy et al.
6,074,367 A	6/2000	Hubbell	6,266,552 B1	7/2001	Slettenmark
6,075,442 A	6/2000	Welch	6,266,563 B1	7/2001	KenKnight et al.
6,076,007 A	6/2000	England et al.	6,270,493 B1	8/2001	Lalonde et al.
6,081,737 A	6/2000	Shah	6,271,833 B1	8/2001	Rosenberg et al.
6,082,366 A	7/2000	Andra et al.	6,272,371 B1	8/2001	Shlomo
6,083,170 A	7/2000	Ben-Haim	6,272,374 B1	8/2001	Flock et al.
6,099,524 A	8/2000	Lipson et al.	6,275,258 B1	8/2001	Chim
6,100,026 A	8/2000	Nova et al.	6,275,724 B1	8/2001	Dickinson et al.
6,102,044 A	8/2000	Naidyhorski	6,277,077 B1	8/2001	Brisken et al.
6,107,699 A	8/2000	Swanson	6,284,459 B1	9/2001	Nova et al.
6,112,111 A	8/2000	Glantz	6,285,898 B1	9/2001	Ben-Haim
6,112,115 A	8/2000	Feldman et al.	6,287,260 B1	9/2001	Hascoet et al.
6,113,504 A	9/2000	Kuesters	6,288,704 B1	9/2001	Flack et al.
6,115,624 A	9/2000	Lewis et al.	6,292,678 B1	9/2001	Hall et al.
6,120,445 A	9/2000	Grunwald	6,292,680 B1	9/2001	Somogyi et al.
6,128,174 A	10/2000	Ritter et al.	6,292,901 B1	9/2001	Lys et al.
6,129,668 A	10/2000	Haynor et al.	6,293,955 B1	9/2001	Houser et al.
6,132,378 A	10/2000	Marino	6,296,604 B1	10/2001	Garibaldi et al.
6,132,379 A	10/2000	Patacsil et al.	6,298,261 B1	10/2001	Rex
6,135,961 A	10/2000	Pflugrath et al.	6,304,768 B1	10/2001	Blume et al.
6,136,274 A	10/2000	Nova et al.	6,306,097 B1	10/2001	Park et al.
6,138,681 A	10/2000	Chen et al.	6,306,105 B1	10/2001	Rooney et al.
6,139,496 A	10/2000	Chen et al.	6,311,082 B1	10/2001	Creighton, IV et al.
6,139,502 A	10/2000	Fredriksen	6,315,709 B1	11/2001	Garibaldi et al.
6,139,540 A	10/2000	Rost et al.	6,315,727 B1	11/2001	Coleman et al.
6,144,300 A	11/2000	Dames et al.	6,319,668 B1	11/2001	Nova et al.
6,148,823 A	11/2000	Hastings	6,323,769 B1	11/2001	Dames et al.
6,152,933 A	11/2000	Werp et al.	6,323,770 B1	11/2001	Dames et al.
6,157,853 A	12/2000	Blume et al.	6,324,416 B1	11/2001	Seibert
6,165,144 A	12/2000	Talish et al.	6,325,540 B1	12/2001	Lounsberry et al.
6,165,977 A	12/2000	Mochly-Rosen	6,325,762 B1	12/2001	Tjin
6,166,496 A	12/2000	Lys et al.	6,329,139 B1	12/2001	Nova et al.
6,166,806 A	12/2000	Tjin	6,329,916 B1	12/2001	Dames et al.
6,167,765 B1	1/2001	Weitzel	6,330,467 B1	12/2001	Creighton, IV et al.
6,172,499 B1	1/2001	Ashe	6,332,089 B1	12/2001	Acker et al.
6,173,199 B1	1/2001	Gabriel	6,332,874 B1	12/2001	Eliassen et al.
6,173,715 B1	1/2001	Sinanan et al.	6,340,588 B1	1/2002	Nova et al.
6,175,756 B1	1/2001	Ferre et al.	6,340,868 B1	1/2002	Lys et al.
6,176,829 B1	1/2001	Vilkomerson	6,341,231 B1	1/2002	Ferre et al.
6,187,744 B1	2/2001	Rooney	6,346,081 B1	2/2002	Vilkomerson
6,190,370 B1	2/2001	Tsui	6,348,911 B1	2/2002	Rosenberg et al.
			6,350,160 B1	2/2002	Feuersanger et al.
			6,352,363 B1	3/2002	Munger et al.
			6,354,999 B1	3/2002	Dgany et al.
			6,355,026 B1	3/2002	Mick

(56)

## References Cited

## U.S. PATENT DOCUMENTS

6,356,791 B1 *	3/2002	Westlund .....	A61M 25/09 607/115	6,522,907 B1	2/2003	Bladen et al.
6,360,123 B1	3/2002	Kimchi et al.		6,522,909 B1	2/2003	Garibaldi et al.
6,361,499 B1	3/2002	Bates et al.		6,524,303 B1	2/2003	Garibaldi
6,364,823 B1	4/2002	Garibaldi et al.		6,528,954 B1	3/2003	Lys et al.
6,364,839 B1	4/2002	Little et al.		6,528,991 B2	3/2003	Ashe
6,366,804 B1	4/2002	Mejia		6,529,761 B2	3/2003	Creighton, IV et al.
6,368,285 B1	4/2002	Osadchy et al.		6,529,766 B1	3/2003	Guendel
6,370,411 B1	4/2002	Osadchy et al.		6,534,982 B1	3/2003	Jakab
6,373,240 B1	4/2002	Govari		6,535,625 B1	3/2003	Chang et al.
6,373,388 B1	4/2002	Dames et al.		6,537,192 B1	3/2003	Elliott et al.
6,374,134 B1	4/2002	Bladen et al.		6,537,196 B1	3/2003	Creighton, IV et al.
6,374,670 B1	4/2002	Spelman et al.		6,538,634 B1	3/2003	Chui et al.
6,375,606 B1	4/2002	Garibaldi et al.		6,540,699 B1	4/2003	Smith et al.
6,375,639 B1	4/2002	Duplessie et al.		6,542,766 B2	4/2003	Hall et al.
6,377,857 B1	4/2002	Brayton et al.		6,544,251 B1	4/2003	Crawford
6,379,302 B1	4/2002	Kessman et al.		6,545,678 B1	4/2003	Ohazama
6,379,303 B1	4/2002	Seitz et al.		6,546,270 B1	4/2003	Goldin et al.
6,379,307 B1	4/2002	Filly et al.		6,546,279 B1	4/2003	Bova et al.
6,381,485 B1	4/2002	Hunter et al.		6,546,787 B1	4/2003	Schiller et al.
6,385,472 B1	5/2002	Hall et al.		6,552,841 B1	4/2003	Lasser et al.
6,385,476 B1	5/2002	Osadchy et al.		6,556,858 B1	4/2003	Zeman
6,398,736 B1	6/2002	Seward		6,562,019 B1	5/2003	Sell
6,398,738 B1	6/2002	Millar		6,564,087 B1	5/2003	Pitris et al.
6,401,723 B1	6/2002	Garibaldi et al.		6,569,101 B2	5/2003	Quistgaard et al.
6,406,422 B1	6/2002	Landesberg		6,569,103 B2	5/2003	Hoeksel et al.
6,406,442 B1	6/2002	McFann et al.		6,569,160 B1	5/2003	Goldin et al.
6,412,978 B1	7/2002	Watanabe et al.		6,569,862 B1	5/2003	Marban
6,412,980 B1	7/2002	Lounsberry et al.		6,571,004 B1	5/2003	Florent et al.
6,417,839 B1	7/2002	Odell		6,574,518 B1	6/2003	Luonsberry et al.
6,418,332 B1	7/2002	Mastrototaro et al.		6,575,908 B2	6/2003	Barnes et al.
6,418,335 B2	7/2002	Avrin et al.		6,577,080 B2	6/2003	Lys et al.
6,423,002 B1	7/2002	Hossack		6,577,896 B2	6/2003	Werner et al.
6,423,050 B1	7/2002	Twardowski		6,584,343 B1	6/2003	Ransbury et al.
6,427,079 B1	7/2002	Schneider et al.		6,593,754 B1	7/2003	Steber et al.
6,428,551 B1	8/2002	Hall et al.		6,593,884 B1	7/2003	Gilboa et al.
6,430,315 B1	8/2002	Makram-Ebeid		6,597,943 B2	7/2003	Taha et al.
6,432,069 B1	8/2002	Godo et al.		6,599,249 B1	7/2003	Nordgren et al.
6,438,411 B1	8/2002	Guttman et al.		6,607,488 B1	8/2003	Jackson et al.
6,442,416 B1	8/2002	Schultz		6,610,058 B2	8/2003	Flores
6,445,943 B1	9/2002	Ferre et al.		6,611,141 B1	8/2003	Schulz et al.
6,456,874 B1	9/2002	Hafer et al.		6,615,071 B1	9/2003	Casscells, III et al.
6,459,919 B1	10/2002	Lys et al.		6,615,155 B2	9/2003	Gilboa
6,463,121 B1	10/2002	Milnes		6,616,610 B2	9/2003	Steininger et al.
6,466,815 B1	10/2002	Saito et al.		6,618,612 B1	9/2003	Acker et al.
6,471,656 B1	10/2002	Shalman et al.		6,626,832 B1	9/2003	Paltieli et al.
6,471,658 B1	10/2002	Daniels et al.		6,626,834 B2	9/2003	Dunne et al.
6,471,700 B1	10/2002	Burbank et al.		6,626,902 B1	9/2003	Kucharczyk et al.
6,473,167 B1	10/2002	Odell		6,630,879 B1	10/2003	Creighton, IV et al.
6,474,341 B1	11/2002	Hunter et al.		6,635,027 B1	10/2003	Cragg et al.
6,475,152 B1	11/2002	Kelly, Jr. et al.		6,645,148 B2	11/2003	Nguyen-Dinh et al.
6,475,223 B1	11/2002	Werp et al.		6,648,875 B2	11/2003	Simpson et al.
6,477,402 B1	11/2002	Lynch et al.		6,649,914 B1	11/2003	Moorman et al.
6,484,118 B1	11/2002	Govari et al.		6,652,505 B1	11/2003	Tsugita
6,487,916 B1	12/2002	Gomm et al.		6,652,506 B2	11/2003	Bowe et al.
6,491,671 B1	12/2002	Larson, III et al.		6,660,024 B1	12/2003	Flaherty et al.
6,493,573 B1	12/2002	Martinelli et al.		6,662,034 B2	12/2003	Segner et al.
6,494,832 B1	12/2002	Feldman et al.		6,663,661 B2	12/2003	Boneau
6,496,715 B1	12/2002	Lee et al.		6,666,828 B2	12/2003	Greco et al.
6,498,944 B1	12/2002	Ben-Haim et al.		6,672,308 B1	1/2004	Gaspari et al.
6,500,141 B1	12/2002	Irion et al.		6,677,752 B1	1/2004	Creighton, IV et al.
6,505,062 B1	1/2003	Ritter et al.		6,679,857 B1	1/2004	Bastia et al.
6,506,159 B2	1/2003	Hascoet et al.		6,684,176 B2	1/2004	Willins et al.
6,507,751 B2	1/2003	Blume et al.		6,685,644 B2	2/2004	Seo et al.
6,508,802 B1	1/2003	Rosengart et al.		6,687,531 B1	2/2004	Ferre et al.
6,511,413 B2	1/2003	Landesberg		6,689,119 B1	2/2004	Di Caprio et al.
6,512,958 B1	1/2003	Swoyer et al.		6,690,963 B2	2/2004	Ben-Haim et al.
6,514,226 B1	2/2003	Levin et al.		6,690,964 B2	2/2004	Bieger et al.
6,514,249 B1	2/2003	Maguire et al.		6,690,968 B2	2/2004	Mejia
6,515,657 B1	2/2003	Zanelli		6,694,167 B1	2/2004	Ferre et al.
6,516,212 B1	2/2003	Bladen et al.		6,695,786 B2	2/2004	Wang et al.
6,516,231 B1	2/2003	Flammang		6,701,179 B1	3/2004	Martinelli et al.
6,516,807 B1	2/2003	Panescu et al.		6,701,918 B2	3/2004	Fariss et al.
6,517,520 B2	2/2003	Chang et al.		6,702,804 B1	3/2004	Ritter et al.
6,522,906 B1	2/2003	Salisbury, Jr. et al.		6,704,590 B2	3/2004	Haldeman
				6,709,390 B1	3/2004	Marie Pop
				6,711,429 B1	3/2004	Gilboa et al.
				6,711,431 B2	3/2004	Sarin et al.
				6,719,699 B2	4/2004	Smith
				6,719,724 B1	4/2004	Walker et al.

(56)

## References Cited

## U.S. PATENT DOCUMENTS

6,719,756	B1	4/2004	Muntermann	7,020,512	B2	3/2006	Ritter et al.
6,720,745	B2	4/2004	Lys et al.	D518,574	S	4/2006	Chaggares
6,733,458	B1	5/2004	Steins et al.	7,022,075	B2	4/2006	Grunwald et al.
6,733,511	B2	5/2004	Hall et al.	7,022,082	B2	4/2006	Sonek
6,736,782	B2	5/2004	Pfeiffer et al.	7,026,927	B2	4/2006	Wright et al.
6,738,656	B1	5/2004	Ferre et al.	7,027,634	B2	4/2006	Odell
6,740,103	B2	5/2004	Hall et al.	7,028,387	B1	4/2006	Huynh et al.
6,743,177	B2	6/2004	Ito et al.	7,029,446	B2	4/2006	Wendelken et al.
6,754,596	B2	6/2004	Ashe	7,033,603	B2	4/2006	Nelson et al.
6,755,789	B2	6/2004	Stringer et al.	D520,139	S	5/2006	Chaggares
6,755,816	B2	6/2004	Ritter et al.	D520,140	S	5/2006	Chaggares
6,755,822	B2	6/2004	Reu et al.	7,038,398	B1	5/2006	Lys et al.
6,757,557	B1	6/2004	Bladen et al.	7,038,657	B2	5/2006	Rosenberg et al.
6,763,261	B2	7/2004	Casscells, III et al.	7,043,293	B1	5/2006	Baura
6,764,449	B2	7/2004	Lee et al.	7,048,733	B2	5/2006	Hartley et al.
6,768,496	B2	7/2004	Bieger et al.	7,054,228	B1	5/2006	Hickling
6,772,001	B2	8/2004	Maschke et al.	7,065,403	B1	6/2006	Mouchawar et al.
6,774,624	B2	8/2004	Anderson et al.	7,066,914	B2	6/2006	Andersen
6,783,536	B2	8/2004	Vilsmeier et al.	7,066,924	B1	6/2006	Garibaldi et al.
6,784,660	B2	8/2004	Ashe	7,069,072	B2	6/2006	Jansen et al.
6,785,571	B2	8/2004	Glossop et al.	D525,363	S	7/2006	Chaggares
6,786,219	B2	9/2004	Garibaldi et al.	7,070,565	B2	7/2006	Vaezy et al.
6,786,870	B2	9/2004	Miyaki et al.	7,072,704	B2	7/2006	Buchholz
6,788,967	B2	9/2004	Ben-Haim et al.	7,082,325	B2	7/2006	Hashimshony et al.
6,794,667	B2	9/2004	Noshi	7,090,639	B2	8/2006	Govari
6,799,066	B2	9/2004	Steines et al.	7,096,059	B2	8/2006	Geddes et al.
6,815,651	B2	11/2004	Odell	7,096,148	B2	8/2006	Anderson et al.
6,816,266	B2	11/2004	Varshneya et al.	7,096,870	B2	8/2006	Lamprich et al.
6,817,364	B2	11/2004	Garibaldi et al.	7,098,907	B2	8/2006	Houston et al.
6,834,201	B2	12/2004	Gillies et al.	7,103,205	B2	9/2006	Wang et al.
6,844,713	B2	1/2005	Steber et al.	7,104,980	B1	9/2006	Laherty et al.
6,845,142	B2	1/2005	Ohishi	7,106,043	B1	9/2006	Da Silva et al.
6,856,823	B2	2/2005	Ashe	7,106,431	B2	9/2006	Odell
6,860,422	B2	3/2005	Hull et al.	7,106,479	B2	9/2006	Roy et al.
6,862,467	B2	3/2005	Moore et al.	7,107,105	B2	9/2006	Bjorklund et al.
6,869,390	B2	3/2005	Elliott et al.	7,112,197	B2	9/2006	Hartley et al.
6,875,179	B2	4/2005	Ferguson et al.	7,128,734	B1	10/2006	Wilson et al.
6,879,160	B2	4/2005	Jakab	7,132,804	B2	11/2006	Lys et al.
6,887,206	B2	5/2005	Hoeksel et al.	7,137,976	B2	11/2006	Ritter et al.
6,889,091	B2	5/2005	Hine et al.	7,141,019	B2	11/2006	Pearlman
6,895,268	B1	5/2005	Rahn et al.	7,141,812	B2	11/2006	Appleby et al.
6,902,528	B1	6/2005	Garibaldi et al.	7,142,905	B2	11/2006	Slayton et al.
6,905,469	B2	6/2005	Hascoet et al.	7,148,970	B2	12/2006	de Boer
6,908,433	B1	6/2005	Pruter	7,153,291	B2	12/2006	Bierman
6,911,026	B1	6/2005	Hall et al.	7,161,453	B2	1/2007	Creighton, IV
6,923,782	B2	8/2005	O'Mahony et al.	7,162,291	B1	1/2007	Nachaliel
6,926,673	B2	8/2005	Roberts et al.	7,167,738	B2	1/2007	Schweikard et al.
6,926,674	B2	8/2005	Tenerz et al.	7,169,107	B2	1/2007	Jersey-Willuhn et al.
6,934,575	B2	8/2005	Ferre et al.	7,169,109	B2	1/2007	Jansen et al.
6,936,010	B2	8/2005	Fang et al.	7,174,201	B2	2/2007	Govari et al.
6,939,313	B2	9/2005	Saadat et al.	7,175,646	B2	2/2007	Brenneman et al.
6,940,379	B2	9/2005	Creighton	7,180,252	B2	2/2007	Lys et al.
6,941,166	B2	9/2005	MacAdam et al.	7,184,820	B2	2/2007	Jersey-Willuhn et al.
6,947,788	B2	9/2005	Gilboa et al.	7,189,198	B2	3/2007	Harburn et al.
6,950,689	B1	9/2005	Willis et al.	7,189,205	B2	3/2007	McMorrow et al.
6,953,754	B2	10/2005	Machida et al.	7,189,208	B1	3/2007	Beatty et al.
6,958,677	B1	10/2005	Carter	7,190,819	B2	3/2007	Viswanathan
6,959,214	B2	10/2005	Pape et al.	7,194,295	B2	3/2007	Vilsmeier
6,962,566	B2	11/2005	Quistgaard et al.	7,204,798	B2	4/2007	Zdeblick et al.
6,968,846	B2	11/2005	Viswanathan	7,206,064	B2	4/2007	Rogers et al.
6,975,197	B2	12/2005	Creighton, IV	7,207,941	B2	4/2007	Sharf
6,976,962	B2	12/2005	Bullis	7,211,082	B2	5/2007	Hall et al.
6,976,987	B2	12/2005	Flores	7,214,191	B2	5/2007	Stringer et al.
6,980,843	B2	12/2005	Eng et al.	7,215,326	B2	5/2007	Rosenberg
6,980,852	B2	12/2005	Jersey-Willuhn et al.	7,221,104	B2	5/2007	Lys et al.
6,980,921	B2	12/2005	Anderson et al.	7,223,256	B2	5/2007	Bierman
6,986,739	B2	1/2006	Warren et al.	7,229,400	B2	6/2007	Elliott et al.
6,986,744	B1	1/2006	Krivitski	7,231,243	B2	6/2007	Tearney et al.
6,999,821	B2	2/2006	Jenney et al.	7,236,157	B2	6/2007	Schena et al.
7,001,355	B2	2/2006	Nunomura et al.	7,236,816	B2	6/2007	Kumar et al.
7,008,418	B2	3/2006	Hall et al.	7,236,820	B2	6/2007	Mabary et al.
7,010,338	B2	3/2006	Ritter et al.	7,237,313	B2	7/2007	Skujins et al.
7,015,393	B2	3/2006	Weiner et al.	7,241,267	B2	7/2007	Furia
7,017,584	B2	3/2006	Garibaldi et al.	7,244,234	B2	7/2007	Ridley et al.
7,019,610	B2	3/2006	Creighton, IV et al.	7,248,032	B1	7/2007	Hular et al.
				7,248,914	B2	7/2007	Hastings et al.
				7,252,633	B2	8/2007	Obata et al.
				7,264,584	B2	9/2007	Ritter et al.
				7,270,662	B2	9/2007	Visram et al.

(56)

## References Cited

## U.S. PATENT DOCUMENTS

7,276,044	B2	10/2007	Ferry et al.	7,869,854	B2	1/2011	Shachar et al.
7,286,034	B2	10/2007	Creighton	7,873,402	B2	1/2011	Shachar
7,291,146	B2	11/2007	Steinke et al.	7,909,815	B2	3/2011	Whitmore et al.
7,297,140	B2	11/2007	Orlu et al.	7,931,596	B2	4/2011	Rachlin et al.
7,300,430	B2	11/2007	Wilson et al.	7,947,040	B2	5/2011	Davies et al.
7,302,288	B1	11/2007	Schellenberg	7,976,469	B2	7/2011	Bonde et al.
7,308,296	B2	12/2007	Lys et al.	7,976,518	B2	7/2011	Shaughnessy et al.
7,310,150	B2	12/2007	Guillermo et al.	7,981,038	B2	7/2011	Kanade et al.
7,311,702	B2	12/2007	Tallarida et al.	7,988,633	B2	8/2011	Hossack et al.
7,321,228	B2	1/2008	Govari	8,016,814	B2	9/2011	Blakstvedt et al.
7,326,241	B2	2/2008	Jang	8,046,052	B2	10/2011	Verard et al.
7,327,872	B2	2/2008	Vaillant et al.	8,057,394	B2	11/2011	Dala-Krishna
7,342,058	B2	3/2008	Peppmoller et al.	8,060,185	B2	11/2011	Hunter et al.
7,349,732	B1	3/2008	Kil et al.	8,078,274	B2	12/2011	Kassab
7,355,716	B2	4/2008	de Boer et al.	8,078,279	B2	12/2011	Dennis et al.
7,360,427	B2	4/2008	Drinkwater et al.	8,082,032	B2	12/2011	Kassab et al.
7,366,376	B2	4/2008	Shishkov et al.	8,088,072	B2	1/2012	Munrow et al.
7,366,562	B2	4/2008	Dukesherer et al.	8,090,430	B2	1/2012	Makower et al.
7,366,563	B2	4/2008	Kleen et al.	8,099,161	B2	1/2012	Kassab
7,373,271	B1	5/2008	Schneider	8,114,143	B2	2/2012	Kassab et al.
7,381,204	B2	6/2008	Wilson et al.	8,118,743	B2	2/2012	Park et al.
7,382,949	B2	6/2008	Bouma et al.	8,123,691	B2	2/2012	Mine et al.
7,384,407	B2	6/2008	Rodriguez et al.	8,133,698	B2	3/2012	Silver
7,418,169	B2	8/2008	Tearney et al.	8,142,417	B2	3/2012	Pajunk et al.
7,447,408	B2	11/2008	Bouma et al.	8,150,522	B2	4/2012	Echaz et al.
7,452,331	B1	11/2008	Pruter	8,152,724	B2	4/2012	Ridley et al.
7,452,358	B2	11/2008	Stern et al.	8,204,582	B2	6/2012	Zantos et al.
7,454,244	B2	11/2008	Kassab et al.	8,214,018	B2	7/2012	Markowitz et al.
D585,556	S	1/2009	Kosaku	8,221,402	B2	7/2012	Francischelli et al.
7,479,141	B2	1/2009	Kleen et al.	8,240,211	B2	8/2012	Zeitner et al.
7,519,424	B2	4/2009	Dennis et al.	8,241,274	B2	8/2012	Keogh et al.
7,529,584	B2	5/2009	Laske et al.	8,244,339	B2	8/2012	Shen et al.
7,534,223	B2	5/2009	Boutillette et al.	8,255,035	B2	8/2012	Cao et al.
7,538,859	B2	5/2009	Tearney et al.	8,260,395	B2	9/2012	Markowitz et al.
7,543,239	B2	6/2009	Viswanathan et al.	8,262,577	B2	9/2012	Munrow et al.
7,546,158	B2	6/2009	Allison et al.	8,298,149	B2	10/2012	Hastings et al.
7,547,282	B2	6/2009	Lo et al.	8,303,502	B2	11/2012	Washburn et al.
7,551,293	B2	6/2009	Yelin et al.	8,303,505	B2	11/2012	Webler et al.
D603,050	S	10/2009	Chen	8,326,419	B2	12/2012	Rosenberg et al.
7,599,730	B2	10/2009	Hunter et al.	8,340,751	B2	12/2012	Markowitz et al.
7,606,615	B2	10/2009	Makower et al.	8,369,922	B2	2/2013	Paul et al.
7,616,992	B2	11/2009	Dennis et al.	8,388,541	B2	3/2013	Messeryly et al.
7,627,376	B2	12/2009	Dennis et al.	8,388,546	B2	3/2013	Rothenberg
7,635,336	B1	12/2009	Pruter	8,391,956	B2	3/2013	Zellers et al.
7,637,163	B2	12/2009	Fetzer et al.	8,401,616	B2	3/2013	Verard et al.
7,640,053	B2	12/2009	Verin	8,409,103	B2	4/2013	Grunwald et al.
7,651,469	B2	1/2010	Osborne et al.	8,425,425	B2	4/2013	Nagy et al.
7,652,080	B2	1/2010	Peppmoller et al.	8,437,833	B2	5/2013	Silverstein
7,660,623	B2	2/2010	Hunter et al.	8,439,873	B1	5/2013	Donovan
7,665,893	B2	2/2010	Buchalter	8,442,621	B2	5/2013	Gorek et al.
7,668,583	B2	2/2010	Fegert et al.	8,447,384	B2	5/2013	Xu et al.
7,697,972	B2	4/2010	Verard et al.	D684,265	S	6/2013	Cadera
7,699,782	B2	4/2010	Angelsen et al.	8,456,182	B2	6/2013	Bar-Tal et al.
7,699,829	B2	4/2010	Harris et al.	8,478,382	B2	7/2013	Burnside et al.
7,715,925	B2	5/2010	Hafer et al.	8,485,980	B2	7/2013	Sinderby et al.
7,727,192	B2	6/2010	Tokumoto et al.	8,494,608	B2	7/2013	Markowitz et al.
7,729,743	B2	6/2010	Sabczynski et al.	8,496,592	B2	7/2013	Ridley et al.
7,751,865	B2	7/2010	Jascob et al.	8,504,139	B2	8/2013	Jacobsen et al.
7,766,839	B2	8/2010	Rogers et al.	8,512,256	B2	8/2013	Rothenberg
7,771,437	B2	8/2010	Hogg et al.	8,527,036	B2	9/2013	Jalde et al.
7,774,051	B2	8/2010	Voth	8,538,509	B2	9/2013	Harley et al.
7,774,055	B1	8/2010	Min	8,644,907	B2	2/2014	Hartmann et al.
7,794,407	B2	9/2010	Rothenberg	8,690,776	B2	4/2014	Razzaque et al.
7,798,970	B2	9/2010	Lo et al.	8,734,440	B2	5/2014	Wu
7,819,810	B2	10/2010	Stringer et al.	8,774,907	B2	7/2014	Rothenberg
7,828,528	B2	11/2010	Estes et al.	8,781,555	B2	7/2014	Burnside et al.
7,831,294	B2	11/2010	Viswanathan	8,784,336	B2	7/2014	Bown et al.
7,833,168	B2	11/2010	Taylor et al.	8,801,693	B2	8/2014	He et al.
7,833,214	B2	11/2010	Wilson et al.	8,849,382	B2	9/2014	Cox et al.
D629,526	S	12/2010	Ladwig et al.	8,858,455	B2	10/2014	Rothenberg
D629,527	S	12/2010	Crunkilton	8,934,961	B2	1/2015	Lakin et al.
7,846,157	B2	12/2010	Kozel	8,971,994	B2	3/2015	Burnside et al.
7,850,613	B2	12/2010	Stribling	9,125,578	B2	9/2015	Grunwald
D630,756	S	1/2011	Kitayama	9,339,206	B2	5/2016	Grunwald
D630,757	S	1/2011	Kitayama	9,456,766	B2	10/2016	Cox et al.
				9,492,097	B2	11/2016	Wilkes et al.
				9,521,961	B2	12/2016	Silverstein et al.
				9,526,440	B2	12/2016	Burnside et al.
				9,532,724	B2	1/2017	Grunwald

(56)

## References Cited

## U.S. PATENT DOCUMENTS

9,554,716 B2	1/2017	Burnside et al.	2004/0116809 A1	6/2004	Chow et al.
9,636,031 B2	5/2017	Cox	2004/0127805 A1	7/2004	MacAdam et al.
9,642,986 B2	5/2017	Beasley	2004/0131998 A1	7/2004	Marom et al.
2002/0010392 A1	1/2002	Desai	2004/0133111 A1	7/2004	Szcezech et al.
2002/0019447 A1	2/2002	Renn et al.	2004/0133130 A1	7/2004	Ferry et al.
2002/0022777 A1	2/2002	Crieghton et al.	2004/0135069 A1	7/2004	Odell
2002/0032391 A1	3/2002	McFann et al.	2004/0138557 A1	7/2004	Le et al.
2002/0049488 A1	4/2002	Boneau	2004/0138564 A1	7/2004	Hwang et al.
2002/0055680 A1	5/2002	Miele et al.	2004/0138570 A1	7/2004	Nita et al.
2002/0082559 A1	6/2002	Chang et al.	2004/0147837 A1	7/2004	Macaulay et al.
2002/0113555 A1	8/2002	Lys et al.	2004/0150963 A1	8/2004	Holmberg et al.
2002/0123679 A1	9/2002	Dominguez	2004/0152972 A1	8/2004	Hunter
2002/0128554 A1	9/2002	Seward	2004/0155609 A1	8/2004	Lys et al.
2002/0129952 A1	9/2002	Matsudate et al.	2004/0158140 A1	8/2004	Fuimaono et al.
2002/0133079 A1	9/2002	Sandhu	2004/0171924 A1	9/2004	Mire et al.
2002/0156363 A1	10/2002	Hunter et al.	2004/0176688 A1	9/2004	Haldeman
2002/0156376 A1	10/2002	Wang et al.	2004/0186461 A1	9/2004	DiMatteo
2002/0165448 A1	11/2002	Ben-Haim et al.	2004/0199069 A1	10/2004	Connelly et al.
2002/0165534 A1	11/2002	Hayzelden et al.	2004/0210289 A1	10/2004	Wang et al.
2002/0165537 A1	11/2002	Kelley et al.	2004/0225233 A1	11/2004	Frankowski et al.
2002/0198568 A1	12/2002	Hafer et al.	2004/0230131 A1	11/2004	Kassab et al.
2003/0009132 A1	1/2003	Schwartz et al.	2004/0230271 A1	11/2004	Wang et al.
2003/0011359 A1	1/2003	Ashe	2004/0234453 A1	11/2004	Smith
2003/0013966 A1	1/2003	Barnes et al.	2004/0243018 A1	12/2004	Organ et al.
2003/0013986 A1	1/2003	Saadat	2004/0243116 A1	12/2004	Joye et al.
2003/0018251 A1	1/2003	Solomon	2004/0243118 A1	12/2004	Ayers et al.
2003/0036696 A1	2/2003	Willis et al.	2004/0253365 A1	12/2004	Warren et al.
2003/0040671 A1	2/2003	Somogyi et al.	2004/0254470 A1	12/2004	Drinkwater et al.
2003/0040743 A1	2/2003	Cosman et al.	2004/0254495 A1	12/2004	Mabary et al.
2003/0072805 A1	4/2003	Miyazawa et al.	2004/0260174 A1	12/2004	Keene
2003/0073901 A1	4/2003	Simon et al.	2004/0267086 A1	12/2004	Anstadt et al.
2003/0076281 A1	4/2003	Morgan et al.	2005/0004450 A1	1/2005	Ben-Haim et al.
2003/0083698 A1	5/2003	Whitehurst et al.	2005/0021019 A1	1/2005	Hashimshony et al.
2003/0088195 A1	5/2003	Vardi et al.	2005/0033150 A1	2/2005	Takahashi et al.
2003/0100849 A1	5/2003	Jang	2005/0038355 A1	2/2005	Gellman et al.
2003/0114742 A1	6/2003	Lewkowicz et al.	2005/0043640 A1	2/2005	Chang
2003/0114777 A1	6/2003	Griffin et al.	2005/0049486 A1	3/2005	Urquhart et al.
2003/0120150 A1	6/2003	Govari	2005/0049510 A1	3/2005	Haldeman et al.
2003/0120154 A1	6/2003	Sauer et al.	2005/0063194 A1	3/2005	Lys et al.
2003/0139661 A1	7/2003	Kimchy et al.	2005/0070788 A1	3/2005	Wilson et al.
2003/0149328 A1	8/2003	Elliott et al.	2005/0075561 A1	4/2005	Golden
2003/0149368 A1	8/2003	Hennemann et al.	2005/0085716 A1	4/2005	Hamm et al.
2003/0152290 A1	8/2003	Odell	2005/0085718 A1	4/2005	Shahidi
2003/0160721 A1	8/2003	Gilboa et al.	2005/0085720 A1	4/2005	Jascob et al.
2003/0163037 A1	8/2003	Bladen et al.	2005/0090746 A1	4/2005	Ohtake
2003/0163142 A1	8/2003	Paltieli et al.	2005/0101868 A1	5/2005	Ridley et al.
2003/0171691 A1	9/2003	Casscells et al.	2005/0101869 A1	5/2005	Burba et al.
2003/0173953 A1	9/2003	Ashe	2005/0105081 A1	5/2005	Odell
2003/0181892 A1	9/2003	Pajunk et al.	2005/0105101 A1	5/2005	Duling et al.
2003/0184544 A1	10/2003	Prudent	2005/0112135 A1	5/2005	Cormier et al.
2003/0191392 A1	10/2003	Haldeman	2005/0113669 A1	5/2005	Helfer et al.
2003/0191460 A1	10/2003	Hobbs et al.	2005/0113676 A1	5/2005	Weiner et al.
2003/0195420 A1	10/2003	Mendlein et al.	2005/0113700 A1	5/2005	Yanagihara et al.
2003/0199746 A1	10/2003	Fuimaono et al.	2005/0113873 A1	5/2005	Weiner et al.
2003/0208142 A1	11/2003	Boudewijn et al.	2005/0113874 A1	5/2005	Connelly et al.
2003/0216639 A1	11/2003	Gilboa et al.	2005/0113876 A1	5/2005	Weiner et al.
2003/0220557 A1	11/2003	Cleary et al.	2005/0148836 A1	7/2005	Kleen et al.
2003/0220578 A1	11/2003	Ho et al.	2005/0148902 A1	7/2005	Minar et al.
2003/0229298 A1	12/2003	Iwami et al.	2005/0149002 A1	7/2005	Wang et al.
2003/0233042 A1	12/2003	Ashe	2005/0151489 A1	7/2005	Lys et al.
2003/0236445 A1	12/2003	Couvillon	2005/0154308 A1	7/2005	Quistgaard et al.
2004/0010189 A1	1/2004	van Sloun et al.	2005/0159644 A1	7/2005	Takano
2004/0015070 A1	1/2004	Liang et al.	2005/0159790 A1	7/2005	Shalev
2004/0024301 A1	2/2004	Hockett et al.	2005/0165301 A1	7/2005	Smith et al.
2004/0030319 A1	2/2004	Korkor et al.	2005/0165313 A1	7/2005	Byron et al.
2004/0054278 A1	3/2004	Kimchy et al.	2005/0175665 A1	8/2005	Hunter et al.
2004/0059237 A1	3/2004	Narayan et al.	2005/0175703 A1	8/2005	Hunter et al.
2004/0082916 A1	4/2004	Jenkins	2005/0178395 A1	8/2005	Hunter et al.
2004/0087877 A1	5/2004	Besz et al.	2005/0178396 A1	8/2005	Hunter et al.
2004/0088136 A1	5/2004	Ashe	2005/0182295 A1	8/2005	Soper et al.
2004/0092962 A1	5/2004	Thornton et al.	2005/0182454 A1	8/2005	Gharib et al.
2004/0097803 A1	5/2004	Panescu	2005/0197674 A1	9/2005	McCabe et al.
2004/0097804 A1	5/2004	Sobe	2005/0203368 A1	9/2005	Verin
2004/0097805 A1	5/2004	Verard et al.	2005/0203396 A1	9/2005	Angelsen et al.
2004/0097806 A1	5/2004	Hunter et al.	2005/0205081 A1	9/2005	Barker et al.
			2005/0215901 A1	9/2005	Anderson et al.
			2005/0215945 A1	9/2005	Harris et al.
			2005/0222532 A1	10/2005	Bertolero et al.
			2005/0240102 A1	10/2005	Rachlin et al.

(56)

References Cited

U.S. PATENT DOCUMENTS

2005/0245811 A1	11/2005	Scheffler	2007/0225589 A1	9/2007	Viswanathan
2005/0256398 A1	11/2005	Hastings et al.	2007/0225610 A1	9/2007	Mickley et al.
2005/0256451 A1	11/2005	Adams et al.	2007/0232882 A1	10/2007	Glossop et al.
2005/0256521 A1	11/2005	Kozel	2007/0232896 A1	10/2007	Gilboa et al.
2005/0256541 A1	11/2005	Stypulkowski	2007/0238984 A1	10/2007	Maschke et al.
2005/0283210 A1	12/2005	Blischak et al.	2007/0239018 A1	10/2007	Fetzer et al.
2005/0283216 A1	12/2005	Pyles	2007/0244413 A1	10/2007	Biggins
2005/0288586 A1	12/2005	Ferek-Petric	2007/0247454 A1	10/2007	Rahn et al.
2006/0009759 A1	1/2006	Christian et al.	2007/0249911 A1	10/2007	Simon
2006/0015003 A1	1/2006	Moaddes et al.	2007/0255270 A1	11/2007	Carney
2006/0025677 A1	2/2006	Verard et al.	2007/0265526 A1	11/2007	Govari et al.
2006/0025697 A1	2/2006	Kurzweil et al.	2007/0280974 A1	12/2007	Son et al.
2006/0058633 A1	3/2006	Hoshino et al.	2007/0282196 A1	12/2007	Birk et al.
2006/0068074 A1	3/2006	Stefandl	2007/0282197 A1	12/2007	Bill et al.
2006/0084867 A1	4/2006	Tremblay et al.	2007/0299352 A1	12/2007	Harley et al.
2006/0106306 A1	5/2006	Essner et al.	2007/0299353 A1	12/2007	Harlev et al.
2006/0116571 A1	6/2006	Maschke et al.	2008/0004652 A1	1/2008	Abboud et al.
2006/0116576 A1	6/2006	McGee et al.	2008/0008745 A1	1/2008	Stinchcomb et al.
2006/0116578 A1	6/2006	Grunwald et al.	2008/0009720 A1	1/2008	Schefelker et al.
2006/0122514 A1	6/2006	Byrd et al.	2008/0015442 A1	1/2008	Watson et al.
2006/0142656 A1	6/2006	Malackowski et al.	2008/0027320 A1	1/2008	Bolorforosh et al.
2006/0149134 A1	7/2006	Soper et al.	2008/0033283 A1	2/2008	Dellaca et al.
2006/0173251 A1	8/2006	Govari et al.	2008/0033316 A1	2/2008	Kassab et al.
2006/0173329 A1	8/2006	Irioka et al.	2008/0033350 A1	2/2008	Wilson et al.
2006/0173407 A1	8/2006	Shaughnessy et al.	2008/0045908 A1	2/2008	Gould et al.
2006/0176242 A1	8/2006	Jaramaz et al.	2008/0051626 A1	2/2008	Sato et al.
2006/0184074 A1	8/2006	Vaezy et al.	2008/0077158 A1	3/2008	Haider et al.
2006/0206037 A1	9/2006	Braxton	2008/0081958 A1	4/2008	Denison et al.
2006/0211944 A1	9/2006	Mauge et al.	2008/0082136 A1	4/2008	Gaudiani
2006/0217655 A1	9/2006	Vitullo et al.	2008/0097232 A1	4/2008	Rothenberg
2006/0224188 A1	10/2006	Libbus et al.	2008/0108949 A1	5/2008	Beasley et al.
2006/0247746 A1	11/2006	Danek et al.	2008/0114095 A1	5/2008	Peppmoller et al.
2006/0258895 A1	11/2006	Maschke	2008/0125772 A1	5/2008	Stone et al.
2006/0276867 A1	12/2006	Viswanathan	2008/0139944 A1	6/2008	Weymer et al.
2006/0287595 A1	12/2006	Maschke	2008/0146939 A1	6/2008	McMorrow et al.
2007/0010753 A1	1/2007	MacAdam	2008/0146940 A1	6/2008	Jenkins et al.
2007/0016007 A1	1/2007	Govari et al.	2008/0146942 A1	6/2008	Dala-Krishna
2007/0016013 A1	1/2007	Camus	2008/0154100 A1	6/2008	Thalmeier et al.
2007/0016068 A1	1/2007	Grunwald et al.	2008/0166453 A1	7/2008	Steele et al.
2007/0016069 A1	1/2007	Grunwald et al.	2008/0171934 A1	7/2008	Greenan et al.
2007/0016070 A1	1/2007	Grunwald et al.	2008/0183075 A1	7/2008	Govari et al.
2007/0016072 A1	1/2007	Grunwald et al.	2008/0188830 A1	8/2008	Rosenblatt et al.
2007/0032746 A1	2/2007	Sell	2008/0190438 A1	8/2008	Harlev et al.
2007/0038113 A1	2/2007	Oonuki et al.	2008/0195169 A1	8/2008	Pinter et al.
2007/0049822 A1	3/2007	Bunce et al.	2008/0200754 A1	8/2008	Buchalter
2007/0049846 A1*	3/2007	Bown et al. .... 600/585	2008/0228082 A1	9/2008	Scheirer et al.
2007/0055141 A1	3/2007	Kruger et al.	2008/0236598 A1	10/2008	Gobel
2007/0055142 A1	3/2007	Webler	2008/0255404 A1	10/2008	Nogawa et al.
2007/0055294 A1	3/2007	Giap	2008/0255475 A1	10/2008	Kondrosky et al.
2007/0060992 A1	3/2007	Pappone	2008/0269581 A1	10/2008	Wood et al.
2007/0062544 A1	3/2007	Rauk Bergstrom et al.	2008/0269611 A1	10/2008	Pedrizzetti et al.
2007/0066888 A1	3/2007	Maschke	2008/0275465 A1	11/2008	Paul et al.
2007/0073155 A1	3/2007	Park et al.	2008/0275765 A1	11/2008	Kuchar
2007/0087038 A1	4/2007	Richardson et al.	2008/0288038 A1	11/2008	Paul et al.
2007/0093710 A1	4/2007	Maschke	2008/0294041 A1	11/2008	Kassab
2007/0100236 A1	5/2007	McMorrow et al.	2008/0319350 A1	12/2008	Wallace et al.
2007/0100285 A1	5/2007	Griffin et al.	2009/0005674 A1	1/2009	Saadat et al.
2007/0112282 A1	5/2007	Skujins et al.	2009/0005675 A1*	1/2009	Grunwald et al. .... 600/424
2007/0123805 A1	5/2007	Shireman et al.	2009/0018497 A1	1/2009	Birchard et al.
2007/0129770 A1	6/2007	Younis	2009/0024018 A1*	1/2009	Boyden et al. .... 600/407
2007/0135803 A1	6/2007	Belson	2009/0030380 A1	1/2009	Binmoeller
2007/0135886 A1	6/2007	Maschke	2009/0043205 A1	2/2009	Pelissier et al.
2007/0156205 A1	7/2007	Larson et al.	2009/0062646 A1	3/2009	Creighton, IV et al.
2007/0161853 A1	7/2007	Yagi et al.	2009/0062684 A1	3/2009	Gregersen et al.
2007/0161914 A1	7/2007	Zdeblick et al.	2009/0082661 A1	3/2009	Saladin et al.
2007/0161915 A1	7/2007	Desai	2009/0084382 A1	4/2009	Jalde et al.
2007/0167738 A1	7/2007	Timinger et al.	2009/0101577 A1	4/2009	Fulkerson et al.
2007/0167762 A1	7/2007	Kim et al.	2009/0118612 A1	5/2009	Grunwald et al.
2007/0167769 A1	7/2007	Ikuma et al.	2009/0118637 A1	5/2009	Kassab et al.
2007/0167801 A1	7/2007	Webler et al.	2009/0118706 A1	5/2009	Schweikert et al.
2007/0167997 A1	7/2007	Forsberg et al.	2009/0124901 A1	5/2009	Fink et al.
2007/0197891 A1	8/2007	Shachar et al.	2009/0143736 A1	6/2009	Mittermeyer et al.
2007/0197905 A1	8/2007	Timinger et al.	2009/0156926 A1	6/2009	Messerly et al.
2007/0208255 A1	9/2007	Ridley et al.	2009/0163810 A1	6/2009	Kanade et al.
2007/0219453 A1	9/2007	Kremlivsky et al.	2009/0171217 A1	7/2009	Kim et al.
			2009/0177083 A1	7/2009	Matsumura
			2009/0177090 A1	7/2009	Grunwald et al.
			2009/0203989 A1	8/2009	Burnside et al.
			2009/0204113 A1	8/2009	MacAdam et al.

(56)

## References Cited

## U.S. PATENT DOCUMENTS

2009/0209872	A1	8/2009	Pop	2011/0112396	A1	5/2011	Shachar et al.
2009/0209950	A1	8/2009	Starksen	2011/0136242	A1	6/2011	Marx et al.
2009/0221908	A1	9/2009	Glossop	2011/0137156	A1	6/2011	Razzaque et al.
2009/0227952	A1	9/2009	Blakstvedt et al.	2011/0196235	A1	8/2011	Dunbar et al.
2009/0234328	A1	9/2009	Cox et al.	2011/0196248	A1	8/2011	Grunwald
2009/0253976	A1	10/2009	Harley et al.	2011/0196255	A1	8/2011	Kassab
2009/0258171	A1	10/2009	Uang	2011/0237935	A1	9/2011	Kalpin et al.
2009/0259124	A1	10/2009	Rothenberg	2011/0245659	A1	10/2011	Ma et al.
2009/0262982	A1	10/2009	Markowitz et al.	2011/0282187	A1	11/2011	Harley et al.
2009/0270729	A1	10/2009	Corbucci et al.	2011/0282188	A1	11/2011	Burnside et al.
2009/0270746	A1	10/2009	Min	2011/0282285	A1	11/2011	Blanchard et al.
2009/0275828	A1	11/2009	Shachar et al.	2011/0295108	A1	12/2011	Cox et al.
2009/0297441	A1	12/2009	Canham et al.	2011/0306867	A1	12/2011	Gopinathan et al.
2010/0004543	A1	1/2010	Ahlund et al.	2011/0313293	A1	12/2011	Lindekugel et al.
2010/0004547	A1	1/2010	Scholz et al.	2012/0004564	A1	1/2012	Dobak
2010/0010355	A1	1/2010	Kassab	2012/0035460	A1	2/2012	Stangenes et al.
2010/0010444	A1	1/2010	Bettuchi	2012/0046562	A1	2/2012	Powers et al.
2010/0010612	A1	1/2010	Gelbart et al.	2012/0059249	A1	3/2012	Verard et al.
2010/0016726	A1	1/2010	Meier	2012/0059270	A1	3/2012	Grunwald
2010/0036227	A1	2/2010	Cox et al.	2012/0071751	A1	3/2012	Sra et al.
2010/0036284	A1	2/2010	Laynes et al.	2012/0071759	A1	3/2012	Nagy et al.
2010/0041973	A1	2/2010	Vu et al.	2012/0071782	A1	3/2012	Patil et al.
2010/0041984	A1	2/2010	Shapland et al.	2012/0078342	A1	3/2012	Vollkron et al.
2010/0049062	A1	2/2010	Ziv	2012/0095319	A1	4/2012	Kondrosky et al.
2010/0055153	A1	3/2010	Majmudar	2012/0108950	A1	5/2012	He et al.
2010/0055184	A1	3/2010	Zeitels et al.	2012/0143029	A1	6/2012	Silverstein et al.
2010/0057157	A1	3/2010	Govari et al.	2012/0143078	A1	6/2012	Kassab et al.
2010/0060472	A1	3/2010	Kimura et al.	2012/0172727	A1	7/2012	Hastings et al.
2010/0063401	A1	3/2010	Nishina et al.	2012/0220854	A1	8/2012	Messerly et al.
2010/0076305	A1	3/2010	Maier-Hein et al.	2012/0283582	A1	11/2012	Mahapatra et al.
2010/0076328	A1	3/2010	Matsumura et al.	2012/0296200	A1	11/2012	Shachar et al.
2010/0081934	A1	4/2010	Soltani et al.	2012/0310052	A1	12/2012	Mahapatra et al.
2010/0083719	A1	4/2010	Peppmoller et al.	2012/0310066	A1	12/2012	Shachar et al.
2010/0094116	A1	4/2010	Silverstein	2012/0316440	A1	12/2012	Munrow et al.
2010/0106011	A1	4/2010	Byrd et al.	2013/0006102	A1	1/2013	Wilkes et al.
2010/0114573	A1	5/2010	Huang et al.	2013/0018248	A1	1/2013	Hurezan
2010/0117659	A1	5/2010	Osadchy et al.	2013/0035590	A1	2/2013	Ma et al.
2010/0130858	A1	5/2010	Arai et al.	2013/0041269	A1	2/2013	Stahmann et al.
2010/0143119	A1	6/2010	Kooijman et al.	2013/0060116	A1	3/2013	Messerly et al.
2010/0152596	A1	6/2010	Griffiths et al.	2013/0085416	A1	4/2013	Mest
2010/0168557	A1	7/2010	Deno et al.	2013/0102890	A1	4/2013	Dib
2010/0185097	A1	7/2010	Hall	2013/0123597	A1	5/2013	Rothenberg
2010/0198048	A1	8/2010	Togawa	2013/0169272	A1	7/2013	Eichler et al.
2010/0198346	A1	8/2010	Keogh et al.	2013/0217999	A1	8/2013	Burnside et al.
2010/0204569	A1	8/2010	Burnside et al.	2013/0245434	A1	9/2013	Messerly et al.
2010/0204614	A1	8/2010	Lindquist et al.	2013/0296691	A1	11/2013	Ashe
2010/0210938	A1	8/2010	Verard et al.	2013/0303896	A1	11/2013	Kalpin et al.
2010/0210950	A1	8/2010	Dunbar et al.	2013/0317338	A1	11/2013	Silverstein
2010/0217116	A1	8/2010	Eck et al.	2013/0324841	A1	12/2013	Kamen et al.
2010/0222786	A1	9/2010	Kassab	2013/0338503	A1	12/2013	Cohen et al.
2010/0234724	A1	9/2010	Jacobsen et al.	2013/0338517	A1	12/2013	Rothenberg
2010/0234733	A1	9/2010	Wahlheim	2013/0345555	A1	12/2013	Kanade et al.
2010/0249598	A1	9/2010	Smith et al.	2014/0031674	A1	1/2014	Newman et al.
2010/0258033	A1	10/2010	Yang et al.	2014/0046261	A1	2/2014	Newman et al.
2010/0268059	A1	10/2010	Ryu et al.	2014/0094694	A1	4/2014	Moctezuma de la Barrera
2010/0273895	A1	10/2010	Stinchcomb et al.	2014/0094768	A1	4/2014	Stangenes et al.
2010/0291521	A1	11/2010	Simon	2014/0107475	A1	4/2014	Cox et al.
2010/0298702	A1	11/2010	Rogers et al.	2014/0163356	A2	6/2014	Burnside et al.
2010/0298704	A1	11/2010	Pelissier et al.	2014/0180074	A1	6/2014	Green et al.
2010/0298705	A1	11/2010	Pelissier et al.	2014/0187990	A1	7/2014	Banet et al.
2010/0298712	A1	11/2010	Pelissier et al.	2014/0188133	A1	7/2014	Misener
2010/0312086	A9	12/2010	Beatty et al.	2014/0228689	A1	8/2014	Ishikawa et al.
2010/0317981	A1	12/2010	Grunwald	2014/0243659	A1	8/2014	Rothenberg
2010/0318026	A1	12/2010	Grunwald	2014/0257080	A1	9/2014	Dunbar et al.
2010/0331712	A1	12/2010	Rothenberg	2014/0275957	A1	9/2014	Lupotti
2011/0015527	A1	1/2011	Heasty et al.	2014/0275990	A1	9/2014	Hagy et al.
2011/0015533	A1	1/2011	Cox et al.	2014/0303492	A1	10/2014	Burnside et al.
2011/0034823	A1	2/2011	Gelbart et al.	2014/0309624	A1	10/2014	Bown et al.
2011/0034940	A1	2/2011	Payner	2014/0343398	A1	11/2014	He et al.
2011/0040212	A1	2/2011	Dietz et al.	2015/0005621	A1	1/2015	Liu
2011/0052694	A1	3/2011	Stinchcomb et al.	2015/0018701	A1	1/2015	Cox et al.
2011/0087105	A1	4/2011	Ridley et al.	2015/0025402	A1	1/2015	Rothenberg
2011/0087106	A1	4/2011	Ridley et al.	2015/0051489	A1	2/2015	Caluser et al.
2011/0087107	A1	4/2011	Lindekugel et al.	2015/0080716	A1	3/2015	Powers et al.
2011/0106101	A1	5/2011	Tortonese et al.	2015/0297114	A1	10/2015	Cox et al.
				2016/0374589	A1	12/2016	Misener et al.
				2017/0000367	A1	1/2017	Grunwald
				2017/0020561	A1	1/2017	Cox et al.
				2017/0079548	A1	3/2017	Silverstein et al.

(56)

## References Cited

## U.S. PATENT DOCUMENTS

2017/0079552 A1 3/2017 Grunwald  
 2017/0079615 A1 3/2017 Burnside et al.  
 2017/0079681 A1 3/2017 Burnside et al.  
 2017/0231700 A1 8/2017 Cox et al.

## FOREIGN PATENT DOCUMENTS

AU	1860597	B2	6/1999
AU	20009592		9/2000
AU	20015250		6/2001
AU	2001283703		5/2002
AU	768362	B2	12/2003
AU	2001229024	B2	9/2005
AU	2001283703	B2	5/2006
AU	2006202149		6/2006
AU	2006904933		9/2006
AU	2006283022	B2	2/2012
CA	2420676		2/2002
CA	2619909	C	1/2014
CN	2031655	U	2/1989
CN	1672649	A	9/2005
CN	1913833	A	2/2007
CN	102209490	A	10/2011
CN	102802514	A	11/2012
CN	102821679	A	12/2012
CN	103037761	A	4/2013
CN	103037762	A	4/2013
CN	103118591	A	5/2013
CN	103189009	A	7/2013
DE	4319033	C1	6/1994
EP	0359697		3/1990
EP	0362821		4/1990
EP	0399536		11/1990
EP	0823261	A2	2/1998
EP	0928976	A2	7/1999
EP	1025805	A1	8/2000
EP	1504713	A1	2/2005
EP	1717601	A2	11/2006
EP	1932477	A1	6/2008
EP	1311226	A1	8/2008
EP	2313143	A1	4/2011
EP	2337491	A1	6/2011
EP	2440122	A1	4/2012
EP	2464407	A2	6/2012
EP	2482719	A1	8/2012
EP	2575610	A1	4/2013
EP	2575611	A1	4/2013
EP	2603145	A2	6/2013
EP	2605699	A2	6/2013
EP	2618727	A1	7/2013
EP	2632360	A1	9/2013
EP	2219526	B1	3/2014
EP	2712547	A1	4/2014
FR	2545349		11/1984
IN	9721/DELNP/2011		1/2013
JP	01097440	A	4/1989
JP	03173542		7/1991
JP	4090741	U	8/1992
JP	4505748	T	10/1992
JP	9-503054		3/1997
JP	09-094298	A	4/1997
JP	10043310	A	2/1998
JP	10290839	A	11/1998
JP	11128237		5/1999
JP	2001-145630	A	5/2001
JP	2001161683		6/2001
JP	2001-514533	A	9/2001
JP	2001-524339	A	12/2001
JP	2001340334	A	12/2001
JP	2002-224069	A	8/2002
JP	2002-529133	A	9/2002
JP	2002-541947	A	12/2002
JP	2003-010138	A	1/2003
JP	2003501127	A	1/2003
JP	2003061752	A	3/2003
JP	2003299654		10/2003
JP	2003334191	A	11/2003
JP	2002520893		2/2004
JP	2004505748		2/2004
JP	2004515298	A	5/2004
JP	2006508744	A	3/2006
JP	2006-338526	A	12/2006
JP	2007-000226	A	1/2007
JP	2007-068989	A	3/2007
JP	2007-313122	A	12/2007
JP	2009/271123	A	11/2009
JP	5010604		6/2012
JP	2012-529929		11/2012
JP	2013-518676	A	5/2013
JP	2013-526959	A	6/2013
JP	2013-526961	A	6/2013
WO	1980002376	A1	11/1980
WO	WO-9002514	A1	3/1990
WO	9112836	A1	9/1991
WO	WO-9203090		3/1992
WO	WO-9404938		3/1994
WO	1996005768	A1	2/1996
WO	1996007352	A1	3/1996
WO	WO-9641119		12/1996
WO	1997029683	A1	8/1997
WO	1997043989	A1	11/1997
WO	97/48438	A2	12/1997
WO	1998025159	A1	6/1998
WO	98/29032	A1	7/1998
WO	1998035611	A1	8/1998
WO	199916495	A1	4/1999
WO	1999027837	A2	6/1999
WO	9949407	A1	9/1999
WO	WO-0019906		4/2000
WO	2000027281	A1	5/2000
WO	WO-0040155		7/2000
WO	2000063658	A2	10/2000
WO	2000074775	A1	12/2000
WO	2001013792	A1	3/2001
WO	2001039683	A1	6/2001
WO	2001076479	A1	10/2001
WO	02/07794	A2	1/2002
WO	WO-0215973		2/2002
WO	2002019905	A1	3/2002
WO	2002025277	A1	3/2002
WO	2002085442	A1	10/2002
WO	WO-02094102	A1	11/2002
WO	WO-2003061752		7/2003
WO	2003077759	A1	9/2003
WO	03/088833	A1	10/2003
WO	2003091495	A1	11/2003
WO	2004002303	A1	1/2004
WO	2004049970	A2	6/2004
WO	2005033574	A1	4/2005
WO	WO-05033524	A1	4/2005
WO	WO-05033574	A1	4/2005
WO	2005117690	A1	12/2005
WO	2005117733	A2	12/2005
WO	WO-06031765	A2	3/2006
WO	WO-2006031765	A3	3/2006
WO	WO-2006/074509	A1	7/2006
WO	WO-06074510	A1	7/2006
WO	WO-06078677	A2	7/2006
WO	WO-2006074510	A1	7/2006
WO	WO-2006078677	A2	7/2006
WO	2006103661	A2	10/2006
WO	2006111056	A1	10/2006
WO	2007002541	A2	1/2007
WO	2007005976	A1	1/2007
WO	2007014447	A1	2/2007
WO	2007034196	A2	3/2007
WO	2007067324	A1	6/2007
WO	2007069168	A2	6/2007
WO	2007109123	A2	9/2007
WO	2007126536	A2	11/2007
WO	2007144894	A1	12/2007
WO	2008005480	A1	1/2008
WO	2008024596	A2	2/2008
WO	WO-2008028253		3/2008

(56)

## References Cited

## FOREIGN PATENT DOCUMENTS

WO WO-2008/083111 A1 7/2008  
 WO 2008097767 A2 8/2008  
 WO 2008118992 A1 10/2008  
 WO 2008126074 A2 10/2008  
 WO 2008129326 A1 10/2008  
 WO 2008131017 A2 10/2008  
 WO 2008136008 A2 11/2008  
 WO 2009000439 A1 12/2008  
 WO 2009002514 A2 12/2008  
 WO 2009003138 A1 12/2008  
 WO 2009009064 A1 1/2009  
 WO 2009057774 A1 5/2009  
 WO 2009063166 A1 5/2009  
 WO 2009067654 A1 5/2009  
 WO 2009070616 A2 6/2009  
 WO WO-2009070836 6/2009  
 WO WO-2009100158 A1 8/2009  
 WO 2009123819 A2 10/2009  
 WO 2009126340 A1 10/2009  
 WO 2009129475 A1 10/2009  
 WO 2009129477 A1 10/2009  
 WO 2009134605 A2 11/2009  
 WO 2009137262 A2 11/2009  
 WO 2010002313 A1 1/2010  
 WO 2010018500 A1 2/2010  
 WO 2010022370 A1 2/2010  
 WO 2010027349 A1 3/2010  
 WO 2010027471 A2 3/2010  
 WO 2010029906 A1 3/2010  
 WO 2010030820 A1 3/2010  
 WO 2010132857 A1 11/2010  
 WO 2010132985 A1 11/2010  
 WO 2010143196 A1 12/2010  
 WO 2010144922 A1 12/2010  
 WO 2011019760 A2 2/2011  
 WO 2011041450 A1 4/2011  
 WO 2011044421 A1 4/2011  
 WO 2011057289 A2 5/2011  
 WO 2011064209 A1 6/2011  
 WO 2011084593 A2 7/2011  
 WO 2011097312 A1 8/2011  
 WO 2011128052 A2 10/2011  
 WO 2011150358 A1 12/2011  
 WO 2011150376 A1 12/2011  
 WO 2012021542 A2 2/2012  
 WO 2012024577 A2 2/2012  
 WO 2012039866 A1 3/2012  
 WO 2012040487 A1 3/2012  
 WO 2012058461 A1 5/2012  
 WO 2012083245 A1 6/2012  
 WO 2012088535 A1 6/2012  
 WO 2012110955 A1 8/2012  
 WO 2012173697 A1 12/2012  
 WO 2013006713 A2 1/2013  
 WO 2013006817 A1 1/2013  
 WO 2013034175 A1 3/2013  
 WO 2014052894 A2 4/2014  
 WO 2014062728 A1 4/2014  
 WO 2014138652 A1 9/2014  
 WO 2014138918 A1 9/2014  
 WO 2015/120256 A2 8/2015  
 WO 2016/210325 A1 12/2016

## OTHER PUBLICATIONS

Andropoulos, et al. "A Controlled Study of the Transesophageal Echocardiography to Guide Central Venous Catheter Placement in Congenital Heart Surgery Patients." *The International Anesthesia Research Society*, vol. 89, pp. 65-70, 1999.  
 Aslany, et al. "MRI of Central Venous Anatomy: Implications for Central Venous Catheter Insertion." *American College of Chest Physicians*, Jun. 8, 2009.

B.Braun Website, "The Optimal Position of the Central Venous Catheter." <http://www.cvcpartner.com/index.cfm18F1BDEA1310466194960A39F4E90968> (2009).  
 Cavatorta, et al., "Central Venous Catheter Placement in Hemodialysis: Evaluation of Electrocardiography Using a Guidewire." *The Journal of Vascular Access*, vol. 2, pp. 45-50, 2001.  
 Chaturvedi et al., "Catheter Malplacement During Central Venous Cannulation Through Arm Veins in Pediatric Patients." *Journal of Neurosurgical Anesthesiology*, vol. 15, No. 3 pp. 170-175, Jan. 2003.  
 Chu, et al., "Accurate Central Venous Port—A Catheter Placement: Intravenous Electrocardiography and Surface Landmark Techniques Compared by Using Transesophageal Echocardiography." *The International Anesthesia Research Society*, vol. 98, pp. 910-914, 2004.  
 Clifford, et al. "Assessment of Hepatic Motion Secondary to Respiration for Computer Assisted Interventions." *Computer Aided Surgery*, vol. 7, pp. 291-299, 2002.  
 Corsten, et al., "Central Placement Catheter Placement Using the ECG-Guided Cavafix-Certodyn SD Catheter." *Journal of Clinical Anesthesiology*, vol. 6, Nov./Dec. 1994.  
 David, et al., "Is ECG-Guidance a Helpful Method to Correctly Position a Central Venous Catheter During Prehospital Emergency Care?" *ACTA Anaesthesiologica Scandinavica*, vol. 49, pp. 1010-1014, 2005.  
 Deltec Cath-Finder® Tracking System Operation Manual, 1994.  
 Gebhard, et al., "The accuracy of Electrocardiogram-Controlled Central Line Placement." *The International Anesthesia Research Society*, vol. 104, No. 1 Jan. 2007.  
 Gonzales, et al. "Peripherally Inserted Central Catheter Placement in Swine Using Magnet Detection." *Journal of Intravenous Nursing*, vol. 22, No. 3, May/June. 1999.  
 Hoffmann, et al. "New Procedure in Transesophageal Echocardiography: Multiplane Transesophageal Echocardiography and Transesophageal Stress Echocardiography." *Herz*, vol. 18, No. 5, pp. 269-277, Oct. 1993.  
 Madan, et al. "Right Atrial Electrocardiography: A Technique for the Placement of Central Venous Catheters for Chemotherapy or Intravenous Nutrition." *British Journal of Surgery*, vol. B1, pp. 1604-1605, 1994.  
 McGee et al., "Accurate Placement of Central Venous Catheters: A Prospective, Randomize, Multicenter Trial." *Critical Care Medicine*, vol. 21 No. 8, Aug. 1993.  
 Microbird™ Miniaturized DC Magnetic Sensors for Intra-body Navigation and Localization, Specifications, 2005.  
 Pawlik, et al., "Central Venous Catheter Placement: Comparison of the Intravascular Guidewire and the Fluid Column Electrocardiograms." *European Journal of Anaesthesiology*, vol. 41, pp. 594-599, 2004.  
 Pittiruti, et al. "The EKG Method for Positioning the Tip of PICCs: Results from Two Preliminary Studies." *JAVA*, vol. 13, No. 4, pp. 179-185, 2008.  
 Sacolick, et al. "Electromagnetically Tracked Placement of a Peripherally Inserted Central Catheter." *SPIE Medical Imaging, 2004 Proceedings*.  
 Salem, et al. "A New Peripherally Implanted Subcutaneous Permanent Central Venous Access Device for Patients Requiring Chemotherapy." *Journal of Clinical Oncology*, vol. 11, No. 11, pp. 2181-2185, Nov. 1993.  
 Schafer et al. "Incorrect placement of a vena cava catheter and its prevention by intra-atrial ECG." *Anaesthetist*. Jan. 1988;37(1):49-51.  
 Schummer, et al. "Central Venous Catheters—The inability of 'intra-atrial ECG' to prove adequate positioning." *British Journal of Anaesthesia*, vol. 93, No. 2, pp. 193-198, 2004.  
 Simon, et al., "Central Venous Catheter Placement in Children: Evaluation of Electrocardiography Using J-Wire." *Paediatric Anaesthesia* vol. 9, pp. 501-504, 1999.  
 Stererotaxis Magnetic Navigation System with Navigant™ User Interface, 2005 Brochure.

(56)

## References Cited

## OTHER PUBLICATIONS

- Watters, et al. "Use of Electrocardiogram to Position Right Atrial Catheters During Surgery." *Annals of Surgery*, vol. 225, No. 2, pp. 165-171, 1997.
- Worley, Seth J. "Use of a Real-Time Three-Dimensional Magnetic Navigation System for Radiofrequency Ablation of Accessory Pathways." *PACE*, vol. 21 pp. 1636-1643, Aug. 1998.
- Zaaroor, et al. "Novel Magnetic Technology for Intraoperative Intracranial Frameless Navigation: In Vivo and In Vitro Results." *Neurosurgery*, vol. 48, No. 5, pp. 1100-1107, May 2001.
- Acuson—The Value of Vision, AcuNav Diagnostic Ultrasound Catheter, 2000.
- Advertising flyer for Gavecelt—the Italian Group for Long Term Venous Access Devices, for program on International Meeting on PICC's, Midline Catheters and Long Term Venous Access Devices in Catholic University, Rome, Italy on Dec. 3, 4, 5, 2008.
- Alexander, GD et al, The Role of Nitrous Oxide in Postoperative Nausea and Vomiting, Collection of Abstracts Presented at the International Anesthesia Research Society by various speakers, 58th Congress, Mar. 12-14, 1984, *Anesthesia and Analgesia*, pp. 175-284, vol. 63, 1984.
- Allan, P.L. et al, Role of Ultrasound in the Assessment of Chronic Venous Insufficiency, *Ultrasound Quarterly*, vol. 17, No. 1, pp. 3-10, 2001
- Anonymous author, Correct Catheter Placement with a low-impact, reliable and economical method, <<http://www.cvc-partner.com/index.cfm?103A955CC6844BF58ACFE3C9C1471959>>, last accessed Dec. 22, 2011.
- Arai, J et al, Detection of Peripherally Inserted Central Catheter Occlusion by in-line Pressure Monitoring, *Paediatr Anaesth*, pp. 621-624, vol. 12 No. 7, Sep. 2002.
- Arrow International, Inc., The Arrow-Johans RAECG Adapter-Making Proper Central Venous Catheter Placement More Reliable (Modle No. EG-04900), Technical Report 1987, USA.
- AU 2006283022 filed Aug. 24, 2006 Office Action dated Dec. 22, 2010.
- B. Braun, Certifix Central Venous Catheter for Placement Using the Seldinger Technique with Simultaneous ECG Lead Option, Feb. 2010.
- Bailey, SH et al, Is Immediate Chest Radiograph Necessary after Central Venous Catheter Placement in a Surgical Intensive Care Unit?, *Am J Surg*, pp. 517-522, vol. 180 No. 6, Dec. 2000.
- Bankier, Alexander A., Azygos Arch Cannulation by Central Venous Catheters: Radiographic Detection of Malposition and Subsequent Complications, *Journal of Thoracic Imaging* 12:64-69 (1997).
- Barber, JM et al, A Nurse led Peripherally Inserted Central Catheter Line Insertion Service is Effective with Radiological Support, *Clin Radiol*, pp. 352-354, vol. 57 No. 5, May 2002.
- Bard Access Systems, Sherlock Tip Location System, 5 pages, 2006.
- Bard Access Systems, Site Rite Vascular Access Ultrasound System, 4 pages, 2005.
- Benchimol, Alberto at al, Right Atrium and Superior Vena Cava Flow Velocity in Man Measured with the Doppler-Catheter Flowmeter-Telemetry System, *The Amer Journal of Medicine*, pp. 303-309, vol. 48, Mar. 1970.
- BioAdvance Lumen Vu, Greenhouse Fund Feb. 2004 Recipient, [www.bioadvance.com](http://www.bioadvance.com) <<http://www.bioadvance.com>>, 2005.
- Borgobello, Bridget, App allows users to view electrocardiograms on smartphones dated Oct. 15, 2010; printed from <http://www.gizmag.com/app-to-view-electrocardiograms-on-smartphones/16664/> on Feb. 4, 2011.
- Buehrle, Douglas, PICC Placement in Humans using Electromagnetic Detection, <[http://www.corpakmedsystems.com/supplement\\_material/supplementpages/navigator/navarticle.html](http://www.corpakmedsystems.com/supplement_material/supplementpages/navigator/navarticle.html)>, 2008.
- C.R. Bard, CathTrack™ Catheter Location System at [www.bardaccess.com](http://www.bardaccess.com) <<http://www.bardaccess.com>>, last accessed Apr. 28, 2011.
- C.R. Bard, Inc., Bard Electrophysiology Product Catalogue, Bard Catheters, pp. 74-75 (2002), USA.
- Cadman, A et al, To Clot or Not to Clot? That is the question in Central Venous Catheters, *Clinical Radiology*, pp. 349-355, vol. 59 No. 4, Apr. 2004.
- Calvert, N et al, The Effectiveness and Cost-effectiveness of Ultrasound Locating Devices for Central Venous Access: A Systematic Review and Economic Evaluation, *Health Technology Assessment*, vol. 7, No. 12, 2003.
- Cardella, John F. et al., Intervental Radiologic Placement of Peripherally Inserted Central Catheters, *Journal of Vascular and Interventional Radiology* 1993; 4:653-660.
- Carlson, R et al, Secondary Migration of a Central Venous Catheter—A Case Report, *Minerva Anestesiol*, pp. 927-931, vol. 69 No. 12, Dec. 2003.
- Caruso, LJ et al, A Better Landmark for Positioning a Central Venous Catheter, *J Clinical Monitoring and Computing*, pp. 331-334, vol. 17 No. 6, Aug. 2002.
- Chalkiadis, GA et al, Depth of Central Venous Catheter Insertion in Adults: An Audit and Assessment of a Technique to Improve Tip Position, *Anaesth Intensive Care*, pp. 61-66, vol. 26 No. 1, Feb. 1998.
- Chamsi-Pasha, Hassan et al, Cardiac Complications of Total Parenteral Nutrition: The Role of Two-Dimensional Echocardiography in Diagnosis, *Annals of the Royal College of Surgeons of England*, pp. 120-123, vol. 71, 1989.
- Chang, Thomas C. et al., Are Routine Ch Ladiographs Necessary After Image-Guided Placement of Internal Jugular Central Venous Access Devices?, *AJR* Feb. 1998;170:335-337.
- Chen, Zhongping et al, Optical Doppler Tomography: Imaging in vivo Blood Flow Dynamics Following Pharmacological Intervention and Photodynamic Therapy, 7 pages, vol. 67, *Photochemistry and Photobiology*, 1998.
- Cheng, KI et al, A Novel Approach of Intravenous Electrocardiograph Technique in Correct Position the Long-Term Central Venous Catheter, *Kaohsiung J Med Sci*, pp. 241-247, vol. 16 No. 5, May 2000 (Abstract only).
- Cheung, P., et al., The Effect of a Disposable Probe Cover on Pulse Oximetry, *Anaesth Intensive Care* 2002; 30: 211-214.
- Claasz, Antonia et al, A Study of the Relationship of the Superior Vena Cava to the Bony Landmarks of the Sternum in the Supine Adult: Implications for Magnetic Guidance Systems, *Journal*, vol. 12 No. 3, *JAVA*, Jul. 24, 2007.
- CN 200880012117.4 filed Apr. 16, 2008 First Office Action dated Dec. 23, 2011.
- Colley, Peter S et al, ECG-Guided Placement of Sorenson CVP Catheters via Arm Veins, *Anesthesia and Analgesia*, pp. 953-956, vol. 63, 1984.
- Collier, PE et al, Cardiac Tamponade from Central Venous Catheters, *Am J Surg*, pp. 212-214, vol. 176 No. 2, Aug. 1998.
- ComboWire® Pressure/Flow Guide Wire Ref 9500 Series, Instructions for Use, Apr. 2011.
- Cucchiara, Roy et al, Time Required and Success Rate of Percutaneous Right Atrial Catheterization: Description of a Technique, *Canad. Anaesth. Soc. J.*, pp. 572-573, vol. 27, No. 6, Nov. 1980.
- Cullinane, DC et al, The Futility of Chest Roentgenograms Following Routine Central Venous Line Changes, *Am J Surg*, pp. 283-285, vol. 176 No. 3, Sep. 1998.
- Curet, Myriam J. et al., University and Practice-based Physicians' Input on the Content of a Surgical Curriculum, *The American Journal of Surgery*® vol. 178 Jul. 1999, 78-84.
- Egelhof, Petra, Effects of Somatostatin on Portal Blood Flow and Portal Vein Pressure in Patients with Portal Hypertension due to Liver Cirrhosis Invasive Monitoring during TIPSS Procedures, Dissertation submitted to: Technical University of Munich, Faculty of Medicine, May 13, 2002; Date of examination: Feb. 26, 2003.
- Engelhardt, W et al, ECG-Controlled Placement of Central Venous Catheters in Patients with Atrial Fibrillation, *Anaesthesist*, pp. 476-479, vol. 38 No. 9, Sep. 1989 (Abstract only).
- EP 09808901.4 filed Aug. 21, 2009 European Search Report dated May 23, 2012.
- EP 09813632.8 filed Apr. 5, 2011 European Search Report dated Jul. 4, 2012.

(56)

## References Cited

## OTHER PUBLICATIONS

- Fearon, William F et al, Evaluating Intermediate Coronary Lesions in the Cardiac Catheterization Laboratory, vol. 4, No. 1, 7 pages, Reviews in Cardiovascular Medicine, 2003.
- Felleiter P et al, Use of Electrocardiographic Placement Control of Central Venous Catheters in Austria, Acta Med Austriaca, pp. 109-113, vol. 26 No. 3, 1999 (Abstract only).
- Forauer, AR et al, Change in Peripherally Inserted Central Catheter Tip Location with Abduction and Adduction of the Upper Extremity, J Vasc Interv Radiol, pp. 1315-1318, vol. 11 No. 10, Nov.-Dec. 2000.
- Frassinelli, P et al, Utility of Chest Radiographs after Guidewire Exchanges of Central Venous Catheters, Crit Care Med, pp. 611-615, vol. 26 No. 3, Mar. 1998.
- Frazin L et al, A Doppler Guided Retrograde Catheterization System, Cathet. Cardiovasc Diagn, pp. 41-50, May 1992.
- French, PJ et al, Sensors for Catheter Applications, Sensors Update, vol. 13 Issue 1 pp. 107-153, Dec. 2003.
- GB Application 0800474.9 filed Aug. 24, 2006 Office Action dated Aug. 9, 2010.
- Tepa® Health Innovation PC based ECG System Introduction and Technical Specifications, EKG Master USB, 2 pages, Nov. 2003.
- The FloWire Doppler Guide Wire located <<http://www.volcanocorp.com/products/flowire-doppler-guide-wire.php>>, 2011.
- UAB Health Systems, Arrhythmias, retrieved from <http://www.health.uab.edu/14564/> on Nov. 15, 2007, 12 pages.
- U.S. Appl. No. 11/466,602, filed Aug. 23, 2006 Advisory Action dated Jun. 22, 2009.
- U.S. Appl. No. 11/466,602, filed Aug. 23, 2006 Final Office Action dated Apr. 8, 2010.
- U.S. Appl. No. 11/466,602, filed Aug. 23, 2006 Final Office Action dated Jan. 30, 2009.
- U.S. Appl. No. 11/466,602, filed Aug. 23, 2006 Non-Final Office Action dated Sep. 25, 2009.
- U.S. Appl. No. 11/552,094, filed Oct. 23, 2006 Notice of Allowability dated Apr. 2, 2010.
- U.S. Appl. No. 11/552,094, filed Oct. 23, 2006 Non-Final Office Action dated Apr. 27, 2009.
- U.S. Appl. No. 11/552,094, filed Oct. 23, 2006 Notice of Allowance dated May 20, 2010.
- U.S. Appl. No. 12/104,253, filed Apr. 16, 2008 Final Office Action dated Jul. 27, 2011.
- U.S. Appl. No. 12/104,253, filed Apr. 16, 2008 Non-Final Office Action dated Nov. 29, 2010.
- U.S. Appl. No. 12/323,273, filed Nov. 25, 2008 Non-Final Office Action dated Jun. 8, 2012.
- U.S. Appl. No. 12/369,625, filed Feb. 11, 2009 Final Office Action dated Feb. 23, 2012.
- U.S. Appl. No. 12/369,625, filed Feb. 11, 2009 Non-Final Office Action dated Jul. 20, 2011.
- U.S. Appl. No. 12/427,244, filed Apr. 21, 2009 Non-Final Office Action dated Jan. 19, 2012.
- U.S. Appl. No. 12/557,401, filed Sep. 10, 2009 Non-Final Office Action dated Apr. 24, 2012.
- U.S. Appl. No. 12/878,915, filed Sep. 9, 2010 Non-Final Office Action dated Mar. 15, 2012.
- Valdivieso, J.R. Perez, et al., Evaluation of a formula for optimal positioning of a central venous catheter inserted through the right internal jugular vein, Rev. Esp. Anesthesiol. Reanim. 2003; 50: 77-79.
- VasoNova Inc, Vascular navigation system for accurate placement of PICCs, Start-Up Emerging Medical Ventures, pp. 44-45, vol. 14 No. 7, Jul.-Aug. 2009.
- Vesely, Thomas M. et al., Central Venous Catheter Tip Position: A Continuing Controversy, J Vasc Interv Radiol 2003; 14:527-534.
- Viasys Healthcare MedSystems, Navigator® Benefits, 2008.
- Viasys Healthcare MedSystems, Navigator® Research in Cost Justification, 2008.
- Volcano ComboMap Features and Benefits/Technical Specifications, 2 pages, 2011.
- Welch Allyn Cardioperfect® PC-Based Resting ECG, 2003.
- Wilson, R. G. et al, Right Atrial Electrocardiography in Placement of Central Venous Catheters, The Lancet, pp. 462-463, Feb. 27, 1988.
- Wong, Jeffrey J. et al., Azygos Tip Placement for Hemodialysis Catheters in Patients with Superior Vena Cava Occlusion, Cardiovasc Intervent Radiol (2006) 29:143-146.
- Yilmazlar A et al, Complications of 1303 Central Venous Cannulations, J R Soc Med, pp. 319-321, vol. 90 No. 6, Jun. 1997 (Abstract only).
- Yoon, SZ et al, Usefulness of the Carina as a Radiographic Landmark for Central Venous Catheter Placement in Paediatric Patients, Br J Anaesth, Jul. 2005.
- Yoshida, Teruhisa et al, Detection of Concealed Left Sided Accessory Atrioventricular Pathway by P Wave Signal Averaged Electrocardiogram, J Am Coll Cardiol, pp. 55-62, 1999.
- Zachariou, Zacharias et al., Intra-atrial ECG recording: a new and safe method for implanatation of Broviac catheters in children, Pediatr Surg Int (1994) 9: 457-458.
- PCT/US2009/041051 filed Apr. 17, 2009 Search Report dated Jul. 28, 2009.
- PCT/US2009/041051 filed Apr. 17, 2009 Written Opinion dated Jul. 28, 2009.
- PCT/US2009/054687 filed Aug. 21, 2009 International Preliminary Report on Patentability dated Feb. 22, 2011.
- PCT/US2009/054687 filed Aug. 21, 2009 Search Report dated Oct. 6, 2009.
- PCT/US2009/054687 filed Aug. 21, 2009 Written Opinion dated Oct. 6, 2009.
- PCT/US2009/056567 filed Sep. 10, 2009 International Preliminary Report on Patentability dated Mar. 15, 2011.
- PCT/US2009/056567 filed Sep. 10, 2009 Search Report dated Nov. 6, 2009.
- PCT/US2009/056567 filed Sep. 10, 2009 Written Opinion dated Nov. 6, 2009.
- PCT/US2010/038555 filed Jun. 14, 2010 Search Report dated Oct. 5, 2010.
- PCT/US2010/038555 filed Jun. 14, 2010 Written Opinion dated Oct. 5, 2010.
- PCT/US2010/045084 filed Aug. 10, 2010 International Preliminary Report on Patentability dated Feb. 23, 2012.
- PCT/US2010/045084 filed Aug. 10, 2010 Search Report dated Apr. 14, 2011.
- PCT/US2010/045084 filed Aug. 10, 2010 Written Opinion dated Apr. 14, 2011.
- PCT/US2010/050773 filed Sep. 29, 2010 Search Report dated Jan. 24, 2011.
- PCT/US2010/050773 filed Sep. 29, 2010 Written Opinion dated Jan. 24, 2011.
- PCT/US2010/051917 filed Oct. 8, 2010 Search Report dated Nov. 29, 2010.
- PCT/US2010/051917 filed Oct. 8, 2010 Written Opinion dated Nov. 29, 2010.
- PCT/US2011/023497 filed Feb. 2, 2011 Search Report dated Jun. 6, 2011.
- PCT/US2011/023497 filed Feb. 2, 2011 Written Opinion dated Jun. 6, 2011.
- PCT/US2011/038415 filed May 27, 2011 International Search Report dated Sep. 28, 2011.
- PCT/US2011/038415 filed May 27, 2011 Written Opinion dated Sep. 28, 2011.
- PCT/US2011/047127 filed Aug. 9, 2011 International Search Report dated Feb. 29, 2012.
- PCT/US2011/047127 filed Aug. 9, 2011 Written Opinion dated Feb. 29, 2012.
- PCT/US2011/048403 filed Aug. 19, 2011 International Search Report dated Dec. 15, 2011.
- PCT/US2011/048403 filed Aug. 19, 2011 Written Opinion dated Dec. 15, 2011.
- PCT/US2011/052793 filed Sep. 22, 2011 International Search Report dated Jan. 6, 2012.
- PCT/US2011/052793 filed Sep. 22, 2011 Written Opinion dated Jan. 6, 2012.

(56)

## References Cited

## OTHER PUBLICATIONS

- PCT/US2011/067268 filed Dec. 23, 2011 International Search Report and Written Opinion dated Apr. 27, 2012.
- Pennington, C.R., Right Atrial Thrombus: a Complication of Total Parenteral Nutrition, *British Medical Journal*, pp. 446-447, vol. 295, Aug. 15, 1987.
- Petersen, J et al, Silicone Venous Access Devices Positioned with their Tip High in the Superior Vena Cava are More Likely to Malfunction, *Am J Surg*, pp. 38-41, vol. 178 No. 1, Jul. 1999.
- Pittiruti, et al, Intracavitary EKG Monitoring: A reliable method for controlling tip position during and after PICC Insertion presentation in Catholic University, Rome, Italy in 2008.
- Polos, PG et al, Tips for Monitoring the Position of a Central Venous Catheter—How Placement can go awry—even when the anatomy is normal, *J Crit Illn*, pp. 660-674, vol. 8 No. 6, Jun. 1993 (Abstract only).
- Popp, M. B. et al., Accuracy of implanted port placement with the use of the electromagnetic CathTrack® catheter locator system, *The Journal of Vascular Access* 2005; 6: 9-12.
- Randolph AG et al, Ultrasound guidance for placement of central venous catheters: a meta-analysis of the literature, *Critical Care Medicine*, pp. 2053-2058, vol. 24, Dec. 1996.
- Reece, A et al, Positioning Long Lines: Contrast Versus Plain Radiography, *Arch Dis Child Fetal Neonatal Ed*, pp. 129-130, vol. 84 No. 2, Mar. 2001.
- Reynolds, N et al, Assessment of Distal Tip Position of Long Term Central Venous Feeding Catheters using Transesophageal Echocardiography, *JPEN J Parenter Enteral Nutr*, pp. 39-41, vol. 25 No. 1, Jan.-Feb. 2001.
- Ruschulte, Heiner et al, Prevention of Central Venous Catheter related infections with chlorhexidine gluconate impregnated wound dressings: A randomized controlled trial, presented as an abstract at the Annual meeting of the European Society of Anaesthesiologists (ESA) in Madrid, Spain in Jun. 2006, 12 pages, *Annals of Hematology*, Jul. 14, 2008.
- Rutherford, J. S. et al., Depth of Central Venous Catheterization: An Audit of Practice in a Cardiac Surgical Unit, *Anaesth Intens Care* 1994; 22: 267-271.
- Savary, D et al, Intra-atrial Monitoring to Add Insertion of a Central Venous Line in Pre-Hospital Emergency Care *Journal Europeen des Urgences*, pp. 75-78, vol. 17 No. 2, 2004.
- Schummer, W et al, ECG-guided Central Venous Catheter Positioning: Does it detect the Pericardial Reflection rather than the Right Atrium?, *Eur J Anaesthesiol*, pp. 600-605, vol. 21 No. 8, Aug. 2004 (Abstract only).
- Schummer, W et al, Intra-Atrial ECG is not a Reliable Method for Positioning Left Internal Jugular Vein Catheters, *Br J Anaesth*, pp. 481-486, vol. 91 No. 4, Oct. 2003.
- Schummer, W, Central Venous Catheter—the Inability of “Intra-Atrial ECG” to prove Adequate Positioning, *Br J Anaesth*, pp. 193-198, vol. 93 No. 2, Aug. 2004.
- Schuster, M. et al., The carina as a landmark in central venous catheter placement, *British Journal of Anaesthesia* 85 (2): 192-4 (2000).
- Siela, Debra, Using Chest Radiography in the Intensive Care Unit, *Crit Care Nurse* Aug. 1, 2002 vol. 22 No. 4, pp. 18-27.
- Smith, Brigham, et al., Intravenous electrocardiographic guidance for placement of peripherally inserted central catheters, *Journal of Electrocardiology* 43 (2010) 274-278.
- Stark, DD et al, Radiographic Assessment of Venous Catheter Position in Children: Value of the Lateral View, *Pediatric Radiology*, pp. 76-80, vol. 14 No. 2, 1984.
- Starkhammer, H et al, Central Venous Catheter Placement using Electromagnetic Position Sensing: A Clinical Evaluation, *Biomed. Instrum Technol*, vol. 30 No. 2, pp. 164-170; Mar.-Apr. 1996.
- Starr, David S et al, EKG Guided Placement of Subclavian CVP Catheters Using J-Wire, pp. 673-676, *Ann. Surg*, Dec. 1986.
- Stas, M et al, Peroperative Intravasal Electrographic Control of Catheter Tip Position in Access Ports Placed by Venous Cut-Down Technique, *EJSO*, pp. 316-320, vol. 27, 2001.
- Stereotaxis, Expanding the Possibilities of Interventional Medicine: Remote Navigation and Automation, pp. 1-8, Apr. 2011.
- GB Application 0800474.9 filed Aug. 24, 2006 Office Action dated Mar. 17, 2010.
- Gebauer, B et al, Ultrasound and Fluoroscopy-guided Implantation of Peripherally Inserted Central Venous Catheters (PICCs), *ROFO*, pp. 386-391, vol. 176 No. 3, Mar. 2004 (Abstract only).
- Gjendemsjo, Anders, et al., Energy and Power, The Connexions Project, Version 1.2, Feb. 20, 2004.
- Gladwin, MT et al, Cannulation of the Internal Jugular Vein: is postprocedural chest radiography always necessary?, *Crit Care Med*, 33 pages, Oct. 2000
- Greenall, M.J. et al, Cardiac Tamponade and Central Venous Catheters, *British Medical Journal*, pp. 595-597, Jun. 14, 1975.
- Guillory, “Basic Principles of Technologies for Catheter Localization.” C.R. Bard internal paper, Oct. 20, 2004.
- Guth, AA, Routine Chest X-rays after Insertion of Implantable Long-Term Venous Catheters: Necessary or Not?, *Am Surg*, pp. 26-29, vol. 67 No. 1, Jan. 2001 (Abstract only).
- Hill, Bradley et al, Abstract of article discussing VasaNova VPS as guide for placement of PICCs. 2009.
- Hill, Bradley, Identifying the Caval-Atrial Junction Using Smart-Catheter Technology presentation, 22nd Annual Scientific Meeting of the AVA in Savannah, Georgia, Sep. 13, 2008.
- Hoffman, Thomas et al, Simultaneous Measurement of Pulmonary Venous Flow by Intravascular Catheter Doppler Velocimetry and Transesophageal Doppler Echocardiography: Relation to Left Atrial Pressure and Left Atrial and Left Ventricular Function, pp. 239-249, *J Am Coll Cardiol*, Jul. 1995.
- Iacopino, Domenico Gerardo et al, Intraoperative Microvascular Doppler Monitoring of Blood Flow within a Spinal Dural Arteriovenous Fistula: A Precious Surgical Tool, vol. 10, 5 pages, *Neurosurg. Focus*, Feb. 2001.
- Joosting, Jean-Pierre, “Dual-interface RFID-compatible EEPROM enables remote access to electronic device parameters,” *EE Times*, Mar. 8, 2010.
- JP 2008-528151 filed Aug 24, 2006 Notice of Grant dated May 6, 2012.
- JP 2010-504220 filed Sep. 3, 2009 Office Action dated May 21, 2012.
- Kim, Ko et al, Positioning Internal Jugular Venous Catheters using the Right Third Intercostal Space in Children, *Acta Anaesthesiol Scand*, pp. 1284-1286, vol. 47 No. 10, Nov. 2003.
- Kjelstrup T et al, Positioning of Central Venous Catheters using ECG, *Tidssk Nor Laegeforen*, pp. 599-601, vol. 111 No. 5, Feb. 1999 (Abstract only).
- Koffler, Julia, et al., Epinephrine application via an endotracheal airway and via the Combitube in esophageal position, *Critical Care Medicine*: May 2000, vol. 28: Issue 5, pp. 1445-1449.
- Kowalski, CM et al, Migration of Central Venous Catheters: Implications for Initial Catheter Tip Positioning, *J Vasc Interv Radiol*, pp. 443-447, vol. 8 No. 3, May-Jun. 1997.
- Leowenthal, MR et al, The Peripherally Inserted Central Catheter (PICC): A Prospective Study of its Natural History after Fossa Insertion, *Anaesth Intensive Care*, pp. 21-24; vol. 30 No. 1, Feb. 2002.
- Lepage Ronan et al. ECG Segmentation and P-wave Feature Extraction: Application to Patients Prone to Atrial Fibrillation, *IEEE/EMBS Proceedings, 23rd Annual Conference, Istanbul, Turkey*, Oct. 25-28, 2001.
- Liu, Ji-Bin et al, Catheter-Based Intraluminal Sonography, *J Ultrasound Med*, pp. 145-160, vol. 23, 2004.
- Lucey, B et al, Routine Chest Radiographs after Central Line Insertion: Mandatory Postprocedural Evaluation or Unnecessary Waste of Resources?, *Cardiovasc Intervent Radiol*, pp. 381-384, vol. 22 No. 5, Sep.-Oct. 1999.
- Lum, Phillip, A New Formula-Based Measurement Guide for Optimal Positioning of Central Venous Catheters, *JAVA*, vol. 9, No. 2, pp. 80-85, 2004.
- Lynch, RE et al, A Procedure for Placing Pediatric Femoral Venous Catheter Tips near the Right Atrium, *Pediatr Emerg Care*, pp. 130-132, vol. 18 No. 2, Apr. 2002.

(56)

## References Cited

## OTHER PUBLICATIONS

- Madias, John E, Intracardiac (Superior Vena Cava/Right Atrial) ECGs using Saline Solution as the Conductive Medium for the Proper Positioning of the Shiley Hemodialysis Catheter: Is it Not Time to Forego the Postinsertion Chest Radiograph?, pp. 2363-2367, Chest, 2003.
- Markovich, Mary B., Central Venous Catheter Tip Placement: Determination of Posterior Malposition—A Case Study, *JAVA*, vol. 11, No. 2, pp. 85-89, 2006.
- Martin, Roy W, An Ultrasound Catheter for Intravascular Measurement of Blood Flow: Technical Details, *IEEE Transactions on Sonics and Ultrasonics*, vol. SU-27, No. 6, pp. 277-286, Nov. 1980.
- McDonnall, "Intra-Atrial Electrocardiography (ECG) for Catheter Placement." Literature review prepared for Bard Access Systems, Oct. 2007.
- MedGraphics, CardioPerfect® Resting/Stress ECG System, 3 pages, 2001.
- Michenfelder, John et al, Air Embolism During Neurosurgery—An Evaluation of Right-Atrial Catheters for Diagnosis and Treatment, *JAMA*, pp. 1353-1358, vol. 208, No. 8, May 26, 1969.
- Michenfelder, John et al, Air Embolism During Neurosurgery. A New Method of Treatment, Anesthesia and Analgesia. *Current Researches*, pp. 390-395, vol. 45, No. 4, Jul.-Aug. 1966.
- Micronix Pty Ltd "CathRite" Guiding Styled Core Manufacturing, Jun. 15, 2006.
- Murthy, Vrudhula et al, Analysis of Power Spectral Densities of Electrocardiograms, *Mathematical Biosciences*, pp. 41-51, vol. 12 No. 1-2, Oct. 1971.
- Nadroo, AM et al, Changes in Upper Extremity Position Cause Migration of Peripherally Inserted Central Catheters in Neonates, *Pediatrics*, pp. 131-136, vol. 110, Jul. 2002.
- Nakatani, K et al, Accurate Placement of Central Venous Catheters—ECG-guided method vs Patient Height Method, *Masui*, pp. 34-38, vol. 51 No. 1, Jan. 2002.
- Nazarian, GK et al, Changes in Tunneled Catheter Tip Position when a patient is Upright, *J Vasc Interv Radiol*, pp. 437-441, vol. 8 No. 3, May-Jun. 1997.
- Odd, De et al, Does Radio-opaque Contrast Improve Radiographic localisation of Percutaneous Central Venous Lines?, *Arch Dis Child Fetal Neonatal Ed*, pp. 41-43, vol. 89 No. 1, Jan. 2004.
- Palesty, JA et al, Routine Chest Radiographs Following Central Venous Recatheterization over a Wire are not Justified, *Am J Surg*, pp. 618-621, vol. 176 No. 6, Dec. 1998.
- Paliotti, Roberta P. et al, Intravascular Doppler Technique for Monitoring Renal Venous Blood Flow in Man, *J Nephrol*, pp. 57-62, 2003.
- Parker, K.H. et al, Cardiovascular Fluid Dynamics, Department of Bioengineering, National Heart and Lung Institute, Imperial College of Science, Technology and Medicine, Cardiovascular Haemodynamics, pp. 1-28, Sep. 26, 2005.
- PCT/US2006/033079 filed Aug. 24, 2006 International Preliminary Report on Patentability dated Feb. 26, 2008.
- PCT/US2006/033079 filed Aug. 24, 2006 Search Report dated Dec. 19, 2006.
- PCT/US2006/033079 filed Aug. 24, 2006 Written Opinion dated Dec. 19, 2006.
- PCT/US2008/060502 filed Apr. 16, 2008 International Search Report and Written Opinion dated Oct. 16, 2008.
- PCT/US2008/084751 filed Nov. 25, 2008 International Preliminary Report on Patentability dated Jun. 1, 2010.
- PCT/US2008/084751 filed Nov. 25, 2008 Search Report dated May 20, 2009.
- PCT/US2008/084751 filed Nov. 25, 2008 Written Opinion dated May 20, 2009.
- PCT/US2009/033116 filed Feb. 4, 2009 International Preliminary Report on Patentability dated Aug. 10, 2010.
- PCT/US2009/033116 filed Feb. 4, 2009 Search Report dated Mar. 13, 2009.
- PCT/US2009/033116 filed Feb. 4, 2009 Written Opinion dated Mar. 13, 2009.
- Aurora® System Technical Specifications, Oct. 2003.
- CN 200880125528.4 filed Nov. 25, 2008 First Office Action dated Jun. 5, 2012.
- EP 08855396.1 filed Jun. 15, 2010 European Search Report dated Jul. 31, 2012.
- Konings, MK, et al., Development of an intravascular impedance catheter for detection of fatty lesions in arteries, *Trans Med Imaging* Aug. 1997; 16(4):439-46. IEEE.
- MICRONIX CathRite™ Cardiac Access Device Brochure. Jun. 2004.
- NEUROMETER® CPT, Clinical Applications. Neurotron , Inc. website: [www.neurotron.com/CLINAPS.html](http://www.neurotron.com/CLINAPS.html), last accessed Oct. 23, 2006.
- NEUROMETER® CPT, Frequently Asked Questions. Neurotron , Inc. website: [www.neurotron.com/CPTFAQ/html](http://www.neurotron.com/CPTFAQ/html), last accessed Oct. 23, 2006.
- NEUROMETER® CPT, Products Page. Neurotron , Inc. website: [www.neurotron.com/products.html](http://www.neurotron.com/products.html), last accessed Oct. 23, 2006.
- NEUROMETER® Electrodiagnostic Neuroselective Sensory Nerve Evaluation: Charts, Tables, Documents & Downloads. Neurotron , Inc. website: [www.neurotron.com/downloads.html](http://www.neurotron.com/downloads.html), last accessed Oct. 23, 2006.
- PCT/US2011/058138 filed Oct. 27, 2011 International Search Report dated Feb. 7, 2012.
- PCT/US2011/058138 filed Oct. 27, 2011 Written Opinion dated Feb. 7, 2012.
- PCT/US2012/045814 filed Jul. 6, 2012 International Search Report and Written Opinion dated Oct. 1, 2012.
- Pop, Gheorghe A. et al., Catheter-based impedance measurements in the right atrium for continuously monitoring hematocrit and estimating blood viscosity changes; an in vivo feasibility study in swine, *Biosensors and Bioelectronics* 19 (2004) 1685-1693.
- Starkhammar et al. "Cath-Finder Catheter Tracking System: A New Device for Positioning of Central Venous Catheters. Early Experience from Implantation of Brachial portal Systems." *Acta Anaesthesiol Scandinavia*, vol. 34, No. 4 pp. 296-300, May 1990.
- Traxal Technologies, Tracking Technology website overview: [www.traxal.com/rd/rd\\_classroom\\_trackingtechnology.htm](http://www.traxal.com/rd/rd_classroom_trackingtechnology.htm), last accessed Dec. 1, 2006.
- U.S. Appl. No. 11/466,602, filed Aug. 23, 2006 Appeal Board Decision dated Sep. 17, 2012.
- U.S. Appl. No. 12/369,625, filed Feb. 11, 2009 Notice of Allowance dated Oct. 5, 2012.
- U.S. Appl. No. 12/715,556, filed Mar. 2, 2010 Non-Final Office Action dated Sep. 13, 2012.
- U.S. Appl. No. 12/878,915, filed Sep. 9, 2010 Final Office Action dated Sep. 26, 2012.
- U.S. Appl. No. 13/118,138, filed May 27, 2011 Non-Final Office Action dated Oct. 3, 2012.
- U.S. Appl. No. 13/213,622, filed Aug. 19, 2011 Non-Final Office Action dated Jul. 31, 2012.
- U.S. Appl. No. 13/336,919, filed Dec. 23, 2011 Non-Final Office Action dated Oct. 16, 2012.
- VIASYS Health Care Inc. Cortrak © Fact Sheet, 2005.
- VIASYS MedSystems, Cortrak™ Systems Brochure, 2005.
- U.S. Appl. No. 12/900,750, filed Oct. 8, 2010 Non-Final Office Action dated Jun. 3, 2013.
- U.S. Appl. No. 13/019,939, filed Feb. 2, 2011 Non-Final Office Action dated Oct. 11, 2013.
- U.S. Appl. No. 13/118,138, filed May 27, 2011 Final Office Action dated Apr. 3, 2013.
- U.S. Appl. No. 13/118,138, filed May 27, 2011 Final Office Action dated Aug. 1, 2013.
- U.S. Appl. No. 13/213,622, filed Aug. 19, 2011 Final Office Action dated Feb. 19, 2013.
- U.S. Appl. No. 13/283,395, filed Oct. 27, 2011 Non-Final Office Action dated Apr. 23, 2013.
- U.S. Appl. No. 13/336,919, filed Dec. 23, 2011 Advisory Action dated May 23, 2013.
- U.S. Appl. No. 13/336,919, filed Dec. 23, 2011 Final Office Action dated Mar. 1, 2013.
- U.S. Appl. No. 13/336,919, filed Dec. 23, 2011 Non-Final Office Action dated Dec. 27, 2013.

(56)

## References Cited

## OTHER PUBLICATIONS

- U.S. Appl. No. 13/337,987, filed Dec. 27, 2011 Non-Final Office Action dated Mar. 15, 2013.
- U.S. Appl. No. 13/469,932, filed May 11, 2012 Non-Final Office Action dated Jan. 3, 2014.
- U.S. Appl. No. 13/665,420, filed Oct. 31, 2012 Non-Final Office Action dated Jan. 6, 2014.
- U.S. Appl. No. 29/428,649, filed Aug. 1, 2012 Notice of Allowance dated Jul. 5, 2013.
- AU 2008329807 exam requested Aug. 13, 2012 Examination Report No. 1 dated Feb. 15, 2013.
- AU 2011289513 filed Jan. 21, 2013 Examiners Report dated Jul. 5, 2013.
- AU 2012202293 filed Apr. 19, 2012 Examination Report No. 1 dated Apr. 24, 2013.
- AU 2013201648 filed Mar. 19, 2013 Examiners Report dated Oct. 14, 2013.
- AU 2013204243 filed Apr. 12, 2013 Examiner's Report dated Jun. 5, 2013.
- CA 2,619,909 filed Aug. 24, 2006 Examiner's Report dated Oct. 26, 2012.
- CN 200880012117.4 filed Apr. 16, 2008 Second Office Action dated Oct. 8, 2012.
- CN 200880012117.4 filed Apr. 16, 2008 Third Office Action dated Apr. 27, 2013.
- CN 200880125528.4 filed Nov. 25, 2008 Second Office Action dated Mar. 6, 2013.
- CN 200880125528.4 filed Nov. 25, 2008 Third Office Action dated Jul. 1, 2013.
- CN 200980123021.X filed Dec. 17, 2010 First Office Action dated Nov. 19, 2012.
- CN 200980123021.X filed Dec. 17, 2010 Second Office Action dated Aug. 13, 2013.
- CN 200980144663.8 filed May 9, 2011 First Office Action dated Dec. 5, 2012.
- CN 200980144663.8 filed May 9, 2011 Second Office Action dated Aug. 22, 2013.
- EP 08855396.1 filed Jun. 15, 2010 Intent to Grant dated Jul. 5, 2013.
- EP 09707467.8 supplemental European search report dated Jun. 18, 2013.
- EP 09808901.4 filed Aug. 21, 2009 Examination Report dated May 10, 2013.
- EP 09813632.8 filed Apr. 5, 2011 Office Action dated Apr. 30, 2013.
- EP 12177438.4 filed Jul. 23, 2012 Communication dated Jan. 13, 2014.
- EP 12177438.4 filed Jul. 23, 2012 European Search Report dated Dec. 4, 2012.
- EP 12177438.4 filed Jul. 23, 2012 extended European Search Report dated Mar. 25, 2013.
- JP 2010-504220 filed Sep. 3, 2009 Final Office Action dated Apr. 18, 2013.
- JP 2010-535117 filed May 26, 2011 First Office Action dated Aug. 5, 2013.
- PCT/US13/62409 filed Sep. 27, 2013 International Search Report and Written Opinion dated Feb. 24, 2014.
- PCT/US2011/038391 filed May 27, 2011 International Preliminary Report on Patentability and Written Opinion dated Dec. 4, 2012.
- PCT/US2011/038391 filed May 27, 2011 International Search Report dated Sep. 21, 2011.
- PCT/US2011/038415 filed May 27, 2011 International Preliminary Report on Patentability dated Dec. 13, 2012.
- PCT/US2011/047127 filed Aug. 9, 2011 International Preliminary Report on Patentability dated Apr. 18, 2013.
- PCT/US2011/052793 filed Sep. 22, 2011 International Preliminary Report on Patentability dated Apr. 4, 2013.
- PCT/US2011/058138 filed Oct. 27, 2011 International Preliminary Report on Patentability dated May 10, 2013.
- PCT/US2011/067268 filed Dec. 23, 2011 International Preliminary Report on Patentability dated Jul. 4, 2013.
- PCT/US2013/065121 filed Oct. 15, 2013 International Search Report and Written Opinion dated Jan. 16, 2014.
- U.S. Appl. No. 11/466,602, filed Aug. 23, 2006 Final Office Action dated Oct. 28, 2013.
- U.S. Appl. No. 11/466,602, filed Aug. 23, 2006 Non-Final Office Action dated Mar. 28, 2013.
- U.S. Appl. No. 11/466,602, filed Aug. 23, 2006 Notice of Allowance dated Dec. 3, 2012.
- U.S. Appl. No. 12/426,175, filed Apr. 17, 2009 Advisory Action dated Nov. 26, 2013.
- U.S. Appl. No. 12/426,175, filed Apr. 17, 2009 Final Office Action dated Aug. 2, 2013.
- U.S. Appl. No. 12/426,175, filed Apr. 17, 2009 Final Office Action dated Jan. 31, 2014.
- U.S. Appl. No. 12/426,175, filed Apr. 17, 2009 Non-Final Office Action dated Dec. 3, 2012.
- U.S. Appl. No. 12/557,401, filed Sep. 10, 2009 Non-Final Office Action dated Jan. 6, 2014.
- U.S. Appl. No. 12/575,456, filed Oct. 7, 2009 Non-Final Office Action dated Oct. 5, 2012.
- U.S. Appl. No. 12/715,556, filed Mar. 2, 2010 Final Office Action dated Oct. 2, 2013.
- U.S. Appl. No. 12/815,331, filed Jun. 14, 2010 Advisory Action dated Oct. 4, 2013.
- U.S. Appl. No. 12/815,331, filed Jun. 14, 2010 Final Office Action dated Jul. 26, 2013.
- U.S. Appl. No. 12/815,331, filed Jun. 14, 2010 Non-Final Office Action dated Jan. 22, 2013.
- U.S. Appl. No. 12/854,083, filed Aug. 10, 2010 Final Office Action dated Aug. 15, 2013.
- U.S. Appl. No. 12/854,083, filed Aug. 10, 2010 Non-Final Office Action dated Jan. 29, 2013.
- U.S. Appl. No. 12/854,083, filed Aug. 10, 2010 Non-Final Office Action dated Jan. 29, 2014.
- U.S. Appl. No. 12/878,915, filed Sep. 9, 2010 Notice of Allowance dated Jan. 8, 2013.
- U.S. Appl. No. 12/893,916, filed Sep. 29, 2010 Non-Final Office Action dated Dec. 24, 2013.
- AU 2008329807 exam requested Aug. 13, 2012 Notice of Acceptance dated Feb. 14, 2014.
- AU 2010300677 filed Mar. 12, 2012 First Examination Report dated Mar. 9, 2014.
- AU 2013201648 filed Mar. 19, 2013 Examiner's Report dated Mar. 5, 2014.
- AU 2013202824 filed Apr. 6, 2013 First Examiner's Report dated Mar. 10, 2014.
- Benzadon, M. N. et al: "Comparison of the Amplitude of the P-Wave from Intracardiac Electrocardiogram Obtained by Means of a Central Venous Catheter Filled With Saline Solution to That Obtained Via Esophageal Electrocardiogram", American Journal of Cardiology, Cahners Publishing Co., Newton, MA, US, vol. 98, No. 7, Oct. 1, 2006 (Oct. 1, 2006), pp. 978-981.
- CN 200980123021.X filed Dec. 17, 2010 Third Office Action dated Apr. 22, 2014.
- CN 200980144663.8 filed May 9, 2011 Third Office Action dated May 4, 2014.
- CN 201080035659.0 filed Feb. 10, 2012 First Office Action dated Jan. 26, 2014.
- CN 201080035659.0 filed Feb. 10, 2012 Second Office Action dated Oct. 9, 2014.
- CN 201080053838.7 filed May 28, 2012 First Office Action dated Jan. 6, 2014.
- CN 201080053838.7 filed May 28, 2012 Second Office Action dated Jun. 17, 2014.
- CN 201180016462.7 filed Sep. 27, 2012 First Office Action dated Mar. 21, 2014.
- CN 201180037065.8 filed Jan. 28, 2013 First Office Action dated Sep. 28, 2014.
- CN 201180037068.1 filed Jan. 28, 2013 First Office Action dated Sep. 9, 2014.
- CN 201180043512.0 filed Mar. 8, 2013 First Office Action dated Jul. 31, 2014.

(56)

## References Cited

## OTHER PUBLICATIONS

- CN 201180068309.9 filed Aug. 22, 2013 First Office Action dated Oct. 16, 2014.
- EP 09813632.8 filed Apr. 5, 2011 Summons to Attend Oral Proceedings dated Apr. 16, 2014.
- EP 10 808 660.4 filed Feb. 15, 2012 Extended European Search Report dated Mar. 4, 2014.
- EP 10786978.6 filed Dec. 19, 2011 Extended European Search Report dated Mar. 7, 2014.
- EP 11 818 828.3 filed Mar. 18, 2013 Extended European Search Report dated Dec. 10, 2014.
- EP 12177438.4 filed Jul. 23, 2012 Examination Report dated Dec. 5, 2014.
- EP 13194818.4 filed Nov. 28, 2013 extended European search report dated Feb. 28, 2014.
- EP 14151268.1 filed Jan. 15, 2014 European Search Report dated Feb. 21, 2014.
- Jeon, Yunseok et al., "Transesophageal Echocardiographic Evaluation of ECG-guided Central Venous Catheter Placement," Canadian Journal of Anesthesia, vol. 53, No. 10, Oct. 1, 2006, pp. 978-983.
- JP 2012-515222 filed Dec. 9, 2011 Office Action dated Mar. 24, 2014.
- JP 2012-552060 filed Aug. 1, 2012 Office Action dated Nov. 12, 2014.
- MX/a/2012/013858 filed Nov. 28, 2012 First Office Action dated Sep. 26, 2014.
- PCT/US2009/041051 filed Apr. 17, 2009 International Preliminary Report on Patentability dated Apr. 8, 2014.
- PCT/US2011/048403 filed Aug. 19, 2011 International Preliminary Report on Patentability dated Jul. 30, 2013.
- PCT/US2014/022019 filed Mar. 7, 2014 International Search Report and Written Opinion dated Jun. 11, 2014.
- RU 2011150917 filed Dec. 15, 2011 First Office Action dated Apr. 24, 2014.
- RU 2011150917 filed Dec. 15, 2011 Second Office Action dated Aug. 28, 2014.
- U.S. Appl. No. 11/466,602, filed Aug. 23, 2006 Notice of Allowance dated Mar. 14, 2014.
- U.S. Appl. No. 12/426,175, filed Apr. 17, 2009 Examiners Answer dated Oct. 7, 2014.
- U.S. Appl. No. 12/815,331, filed Jun. 14, 2010 Final Office Action dated Dec. 23, 2014.
- U.S. Appl. No. 12/815,331, filed Jun. 14, 2010 Non-Final Office Action dated Jul. 2, 2014.
- U.S. Appl. No. 12/854,083, filed Aug. 10, 2010 Advisory Action dated Sep. 8, 2014.
- U.S. Appl. No. 12/854,083, filed Aug. 10, 2010 Final Office Action dated Jul. 1, 2014.
- U.S. Appl. No. 12/893,916, filed Sep. 29, 2010 Advisory Action dated Aug. 15, 2014.
- U.S. Appl. No. 12/893,916, filed Sep. 29, 2010 Final Office Action dated Jun. 18, 2014.
- U.S. Appl. No. 12/893,916, filed Sep. 29, 2010 Non-Final Office Action dated Sep. 25, 2014.
- U.S. Appl. No. 13/019,939, filed Feb. 2, 2011 Final Office Action dated Apr. 2, 2014.
- U.S. Appl. No. 13/118,033, filed May 27, 2011 Non-Final Office Action dated May 22, 2014.
- U.S. Appl. No. 13/118,138, filed May 27, 2011 Non-Final Office Action dated Oct. 9, 2014.
- U.S. Appl. No. 13/213,622, filed Aug. 19, 2011 Non-Final Office Action dated May 22, 2014.
- U.S. Appl. No. 13/240,171, filed Sep. 22, 2011 Non-Final Office Action dated Dec. 26, 2014.
- U.S. Appl. No. 13/336,919, filed Dec. 23, 2011 Final Office Action dated Dec. 19, 2014.
- U.S. Appl. No. 13/469,932, filed May 11, 2012 Non-Final Office Action dated Jul. 31, 2014.
- U.S. Appl. No. 13/665,420, filed Oct. 31, 2012 Non-Final Office Action dated Oct. 9, 2014.
- U.S. Appl. No. 13/737,806, filed Jan. 9, 2013 Notice of Allowance dated Oct. 31, 2013.
- U.S. Appl. No. 13/887,166, filed May 3, 2013 Advisory Action dated Aug. 27, 2014.
- U.S. Appl. No. 13/887,166, filed May 3, 2013 Final Office Action dated Jun. 23, 2014.
- U.S. Appl. No. 13/887,166, filed May 3, 2013 Non-Final Office Action dated Jan. 7, 2014.
- U.S. Appl. No. 13/890,158, filed May 8, 2013 Non-Final Office Action dated Aug. 15, 2014.
- U.S. Appl. No. 13/969,265, filed Aug. 16, 2013 Non-Final Office Action dated Dec. 19, 2013.
- U.S. Appl. No. 13/969,265, filed Aug. 16, 2013 Notice of Allowance dated Jun. 23, 2014.
- U.S. Appl. No. 14/141,046, filed Dec. 26, 2013 Non-Final Office Action dated Jun. 20, 2014.
- U.S. Appl. No. 14/317,501, filed Jun. 27, 2014 Non-Final Office Action dated Sep. 12, 2014.
- Zaidi, Naveed A., et al. "Room temperature magnetic order in an organic magnet derived from polyaniline." 2004, Polymer, vol. 45, pp. 5683-5689.
- CN 200980144663.8 filed May 9, 2011 Fifth Office Action dated May 26, 2015.
- CN 200980144663.8 filed May 9, 2011 Fourth Office Action dated Nov. 15, 2014.
- CN 201080035659.0 filed Feb. 10, 2012 Third Office Action dated Mar. 19, 2015.
- CN 201080053838.7 filed May 28, 2012 Fourth Office Action dated Jun. 2, 2015.
- CN 201080053838.7 filed May 28, 2012 Third Office Action dated Dec. 4, 2014.
- CN 201180016462.7 filed Sep. 27, 2012 Second Office Action dated Dec. 9, 2014.
- CN 201180016462.7 filed Sep. 27, 2012 Third Office Action dated Jun. 10, 2015.
- CN 201180037065.8 filed Jan. 28, 2013 First Office Action dated Jun. 2, 2015.
- CN 201180037068.1 filed Jan. 28, 2013 First Office Action dated Apr. 20, 2015.
- CN 201180040151.4 filed Feb. 19, 2013 First Office Action dated Oct. 28, 2014.
- CN 201180040151.4 filed Feb. 19, 2013 Second Office Action dated Jun. 19, 2015.
- CN 201180043512.0 filed Mar. 8, 2013 Second Office Action dated Apr. 14, 2015.
- CN 201180052587.5 filed Apr. 28, 2013 First Office Action dated Jan. 26, 2015.
- CN 201180068309.9 filed Aug. 22, 2013 Second Office Action dated May 6, 2015.
- EP 11787515.3 filed Dec. 12, 2012 partial European search report dated Jun. 23, 2015.
- EP 11787527.8 filed Dec. 19, 2012 partial European search report dated May 26, 2015.
- EP 11837113.7 filed May 28, 2013 Extended European Search Report dated Apr. 24, 2014.
- EP 12177438.4 filed Jul. 23, 2012 European Search Report dated Jun. 7, 2015.
- EP 12807886.2 filed Jan. 15, 2014 Extended European Search Report dated February 6, 2015.
- EP14197136.6 filed Dec. 10, 2014 Extended European Search Report dated May 26, 2015.
- JP 2012-515222 filed Dec. 9, 2011 Office Action dated Feb. 23, 2015.
- JP 2013-512046 filed Nov. 26, 2012 First Office Action dated Mar. 23, 2015.
- JP 2013-512051 filed Nov. 26, 2012 First Office Action dated Mar. 23, 2015.
- JP 2013-524999 filed Jan. 22, 2013 First Office Action dated Jun. 1, 2015.
- Moureau, Nancy L. et al., "Electrocardiogram (EKG) Guided Peripherally Inserted Central Catheter Placement and Tip Position:

(56)

## References Cited

## OTHER PUBLICATIONS

Results of a Trial to Replace Radiological Confirmation,” Journal of the Association for Vascular Access, pp. 8-14, vol. 15, No. 1, 2010. MX/a/2012/013858 filed Nov. 28, 2012 Second Office Action dated Jun. 10, 2015.

Pittiruti, et al, “The intracavitary ECG method for positioning the tip of central venous catheters: results of an Italian multicenter study,” J Vasc Access, pp. 1-9, Nov. 21, 2011.

Pittiruti, et al. “The electrocardiographic method for positioning the tip of central venous catheters” JAVA, pp. 1-12, Feb. 12, 2011.

U.S. Appl. No. 1/118,033, filed May 27, 2011 Non-Final Office Action dated Jul. 8, 2015.

U.S. Appl. No. 12/815,331, filed Jun. 14, 2010 Advisory Action dated Mar. 5, 2015.

U.S. Appl. No. 12/815,331, filed Jun. 14, 2010 Non-Final Office Action dated Jun. 1, 2015.

U.S. Appl. No. 12/854,083, filed Aug. 10, 2010 Non-Final Office Action dated Mar. 16, 2015.

U.S. Appl. No. 12/893,916, filed Sep. 29, 2010 Final Office Action dated Jan. 15, 2015.

U.S. Appl. No. 13/019,939, filed Feb. 2, 2011 Non-Final Office Action dated Feb. 9, 2015.

U.S. Appl. No. 13/118,033, filed May 27, 2011 Non-Final Office Action dated Feb. 3, 2015.

U.S. Appl. No. 13/118,138, filed May 27, 2011 Non-Final Office Action dated Jul. 15, 2015.

U.S. Appl. No. 13/240,171, filed Sep. 22, 2011 Final Office Action dated Jun. 10, 2015.

U.S. Appl. No. 13/283,395, filed Oct. 27, 2011 Advisory Action dated Jan. 28, 2014.

U.S. Appl. No. 13/283,395, filed Oct. 27, 2011 Final Office Action dated Nov. 14, 2013.

U.S. Appl. No. 13/336,919, filed Dec. 23, 2011 Non-Final Office Action dated Jul. 9, 2015.

U.S. Appl. No. 13/887,166, filed May 3, 2013 Examiner’s Answer dated Jul. 16, 2015.

U.S. Appl. No. 14/141,046, filed Dec. 26, 2013 Non-Final Office Action dated Feb. 11, 2015.

U.S. Appl. No. 14/270,241, filed May 5, 2014 Non-Final Office Action dated Apr. 23, 2015.

U.S. Appl. No. 14/317,501, filed Jun. 27, 2014 Final Office Action dated Jul. 1, 2015.

U.S. Appl. No. 14/317,501, filed Jun. 27, 2014 Non-Final Office Action dated Mar. 3, 2015.

U.S. Appl. No. 14/449,061, filed Jul. 31, 2014 Non-Final Office Action dated Apr. 27, 2015.

U.S. Appl. No. 14/548,151, filed Nov. 19, 2014 Non-Final Office Action dated Jun. 5, 2015.

CA 2,721,715 filed Apr. 17, 2009 Examiner’s Report dated Aug. 18, 2015.

CN 201180037068.1 filed Jan. 28, 2013 Third Office Action dated Oct. 19, 2015.

CN 2011800525875 filed Apr. 28, 2013 Second Office Action dated Aug. 19, 2015.

CN 201180068309.9 filed Aug. 22, 2013 Third Office Action dated Sep. 2, 2015.

EP 10821193.9 filed Mar. 27 2012 Partial European Search Report dated Oct. 9, 2015.

EP 11787515.3 filed Dec. 12, 2012 partial European search report dated Oct. 27, 2015.

EP 11787527.8 filed Dec. 19 2012 Extended European Search Report dated Oct. 9, 2015.

JP 2012-552060 filed Aug. 1, 2012 Second Office Action dated Nov. 6, 2015.

MX/a/2012/013672 filed Nov. 23, 2012 First Office Action dated Aug. 10, 2015.

U.S. Appl. No. 12/815,331, filed Jun. 14, 2010 Final Office Action dated Nov. 4, 2015.

U.S. Appl. No. 12/854,083, filed Aug. 10, 2010 Final Office Action dated Aug. 21, 2015.

U.S. Appl. No. 12/893,916, filed Sep. 29, 2010 Non-Final Office Action dated Sep. 10, 2015.

U.S. Appl. No. 13/240,171, filed Sep. 22, 2011 Advisory Action dated Aug. 18, 2015.

U.S. Appl. No. 13/469,932, filed May 11, 2012 Non-Final Office Action dated Sep. 4, 2015.

U.S. Appl. No. 13/665,420, filed Oct. 31, 2012 Non-Final Office Action dated Jul. 9, 2015.

U.S. Appl. No. 13/890,158, filed May 8, 2013 Non-Final Office Action dated Jul. 9, 2015.

U.S. Appl. No. 14/141,046, filed Dec. 26, 2013 Non-Final Office Action dated Nov. 05, 2015.

U.S. Appl. No. 14/270,241, filed May 5, 2014 Notice of Allowance dated Oct. 7, 2015.

U.S. Appl. No. 14/309,511, filed Jun. 19, 2014 Non-Final Office Action, dated Sep. 24, 2015.

U.S. Appl. No. 14/317,501, filed Jun. 27, 2014 Advisory Action dated Sep. 16, 2015.

U.S. Appl. No. 14/449,061, filed Jul. 31, 2014 Final Office Action dated Nov. 6, 2015.

U.S. Appl. No. 14/506,552, filed Oct. 3, 2014 Non-Final Office Action dated Oct. 1, 2015.

CN 200980144663.8 filed May 9, 2011 Decision of Re-Examination dated Feb. 21, 2017.

CN 201510144728.6 filed Apr 17, 2015 Office Action dated Jan. 23, 2017.

CO 15110530 filed May 14, 2015 Office Action dated Nov. 25, 2016.

EP 09743249.6 filed Oct. 18, 2010 Intention to Grant dated Mar. 2, 2017.

EP 13846380.7 filed May 15, 2015 Extended European Search Report dated Sep. 30, 2016.

U.S. Appl. No. 12/426,175, filed Apr. 17, 2009 Notice of Allowance dated Dec. 13, 2016.

U.S. Appl. No. 13/469,932, filed May 11, 2012 Notice of Allowance dated Jan. 31, 2017.

U.S. Appl. No. 14/040,205, filed Sep. 27, 2013 Advisory Action dated Dec. 15, 2016.

U.S. Appl. No. 14/054,700, filed Oct. 15, 2013 Advisory Action dated Dec. 15, 2016.

U.S. Appl. No. 14/201,300, filed Mar. 7, 2014 Advisory Action dated Mar. 2, 2017.

U.S. Appl. No. 14/201,300, filed Mar. 7, 2014 Final Office Action dated Dec. 19, 2016.

U.S. Appl. No. 14/615,932, filed Feb. 6, 2015 Non-Final Office Action dated Dec. 29, 2016.

U.S. Appl. No. 15/160,958, filed May 20, 2016 Non-Final Office Action dated Dec. 15, 2016.

CN 200880012117.4 filed Apr. 16, 2008 Fourth Office Action dated Sep. 4, 2011.

CN 201180037065.8 filed Jan. 28, 2013 Fourth Office Action dated May 5, 2016.

JP 2010-504220 filed Sep. 3, 2009 Office Action dated Apr. 1, 2014.

JP 2010-504220 filed Sep. 3, 2009 Office Action dated Apr. 18, 2013.

JP 2013-512046 filed Nov. 26, 2012 Office Action dated May 16, 2016.

JP 2014-519081 filed Dec. 27, 2013 First Office Action dated Apr. 26, 2016.

JP 2013-530322 filed Mar. 18, 2013, Office Action dated May 2, 2016.

KR 10-2012-7000866 filed Jan. 11, 2012 First Office Action dated Jun. 16, 2016.

RU 2013158008 filed Dec. 26, 2013 First Office Action dated May 27, 2016.

U.S. Appl. No. 12/369,625, filed Feb. 11, 2009 Notice of Panel Decision dated Aug. 1, 2012.

U.S. Appl. No. 12/893,916, filed Sep. 29, 2010 Advisory Action dated Jun. 2, 2016.

U.S. Appl. No. 13/240,171, filed Sep. 22, 2011 Advisory Action dated Jul. 22, 2016.

U.S. Appl. No. 13/336,919, filed Dec. 23, 2011 Notice of Allowance dated Jul. 26, 2016.

(56)

## References Cited

## OTHER PUBLICATIONS

U.S. Appl. No. 13/337,987, filed Dec. 27, 2011 Examiner's Answer dated Jul. 2, 2014.

U.S. Appl. No. 13/337,987, filed Dec. 27, 2011 Final Office Action dated Sep. 19, 2013.

U.S. Appl. No. 13/469,932, filed May 11, 2012 Advisory Action dated Jun. 27, 2016.

U.S. Appl. No. 13/858,782, filed Apr. 8, 2013 Notice of Allowance dated Oct. 9, 2014.

U.S. Appl. No. 13/890,158, filed May 8, 2013 Advisory Action dated Jul. 26, 2016.

U.S. Appl. No. 14/141,046, filed Dec. 26, 2013 Advisory Action dated Aug. 4, 2016.

U.S. Appl. No. 14/141,046, filed Dec. 26, 2013 Final Office Action dated May 11, 2016.

U.S. Appl. No. 14/201,300, filed Mar. 7, 2014 Advisory Action dated Jul. 18, 2016.

U.S. Appl. No. 14/309,511, filed Jun. 19, 2014 Notice of Allowance, dated Jul. 26, 2016.

U.S. Appl. No. 14/317,501, filed Jun. 27, 2014 Examiner's Answer dated Jun. 30, 2016.

U.S. Appl. No. 14/498,887, filed Sep. 26, 2014 Final Office Action dated Jun. 15, 2016.

U.S. Appl. No. 14/548,151, filed Nov. 19, 2014 Advisory Action dated Jul. 22, 2016.

AU 2012278809 filed Nov. 12, 2013 Notice of Acceptance dated Sep. 13, 2016.

CA 2,721,715 filed Apr. 17, 2009 Examiner's Report dated Oct. 25, 2016.

CN 200980144663.8 filed May 9, 2011 Notice of Reexamination dated Aug. 5, 2016.

CN 201180037065.8 filed Jan. 28, 2013 Notice of Grant dated Aug. 30, 2016.

CN 201410009216.4 filed Jan. 8, 2014 Office Action dated Jun. 15, 2016.

EP 13840356.3 filed Apr. 27, 2015 Partial European Search Report dated Oct. 19, 2016.

EP 13846380.7 filed May 15, 2015 Partial European Search Report dated Sep. 30, 2016.

EP 14761249.3 Filed Sep. 3, 2015 Extended European Search Report dated Sep. 19, 2016.

KR 10-2012-7000866 filed Jan. 11, 2012 Second Office Action dated Nov. 3, 2016.

PCT/US2016/039356 filed Jun. 24, 2016 International Search Report and Written Opinion dated Sep. 16, 2016.

U.S. Appl. No. 12/426,175, filed Apr. 17, 2009 Decision on Appeal dated Nov. 7, 2016.

U.S. Appl. No. 12/893,916, filed Sep. 29, 2010 Non-Final Office Action dated Aug. 31, 2016.

U.S. Appl. No. 13/118,033, filed May 27, 2011 Notice of Allowance dated Sep. 2, 2016.

U.S. Appl. No. 14/040,205, filed Sep. 27, 2013 Final Office Action dated Oct. 19, 2016.

U.S. Appl. No. 14/054,700, filed Oct. 15, 2013 Final Office Action dated Oct. 19, 2016.

U.S. Appl. No. 14/201,300, filed Mar. 7, 2014 Non-Final Office Action dated Aug. 24, 2016.

U.S. Appl. No. 14/498,887, filed Sep. 26, 2014 Advisory Action dated Aug. 22, 2016.

U.S. Appl. No. 14/548,151, filed Nov. 19, 2014 Non-Final Office Action dated Sep. 28, 2016.

U.S. Appl. No. 14/846,496, filed Sep. 4, 2015 Non-Final Office Action dated Nov. 25, 2016.

CN 201180037065.8 filed Jan. 28, 2013 Third Office Action dated Nov. 24, 2015.

CN 201180040151.4 filed Feb. 19, 2013 Office Action dated Dec. 10, 2015.

CN 201180052587.5 filed Apr. 28, 2013 Office Action dated Feb. 24, 2016.

CN 201280033189.3 filed Jan. 3, 2014 First Office Action dated Apr. 3, 2014.

CN 201280033189.3 filed Jan. 3, 2014 Second Office Action dated Sep. 14, 2015.

CN 201410009216.4 filed Jan. 8, 2014 Second Office Action dated Sep. 25, 2015.

EP 09743249.6 filed Oct. 18, 2010 Extended European Search Report dated Jan. 13, 2016.

EP 11740309.7 filed Aug. 23, 2012 Extended European Search Report dated Aug. 3, 2015.

EP 15179061.5 filed Jul. 30, 2015 Extended European Search Report dated Jan. 14, 2016.

JP 2013-512046 filed Nov. 26, 2012 Office Action dated Dec. 8, 2015.

JP2013-530322 filed Mar. 18, 2013, First Office Action dated Jul. 31, 2015.

MX/a/2013/001317 filed Jan. 31, 2013 First Office Action dated Nov. 26, 2015.

U.S. Appl. No. 12/854,083, filed Aug. 10, 2010 Non-Final Office Action dated Feb. 1, 2016.

U.S. Appl. No. 12/893,916, filed Sep. 29, 2010 Final Office Action dated Mar. 25, 2016.

U.S. Appl. No. 13/118,033, filed May 27, 2011 Final Office Action dated Apr. 1, 2016.

U.S. Appl. No. 13/118,138, filed May 27, 2011 Final Office Action dated Apr. 1, 2016.

U.S. Appl. No. 13/240,171, filed Sep. 22, 2011 Final Office Action dated May 6, 2016.

U.S. Appl. No. 13/240,171, filed Sep. 22, 2011 Non-Final Office Action dated Dec. 1, 2015.

U.S. Appl. No. 13/469,932, filed May 11, 2012 Final Office Action dated Apr. 7, 2016.

U.S. Appl. No. 13/665,420, filed Oct. 31, 2012 Final Office Action dated Apr. 8, 2016.

U.S. Appl. No. 14/040,205, filed Sep. 27, 2013 Non-Final Office Action dated Mar. 10, 2016.

U.S. Appl. No. 14/201,300, filed Mar. 7, 2014 Final Office Action dated May 5, 2016.

U.S. Appl. No. 14/201,300, filed Mar. 7, 2014 Non-Final Office Action dated Jan. 6, 2016.

U.S. Appl. No. 14/449,061, filed Jul. 31, 2014 Notice of Allowance dated Apr. 13, 2016.

U.S. Appl. No. 14/498,887, filed Sep. 26, 2014 Non-Final Office Action dated Feb. 19, 2016.

CA 2800810 filed Nov. 26, 2012 Office Action dated Mar. 30, 2017.

CN 201380065663.5 filed Jun. 15, 2015 Office Action dated Mar. 15, 2017.

CO 15110530 filed May 14, 2015 Office Action dated May 8, 2017.

EP 13840356.3 filed Apr. 27, 2015 Extended European Search Report dated Mar. 22, 2017.

JP 2013-530322 filed Mar. 18, 2013, Office Action dated Mar. 2, 2017.

U.S. Appl. No. 13/665,420, filed Oct. 31, 2012 Non-Final Office Action dated Mar. 15, 2017.

U.S. Appl. No. 13/890,158, filed May 8, 2013 Non-Final Office Action dated Apr. 7, 2017.

U.S. Appl. No. 14/141,046, filed Dec. 26, 2013 Non-Final Office Action dated Apr. 7, 2017.

U.S. Appl. No. 14/201,300, filed Mar. 7, 2014 Non-Final Office Action dated Mar. 30, 2017.

U.S. Appl. No. 14/548,151, filed Nov. 19, 2014 Final Office Action dated Apr. 19, 2017.

U.S. Appl. No. 15/160,958, filed May 20, 2016 Final Office Action dated Apr. 21, 2017.

U.S. Appl. No. 15/284,355, filed Oct. 3, 2016 Non-Final Office Action dated Apr. 24, 2017.

CN 201380051172.5 filed Mar. 30, 2015 Office Action dated May 2, 2017.

EP 11850625.2 filed Jul. 22, 2013 Extended European Search Report dated Jun. 21, 2017.

EP 14197137.4 filed Dec. 10, 2014 Extended European Search Report dated Nov. 4, 2015.

(56)

**References Cited**

OTHER PUBLICATIONS

EP 14197137.4 filed Dec. 10, 2014, Partial European Search Report dated May 29, 2015.

EP 15746326.6 filed Jul. 1, 2016 Extended European Search Report dated Jun. 9, 2017.

EP 17157118.5 filed Feb. 21, 2017 Extended European Search Report dated Jun. 8, 2017.

JP 2015-534770 filed Mar. 26, 2015 Office Action dated Jun. 12, 2017.

U.S. Appl. No. 14/054,700, filed Oct. 15, 2013 Examiner's Answer dated Jul. 3, 2017.

U.S. Appl. No. 14/201,300, filed Mar. 7, 2014 Final Office Action dated Jul. 10, 2017.

U.S. Appl. No. 15/160,958, filed May 20, 2016 Advisory Action dated Jul. 10, 2017.

U.S. Appl. No. 15/585,051, filed May 2, 2017 Non-Final Office Action dated Jul. 14, 2017.

\* cited by examiner

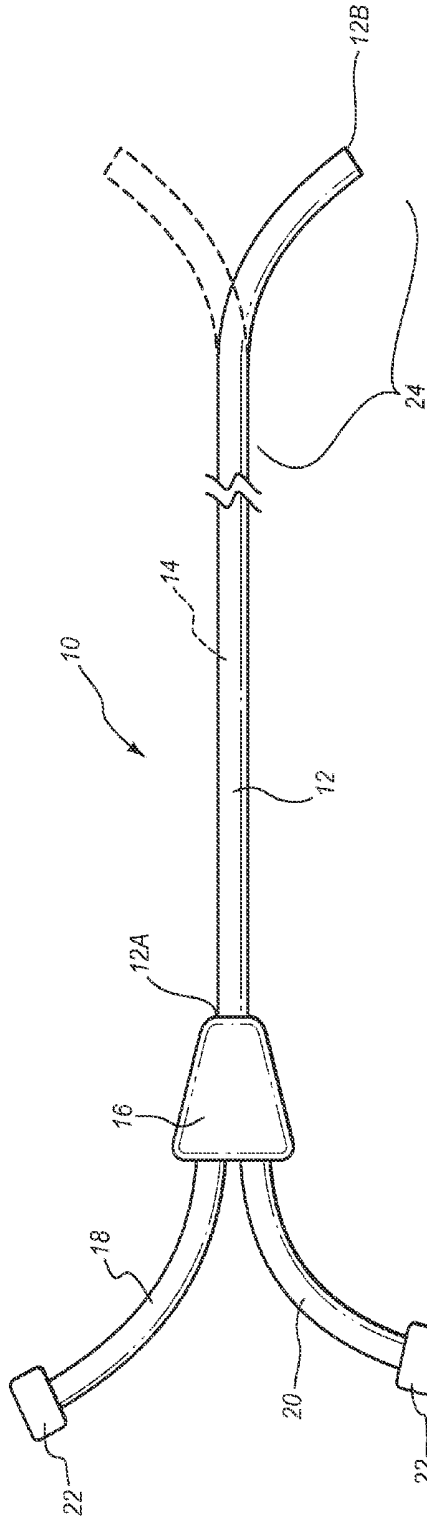

FIG. 1

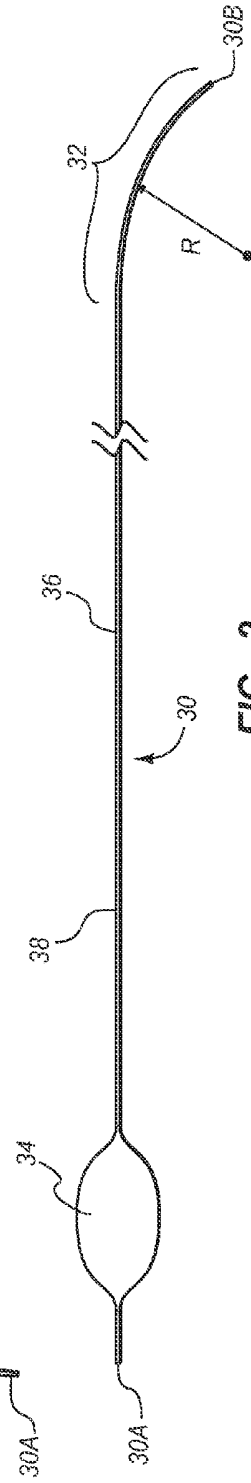

FIG. 2

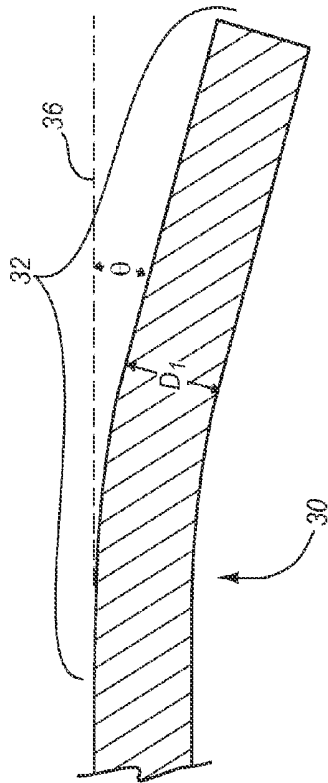

FIG. 3C

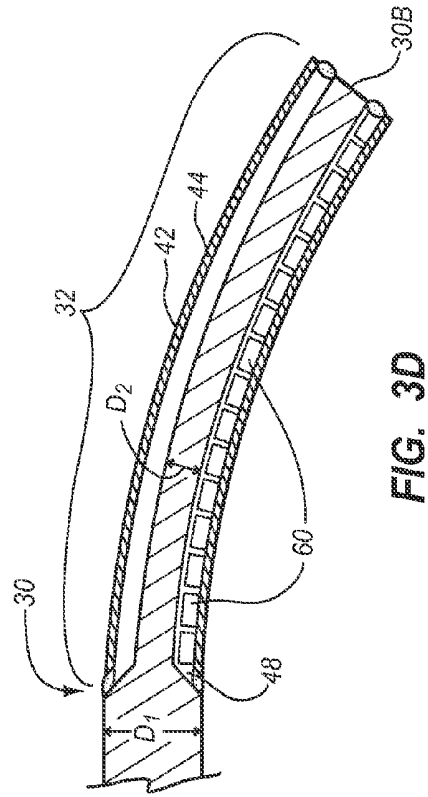

FIG. 3D

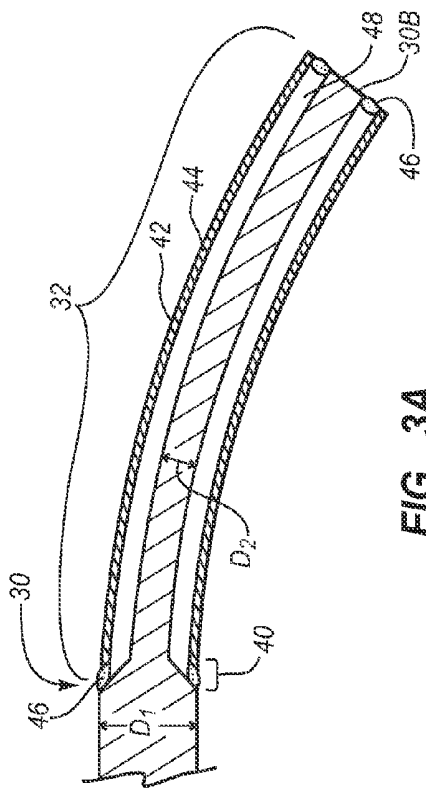

FIG. 3A

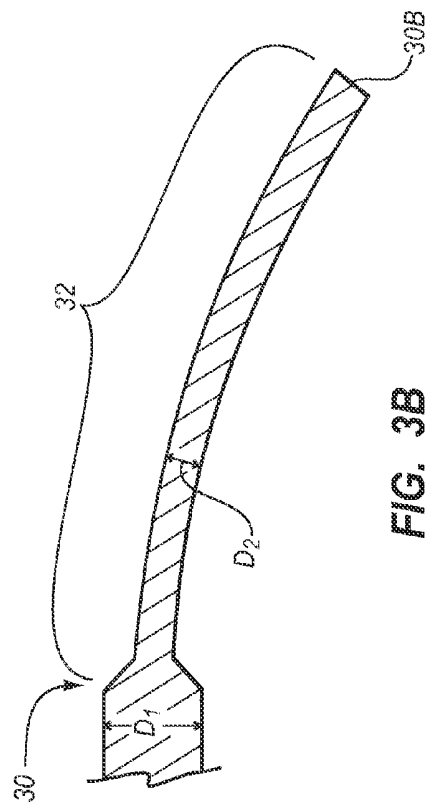

FIG. 3B

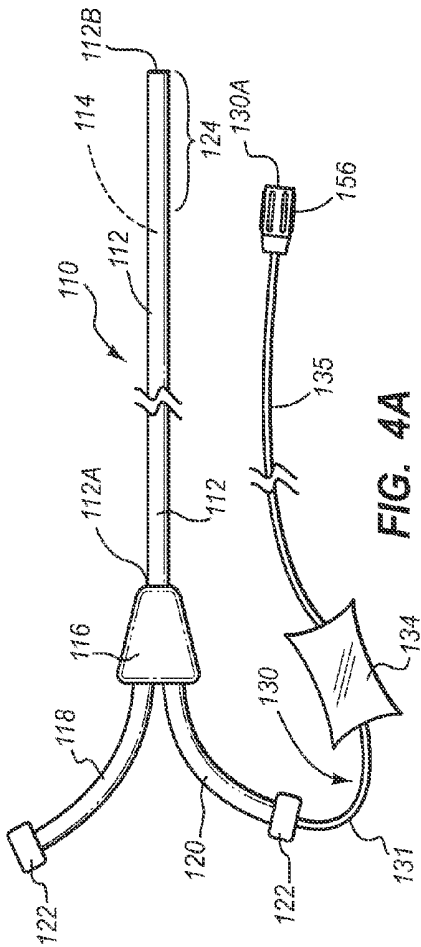

FIG. 4A

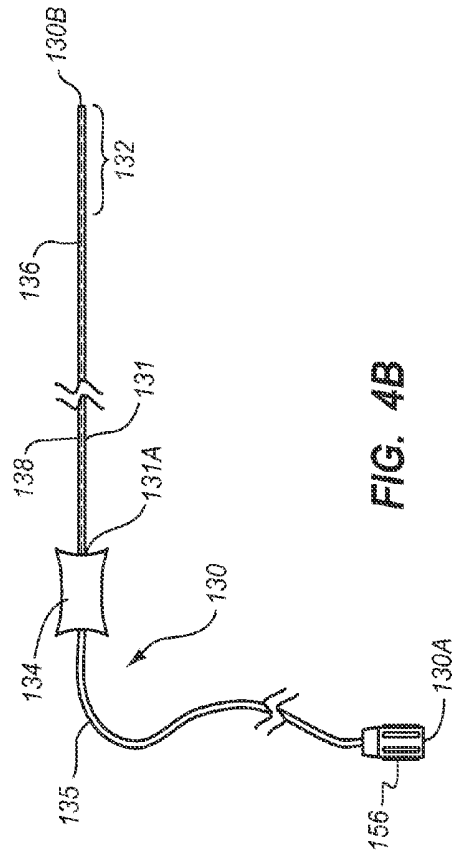

FIG. 4B

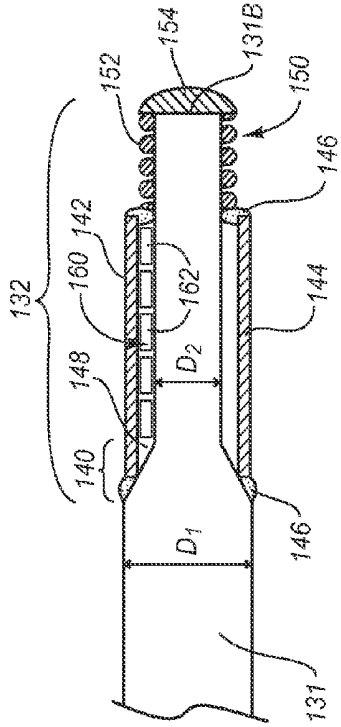

FIG. 5

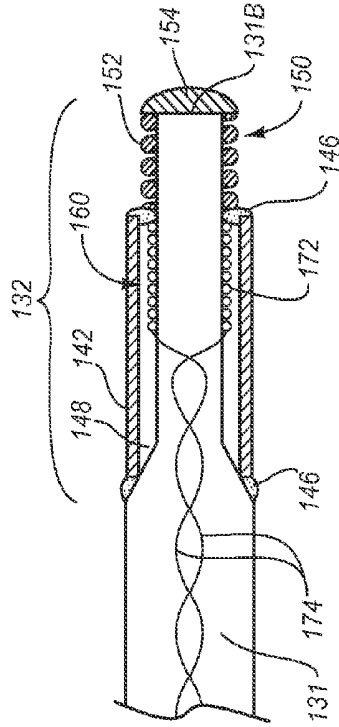

FIG. 7

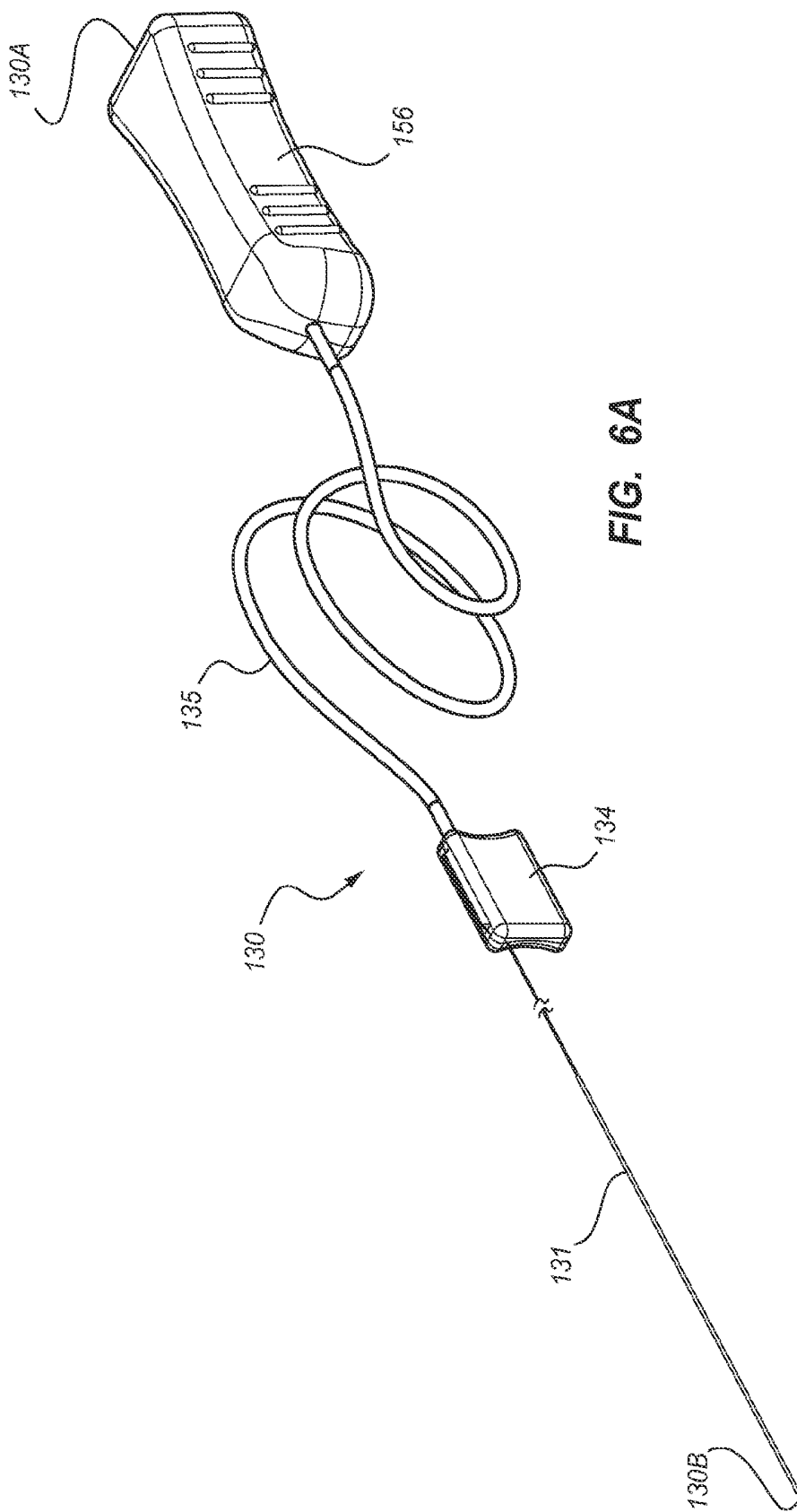
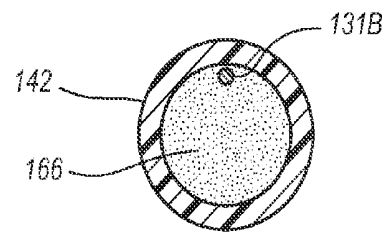
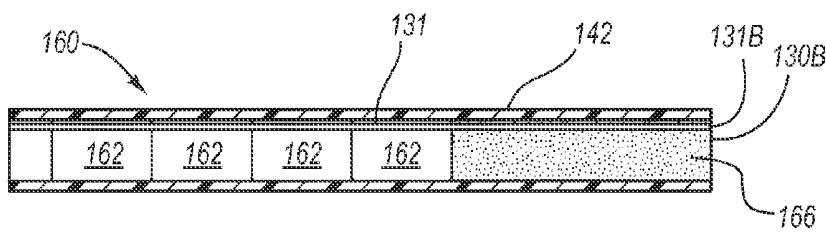
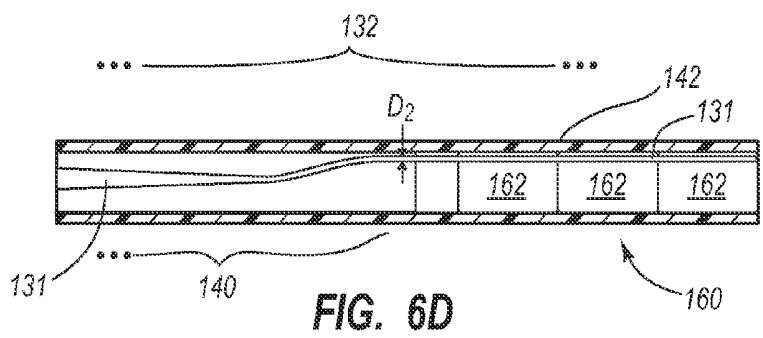
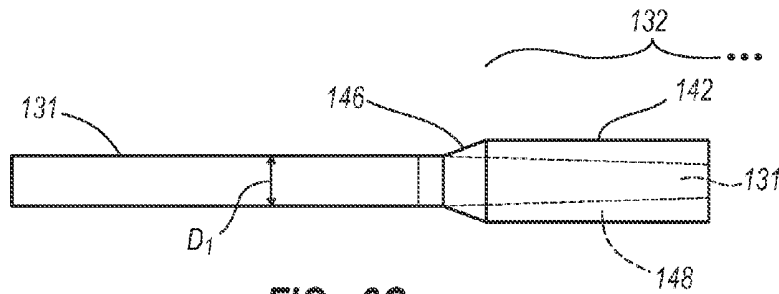
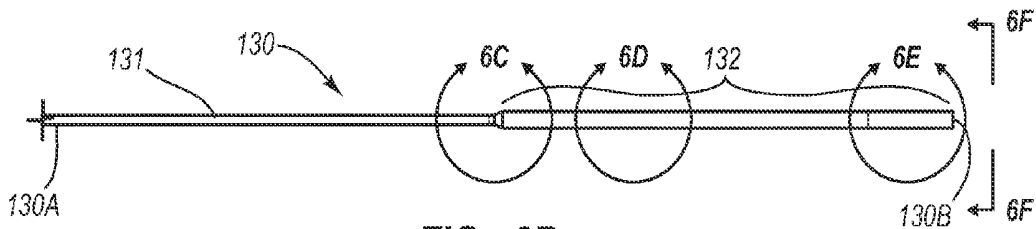

FIG. 6A



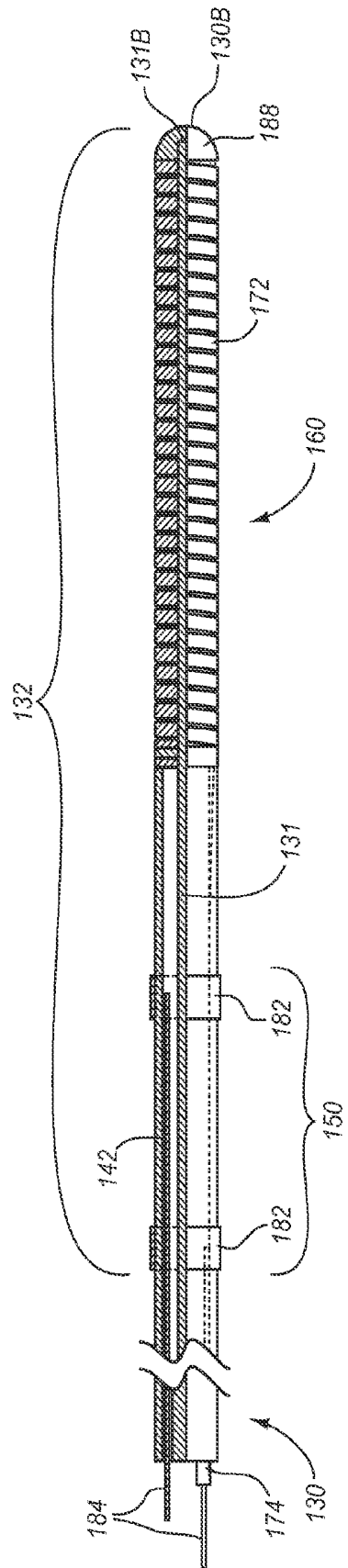

FIG. 8

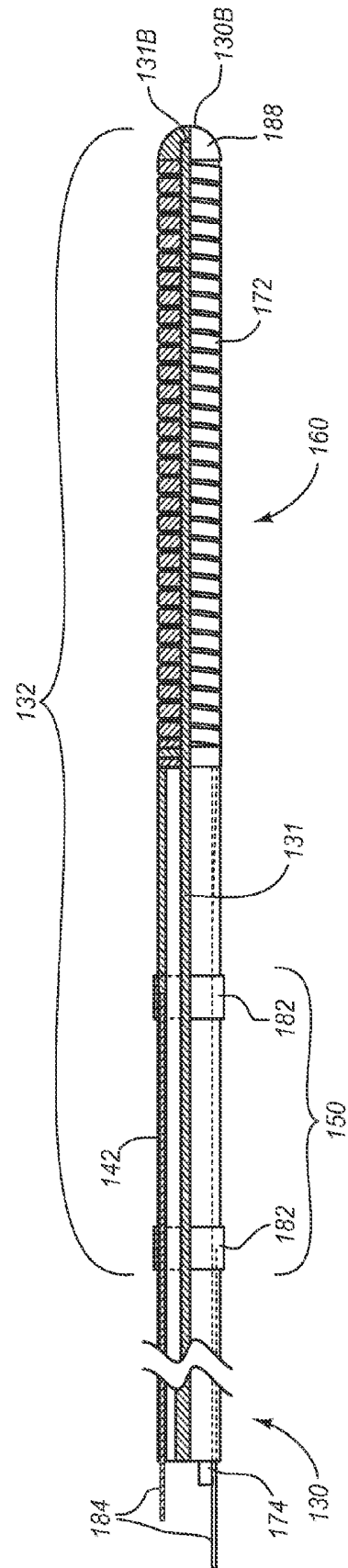

FIG. 9

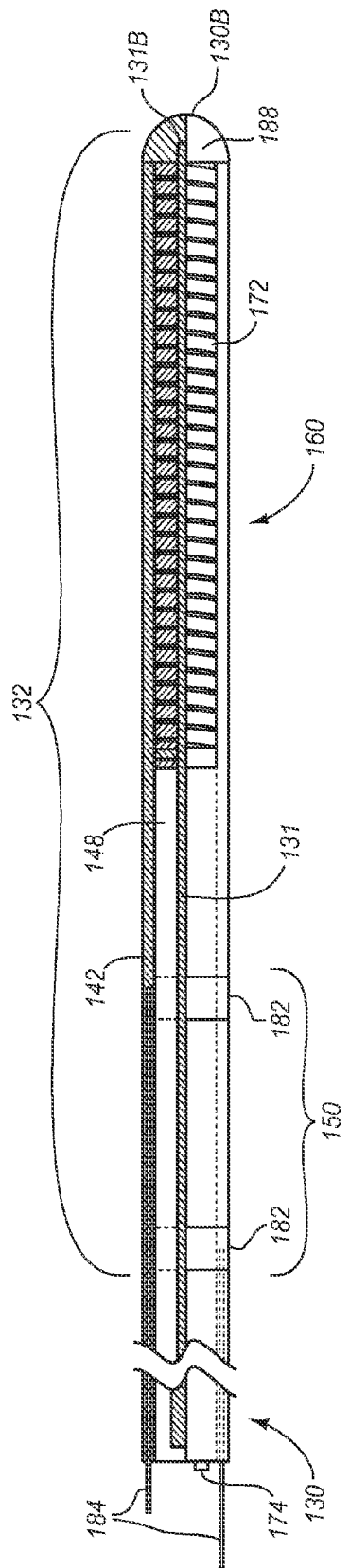

FIG. 10

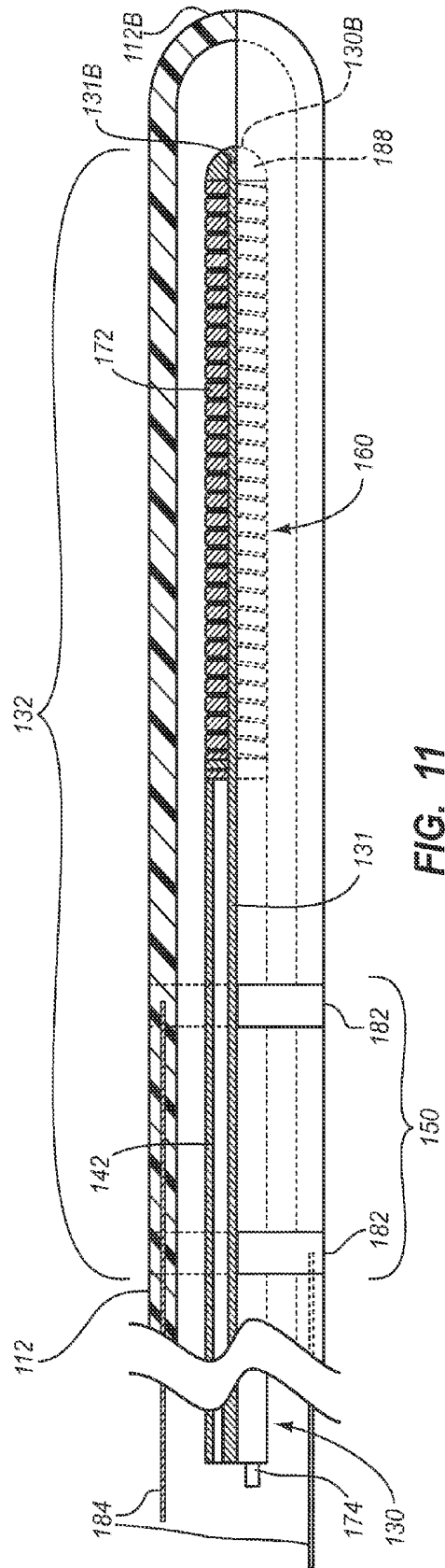

FIG. 11

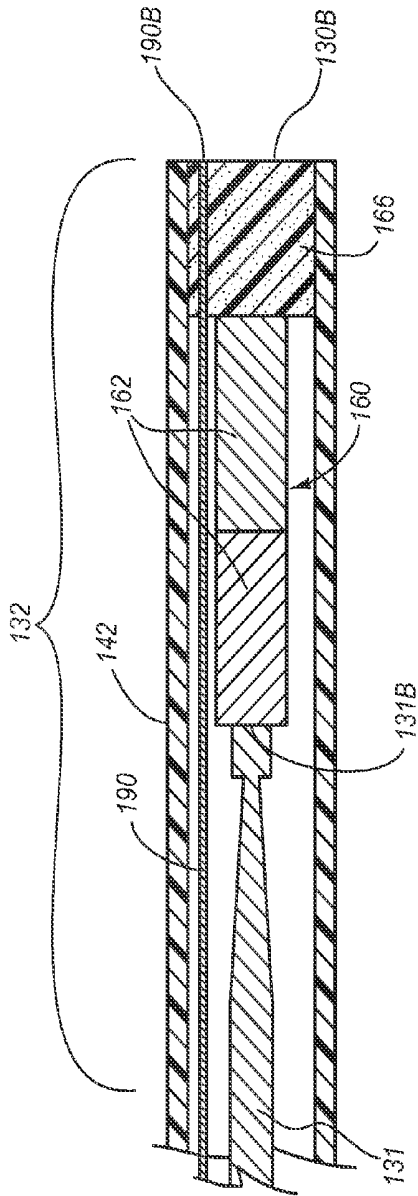

FIG. 12

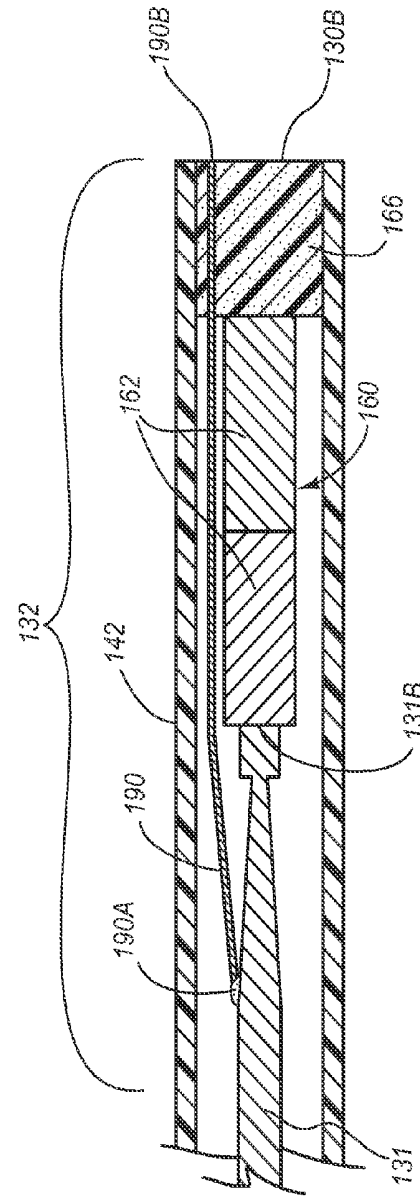

FIG. 13

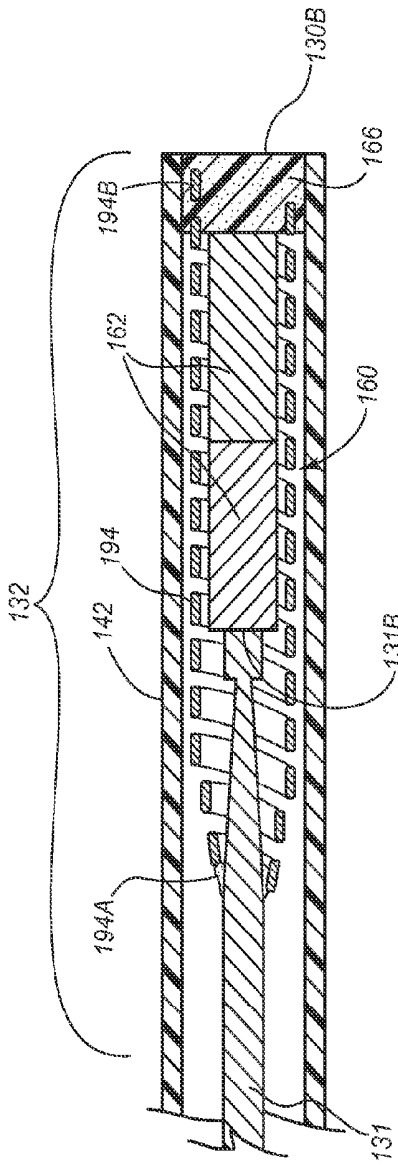

FIG. 14

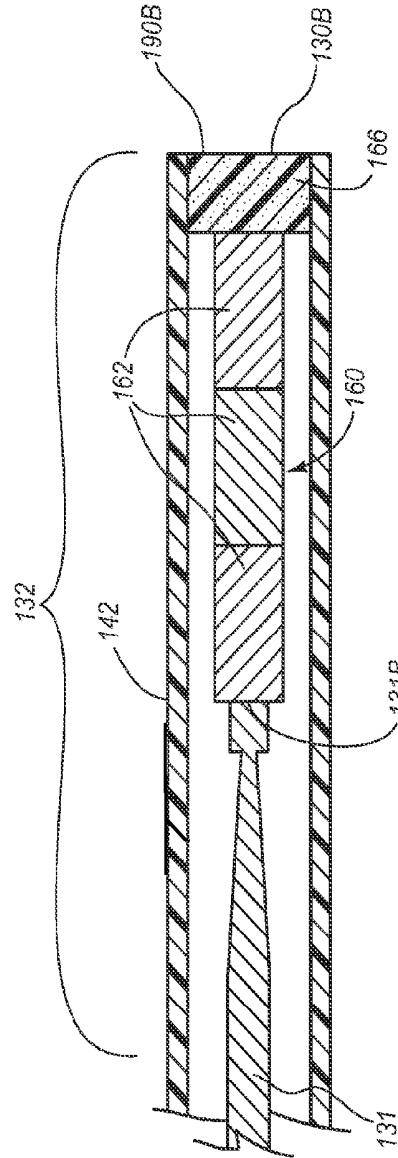

FIG. 15

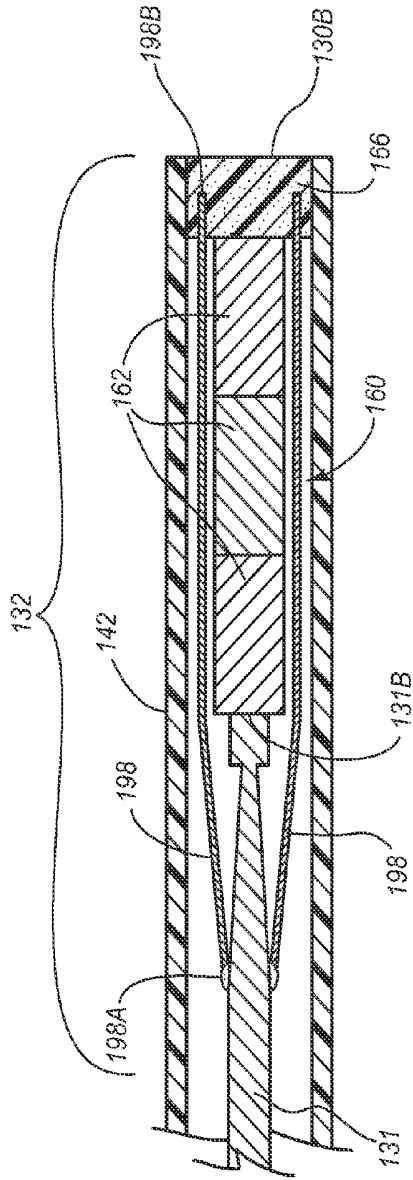

FIG. 16

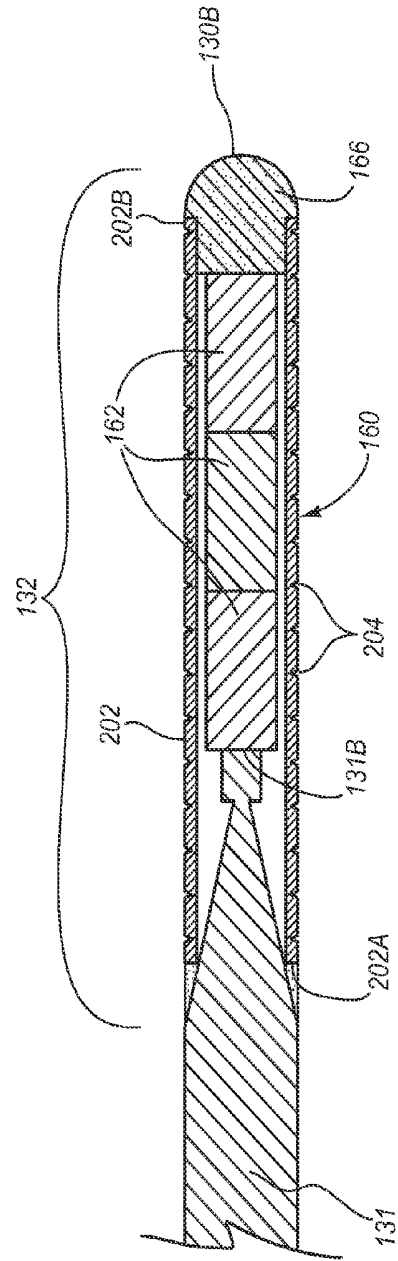

FIG. 17

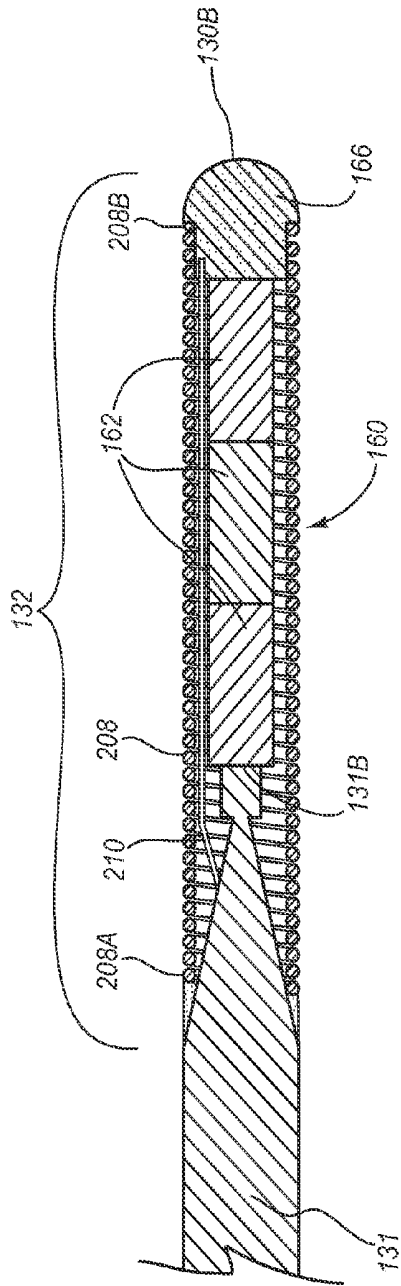

FIG. 18

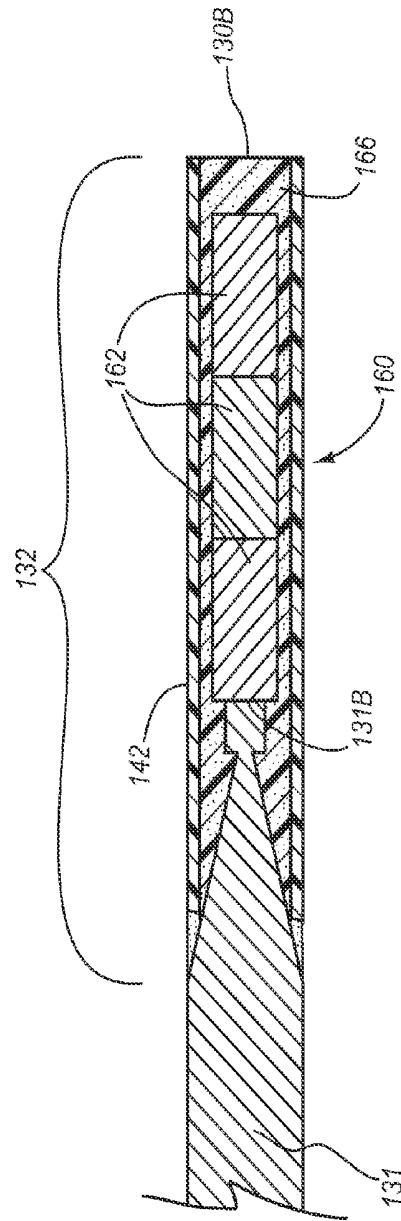

FIG. 19

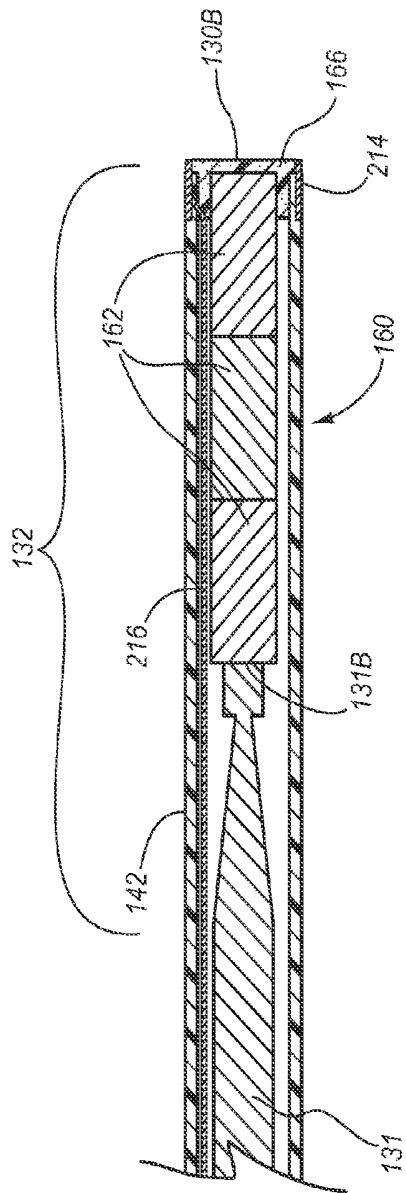

FIG. 20

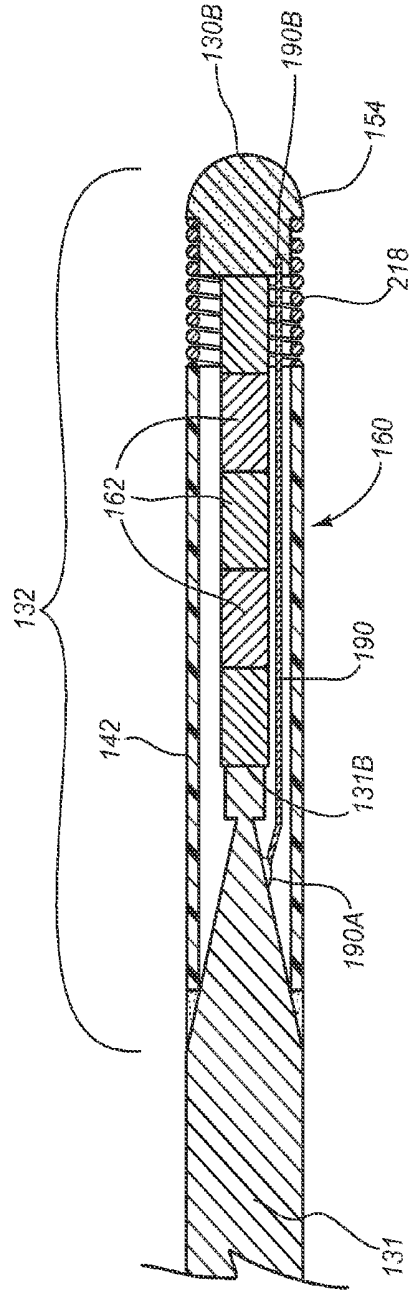

FIG. 21

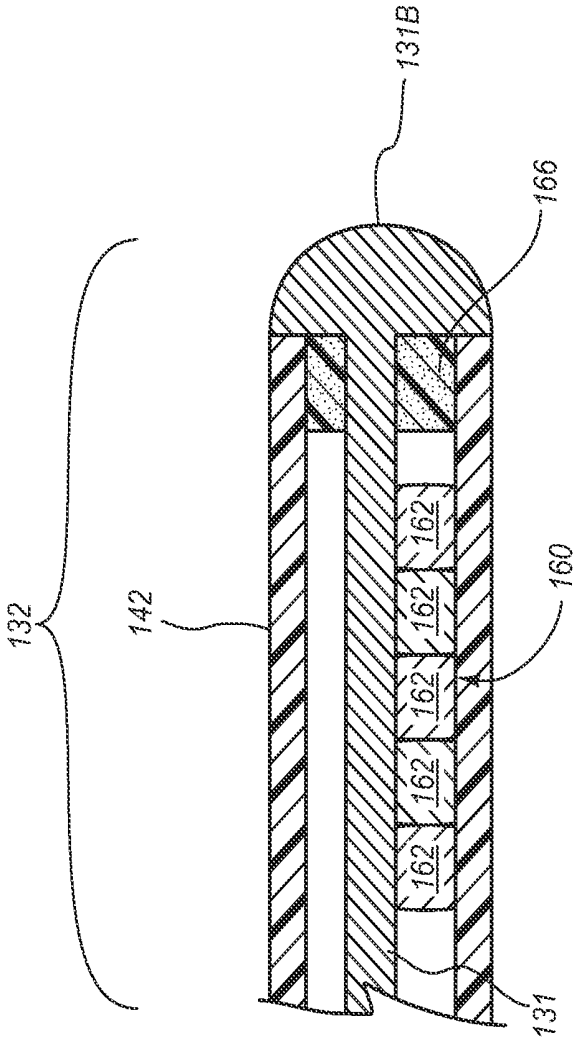

FIG. 22

## CATHETER ASSEMBLY INCLUDING ECG SENSOR AND MAGNETIC ASSEMBLIES

### CROSS-REFERENCE TO RELATED APPLICATIONS

This application claims the benefit of U.S. Provisional Patent Application No. 61/091,233, filed Aug. 22, 2008, and entitled "Catheter Including Preloaded Steerable Stylet;" and U.S. Provisional Patent Application No. 61/095,451, filed Sep. 9, 2008, and entitled "Catheter Assembly Including ECG and Magnetic-Based Sensor Stylet," each of which is incorporated herein by reference in its entirety.

### BRIEF SUMMARY

Briefly summarized, embodiments of the present invention are directed to a stylet for use in guiding a distal tip of a catheter to a predetermined location within the body of a patient. In one embodiment the stylet is configured for use within a lumen of the catheter and comprises a core wire, an ECG sensor, and a magnetic assembly. The ECG sensor senses an ECG signal of a patient when the stylet is disposed within the lumen of the catheter and the catheter is disposed within the body of the patient. The magnetic assembly includes at least one element capable of producing a magnetic or electromagnetic field for detection by a sensor external to the patient.

In another embodiment, the stylet includes a pre-shaped distal segment that is deflected with respect to a more proximal portion of the stylet, which in turn causes a distal segment of the catheter to be deflected when the stylet is received within the catheter lumen.

These and other features of embodiments of the present invention will become more fully apparent from the following description and appended claims, or may be learned by the practice of embodiments of the invention as set forth hereinafter.

### BRIEF DESCRIPTION OF THE DRAWINGS

A more particular description of embodiments of the invention will be rendered by reference to specific embodiments thereof that are illustrated in the appended drawings. It is appreciated that these drawings depict only typical embodiments of the invention and are therefore not to be considered limiting of its scope. The embodiments will be described and explained with additional specificity and detail through the use of the accompanying drawings in which:

FIG. 1 is a top view of a catheter assembly including a shaped, torqueable stylet according to one example embodiment of the present invention;

FIG. 2 is a top view of the stylet of FIG. 1;

FIG. 3A is a top view of a shaped distal portion of the stylet of FIG. 2, according to one possible configuration;

FIG. 3B is a top view of the shaped distal portion of the stylet of FIG. 2, according to another possible configuration;

FIG. 3C is a top view of the shaped distal portion of the stylet of FIG. 2, according to yet another possible configuration;

FIG. 3D is a top view of the shaped distal portion of the stylet of FIG. 2, according to still another possible configuration;

FIG. 4A is a top view of a catheter assembly including a stylet loaded therein and configured in accordance with one embodiment of the present invention;

FIG. 4B is a top view of the stylet of FIG. 4A, according to one embodiment;

FIG. 5 is a cross sectional view of a distal segment of the stylet of FIG. 4B, according to one embodiment;

FIGS. 6A-6F are various views of a stylet in accordance with another embodiment;

FIG. 7 is a cross sectional view of a distal segment of the stylet of FIG. 4B, according to another embodiment;

FIG. 8 is a partial cross sectional view of a distal segment of a stylet configured in accordance with one example embodiment;

FIG. 9 is a partial cross sectional view of a distal segment of a stylet configured in accordance with another embodiment;

FIG. 10 is a partial cross sectional view of a distal segment of a stylet configured in accordance with yet another embodiment;

FIG. 11 is a partial cross sectional view of a distal segment of a stylet and catheter configured in accordance with one embodiment;

FIG. 12 is a cross sectional view of a distal segment of a stylet configured in accordance with one embodiment;

FIG. 13 is a cross sectional view of a distal segment of a stylet configured in accordance with one embodiment;

FIG. 14 is a cross sectional view of a distal segment of a stylet configured in accordance with one embodiment;

FIG. 15 is a cross sectional view of a distal segment of a stylet configured in accordance with one embodiment;

FIG. 16 is a cross sectional view of a distal segment of a stylet configured in accordance with one embodiment;

FIG. 17 is a cross sectional view of a distal segment of a stylet configured in accordance with one embodiment;

FIG. 18 is a cross sectional view of a distal segment of a stylet configured in accordance with one embodiment;

FIG. 19 is a cross sectional view of a distal segment of a stylet configured in accordance with one embodiment;

FIG. 20 is a cross sectional view of a distal segment of a stylet configured in accordance with one embodiment;

FIG. 21 is a cross sectional view of a distal segment of a stylet configured in accordance with one embodiment; and

FIG. 22 is a cross sectional view of a distal segment of a stylet configured in accordance with one embodiment.

### DETAILED DESCRIPTION OF SELECTED EMBODIMENTS

Reference will now be made to figures wherein like structures will be provided with like reference designations. It is understood that the drawings are diagrammatic and schematic representations of exemplary embodiments of the invention, and are not limiting of the present disclosure nor are they necessarily drawn to scale.

FIGS. 1-22 depict various features of embodiments of the present invention, which is generally directed, in one embodiment, to a catheter assembly including a pre-loaded stylet therein. In one embodiment, the catheter assembly includes a distal portion shaped in a bent configuration. The bent configuration of the catheter distal portion is caused by the pre-loaded stylet, which includes a pre-shaped distal segment deflected in a bent configuration. Thus, the pre-shaped distal segment of the stylet urges the distal portion of the catheter into a similar bent configuration.

Further, the pre-loaded stylet is configured to be torqueable, thus enabling the stylet to be rotatable within the catheter lumen. A hydrophilic coating applied to an outer surface of the stylet facilitates such stylet rotation. Rotation of the shaped stylet enables the pre-shaped distal segment to

be changed in orientation. This in turn causes a change in orientation of the distal portion of the catheter to occur. Such “steerability” enables the catheter to be more easily guided through the vasculature of a patient during placement of the catheter.

In another embodiment, a stylet for use in guiding a distal tip of a catheter in which the stylet is disposed to a predetermined location within the vasculature of a patient is disclosed. The stylet includes a magnetic assembly proximate its distal tip for use with an external magnetic sensor to provide information relating to general positioning/orientation of the catheter tip during navigation through the patient vasculature. The stylet further includes an ECG sensor proximate its distal tip for use with an external ECG monitoring system to determine proximity of the catheter distal tip relative to an electrical impulse-emitting node of the patient’s heart, such as the SA node in one example. Such electrical impulses are also referred to herein as “ECG signals.” Inclusion of the magnetic and ECG sensors with the stylet enables the catheter to be guided with a relatively high level of precision to a predetermined location proximate the patient’s heart.

For clarity it is to be understood that the word “proximal” refers to a direction relatively closer to a clinician using the device to be described herein, while the word “distal” refers to a direction relatively further from the clinician. For example, the end of a catheter placed within the body of a patient is considered a distal end of the catheter, while the catheter end remaining outside the body is a proximal end of the catheter. Further, the words “including,” “has,” and “having,” as used herein, including the claims, shall have the same meaning as the word “comprising.”

Reference is first made to FIG. 1, which depicts a catheter assembly, generally designated at 10 and configured in accordance with one example embodiment of the present invention. As shown, the catheter assembly 10 includes a catheter 12 having a proximal end 12A, a distal end 12B, and defining at least one lumen 14 extending therebetween. In the present embodiment, the catheter is a PICC, though in other embodiments other types of catheters, having a variety of size, lumen, and prescribed use configurations can benefit from the principles described herein. Further, though shown here with an open distal end, the catheter in other embodiments can have a closed distal end. As such, the present discussion is presented by way of example and should therefore not be construed as being limiting of the present invention in any way. Note that the catheter 12 can be formed from one or more of a variety of materials, including polyurethane, polyvinyl chloride, and/or silicone.

A bifurcation, or hub 16, can be included at the catheter proximal end 12A. The hub 16 permits fluid communication between extension tubing 18 and 20 and the lumen(s) 14 of the catheter 12. Each extension tubing component 18 and 20 includes on a proximal end a connector 22 for enabling the catheter assembly 10 to be operably connected to one or more of a variety of medical devices, including syringes, pumps, infusion sets, etc. Again note that the particular design and configuration of the afore-described components are exemplary only.

The catheter 12 includes a distal portion 24 as part of the catheter that is configured for insertion within the vasculature of a patient. As seen in FIG. 1, the distal portion 24 of the catheter 12 includes a deflected, bent configuration with respect to the more proximal portion of the catheter 12. As will be described further below, this bent configuration is caused by a stylet disposed within the catheter and facilitates

relatively easier navigation and placement of the distal tip of the catheter in a preferred location within the patient vasculature.

Together with FIG. 1, reference is now made to FIG. 2. FIG. 1 further shows a stylet 30 extending from a proximal end of the extension tubing 20 and configured in accordance with one embodiment of the present invention. As shown in FIG. 2 removed from the catheter 12, the stylet 30 includes an elongate core wire that defines a proximal end 30A and a distal end 30B. The stylet 30 is pre-loaded within the lumen 14 of the catheter 12 such that the distal end 30B is substantially flush with the opening at the catheter distal end 12B, and such that the proximal portion of the stylet extends from the proximal end of the catheter or one of the extension tubes 18 and 20. Note that, though considered here as a stylet, in other embodiments a guidewire or other catheter guiding apparatus could include the principles of embodiments of the present disclosure described herein.

As mentioned, the body of the stylet 30 is configured as an elongate core wire and is composed of a memory material such as, in one embodiment, a nickel and titanium-containing alloy commonly known by the acronym “nitinol.” Nitinol possesses characteristics that serve well in the present application, including shape memory and torqueability characteristics, as will be explained. In another embodiment, other suitable materials such as stainless steel could be used for the stylet construction. In yet another embodiment, it is appreciated that the distal segment can be manufactured from a memory material such as nitinol, while the more proximal portion of the stylet core wire is manufactured with stainless steel or other suitable material.

The stylet 30 further includes a distal segment 32 that is pre-shaped to have a bent configuration with respect to the more proximal portion of the stylet. In particular, the stylet distal segment 32 is bent off-axis with respect to a substantially linear longitudinal axis 36 of the stylet core wire in the view depicted in FIG. 2. Manufacture of the stylet 30 from a shape memory material such as nitinol enables the stylet to be configured such that the core wire retains the curved or other bent distal segment shape shown in FIG. 2 during use with the catheter assembly 10. The distal segment 32 is “pre-shaped” in that it is manufactured to possess a bent or offset configuration before its assembly and retains the configuration after insertion within the catheter 12.

The bent configuration of the distal segment 32 in the embodiment illustrated in FIG. 2 defines an arc or curve having a radius R. In other embodiments, however, the distal segment can be bent or offset from the more proximal portion of the stylet in other ways, such as in FIG. 3C, for example, where the distal segment is approximately linearly offset to define an angle  $\theta$  with the longitudinal axis of the proximal portion of the stylet 30. Combinations of linear and curved bend profiles are also possible. These and other possible bent or offset configurations are therefore contemplated as falling within the claims of the present invention.

Reference is now made to FIG. 3A, which depicts further details of the stylet 30, according to one embodiment. As shown, the pre-shaped distal segment 32 includes a distal portion of the core wire having a diameter D2 that is reduced with respect to the diameter D1 of the more proximal portion of the core wire. The stylet core wire transitions from diameter D1 to D2 at a smooth, linear tapered transition region 40, though in other embodiments a stepped taper, convex or concave taper, or no taper need be present.

A tubing sleeve 42 is slid over the reduced diameter stylet core wire along the distal segment 32 and is sized to substantially match the diameter D1 of the proximal portion

of the stylet core wire, though it can be sized differently, if desired. The sleeve 42 is adhered to the core wire near the transition region 40 and at the distal end 30B of the core wire by an adhesive 46, such as a UV, 2-part epoxy, or other suitable adhesive. So secured, an air gap 48 is created between an outer surface of the core wire and an inner surface of the sleeve 42. In other embodiments, the air gap can be enlarged, reduced, or eliminated.

In the present embodiment, the sleeve 42 includes reinforcement 44 to maintain the sleeve in a bent configuration similar to the bent configuration of the stylet distal segment core wire. The reinforcement 44 can be a metal coil or braided mesh or substrate that is integrated into the structure of the sleeve 42 and is capable of bending so as to assume and maintain a bent shape similar to that shown in FIG. 3A. Characteristics of the sleeve 42 that can be adjusted so as to modify its performance include its wall thickness, melt index, and composition. In the present embodiment, the sleeve 42 is composed of polyimide and the reinforcement 44 is coiled stainless steel. Of course, other suitable materials can be employed, either in lieu of or in combination with, these constituents. In other embodiments, the reinforcement can be configured so as to merely strengthen the sleeve and not maintain its bent configuration, or the reinforcement can be removed from all or a portion of the sleeve. In the latter case, a sleeve having no reinforcement can nevertheless be formed so as to have a pre-shaped, bent configuration. In any of the above embodiments, however, the sleeve can be configured to assist the distal segment 32 of the stylet core wire in urging the distal portion of the catheter 12 into a similar bent configuration, as seen in FIG. 1 and as will be explained in further detail below.

As mentioned, the stylet 30 having a pre-shaped distal segment 32, such as that described in connection with FIG. 3A, is pre-loaded in one embodiment into the catheter 12 before insertion such that the distal segment resides within the lumen 14 at the distal portion 24 of the catheter, placing the distal tips of both the stylet and the catheter in substantial alignment with one another. Note that in other embodiments the distal tips of the stylet and catheter can be in a non-aligning configuration, if desired, and that the catheter can include multiple lumens. So positioned, the distal segment 32 of the stylet 30 imparts an urging force on the distal portion 24 of the catheter 12 such that the catheter distal portion assumes a bent configuration similar to that of the stylet distal segment. As such, it is appreciated that while the stylet 30 is loaded within the catheter 12, the distal portion 24 of the catheter takes on the bent configuration of the distal segment 32 of the stylet. Once the stylet 30 is removed, the catheter 12 is free to return to an unbent configuration commensurate with its original shape when manufactured.

The stylet 30 in one embodiment further includes on its outer surface a hydrophilic coating 38 to assist in rotating the stylet within the lumen 14 of the catheter 12 during use. The wettable coating 38 can be activated, for instance, by flushing the catheter lumen 14 with saline or other aqueous solution, thereby facilitating rotation of the stylet within the lumen. In other embodiments, no coating is included on the stylet. In yet other embodiments, the coating can be included on an inner surface of the catheter, or the composition of the catheter and stylet can be chosen such that a net low coefficient of friction exists between the two surfaces.

A handle 34 can be provided near the proximal end 30A of the stylet 30 so as to enable a user to rotate the stylet within the catheter lumen 14. Because the stylet 30 is at least partially composed of nitinol or other suitable material in one embodiment, the stylet is configured to be torqued by

user application of a rotational force thereto via the handle 34. The handle 34 may take one of many shapes and configurations, including that shown in FIGS. 1 and 2, for example. Torqueability of the stylet 30, together with its hydrophilic coating 38, makes possible selective rotation of the stylet within the catheter lumen 14, which in turn enables selective rotation and orientation of the bent distal segment 32. As before mentioned, no coating may be necessary in one embodiment. In addition, the handle 34 is attached to the stylet core wire so as to correspond with the orientation of the bent distal segment 32. Thus one can determine the orientation of the direction of bend of the distal segment 32 when the distal segment is disposed within the vasculature of a patient by observing the orientation of the handle 34. The handle 34 in one embodiment may include a visual guide or key thereon to assist the clinician in ascertaining the orientation of the bent distal segment 32.

As mentioned, the stylet distal segment 32, having a pre-shaped bent configuration, urges the distal portion 24 of the catheter into a similar bent configuration when the stylet 30 is received in the catheter lumen 14 as shown and described. Rotation of the stylet 30 within the catheter lumen 14 in the manner described above therefore causes a corresponding change in the orientation of the bent configuration of the catheter distal portion 24, shown for example in phantom in FIG. 1. Thus, the catheter distal portion 24 and its corresponding distal tip are "steerable" via torqueable rotation of the stylet 30 by a clinician grasping and turning the handle 34. Such steerability is desirable to enable the catheter distal tip to be navigated through the tortuous vasculature of a patient during placement of the catheter 12. Note that the distal segment 32 is sufficiently resilient to prevent trauma or damage to the vasculature during navigation therein.

In greater detail, with the handle 34 being oriented in a direction corresponding to the direction of bend in the stylet distal segment 32, the clinician placing the catheter within the patient vasculature can ascertain the orientation of the bent catheter distal portion 24, which is disposed within the vasculature during placement, by observing the orientation of the handle 34. The handle 34 therefore acts as a key in determining orientation of the bent configuration of the distal segment 32 of the stylet 30/distal portion 24 of the catheter 12. This aspect assists the clinician in placing the catheter 12 in the patient vasculature so as to place the distal tip of the catheter 12 in a predetermined position by advancing the catheter 12 with the pre-loaded stylet 30 therein. Once the catheter 12 has been placed as desired, the stylet 30 can be removed from the catheter lumen 14 and corresponding extension tubing 18/20 and the catheter prepared for use.

Reference is now made to 3B and 3C, which show aspects of other possible stylet distal segment configurations according to embodiments of the present invention. The distal segment 32 shown in FIG. 3B includes a reduced diameter core wire as in FIG. 3A, but includes no sleeve covering the distal core wire segment. The distal segment 32 shown in FIG. 3C also includes no sleeve, but includes a core wire segment having a non-reduced diameter with respect to the proximal core wire portion. Thus, it is seen that various core wire diameters and omissions of the sleeve or other components may be intended while still residing within the scope of embodiments of the present invention.

Reference is now made to FIG. 3D, which shows yet another example of a stylet distal segment according to one embodiment. In particular, the stylet distal segment 32 of FIG. 3D includes a reduced diameter core wire, sleeve 42

having reinforcement **44**, and air gap **48**, as earlier described in connection with FIG. 3A. A plurality of magnets **60** is disposed in a portion of the air gap **48**. The magnets **60** are employed in the distal segment to enable the distal segment **32** of the stylet **30** to be observable by an exterior tip location system configured to detect the magnetic field of the magnets as the stylet tip advances, together with the catheter distal tip, through the patient vasculature. In the present embodiment, the magnets **60** are ferromagnetic of a solid cylindrical shape, but in other embodiments they may vary from this design in not only shape, but composition, number, size, magnetic type, and position in the stylet distal segment. For instance, the magnetic assembly may include a single or multiple electromagnets disposed in the distal segment in a uni-polar or bi-polar design, in one embodiment.

Note that embodiments of the present disclosure may vary from what is explicitly described herein. For instance, differences in sleeve, air gap, and core wire grind may be present in a stylet distal segment so as to alter bend and resiliency characteristics thereof while still falling under the present claims.

FIGS. 4A-11 depict various features of further embodiments of the present disclosure, directed as before to a stylet for use in guiding a distal tip of a catheter in which the stylet is disposed to a predetermined location within the vasculature of a patient. The stylet includes a magnetic assembly proximate its distal tip for use with an external magnetic sensor to provide information regarding general positioning/orientation of the catheter tip during navigation through the patient vasculature. The stylet further includes an ECG sensor proximate its distal tip for use with an external ECG monitoring system to determine proximity of the catheter distal tip relative to an electrical impulse-emitting node of the patient's heart, such as the SA node in one example. Such electrical impulses are also referred to herein as "ECG signals." Inclusion of the magnetic assembly and ECG sensor with the stylet enables the catheter to be guided with a relatively high level of precision to a predetermined location proximate the patient's heart.

Reference is first made to FIG. 4A, which depicts a catheter assembly, generally designated at **110** and configured in accordance with one example embodiment of the present invention. As shown, the catheter assembly **110** includes a catheter **112** having a proximal end **112A**, a distal end **112B**, and defining at least one lumen **114** extending therebetween. In the present embodiment, the catheter is a peripherally-inserted central catheter ("PICC"), though in other embodiments other types of catheters, having a variety of size, lumen, and prescribed use configurations can benefit from the principles described herein. Further, though shown here with an open distal end, the catheter in other embodiments can have a closed distal end. As such, the present discussion is presented by way of example and should therefore not be construed as being limiting of the present invention in any way.

A hub **116** is included at the catheter proximal end **112A**. The hub **116** permits fluid communication between extension tubing **118** and **120** and the lumen(s) **114** of the catheter **112**. Each extension tubing component **118** and **120** includes on a proximal end a connector **122** for enabling the catheter assembly **110** to be operably connected to one or more of a variety of medical devices, including syringes, pumps, infusion sets, etc. Again note that the particular design and configuration of the afore-described components are exemplary only. For instance, in one embodiment, the catheter need not include a hub or extension legs. The composition

of the catheter in this and other embodiments described herein includes a suitable material, such as polyurethane, silicone, etc.

The catheter **112** includes a distal portion **124** configured for insertion within the vasculature of a patient. The catheter **112** is flexible so as to enable it to bend while being advanced through the patient vasculature.

Together with FIG. 4A, reference is now made to FIG. 4B. FIG. 4A further shows a stylet **130** extending from a proximal end of the extension tubing **120** and configured in accordance with one embodiment of the present invention. As shown in FIG. 4B, the stylet **130** as removed from the catheter **112** defines a proximal end **130A** and a distal end **130B** and generally includes a core wire **131**, a handle **134**, and a tether **135**. The stylet **130** is pre-loaded within the lumen **114** of the catheter **112** in one embodiment such that the distal end **130B** is substantially flush with the opening at the catheter distal end **112B**, and such that the proximal portion of the core wire **131**, the handle **134**, and the tether **135** are located proximal to the proximal end of the catheter or one of the extension tubes **118** and **120**. Note that, though described herein as a stylet, in other embodiments a guide-wire or other catheter guiding apparatus could include the principles of the present invention described herein.

The core wire **131** defines an elongate configuration and is composed of a suitable stylet material including stainless steel or a memory material such as nitinol in one embodiment. Though not shown here, manufacture of the core wire **131** from nitinol in one embodiment enables the portion of the core wire corresponding to a distal segment **132** of the stylet **130** to have a pre-shaped bent configuration, as has already been described.

Further, the nitinol construction lends torqueability to the core wire **131**. Thus, the pre-shaped core wire distal segment **132**, together with core wire torqueability, enables the distal segment of the stylet **130** to be manipulated while disposed within the catheter lumen **114** during catheter insertion, which in turn enables the distal portion **124** of the catheter **112** to be navigated through the vasculature during catheter insertion. In the presently illustrated embodiment, no pre-shaping of the stylet distal segment is shown.

Note also that the present stylet can be employed in a catheter placement system that employs one or more of ultrasound, magnetic-based stylet tip tracking, and ECG-based tip navigation/position confirmation technologies to accurately place a catheter in the vasculature of a patient. Details regarding aspects of an example of such a system are given below, and can also be found in U.S. Patent Application Publication No. 2009/0156926, entitled "Integrated System for Intravascular Placement of a Catheter," filed Nov. 25, 2008; and U.S. patent application Ser. No. 12/426, 175, entitled "Systems and Methods for Breaching a Sterile Field for Intravascular Placement of a Catheter," filed Apr. 17, 2009, each which is incorporated herein by reference in its entirety.

A handle **134** is provided at a proximal end **131A** of the stylet **130** so as to enable insertion/removal of the stylet from the catheter lumen **114**. In embodiments where the stylet core wire **131** is torqueable, the handle **134** enables the core wire **131** to be rotated within the catheter lumen **114**, such as when rotation of a pre-shaped distal segment **132** of the stylet **130** is desired to assist in navigating the catheter distal portion **124** through the vasculature of the patient. In this case, the handle **134** is attached to the stylet core wire so as to correspond with the orientation of the bent distal segment **132**. Thus one can determine the orientation of the direction of bend of the distal segment **132** when the distal segment

is disposed within the vasculature of a patient by observing the orientation of the handle **134**. The handle **134** may include a guide or key thereon to assist the clinician in ascertaining the orientation of the bent distal segment **132**.

Rotation, insertion, and/or removal of the stylet **130** via the handle **134** is further facilitated in one embodiment by application of a hydrophilic coating **138** to an outer surface of the core wire **131** and accompanying sleeve to be described further below. The wettable hydrophilic coating **138** can be activated, for instance, by flushing the catheter lumen **114** with saline or other aqueous solution, thereby facilitating rotation of the stylet within the lumen. The handle **134** may take one of many shapes and configurations, including that shown in FIGS. **2**, **4A**, and **6A**, for example. Note also that in an unbent configuration, the core wire **31** of the stylet **130** defines a substantially linear longitudinal axis **136**.

In the present embodiment, the handle **134** attaches to a distal end of the tether **135**. In the present embodiment, the tether **135** is a flexible, shielded cable housing a plurality of electrically conductive wires. The wires are electrically connected to components, to be discussed below, disposed in the distal segment **132** of the stylet **130**, and as such, they provide a conductive pathway from the distal segment through to the proximal end **130A** of the stylet, where an electrical connector **156** is attached. As will be explained, the electrical connector **156** can take one of many forms and is configured for operable connection to an external magnetic and/or ECG sensor device in assisting navigation of the stylet **130** and catheter **112** to a desired location within the patient vasculature. Note that in another embodiment, the stylet can be un-tethered and electrical connectivity with the stylet distal segment components can be achieved by attaching temporary clips at the handle where the electrical wires from such components exit the stylet, for instance.

Reference is now made to FIG. **5**, which depicts further details of the stylet **130**, according to one embodiment. As shown, the distal segment **132** includes a distal portion of the core wire **131** defining a diameter  $D_2$  that is reduced with respect to the diameter  $D_1$  of the more proximal portion of the core wire. The stylet core wire transitions from diameter  $D_1$  to  $D_2$  at a tapered transition region **140**, though in other embodiments no taper need be present. The reduced diameter portion of the core wire lends desired stiffness and tensile properties thereto, though it is appreciated that in other embodiments no reduction in core wire diameter is necessary.

A sleeve **142** is slid over the reduced diameter stylet core wire along the distal segment **132** and is sized to substantially match the diameter  $D_1$  of the proximal portion of the stylet core wire. The sleeve **142** is adhered to the core wire near the transition region **140** and at the distal end **130B** of the core wire by an adhesive **146**, such as a UV, 2-part epoxy, or other suitable adhesive. So secured, an air gap **148** is created between an outer surface of the core wire and an inner surface of the sleeve **142**. In other embodiments, the air gap can be enlarged, reduced, or eliminated.

In the present embodiment, the sleeve **142** includes reinforcement **144** to assist the core wire **131** in providing proper stylet distal end stiffness and, in cases where the distal segment of the stylet is pre-shaped in a bent configuration, to assist in maintaining the core wire in the bent configuration. The reinforcement **144** can be a metal coil or braided mesh or substrate that is integrated into the structure of the sleeve **142** and is capable of manipulation so as to assume and maintain a bent shape, if desired.

Characteristics of the sleeve **142** that can be adjusted so as to modify its performance include its wall thickness, melt index, and composition. In the present embodiment, the sleeve **142** is composed of materials including polyimide and the reinforcement **144** is coiled stainless steel. Of course, other suitable materials can be employed, either in lieu of or in combination with, these constituents. As mentioned, in embodiments of the present invention the reinforcement can be configured so as to merely strengthen the sleeve and not maintain a bent configuration as in FIG. **5**, to maintain a bent configuration as in FIG. **6A**, or the reinforcement can be removed from all or a portion of the sleeve.

The stylet distal segment **132** further includes an ECG sensor or sensor assembly, generally designated at **150**, according to one embodiment. The ECG sensor assembly **150** enables the stylet, preloaded in the lumen **114** of the catheter **112** during patient insertion, to be employed in detecting an intra-atrial ECG signal produced by an SA or other node of the patient's heart, thus assisting in navigating the distal end **112B** of the catheter to a predetermined location within the vasculature proximate the patient's heart. Thus, the ECG sensor assembly **150** serves as an aide in confirming proper placement of the catheter distal end **112B**.

In the embodiment illustrated in FIG. **5**, the ECG sensor assembly **150** includes a distal portion of the core wire **131**, which is electrically conductive, as is the rest of the core wire. A conductive distal coil **152** is disposed about the distal portion of the core wire **131** adjacent the core wire distal tip **131B**. The distal coil **152** is composed of a conductive material, such as stainless steel. A tip weld **154** is included on the core wire distal tip **131B** to bond the distal coil **152** to the core wire distal tip **131B**. The tip weld **154** further provides an atraumatic distal tip configuration for the core wire **131**. In another embodiment, the distal coil **152** is configured so as to define a diameter equal to that of the tubing sleeve **142** and to define a constant diameter along the stylet length. In yet another embodiment, no coil is included.

Before catheter placement, the stylet **130** is preloaded into the lumen **114** of the catheter **112**. Note that in one embodiment the stylet **130** is preloaded within the catheter lumen **114** before use such that the distal segment **132** of the stylet resides within the lumen at the distal portion **124** of the catheter, placing the distal tips of both the stylet and the catheter in substantial alignment with one another. Once the catheter has been introduced into the patient vasculature and is advanced toward the patient's heart, the distal portion of the core wire **131**, being electrically conductive, begins to detect the electrical impulses produced by the SA node or other suitable node of the patient's heart. The distal coil **152** is included about the core wire distal tip **131B** to increase the relative surface area of the core wire distal portion so as to improve reception of the electrical impulses from the SA node. Note that other structures could be provided to provide the same functionality. As such, the ECG sensor assembly **150** serves as a sensor or electrode for detecting the ECG heart signals. The elongate core wire **131** proximal to the core wire distal segment serves as a conductive pathway to convey the electrical impulses produced by the SA node and received by the ECG sensor assembly **150** away from the distal segment **132** of the stylet **130** to the tether **135**.

An electrical wire or other suitable structure in the tether **135** conveys the signals to an ECG sensor module located external to the patient. The tether **135** is operably connected to the ECG sensor module via the electrical connector **156**, or other suitable direct or indirect connective configuration. Monitoring of the ECG signal received by the external sensor module enables a clinician to observe and analyze

changes in the signal as the catheter advances toward the SA node. When the received ECG signal matches a desired profile, the clinician can determine that the catheter distal end **112B** has reached a desired position with respect to the SA node. In one implementation, for example, this desired position lies within the lower one-third ( $\frac{1}{3}^{rd}$ ) portion of the superior vena cava ("SVC"). Once it has been positioned as desired, the catheter **112** may be secured in place and the stylet **130** removed from the catheter lumen **114**.

In the present embodiment of FIG. 5, the distal segment **132** of the stylet **130** further includes a magnetic assembly, generally designated at **160**. The magnetic assembly **160** in the illustrated embodiment includes a plurality of magnets **162** disposed in a portion of the air gap **148**, and as such the magnets are interposed between an outer surface of the core wire **131** and an inner surface of the sleeve **142**. In the present embodiment, the magnets **162** are ferromagnetic of a solid cylindrical shape stacked end-to-end, but in other embodiments they may vary from this design in not only shape, but also composition, number, size, magnetic type, and position in the stylet distal segment. In one particular embodiment, the magnets **162** include neodymium. In other embodiments, other rare-earth or alternative types of magnets or magnetic elements may be employed. In yet other embodiments, an electromagnet or other element capable of producing an electromagnetic field that can be externally detected and monitored may also be used.

The magnets **162** are employed in the stylet distal segment **132**, preloaded within the lumen **114** of the catheter **112** during catheter placement within the patient's vasculature, to enable the position of the distal segment to be observable relative to a magnetic sensor placed in close proximity to the patient's body as part of an exterior tip location system. The tip location system is configured to detect the magnetic field of the magnets **162** as the stylet distal segment **132** advances, together with the catheter distal portion **124**, through the patient vasculature. In this way, a clinician placing the catheter **112** is able to generally determine the location, orientation, and/or advancement of the catheter distal end **112B** within the patient vasculature and detect when catheter malposition is occurring, such as advancement of the catheter along an undesired vein, for instance.

The ECG sensor assembly **150** and magnetic assembly **160** can work in concert in assisting a clinician in placing a catheter within the vasculature. Generally, the magnetic assembly **160** of the stylet **130** assists the clinician in generally navigating the vasculature from initial catheter insertion into the vasculature so as to place the distal end **112B** of the catheter **112** in the general region of the patient's heart. The ECG sensor assembly **150** can then be employed to guide the catheter distal end **112B** to the desired location within the SVC by enabling the clinician to observe changes in the ECG signals produced by the heart as the stylet distal segment and its ECG sensor assembly approach the SA node. Again, once a suitable ECG signal profile is observed, the clinician can determine that the distal end of both the stylet **130** and catheter **112** have arrived at the desired location with respect to the patient's heart.

FIGS. 6A-6F depict the stylet **130** for use in a catheter, such as the catheter **110**, according to one embodiment. As shown, the stylet **130** includes the core wire **131** attached to the handle **134**, with the tether **135** extending proximally from the handle to the electrical connector **156** to enable interconnection with an external ECG sensor module or other suitable device for receiving ECG signals detected by the ECG sensor assembly of the stylet. Though not shown

here, in one embodiment the stylet **130** can include a shaped distal portion as described in connection with FIGS. 1-3D above, such that a distal portion of the catheter is deflected when the stylet is preloaded therein. Note, however, that the discussion to follow applies to stylets including both shaped and non-shaped distal segments.

The stylet **130** shown in FIG. 6B includes the core wire **131** and the distal segment **132**. As shown in FIGS. 6C and 6D, the core wire **131** reduces from a diameter **D1** to a diameter **D2** over a relatively longer transition region **140** than in the previous embodiment. The portion of the core wire **131** corresponding to the transition region **140** is disposed within the sleeve **142**, which attaches to the core wire by the adhesive **146** in the manner shown in FIG. 6C. The air gap **148** is defined between the core wire **131** and the sleeve **142**, as before. The reduced diameter portion of the core wire **131** is deflected from an axially central position in the sleeve to an offset position so as to extend adjacent to a portion of the inner surface of the sleeve **142**, as shown in FIG. 6D. The core wire **131**, in this deflected state, extends to its distal tip **131B**, which corresponds to the distal end **130B** of the stylet **130**.

The deflected position of the core wire **131** provides space for the placement of a plurality of magnetic elements, in this case permanent magnets **162**, along a portion of the length of the distal segment **132**. As illustrated in FIGS. 6B, 6D, and 6E, 20 cylindrical permanent ferromagnetic magnets are placed end to end. Of course, the type, number, shape, and arrangement of the magnets or other magnetic elements could vary from what is depicted and described herein. So configured, the magnets **162** define the magnetic assembly **160** that enables the distal end **130B** of the stylet **130** to be located via an external magnetic sensor module during a procedure to place the catheter in the patient vasculature. For example, in one embodiment, the magnets **162** are employed in the stylet distal segment **132** to enable the position/orientation of the stylet distal end **130B** to be observable relative to an external sensor placed on the patient's chest. As has been mentioned, the external sensor is configured to detect the magnetic field of the magnets **162** as the stylet advances with the catheter through the patient vasculature. In this way, a clinician placing the catheter is able to generally determine the location/orientation of the catheter distal end within the patient vasculature and detect when catheter malposition is occurring, such as advancement of the catheter along an undesired vein, for instance.

An electrically conductive epoxy **166** fills the hollow distal end of the sleeve proximate the stylet distal end **130B**. The epoxy **166** is in electrical communication with the core wire **131** and serves to increase the relative surface area of the core wire **131** at the distal tip **131B** thereof. So configured, the distal portion of the core wire **131** and conductive epoxy **166** define an ECG sensor, with the rest of the core wire defining a conductive pathway with respect to the sensor, thus enabling the location of the stylet distal end **130B** and corresponding catheter distal end **112B** to be positioned near the SA node of the patient's heart using an external ECG sensor module, in the manner as described above. Thus, the magnetic assembly and ECG sensor assembly both provide assistance in navigating a catheter or other indwelling device: the magnetic assembly by providing position/orientation data for the catheter, and the ECG sensor assembly providing proximity data for the catheter with reference to an ECG-signal emitting component, such as the SA node of the patient's heart. These modalities can be used exclusively of one another, successively, or in concert to aid in catheter advancement. Note that in one

embodiment the conductive epoxy 166 can be rounded to provide a rounded stylet distal end 130B. In another embodiment, the conductive epoxy can be replaced by another conductive material such as stainless steel or other suitable metal, etc.

As a brief example of the use of the stylet magnetic and ECG sensor assemblies in assisting in the placement of a catheter, in one embodiment an external sensor is employed by a catheter placement system to detect a magnetic field produced by the magnetic elements of the stylet, which is removably predisposed within the lumen of the catheter during catheter insertion and advancement. The external sensor can be placed on the chest of the patient during catheter insertion to enable the magnetic field of the stylet magnetic elements, disposed in the catheter as described above, to be detected during catheter transit through the patient vasculature. As the magnetic elements of the stylet magnetic assembly are co-terminal with the distal end of the catheter, detection by the external sensor of the magnetic field of the magnetic elements provides information to the clinician and enables the clinician to monitor the position/orientation of the catheter distal end during its transit. Such information can be displayed on a display unit of the catheter placement system for instance. In this way, a clinician placing the catheter is able to generally determine the location/orientation of the catheter distal end within the patient vasculature relative to the TLS sensor 50 and detect when catheter malposition, such as advancement of the catheter along an undesired vein, is occurring.

As described, the stylet further includes an ECG sensor as a sensing component for sensing ECG signals produced by the SA node. In one embodiment the ECG sensor of the stylet works in concert with reference and ground ECG electrodes placed on the skin surface of the patient. ECG signals detected by the stylet ECG sensor can be received by the external sensor referred to above or other suitable component of a catheter placement system, together with signals received by the reference and ground electrodes on the patient's skin. These data can be processed and monitored as the stylet-equipped catheter advances through the patient vasculature. In one embodiment, an electrocardiogram waveform is reproduced on the display using the ECG data. The clinician placing the catheter can monitor the ECG data to determine optimum placement of the distal tip of the catheter, such as proximate the SA node in one embodiment. In one implementation, monitoring of the magnetic assembly data are employed during initial advancement of the catheter through the patient vasculature, while the ECG sensor assembly data are monitored as the catheter approaches a desired final location near the heart, though other combinations of these modalities are also contemplated, including simultaneous use of both modalities in one embodiment.

Note that, in contrast to what is shown in FIGS. 6B-6E, the distal segment of the stylet can be configured such that it defines a constant outside diameter with respect to the more proximal portion thereof.

As has been previously mentioned, other types of magnetic elements, alternative to the permanent magnets described in connection with FIGS. 5 and 6A-6E, may be included with the stylet 130 to form a portion of the magnetic assembly 160 for enabling the position/orientation of the catheter distal end 112B to be generally determined during vasculature navigation. FIG. 7 depicts an example of one such alternative, wherein an electromagnetic ("EM") coil 172 is employed in the magnetic assembly 160 of the stylet distal segment 132. The EM coil 172 is depicted in the

present embodiment as a winding of conductive wire, such as insulated copper wire, wound about a portion of the distal core wire 131 in the air gap 148 within the sleeve 142. Note that the covering of the EM coil 172 by the sleeve 142 provides a secondary level of electrical isolation of electrical energy for the EM coil 172. The coil wire is electrically insulated in the present embodiment so as to prevent its interfering with the ECG signals carried by the core wire 131. Lead wires 174 operably connect with the EM coil 172 and extend proximally along the core wire 131, through the handle 134 and tether 135 to terminate at the connector 156. The lead wires 174 are disposed along the core wire 131 and the rest of the stylet 130 in a free floating, strain relief configuration in the present embodiment so as to prevent detachment thereof from the EM coil 172. A suitable power source can be operably coupled to the lead wires 174 to provide electricity to the EM coil 172.

When energized, the EM coil 172 produces an electromagnetic field that is detectable by an external sensor module in a manner similar to that described in connection with FIG. 5. Note that the relative strength of the field produced by the EM coil 172 is dependent on various factors including the length of the wire from which the coils are made, number of coil windings, and the thickness of the core wire 131 over which the coil is wound. As such, it is appreciated that the electromagnetic field of the EM coil 172 can be varied by altering these and other aspects of the magnetic assembly 160.

A stylet configured in accordance with yet another embodiment is shown in FIG. 8. The stylet 130 of FIG. 8 includes the ECG sensor assembly 150 and magnetic assembly 160, as before. In contrast to the previous embodiment, the EM coil 172 is not disposed within the sleeve 142. Rather, a distal end of the sleeve 142 terminates at and abuts a proximal end of the EM coil 172. The lead wires 174 for the EM coil 172 are fed through the hollow interior of the sleeve 142 to the handle and tether.

The ECG sensor assembly 150 is disposed proximally of the magnetic assembly 160 and has a configuration differing from previous embodiments. As shown, the ECG sensor assembly 150 here includes two ECG leads 182. Each ECG lead 182, defining an annular band is disposed about a portion of an outer surface of the sleeve 142 is operably connected to a respective ECG lead wire 174. Each of the ECG lead wires 174 extends through the hollow interior of the sleeve 142 to the handle and tether, terminating at the electrical connector 156 or other suitable termination. As has been explained, the ECG leads 182 operably connect with an external ECG sensor module, via the lead wires 174 and connector 156, to enable the catheter distal end 112B to be navigated through a patient's vasculature to a predetermined location proximate the heart of the patient. The stylet 130 further includes an atraumatic tip 188 of epoxy, UV adhesive, or other suitable material.

Note that the annular band structure of the ECG leads of FIG. 8 are merely one example of leads that can be included with the stylet/catheter assembly to enable ECG signals produced by the heart to be detected and forwarded to an external ECG sensor module. As such, the depictions and accompanying descriptions herein should not be considered limiting of embodiments of the present invention in any way. Note also that the number and position of the ECG leads on the stylet or catheter can vary from what is shown and described herein.

FIGS. 9-11 depict additional possible embodiments of the stylet 130 and catheter assembly 110. In FIG. 9, the stylet distal segment 132 includes the magnetic assembly 160 and

ECG sensor assembly **150** as in FIG. **8**. In contrast to FIG. **8**, however, the ECG lead wires **184** are encapsulated within the wall of the sleeve **142** to provide strain relief for the lead wires and to facilitate ease of manufacturability. Such a configuration also frees up relatively more space in the central portion of the stylet. FIG. **10** shows an embodiment similar to that of FIG. **9**, with the sleeve **142** being extended over the EM coil **172** so as to substantially cover the entirety of the stylet distal segment **132**.

In FIG. **11**, the stylet **130** is shown disposed in the lumen **114** of the catheter **112** and including the sleeve **142** and magnetic assembly **160** in a configuration similar to that shown in FIG. **8**. In the present embodiment, however, the ECG sensor assembly **150** is not included on the stylet **130**, but rather includes the ECG leads **182** disposed on the catheter itself. Particularly, the ECG leads **182** are integrated into the wall of the catheter such that an outer surface of each lead is exposed at the outer surface of the catheter. This configuration enables the ECG leads **182** of the ECG sensor assembly **150** to serve as electrodes in the manner previously described, but on a catheter having a closed distal end as shown in FIG. **11**. The ECG lead wires **184** are electrically connected to the ECG leads **182** and disposed within the wall of the catheter itself so as to extend proximally to an external ECG sensor module or other suitable device.

Thus, placement of the ECG leads **182** at an outer catheter surface as shown in FIG. **11** enables the leads to act as electrodes and be in continual contact with the blood present in the vasculature of the patient, which blood serves as a conducting medium for the ECG signal from the heart. Note that in previous embodiments, the ECG leads disposed on the stylet itself are in contact with the blood most often via a catheter having an open proximal end. Again, it should be noted that the embodiments depicted in FIGS. **8-11** are exemplary of the various possible configurations for the stylet and its magnetic and ECG sensor assemblies, and that the type, size, and number of elements of these components may be varied as one skilled in the art will appreciate. For instance, the ECG sensor can be included on a stylet without the magnetic assembly present in one embodiment.

Attention is now directed generally to FIGS. **12-22**, which depict further examples of the distal segment **132** of the stylet **130** including both magnetic and sensor assemblies, according to present embodiments. In FIG. **12**, the distal segment **132** includes the tubing **142** inside which is disposed a distal portion of the core wire **131**, terminating at the core wire distal end **131B**. The magnetic assembly **160**, including a plurality of permanent magnets **162** or other suitable magnetic/electromagnetic elements, is disposed distally to the core wire **131**, though other positional configurations for the magnetic assembly are possible. A conductive wire **190** proximally extends within the tubing **142** from the stylet distal end **130B** to the proximal end of the stylet for connection with a suitable ECG sensor module or other suitable monitoring device. A distal end **190B** of the conductive wire **190** is substantially co-terminal with the stylet distal end **130B**, though other more proximal terminating configurations are also possible. A conductive epoxy **166** is included at the distal end of the tubing **142** to secure the conductive wire distal end **190B** and increase the conductive surface area for ECG signal monitoring by the ECG sensor, implemented here as the distal portion of the conductive wire **190**. Of course, other suitable tip configurations can be used, including atraumatic tips, tip welds, non-conductive adhesives, or nothing at all. In another embodiment, the conductive wire can be embedded within the tubing and is exposed only at the distal end of the stylet.

The embodiment of FIG. **13** is similar to that of FIG. **12**, wherein the conductive wire **190** does not extend the length of the stylet **130** but rather is connected at a proximal end **190A** thereof to the core wire **131**. Thus the conductive pathway from the conductive wire distal end **190B**, which serves as the ECG sensor, is established by the lengths of both the conductive wire **190** and the core wire **131**. The conductive wire proximal end **190A** can be secured to the core wire via a weld, adhesive, etc. This embodiment may be used, for example, where the tubing **142** does not proximally extend the entire length of the stylet **130**, but rather only along the distal segment thereof. Indeed, in the embodiments described herein, the tubing can extend along all or only a portion of the stylet length.

In FIG. **14**, a conductive coil **194** proximally extends within the tubing **142** and about the magnetic assembly **160** from the stylet distal end **130B** to a connection point with the core wire **131** at the proximal end **194A** of the coil. The conductive coil proximal end **194A** can be secured to the core wire **131** via a weld, adhesive, etc. A distal end **194B** of the conductive coil **194** is substantially co-terminal with the stylet distal end **130B**, though other more proximal terminating configurations are also possible. A conductive epoxy **166** is included at the distal end of the tubing **142** to secure the conductive coil distal end **194B** and increase the conductive surface area for ECG signal monitoring by the ECG sensor, implemented here as the distal portion of the conductive coil **194**. In other embodiments, the conductive epoxy or other suitable material can extend a greater or lesser distance into the tubing **142** than what is shown in the accompanying drawings. In another embodiment, the conductive coil can proximally extend the length of the stylet **130** for connection with a suitable ECG sensor module or other suitable monitoring device. In yet another embodiment, a distal portion of the core wire can be shaped, such as via grinding, then coiled to form a conductive coil that is integral to the core wire.

In FIG. **15**, the tubing **142** can be made electrically conductive, such as via impregnation therein of a conductive material, or by coating an inner or outer surface thereof with a conductive material. Thus a distal portion of the tubing **142** at the distal end **130B** of the stylet **130** serves as an ECG sensor and more proximal portions of the tubing define a conductive pathway for carrying the ECG signals therefrom.

In FIG. **16**, internal tubing **198** can be included within the tubing **142** of the stylet distal segment **132** as part of an ECG sensor assembly. In the present embodiment, a proximal end **198A** of the internal tubing **198** is attached to a portion of the core wire **131** via heat-shrinking, adhesive, etc., while a distal end **198B** is substantially co-terminal with the stylet distal end **130B** or is in intimate contact with the conductive epoxy **166** so as to enable the reception of ECG signals for transmission along the internal tubing **198** and core wire **131** to a suitable ECG sensor module external to the patient, as has been described.

In FIG. **17**, the tubing **142** from earlier embodiments is replaced with a conductive tubing structure, such as a metallic hypotube **202**, which attaches to the core wire **131** at a proximal end **202A** and extends to the stylet distal end **130B** of the stylet **130** where its distal end **202B** contacts the conductive epoxy **166**. The hypotube **202** can include perforations **204**, such as horizontal, vertical, round, or helical notches or through-holes completely or partially defined through the hypotube surface so as to increase flexibility of the hypotube.

Note that, in this and other embodiments, the conductive epoxy **166** or other tip configuration, such as atraumatic tips,

adhesives, tip welds, etc., can be suitable shaped as seen in FIG. 17 so as to ease advancement of the catheter and stylet through patient vasculature. In one embodiment for example, the conductive epoxy tip can be replaced by a tip including stainless steel, either pre-formed before attachment, e.g., via welding, adhesive, etc., to the stylet distal end or shaped after attachment. Such a tip can be attached directly to the stylet core wire, to another conductive wire in the stylet, or to another ECG sensor configuration.

FIG. 18 shows another tubing embodiment, wherein the tubing is defined by a conductive external coil 208, attached at a proximal end 208A thereof and extending to a distal end 208B, which is in contact with the conductive epoxy 166 at the stylet distal end 130B. A safety wire 210 can be included so as to extend between a distal portion of the core wire 131 and the distal tip epoxy 166 so as to prevent separation of the external coil 208 from the stylet 130. In another embodiment, the safety wire can be replaced with internal tubing that is disposed about the magnetic assembly 160.

In FIG. 19, the conductive epoxy 166 extends proximally from the distal end 130B of the stylet 130, contained by the tubing 142, so as to be in electrical communication with the core wire 131. Thus, a distal portion of the conductive epoxy 166 serves as an ECG sensor, while more proximal portions thereof provide a conductive pathway, together with the core wire, to enable the transmission of ECG signals through the stylet 130. Note that in another embodiment, the tubing can extend the length of the stylet.

In FIG. 20, an annular conductive ring 214 is included as an ECG sensor at the stylet distal end 130B and is connected to a lead wire 216 that extends proximally along the length of the stylet 130 for connection with a suitable ECG sensor module or other suitable device. The ring 214 can be inset into the tubing 142 and can be in electrical communication with the conductive epoxy 166. As before, the conductive epoxy can be omitted from the design. In another embodiment, the lead wire 216 can be electrically connected to the core wire instead of extending the entire length of the stylet.

In FIG. 21, a conductive coil 218 is positioned distal to and attached to the tubing 142. A tip weld 154 is formed on the stylet distal end 130B so as to electrically connect with the conductive coil 218. The conductive wire 190 extends distally from the core wire 131 to the tip weld 154 as shown in FIG. 21, or to the conductive coil 218. In another embodiment, the conductive wire can extend the length of the stylet. In yet another embodiment, the conductive coil can be replaced by a conductive hypotube, if desired, which can act as filler material for the plasma weld that forms the tip weld 154.

In FIG. 22, the core wire 130 includes a distal tip 131B that defines an atraumatic tip configuration, with the conductive epoxy 166 included to secure the distal tip to the tubing 142. Such a core wire distal tip can be formed by grinding, plasma welding, etc., and provides an ECG sensor with relatively large surface area for reception of ECG signals.

It is noted that in example embodiments, distal tips can be formed by a variety of procedures, including grinding or plasma welding as discussed in connection with FIG. 22, insertion and adhesion to the stylet of an already formed tip, insertion of a conductive slug into the stylet tubing that is then melted and formed with a die, etc. It should be further noted that the embodiments shown in the previously described drawings are merely examples of possible configurations for providing a magnetic assembly and an ECG sensor with a stylet for guidance of a catheter or other indwelling device within the body of a patient. As such, the

claims of the present disclosure should not be construed as being limited to only those embodiments explicitly described herein.

Embodiments of the present invention may be embodied in other specific forms without departing from its spirit or essential characteristics. The described embodiments are to be considered in all respects only as illustrative, not restrictive. The scope of the present disclosure is, therefore, indicated by the appended claims rather than by the foregoing description. All changes that come within the meaning and range of equivalency of the claims are to be embraced within their scope.

What is claimed is:

1. A stylet for use within a longitudinally extending lumen of a catheter, the stylet comprising:
  - an elongate core wire including a proximal segment having a first diameter and a distal segment, wherein a portion of the distal segment includes a reduced diameter section having a second diameter less than the first diameter and a tapered transition region that transitions the elongate core wire between the first diameter and the reduced diameter section;
  - a tubing portion covering a portion of both the tapered transition region and the reduced diameter section of the core wire;
  - an ECG sensor for sensing an ECG signal of a patient when the stylet is disposed within the lumen of the catheter and the catheter is disposed within a body of a patient; and
  - a magnetic assembly including at least one element capable of producing a magnetic or electromagnetic field for detection by a sensor external to the patient.
2. The stylet as defined in claim 1, wherein the ECG sensor is in operable communication with a conductive pathway for passing the ECG signal externally with respect to the patient when the catheter is disposed within the patient.
3. The stylet as defined in claim 2, wherein the ECG sensor includes a distal portion of the core wire, and wherein the conductive pathway includes portions of the core wire proximal to the distal portion.
4. The stylet as defined in claim 1, wherein the ECG sensor includes at least one of the following: an annular ring disposed on the tubing portion of the stylet; and a conductive epoxy, at least a portion of the conductive epoxy being covered by the tubing portion.
5. The stylet as defined in claim 1, wherein the tubing portion defines at least a portion of the ECG sensor.
6. The stylet as defined in claim 1, wherein the tubing portion includes a conductive coil that covers at least a portion of the magnetic assembly.
7. The stylet as defined in claim 1, wherein the ECG sensor includes a conductive wire that is separate from the core wire.
8. A method of guiding a catheter internally within a patient, the catheter defining at least one lumen in which a stylet including a magnetic assembly, an elongate core wire including a tubing sleeve covering a distal segment of the core wire, the distal segment of the core wire comprising a tapered transition region and a reduced diameter section, and an ECG sensor are removably disposed, the method comprising:
  - introducing the catheter with the stylet disposed therein into the patient;
  - detecting data relating to the magnetic assembly by an external sensor during advancement of the catheter within the patient body; and

19

monitoring ECG signals sensed by the ECG sensor of the stylet during advancement of the catheter so as to position the catheter in a desired location within the patient.

9. The method of guiding as defined in claim 8, wherein monitoring ECG signals further comprises:

monitoring ECG signals sensed by the ECG sensor of the stylet during advancement of the catheter through a vasculature of the patient so as to position the catheter proximate an SA node of the heart of the patient.

10. The method of guiding as defined in claim 8, further comprising:

withdrawing the stylet from the at least one lumen of the catheter after the catheter has been positioned in a desired location.

11. A catheter assembly, comprising:

a catheter defining a lumen; and

a stylet for removable placement in the lumen, the stylet comprising:

a core wire including a distal segment, a portion of the core wire distal segment defining a reduced diameter section and a transition region with respect to the core wire proximal to the distal segment, the core wire capable of sensing an ECG signal of a patient when the stylet is disposed within the lumen of the catheter and the catheter is disposed within a vasculature of the patient;

a tubing portion covering the distal segment of the core wire, the tubing portion being secured to the core wire near the transition region and defining an air gap between an outer surface of the core wire and an inner surface of the tubing portion; and

at least one magnetic element included in the air gap adjacent the core wire distal segment and covered by the tubing portion.

12. The catheter assembly as defined in claim 11, wherein the core wire includes nitinol and a hydrophilic coating, and wherein the catheter assembly further comprises:

an electrically conductive feature included at a distal end of the tubing portion, the electrically conductive feature in electrical communication with the core wire to

20

enable the electrically conductive feature to detect an electrical impulse from a heart of a patient when a distal portion of the stylet is disposed within a vasculature of the patient.

13. The catheter assembly as defined in claim 12, wherein the at least one magnetic element includes a plurality of permanent magnets interposed between the core wire and the tubing portion, and wherein the electrically conductive feature includes one of a conductive metal, an epoxy, and a tip weld material.

14. The catheter assembly as defined in claim 13, wherein the core wire includes a distal end and the electrically conductive feature includes a conductive epoxy that is electrically connected to the core wire proximate the distal end of the core wire, and wherein the core wire defines a conductive pathway for passage of the ECG signal to a point exterior to the catheter.

15. The stylet as defined in claim 1, wherein the tubing portion defines an air gap between an outer surface of the core wire and an inner surface of the tubing portion.

16. The stylet as defined in claim 15, wherein at least one magnetic element is interposed in the air gap between the outer surface of the core wire and an inner surface of the tubing portion.

17. The stylet as defined in claim 1, wherein the only magnetic or electronic equipment located at the distal segment of the elongate core wire are the ECG sensor and the magnetic assembly.

18. The stylet as defined in claim 17, wherein the tubing portion is directly attached to the core wire at or near the tapered transition region and is sized to match the first diameter.

19. The stylet as defined in claim 1, wherein the ECG sensor comprises the distal segment of the elongate core wire and a coil of conductive material disposed about a portion of the distal segment.

20. The stylet as defined in claim 19, wherein the coil of conductive material is bonded to the distal segment of the elongate core wire by a tip weld, wherein the tip weld is shaped to provide the stylet with an atraumatic distal tip.

\* \* \* \* \*

专利名称(译)	导管组件包括ECG传感器和磁性组件		
公开(公告)号	<a href="#">US9901714</a>	公开(公告)日	2018-02-27
申请号	US12/545762	申请日	2009-08-21
申请(专利权)人(译)	C. R. BARD. INC.		
当前申请(专利权)人(译)	C. R. BARD , INC.		
[标]发明人	LEMON RYAN R BOWN MATTHEW W		
发明人	LEMON, RYAN R. BOWN, MATTHEW W.		
IPC分类号	A61B5/00 A61B5/042 A61M25/09 A61M25/01 A61B17/00 A61B34/20 A61M25/00		
CPC分类号	A61M25/09 A61B5/042 A61M25/0102 A61B2017/00044 A61B2017/00331 A61M2205/3507 A61M25/0054 A61M2025/09116 A61M2025/09141 A61M2025/09175 A61M2025/09183 A61B2034/2051		
代理机构(译)	鲁坦和塔克LLP		
优先权	61/091233 2008-08-22 US 61/095451 2008-09-09 US		
其他公开文献	US20100222664A1		
外部链接	<a href="#">Espacenet</a> <a href="#">USPTO</a>		

摘要(译)

用于将导管的远侧末端引导至患者身体内的预定位置的管心针。在一个实施例中，探针配置成用于导管的管腔内并且包括芯线，ECG传感器和磁性组件。当探针布置在导管的内腔内并且导管布置在患者的体内时，ECG传感器感测患者的ECG信号。磁性组件包括至少一个能够产生磁场或电磁场的元件，用于由患者外部的传感器进行检测。在另一个实施例中，管心针包括相对于管心针的更近侧部分偏转的预成形的远侧节段，当管心针接纳在管腔内时，这又导致导管的远侧段偏转。

