

US008684925B2

(12) **United States Patent**
Manicka et al.

(10) **Patent No.:** **US 8,684,925 B2**
(45) **Date of Patent:** **Apr. 1, 2014**

(54) **INJECTABLE DEVICE FOR PHYSIOLOGICAL MONITORING**
(75) Inventors: **Yatheendhar D. Manicka**, Woodbury, MN (US); **Badri Amurthur**, Los Gatos, CA (US); **Mark Bly**, Falcon Heights, MN (US); **Kristofer James**, Eagan, MN (US); **Imad Libbus**, Saint Paul, MN (US); **Scott Mazar**, Woodbury, MN (US); **Jerry Wang**, Blaine, MN (US)

(73) Assignee: **Corventis, Inc.**, San Jose, CA (US)
(*) Notice: Subject to any disclaimer, the term of this patent is extended or adjusted under 35 U.S.C. 154(b) by 1136 days.

(21) Appl. No.: **12/209,430**

(22) Filed: **Sep. 12, 2008**

(65) **Prior Publication Data**
US 2009/0076348 A1 Mar. 19, 2009

Related U.S. Application Data

(60) Provisional application No. 61/055,666, filed on May 23, 2008, provisional application No. 60/972,537, filed on Sep. 14, 2007, provisional application No. 60/972,329, filed on Sep. 14, 2007, provisional application No. 60/972,354, filed on Sep. 14, 2007, provisional application No. 60/972,336, filed on Sep. 14, 2007.

(51) **Int. Cl.**
A61B 5/00 (2006.01)
A61B 5/145 (2006.01)

(52) **U.S. Cl.**
CPC **A61B 5/14503** (2013.01); **A61B 2560/0214** (2013.01); **A61B 2560/0468** (2013.01); **A61B 2562/16** (2013.01)
USPC **600/301**

(58) **Field of Classification Search**
None
See application file for complete search history.

(56) **References Cited**
U.S. PATENT DOCUMENTS
834,261 A 10/1906 Chambers
2,087,124 A 7/1937 Smith et al.
2,184,511 A 12/1939 Bagno et al.
3,170,459 A 2/1965 Phipps et al.
3,232,291 A 2/1966 Parker

(Continued)

FOREIGN PATENT DOCUMENTS
AU 2003-220574 A8 10/2003
EP 1487535 12/2004

(Continued)

OTHER PUBLICATIONS

Miller, P.Z., Home monitoring for congestive heart failure patients, Caring Magazine, pp. 53-54, Aug. 1995.

(Continued)

Primary Examiner — Bill Thomson
Assistant Examiner — Bobby Soriano

(74) *Attorney, Agent, or Firm* — Kilpatrick Townsend & Stockton LLP

(57) **ABSTRACT**
An injectable detecting device is provided for use in physiological monitoring. The device includes a plurality of sensors axially spaced along a body that provide an indication of at least one physiological event of a patient, a monitoring unit within the body coupled to the plurality of sensors configured to receive data from the plurality of sensors and create processed patient data, a power source within the body coupled to the monitoring unit, and a communication antenna external to the body coupled to the monitoring unit configured to transfer data to/from other devices.

26 Claims, 15 Drawing Sheets

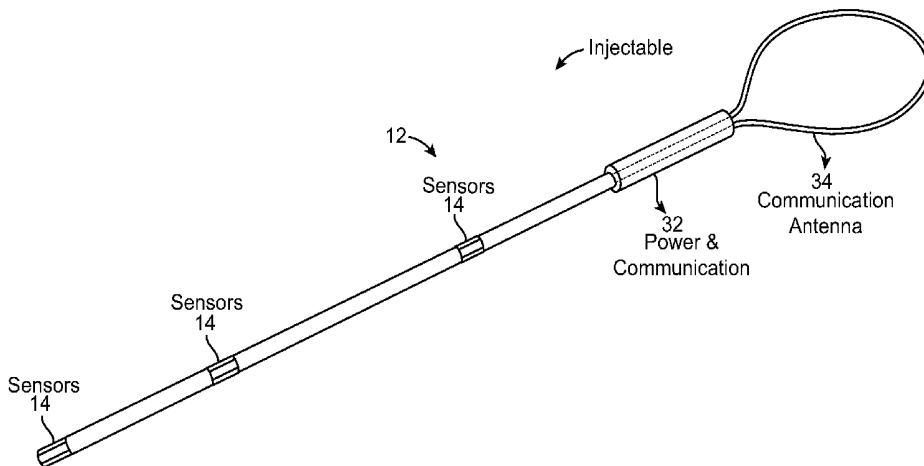

(56)

References Cited

U.S. PATENT DOCUMENTS

3,370,459 A	2/1968	Cescati	5,319,363 A	6/1994	Welch et al.
3,517,999 A	6/1970	Weaver	5,331,966 A	7/1994	Bennett et al.
3,620,216 A	11/1971	Szymanski	5,335,664 A	8/1994	Nagashima
3,677,260 A	7/1972	Funfstuck et al.	5,343,869 A	9/1994	Pross et al.
3,805,769 A	4/1974	Sessions	5,353,793 A	10/1994	Bornn
3,845,757 A	11/1974	Weyer	5,362,069 A	11/1994	Hall-Tipping
3,874,368 A	4/1975	Asrican	5,375,604 A	12/1994	Kelly et al.
3,882,853 A	5/1975	Gofman et al.	5,411,530 A	5/1995	Akhtar
3,942,517 A	3/1976	Bowles et al.	5,437,285 A	8/1995	Verrier et al.
3,972,329 A	8/1976	Kaufman	5,443,073 A	8/1995	Wang et al.
4,008,712 A	2/1977	Nyboer	5,449,000 A	9/1995	Libke et al.
4,024,312 A	5/1977	Korpman	5,450,845 A	9/1995	Axelgaard
4,077,406 A	3/1978	Sandhage et al.	5,454,377 A	10/1995	Dzwonczyk et al.
4,121,573 A	10/1978	Crovella et al.	5,464,012 A	11/1995	Falcone
4,141,366 A	2/1979	Cross, Jr. et al.	5,469,859 A	11/1995	Tsoglin et al.
RE30,101 E	9/1979	Kubicek et al.	5,482,036 A	1/1996	Diab et al.
4,185,621 A	1/1980	Morrow	5,503,157 A	4/1996	Sramek
4,216,462 A	8/1980	McGrath et al.	5,511,548 A	4/1996	Raizzi et al.
4,300,575 A	11/1981	Wilson	5,511,553 A	4/1996	Segalowitz
4,308,872 A	1/1982	Watson et al.	5,518,001 A	5/1996	Snell
4,358,678 A	11/1982	Lawrence	5,523,742 A	6/1996	Simkins et al.
4,409,983 A	10/1983	Albert	5,529,072 A	6/1996	Sramek
4,450,527 A	5/1984	Sramek	5,544,661 A	8/1996	Davis et al.
4,451,254 A	5/1984	Dinius et al.	5,558,638 A	9/1996	Evers et al.
4,478,223 A	10/1984	Allor	5,560,368 A	10/1996	Berger
4,498,479 A	2/1985	Martio et al.	5,564,429 A	10/1996	Bornn et al.
4,522,211 A	6/1985	Bare et al.	5,564,434 A	10/1996	Halperin et al.
4,661,103 A	4/1987	Harman	5,566,671 A	10/1996	Lyons
4,664,129 A	5/1987	Helzel et al.	5,575,284 A	11/1996	Athan et al.
4,669,480 A	6/1987	Hoffman	5,607,454 A	3/1997	Cameron et al.
4,673,387 A	6/1987	Phillips et al.	5,632,272 A	5/1997	Diab et al.
4,681,118 A	7/1987	Asai et al.	5,634,468 A	6/1997	Platt et al.
4,692,685 A	9/1987	Blaze	5,642,734 A	7/1997	Ruben et al.
4,699,146 A	10/1987	Sieverding	5,673,704 A	10/1997	Marchlinski et al.
4,721,110 A	1/1988	Lampadius	5,678,562 A	10/1997	Sellers
4,730,611 A	3/1988	Lamb	5,687,717 A	11/1997	Halpern et al.
4,733,107 A	3/1988	O'Shaughnessy et al.	5,718,234 A	2/1998	Warden et al.
4,781,200 A	11/1988	Baker	5,724,025 A	3/1998	Tavori
4,793,362 A	12/1988	Tedner	5,738,107 A	4/1998	Martinsen et al.
4,838,273 A	6/1989	Cartmell	5,748,103 A	5/1998	Flach et al.
4,838,279 A	6/1989	Fore	5,767,791 A	6/1998	Stoop et al.
4,850,370 A	7/1989	Dower	5,769,793 A	6/1998	Pincus et al.
4,880,004 A	11/1989	Baker, Jr. et al.	5,772,508 A	6/1998	Sugita et al.
4,895,163 A	1/1990	Libke et al.	5,772,586 A	6/1998	Heinonen et al.
4,911,175 A	3/1990	Shizgal	5,778,882 A	7/1998	Raymond et al.
4,945,916 A	8/1990	Kretschmer et al.	5,788,643 A	8/1998	Feldman
4,955,381 A	9/1990	Way et al.	5,803,915 A	9/1998	Kremenchugsky et al.
4,966,158 A	10/1990	Honma et al.	5,807,272 A	9/1998	Kun
4,981,139 A	1/1991	Pfohl	5,814,079 A	9/1998	Kieval et al.
4,988,335 A	1/1991	Prindle et al.	5,817,035 A	10/1998	Sullivan
4,989,612 A	2/1991	Fore	5,833,603 A	11/1998	Kovacs et al.
5,001,632 A	3/1991	Hall-Tipping	5,836,990 A	11/1998	Li
5,012,810 A	5/1991	Strand et al.	5,855,614 A	1/1999	Stevens et al.
5,025,791 A	6/1991	Niwa	5,860,860 A	1/1999	Clayman
5,027,824 A	7/1991	Dougherty et al.	5,862,802 A	1/1999	Bird
5,050,612 A	9/1991	Matsumura	5,862,803 A	1/1999	Besson et al.
5,063,937 A	11/1991	Ezenwa et al.	5,865,733 A	2/1999	Malinouskas et al.
5,080,099 A	1/1992	Way et al.	5,876,353 A	3/1999	Riff
5,083,563 A	1/1992	Collins	5,904,708 A	5/1999	Goedeke
5,086,781 A	2/1992	Bookspan	5,935,079 A	8/1999	Swanson et al.
5,113,869 A	5/1992	Nappholz et al.	5,941,831 A	8/1999	Turcott
5,125,412 A	6/1992	Thornton	5,944,659 A	8/1999	Flach et al.
5,133,355 A	7/1992	Strand et al.	5,949,636 A	9/1999	Johnson et al.
5,140,985 A	8/1992	Schroeder et al.	5,957,854 A	9/1999	Besson et al.
5,150,708 A	9/1992	Brooks	5,957,861 A	9/1999	Combs et al.
5,168,874 A	12/1992	Segalowitz	5,964,703 A	10/1999	Goodman et al.
5,226,417 A	7/1993	Swedlow et al.	5,970,986 A	10/1999	Bolz et al.
5,241,300 A	8/1993	Buschmann	5,984,102 A	11/1999	Tay
5,257,627 A	11/1993	Rapoport	5,987,352 A	11/1999	Klein et al.
5,271,411 A	12/1993	Ripley et al.	6,007,532 A	12/1999	Netherly
5,273,532 A	12/1993	Niezink et al.	6,027,523 A	2/2000	Schmieding
5,282,840 A	2/1994	Hudrlik	6,045,513 A	4/2000	Stone et al.
5,291,013 A	3/1994	Nafarrate et al.	6,047,203 A	4/2000	Sackner et al.
5,297,556 A	3/1994	Shankar	6,047,259 A	4/2000	Campbell et al.
5,301,677 A	4/1994	Hsung	6,049,730 A	4/2000	Kristbjarnarson
			6,050,267 A	4/2000	Nardella et al.
			6,050,951 A	4/2000	Friedman et al.
			6,052,615 A	4/2000	Feild et al.
			6,067,467 A	5/2000	John

(56)

References Cited

U.S. PATENT DOCUMENTS

6,080,106	A	6/2000	Lloyd et al.	6,577,893	B1	6/2003	Besson et al.
6,081,735	A	6/2000	Diab et al.	6,577,897	B1	6/2003	Shurubura et al.
6,095,991	A	8/2000	Krausman et al.	6,579,231	B1	6/2003	Phipps
6,102,856	A	8/2000	Groff et al.	6,580,942	B1	6/2003	Willshire
6,104,949	A	8/2000	Pitts Crick et al.	6,584,343	B1	6/2003	Ransbury et al.
6,112,224	A	8/2000	Peifer et al.	6,587,715	B2	7/2003	Singer
6,117,077	A	9/2000	Del Mar et al.	6,589,170	B1	7/2003	Flach et al.
6,125,297	A	9/2000	Siconolfi	6,595,927	B2	7/2003	Pitts-Crick et al.
6,129,744	A	10/2000	Boute	6,595,929	B2	7/2003	Stivoric et al.
6,141,575	A	10/2000	Price	6,600,949	B1	7/2003	Turcott
6,144,878	A	11/2000	Schroepfel et al.	6,602,201	B1	8/2003	Hepp et al.
6,164,284	A	12/2000	Schulman et al.	6,605,038	B1	8/2003	Teller et al.
6,181,963	B1	1/2001	Chin et al.	6,611,705	B2	8/2003	Hopman et al.
6,185,452	B1	2/2001	Schulman et al.	6,616,606	B1	9/2003	Petersen et al.
6,190,313	B1	2/2001	Hinkle	6,622,042	B1	9/2003	Thacker
6,190,324	B1	2/2001	Kieval et al.	6,636,754	B1	10/2003	Baura et al.
6,198,394	B1	3/2001	Jacobsen et al.	6,641,542	B2	11/2003	Cho et al.
6,198,955	B1	3/2001	Axelgaard et al.	6,645,153	B2	11/2003	Kroll et al.
6,208,894	B1	3/2001	Schulman et al.	6,649,829	B2	11/2003	Garber et al.
6,212,427	B1	4/2001	Hoover	6,650,917	B2	11/2003	Diab et al.
6,213,942	B1	4/2001	Flach et al.	6,658,300	B2	12/2003	Govari et al.
6,225,901	B1	5/2001	Kail, IV	6,659,947	B1	12/2003	Carter et al.
6,245,021	B1	6/2001	Stampfer	6,659,949	B1	12/2003	Lang et al.
6,259,939	B1	7/2001	Rogel	6,687,540	B2	2/2004	Marcovecchio
6,272,377	B1	8/2001	Sweeney et al.	6,697,658	B2	2/2004	Al-Ali
6,277,078	B1	8/2001	Porat et al.	RE38,476	E	3/2004	Diab et al.
6,287,252	B1	9/2001	Lugo	6,699,200	B2	3/2004	Cao et al.
6,289,238	B1	9/2001	Besson et al.	6,701,271	B2	3/2004	Willner et al.
6,290,646	B1	9/2001	Cosentino et al.	6,711,423	B2 *	3/2004	Colvin, Jr. 600/317
6,295,466	B1	9/2001	Ishikawa et al.	6,714,813	B2	3/2004	Ishigooka et al.
6,305,943	B1	10/2001	Pougatchev et al.	RE38,492	E	4/2004	Diab et al.
6,306,088	B1	10/2001	Krausman et al.	6,721,594	B2	4/2004	Conley et al.
6,308,094	B1	10/2001	Shusterman et al.	6,728,572	B2	4/2004	Hsu et al.
6,312,378	B1	11/2001	Bardy	6,748,269	B2	6/2004	Thompson et al.
6,315,721	B2	11/2001	Schulman et al.	6,749,566	B2	6/2004	Russ
6,327,487	B1	12/2001	Stratbucker	6,751,498	B1	6/2004	Greenberg et al.
6,330,464	B1 *	12/2001	Colvin et al. 600/316	6,760,617	B2	7/2004	Ward et al.
6,336,903	B1	1/2002	Bardy	6,773,396	B2	8/2004	Flach et al.
6,339,722	B1	1/2002	Heethaar et al.	6,775,566	B2	8/2004	Nissila
6,343,140	B1	1/2002	Brooks	6,790,178	B1	9/2004	Mault et al.
6,347,245	B1	2/2002	Lee et al.	6,795,722	B2	9/2004	Sheraton et al.
6,358,208	B1	3/2002	Lang et al.	6,814,706	B2	11/2004	Barton et al.
6,385,473	B1	5/2002	Haines et al.	6,816,744	B2	11/2004	Garfield et al.
6,398,727	B1	6/2002	Bui et al.	6,821,249	B2	11/2004	Casscells, III et al.
6,400,982	B2	6/2002	Sweeney et al.	6,824,515	B2	11/2004	Suorsa et al.
6,409,674	B1	6/2002	Brockway et al.	6,827,690	B2	12/2004	Bardy
6,411,853	B1	6/2002	Millot et al.	6,829,503	B2	12/2004	Alt
6,416,471	B1	7/2002	Kumar et al.	6,858,006	B2	2/2005	MacCarter et al.
6,440,069	B1 *	8/2002	Raymond et al. 600/300	6,871,211	B2	3/2005	Labounty et al.
6,442,422	B1	8/2002	Duckert	6,878,121	B2	4/2005	Krausman et al.
6,450,820	B1	9/2002	Palsson et al.	6,879,850	B2	4/2005	Kimball
6,450,953	B1	9/2002	Place et al.	6,881,191	B2	4/2005	Oakley et al.
6,454,707	B1	9/2002	Casscells, III et al.	6,887,201	B2	5/2005	Bardy
6,454,708	B1	9/2002	Ferguson et al.	6,890,096	B2	5/2005	Tokita et al.
6,459,930	B1	10/2002	Takehara et al.	6,893,396	B2	5/2005	Schulze et al.
6,463,328	B1	10/2002	John	6,894,204	B2	5/2005	Dunshee
6,473,640	B1	10/2002	Erlebacher	6,906,530	B2	6/2005	Geisel
6,480,733	B1	11/2002	Turcott	6,912,414	B2	6/2005	Tong
6,480,734	B1	11/2002	Zhang et al.	6,936,006	B2	8/2005	Sabra
6,490,478	B1	12/2002	Zhang et al.	6,940,403	B2	9/2005	Kail, IV
6,491,647	B1	12/2002	Bridger et al.	6,942,622	B1	9/2005	Turcott
6,494,829	B1	12/2002	New, Jr. et al.	6,952,695	B1	10/2005	Trinks et al.
6,496,715	B1	12/2002	Lee et al.	6,970,742	B2	11/2005	Mann et al.
6,512,949	B1	1/2003	Combs et al.	6,972,683	B2	12/2005	Lestienne et al.
6,520,967	B1	2/2003	Cauthen	6,978,177	B1	12/2005	Chen et al.
6,527,711	B1	3/2003	Stivoric et al.	6,980,851	B2	12/2005	Zhu et al.
6,527,729	B1	3/2003	Turcott	6,980,852	B2	12/2005	Jersey-Willuhn et al.
6,544,173	B2	4/2003	West et al.	6,985,078	B2	1/2006	Suzuki et al.
6,544,174	B2	4/2003	West et al.	6,987,965	B2	1/2006	Ng et al.
6,551,251	B2	4/2003	Zuckerwar et al.	6,988,989	B2	1/2006	Weiner et al.
6,551,252	B2	4/2003	Sackner et al.	6,993,378	B2	1/2006	Wiederhold et al.
6,569,160	B1	5/2003	Goldin et al.	6,997,879	B1	2/2006	Turcott
6,572,557	B2	6/2003	Tchou et al.	7,003,346	B2	2/2006	Singer
6,572,636	B1	6/2003	Hagen et al.	7,009,362	B2 *	3/2006	Tsukamoto et al. 320/107
6,577,139	B2	6/2003	Cooper	7,010,340	B2 *	3/2006	Scarantino et al. 600/436
				7,018,338	B2	3/2006	Vetter et al.
				7,020,508	B2	3/2006	Stivoric et al.
				7,027,862	B2	4/2006	Dahl et al.
				7,041,062	B2	5/2006	Friedrichs et al.

(56)

References Cited

U.S. PATENT DOCUMENTS

7,044,911 B2	5/2006	Drinan et al.	2002/0138017 A1	9/2002	Bui et al.
7,047,067 B2	5/2006	Gray et al.	2002/0167389 A1	11/2002	Uchikoba et al.
7,050,846 B2	5/2006	Sweeney et al.	2003/0009092 A1	1/2003	Parker
7,054,679 B2	5/2006	Hirsh	2003/0023184 A1	1/2003	Pitts-Crick et al.
7,059,767 B2	6/2006	Tokita et al.	2003/0028221 A1	2/2003	Zhu et al.
7,088,242 B2	8/2006	Aupperle et al.	2003/0028321 A1	2/2003	Brunner et al.
7,113,826 B2	9/2006	Henry et al.	2003/0051144 A1	3/2003	Williams
7,118,531 B2	10/2006	Krill	2003/0055460 A1	3/2003	Owen et al.
7,127,370 B2	10/2006	Kelly, Jr. et al.	2003/0083581 A1	5/2003	Taha et al.
7,129,836 B2	10/2006	Lawson et al.	2003/0085717 A1	5/2003	Cooper
7,130,396 B2	10/2006	Rogers et al.	2003/0087244 A1	5/2003	McCarthy
7,130,679 B2	10/2006	Parsonnet et al.	2003/0092975 A1	5/2003	Casscells, III et al.
7,133,716 B2	11/2006	Kraemer et al.	2003/0093125 A1	5/2003	Zhu et al.
7,136,697 B2	11/2006	Singer	2003/0093298 A1	5/2003	Hernandez et al.
7,136,703 B1	11/2006	Cappa et al.	2003/0100367 A1	5/2003	Cooke
7,142,907 B2	11/2006	Xue et al.	2003/0105411 A1	6/2003	Smallwood et al.
7,149,574 B2	12/2006	Yun et al.	2003/0135127 A1	7/2003	Sackner et al.
7,149,773 B2	12/2006	Haller et al.	2003/0143544 A1	7/2003	McCarthy
7,153,262 B2	12/2006	Stivoric et al.	2003/0149349 A1	8/2003	Jensen
7,156,807 B2	1/2007	Carter et al.	2003/0187370 A1	10/2003	Kodama
7,156,808 B2	1/2007	Quy	2003/0191503 A1	10/2003	Zhu et al.
7,160,252 B2	1/2007	Cho et al.	2003/0212319 A1	11/2003	Magill
7,160,253 B2	1/2007	Nissila	2003/0221687 A1	12/2003	Kaigler
7,166,063 B2	1/2007	Rahman et al.	2003/0233129 A1	12/2003	Matos
7,167,743 B2	1/2007	Heruth et al.	2004/0006279 A1	1/2004	Arad (Abboud)
7,184,821 B2	2/2007	Belalcazar et al.	2004/0010303 A1	1/2004	Bolea et al.
7,191,000 B2	3/2007	Zhu et al.	2004/0015058 A1	1/2004	Besson et al.
7,194,306 B1	3/2007	Turcott	2004/0019292 A1	1/2004	Drinan et al.
7,206,630 B1	4/2007	Tarler	2004/0044293 A1	3/2004	Burton
7,212,849 B2	5/2007	Zhang et al.	2004/0049132 A1	3/2004	Barron et al.
7,215,984 B2	5/2007	Diab et al.	2004/0064133 A1	4/2004	Miller et al.
7,215,991 B2	5/2007	Besson et al.	2004/0068204 A1 *	4/2004	Imran et al. 600/593
7,238,159 B2	7/2007	Banet et al.	2004/0073094 A1	4/2004	Baker
7,248,916 B2	7/2007	Bardy	2004/0073126 A1	4/2004	Rowlandson
7,251,524 B1	7/2007	Hepp et al.	2004/0077954 A1	4/2004	Oakley et al.
7,257,438 B2	8/2007	Kinast	2004/0100376 A1	5/2004	Lye et al.
7,261,690 B2	8/2007	Teller et al.	2004/0102683 A1	5/2004	Khanuja et al.
7,277,741 B2	10/2007	Debreczeny et al.	2004/0106951 A1	6/2004	Edman et al.
7,284,904 B2	10/2007	Tokita et al.	2004/0122489 A1	6/2004	Mazar et al.
7,285,090 B2	10/2007	Stivoric et al.	2004/0127790 A1	7/2004	Lang et al.
7,294,105 B1	11/2007	Islam	2004/0133079 A1	7/2004	Mazar et al.
7,295,877 B2 *	11/2007	Govari 607/60	2004/0133081 A1	7/2004	Teller et al.
7,295,879 B2	11/2007	Denker et al.	2004/0134496 A1	7/2004	Cho et al.
7,297,119 B2	11/2007	Westbrook et al.	2004/0143170 A1	7/2004	DuRousseau
7,318,808 B2	1/2008	Tarassenko et al.	2004/0147969 A1	7/2004	Mann et al.
7,319,386 B2	1/2008	Collins, Jr. et al.	2004/0152956 A1	8/2004	Korman
7,336,187 B2	2/2008	Hubbard, Jr. et al.	2004/0158132 A1	8/2004	Zaleski
7,346,380 B2	3/2008	Axelgaard et al.	2004/0167389 A1	8/2004	Brabrand
7,382,247 B2	6/2008	Welch et al.	2004/0172080 A1	9/2004	Stadler et al.
7,384,398 B2	6/2008	Gagnadre et al.	2004/0199056 A1	10/2004	Husemann et al.
7,390,299 B2	6/2008	Weiner et al.	2004/0215240 A1	10/2004	Lovett et al.
7,395,106 B2	7/2008	Ryu et al.	2004/0215247 A1	10/2004	Bolz
7,423,526 B2	9/2008	Despotis	2004/0220639 A1	11/2004	Mulligan et al.
7,423,537 B2	9/2008	Bonnet et al.	2004/0225199 A1	11/2004	Evanyk et al.
7,443,302 B2	10/2008	Reeder et al.	2004/0225203 A1	11/2004	Jemison et al.
7,450,024 B2	11/2008	Wildman et al.	2004/0243018 A1	12/2004	Organ et al.
7,468,032 B2	12/2008	Stahmann et al.	2004/0267142 A1	12/2004	Paul
7,510,699 B2 *	3/2009	Black et al. 424/9.6	2005/0015094 A1	1/2005	Keller
7,701,227 B2	4/2010	Saulnier et al.	2005/0015095 A1	1/2005	Keller
7,813,778 B2 *	10/2010	Benaron et al. 600/323	2005/0020935 A1	1/2005	Helzel et al.
7,881,763 B2 *	2/2011	Brauker et al. 600/345	2005/0027175 A1	2/2005	Yang
7,942,824 B1	5/2011	Kayyali et al.	2005/0027204 A1	2/2005	Kligfield et al.
8,160,680 B2 *	4/2012	Boyden et al. 600/476	2005/0027207 A1	2/2005	Westbrook et al.
2001/0047127 A1	11/2001	New, Jr. et al.	2005/0027330 A1 *	2/2005	Govari 607/60
2002/0019586 A1	2/2002	Teller et al.	2005/0027918 A1	2/2005	Govindarajulu et al.
2002/0019588 A1	2/2002	Marro et al.	2005/0043675 A1	2/2005	Pastore et al.
2002/0022786 A1	2/2002	Takehara et al.	2005/0054944 A1	3/2005	Nakada et al.
2002/0028989 A1	3/2002	Pelletier et al.	2005/0059867 A1	3/2005	Chung
2002/0032581 A1	3/2002	Reitberg	2005/0065445 A1	3/2005	Arzbaecher et al.
2002/0045836 A1	4/2002	Alkawwas	2005/0065571 A1	3/2005	Imran
2002/0088465 A1	7/2002	Hill	2005/0070768 A1	3/2005	Zhu et al.
2002/0099277 A1	7/2002	Harry et al.	2005/0070778 A1	3/2005	Lackey et al.
2002/0116009 A1	8/2002	Fraser et al.	2005/0079132 A1 *	4/2005	Wang et al. 424/1.11
2002/0123672 A1	9/2002	Christophersom et al.	2005/0080346 A1	4/2005	Gianchandani et al.
2002/0123674 A1	9/2002	Plicchi et al.	2005/0080460 A1	4/2005	Wang et al.
			2005/0080463 A1	4/2005	Stahmann et al.
			2005/0085734 A1	4/2005	Tehrani
			2005/0091338 A1	4/2005	de la Hueraga
			2005/0096513 A1	5/2005	Ozguz et al.

(56)

References Cited

U.S. PATENT DOCUMENTS

2005/010780	A1 *	5/2005	Wang et al. 623/1.44	2006/0155183	A1	7/2006	Kroecker et al.
2005/0113703	A1	5/2005	Farringdon et al.	2006/0155200	A1	7/2006	Ng
2005/0124878	A1	6/2005	Sharony	2006/0161073	A1	7/2006	Singer
2005/0124901	A1	6/2005	Misczynski et al.	2006/0161205	A1	7/2006	Mitrani et al.
2005/0124908	A1	6/2005	Belalcazar et al.	2006/0161459	A9	7/2006	Rosenfeld et al.
2005/0131288	A1	6/2005	Turner et al.	2006/0173257	A1	8/2006	Nagai et al.
2005/0137464	A1	6/2005	Bomba	2006/0173269	A1	8/2006	Glossop
2005/0137626	A1	6/2005	Pastore et al.	2006/0195020	A1	8/2006	Martin et al.
2005/0148895	A1	7/2005	Misczynski et al.	2006/0195039	A1	8/2006	Drew et al.
2005/0158539	A1	7/2005	Murphy et al.	2006/0195097	A1	8/2006	Evans et al.
2005/0177038	A1	8/2005	Kolpin et al.	2006/0195144	A1	8/2006	Giftakis et al.
2005/0187482	A1	8/2005	O'Brien et al.	2006/0202816	A1	9/2006	Crump et al.
2005/0187796	A1	8/2005	Rosenfeld et al.	2006/0212097	A1	9/2006	Varadan et al.
2005/0192488	A1	9/2005	Bryenton et al.	2006/0224051	A1	10/2006	Teller et al.
2005/0197654	A1	9/2005	Edman et al.	2006/0224072	A1	10/2006	Shennib
2005/0203433	A1	9/2005	Singer	2006/0224079	A1	10/2006	Washchuk
2005/0203435	A1	9/2005	Nakada	2006/0235281	A1	10/2006	Tuccillo
2005/0203436	A1	9/2005	Davies	2006/0235316	A1	10/2006	Ungless et al.
2005/0203637	A1	9/2005	Edman et al.	2006/0235489	A1	10/2006	Drew et al.
2005/0206518	A1	9/2005	Welch et al.	2006/0241641	A1	10/2006	Albans et al.
2005/0215914	A1	9/2005	Bornzin et al.	2006/0241701	A1	10/2006	Markowitz et al.
2005/0215918	A1	9/2005	Frantz et al.	2006/0241722	A1	10/2006	Thacker et al.
2005/0228234	A1	10/2005	Yang	2006/0247545	A1	11/2006	St. Martin
2005/0228238	A1	10/2005	Monitzer	2006/0252999	A1	11/2006	Devaul et al.
2005/0228244	A1	10/2005	Banet	2006/0253005	A1	11/2006	Drinan et al.
2005/0239493	A1	10/2005	Batkin et al.	2006/0253044	A1	11/2006	Zhang et al.
2005/0240087	A1	10/2005	Keenan et al.	2006/0258952	A1	11/2006	Stahmann et al.
2005/0251044	A1	11/2005	Hocotr et al.	2006/0264730	A1	11/2006	Stivoric et al.
2005/0256418	A1	11/2005	Mietus et al.	2006/0264767	A1	11/2006	Shennib
2005/0261598	A1	11/2005	Banet et al.	2006/0264776	A1	11/2006	Stahmann et al.
2005/0261743	A1	11/2005	Kroll	2006/0271116	A1	11/2006	Stahmann et al.
2005/0267376	A1	12/2005	Marossero et al.	2006/0276714	A1	12/2006	Holt et al.
2005/0267377	A1	12/2005	Marossero et al.	2006/0281981	A1	12/2006	Jang et al.
2005/0267381	A1	12/2005	Benditt et al.	2006/0281996	A1	12/2006	Kuo et al.
2005/0273023	A1	12/2005	Bystrom et al.	2006/0293571	A1	12/2006	Bao et al.
2005/0277841	A1	12/2005	Shennib	2006/0293609	A1	12/2006	Stahmann et al.
2005/0277842	A1	12/2005	Silva	2007/0010702	A1 *	1/2007	Wang et al. 600/8
2005/0277992	A1	12/2005	Koh et al.	2007/0010721	A1	1/2007	Chen et al.
2005/0280531	A1	12/2005	Fadem et al.	2007/0010750	A1	1/2007	Ueno et al.
2005/0283197	A1	12/2005	Daum et al.	2007/0015973	A1	1/2007	Nanikashvili
2005/0288601	A1	12/2005	Wood et al.	2007/0015976	A1	1/2007	Miesel et al.
2006/0004300	A1	1/2006	Kennedy	2007/0016089	A1	1/2007	Fischell et al.
2006/0004377	A1	1/2006	Keller	2007/0021678	A1	1/2007	Beck et al.
2006/0009697	A1	1/2006	Banet et al.	2007/0021790	A1	1/2007	Kieval et al.
2006/0009701	A1	1/2006	Nissila et al.	2007/0021792	A1	1/2007	Kieval et al.
2006/0010090	A1	1/2006	Brockway et al.	2007/0021794	A1	1/2007	Kieval et al.
2006/0020218	A1	1/2006	Freeman et al.	2007/0021796	A1	1/2007	Kieval et al.
2006/0025661	A1	2/2006	Sweeney et al.	2007/0021797	A1	1/2007	Kieval et al.
2006/0030781	A1	2/2006	Shennib	2007/0021798	A1	1/2007	Kieval et al.
2006/0030782	A1	2/2006	Shennib	2007/0021799	A1	1/2007	Kieval et al.
2006/0031102	A1	2/2006	Teller et al.	2007/0027388	A1	2/2007	Chou
2006/0041280	A1	2/2006	Stahmann et al.	2007/0027497	A1	2/2007	Parnis
2006/0047215	A1	3/2006	Newman et al.	2007/0032749	A1 *	2/2007	Overall et al. 600/595
2006/0052678	A1	3/2006	Drinan et al.	2007/0038038	A1	2/2007	Stivoric et al.
2006/0058543	A1	3/2006	Walter et al.	2007/0038078	A1	2/2007	Osadchy
2006/0058593	A1	3/2006	Drinan et al.	2007/0038255	A1	2/2007	Kieval et al.
2006/0064030	A1	3/2006	Cosentino et al.	2007/0038262	A1	2/2007	Kieval et al.
2006/0064040	A1	3/2006	Berger et al.	2007/0043301	A1	2/2007	Martinsen et al.
2006/0064142	A1	3/2006	Chavan et al.	2007/0043303	A1	2/2007	Osyпка et al.
2006/0066449	A1	3/2006	Johnson	2007/0048224	A1	3/2007	Howell et al.
2006/0074283	A1	4/2006	Henderson et al.	2007/0060800	A1	3/2007	Drinan et al.
2006/0074462	A1	4/2006	Verhoef	2007/0060802	A1	3/2007	Ghevondian et al.
2006/0075257	A1	4/2006	Martis et al.	2007/0073132	A1	3/2007	Vosch
2006/0084881	A1	4/2006	Korzinov et al.	2007/0073168	A1	3/2007	Zhang et al.
2006/0085049	A1	4/2006	Cory et al.	2007/0073181	A1	3/2007	Pu et al.
2006/0089679	A1	4/2006	Zhu et al.	2007/0073361	A1	3/2007	Goren et al.
2006/0094948	A1	5/2006	Gough et al.	2007/0082189	A1	4/2007	Gillette
2006/0102476	A1	5/2006	Niwa et al.	2007/0083092	A1	4/2007	Rippo et al.
2006/0116592	A1	6/2006	Zhou et al.	2007/0092862	A1	4/2007	Gerber
2006/0122474	A1	6/2006	Teller et al.	2007/0104840	A1	5/2007	Singer
2006/0135858	A1	6/2006	Nidd et al.	2007/0106132	A1	5/2007	Elhag et al.
2006/0142654	A1	6/2006	Rytky	2007/0106137	A1	5/2007	Baker, Jr. et al.
2006/0142820	A1	6/2006	Von Arx et al.	2007/0106167	A1	5/2007	Kinast
2006/0149168	A1	7/2006	Czarnek	2007/0118039	A1	5/2007	Bodecker et al.
2006/0155174	A1 *	7/2006	Glukhovskiy et al. 600/301	2007/0123756	A1	5/2007	Kitajima et al.
				2007/0123903	A1	5/2007	Raymond et al.
				2007/0123904	A1	5/2007	Stad et al.
				2007/0129622	A1	6/2007	Bourget et al.
				2007/0129643	A1	6/2007	Kwok et al.

(56)

References Cited

U.S. PATENT DOCUMENTS

2007/0129769 A1 6/2007 Bourget et al.
 2007/0142715 A1 6/2007 Banet et al.
 2007/0142732 A1 6/2007 Brockway et al.
 2007/0149282 A1 6/2007 Lu et al.
 2007/0150008 A1 6/2007 Jones et al.
 2007/0150009 A1 6/2007 Kveen et al.
 2007/0150029 A1 6/2007 Bourget et al.
 2007/0162089 A1 7/2007 Mosesov
 2007/0167753 A1 7/2007 Van Wyk et al.
 2007/0167848 A1 7/2007 Kuo et al.
 2007/0167849 A1 7/2007 Zhang et al.
 2007/0167850 A1 7/2007 Russell et al.
 2007/0172424 A1 7/2007 Roser
 2007/0173705 A1 7/2007 Teller et al.
 2007/0180047 A1 8/2007 Dong et al.
 2007/0180140 A1 8/2007 Welch et al.
 2007/0191723 A1 8/2007 Prystowsky et al.
 2007/0207858 A1 9/2007 Breving
 2007/0208233 A1 9/2007 Kovacs
 2007/0208235 A1 9/2007 Besson et al.
 2007/0208262 A1 9/2007 Kovacs
 2007/0232867 A1 10/2007 Hansmann
 2007/0244403 A1* 10/2007 Natarajan et al. 600/509
 2007/0249946 A1 10/2007 Kumar et al.
 2007/0250121 A1 10/2007 Miesel et al.
 2007/0255120 A1 11/2007 Rosnov
 2007/0255153 A1 11/2007 Kumar et al.
 2007/0255184 A1 11/2007 Shennib
 2007/0255531 A1 11/2007 Drew
 2007/0260133 A1 11/2007 Meyer
 2007/0260155 A1 11/2007 Rapoport et al.
 2007/0260289 A1 11/2007 Giftakis et al.
 2007/0273504 A1 11/2007 Tran
 2007/0276273 A1 11/2007 Watson, Jr
 2007/0282173 A1 12/2007 Wang et al.
 2007/0299325 A1 12/2007 Farrell et al.
 2008/0004499 A1 1/2008 Davis
 2008/0004904 A1 1/2008 Tran
 2008/0021336 A1* 1/2008 Dobak, III 600/508
 2008/0024293 A1 1/2008 Stylos
 2008/0024294 A1 1/2008 Mazar
 2008/0033260 A1* 2/2008 Sheppard et al. 600/301
 2008/0039700 A1 2/2008 Drinan et al.
 2008/0058614 A1 3/2008 Banet et al.
 2008/0058656 A1* 3/2008 Costello et al. 600/508
 2008/0059239 A1 3/2008 Gerst et al.
 2008/0091089 A1 4/2008 Guillory et al.
 2008/0114220 A1 5/2008 Banet et al.
 2008/0120784 A1 5/2008 Warner et al.
 2008/0139934 A1 6/2008 McMorrow et al.
 2008/0146892 A1 6/2008 LeBoeuf et al.
 2008/0167538 A1 7/2008 Teller et al.
 2008/0171918 A1 7/2008 Teller et al.
 2008/0171922 A1 7/2008 Teller et al.
 2008/0171929 A1 7/2008 Katims
 2008/0183052 A1 7/2008 Teller et al.
 2008/0200774 A1 8/2008 Luo
 2008/0214903 A1 9/2008 Orbach
 2008/0220865 A1 9/2008 Hsu
 2008/0221399 A1 9/2008 Zhou et al.
 2008/0221402 A1 9/2008 Despotis
 2008/0224852 A1 9/2008 Dicks et al.
 2008/0228084 A1 9/2008 Bedard et al.
 2008/0275465 A1 11/2008 Paul et al.
 2008/0287751 A1 11/2008 Stivoric et al.
 2008/0287752 A1 11/2008 Stroetz et al.
 2008/0293491 A1 11/2008 Wu et al.
 2008/0294019 A1 11/2008 Tran
 2008/0294020 A1 11/2008 Sapounas
 2008/0318681 A1 12/2008 Rofougaran et al.
 2008/0319279 A1 12/2008 Ramsay et al.
 2008/0319282 A1 12/2008 Tran
 2008/0319290 A1 12/2008 Mao et al.
 2009/0005016 A1 1/2009 Eng et al.
 2009/0018410 A1 1/2009 Coene et al.

2009/0018456 A1 1/2009 Hung
 2009/0048526 A1 2/2009 Aarts
 2009/0054737 A1 2/2009 Magar et al.
 2009/0062670 A1 3/2009 Sterling et al.
 2009/0073991 A1 3/2009 Landrum et al.
 2009/0076336 A1 3/2009 Mazar et al.
 2009/0076340 A1 3/2009 Libbus et al.
 2009/0076341 A1 3/2009 James et al.
 2009/0076342 A1 3/2009 Amurthur et al.
 2009/0076343 A1 3/2009 James et al.
 2009/0076344 A1 3/2009 Libbus et al.
 2009/0076345 A1 3/2009 Manicka et al.
 2009/0076346 A1 3/2009 James et al.
 2009/0076348 A1 3/2009 Manicka et al.
 2009/0076349 A1 3/2009 Libbus et al.
 2009/0076350 A1 3/2009 Bly et al.
 2009/0076363 A1 3/2009 Bly et al.
 2009/0076364 A1 3/2009 Libbus et al.
 2009/0076397 A1 3/2009 Libbus et al.
 2009/0076401 A1 3/2009 Mazar et al.
 2009/0076405 A1 3/2009 Amurthur et al.
 2009/0076410 A1 3/2009 Libbus et al.
 2009/0076559 A1 3/2009 Libbus et al.
 2009/0177145 A1* 7/2009 Ohlander et al. 604/66
 2009/0182204 A1 7/2009 Semler et al.
 2009/0234410 A1 9/2009 Libbus et al.
 2009/0292194 A1 11/2009 Libbus et al.
 2009/0306633 A1* 12/2009 Trovato et al. 604/891.1
 2010/0056881 A1 3/2010 Libbus et al.
 2010/0191310 A1 7/2010 Bly et al.
 2011/0144470 A1 6/2011 Mazar et al.
 2011/0245711 A1 10/2011 Katra et al.
 2011/0270049 A1* 11/2011 Katra et al. 600/301

FOREIGN PATENT DOCUMENTS

EP 1579801 A1 9/2005
 JP 2005-521448 7/2005
 WO WO 00/79255 12/2000
 WO WO 01/89362 A2 11/2001
 WO WO 02/092101 11/2002
 WO WO 03/082080 10/2003
 WO WO 2005/051164 6/2005
 WO WO 2005/104930 11/2005
 WO WO 2006/008745 1/2006
 WO WO 2006/102476 9/2006
 WO WO 2006/111878 A1 11/2006
 WO WO 2007/041783 4/2007
 WO WO 2007/106455 A2 9/2007
 WO 2009/116906 A1 9/2009

OTHER PUBLICATIONS

Naylor, M. et al., Comprehensive discharge planning for the hospitalized elderly: a randomized clinical trial, *Annals of Internal Medicine*, 120(12):999-1006, 1994, Jun. 15, 1994.
 O'Connell, J.B. et al., Economic impact of heart failure in the United States: time for a different approach, *J. Heart Lung Transpl.* 13:S107-112, 1994.
 Rich, M.W. et al., A multidisciplinary intervention to prevent the readmission of elderly patients with congestive heart failure, *New Engl. J. Med.*, 333(18):1190-95, Nov. 2, 1995.
 U.S. Appl. No. 60/972,537, filed Sep. 14, 2008, Manicka et al.
 U.S. Appl. No. 61/055,666, filed May 23, 2008, Manicka et al.
 U.S. Appl. No. 61/084,567, filed Jul. 29, 2008, Bly.
 AD5934: 250 kSPS 12-Bit Impedance Converter Network Analyzer, Analog Devices, retrieved from the Internet: <<http://www.analog.com/static/imported-files/data_sheets/AD5934.pdf>>, 40 pages.
 Something in the way he moves, *The Economist*, 2007, retrieved from the Internet: <<http://www.economist.com/science/printerFriendly.cfm?story_id=9861412>>.
 Abraham, "New approaches to monitoring heart failure before symptoms appear," *Rev Cardiovasc Med.* 2006 ;7 Suppl 1 :33-41.
 Adams, Jr. "Guiding heart failure care by invasive hemodynamic measurements: possible or useful?," *Journal of Cardiac Failure* 2002; 8(2):71-73.

(56)

References Cited

OTHER PUBLICATIONS

- Adamson et al., "Continuous autonomic assessment in patients with symptomatic heart failure: prognostic value of heart rate variability measured by an implanted cardiac resynchronization device," *Circulation*. 2004;110:2389-2394.
- Adamson et al., "Ongoing right ventricular hemodynamics in heart failure," *J Am Coll Cardiol*, 2003; 41:565-57.
- Adamson, "Integrating device monitoring into the infrastructure and workflow of routine practice," *Rev Cardiovasc Med*. 2006 ;7 Suppl 1:42-6.
- Adhere [presentation], "Insights from the Adhere Registry: Data from over 100,000 patient cases," 70 pages total.
- Advanced White Sheet, "Health Information Technology: Improving Patient Safety and Quality of Care," Jun. 2005, 23 pages.
- Aghababian, "Acutely decompensated heart failure: opportunities to improve care and outcomes in the emergency department," *Rev Cardiovasc Med*. 2002;3 Suppl 4:S3-9.
- Albert, "Bioimpedance to prevent heart failure hospitalization," *Curr Heart Fail Rep*. Sep. 2006;3(3):136-42.
- American Heart Association, "Heart Disease and Stroke Statistics-2006 Update," 2006, 43 pages.
- American Heart Association, "Heart Disease and Stroke Statistics-2007 Update. A Report From the American Heart Association Statistics Committee and Stroke Statistics Subcommittee," *Circulation* 2007; 115:e69-e171.
- Belalcazar et al., "Monitoring lung edema using the pacemaker pulse and skin electrodes," *Physiol. Meas*. 2005; 26:S153-S163.
- Bennet, "Development of implantable devices for continuous ambulatory monitoring of central hemodynamic values in heart failure patients," *PACE* Jun. 2005; 28:573-584.
- Bourge, "Case studies in advanced monitoring with the chronicle device," *Rev Cardiovasc Med*. 2006 ;7 Suppl 1:S56-61.
- Braunschweig, "Continuous haemodynamic monitoring during withdrawal of diuretics in patients with congestive heart failure," *European Heart Journal* 2002 23(1):59-69.
- Braunschweig, "Dynamic changes in right ventricular pressures during haemodialysis recorded with an implantable haemodynamic monitor," *Nephrol Dial Transplant* 2006; 21:176-183.
- Brennan, "Measuring a Grounded Impedance Profile Using the AD5933," *Analog Devices*, retrieved from the internet <<http://www.analog.com/static/imported-files/application_notes/427095282381510189AN847_0.pdf>>, 12 pages total.
- Buono et al., "The effect of ambient air temperature on whole-body bioelectrical impedance," *Physiol. Meas*. 2004;25:119-123.
- Burkhoff et al., "Heart failure with a normal ejection fraction: Is it really a disorder of diastolic function?" *Circulation* 2003; 107:656-658.
- Burr et al., "Heart rate variability and 24-hour minimum heart rate," *Biological Research for Nursing*, 2006; 7(4):256-267.
- Cardionet, "CardioNet Mobile Cardiac Outpatient Telemetry: Addendum to Patient Education Guide", CardioNet, Inc., 2007, 2 pages.
- Cardionet, "Patient Education Guide", CardioNet, Inc., 2007, 7 pages, Undated.
- Charach et al., "Transthoracic monitoring of the impedance of the right lung in patients with cardiogenic pulmonary edema," *Crit Care Med* Jun. 2001;29(6):1137-1144.
- Charlson et al., "Can disease management target patients most likely to generate high costs? The Impact of Comorbidity," *Journal of General Internal Medicine*, Apr. 2007, 22(4):464-469.
- Chaudhry et al., "Telemonitoring for patients with chronic heart failure: a systematic review," *J Card Fail*. Feb. 2007; 13(1): 56-62.
- Chung et al., "White coat hypertension: Not so benign after all?," *Journal of Human Hypertension* (2003) 17, 807-809.
- Cleland et al., "The EuroHeart Failure survey programme—a survey on the quality of care among patients with heart failure in Europe—Part 1: patient characteristics and diagnosis," *European Heart Journal* 2003 24(5):442-463.
- Cowie et al., "Hospitalization of patients with heart failure. A population-based study," *European Heart Journal* 2002 23(11):877-885.
- Dimri, Chapter 1: Fractals in geophysics and seismology: an introduction, *Fractal Behaviour of the Earth System*, Springer Berlin Heidelberg 2005, pp. 1-22. [Summary and 1st page Only].
- El-Dawlatly et al., "Impedance cardiography: noninvasive assessment of hemodynamics and thoracic fluid content during bariatric surgery," *Obesity Surgery*, May 2005, 15(5):655-658.
- Erdmann, "Editorials: The value of diuretics in chronic heart failure demonstrated by an implanted haemodynamic monitor," *European Heart Journal* 2002 23(1):7-9.
- FDA—Medtronic Inc., *Chronicle 9520B Implantable Hemodynamic Monitor Reference Manual*, 2007, 112 pages.
- FDA Executive Summary Memorandum, prepared for Mar. 1, 2007, meeting of the Circulatory Systems Devices Advisory Panel, P050032 Medtronic, Inc. *Chronicle Implantable Hemodynamic Monitor (IHM) System*, 23 pages. Retrieved from the Internet: <<http://www.fda.gov/ohrms/dockets/ac/07/briefing/2007-4284b1_02.pdf>>.
- FDA Executive Summary, *Medtronic Chronicle Implantable Hemodynamic Monitoring System P050032: Panel Package Sponsor Executive Summary*; vol. 1, section 4: Executive Summary. 12 pages total. Retrieved from the Internet: <<http://www.fda.gov/OHRMS/DOCKETS/AC/07/briefing/2007-4284b1_03.pdf>>.
- FDA—Medtronic Chronicle Implantable Hemodynamic Monitoring System P050032: Panel Package Section 11: *Chronicle IHM Summary of Safety and Effectiveness*, 2007; retrieved from the Internet: <<http://www.fda.gov/OHRMS/DOCKETS/AC/07/briefing/2007-4284b1_04.pdf>>, 77 pages total.
- FDA, Draft questions for Chronicle Advisory Panel Meeting, 3 pages. Retrieved from the Internet: <<http://www.fda.gov/ohrms/dockets/ac/07/questions/2007-4284q1_draft.pdf>>.
- FDA, References for Mar. 1 Circulatory System Devices Panel, 1 page total. Retrieved from the Internet: <<http://www.fda.gov/OHRMS/DOCKETS/AC/07/briefing/2007-4284bib1_01.pdf>>.
- FDA Panel Recommendation, "Chronicle Analysis," Mar. 1, 2007, 14 pages total.
- Fonarow et al., "Risk stratification for in-hospital mortality in acutely decompensated heart failure: classification and regression tree analysis," *JAMA*. Feb. 2, 2005;293(5):572-580.
- Fonarow, "How well are chronic heart failure patients being managed?," *Rev Cardiovasc Med*. 2006;7 Suppl 1:S3-11.
- Fonarow, "Maximizing Heart Failure Care" [Powerpoint Presentation], downloaded from the Internet <<<http://www.medreviews.com/media/MaxHFCore.ppt>>>, 130 pages total.
- Fonarow, "Proactive monitoring and management of the chronic heart failure patient," *Rev Cardiovasc Med*. 2006; 7 Suppl 1:S1-2.
- Fonarow, "The Acute Decompensated Heart Failure National Registry (ADHERE): opportunities to improve care of patients hospitalized with acute decompensated heart failure," *Rev Cardiovasc Med*. 2003;4 Suppl 7:S21-S30.
- Ganion et al., "Intrathoracic impedance to monitor heart failure status: a comparison of two methods in a chronic heart failure dog model," *Congest Heart Fail*. Jul.-Aug. 2005;11(4):177-81, 211.
- Gass et al., "Critical pathways in the management of acute decompensated heart failure: A CME-Accredited monograph," Mount Sinai School of Medicine, 2004, 32 pages total.
- Gheorghide et al., "Congestion is an important diagnostic and therapeutic target in heart failure," *Rev Cardiovasc Med*. 2006 ;7 Suppl 1 :12-24.
- Gilliam, III et al., "Changes in heart rate variability, quality of life, and activity in cardiac resynchronization therapy patients: results of the HF-HRV registry," *Pacing and Clinical Electrophysiology*, Jan. 18, 2007; 30(1): 56-64.
- Gilliam, III et al., "Prognostic value of heart rate variability footprint and standard deviation of average 5-minute intrinsic R-R intervals for mortality in cardiac resynchronization therapy patients.," *J Electrocardiol*. Oct. 2007;40(4):336-42.
- Gniadecka, "Localization of dermal edema in lipodermatosclerosis, lymphedema, and cardiac insufficiency high-frequency ultrasound examination of intradermal echogenicity," *J Am Acad Dermatol*, Jul. 1996; 35(1):37-41.

(56)

References Cited

OTHER PUBLICATIONS

- Goldberg et al., "Randomized trial of a daily electronic home monitoring system in patients with advanced heart failure: The Weight Monitoring in Heart Failure (WHARF) Trial," *American Heart Journal*, Oct. 2003; 416(4):705-712.
- Grap et al., "Actigraphy in the Critically III: Correlation With Activity, Agitation, and Sedation," *American Journal of Critical Care*. 2005;14: 52-60.
- Gudivaka et al., "Single—and multifrequency models for bioelectrical impedance analysis of body water compartments," *J Appl Physiol*, 1999;87(3):1087-1096.
- Guyton et al., UNIT V: The Body Fluids and Kidneys, Chapter 25: The Body Fluid Compartments: Extracellular and Intracellular Fluids; Interstitial Fluid and Edema, *Guyton & Hall Textbook of Medical Physiology* 11th Edition, Saunders 2005; pp. 291-306.
- Hadase et al., "Very low frequency power of heart rate variability is a powerful predictor of clinical prognosis in patients with congestive heart failure," *Circ J* 2004; 68(4):343-347.
- Hallstrom et al., "Structural relationships between measures based on heart beat intervals: potential for improved risk assessment," *IEEE Biomedical Engineering* 2004, 51(8):1414-1420.
- HFSA 2006 Comprehensive Heart Failure Practice Guideline—Executive Summary: HFSA 2006 Comprehensive Heart Failure Practice Guideline, *Journal of Cardiac Failure* 2006;12(1):10-e38.
- HFSA 2006 Comprehensive Heart Failure Practice Guideline—Section 12: Evaluation and Management of Patients With Acute Decompensated Heart Failure, *Journal of Cardiac Failure* 2006;12(1):e86-e103.
- HFSA 2006 Comprehensive Heart Failure Practice Guideline—Section 2: Conceptualization and Working Definition of Heart Failure, *Journal of Cardiac Failure* 2006;12(1):e10-e11.
- HFSA 2006 Comprehensive Heart Failure Practice Guideline—Section 3: Prevention of Ventricular Remodeling Cardiac Dysfunction, and Heart Failure Overview, *Journal of Cardiac Failure* 2006;12(1):e12-e15.
- HFSA 2006 Comprehensive Heart Failure Practice Guideline—Section 4: Evaluation of Patients for Ventricular Dysfunction and Heart Failure, *Journal of Cardiac Failure* 2006;12(1):e16-e25.
- HFSA 2006 Comprehensive Heart Failure Practice Guideline—Section 8: Disease Management in Heart Failure Education and Counseling, *Journal of Cardiac Failure* 2006;12(1):e58-e68.
- Hunt et al., "ACC/AHA 2005 Guideline Update for the Diagnosis and Management of Chronic Heart Failure in the Adult: A Report of the American College of Cardiology/American Heart Association Task Force on Practice Guidelines (Writing Committee to Update the 2001 Guidelines for the Evaluation and Management of Heart Failure): Developed in Collaboration With the American College of Chest Physicians and the International Society for Heart and Lung Transplantation: Endorsed by the Heart Rhythm Society," *Circulation*. 2005;112:e154-e235.
- Hunt et al., ACC/AHA Guidelines for the Evaluation and Management of Chronic Heart Failure in the Adult: Executive Summary a Report of the American College of Cardiology/American Heart Association Task Force on Practice Guidelines (Committee to Revise the 1995 Guidelines for the Evaluation and Management of Heart Failure), *Circulation*. 2001;104:2996-3007.
- Imhoff et al., "Noninvasive whole-body electrical bioimpedance cardiac output and invasive thermodilution cardiac output in high-risk surgical patients," *Critical Care Medicine* 2000; 28(8):2812-2818.
- Jaeger et al., "Evidence for Increased Intrathoracic Fluid Volume in Man at High Altitude," *J Appl Physiol* 1979; 47(6): 670-676.
- Jerant et al., "Reducing the cost of frequent hospital admissions for congestive heart failure: a randomized trial of a home telecare intervention," *Medical Care* 2001, 39(11):1234-1245.
- Jaio et al., "Variance fractal dimension analysis of seismic refraction signals," WESCANEX 97: Communications, Power and Computing. IEEE Conference Proceedings., May 22-23, 1997, pp. 163-167 [Abstract Only].
- Kasper et al., "A randomized trial of the efficacy of multidisciplinary care in heart failure outpatients at high risk of hospital readmission," *J Am Coll Cardiol*, 2002; 39:471-480.
- Kaukinen, "Cardiac output measurement after coronary artery bypass grafting using bolus thermodilution, continuous thermodilution, and whole-body impedance cardiography," *Journal of Cardiothoracic and Vascular Anesthesia* 2003; 17(2):199-203.
- Kawaguchi et al., "Combined ventricular systolic and arterial stiffening in patients with heart failure and preserved ejection fraction: implications for systolic and diastolic reserve limitations," *Circulation*. 2003;107:714-720.
- Kawasaki et al., "Heart rate turbulence and clinical prognosis in hypertrophic cardiomyopathy and myocardial infarction," *Circ J*. Jul. 2003;67(7):601-604.
- Kearney et al., "Predicting death due to progressive heart failure in patients with mild-to moderate chronic heart failure," *J Am Coll Cardiol*, 2002; 40(10):1801-1808.
- Kitzman et al., "Pathophysiological characterization of isolated diastolic heart failure in comparison to systolic heart failure," *JAMA* Nov. 2002; 288(17):2144-2150.
- Kööbi et al., "Non-invasive measurement of cardiac output : whole-body impedance cardiography in simultaneous comparison with thermodilution and direct oxygen Fick methods," *Intensive Care Medicine* 1997; 23(11):1132-1137.
- Koyama et al., "Evaluation of heart-rate turbulence as a new prognostic marker in patients with chronic heart failure," *Circ J* 2002; 66(10):902-907.
- Krumholz et al., "Predictors of readmission among elderly survivors of admission with heart failure," *American Heart Journal* 2000; 139(1):72-77.
- Kyle et al., "Bioelectrical Impedance Analysis—part I: review of principles and methods," *Clin Nutr*. Oct. 2004;23(5):1226-1243.
- Kyle et al., "Bioelectrical Impedance Analysis—part II: utilization in clinical practice," *Clin Nutr*. Oct. 2004;23(5):1430-1453.
- Lee et al., "Predicting mortality among patients hospitalized for heart failure: derivation and validation of a clinical model," *JAMA* 2003;290(19):2581-2587.
- Leier "The Physical Examination in Heart Failure—Part I," *Congest Heart Fail*. Jan. - Feb 2007;13(1):41-47.
- LifeShirt® Model 200 Directions for Use*, "Introduction", VivoMetrics, Inc. 9 pages total.
- Liu et al., "Fractal analysis with applications to seismological pattern recognition of underground nuclear explosions," *Singal Processing*, Sep. 2000, 80(9):1849-1861. [Abstract Only].
- Lozano-Nieto, "Impedance ratio in bioelectrical impedance measurements for body fluid shift determination," *Proceedings of the IEEE 24th Annual Northeast Bioengineering Conference*, Apr. 9-10, 1998, pp. 24-25.
- Lucreziotti et al., "Five-minute recording of heart rate variability in severe chronic heart failure : Correlates with right ventricular function and prognostic implications," *American Heart Journal* 2000; 139(6):1088-1095.
- Lüthje et al., "Detection of heart failure decompensation using intrathoracic impedance monitoring by a triple-chamber implantable defibrillator," *Heart Rhythm* Sep. 2005;2(9):997-999.
- Magalski et al., "Continuous ambulatory right heart pressure measurements with an implantable hemodynamic monitor: a multicenter, 12-Month Follow-up Study of Patients With Chronic Heart Failure," *J Card Fail* 2002, 8(2):63-70.
- Mahlberg et al., "Actigraphy in agitated patients with dementia: Monitoring treatment outcomes," *Zeitschrift für Gerontologie und Geriatrie*, Jun. 2007; 40(3)178-184. [Abstract Only].
- Matthie et al., "Analytic assessment of the various bioimpedance methods used to estimate body water," *Appl Physiol* 1998; 84(5):1801-1816.
- Matthie, "Second generation mixture theory equation for estimating intracellular water using bioimpedance spectroscopy," *J Appl Physiol* 2005; 99:780-781.
- McMurray et al., "Heart Failure: Epidemiology, Aetiology, and Prognosis of Heart Failure," *Heart* 2000;83:596-602.
- Moser et al., "Improving outcomes in heart failure: its not unusual beyond usual Care," *Circulation*. 2002;105:2810-2812.

(56)

References Cited

OTHER PUBLICATIONS

- Nagels et al., "Actigraphic measurement of agitated behaviour in dementia," *International journal of geriatric psychiatry*, 2009; 21(4):388-393. [Abstract Only].
- Nakamura et al., "Universal scaling law in human behavioral organization," *Physical Review Letters*, Sep. 28, 2007; 99(13):138103 (4 pages).
- Nakaya, "Fractal properties of seismicity in regions affected by large, shallow earthquakes in western Japan: Implications for fault formation processes based on a binary fractal fracture network model," *Journal of geophysical research*, Jan. 2005; 11(B1):B01310.1-B01310.15. [Abstract Only].
- Naylor et al., "Comprehensive discharge planning for the hospitalized elderly: a randomized clinical trial," *Amer. College Physicians* 1994; 120(12):999-1006.
- Nesiritide (NATRECOR), [Presentation] Acutely Decompensated Congestive Heart Failure: Burden of Disease, downloaded from the Internet: <<<http://www.huntsvillehospital.org/foundation/events/cardiologypupdate/CHF.ppt>>>, 39 pages.
- Nieminen et al., "EuroHeart Failure Survey II (EHFS II): a survey on hospitalized acute heart failure patients: description of population," *European Heart Journal* 2006; 27(22):2725-2736.
- Nijssen et al., "The potential value of three-dimensional accelerometry for detection of motor seizures in severe epilepsy," *Epilepsy Behav.* Aug. 2005;7(1):74-84.
- Noble et al., "Diuretic induced change in lung water assessed by electrical impedance tomography," *Physiol. Meas.* 2000; 21(1):155-163.
- Noble et al., "Monitoring patients with left ventricular failure by electrical impedance tomography," *Eur J Heart Fail.* Dec. 1999;1(4):379-84.
- Ohlsson et al., "Central hemodynamic responses during serial exercise tests in heart failure patients using implantable hemodynamic monitors," *Eur J Heart Fail.* Jun. 2003;5(3):253-259.
- Ohlsson et al., "Continuous ambulatory monitoring of absolute right ventricular pressure and mixed venous oxygen saturation in patients with heart failure using an implantable haemodynamic monitor," *European Heart Journal* 2001 22(11):942-954.
- Packer et al., "Utility of impedance cardiography for the identification of short-term risk of clinical decompensation in stable patients with chronic heart failure," *J Am Coll Cardiol*, 2006; 47(11):2245-2252.
- Palatini et al., "Predictive value of clinic and ambulatory heart rate for mortality in elderly subjects with systolic hypertension" *Arch Intern Med.* 2002;162:2313-2321.
- Piirra et al., "Crackles in patients with fibrosing alveolitis bronchiectasis, COPD, and Heart Failure," *Chest* May 1991; 99(5):1076-1083.
- Pocock et al., "Predictors of mortality in patients with chronic heart failure," *Eur Heart J* 2006; (27): 65-75.
- Poole-Wilson, "Importance of control of fluid volumes in heart failure," *European Heart Journal* 2000; 22(11):893-894.
- Raj et al., Letter Regarding Article by Adamson et al., "Continuous Autonomic Assessment in Patients With Symptomatic Heart Failure: Prognostic Value of Heart Rate Variability Measured by an Implanted Cardiac Resynchronization Device", *Circulation* 2005;112:e37-e38.
- Ramirez et al., "Prognostic value of hemodynamic findings from impedance cardiography in hypertensive stroke," *AJH* 2005; 18(20):65-72.
- Roglieri et al., "Disease management interventions to improve outcomes in congestive heart failure," *Am J Manag Care.* Dec. 1997;3(12):1831-1839.
- Sahalos et al., "The electrical impedance of the human thorax as a guide in evaluation of intrathoracic fluid volume," *Phys. Med. Biol.* 1986; 31:425-439.
- Saxon et al., "Remote active monitoring in patients with heart failure (rapid-rf): design and rationale," *Journal of Cardiac Failure* 2007; 13(4):241-246.
- Scharf et al., "Direct digital capture of pulse oximetry waveforms," *Proceedings of the Twelfth Southern Biomedical Engineering Conference*, 1993., pp. 230-232.
- Shabetai, "Monitoring heart failure hemodynamics with an implanted device: its potential to improve outcome," *J Am Coll Cardiol*, 2003; 41:572-573.
- Small, "Integrating monitoring into the Infrastructure and Workflow of Routine Practice: OptiVol," *Rev Cardiovasc Med.* 2006 ;7 Suppl 1: S47-S55.
- Smith et al., "Outcomes in heart failure patients with preserved ejection fraction: mortality, readmission, and functional decline," *J Am Coll Cardiol*, 2003; 41:1510-1518.
- Someren, "Actigraphic monitoring of movement and rest-activity rhythms in aging, Alzheimer's disease, and Parkinson's disease," *IEEE Transactions on Rehabilitation Engineering*, Dec. 1997; 5(4):394-398. [Abstract Only].
- Starling, "Improving care of chronic heart failure: advances from drugs to devices," *Cleveland Clinic Journal of Medicine* Feb. 2003; 70(2):141-146.
- Steijaert et al., "The use of multi-frequency impedance to determine total body water and extracellular water in obese and lean female individuals," *International Journal of Obesity* Oct. 1997; 21(10):930-934.
- Stewart et al., "Effects of a home-based intervention among patients with congestive heart failure discharged from acute hospital care," *Arch Intern Med.* 1998;158:1067-1072.
- Stewart et al., "Effects of a multidisciplinary, home-based intervention on planned readmissions and survival among patients with chronic congestive heart failure: a randomised controlled study," *The Lancet* Sep. 1999 354(9184):1077-1083.
- Stewart et al., "Home-based intervention in congestive heart failure: long-term implications on readmission and survival," *Circulation.* 2002;105:2861-2866.
- Stewart et al., "Prolonged beneficial effects of a home-based intervention on unplanned readmissions and mortality among patients with congestive heart failure," *Arch Intern Med.* 1999;159:257-261.
- Stewart et al., "Trends in Hospitalization for Heart Failure in Scotland, 1990-1996. An Epidemic that has Reached Its Peak?," *European Heart Journal* 2001 22(3):209-217.
- Swedberg et al., "Guidelines for the diagnosis and treatment of chronic heart failure: executive summary (update 2005): The Task Force for the Diagnosis and Treatment of Chronic Heart Failure of the European Society of Cardiology," *Eur Heart J.* Jun. 2005; 26(11):1115-1140.
- Tang, "Case studies in advanced monitoring: OptiVol," *Rev Cardiovasc Med.* 2006;7 Suppl 1:S62-S66.
- The ESCAPE Investigators and ESCAPE Study Coordinators, "Evaluation Study of Congestive Heart Failure and Pulmonary Artery Catheterization Effectiveness," *JAMA* 2005;294:1625-1633.
- Tosi et al., "Seismic signal detection by fractal dimension analysis," *Bulletin of the Seismological Society of America*; Aug. 1999; 89(4):970-977. [Abstract Only].
- Van De Water et al., "Monitoring the chest with impedance," *Chest.* 1973;64:597-603.
- Vasan et al., "Congestive heart failure in subjects with normal versus reduced left ventricular ejection fraction," *J Am Coll Cardiol*, 1999; 33:1948-1955.
- Verdecchia et al., "Adverse prognostic value of a blunted circadian rhythm of heart rate in essential hypertension," *Journal of Hypertension* 1998; 16(9):1335-1343.
- Verdecchia et al., "Ambulatory pulse pressure: a potent predictor of total cardiovascular risk in hypertension," *Hypertension.* 1998;32:983-988.
- Vollmann et al., "Clinical utility of intrathoracic impedance monitoring to alert patients with an implanted device of deteriorating chronic heart failure," *European Heart Journal Advance Access published on Feb. 19, 2007*, downloaded from the Internet:<<<http://eurheartj.oxfordjournals.org/cgi/content/full/ehl506v1>>>, 6 pages total.
- Vuksanovic et al., "Effect of posture on heart rate variability spectral measures in children and young adults with heart disease," *International Journal of Cardiology* 2005;101(2): 273-278.

(56)

References Cited

OTHER PUBLICATIONS

Wang et al., "Feasibility of using an implantable system to measure thoracic congestion in an ambulatory chronic heart failure canine model," *PACE* 2005;28(5):404-411.

Wickemeyer et al., #197—"Association between atrial and ventricular tachyarrhythmias, intrathoracic impedance and heart failure decompensation in CRT-D Patients," *Journal of Cardiac Failure* 2007; 13 (6) Suppl.; S131-132.

Williams et al., "How do different indicators of cardiac pump function impact upon the long-term prognosis of patients with chronic heart failure," *American Heart Journal*, 150(5):983.e1-983.e6.

Wonisch et al., "Continuous haemodynamic monitoring during exercise in patients with pulmonary hypertension," *Int J Cardiol*. Jun. 8, 2005;101(3):415-420.

Wynne et al., "Impedance cardiography: a potential monitor for hemodialysis," *Journal of Surgical Research* 2006, 133(1):55-60.

Yancy "Current approaches to monitoring and management of heart failure," *Rev Cardiovasc Med* 2006; 7 Suppl 1:S25-32.

Ypenburg et al., "Intrathoracic Impedance Monitoring to Predict Decompensated Heart Failure," *Am J Cardiol* 2007, 99(4):554-557.

Yu et al., "Intrathoracic Impedance Monitoring in Patients With Heart Failure: Correlation With Fluid Status and Feasibility of Early Warning Preceding Hospitalization," *Circulation*. 2005;112:841-848.

Zannad et al., "Incidence, clinical and etiologic features, and outcomes of advanced chronic heart failure: The EPICAL Study," *J Am Coll Cardiol*, 1999; 33(3):734-742.

Zile, "Heart failure with preserved ejection fraction: is this diastolic heart failure?" *J Am Coll Cardiol*, 2003; 41(9):1519-1522.

U.S. Appl. No. 60/006,600, filed Nov. 13, 1995; inventor: Terry E. Flach.

U.S. Appl. No. 60/972,316, filed Sep. 12, 2008; inventor: Imad Libbus et al.

U.S. Appl. No. 60/972,329, filed Sep. 14, 2007; inventor: Yatheendhar Manicka et al.

U.S. Appl. No. 60/972,333, filed Sep. 14, 2007; inventor: Mark Bly et al.

U.S. Appl. No. 60/972,336, filed Sep. 14, 2007; inventor: James Kristofer et al.

U.S. Appl. No. 60/972,340, filed Sep. 14, 2007; inventor: James Kristofer et al.

U.S. Appl. No. 60/972,343, filed Sep. 14, 2007; inventor: James Kristofer et al.

U.S. Appl. No. 60/972,354, filed Sep. 14, 2007; inventor: Scott Thomas Mazar et al.

U.S. Appl. No. 60/972,359, filed Sep. 14, 2007; inventor: Badri Amurthur et al.

U.S. Appl. No. 60/972,363, filed Sep. 14, 2007; inventor: Badri Amurthur et al.

U.S. Appl. No. 60/972,512, filed Sep. 14, 2007; inventor: Imad Libbus et al.

U.S. Appl. No. 60/972,581, filed Sep. 14, 2007; inventor: Imad Libbus et al.

U.S. Appl. No. 60/972,616, filed Sep. 14, 2007; inventor: Imad Libbus et al.

U.S. Appl. No. 60/972,629, filed Sep. 14, 2007; inventor: Mark Bly et al.

U.S. Appl. No. 61/035,970, filed Mar. 12, 2008; inventor: Imad Libbus et al.

U.S. Appl. No. 61/046,196, filed Apr. 18, 2008; inventor: Scott T. Mazar.

U.S. Appl. No. 61/047,875, filed Apr. 25, 2008; inventor: Imad Libbus et al.

U.S. Appl. No. 61/055,645, filed May 23, 2008; inventor: Mark Bly et al.

U.S. Appl. No. 61/055,656, filed May 23, 2008; inventor: Imad Libbus et al.

U.S. Appl. No. 61/055,662, filed May 23, 2008; inventor: Imad Libbus et al.

U.S. Appl. No. 61/079,746, filed Jul. 10, 2008; inventor: Brett Landrum.

"Acute Decompensated Heart Failure" —Wikipedia Entry, downloaded from: <http://en.wikipedia.org/wiki/Acute_decompensated_heart_failure>, entry page created in 2008, 6 pages total.

"Heart Failure" —Wikipedia Entry, downloaded from the Internet: <http://en.wikipedia.org/wiki/Heart_failure>, entry page created in 2003, 17 pages total.

"Corporation, 3M Surgical Tapes—Choose the Correct Tape" quicksheet (2004).

Cooley, "The Parameters of Transthoracic Electrical Conduction," *Annals of the New York Academy of Sciences*, 1970; 170(2):702-713.

EM Microelectronic—Marin SA, "Plastic Flexible LCD," [product brochure]; retrieved from the Internet: <<<http://www.em-microelectronic.com/Line.asp?idLine=48>>>, copyright 2009, 2 pages total.

HRV Enterprises, LLC, "Heart Rate Variability Seminars," downloaded from the Internet: <<<http://hrventerprise.com/>>> on Apr. 24, 2008, 3 pages total.

HRV Enterprises, LLC, "LoggerPro HRV Biosignal Analysis," downloaded from the Internet: <<<http://hrventerprise.com/products.html>>> on Apr. 24, 2008, 3 pages total.

* cited by examiner

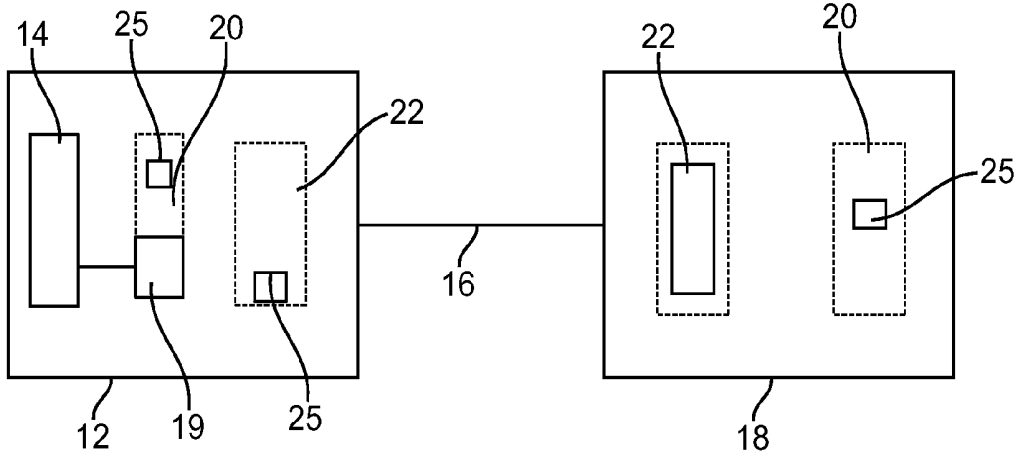

FIG. 1

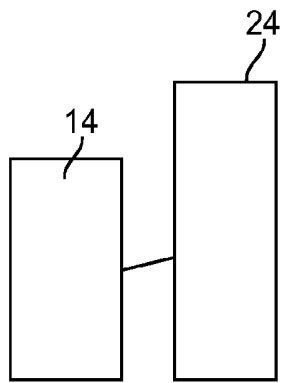

FIG. 4

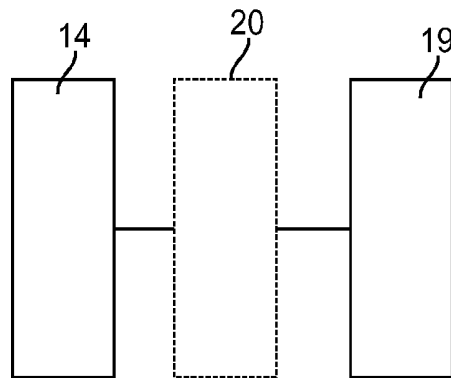

FIG. 3

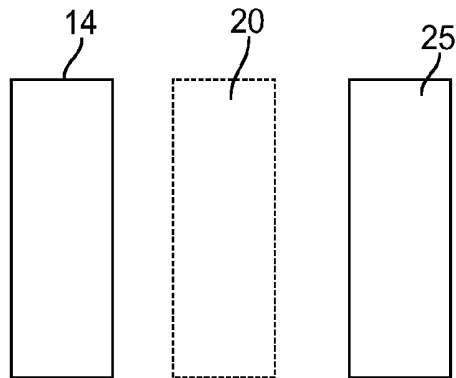

FIG. 5

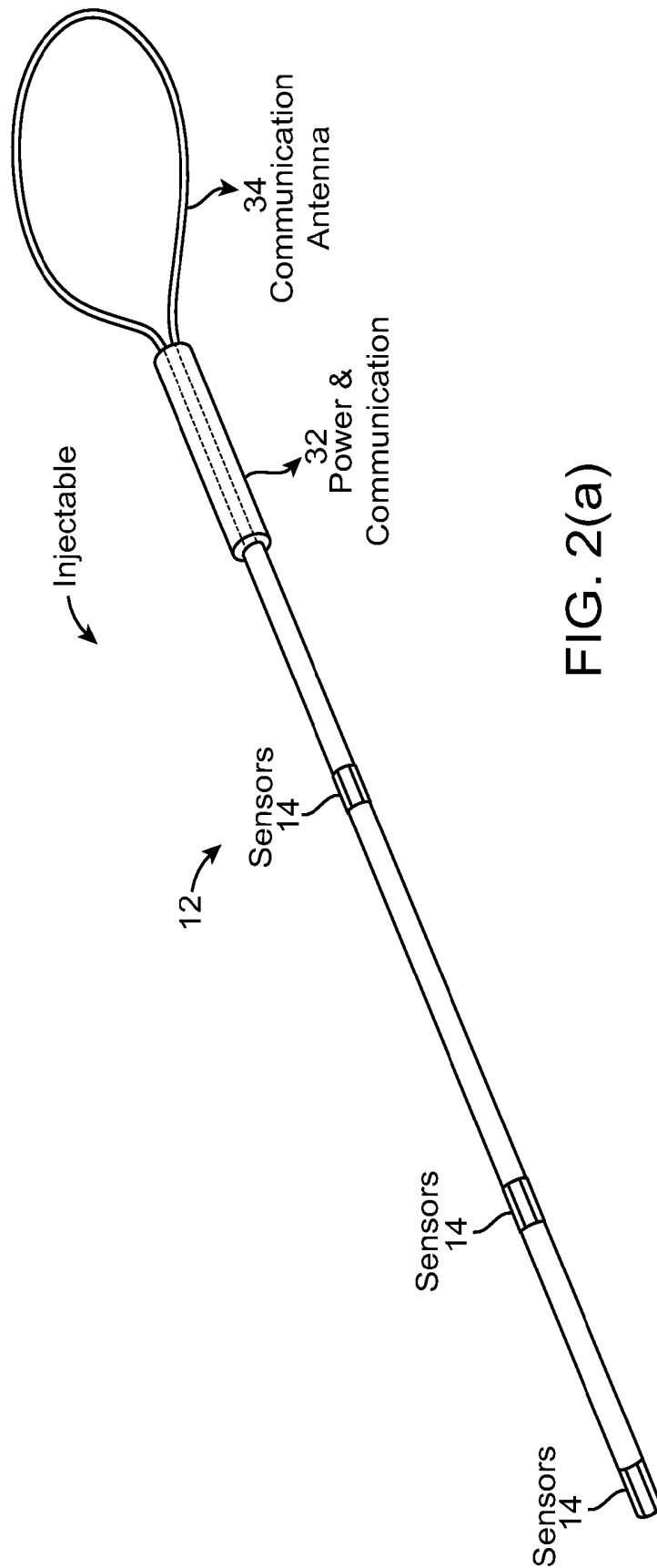

FIG. 2(a)

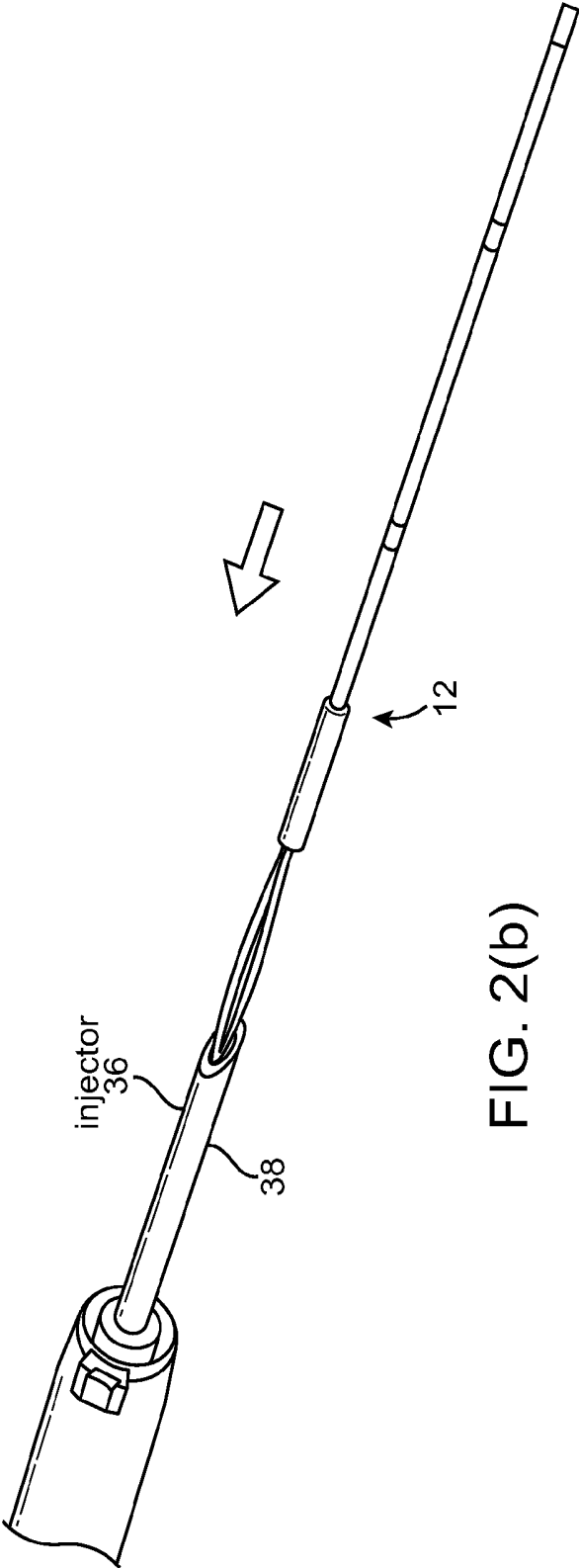

FIG. 2(b)

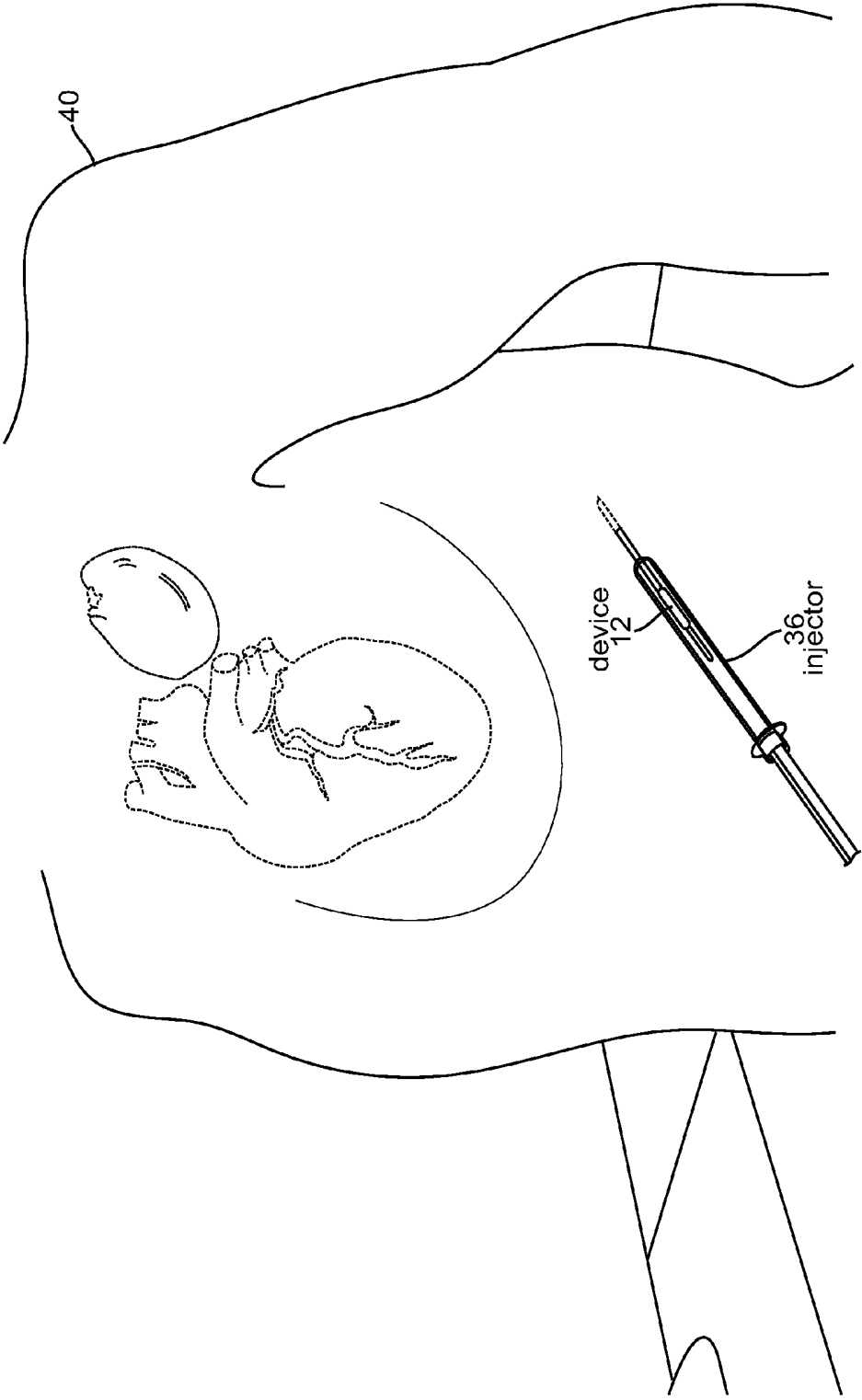

FIG. 2(c)

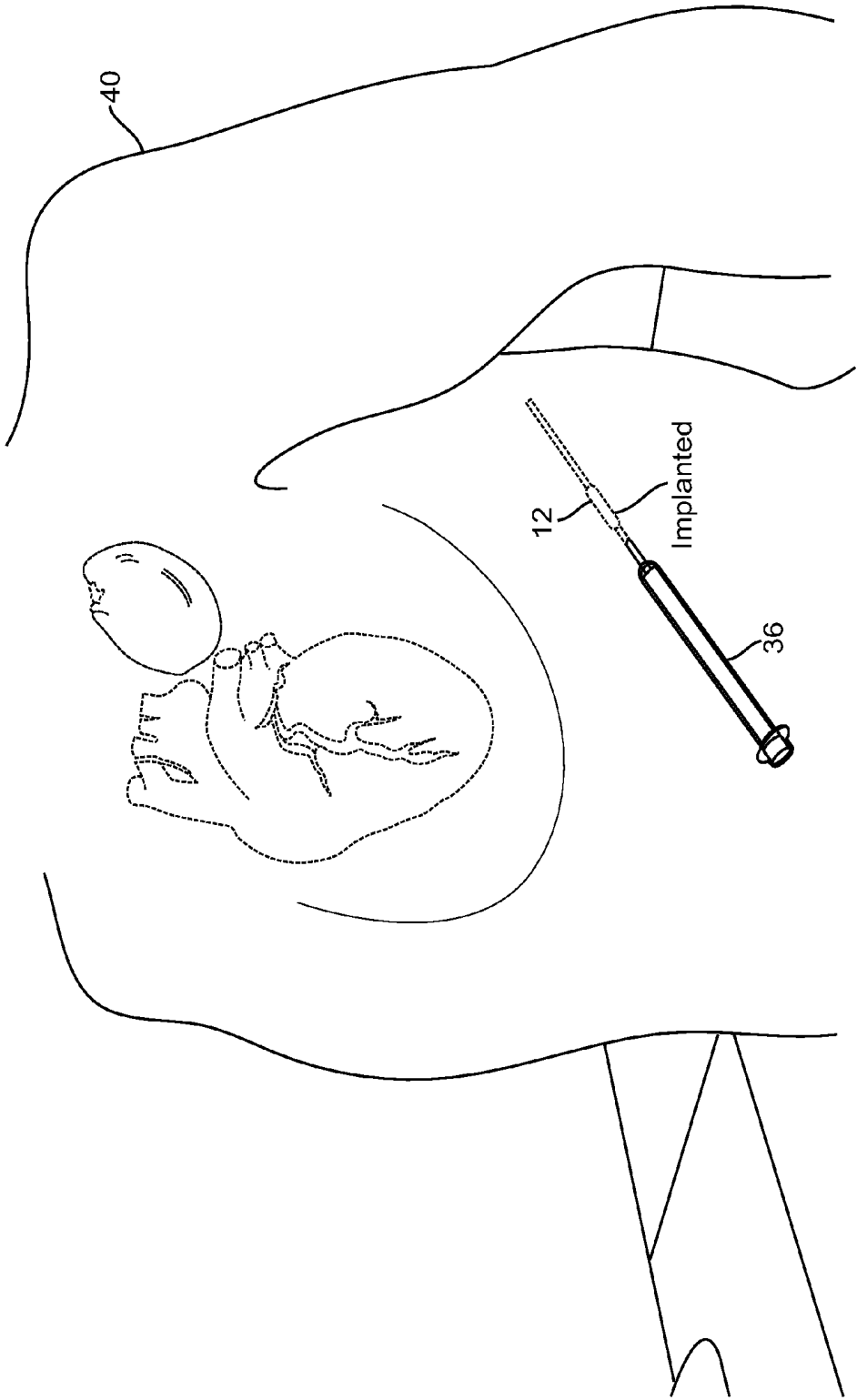

FIG. 2(d)

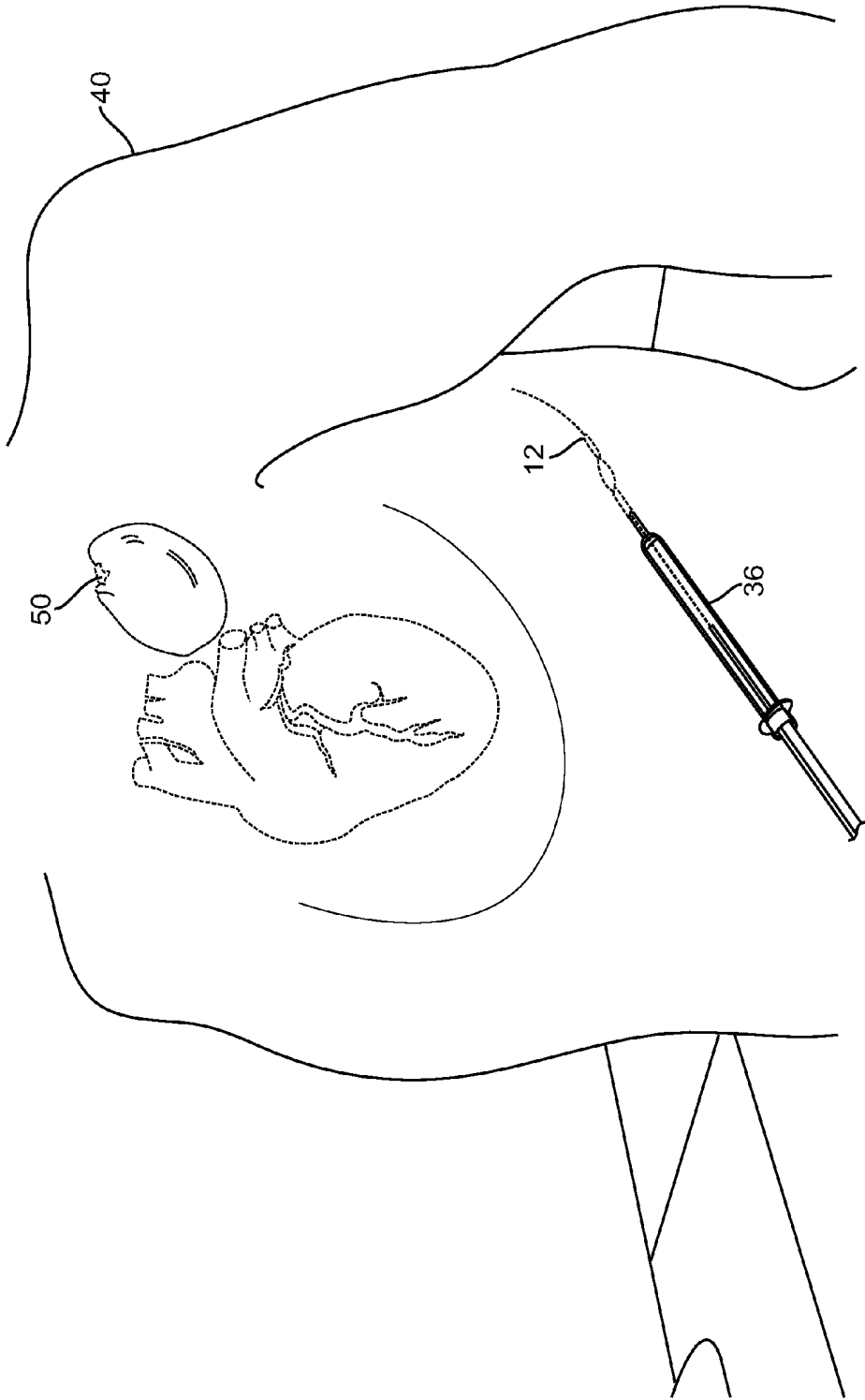

FIG. 2(e)

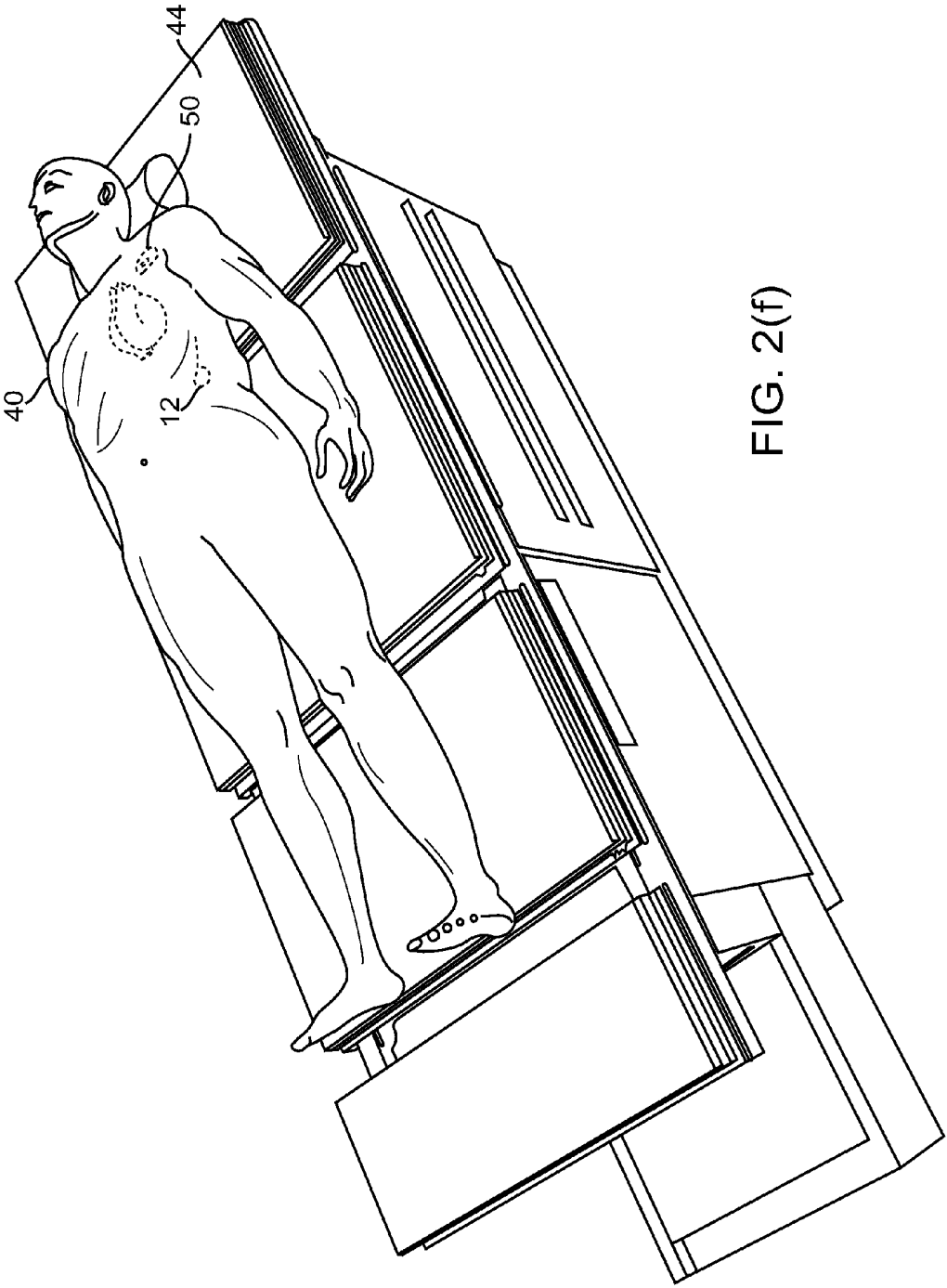

FIG. 2(f)

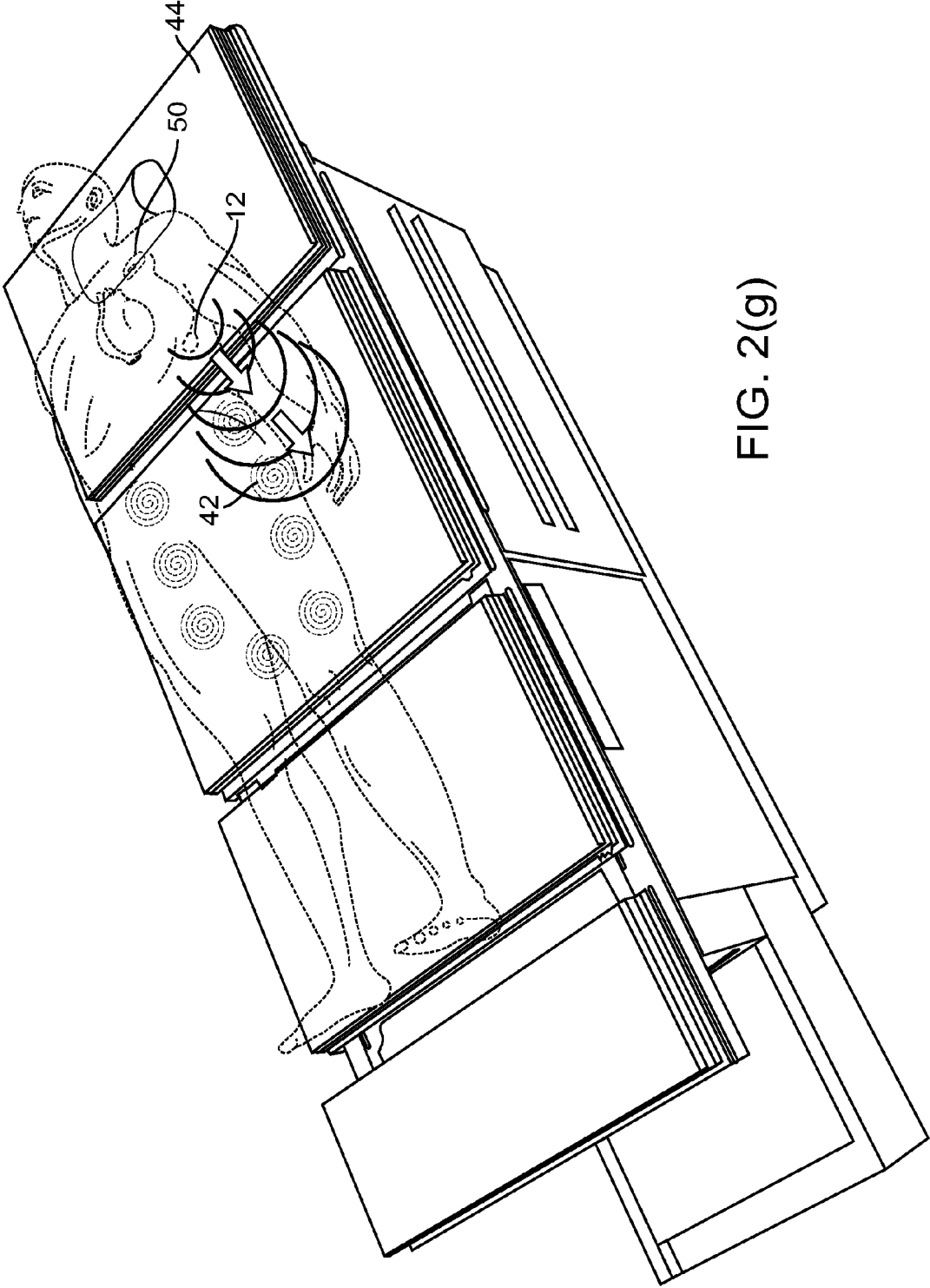

FIG. 2(g)

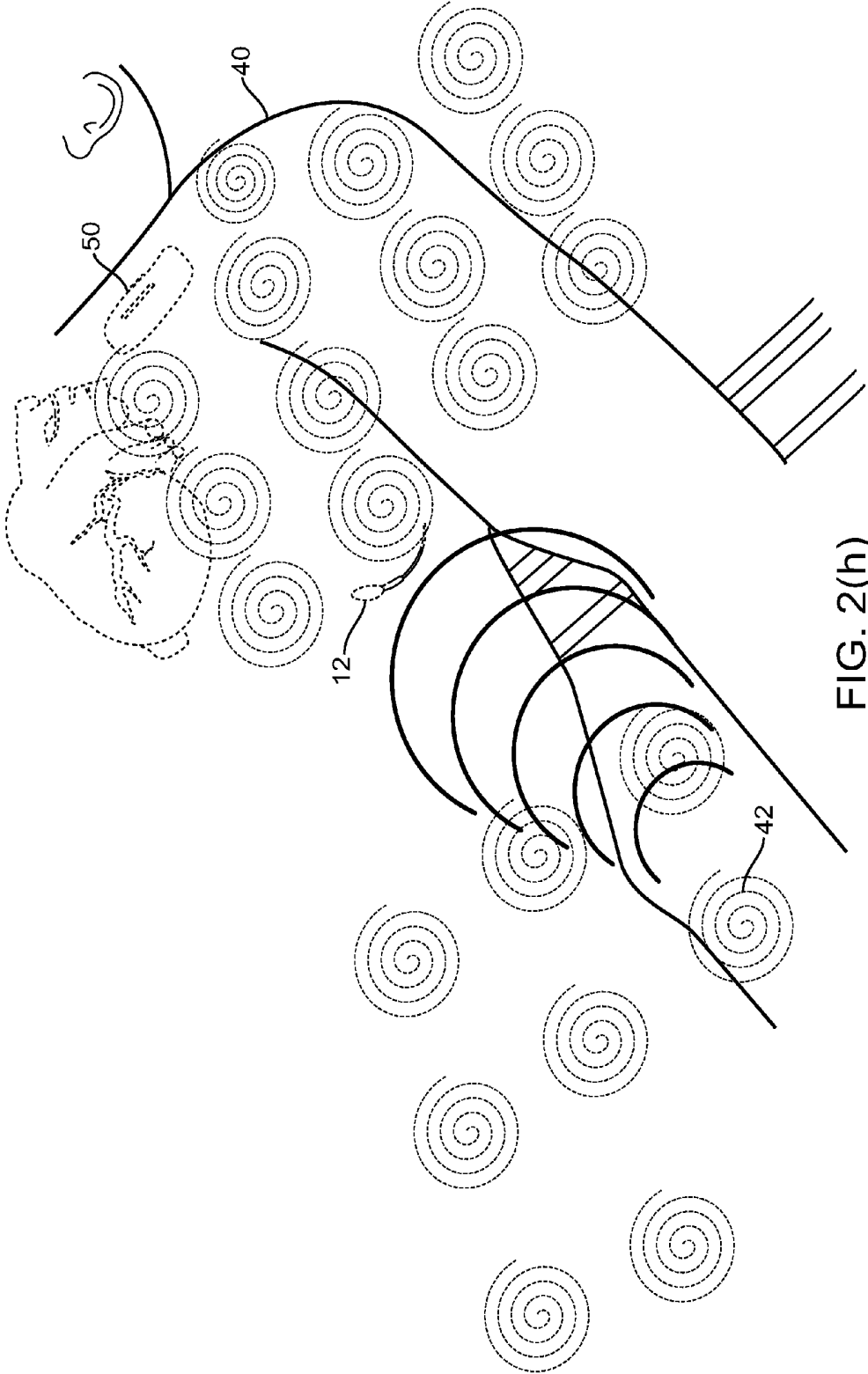

FIG. 2(h)

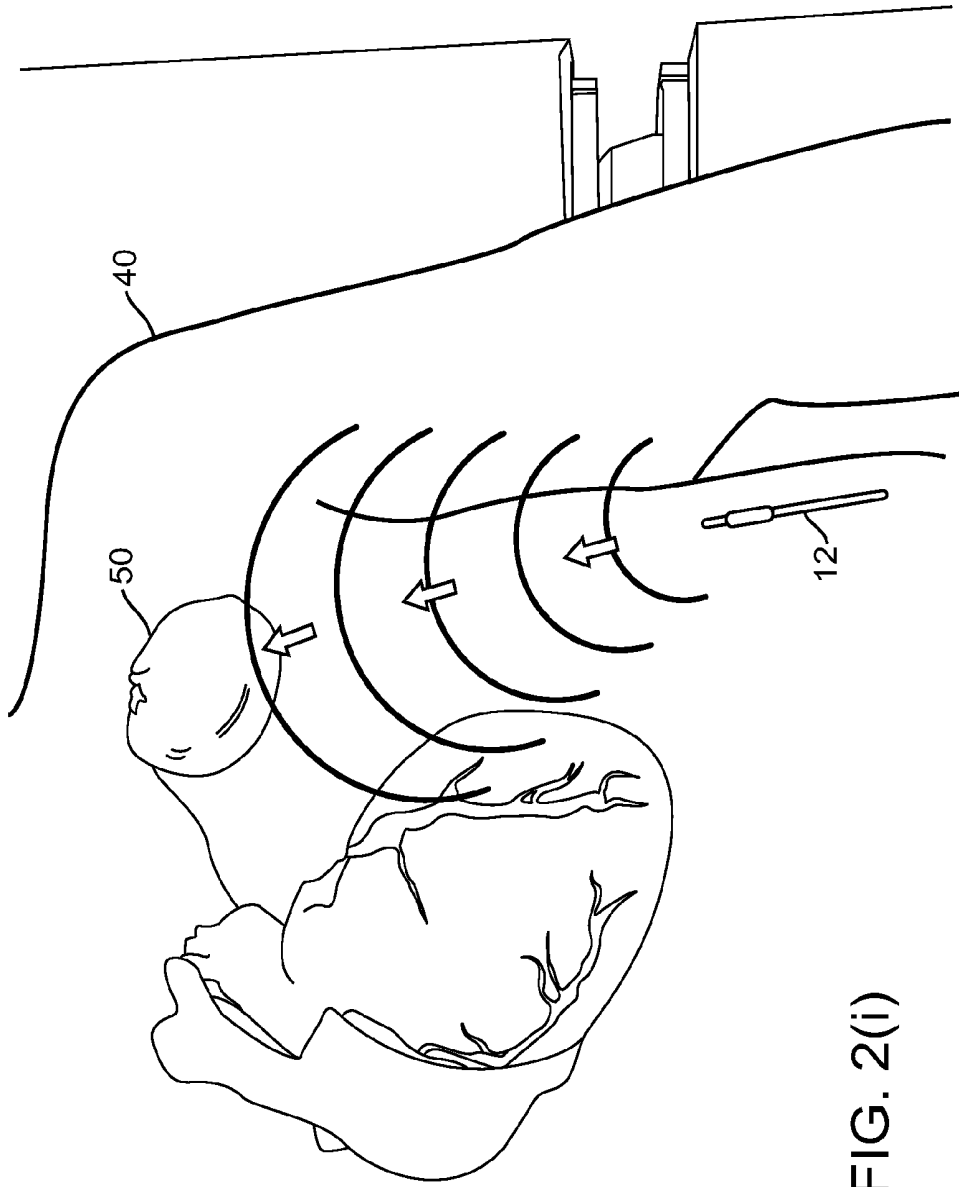

FIG. 2(i)

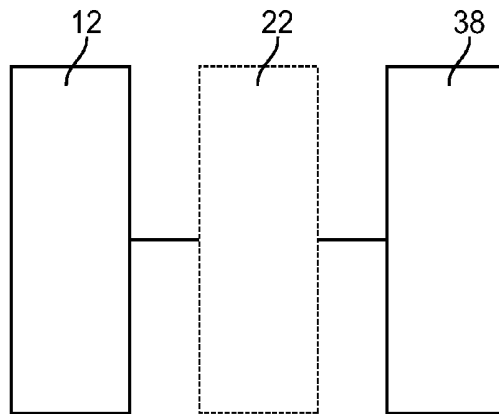

FIG. 6

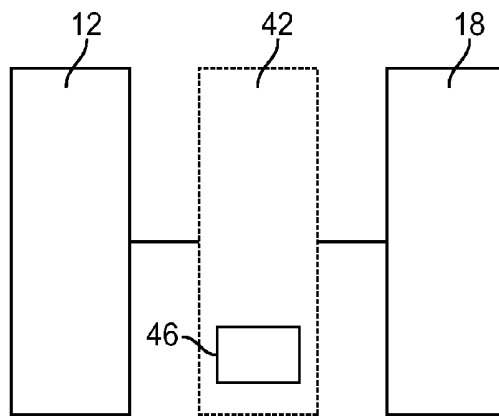

FIG. 7

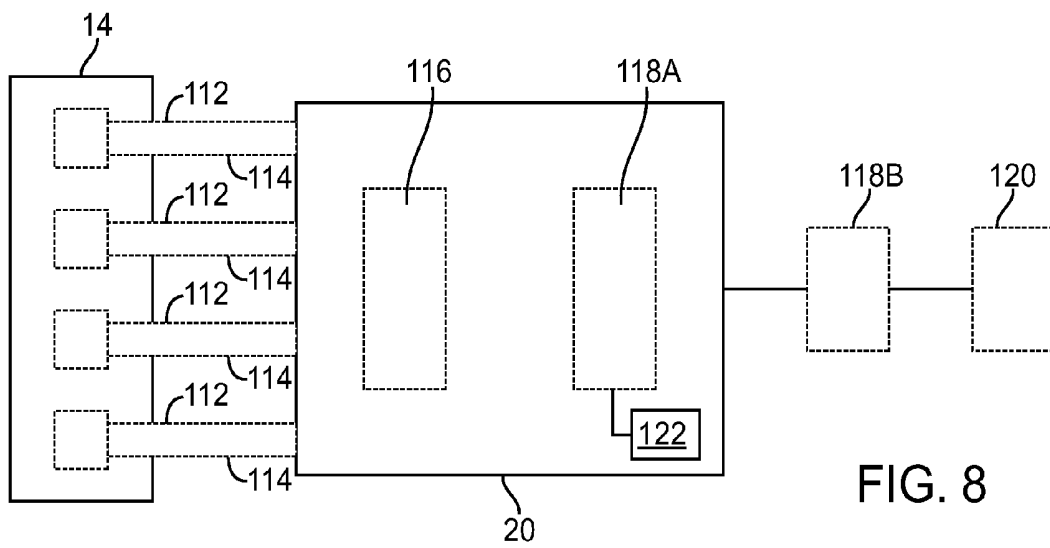

FIG. 8

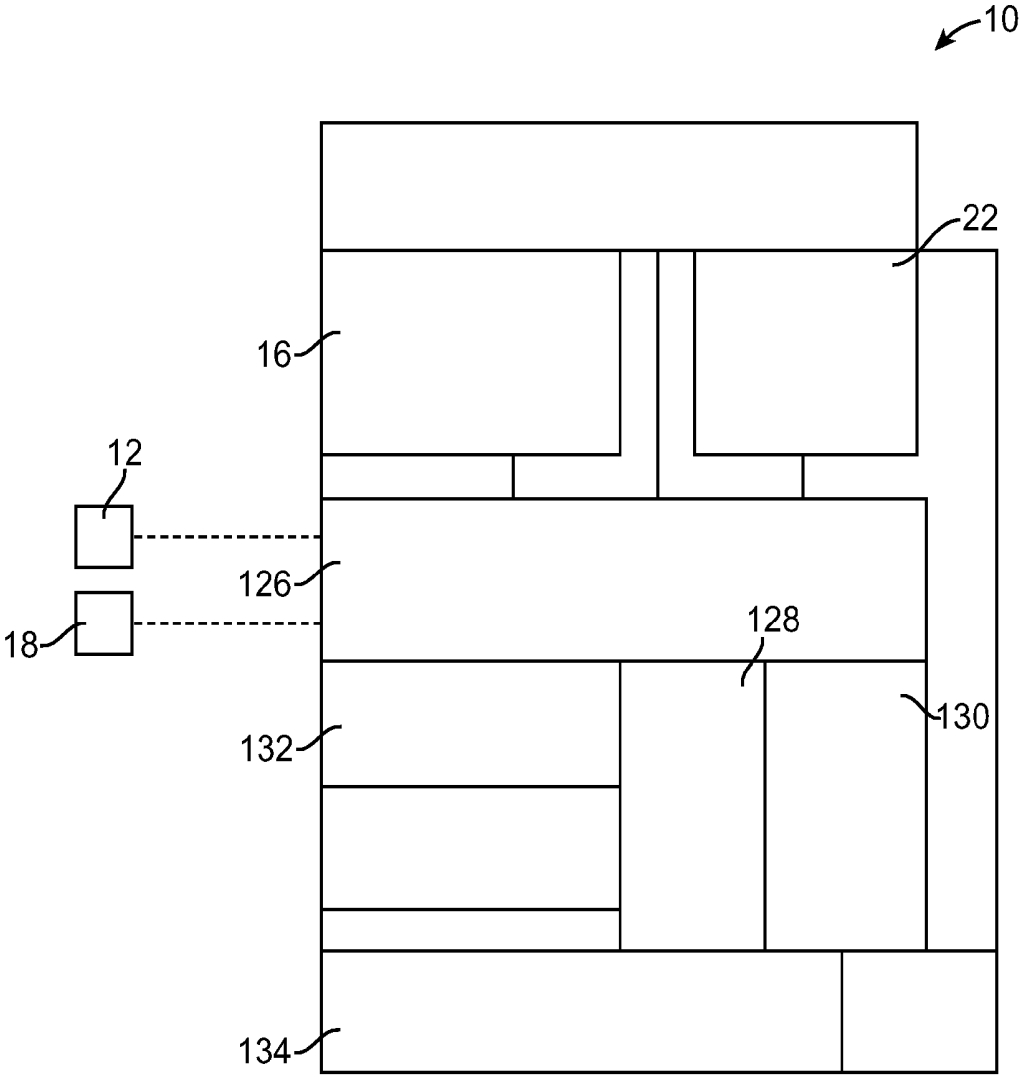

FIG. 9

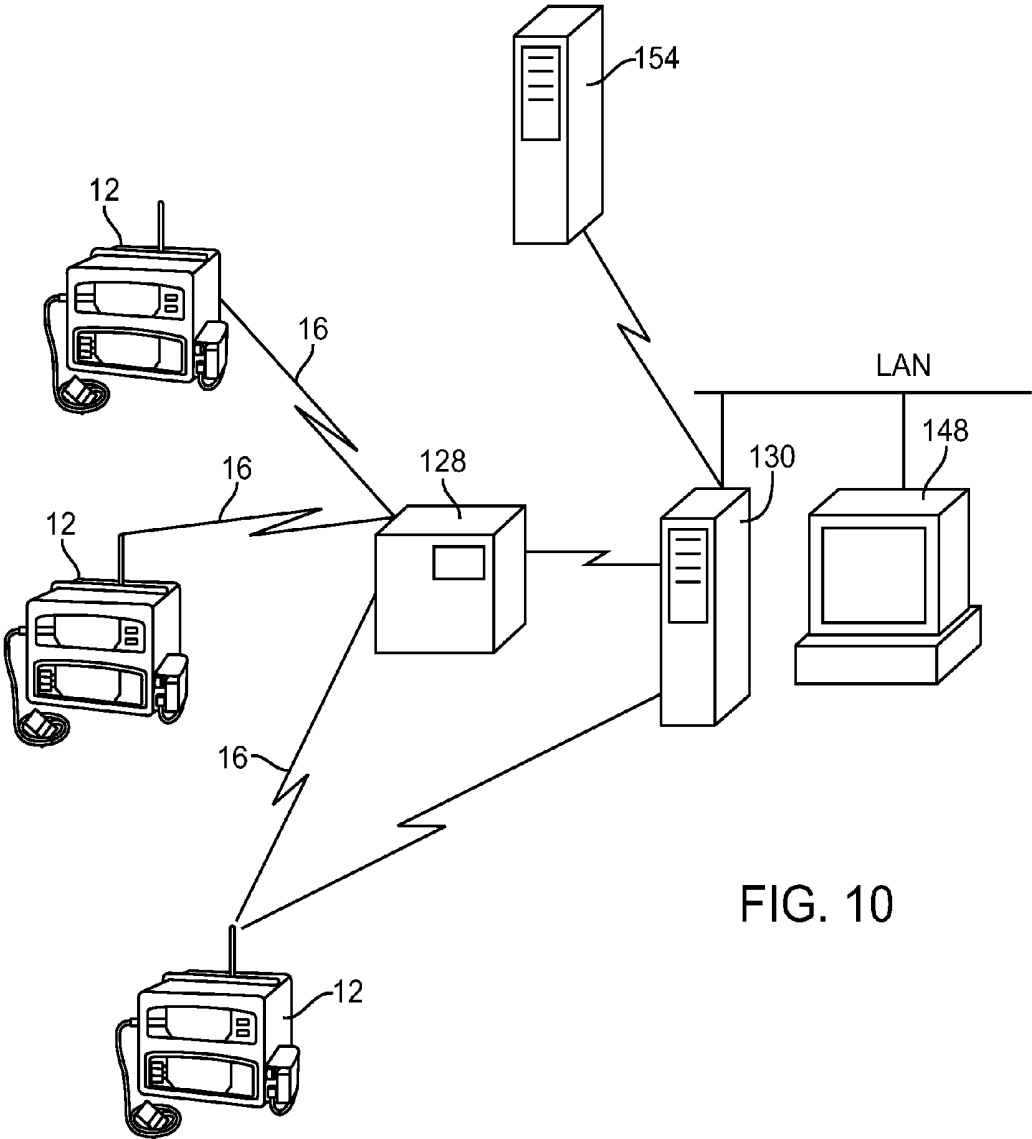

FIG. 10

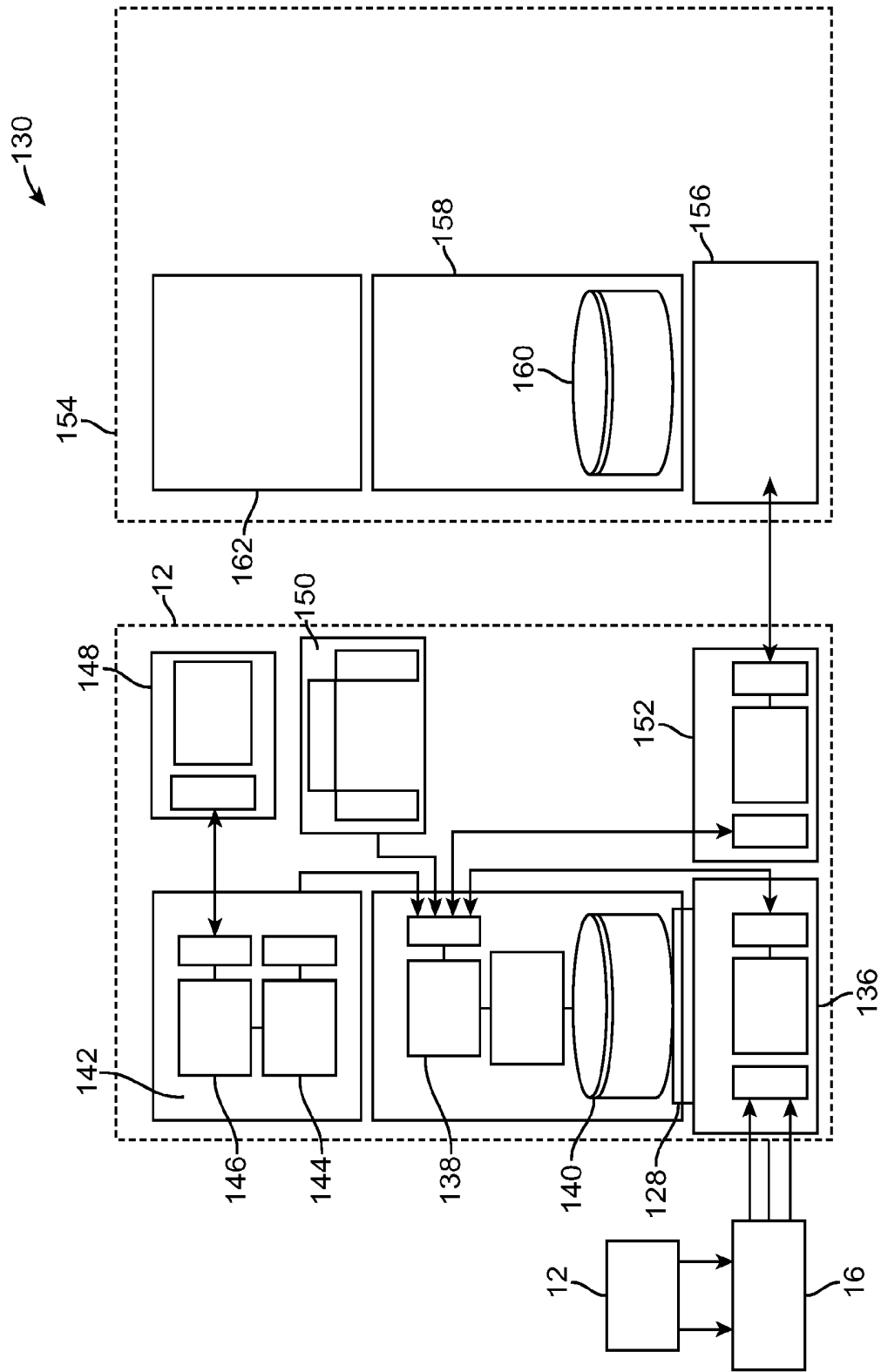

FIG. 11

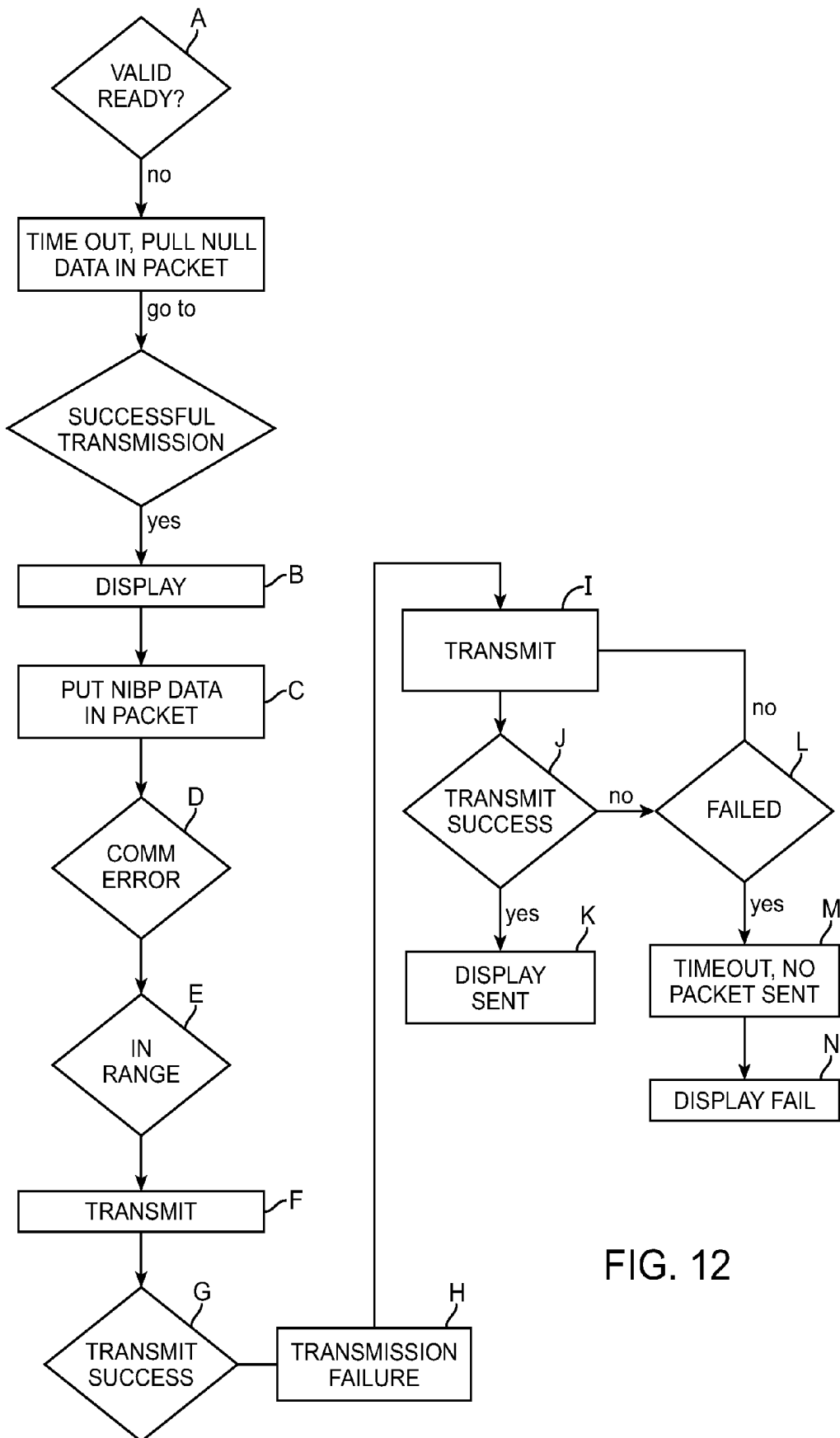

FIG. 12

INJECTABLE DEVICE FOR PHYSIOLOGICAL MONITORING

CROSS-REFERENCES TO RELATED APPLICATIONS

The present application claims the benefit under 35 USC 119(e) of U.S. Provisional Application Nos. 60/972,329, 60/972,336, 60/972,354 and 60/972,537, all filed Sep. 14, 2007, and 61/055,666 filed May 23, 2008; the full disclosures of which are incorporated herein by reference in their entirety.

The subject matter of the present application is related to the following applications: 60/972,512; 60/972,616; 60/972,363; 60/972,343; 60/972,581; 60/972,629; 60/972,316; 60/972,333; 60/972,359; 60/972,336; 60/972,340 all of which were filed on Sep. 14, 2007; 61/046,196 filed Apr. 18, 2008; 61/047,875 filed Apr. 25, 2008; 61/055,645, 61/055,656, 61/055,662, all filed May 23, 2008; and 61/079,746 filed Jul. 10, 2008.

The following applications are being filed concurrently with the present application, on Sep. 12, 2008: U.S. patent application Ser. No. 12/209,279 entitled "Multi-Sensor Patient Monitor to Detect Impending Cardiac Decompensation Prediction"; U.S. patent application Ser. No. 12/209,288 entitled "Adherent Device with Multiple Physiological Sensors"; U.S. patent application Ser. No. 12/209,479 entitled "Injectable Physiological Monitoring System"; U.S. patent application Ser. No. 12/209,262 entitled "Adherent Device for Cardiac Rhythm Management"; U.S. patent application Ser. No. 12/209,268 entitled "Adherent Device for Respiratory Monitoring"; U.S. patent application Ser. No. 12/209,269 entitled "Adherent Athletic Monitor"; U.S. patent application Ser. No. 12/209,259 entitled "Adherent Emergency Monitor"; U.S. patent application Ser. No. 12/209,273 entitled "Adherent Device with Physiological Sensors"; U.S. patent application Ser. No. 12/209,276 entitled "Medical Device Automatic Start-up upon Contact to Patient Tissue"; U.S. patent application Ser. No. 12/210,078 entitled "System and Methods for Wireless Body Fluid Monitoring"; U.S. patent application Ser. No. 12/209,265 entitled "Adherent Cardiac Monitor with Advanced Sensing Capabilities"; U.S. patent application Ser. No. 12/209,292 entitled "Adherent Device for Sleep Disordered Breathing"; U.S. patent application Ser. No. 12/209,278 entitled "Dynamic Pairing of Patients to Data Collection Gateways"; U.S. patent application Ser. No. 12/209,508 entitled "Adherent Multi-Sensor Device with Implantable Device Communications Capabilities"; U.S. patent application Ser. No. 12/209,528 entitled "Data Collection in a Multi-Sensor Patient Monitor"; U.S. patent application Ser. No. 12/209,271 entitled "Adherent Multi-Sensor Device with Empathic Monitoring"; U.S. patent application Ser. No. 12/209,274 entitled "Energy Management for Adherent Patient Monitor"; and U.S. patent application Ser. No. 12/209,294 entitled "Tracking and Security for Adherent Patient Monitor."

BACKGROUND OF THE INVENTION

Field of the Invention

This invention relates generally to systems and methods for remote patient monitoring, and more particularly, to systems and methods for remote patient monitoring with percutaneously implanted sensors.

Frequent monitoring of patients permits the patients' physician to detect worsening symptoms as they begin to occur, rather than waiting until a critical condition has been reached.

As such, home monitoring of patients with chronic conditions is becoming increasingly popular in the health care industry for the array of benefits it has the potential to provide. Potential benefits of home monitoring are numerous and include: better tracking and management of chronic disease conditions, earlier detection of changes in the patient condition, and reduction of overall health care expenses associated with long term disease management. The home monitoring of a number of diverse "chronic diseases" is of interest, where such diseases include diabetes, dietary disorders such as anorexia and obesity, depression, anxiety, epilepsy, respiratory diseases, AIDS and other chronic viral conditions, conditions associated with the long term use of immunosuppressant's, e.g., in transplant patients, asthma, chronic hypertension, chronic use of anticoagulants, and the like.

Of particular interest in the home monitoring sector of the health care industry is the remote monitoring of patients with heart failure (HF), also known as congestive heart failure. HF is a syndrome in which the heart is unable to efficiently pump blood to the vital organs. Most instances of HF occur because of a decreased myocardial capacity to contract (systolic dysfunction). However, HF can also result when an increased pressure-stroke-volume load is imposed on the heart, such as when the heart is unable to expand sufficiently during diastole to accommodate the ventricular volume, causing an increased pressure load (diastolic dysfunction).

In either case, HF is characterized by diminished cardiac output and/or damming back of blood in the venous system. In HF, there is a shift in the cardiac function curve and an increase in blood volume caused in part by fluid retention by the kidneys. Indeed, many of the significant morphologic changes encountered in HF are distant from the heart and are produced by the hypoxic and congestive effects of the failing circulation upon other organs and tissues. One of the major symptoms of HF is edema, which has been defined as the excessive accumulation of interstitial fluid, either localized or generalized.

HF is the most common indication for hospitalization among adults over 65 years of age, and the rate of admission for this condition has increased progressively over the past two decades. It has been estimated that HF affects more than 3 million patients in the U.S. (O'Connell, J. B. et al., *J. Heart Lung Transpl.*, 13(4):S107-112 (1993)).

In the conventional management of HF patients, where help is sought only in crisis, a cycle occurs where patients fail to recognize early symptoms and do not seek timely help from their care-givers, leading to emergency department admissions (Miller, P. Z., *Home monitoring for congestive heart-failure patients*, Caring Magazine, 53-54 (August 1995)). Recently, a prospective, randomized trial of 282 patients was conducted to assess the effect of the intervention on the rate of admission, quality of life, and cost of medical care. In this study, a nurse-directed, multi-disciplinary intervention (which consisted of comprehensive education of the patient and family, diet, social-service consultation and planning, review of medications, and intensive assessment of patient condition and follow-up) resulted in fewer readmissions than the conventional treatment group and a concomitant overall decrease in the cost of care (Rich, M. W. et al., *New Engl. J. Med.*, 333:1190-95 (1995)). Similarly, comprehensive discharge planning and a home follow-up program was shown to decrease the number of readmissions and total hospital charges in an elderly population (Naylor, M. et al., *Amer. College Physicians*, 120:999-1006 (1994)). Therefore, home monitoring is of particular interest in the HF management segment of the health care industry.

Another area in which home-monitoring is of particular interest is in the remote monitoring of a patient parameter that provides information on the titration of a drug, particularly with drugs that have a consequential effect following administration, such as insulin, anticoagulants, ACE inhibitors, beta-blockers, diuretics and the like.

Although a number of different home monitoring systems have been developed, there is continued interest in the development of new monitoring systems. Of particular interest would be the development of a system that provides for improved patient compliance, ease of use, etc. Of more particular interest would be the development of such a system that is particularly suited for use in the remote monitoring of patients suffering from HF.

Subcutaneous implantation of sensors has been achieved with an insertion and tunneling tool. The tunneling tool includes a stylet and a peel-away sheath. The tunneling tool is inserted into an incision and the stylet is withdrawn once the tunneling tool reaches a desired position. An electrode segment is inserted into the subcutaneous tunnel and the peel-away sheath is removed. In another delivery device, a pointed tip is inserted through the skin and a plunger is actuated to drive the sensor to its desired location.

In other delivery systems, an implant trocar includes a cannula for puncturing the skin and an obturator for delivering the implant. A spring element received within the cannula prevents the sensor from falling out during the implant process. Another sensor delivery device includes an injector that has a tubular body divided into two adjacent segments with a hollow interior bore. A pair of laterally adjacent tines extend longitudinally from the first segment to the distal end of the tubular body. A plunger rod has an exterior diameter just slightly larger than the interior diameter of the tubular body. With the second segment inserted beneath the skin, the push rod is advanced longitudinally through the tubular body, thereby pushing the sensor through the bore. As the implant and rod pass through the second segment, the tines are forced radially away from each other, thereby dilating or expanding the incision, and facilitating implant. The instrument is removed from the incision following implantation.

For the above and other reasons, it would be desirable to provide an improved percutaneous sensor device for physiological monitoring.

BRIEF SUMMARY OF THE INVENTION

In a first aspect, embodiments of the present invention provide an injectable detecting device for use in physiological monitoring is provided. The device comprises a plurality of sensors axially spaced along a body that provide an indication of at least one physiological event of a patient, a monitoring unit within the body coupled to the plurality of sensors configured to receive data from the plurality of sensors and create processed patient data, a power source within the body coupled to the monitoring unit, and a communication antenna external to the body coupled to the monitoring unit configured to transfer data to/from other devices.

In many embodiments, the monitoring unit includes a processor. In many embodiments, the processor includes program instructions for evaluating values received from the sensors with respect to acceptable physiological ranges for each value received by the processor and determine variances.

In many embodiments, the monitoring unit includes logic resources that determine heart failure status and predict impending decompensation.

In many embodiments, the monitoring unit is configured to perform one or more of, data compression, prioritizing of sensing by a sensor, cycling sensors, monitoring all or some of sensor data by all or a portion of the sensors, sensing by the sensors in real time, noise blanking to provide that sensor data is not stored if a selected noise level is determined, low-power of battery caching and decimation of old sensor data.

In many embodiments, the monitoring unit includes a notification device configured to provide notification when values received from the plurality of sensors are not within acceptable physiological ranges.

In many embodiments, the monitoring unit is configured to serve as a communication hub for multiple medical devices, coordinating sensor data and therapy delivery while transmitting and receiving data from a remote monitoring system.

In many embodiments, the monitoring unit is configured to deactivate selected sensors to reduce redundancy.

In many embodiments, each of a sensor is selected from at least one of, bioimpedance, heart rate, heart rhythm, HRV, HRT, heart sounds, respiratory sounds, respiratory rate and respiratory rate variability, blood pressure, activity, posture, wake/sleep, orthopnea, temperature, heat flux and an accelerometer.

In many embodiments, each of a sensor is an activity sensor selected from at least one of, ball switch, accelerometer, minute ventilation, HR, bioimpedance noise, skin temperature/heat flux, BP, muscle noise and posture.

In many embodiments, the sensors are made of at least a material selected from, silicone, polyurethane, Nitinol, titanium, a biocompatible material, ceramics and a bioabsorbable material.

In many embodiments, at least a portion of sensors of the plurality of sensors have an insulative material selected from, PEEK, ETFE, PTFE, and polyimide, silicon, polyurethane.

In many embodiments, at least a portion of sensors of the plurality of sensors have openings or an absorbent material configured to sample a hydration level or electrolyte level in a surrounding tissue site of the plurality of sensors.

In many embodiments, the plurality of sensors includes current delivery electrodes and sensing electrodes.

In many embodiments, the outputs of the plurality of sensors is used to calculate and monitor blended indices. The blended indices include at least one of, heart rate (HR) or respiratory rate (RR) response to activity, HR/RR response to posture change, HR+RR, HR/RR+bioimpedance, and/or minute ventilation/accelerometer.

In many embodiments, the body and antenna are injectable in the patient by at least one of, catheter delivery, blunt tunneling, insertion with a needle, by injection, with a gun or syringe device with a stiffening wire stylet, guidewire, or combination of stylet or guidewire with a catheter.

In many embodiments, the body is flexible.

In many embodiments, at least a portion of the body has a drug eluting coating.

In many embodiments, the power source comprises a rechargeable battery transcutaneously chargeable with an external unit.

BRIEF DESCRIPTION OF THE DRAWINGS

FIG. 1 is a block diagram illustrating one embodiment of a patient monitoring system of the present invention.

FIG. 2(a) illustrates one embodiment of an implanted sensor device of the present invention that is injectable and includes multiple sensors, power and communication and a communication antenna.

FIG. 2(b) illustrates the insertion of the device of FIG. 2(a) into an injector.

FIG. 2(c) illustrates the device of FIG. 2(a) in the injector and ready to be introduced into the patient.

FIG. 2(d) illustrates the implanted sensor device of FIG. 2(a).

FIG. 2(e) illustrates the implanted sensor device of FIG. 2(a) as it flexes from a rigid state in the body.

FIG. 2(f) illustrates a patient laying on top of a matt that has coils, where downloading of patient data and recharging can occur via the matt.

FIG. 2(g) illustrates the patient laying on top of the matt from FIG. 2(f) and the downloading of data from the sensors to the matt.

FIG. 2(h) is a close up view of FIG. 2(g), showing the downloading of data from the sensors to the matt, and then transfer of the data from the matt to a modem.

FIG. 2(i) illustrates a patient with an implanted device, such as a pacing device, and the implanted device of FIG. 2(a) in communication with the implanted device.

FIG. 3 illustrates one embodiment of an energy management device that is coupled to the plurality of sensors of FIG. 1.

FIG. 4 illustrates one embodiment of present invention illustrating logic resources configured to receive data from the sensors and/or the processed patient for monitoring purposes, analysis and/or prediction purposes.

FIG. 5 illustrates an embodiment of the patient monitoring system of the present invention with a memory management device.

FIG. 6 illustrates an embodiment of the patient monitoring system of the present invention with an external device coupled to the sensors.

FIG. 7 illustrates an embodiment of the patient monitoring system of the present invention with a notification device.

FIG. 8 is a block diagram illustrating an embodiment of the present invention with sensor leads that convey signals from the sensors to a monitoring unit at the detecting system, or through a wireless communication device to a remote monitoring system.

FIG. 9 is a block diagram illustrating an embodiment of the present invention with a control unit at the detecting system and/or the remote monitoring system.

FIG. 10 is a block diagram illustrating an embodiment of the present invention where a control unit encodes patient data and transmits it to a wireless network storage unit at the remote monitoring system.

FIG. 11 is a block diagram illustrating one embodiment of an internal structure of a main data collection station at the remote monitoring system of the present invention.

FIG. 12 is a flow chart illustrating an embodiment of the present invention with operation steps performed by the system of the present invention in transmitting information to the main data collection station.

DETAILED DESCRIPTION OF THE INVENTION

The present invention is directed to a heart failure patient management system consisting of one or more subcutaneously injectable devices inserted below the patient's skin. The system continuously monitors physiological parameters, communicates wirelessly with a remote center, and provides alerts when necessary.

The heart failure patient management system monitors physiological parameters and uses a proprietary algorithm to determine heart failure status and predict impending decompensation. The one or more injectable devices communicate

with a remote center, preferably via an intermediate device in the patient's home. In some embodiments, the injectable device monitoring unit receives the data and applies the prediction algorithm. When a flag is raised, the center may communicate with the patient, hospital, nurse, and/or physician to allow for therapeutic intervention to prevent decompensation.

The injectable devices would perform the following functions: initiation, programming, measuring, storing, analyzing, communicating, predicting, and displaying.

The system contains one or more injectable devices, each consisting of a hermetically sealed package containing and contains a power source, memory, logic, wireless communication capabilities, and a subset of the following physiological sensors: bioimpedance, heart rate (ave, min, max), heart rhythm, HRV, HRT, heart sounds (e.g. S3), respiratory sounds, blood pressure, activity, posture, wake/sleep, orthopnea, and temperature/heat flux. The activity sensor may be one of the following: ball switch, accelerometer, minute ventilation, HR, bioimpedance noise, skin temperature/heat flux, BP, muscle noise, and posture.

The injectable devices may communicate directly with each other, allow for coordinated sensing between the units. The injectable devices may also communicate with an external unit (either adherent, wearable, or non-wearable) or with an implantable device, such as a cardiac rhythm management device.

The injectable devices wirelessly communicates with a remote center. Such communication may occur directly (via a cellular or Wi-Fi network), or indirectly through an intermediate device. The intermediate device may consist of multiple devices which communicate wired or wirelessly to relay data to the remote center.

The injectable devices may have a rechargeable battery, which is transcutaneously charged with an external unit.

The injectable device package may contain one or more features to allow for tissue anchoring. Such features may include passive or actively-deployed barbs or anchors, tissue adhesion pads, and/or suture loops. Tissue adhesion pads (or grooves or holes) may be designed to be small enough to stabilize the device while allowing for easy extraction.

The injectable devices may use one or more of the following component technologies: flex circuits, thin film resistors, and organic transistors.

The injectable devices may have one of the following form factors: cylinder, dog-bone, half dog-bone, trapezoidal cross-section, semicircular cross-section, star-shaped cross-section, v-shaped cross-section, helical/spiral, fin electrodes, and linear device with a radius of curvature to match radius of implant site.

The injectable devices may be constructed of one or more of the following materials: silicone, polyurethane, Nitinol, a biocompatible material, and a bioabsorbable material. The electrodes may use one or more of the following metal conductors: platinum, MP35N, MP35N/Ag core, platinum/tantalum core, stainless steel, and titanium. Insulative materials may include one or more of the following: PEEK, ETFE, PTFE, and polyimide. Ceramics may be used to enclose electronics (especially the RF unit, to enable RF transmission).

The injectable devices may contain a drug eluting coating, which would slowly release a drug such as an antibiotic or anti-inflammatory agent.

The injectable devices may contain openings and/or absorbent material, through which the device may sample the hydration level and/or electrolytes in the surrounding tissue.

The injectable devices may include multiple features to enhance physiological sensing performance. Such features

may include multiple sensing vectors, including redundant vectors. This configuration would allow the injectable devices to determine the optimal sensing configuration, and electronically reposition each sensing vector.

The injectable device electrodes may be partially masked to minimize contamination of the sensed signal. The size and shape of current delivery electrodes (for bioimpedance) and sensing electrodes would be optimized to maximize sensing performance.

While the present invention is intended for heart failure patient monitoring, the system may be applicable to any human application in which wireless physiological monitoring and prediction is required.

The percutaneous sensing device may be used in conjunction with remote patient monitoring to track a patient's physiological status, detect and predict negative physiological events. In one embodiment, the implanted sensing device includes a plurality of sensors that are used in combination to enhance detection and prediction capabilities as more fully explained below.

In one embodiment, illustrated in FIG. 1, the system 10 includes an injectable detecting system 12 that includes a plurality of sensors 14 and/or electrodes, that provide an indication of at least one physiological event of a patient. The injectable detecting system 12 is inserted subcutaneously. In one embodiment the injectable detecting system 12 is inserted in the patient's thorax. The system 10 also includes a wireless communication device 16, coupled to the plurality of sensors 14. The wireless communication device transfers patient data directly or indirectly from the plurality of sensors 14 to a remote monitoring system 18. The remote monitoring system 18 uses data from the sensors to determine the patient's status. The system 10 can continuously, or non-continuously, monitor the patient, alerts are provided as necessary and medical intervention is provided when required. In one embodiment, the wireless communication device 16 is a wireless local area network for receiving data from the plurality of sensors.

The sensors 14 are subcutaneously inserted with the injectable detecting system 12 that is catheter based, blunt tunneling (with either a separate tunneling tool or a wire-stiffened lead), needle insertion gun or syringe-like injection. The injectable detecting system 12 can be flexible, and be used with a stiffening wire, stylet, catheter or guidewire. The injectable detecting system 12 can include any of the following to assist in subsequent extraction: (i) an isodiametric profile, (ii) a breakaway anchor, (iii) a bioabsorbable material, (iv) coatings to limit tissue in-growth, (v) an electrically activated or fusible anchor, and the like. The injectable detecting system 12 can be modular, containing multiple connected components, a subset of which is easily extractable.

The injectable detecting system 12 can be inserted in the patient in a non-sterile or sterile setting, non-surgical setting or surgical setting, implanted with or without anesthesia and implanted with or without imaging assistance from an imaging system. The injectable detecting system 12 can be anchored in the patient by a variety of means including but not limited to, barbs, anchors, tissue adhesion pads, suture loops, with sensor shapes that conform to adjacent tissue anatomy or provide pressure against the adjacent tissue, with the use of self-expanding materials such as a nitinol anchor and the like.

FIG. 2(a) shows one embodiment of the injectable detecting system 12 with sensors 14 that is introduced below the skin surface. The sensor device includes power and communication elements 32, and a communication antenna 34. The antenna may be a self expanding antenna expandable from a

first compressed shape to a second expanded shape, such as disclosed in U.S. Provisional Application No. 61/084,567, filed Jul. 29, 2008 entitled "Communication-Anchor Loop For Injectable Device", the full disclosure of which is incorporated herein by reference. FIG. 2(b) illustrates the injectable detecting system 12 being loaded into an injector 36 having a needle end 38. FIG. 2(c) shows the injectable detecting system 12 being introduced subcutaneously into a patient 40. FIG. 2(d) shows the injectable detecting system 12 being implanted subcutaneously from the injector 36. In FIG. 2(e), the injector 36 is removed and the injectable detecting system 12 flexes from a rigid configuration.

In one embodiment, illustrated in FIGS. 2(f) and 2(g), recharging coils 42 are placed in a mat 44 on the patient's bed, such as under a mattress pad. Recharging of the sensors/battery and data transfer can occur during sleep of the patient. The rechargeable batteries can be transcutaneously charged with an external unit other than the mat. FIG. 2(g) shows downloading from the sensors and data transfer during sleep of the patient. In FIG. 2(h), the sensors download data to the mat and a modem is used from data transfer. In FIG. 2(i), an implantable device 50, such as a pacing device communicates with the injectable detecting system 12 of FIG. 2(a).

In one embodiment, the wireless communication device 16 is configured to receive instructional data from the remote monitoring system and communicate instructions to the injectable detecting system.

As illustrated in FIG. 3, an energy management device 19 is coupled to the plurality of sensors. In one embodiment, the energy management device 19 is part of the detecting system. In various embodiments, the energy management device 19 performs one or more of, modulate drive levels per sensed signal of a sensor 14, modulate a clock speed to optimize energy, watch cell voltage drop—unload cell, coulomb-meter or other battery monitor, sensor dropoff at an end of life of a battery coupled to a sensor, battery end of life dropoff to transfer data, elective replacement indicator, call center notification, sensing windows by the sensors 14 based on a monitored physiological parameter and sensing rate control.

In one embodiment, the energy management device 19 is configured to manage energy by at least one of, a thermoelectric unit, kinetics, fuel cell, nuclear power, a micro-battery and with a rechargeable device.

The system 10 is configured to automatically detect events. The system 10 automatically detects events by at least one of, high noise states, physiological quietness, sensor continuity and compliance. In response to a detected physiological event, patient states are identified when data collection is inappropriate. In response to a detected physiological event, patient states are identified when data collection is desirable. Patient states include, physiological quietness, rest, relaxation, agitation, movement, lack of movement and a patient's higher level of patient activity.

The system uses an intelligent combination of sensors to enhance detection and prediction capabilities, as more fully disclosed in U.S. patent application Ser. Nos. 60/972,537 filed Sep. 14, 2008 and 61/055,666 filed May 23, 2008, both titled "Adherent Device with Multiple Physiological Sensors", incorporated herein by reference, and as more fully explained below.

In one embodiment, the injectable detecting system 12 communicates with the remote monitoring system 18 periodically or in response to a trigger event. The trigger event can include but is not limited to at least one of, time of day, if a memory is full, if an action is patient initiated, if an action is

initiated from the remote monitoring system, a diagnostic event of the monitoring system, an alarm trigger, a mechanical trigger, and the like.

The injectable detecting system **12** can continuously, or non-continuously, monitor the patient, alerts are provided as necessary and medical intervention is provided when required. In one embodiment, the wireless communication device **16** is a wireless local area network for receiving data from the plurality of sensors in the injectable detecting system.

A processor **20** is coupled to the plurality of sensors **14** in the injectable detecting system **12**. The processor **20** receives data from the plurality of sensors **14** and creates processed patient data. In one embodiment, the processor **20** is at the remote monitoring system **18**. In another embodiment, the processor **20** is at the detecting system **12**. The processor **20** can be integral with a monitoring unit **22** that is part of the injectable detecting system **12** or part of the remote monitoring system **18**.

The processor **20** has program instructions for evaluating values received from the sensors **14** with respect to acceptable physiological ranges for each value received by the processor **20** and determine variances. The processor **20** can receive and store a sensed measured parameter from the sensors **14**, compare the sensed measured value with a predetermined target value, determine a variance, accept and store a new predetermined target value and also store a series of questions from the remote monitoring system **18**.

As illustrated in FIG. 4, logic resources **24** are provided that take the data from the sensors **14**, and/or the processed patient data from the processor **20**, to predict an impending decompensation. The logic resources **24** can be at the remote monitoring system **18** or at the detecting system **12**, such as in the monitoring unit **22**.

In one embodiment, a memory management device **25** is provided as illustrated in FIG. 5. In various embodiments, the memory management device **25** performs one or more of data compression, prioritizing of sensing by a sensor **14**, monitoring all or some of sensor data by all or a portion of the sensors **14**, sensing by the sensors **14** in real time, noise blanking to provide that sensor data is not stored if a selected noise level is determined, low-power of battery caching and decimation of old sensor data.

The injectable detecting system **12** can provide a variety of different functions, including but not limited to, initiation, programming, measuring, storing, analyzing, communicating, predicting, and displaying of a physiological event of the patient. The injectable detecting system **12** can be sealed, such as housed in a hermetically sealed package. In one embodiment, at least a portion of the sealed packages include a power source, a memory, logic resources and a wireless communication device. In one embodiment, an antenna is included that is exterior to the sealed package of the injectable detecting system **12**. In one embodiment, the sensors **14** include, flex circuits, thin film resistors, organic transistors and the like. The sensors **14** can include ceramics, titanium PEEK, along with a silicon, PU or other insulative adherent sealant, to enclose the electronics. Additionally, all or part of the injectable detecting system **12** can include drug eluting coatings, including but not limited to, an antibiotic, anti-inflammatory agent and the like.

A wide variety of different sensors **14** can be utilized, including but not limited to, bioimpedance, heart rate, heart rhythm, HRV, HRT, heart sounds, respiration rate, respiration rate variability, respiratory sounds, SpO₂, blood pressure, activity, posture, wake/sleep, orthopnea, temperature, heat flux, an accelerometer, glucose sensor, other chemical sen-

sors associated with cardiac conditions, and the like. A variety of activity sensors can be utilized, including but not limited to a, ball switch, accelerometer, minute ventilation, HR, bioimpedance noise, skin temperature/heat flux, BP, muscle noise, posture and the like.

The output of the sensors **14** can have multiple features to enhance physiological sensing performance. These multiple features have multiple sensing vectors that can include redundant vectors. The sensors **14** can include current delivery electrodes and sensing electrodes. Size and shape of current delivery electrodes, and the sensing electrodes, can be optimized to maximize sensing performance. The system **10** can be configured to determine an optimal sensing configuration and electronically reposition at least a portion of a sensing vector of a sensing electrode. The multiple features enhance the system's **10** ability to determine an optimal sensing configuration and electronically reposition sensing vectors. In one embodiment, the sensors **14** can be partially masked to minimize contamination of parameters sensed by the sensors **14**.

The size and shape of current delivery electrodes, for bioimpedance, and sensing electrodes can be optimized to maximize sensing performance. Additionally, the outputs of the sensors **14** can be used to calculate and monitor blended indices. Examples of the blended indices include but are not limited to, heart rate (HR) or respiratory rate (RR) response to activity, HR/RR response to posture change, HR+RR, HR/RR+bioimpedance, and/or minute ventilation/accelerometer and the like.

The sensors **14** can be cycled in order to manage energy, and different sensors **14** can sample at different times. By way of illustration, and without limitation, instead of each sensor **14** being sampled at a physiologically relevant interval, e.g. every 30 seconds, one sensor **14** can be sampled at each interval, and sampling cycles between available sensors.

By way of illustration, and without limitation, the sensors **14** can sample 5 seconds for every minute for ECG, once a second for an accelerometer sensor, and 10 seconds for every 5 minutes for impedance.

In one embodiment, a first sensor **14** is a core sensor **14** that continuously monitors and detects, and a second sensor **14** verifies a physiological status in response to the core sensor **14** raising a flag. Additionally, some sensors **14** can be used for short term tracking, and other sensors **14** used for long term tracking.

The injectable detecting system **12** is inserted into the patient by a variety of means, including but not limited to, catheter delivery, blunt tunneling, insertion with a needle, by injection, with a gun or syringe device with a stiffening wire and stylet and the like. The sensors **14** can be inserted in the patient in a non-sterile or sterile setting, non-surgical setting or surgical setting, injected with or without anesthesia and injected with or without imaging assistance. The injectable detecting system **12** can be anchored in the patient by a variety of means including but not limited to, barbs, anchors, tissue adhesion pads, suture loops.

The injectable detecting system **12** can come in a variety of different form factors including but not limited to, cylinder, dog-bone, half dog-bone, trapezoidal cross-section, semicircular cross-section, star-shaped cross-section, v-shaped cross-section, L-shaped, canted, W shaped, or in other shapes that assist in their percutaneous delivery, S-shaped, sine-wave shaped, J-shaped, any polygonal shape, helical/spiral, fin electrodes, and linear device with a radius of curvature to match a radius of the injection site and the like. Further, the injectable detecting system **12** can have flexible body con-

figurations. Additionally, the injectable detecting system 12 can be configured to deactivate selected sensors 14 to reduce redundancy.

The sensors 14 can be made of a variety of materials, including but not limited to, silicone, polyurethane, Nitinol, a biocompatible material, a bioabsorbable material and the like. Electrode sensors 14 can have a variety of different conductors, including but not limited to, platinum, MP35N which is a nickel-cobalt-chromium-molybdenum alloy, MP35N/Ag core, platinum/tantalum core, stainless steel, titanium and the like. The sensors 14 can have insulative materials, including but not limited to, polyetheretherketone (PEEK), ethylene-tetrafluoroethylene (ETFE), polytetrafluoroethylene (PTFE), polyimide, silicon, polyurethane, and the like. Further, the sensors 14 can have openings, or an absorbent material, configured to sample a hydration level or electrolyte level in a surrounding tissue site at the location of the sensor 14. The sensor 14 electrodes can be made of a variety of materials, including but not limited to platinum, iridium, titanium, and the like. Electrode coatings can be included, such as iridium oxide, platinum black, TiN, and the like.

The injectable detecting system 12 can include one or more rechargeable batteries 36 that can be transcutaneously chargeable with an external unit.

Referring to FIG. 6, in one embodiment, an external device 38, including a medical treatment device, is coupled to the injectable detecting system 12. The external device 38 can be coupled to a monitoring unit 22 that is part of the injectable detecting system 12, or in direct communication with the sensors 14. A variety of different external devices 38 can be used, including but not limited to, a weight scale, blood pressure cuff, cardiac rhythm management device, a medical treatment device, medicament dispenser, glucose monitor, insulin pump, drug delivery pumps, drug delivery patches, and the like. Suitable cardiac rhythm management devices include but are not limited to, Boston Scientific's Latitude system, Medtronic's CareLink system, St. Jude Medical's HouseCall system and the like. Such communication may occur directly or via an external translator unit.

The external device 38 can be coupled to an auxiliary input of the monitoring unit 22 at the injectable detecting system 12 or to the monitoring system 22 at the remote monitoring system 18. Additionally, an automated reader can be coupled to an auxiliary input in order to allow a single monitoring unit 22 to be used by multiple patients. As previously mentioned above, the monitoring unit 22 can be at the remote monitoring system 18 and each patient can have a patient identifier (ID) including a distinct patient identifier. In addition, the ID identifier can also contain patient specific configuration parameters. The automated reader can scan the patient identifier ID and transmit the patient ID number with a patient data packet such that the main data collection station can identify the patient.

It will be appreciated that other medical treatment devices can also be used. The injectable detecting system 12 can communicate wirelessly with the external devices 38 in a variety of ways including but not limited to, a public or proprietary communication standard and the like. The injectable detecting system 12 can be configured to serve as a communication hub for multiple medical devices, coordinating sensor data and therapy delivery while transmitting and receiving data from the remote monitoring system 18.

In one embodiment, the injectable detecting system 12 coordinate data sharing between the external systems 38 allowing for sensor integration across devices. The coordination of the injectable detecting system 12 provides for new pacing, sensing, defibrillation vectors, and the like.

In one embodiment, the processor 20 is included in the monitoring unit 22 and the external device 38 is in direct communication with the monitoring unit 22.

In another embodiment, illustrated in FIG. 7, a notification device 42 is coupled to the injectable detecting system 12 and the remote monitoring system 18. The notification device 42 is configured to provide notification when values received from the sensors 14 are not within acceptable physiological ranges. The notification device 42 can be at the remote monitoring system 18 or at the monitoring unit 22 that is part of the injectable detecting system 12. A variety of notification devices 42 can be utilized, including but not limited to, a visible patient indicator, an audible alarm, an emergency medical service notification, a call center alert, direct medical provider notification and the like. The notification device 42 provides notification to a variety of different entities, including but not limited to, the patient, a caregiver, the remote monitoring system, a spouse, a family member, a medical provider, from one device to another device such as the external device 38, and the like.

Notification can be according to a preset hierarchy. By way of illustration, and without limitation, the preset hierarchy can be, patient notification first and medical provider second, patient notification second and medical provider first, and the like. Upon receipt of a notification, a medical provider, the remote monitoring system 18, or a medical treatment device can trigger a high-rate sampling of physiological parameters for alert verification.

The system 10 can also include an alarm 46, that can be coupled to the notification device 42, for generating a human perceptible signal when values received from the sensors 14 are not within acceptable physiological ranges. The alarm 46 can trigger an event to render medical assistance to the patient, provide notification as set forth above, continue to monitor, wait and see, and the like.

When the values received from the sensors 14 are not within acceptable physiological ranges the notification is provided to at least one of, the patient, a spouse, a family member, a caregiver, a medical provider and from one device to another device, to allow for therapeutic intervention to prevent decompensation.

In another embodiment, the injectable detecting system 12 can switch between different modes, wherein the modes are selected from at least one of, a stand alone mode with communication directly with the remote monitoring system 18, communication with an implanted device, communication with a single implanted device, coordination between different devices (external systems) coupled to the plurality of sensors and different device communication protocols.

By way of illustration, and without limitation, the patient can be a congestive heart failure patient. Heart failure status is determined by a weighted combination change in sensor outputs and be determined by a number of different means, including but not limited to, (i) when a rate of change of at least two sensor outputs is an abrupt change in the sensor outputs as compared to a change in the sensor outputs over a longer period of time, (ii) by a tiered combination of at least a first and a second sensor output, with the first sensor output indicating a problem that is then verified by at least a second sensor output, (iii) by a variance from a baseline value of sensor outputs, and the like. The baseline values can be defined in a look up table.

In another embodiment, heart failure status is determined using three or more sensors by at least one of, (i) when the first sensor output is at a value that is sufficiently different from a baseline value, and at least one of the second and third sensor outputs is at a value also sufficiently different from a baseline

value to indicate heart failure status, (ii) by time weighting the outputs of the first, second and third sensors, and the time weighting indicates a recent event that is indicative of the heart failure status and the like.

In one embodiment, the wireless communication device **16** can include a, modem, a controller to control data supplied by the injectable detecting system **12**, serial interface, LAN or equivalent network connection and a wireless transmitter. Additionally, the wireless communication device **16** can include a receiver and a transmitter for receiving data indicating the values of the physiological event detected by the plurality of sensors, and for communicating the data to the remote monitoring system **18**. Further, the wireless communication device **16** can have data storage for recording the data received from the injectable detecting system **12** and an access device for enabling access to information recording in the data storage from the remote monitoring system **18**.

In various embodiments, the remote monitoring system **18** can include a, receiver, a transmitter and a display for displaying data representative of values of the one physiological event detected by the injectable detecting system **12**. The remote monitoring system can also include a, data storage mechanism that has acceptable ranges for physiological values stored therein, a comparator for comparing the data received from the injectable detecting system **12** with the acceptable ranges stored in the data storage device and a portable computer. The remote monitoring system **18** can be a portable unit with a display screen and a data entry device for communicating with the wireless communication device **16**.

Referring now to FIG. **8**, for each sensor **14**, a sensor lead **112** and **114** conveys signals from the sensor **14** to the monitoring unit **22** at the injectable detecting system **12**, or through the wireless communication device **16** to the remote monitoring system **18**.

In one embodiment, each signal from a sensor **14** is first passed through a low-pass filter **116**, at the injectable detecting system **12** or at the remote monitoring system **18**, to smooth the signal and reduce noise. The signal is then transmitted to an analog-to-digital converter **118A**, which transforms the signals into a stream of digital data values that can be stored in a digital memory **118B**. From the digital memory **118B**, data values are transmitted to a data bus **120**, along which they are transmitted to other components of the circuitry to be processed and archived. From the data bus **120**, the digital data can be stored in a non-volatile data archive memory. The digital data can be transferred via the data bus **120** to the processor **20**, which processes the data based in part on algorithms and other data stored in a non-volatile program memory.

The injectable detecting system **12** can also include a power management module **122** configured to power down certain components of the system, including but not limited to, the analog-to-digital converters **118A** and **124**, digital memories **118B** and the non-volatile data archive memory and the like, between times when these components are in use. This helps to conserve battery power and thereby extend the useful life. Other circuitry and signaling modes may be devised by one skilled in the art.

As can be seen in FIG. **9**, a control unit **126** is included at the detecting system **12**, the remote monitoring system **18**, or at both locations.

In one embodiment, the control unit **126** can be a micro-processor, for example, a Pentium or 486 processor. The control unit **126** can be coupled to the sensors **14** directly at the injectable detecting system **12**, indirectly at the injectable detecting system **12** or indirectly at the remote monitoring

system **18**. Additionally the control unit **126** can be coupled to one or more devices, for example, a blood pressure monitor, cardiac rhythm management device, scale, a device that dispenses medication, a device that can indicate the medication has been dispensed, and the like.

The control unit **126** can be powered by AC inputs which are coupled to internal AC/DC converters **134** that generate multiple DC voltage levels. After the control unit **126** has collected the patient data from the sensors **14**, the control unit **126** encodes the recorded patient data and transmits the patient data through the wireless communication device **16** to transmit the encoded patient data to a wireless network storage unit **128** at the remote monitoring system **18**, as shown in FIG. **10**. In another embodiment, wireless communication device **16** transmits the patient data from the injectable detecting system **12** to the control unit **126** when it is at the remote monitoring system **18**.

Every time the control unit **126** plans to transmit patient data to a main data collection station **130**, located at the remote monitoring system **18**, the control unit **126** attempts to establish a communication link. The communication link can be wireless, wired, or a combination of wireless and wired for redundancy, e.g., the wired link checks to see if a wireless communication can be established. If the wireless communication link **16** is available, the control unit **126** transmits the encoded patient data through the wireless communication device **16**. However, if the wireless communication device **16** is not available for any reason, the control unit **126** waits and tries again until a link is established.

Referring now to FIG. **11**, one embodiment of an internal structure of a main data collection station **130**, at the remote monitoring system **18**, is illustrated. The patient data can be transmitted by the remote monitoring system **18** by either the wireless communication device **16** or conventional modem to the wireless network storage unit **128**. After receiving the patient data, the wireless network storage unit **128** can be accessed by the main data collection station **130**. The main data collection station **130** allows the remote monitoring system **18** to monitor the patient data of numerous patients from a centralized location without requiring the patient or a medical provider to physically interact with each other.

The main data collection station **130** can include a communications server **136** that communicates with the wireless network storage unit **128**. The wireless network storage unit **128** can be a centralized computer server that includes a unique, password protected mailbox assigned to and accessible by the main data collection station **130**. The main data collection station **130** contacts the wireless network storage unit **128** and downloads the patient data stored in a mailbox assigned to the main data collection station **130**.

Once the communications server **136** has formed a link with the wireless network storage unit **128**, and has downloaded the patient data, the patient data can be transferred to a database server **138**. The database server **138** includes a patient database **140** that records and stores the patient data of the patients based upon identification included in the data packets sent by each of the monitoring units **22**. For example, each data packet can include an identifier.

Each data packet transferred from the remote monitoring system **18** to the main data collection station **130** does not have to include any patient identifiable information. Instead, the data packet can include the serial number assigned to the specific injectable detecting system **12**. The serial number associated with the detecting system **12** can then be correlated to a specific patient by using information stored on the patient database **138**. In this manner, the data packets transferred through the wireless network storage unit **128** do not include

any patient-specific identification. Therefore, if the data packets are intercepted or improperly routed, patient confidentiality can not be breached.

The database server **138** can be accessible by an application server **142**. The application server **142** can include a data adapter **144** that formats the patient data information into a form that can be viewed over a conventional web-based connection. The transformed data from the data adapter **144** can be accessible by proprietary application software through a web server **146** such that the data can be viewed by a workstation **148**. The workstation **148** can be a conventional personal computer that can access the patient data using proprietary software applications through, for example, HTTP protocol, and the like.

The main data collection station further can include an escalation server **150** that communicates with the database server **138**. The escalation server **150** monitors the patient data packets that are received by the database server **138** from the monitoring unit **22**. Specifically, the escalation server **150** can periodically poll the database server **138** for unacknowledged patient data packets. The patient data packets are sent to the remote monitoring system **18** where the processing of patient data occurs. The remote monitoring system **18** communicates with a medical provider in the event that an alert is required. The escalation server **150** can be programmed to automatically deliver alerts to a specific medical provider if an alarm message has not been acknowledged within a selected time period after receipt of the data packet.

The escalation server **150** can be configured to generate the notification message to different people by different modes of communication after different delay periods and during different time periods.

The main data collection station **130** can include a batch server **152** connected to the database server **138**. The batch server **152** allows an administration server **154** to have access to the patient data stored in the patient database **140**. The administration server **154** allows for centralized management of patient information and patient classifications.

The administration server **154** can include a batch server **156** that communicates with the batch server **152** and provides the downloaded data to a data warehouse server **158**. The data warehouse server **158** can include a large database **160** that records and stores the patient data.

The administration server **154** can further include an application server **162** and a maintenance workstation **164** that allow personnel from an administrator to access and monitor the data stored in the database **160**.

The data packet utilized in the transmission of the patient data can be a variable length ASCII character packet, or any generic data formats, in which the various patient data measurements are placed in a specific sequence with the specific readings separated by commas. The control unit **126** can convert the readings from each sensor **14** into a standardized sequence that forms part of the patient data packet. In this manner, the control unit **126** can be programmed to convert the patient data readings from the sensors **14** into a standardized data packet that can be interpreted and displayed by the main data collection station **130** at the remote monitoring system **18**.

Referring now to the flow chart of FIG. **12**, if an external device **38** fails to generate a valid reading, as illustrated in step A, the control unit **126** fills the portion of the patient data packet associated with the external device **38** with a null indicator. The null indicator can be the lack of any characters between commas in the patient data packet. The lack of characters in the patient data packet can indicate that the patient was not available for the patient data recording. The null

indicator in the patient data packet can be interpreted by the main data collection station **130** at the remote monitoring system **18** as a failed attempt to record the patient data due to the unavailability of the patient, a malfunction in one or more of the sensors **14**, or a malfunction in one of the external devices **38**. The null indicator received by the main data collection station **130** can indicate that the transmission from the injectable detecting system **12** to the remote monitoring system **18** was successful. In one embodiment, the integrity of the data packet received by the main data collection station **130** can be determined using a cyclic redundancy code, CRC-16, check sum algorithm. The check sum algorithm can be applied to the data when the message can be sent and then again to the received message.

After the patient data measurements are complete, the control unit **126** displays the sensor data, including but not limited to blood pressure cuff data and the like, as illustrated by step B. In addition to displaying this data, the patient data can be placed in the patient data packet, as illustrated in step C.

As previously described, the system **10** can take additional measurements utilizing one or more auxiliary or external devices **38** such as those mentioned previously. Since the patient data packet has a variable length, the auxiliary device patient information can be added to the patient data packet being compiled by the remote monitoring unit **22** during patient data acquisition period being described. Data from the external devices **38** is transmitted by the wireless communication device **16** to the remote monitoring system **18** and can be included in the patient data packet.

If the remote monitoring system **18** can be set in either the auto mode or the wireless only mode, the remote monitoring unit **22** can first determine if there can be an internal communication error, as illustrated in step D.

A no communication error can be noted as illustrated in step E. If a communication error is noted the control unit **126** can proceed to wireless communication device **16** or to a conventional modem transmission sequence, as will be described below. However, if the communication device is working, the control unit **126** can transmit the patient data information over the wireless network **16**, as illustrated in step F. After the communication device has transmitted the data packet, the control unit **126** determines whether the transmission was successful, as illustrated in step G. If the transmission has been unsuccessful only once, the control unit **126** retries the transmission. However, if the communication device has failed twice, as illustrated in step H, the control unit **126** proceeds to the conventional modem process if the remote monitoring unit **22** was configured in an auto mode.

When the control unit **126** is at the injectable detecting system **12**, and the control unit **126** transmits the patient data over the wireless communication device **16**, as illustrated in step I, if the transmission has been successful, the display of the remote monitoring unit **22** can display a successful message, as illustrated in step J. However, if the control unit **126** determines in step K that the communication of patient data has failed, the control unit **126** repeats the transmission until the control unit **126** either successfully completes the transmission or determines that the transmission has failed a selected number of times, as illustrated in step L. The control unit **126** can time out the and a failure message can be displayed, as illustrated in steps M and N. Once the transmission sequence has either failed or successfully transmitted the data to the main data collection station, the control unit **126** returns to a start program step O.

As discussed previously, the patient data packets are first sent and stored in the wireless network storage unit **128**. From

there, the patient data packets are downloaded into the main data collection station 130. The main data collection station 130 decodes the encoded patient data packets and records the patient data in the patient database 140. The patient database 140 can be divided into individual storage locations for each patient such that the main data collection station 130 can store and compile patient data information from a plurality of individual patients.

A report on the patient's status can be accessed by a medical provider through a medical provider workstation that is coupled to the remote monitoring system 18. Unauthorized access to the patient database can be prevented by individual medical provider usernames and passwords to provide additional security for the patient's recorded patient data.

The main data collection station 130 and the series of workstations 148 allow the remote monitoring system 18 to monitor the daily patient data measurements taken by a plurality of patients reporting patient data to the single main data collection station 130. The main data collection station 130 can be configured to display multiple patients on the display of the workstations 148. The internal programming for the main data collection station 130 can operate such that the patients are placed in a sequential top-to-bottom order based upon whether or not the patient can be generating an alarm signal for one of the patient data being monitored. For example, if one of the patients monitored by monitoring system 130 has a blood pressure exceeding a predetermined maximum amount, this patient can be moved toward the top of the list of patients and the patient's name and/or patient data can be highlighted such that the medical personnel can quickly identify those patients who may be in need of medical assistance. By way of illustration, and without limitation, the following paragraphs is a representative order ranking method for determining the order which the monitored patients are displayed:

Alarm Display Order Patient Status Patients are then sorted
 1 Medical Alarm Most alarms violated to least alarms violated, then oldest to newest
 2 Missing Data Alarm Oldest to newest
 3 Late Oldest to newest
 4 Reviewed Medical Alarms Oldest to newest
 5 Reviewed Missing Data Oldest to newest
 6 Reviewed Null Oldest to newest
 7 NDR Oldest to newest
 8 Reviewed NDR Oldest to newest

As listed in the above, the order of patients listed on the display can be ranked based upon the seriousness and number of alarms that are registered based upon the latest patient data information. For example, if the blood pressure of a single patient exceeds the tolerance level and the patient's heart rate also exceeds the maximum level, this patient will be placed above a patient who only has one alarm condition. In this manner, the medical provider can quickly determine which patient most urgently needs medical attention by simply identifying the patient's name at the top of the patient list. The order which the patients are displayed can be configurable by the remote monitoring system 18 depending on various preferences.

As discussed previously, the escalation server 150 automatically generates a notification message to a specified medical provider for unacknowledged data packets based on user specified parameters.

In addition to displaying the current patient data for the numerous patients being monitored, the software of the main data collection station 130 allows the medical provider to trend the patient data over a number of prior measurements in order to monitor the progress of a particular patient. In addition, the software allows the medical provider to determine whether or not a patient has been successful in recording their patient data as well as monitor the questions being asked by the remote monitoring unit 22.

As previously mentioned, the system 10 uses an intelligent combination of sensors to enhance detection and prediction capabilities. Electrocardiogram circuitry can be coupled to the sensors 14, or electrodes, to measure an electrocardiogram signal of the patient. An accelerometer can be mechanically coupled, for example adhered or affixed, to the sensors 14, adherent patch and the like, to generate an accelerometer signal in response to at least one of an activity or a position of the patient. The accelerometer signals improve patient diagnosis, and can be especially useful when used with other signals, such as electrocardiogram signals and impedance signals, including but not limited to, hydration respiration, and the like. Mechanically coupling the accelerometer to the sensors 14, electrodes, for measuring impedance, hydration and the like can improve the quality and/or usefulness of the impedance and/or electrocardiogram signals. By way of illustration, and without limitation, mechanical coupling of the accelerometer to the sensors 14, electrodes, and to the skin of the patient can improve the reliability, quality and/or accuracy of the accelerometer measurements, as the sensor 14, electrode, signals can indicate the quality of mechanical coupling of the patch to the patient so as to indicate that the device is connected to the patient and that the accelerometer signals are valid. Other examples of sensor interaction include but are not limited to, (i) orthopnea measurement where the breathing rate is correlated with posture during sleep, and detection of orthopnea, (ii) a blended activity sensor using the respiratory rate to exclude high activity levels caused by vibration (e.g. driving on a bumpy road) rather than exercise or extreme physical activity, (iii) sharing common power, logic and memory for sensors, electrodes, and the like.

While the invention is susceptible to various modifications and alternative constructions, certain illustrated embodiments thereof are shown in the drawings and have been described above in detail. It should be understood, however, that there is no intention to limit the invention to the specific form or forms disclosed, but on the contrary, the intention is to cover all modifications, alternative constructions, and equivalents falling within the spirit and scope of the invention.

What is claimed is:

1. An injectable device for use in physiological monitoring, comprising:

a plurality of sensors axially spaced along a body that provide an indication of at least one physiological event of a patient;

a monitoring unit within the body coupled to the plurality of sensors configured to receive data from the plurality of sensors and create processed patient data;

a power source within the body coupled to the monitoring unit; and

a communication antenna external to the body coupled to the monitoring unit configured to transfer data to/from other devices.

2. The device of claim 1, wherein the monitoring unit includes a processor.

3. The device of claim 2, wherein the processor includes program instructions for evaluating values received from the sensors with respect to acceptable physiological ranges for each value received by the processor and determine variances.

4. The device of claim 1, wherein the monitoring unit includes logic resources that determine heart failure status and predict impending decompensation.

5. The device of claim 1, wherein the monitoring unit is configured to perform one or more of, data compression, prioritizing of sensing by a sensor, cycling sensors, monitor-

ing all or some of sensor data by all or a portion of the sensors, sensing by the sensors in real time, noise blanking to provide that sensor data is not stored if a selected noise level is determined, low-power of battery caching and decimation of old sensor data.

6. The device of claim 1, wherein the monitoring unit includes a notification device configured to provide notification when values received from the plurality of sensors are not within acceptable physiological ranges.

7. The device of claim 1, wherein the monitoring unit is configured to serve as a communication hub for multiple medical devices, coordinating sensor data and therapy delivery while transmitting and receiving data from a remote monitoring system.

8. The device of claim 1, wherein the monitoring unit is configured to deactivate selected sensors to reduce redundancy.

9. The device of claim 1, wherein each of a sensor is selected from at least one of, bioimpedance, heart rate, heart rhythm, HRV, HRT, heart sounds, respiratory sounds, respiratory rate and respiratory rate variability, blood pressure, activity, posture, wake/sleep, orthopnea, temperature, heat flux and an accelerometer.

10. The device of claim 1, wherein each of a sensor is an activity sensor selected from at least one of, ball switch, accelerometer, minute ventilation, HR, bioimpedance noise, skin temperature/heat flux, BP, muscle noise and posture.

11. The device of claim 1, wherein the sensors are made of at least a material selected from, silicone, polyurethane, Nitinol, titanium, a biocompatible material, ceramics and a bioabsorbable material.

12. The system of claim 1, wherein at least a portion of sensors of the plurality of sensors have an insulative material selected from, PEEK, ETFE, PTFE, and polyimide, silicon, polyurethane.

13. The device of claim 1, wherein at least a portion of sensors of the plurality of sensors have openings or an absorbent material configured to sample a hydration level or electrolyte level in a surrounding tissue site of the plurality of sensors.

14. The device of claim 1, wherein the plurality of sensors includes current delivery electrodes and sensing electrodes.

15. The device of claim 1, wherein the outputs of the plurality of sensors is used to calculate and monitor blended indices.

16. The device of claim 15, wherein the blended indices include at least one of, heart rate (HR) or respiratory rate (RR) response to activity, HR/RR response to posture change, HR+RR, HR/RR+bioimpedance, and/or minute ventilation/accelerometer.

17. The device of claim 1, wherein the body and antenna are injectable in the patient by at least one of, catheter delivery, blunt tunneling, insertion with a needle, by injection, with a gun or syringe device with a stiffening wire stylet, guidewire, or combination of stylet or guidewire with a catheter.

18. The device of claim 1, wherein the body is flexible.

19. The device of claim 1, wherein at least a portion of the body has a drug eluting coating.

20. The device of claim 1, wherein the power source comprises a rechargeable battery transcutaneously chargeable with an external unit.

21. The device of claim 1, wherein the antenna is an expanding antenna expandable from a first compressed shape to a second expanded shape.

22. The device of claim 1, wherein the plurality of sensors includes two current delivery electrodes and two sensing electrodes, and the monitoring unit is configured to measure bioimpedance using the two currently delivery electrodes and the two sense electrodes.

23. An injectable device for use in physiological monitoring, comprising:

a plurality of electrodes axially spaced along a flexible injectable body, the electrodes comprising two current delivery electrodes and two sense electrodes for measuring bioimpedance;

a monitoring unit within the body coupled to the plurality of electrodes configured receive an output of the sense electrodes and determine the bioimpedance from the output;

a power source within the body coupled to the monitoring unit; and

a communication antenna external to the body coupled to the monitoring unit configured to transfer data to/from other devices.

24. The injectable device of claim 23, wherein the antenna is an expanding antenna expandable from a first compressed shape to a second expanded shape.

25. The injectable device of claim 23, wherein the monitoring unit is further configured to, based at least in part on bioimpedance readings taken over a period of time, predict impending decompensation in a patient.

26. The injectable device of claim 25, wherein the monitoring unit is further configured to wirelessly communicate an indication of the decompensation prediction to another device.

* * * * *

专利名称(译)	用于生理监测的可注射装置		
公开(公告)号	US8684925	公开(公告)日	2014-04-01
申请号	US12/209430	申请日	2008-09-12
[标]申请(专利权)人(译)	科文迪斯有限公司		
申请(专利权)人(译)	CORVENTIS INC.		
当前申请(专利权)人(译)	CORVENTIS INC.		
[标]发明人	MANICKA YATHEENDHAR D AMURTHUR BADRI BLY MARK JAMES KRISTOFER LIBBUS IMAD MAZAR SCOTT WANG JERRY		
发明人	MANICKA, YATHEENDHAR D. AMURTHUR, BADRI BLY, MARK JAMES, KRISTOFER LIBBUS, IMAD MAZAR, SCOTT WANG, JERRY		
IPC分类号	A61B5/145 A61B5/00		
CPC分类号	A61B5/07 A61N1/37205 A61B2560/0214 A61B5/14503 A61B2562/16 A61B5/0031 A61B2560/0468 A61B5/7232 A61B5/076 A61B5/02055 A61B5/053 A61B5/4875 A61B5/7282		
代理机构(译)	KILPATRICK TOWNSEND & STOCKTON LLP		
优先权	61/055666 2008-05-23 US 60/972537 2007-09-14 US 60/972329 2007-09-14 US 60/972354 2007-09-14 US 60/972336 2007-09-14 US		
其他公开文献	US20090076348A1		
外部链接	Espacenet USPTO		

摘要(译)

提供一种可注射检测装置，用于生理监测。该装置包括沿身体轴向间隔开的多个传感器，其提供患者的至少一个生理事件的指示，身体内的监测单元耦合到多个传感器，所述多个传感器被配置为从多个传感器接收数据并且创建处理的患者的数据，连接到监视单元的体内的电源，以及连接到监视单元的体外部的通信天线，被配置为向/从其他设备传输数据。

