



US 20090216093A1

(19) **United States**

(12) **Patent Application Publication**  
**Sebastian et al.**

(10) **Pub. No.: US 2009/0216093 A1**  
(43) **Pub. Date: Aug. 27, 2009**

(54) **SYSTEM AND METHOD FOR REMOTELY MONITORING PHYSIOLOGICAL FUNCTIONS**

(60) Provisional application No. 60/611,295, filed on Sep. 21, 2004, provisional application No. 60/651,989, filed on Feb. 14, 2005.

(75) Inventors: **Richard L. Sebastian**, Frederick, MD (US); **Kendall L. Belsley**, Falls Church, VA (US)

**Publication Classification**

(51) **Int. Cl.**  
*A61B 5/00* (2006.01)  
*A61B 6/00* (2006.01)  
(52) **U.S. Cl.** ..... **600/301; 600/476**

Correspondence Address:  
**PILLSBURY WINTHROP SHAW PITTMAN, LLP**  
**P.O. BOX 10500**  
**MCLEAN, VA 22102 (US)**

(57) **ABSTRACT**

A system and method for remotely monitoring an individual, in accordance with some embodiments of the invention. More particularly, one or more physiological functions and/or physical activities of the individual may be monitored. In order to monitor the individual, a range to, and/or a range rate (i.e., velocity) of, one or more points on one or more surfaces of the individual (e.g., skin, clothing, lips, etc.) may be determined over time. Based on the determinations of the range and/or range rate of the points on the surfaces of the individual, the one or more physiological functions and/or physical activities of the individual may be monitored. This may enable the physiological functions and/or physical activities to be monitored remotely from the individual without access or proximity to the individual.

(73) Assignee: **Digital Signal Corporation**

(21) Appl. No.: **12/393,537**

(22) Filed: **Feb. 26, 2009**

**Related U.S. Application Data**

(63) Continuation of application No. 11/230,546, filed on Sep. 21, 2005, now Pat. No. 7,507,203.

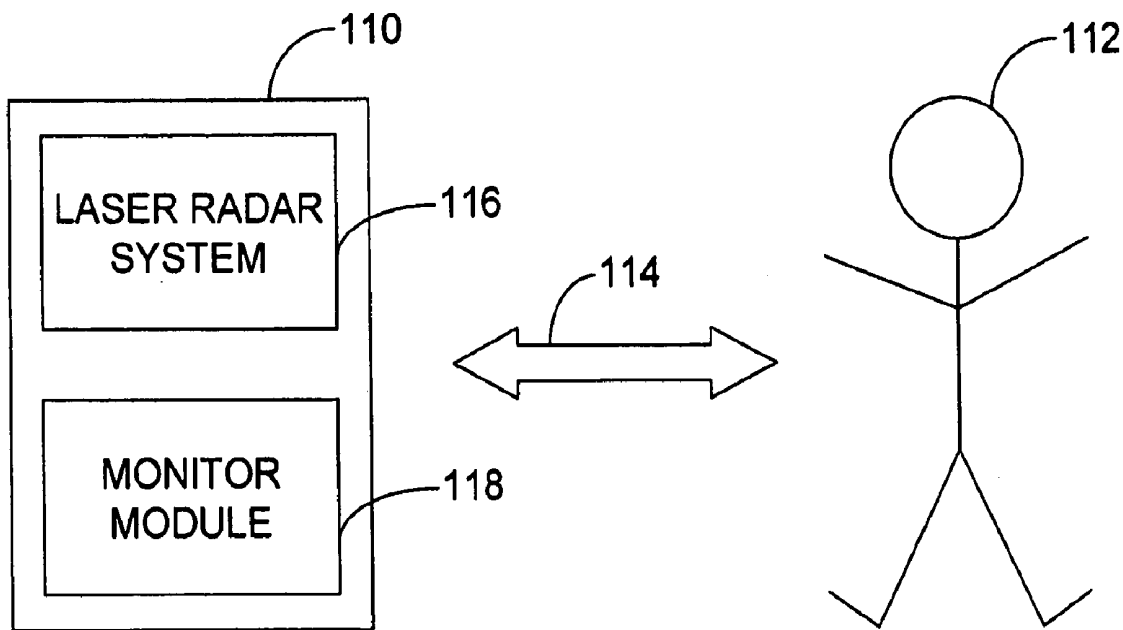

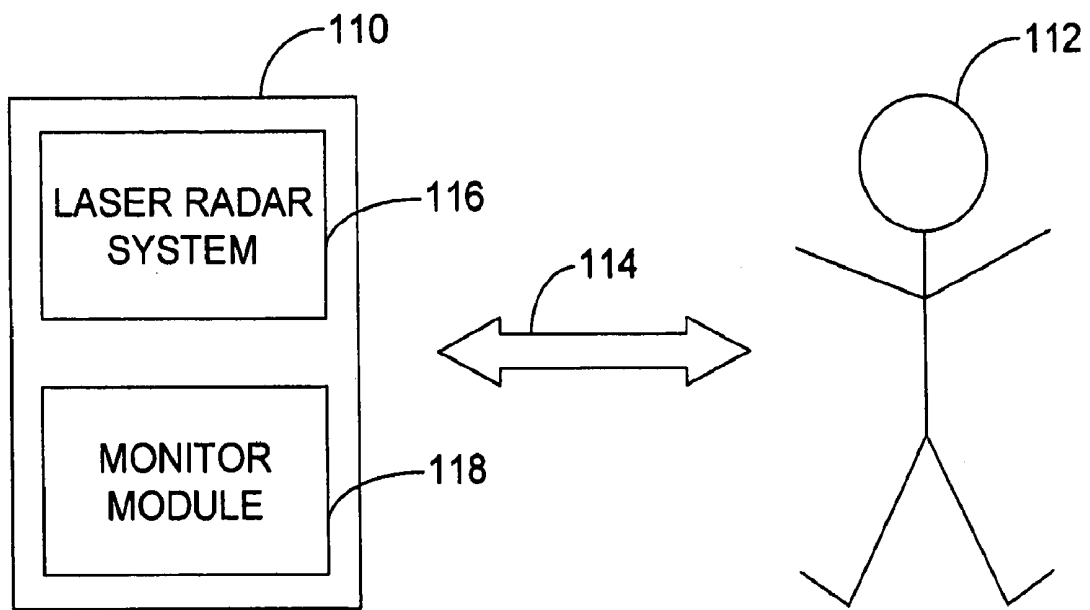

FIG. 1



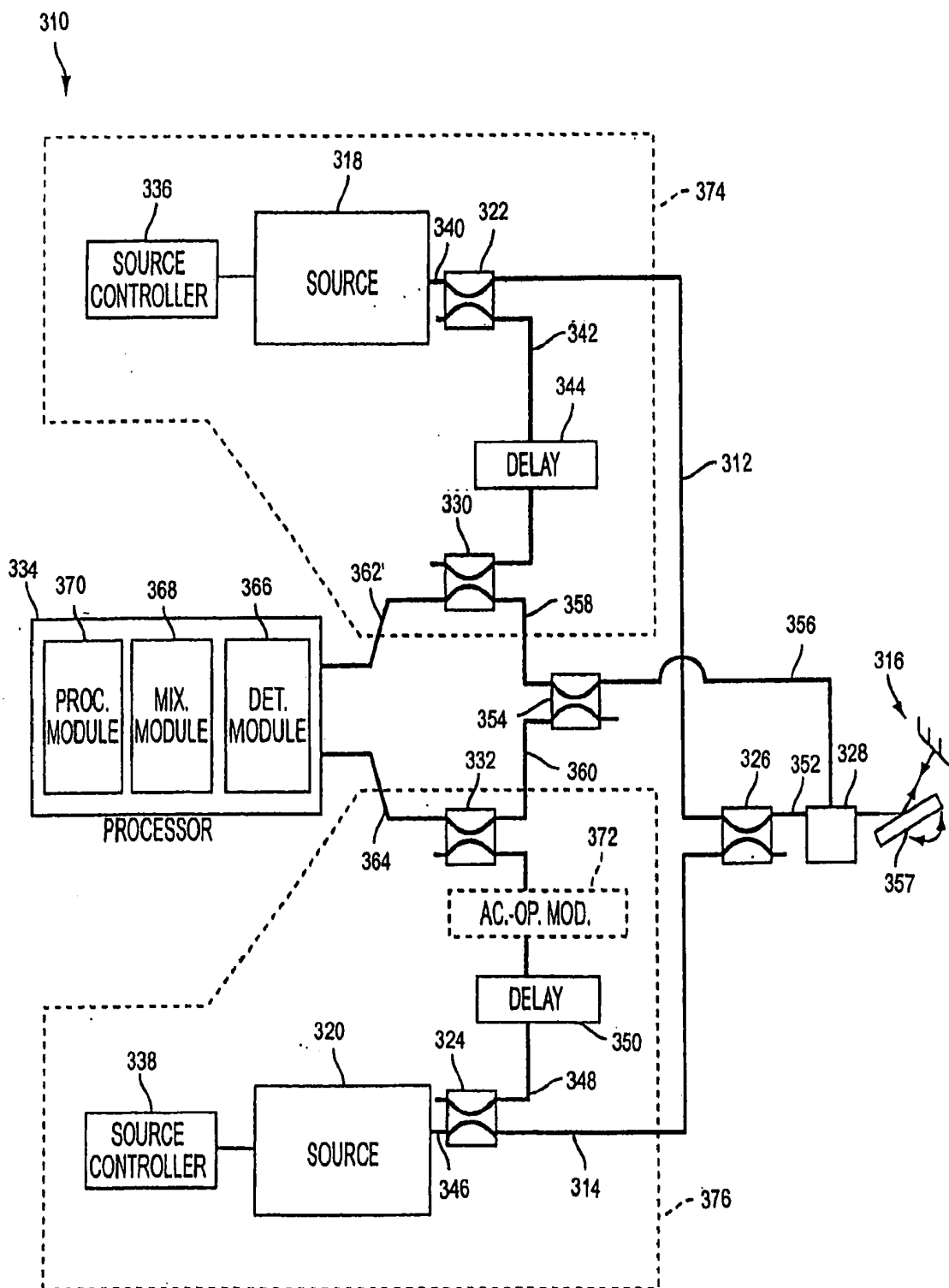

FIG. 3

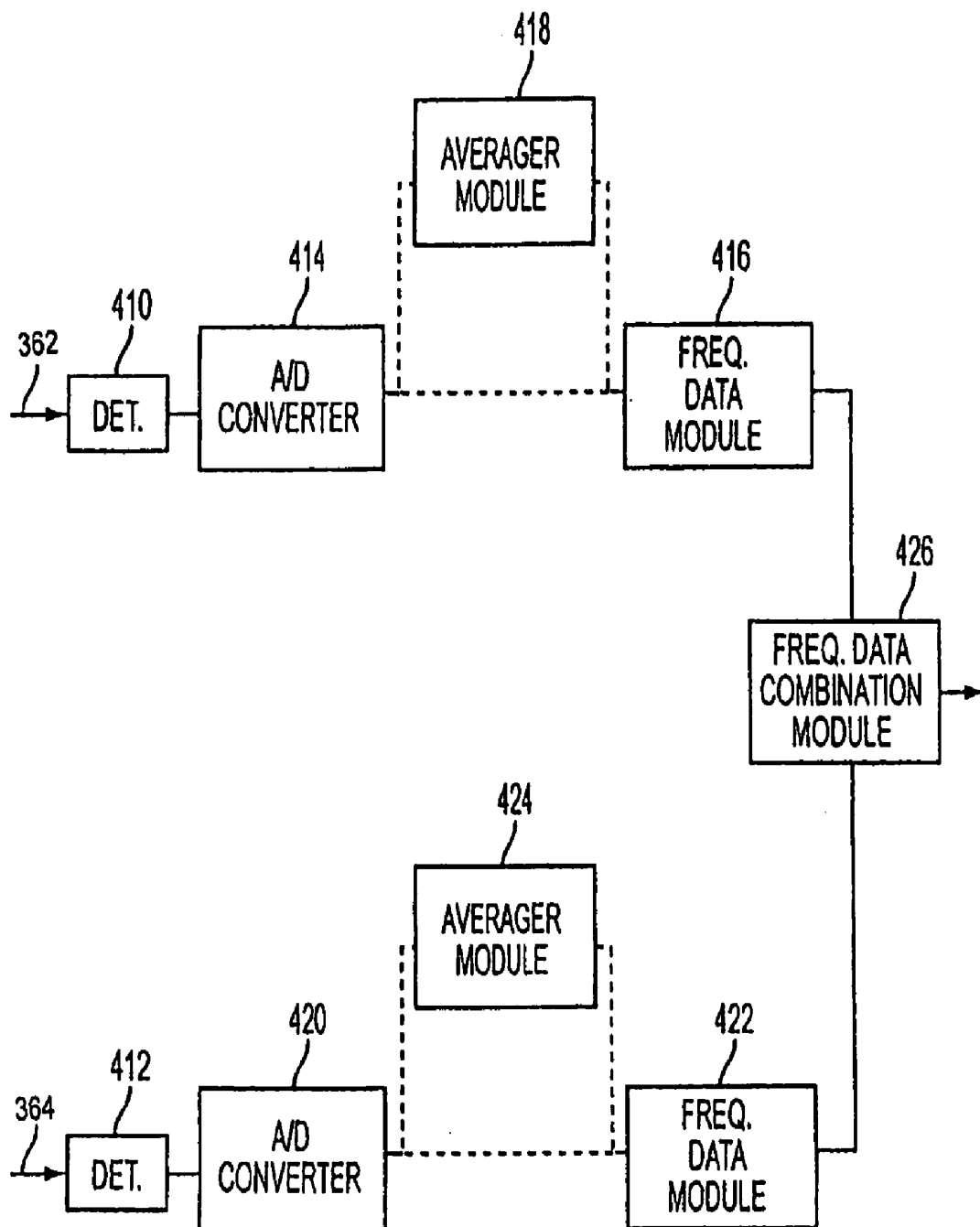

FIG. 4

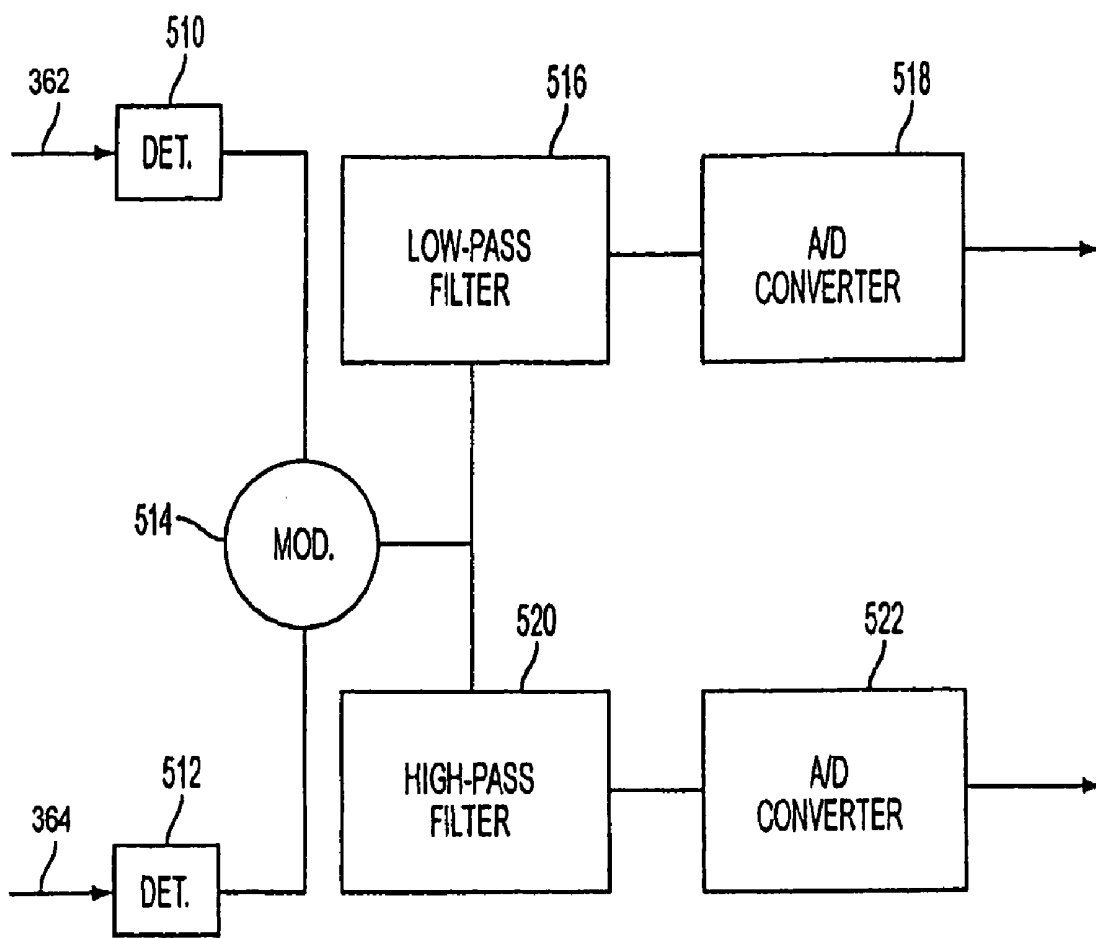

FIG. 5

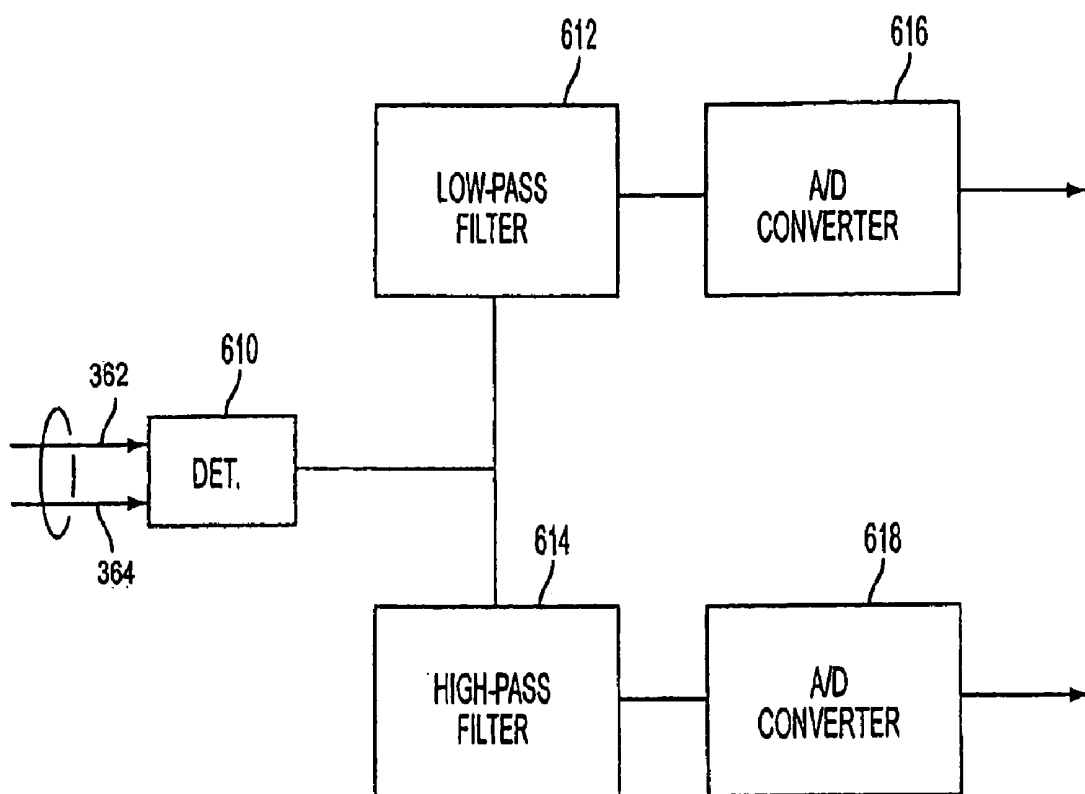

FIG. 6

## SYSTEM AND METHOD FOR REMOTELY MONITORING PHYSIOLOGICAL FUNCTIONS

### RELATED APPLICATIONS

[0001] This application claims priority from U.S. Provisional Patent Application No. 60/611,295, entitled "System and Method for Using a Coherent Laser Radar Instrument for Remotely Monitoring Cardiovascular and Breathing Signals," filed Sep. 21, 2004, and U.S. Provisional Patent Application No. 60/651,989, entitled "Chirped Coherent Laser Radar System and Method," filed Feb. 14, 2005, both of which are incorporated herein by reference.

### FIELD OF THE INVENTION

[0002] The invention relates to systems and methods for remotely monitoring physiological functions and/or physical activities of an individual.

### BACKGROUND OF THE INVENTION

[0003] Various devices for monitoring one or more physiological functions of a subject are known. Conventional devices may enable one or more cardiovascular functions, one or more respiratory function, or other physiological functions to be monitored. Cardiovascular functions may include a heart rate, a heart rate variability, a pulse transit time, a pulse shape, and/or other cardiovascular functions. Respiratory functions may include a respiration rate, a respiratory effort, and/or other respiratory functions.

[0004] Generally, in order to monitor physiological functions of a subject, conventional devices operate typically require physical proximity and/or access to the subject. For example, cardiovascular functions may be monitored by contact (e.g., monitoring the flow of blood through blood vessels and/or arteries close to the skin of the subject, monitoring heart beats by the rise and fall of the chest, etc.), by sound (e.g., through a stethoscope, etc.), or by another mechanism that requiring physical proximity and/or access with the subject. Respiratory functions may be monitored, for instance, by measuring a flow rate of gas proximate to an airway of the subject, or by another mechanism requiring physical proximity and/or access to the subject.

[0005] The physical proximity and/or access to the subject typically required by conventional devices for monitoring physiological function may be intrusive and/or may be uncomfortable, which may, in some circumstances, preclude monitoring a subject. For example, monitoring the subject without alerting the subject may not be possible. In other cases, monitoring the subject may impair an ability of the subject to rest while being monitored. Other drawbacks with conventional devices are known.

[0006] Various measuring devices for measuring linear distances using one or more laser radars are known. Such measuring devices may generate information related to a distance or range of a target from the measuring device and/or a velocity, or range rate, of the target relative to the measuring device. This range and range rate information may be useful in a variety of settings. For the purposes of this application the

term range rate refers to the rate of change in the range between the target and the measuring device.

### SUMMARY

[0007] One aspect of various embodiments of the invention may relate to a system and method for remotely monitoring an individual, in accordance with some embodiments of the invention. More particularly, one or more physiological functions and/or physical activities of the individual may be monitored. In order to monitor the individual, a range to, and/or a range rate (i.e., velocity) of, one or more points on one or more surfaces of the individual (e.g., skin, clothing, lips, etc.) may be determined over time. Based on the determinations of the range and/or range rate of the points on the surfaces of the individual, the one or more physiological functions and/or physical activities of the individual may be monitored. This may enable the physiological functions and/or physical activities to be monitored remotely from the individual without access or proximity to the individual. This may enable the monitoring of the physiological functions and/or physical activities of the individual to be accomplished in a manner that may be indiscernible to the individual.

[0008] In some embodiments of the invention, a laser radar system may direct a beam of electromagnetic radiation toward the individual to be incident onto the individual at a point on a surface of the individual. Some or all of the beam of radiation directed to the point on the surface of the individual may be reflected (and/or scattered) by the surface, and may then be received back into the laser radar system. Based on one or more aspects of the radiation (e.g., frequency, phase, intensity, etc.) prior to emission and/or subsequent to reflection, the laser radar system may determine one or both of the range and the range rate of the point on the surface with respect to laser radar system.

[0009] According to various embodiments of the invention, the laser radar system may make a plurality of determinations of ranges and/or range rates of one or more points on one or more surfaces of the individual (e.g., at a periodic rate) over a period of time. General trends in the determined ranges and/or range rates over the period of time may be implemented by a monitor module to estimate body (or body member) motion exhibited by the individual, while residual deviations from the perceived trend(s) may be used to estimate surface vibrations of the surface(s) of the individual. The observed surface vibrations may include one or both of short period vibrations and long period vibrations. Based on the estimated body motion and/or surface vibrations, one or more physiological functions and/or physical activities of the individual may be monitored by monitor module.

[0010] In some embodiments, ranges and/or range rates of a plurality of points on one or more surfaces of the individual may be determined by the laser radar system. For example, the laser radar system may scan the beam of radiation during emission such that the radiation is scanned across the individual in a raster. In such embodiments, the laser radar system may monitor one or more surface areas on the individual (e.g., a chest area, a neck area, a wrist area, a facial area, etc.), or the laser radar system may monitor the entire surface of the individual exposed on a line of sight to the laser radar system.

[0011] According to various embodiments of the invention, the physiological functions and/or physical activities of the individual monitored by the monitor module based on the estimations of body motion and/or surface vibrations of the individual may include one or more cardiovascular functions,

one or more respiratory function, other physiological functions, and other physical activities. Cardiovascular functions may include a heart rate, a heart rate variability, a pulse transit time, a pulse shape, and/or other cardiovascular functions. Respiratory functions may include a respiration rate, a respiratory effort, and/or other respiratory functions. Physical activities may include speaking, coughing, sneezing, walking, running, or other physical activities. In some instances, the physiological functions and/or physical activities may include one or more physiological functions which may be inferred from others of the physiological functions and/or physical activities. Examples of this may include, a vascular tone that may be inferred from a pulse transit time, and/or an autonomic tone that may be inferred from a pulse shape.

**[0012]** Another aspect of various embodiments of the invention may relate to a laser radar system that unambiguously detects a range of a target and a range rate at which the target is moving relative to the laser radar system. Another aspect of various embodiments of the invention may relate to a laser radar system that uses multiple laser radar sections to obtain multiple simultaneous measurements (or substantially so), whereby both range and range rate can be determined without various temporal effects introduced by systems employing single laser sections taking sequential measurements. In addition, other aspects of various embodiments of the invention may enable faster determination of the range and rate of the target, a more accurate determination of the range and rate of the target, and/or may provide other advantages.

**[0013]** In some embodiments of the invention, the implementation of such a laser radar system to monitor one or more points on a surface of an individual in order to monitor one or more physiological functions and/or physical activities of the individual may provide unambiguous determinations of ranges and the range rates of points on surface(s) of the individual, and may thereby enable enhanced monitoring of the one or more physiological functions and/or physical activities of the individual. For example, the unambiguous determination of the range and/or the range rate of the points on the surface of the individual may reduce an amount of noise in the determined ranges and/or range rates. Thus, the laser radar system may enhance the accuracy of the determinations of the ranges and/or range rates. Enhancing the accuracy of the determined ranges and/or range rates may enhance determinations that leverage the determined ranges and/or range rates to monitor physiological functions and/or physical activities of the individual. For example, determinations of general trends in the ranges and/or range rates that indicate body motion, and/or residual deviation(s) from the general trends that indicate of surface vibrations may be enhanced.

**[0014]** In some embodiments of the invention, the laser radar system may emit a first target beam and a second target beam toward a target. The first target beam and the second target beam may be reflected by the target back toward the laser radar system. The laser radar system may receive the reflected first target beam and second target beam, and may determine at least one of a range of the target from the laser radar system, and a range rate of the target. In some embodiments of the invention, the laser radar system may include a first laser radar section, a second laser radar section, and a processor.

**[0015]** In some embodiments of the invention, the first laser radar section may generate a first target beam and a first reference beam. The first target beam and the first reference

beam may be generated by a first laser source at a first frequency that may be modulated at a first chirp rate. The first target beam may be directed toward a measurement point on the target. The first laser radar section may combine one portion of the first target beam that may be directed towards, and reflected from, the target. Another portion of the first target beam, referred to as a local oscillator beam, may be directed over a path with a known or otherwise fixed path length. This may result in a combined first target beam.

**[0016]** According to various embodiments of the invention, the second laser radar section may be collocated and fixed with respect to the first laser radar section. More particularly, the relevant optical components for transmitting and receiving the respective laser beams are collocated and fixed. The second laser radar section may generate a second target beam and a second reference beam. The second target beam and the second reference beam may be generated by a second laser source at a second frequency that may be modulated at a second chirp rate. The second chirp rate may be different from the first chirp rate. This may facilitate one or more aspects of downstream processing, such as, signal discrimination, or other aspects of downstream processing. The second target beam may be directed toward the same measurement point on the target as the first target beam. The second laser radar section may combine one portion of the second target beam that may be directed towards, and reflected from, the target, and another portion of the second target beam that may be directed over a path with a known or otherwise fixed path length. This results in a combined second target beam.

**[0017]** According to various embodiments of the invention, the processor receives the first and second combined target beams and measures a beat frequency caused by a difference in path length between each of the respective reflected target beams and its corresponding local oscillator beam, and by any Doppler frequency shift created by target motion relative to the laser radar system. The beat frequencies may then be combined linearly to generate unambiguous determinations of the range and the range rate of the target, so long as the beat frequencies between each of the respective local oscillator beams and the its reflected target beam correspond to simultaneous (or substantially simultaneous) temporal components of the reflected target beams. Simultaneous (or substantially simultaneous) temporal components of the reflected target beams may include temporal components of the target beams that: 1) have been incident on substantially the same portion of the target, 2) have been impacted by similar transmission effects, 3) have been directed by a scanning optical element under substantially the same conditions, and/or share other similarities. The utilization of beat frequencies that correspond to simultaneous (or substantially simultaneous) temporal components of the reflected target beams for linear combination may effectively cancel any noise introduced into the data by environmental or other effects (see e.g. Equation (1)).

**[0018]** Since the combined target beams may be created by separately combining the first local oscillator beam and the second local oscillator beam with different target beams, or different portions of the same target beam, the first combined target beam and the second combined target beam may represent optical signals that might be present in two separate, but coincident, single source frequency modulated laser radar systems, just prior to final processing. For example, the combined target beams may represent optical signals produced by target interferometers in the single source systems.

[0019] According to various embodiments, the target beams may be directed to and/or received from the target on separate optical paths. In some embodiments, these optical paths may be similar but distinct. In other embodiments the first target beam and the second target beam may be coupled prior to emission to create a combined target beam that may be directed toward the target along a common optical path. In some embodiments, the target beam may be reflected by the target and may be received by the laser radar system along a reception optical path separate from the common optical path that directed the target beam toward the target. Such embodiments may be labeled "bistatic." Or, the combined target beam may be received by the laser radar system along the common optical path. These latter embodiments may be labeled "monostatic." Monostatic embodiments may provide advantages over their bistatic counterparts when operating with reciprocal optics. More particularly, monostatic embodiments of the invention are less affected by differential Doppler effects and distortion due to speckle, among other things. Differential Doppler effects are created, for example, by a scanning mirror that directs the target beam to different locations on a target. Since different parts of the mirror are moving at different velocities, different parts of the target beam experience different Doppler shifts, which may introduce errors into the range and or range rate measurements. These effects have been investigated and analyzed by Anthony Slotwinski and others, for example, in NASA Langley Contract No. NAS1-18890 (May 1991) Phase II Final Report, Appendix K, submitted by Digital Signal Corporation, 8003 Forbes Place, Springfield, Va. 22131, which is incorporated herein by reference in its entirety.

[0020] In some instances, the first laser source and the second laser source may generate electromagnetic radiation at a first carrier frequency and a second carrier frequency, respectively. The first carrier frequency may be substantially the same as the second carrier frequency. This may provide various enhancements to the laser radar system, such as, for example, minimizing distortion due to speckle, or other enhancements.

[0021] In some embodiments, the first laser source and the second laser source may provide electromagnetic radiation with highly linearized frequency chirp. To this end, the linearization of the electromagnetic radiation emitted by the first laser source and the second laser source may be calibrated on a frequent basis (e.g. each chirp), or in some embodiments continuously (or substantially so). This linearization of the frequency chirp of the electromagnetic radiation may provide enhanced range measurement accuracy, or other enhancements, over conventional systems in which linearization may occur at startup, when an operator notices degraded system performance, when the operator is prompted to initiate linearization based on a potential for degraded performance, or when one or more system parameters fall out of tolerance, etc. Frequent and/or automated linearization may reduce mirror differential Doppler noise effects during high speed scanning and may maximize the effectiveness of dual chirp techniques for canceling out these and other noise contributions to range estimates.

[0022] In some embodiments of the invention, the laser radar system may determine the range and the range rate of the target with an increased accuracy when the range of the target from the laser radar system falls within a set of ranges between a minimum range and a maximum range. When the range of the target does not fall within the set of ranges, the

accuracy of the laser radar system may be degraded. This degradation may be a result of the coherence length(s) of the first laser source and the second laser source, which is finite in nature. For example, the distance between the minimum range and the maximum range may be a function of the coherence length. The longer the coherence length of the first laser source and the second laser source, the greater the distance between the minimum range and the maximum range. Thus, increasing the coherence length of the first laser source and the second laser source may enhance range and range rate determinations by the laser radar system by providing the ability to make determinations over an enhanced set of ranges.

[0023] In some embodiments of the invention, one or both of the first laser source and the second laser source may implement a system and method for controllably chirping electromagnetic radiation from a radiation source. The system and method may enable electromagnetic radiation to be produced at a substantially linear chirp rate with a configurable period. In some embodiments, the radiation may include a single, frequency shifted, resonant mode.

[0024] In some embodiments of the invention, a system may include a radiation source, one or more optical elements that form an optical cavity, a frequency shifter, an optical switch and an optical amplifier. In some embodiments, the frequency shifter may be disposed within the optical cavity to receive electromagnetic radiation from the optical cavity, and to output a frequency shifted portion of the received electromagnetic radiation back to the optical cavity. The optical switch may be disposed within the optical cavity to receive electromagnetic radiation from the optical cavity. The optical switch may be controllable to either direct the received electromagnetic radiation away from the optical cavity, or to return the received electromagnetic radiation back to the optical cavity. In some instances, the optical switch may be controllable to couple radiation from the radiation source to the optical cavity while directing the received electromagnetic radiation away from the optical cavity, the radiation from the source being received at the optical switch at an initial frequency.

[0025] According to various embodiments of the invention, the optical cavity may be "filled" by directing radiation from the laser source, emitted at the initial frequency, into the optical cavity for a period of time that corresponds to the optical length of the optical cavity. In some embodiments, the radiation from the laser source may be directed into the optical cavity by the optical switch. While the electromagnetic radiation from the laser source is being directed in to the cavity, the optical switch may be controlled to direct radiation received by the optical switch away from the optical cavity, or "dumped" from the cavity. Once the cavity is "filled" (e.g., after the time period corresponding to the optical length of the optical cavity has passed) the flow of radiation from the laser source to the optical cavity may be halted. In some embodiment, the flow of radiation from the laser source to the optical cavity may be halted by powering down the laser source. In other embodiments, the flow of radiation from the laser source to the optical cavity may be halted by controlling the optical switch to dump the radiation from the laser source away from the optical cavity. The radiation injected into the optical cavity while the cavity was being filled, may be circulated within the cavity by the optical switch, which may be controlled to direct radiation received from the optical cavity back into the optical cavity.

**[0026]** In some embodiments of the invention, as the electromagnetic radiation is circulated within the optical cavity, the frequency of the radiation may be incrementally adjusted by the frequency shifter during each trip around the optical cavity. Through this periodic, incremental adjustment, the frequency of the radiation within the optical cavity may be chirped in a substantially linear manner. The rate at which the frequency of the electromagnetic radiation is chirped may be related to one or both of the incremental frequency adjustment applied by the frequency shifter and the optical length of the cavity. Thus, the rate at which the frequency of the radiation is chirped, may be controlled via one or both of these variables.

**[0027]** In some embodiments, a quality factor of the optical cavity may be degraded by various losses within the optical cavity. For example, radiation output from the optical cavity to a device may constitute a loss. Other losses may also be present, such as losses due to imperfections in the optical elements, or other parasitic losses. To combat the degradation of the quality factor, an optical amplifier may be disposed within the optical cavity. The optical amplifier may be selected or controlled to provide enough gain to radiation within the optical cavity to overcome the sum of the cavity losses so that a predetermined or controlled intensity of radiation output from the optical cavity may be maintained. The optical amplifier may also be selected based on one or more other characteristics, such as, for example, homogeneous line width, gain bandwidth, or other specifications.

**[0028]** In some embodiments of the invention, one of the chirp rates may be set equal to zero. In other words, one of the laser sources may emit radiation at a constant frequency. This may enable the laser source emitting at a constant frequency to be implemented with a simpler design, a small footprint, a lighter weight, a decreased cost, or other enhancements that may provide advantages to the overall system. In these embodiments, the laser radar section with chirp rate set equal to zero may be used to determine only the range rate of the target.

**[0029]** In some embodiments of the invention, the processor may linearly combine the first combined target beam and the second combined target beam digitally to generate the range signal and the range rate signal. For example, the processor may include a first detector and a second detector. The first detector may receive the first combined target beam and may generate a first analog signal that corresponds to the first combined target beam. The first analog signal may be converted to a first digital signal by a first converter. The processor may include a first frequency data module that may determine a first set of frequency data that corresponds to one or more frequency components of the first digital signal.

**[0030]** The second detector may receive the second combined target beam and may generate a second analog signal that corresponds to the second combined target beam. The second analog signal may be converted to a second digital signal by a second converter. The processor may include a second frequency data module that may determine a second set of frequency data that corresponds to one or more of frequency components of the second digital signal.

**[0031]** The first set of frequency data and the second set of frequency data may be received by a frequency data combination module. The frequency data combination module may generate a range rate signal and a range signal derived from the first set of frequency data and the second set of frequency data.

**[0032]** In other embodiments of the invention, the processor may mix the first combined target beam and the second combined target beam electronically to generate the range signal and the range rate signal. For example, the processor may include a modulator. The modulator may multiply the first analog signal generated by the first detector and the second analog signal generated by the second detector to create a combined analog signal. In such embodiments, the processor may include a first filter and a second filter that receive the combined analog signal. The first filter may filter the combined analog signal to generate a first filtered signal. The first filtered signal may be converted by a first converter to generate a range rate signal. The second filter may filter the combined analog signal to generate a second filtered signal. The second filtered signal may be converted by a second converter to generate a range signal.

**[0033]** According to other embodiments of the invention, the processor may mix the first combined target beam and the second combined target beam optically to generate the range signal and the range rate signal. For example, the processor may include a detector that receives the first combined target beam and the second combined target beam and generates a combined analog signal based on the detection of the first combined target beam and the second combined target beam. In such embodiments, the processor may include a first filter and a second filter that receive the combined analog signal. The first filter may filter the combined analog signal to generate a first filtered signal. The first filtered signal may be converted by a first converter to generate a range rate signal. The second filter may filter the combined analog signal to generate a second filtered signal. The second filtered signal may be converted by a second converter to generate a range signal.

#### BRIEF DESCRIPTION OF THE DRAWINGS

**[0034]** FIG. 1 illustrates a system for monitoring an individual according to one or more embodiments of the invention.

**[0035]** FIG. 2 illustrates a laser radar system that may be implemented in the system for monitoring an individual according to one or more embodiments of the invention.

**[0036]** FIG. 3 illustrates a laser radar system that may be implemented in the system for monitoring an individual according to one or more embodiments of the invention.

**[0037]** FIG. 4 illustrates a processor that digitally mixes two combined target beams according to one or more embodiments of the invention.

**[0038]** FIG. 5 illustrates a processor that electrically mixes two combined target beams according to one or more embodiments of the invention.

**[0039]** FIG. 6 illustrates a processor that optically mixes two combined target beams according to one or more embodiments of the invention.

#### DETAILED DESCRIPTION

**[0040]** FIG. 1 is an exemplary illustration of a system 110 for remotely monitoring an individual 112, in accordance with some embodiments of the invention. System 110 may monitor one or more physiological functions and/or physical activities of individual 112. System 110 may include a laser radar system 116 capable of determining a range to and/or a range rate (i.e., velocity) of a point on a surface of individual 112 (e.g., skin, clothing, lips, etc.). System 110 may include

a monitor module **118** capable of monitoring one or more physiological functions and/or physical activities of individual **112** based on the determinations of laser radar system **116**. System **110** may enable the physiological functions and/or physical activities to be monitored remotely from individual **112** without directly contacting individual **112**. In other words, monitoring the physiological functions and/or physical activities of individual **112** via system **110** may be accomplished in a manner that may be indiscernible to individual **112**.

[0041] In some embodiments of the invention, laser radar system **116** may direct a beam of electromagnetic radiation **114** toward individual **112** to be incident on individual **112** at the point on the surface of individual **112** to be measured. Some or all of radiation **114** directed to the point on the surface of individual **112** may be reflected by the surface, and may then be received back into laser radar system **116**. As described below, based on one or more aspects of radiation **114** (e.g., frequency, phase, intensity, etc.) prior to emission and/or subsequent to reflection, laser radar system **116** may determine one or both of the range and the range rate of the point on the surface with respect to laser radar system **116**.

[0042] According to various embodiments of the invention, laser radar system **116** may make a plurality of determinations of range and/or range rate of a point on a surface of individual **112** (e.g., at a periodic rate) over a period of time. Monitor module **118** may implement the determined ranges and range rates to determine general trends in the ranges and/or range rates over the period of time, and residual deviations from the determined general trends. Monitor module **118** may implement the determined general trends in the ranges and/or range rates to estimate body (or body member) motion, while the residual deviations from the determined trends may be used to estimate surface vibrations of the surface of individual **112**. The observed surface vibrations may include one or both of short period vibrations and long period vibrations. Based on the estimated body motion and/or surface vibrations, one or more physiological functions and/or physical activities of individual **112** may be monitored by monitor module **118**.

[0043] In some embodiments, ranges and/or range rates of a plurality of points on one or more surfaces of individual **112** may be determined by laser radar system **116**. For example, laser radar system **116** may scan radiation **114** at emission such that the point at which radiation **114** is directed on individual **112** may be scanned across individual **112** in a raster. In such embodiments, laser radar system **116** may monitor one or more surface areas on individual **112** (e.g., a chest area, a neck area, a wrist area, a facial area, etc.), or laser radar system **116** may monitor the entire surface of individual **112** exposed on a line of sight to laser radar system **116**.

[0044] According to various embodiments of the invention, the physiological functions and/or physical activities of individual **112** monitored by monitor module **118** based on the estimations of body motion and/or surface vibrations of individual **112** may include one or more cardiovascular functions, one or more respiratory function, other physiological functions, and other physical activities. Cardiovascular functions may include a heart rate, a heart rate variability, a pulse transit time, a pulse shape, and/or other cardiovascular functions. Respiratory functions may include a respiration rate, a respiratory effort, and/or other respiratory functions. Physical activities may include speaking, coughing, sneezing, walking, running, or other physical activities. In some instances,

the physiological functions and/or physical activities may include one or more physiological functions which may be inferred from others of the physiological functions and/or physical activities. Examples of this may include, a vascular tone that may be inferred from a pulse transit time, and/or an autonomic tone that may be inferred from a pulse shape.

[0045] FIG. 2 illustrates a frequency modulated laser radar system **210** that may be implemented within system **110** as laser radar system **116**, according to some embodiments of the invention. System **210** may include a laser source **212** that emits a beam **214** of electromagnetic radiation. Beam **214** may be emitted at a frequency that is continuously varied, or chirped. In some instances, chirping the frequency may include sweeping the frequency between a lower frequency and an upper frequency (or vice versa) in a periodic manner (e.g. a sawtooth waveform, a triangle waveform, etc.). Beam **214** may be divided by an optical coupler **216** into a target beam **218** and a reference beam **220**.

[0046] In conventional embodiments, system **210** may include a target interferometer **222** and a reference interferometer **224**. Target interferometer **222** may receive target beam **218**, and may divide the target beam at an optical coupler **226**. Target interferometer **222** is typically used to generate a target signal that may depend upon a range of a target **230** (e.g. individual **112**) from target interferometer **222**. Target interferometer may accomplish this by directing one portion **228** of target beam **218** toward target **230**, and the other portion **232** of target beam **218** to a target frequency difference module **234** over an optical path with a fixed path length. Portion **228** of target beam **218** may be reflected by target **230** and may be transmitted to target frequency difference module **234** via optical coupler **226** and an optical fiber **236**. Based on interference between portions **236** and **232** at coupler **248**, target frequency difference module **234** may generate the target signal corresponding to a beat frequency of portions **236** and **232** of target beam **218** due to the difference between their path lengths.

[0047] According to various embodiments of the invention, reference interferometer **224** may receive reference beam **220** and may generate a reference signal corresponding to a frequency difference between two portions of reference beam **224** that may be directed over two separate fixed paths with a known path length difference. More particularly, reference beam **220** may be divided by an optical coupler **240** into a first portion **242** and a second portion **244**. First portion **242** may have a fixed optical path length difference relative to second portion **244**. Based on interference between portions **242** and **244** at coupler **246**, reference frequency difference module **250** may generate the reference signal corresponding to a beat frequency of portions **242** and **244** of reference beam **220** caused by the fixed difference between their path lengths.

[0048] As will be appreciated, target interferometer **222** and reference interferometer **224** have been illustrated and described as Mach-Zehnder interferometers. However other interferometer configurations may be utilized. For example, target interferometer **222** and reference interferometer **224** may include embodiments wherein Michelson-Morley interferometers may be formed.

[0049] In some embodiments, system **210** may include a processor **238**. Processor **238** may receive the target signal and the reference signal and may process these signals to determine the range of target **230**. Range information deter-

mined based on the target signal and the reference signal may be used to determine a range rate of target 230 with respect to target interferometer 222.

[0050] FIG. 3 illustrates an exemplary embodiment of a laser radar system 310 that may be implemented within system 110, as laser radar system 116, to monitor one or more points on a surface of individual 112, according to some embodiments of the invention. Laser radar system 310 may employ two or more laser radar sections, each of which emits a target beam of radiation toward a target. For example, a first laser radar section 374 emits a first target beam 312 and a second laser radar section 376 emits a second target beam 314 toward a target 316 (e.g., individual 112). In some embodiments of the invention, first target beam 312 and second target beam 314 may be chirped to create a dual chirp system. The implementation of laser radar system 310 in system 110 to monitor one or more points on a surface of individual 112 may provide unambiguous determinations of the range and the range rate of the points on the surface of individual 112 with respect to system 110, and may enable enhanced monitoring of one or more physiological functions and/or physical activities of individual 112 by monitoring module 118. For example, the unambiguous determination of the range and/or the range rate of the points on the surface of individual 112 may reduce an amount of noise in the determined ranges and/or range rates. If present, the noise may impact the accuracy of the determinations of the ranges and/or range rates. Inaccuracies within the determined ranges and/or range rates may hamper determinations that leverage the determined ranges and/or range rates to monitor physiological functions and/or physical activities of individual 112, such as determinations of general trends in the ranges and/or range rates that indicate body motion, and/or residual deviation(s) from the general trends indicative of surface vibrations.

[0051] According to various embodiments of the invention, laser section 374 may include a laser source controller 336, a first laser source 318, a first optical coupler 322, a first beam delay 344, a first local oscillator optical coupler 330, and/or other components. Second laser radar section 376 may include a laser source controller 338, a second laser source 320, a second optical coupler 324, a second beam delay 350, a second local oscillator optical coupler 332 and/or other components. For example, some or all of the components of each of laser radar sections 374 and 376 may be obtained as a coherent laser radar system from Metris USA. Coherent laser radar systems from Metris USA may provide various advantages, such as enhanced linearity functionality, enhanced phase wandering correction, and other advantages to laser radar system 310 in determining the range and the range rate of target 316.

[0052] In some embodiments of the invention, first target beam 312 and second target beam 314 may be reflected by target 316 back toward laser radar system 310. Laser radar system 310 may receive first target beam 312 and second target beam 314, and may determine at least one of a range of target 316 from laser radar system 310, and a range rate of target 316.

[0053] According to various embodiments of the invention, first laser source 318 may have a first carrier frequency. First laser source 318 may emit a first laser beam 340 at a first frequency. The first frequency may be modulated at a first chirp rate. The first frequency may be modulated electrically, mechanically, acousto-optically, or otherwise modulated as would be apparent. First laser beam 340 may be divided by

first optical coupler 322 into first target beam 312 and a first local oscillator beam 342. First local oscillator beam 342 may be held for a first delay period at a first beam delay 344.

[0054] In some embodiments of the invention, second laser source 320 may emit a second laser beam 346 at a second frequency. The second frequency may be modulated at a second chirp rate different from the first chirp rate. The second frequency may be modulated electrically, mechanically, acousto-optically, or otherwise modulated. The first chirp rate and the second chirp rate may create a counter chirp between first laser beam 340 and second laser beam 346.

[0055] In some instances, the second carrier frequency may be substantially the same as the first carrier frequency. For example, in some embodiments the percentage difference between the first baseline frequency and the second baseline frequency is less than 0.05%. This may provide various enhancements to laser system 310, such as, for example, minimizing distortion due to speckle, or other enhancements. Second laser beam 346 may be divided by second optical coupler 324 into a second target beam 314 and a second local oscillator beam 348. Second local oscillator beam 348 may be held for a second delay period at a second beam delay 350. The second delay period may be different than the first delay period.

[0056] In some embodiments, the output(s) of first laser source 318 and/or second laser source 320 (e.g. first laser beam 340 and/or second laser beam 346) may be linearized using mechanisms provided in, for example, Metris USA Model MV200. Phase wandering of the output(s) of first laser source 318 and/or second laser source 320 may be corrected using mechanisms provided in, for instance, Metris USA Model MV200.

[0057] In some embodiments of the invention, laser radar system 310 may determine the range and the range rate of target 316 with an increased accuracy when the range of target 316 from laser radar system 310 falls within a set of ranges between a minimum range and a maximum range. When the range of target 316 does not fall within the set of ranges, the accuracy of laser radar system 310 may be degraded.

[0058] According to various embodiments of the invention, first beam delay 344 and second beam delay 350 may be adjustable. Adjusting first beam delay 344 and second beam delay 350 may enable laser radar system 310 to be adjusted to bring the set of ranges over which more accurate determinations may be made closer to, or further away from, laser radar system 310. First beam delay 344 and the second beam delay 350 may be adjusted to ensure that the range of target 316 falls within the set of ranges between the minimum range and the maximum range so that the range and the range rate of target 316 may be determined accurately. First beam delay 344 and second beam delay 350 may be adjusted by a user, or in an automated manner.

[0059] The degradation of determinations of range and range rate when the range of target 316 is outside of the set of ranges may be a result of the finite nature of the coherence length of first laser source 318 and second laser source 320. For example, the distance between the minimum range and the maximum range may be a function of the coherence length. The longer the coherence length of first laser source 318 and second laser source 320, the greater the distance between the minimum range and the maximum range may be. Thus, increasing the coherence length of first laser source 318 and second laser source 320 may enhance range and range

rate determinations by laser radar system 310 by providing the ability to make determinations over an enhanced set of ranges.

[0060] In some embodiments of the invention, first local oscillator beam 342 may be divided into a plurality of first local oscillator beams and second local oscillator beam 348 may be divided into a plurality of second local oscillator beams. In such instances, laser radar system 310 may include a plurality of beam delays that may apply delays of varying delay periods to the plurality of first local oscillator beams and the plurality of second local oscillator beams. This may ensure that one of the plurality of first local oscillator beams and one of the plurality of second local oscillator beams may have been delayed for delay periods that may enable the range and range rate of the target to be determined accurately.

[0061] Accordingly, in some embodiments of the invention, first laser source 318 and second laser source 320 may emit chirped electromagnetic radiation with an enhanced coherence length. For example, first laser source 318 and/or second laser source 320 may include system 310 as illustrated in FIG. 3 and described above.

[0062] According to various embodiments, first target beam 312 and second target beam 314 may be directed and/or received from target 316 on separate optical paths. In some embodiments, these optical paths may be similar but distinct. In other embodiments, first target beam 312 and second target beam 314 may be coupled by a target optical coupler 326 into a combined target beam 352 prior to emission that may be directed toward target 316 along a common optical path. In some embodiments, combined target beam 352 (or first target beam 312 and second target beam 314, if directed toward target 316 separately) may be reflected by target 316 and may be received by laser radar system 310 along a reception optical path separate from the common optical path that directed combined target beam 352 toward target 316. Such embodiments may be labeled "bistatic." Or, combined target beam 352 may be received by laser radar system 310 as a reflected target beam 356 along the common optical path. These latter embodiments may be labeled "monostatic." Monostatic embodiments may provide advantages over their bistatic counterparts when operating with reciprocal optics. In monostatic embodiments, the common optical path may include optical member 328 that may provide a common port for emitting combined target beam 352 and receiving reflected target beam 356. Optical member 328 may include an optical circulator, an optical coupler or other optical member as would be apparent.

[0063] In some embodiments, the common optical path may include a scanning element 337. Scanning element 337 may include an optical element such as, for instance, a mirror, a lens, an antenna, or other optical elements that may be oscillated, rotated, or otherwise actuated to enable combined target beam 352 to scan target 316. In some instances, scanning element 337 may enable scanning at high speeds. In conventional systems, scanning elements may be a source of mirror differential Doppler noise effects due to speckle or other optical effects that may degrade the accuracy of these systems. However, because various embodiments of laser radar system 310 use simultaneous measurements (or substantially so) to unambiguously determine range and range rate, inaccuracies otherwise induced by high speed scanning may be avoided.

[0064] In some embodiments of the invention, a target optical coupler 354 may divide reflected target beam 356 into a

first reflected target beam portion 358 and a second reflected target beam portion 360. First local oscillator optical coupler 330 may combine first local oscillator beam 342 with first reflected target beam portion 358 into a first combined target beam 362. Second local oscillator optical coupler 332 may combine second local oscillator beam 348 with second reflected target beam portion 360 into a second combined target beam 364. In some embodiments not shown in the drawings, where, for example first target beam 312 and second target beam 314 may be directed to and/or received from target 316 separately, first local oscillator optical coupler 330 may combine first target beam 312 that is reflected with first local oscillator beam 342 to create first combined target beam 362, and second target beam 314 that is reflected may be combined with second local oscillator beam 348 to create second combined target beam 364.

[0065] Because first local oscillator beam 342 and second local oscillator beam 348 may be combined with different target beams, or different portions of the same target beam (e.g. reflected target beam 356), first combined target beam 362 and second combined target beam 364 may represent optical signals that might be present in two separate, but coincident, single laser source frequency modulated laser radar systems, just prior to final processing. For example, laser source controller 336, first laser source 318, first optical coupler 322, first beam delay 344, and first local oscillator optical coupler 330 may be viewed as a first laser radar section 374 that may generate first combined target beam 362 separate from second combined target beam 364 that may be generated by a second laser radar section 376. Second laser radar section 376 may include laser source controller 338, second laser source 320, second optical coupler 324, second beam delay 350, and second local oscillator optical coupler 332.

[0066] In some embodiments, laser radar system 310 may include a processor 334. Processor 334 may include a detection module 366, a mixing module 368, a processing module 370, and/or other modules. The modules may be implemented in hardware (including optical and detection components), software, firmware, or a combination of hardware, software, and/or firmware. Processor 334 may receive first combined target beam 362 and second combined target beam 364. Based on first combined target beam 362 and second combined target beam 364, processor 334 may generate the range signal and the range rate signal. Based on the range signal and the range rate signal, the range and the range rate of target 316 may be unambiguously determined.

[0067] In some embodiments of the invention, processor 334 may determine a first beat frequency of first combined local oscillator beam 362. The first beat frequency may include a difference in frequency, attributable to a difference in path length, of first local oscillator beam 342 and the component of reflected target beam 356 that corresponds to first target beam 312 that has been reflected from target 316. Processor 334 may determine a second beat frequency of second combined local oscillator beam 364. The second beat frequency may include a difference in frequency, attributable to a difference in path length, of second local oscillator beam 348 and the component of reflected target beam 356 that corresponds to second target beam 314 that has been reflected from target 316. The first beat frequency and the second beat frequency may be determined simultaneously (or substantially so) to cancel noise introduced by environmental or other effects. One or more steps may be taken to enable the first beat

frequency and the second beat frequency to be distinguished from other frequency components within first combined target beam 362, other frequency components within second combined target beam 364, and/or each other. For example, these measures may include using two separate chirp rates as the first chirp rate and the second chirp rate, delaying first local oscillator beam 342 and second local oscillator beam 350 for different delay times at first beam delay 344 and second beam delay 350, respectively, or other measures may be taken.

[0068] It will be appreciated that while FIG. 3 illustrates an exemplary embodiment of the invention implemented primarily using optical fibers and optical couplers, this embodiment is in no way intended to be limiting. Alternate embodiments within the scope of the invention exist in which other optical elements such as, for example, prisms, mirrors, half-mirrors, beam splitters, dichroic films, dichroic prisms, lenses, or other optical elements may be used to direct, combine, direct, focus, diffuse, or otherwise process electromagnetic radiation.

[0069] According to various embodiments of the invention, processor 334 may mix first combined target beam 362 and second combined target beam 364 to produce a mixed signal. The mixed signal may include a beat frequency sum component that may correspond to the sum of the first beat frequency and the second beat frequency, and a beat frequency difference component that may correspond to the difference between the first beat frequency and the second beat frequency. For a target having constant velocity, first laser beam 340 and second laser beam 346 beat frequencies may be described as follows:

$$f_1(t) = \frac{4\pi v}{\lambda_1} + 2\pi\gamma_1(R - RO_1), \text{ and} \quad (1)$$

$$f_2(t) = \frac{4\pi v}{\lambda_2} + 2\pi\gamma_2(R - RO_2), \text{ respectively,} \quad (2)$$

where  $f_1(t)$  represents the first beat frequency,  $f_2(t)$  represents the second beat frequency,  $\lambda_1$  and  $\lambda_2$  are the two optical wavelengths,  $v$  is the target velocity,  $\gamma_1$  and  $\gamma_2$  are proportional to the respective chirp rates,  $R$  is the measured range and  $RO_1$  and  $RO_2$  represent the range offsets for the two laser radars. Now assume that  $\lambda_1 = \lambda_2 = \lambda$ . We may subtract the equations to yield

$$f_1(t) - f_2(t) = 2\pi R(\gamma_1 - \gamma_2) - 2\pi(\gamma_1 RO_1 - \gamma_2 RO_2) \quad (3)$$

Rearranging (3) we obtain

$$R = \frac{(f_1(t) - f_2(t))}{2\pi(\gamma_1 - \gamma_2)} + \frac{(\gamma_1 RO_1 - \gamma_2 RO_2)}{(\gamma_1 - \gamma_2)} \quad (4)$$

as the corrected range measurement. Similarly we may combine (1) and (2) to obtain the expression,

$$v = \frac{\lambda}{4\pi} \left( \frac{f_1(t) - \frac{\gamma_1}{\gamma_2} f_2(t)}{1 - \frac{\gamma_1}{\gamma_2}} \right) + \frac{\lambda \gamma_1}{2} \left( \frac{RO_1 - RO_2}{1 - \frac{\gamma_1}{\gamma_2}} \right), \quad (5)$$

which provides a measure of the target velocity.

[0070] According to various embodiments of the invention, the beat frequency sum component, described above in Equation 4, may be filtered from the mixed signal to produce a range signal. From the beat frequency sum component included in the range signal (e.g.  $f_1(t) + f_2(t)$ ), a determination of the distance from laser radar system 310 to target 316 may be made. The determination based on the range signal may be unambiguous, and may not depend on either the instantaneous behavior, or the average behavior of the Doppler frequency shift (e.g.  $v/\lambda$ ).

[0071] In some embodiments, the beat frequency difference component, described above in Equation 4, may be filtered from the mixed signal to produce a range rate signal. From the beat frequency difference component included in the range rate signal, a determination of the range rate of target 316 may be unambiguously made. To determine the range rate of target 316,

$$f_1(t) - \frac{\gamma_1}{\gamma_2} f_2(t)$$

may be represented as a value proportional to a chirp rate difference between the first chirp rate and the second chirp rate. This may enable the Doppler shift information to be extracted, which may represent an instantaneous velocity (i.e., range rate) of target 316.

[0072] In some embodiments of the invention, the second chirp rate may be set to zero. In other words, second laser source 318 may emit radiation at a constant frequency. This may enable second laser source 318 to be implemented with a simpler design, a small footprint, a lighter weight, a decreased cost, or other enhancements that may provide advantages to the overall system. In such embodiments, laser radar system 310 may include a frequency shifting device. The frequency shifting device may include an acousto-optical modulator 372, or other device. Acousto-optical modulator 372 may provide a frequency offset to second local oscillator beam 348, which may enhance downstream processing. For example, the frequency offset may enable a stationary target beat frequency between second local oscillator beam 348 and second reflected target beam portion 360 representative of a range rate of a stationary target to be offset from zero so that the a direction of the target's movement, as well as a magnitude of the rate of the movement, may be determined from the beat frequency. This embodiment of the invention has the further advantage that it may allow for continuous monitoring of the target range rate, uninterrupted by chirp turn-around or fly-back. Chirp turn-around or fly-back may create time intervals during which accurate measurements may be impossible for a chirped laser radar section. In these embodiments, laser radar section 376 may only determine the range rate of target 316 while laser radar system 310 retains the ability to measure both range and range rate.

[0073] FIG. 4 illustrates a processor 334 according to one embodiment of the invention. Processor 334 may mix first combined target beam 362 and second combined target beam 364 digitally. For example, processor 334 may include a first detector 410 and a second detector 412. The first detector 410 may receive first combined target beam 362 and may generate a first analog signal that corresponds to first combined target beam 362. The first analog signal may be converted to a first digital signal by a first converter 414. Processor 334 may include a first frequency data module 416 that may determine

a first set of frequency data that corresponds to one or more frequency components of the first digital signal. In some instances, the first digital signal may be averaged at a first averager module **418**. In such instances, the averaged first digital signal may then be transmitted to first frequency data module **416**.

[0074] Second detector **412** may receive second combined target beam **364** and may generate a second analog signal that corresponds to second combined target beam **364**. The second analog signal may be converted to a second digital signal by a second converter **420**. Processor **334** may include a second frequency data module **422** that may determine a second set of frequency data that corresponds to one or more of frequency components of the second digital signal. In some instances, the second digital signal may be averaged at a second averager module **424**. In such instances, the averaged second digital signal may then be transmitted to second frequency data module **422**.

[0075] The first set of frequency data and the second set of frequency data may be received by a frequency data combination module **426**. Frequency data combination module **426** may linearly combine the first set of frequency data and the second set of frequency data, and may generate a range rate signal and a range signal derived from the mixed frequency data.

[0076] FIG. 5 illustrates a processor **334** according to another embodiment of the invention. Processor **334** may include a first detector **510** and a second detector **512** that may receive first combined target beam **362** and second combined target beam **364**, respectively. First detector **510** and second detector **512** may generate a first analog signal and a second analog signal associated with first combined target beam **362** and second combined target beam **364**, respectively. Processor **334** may mix first combined target beam **362** and second combined target beam **364** electronically to generate the range signal and the range rate signal. For example, processor **334** may include a modulator **514**. Modulator **514** may multiply the first analog signal generated by first detector **510** and the second analog signal generated by second detector **512** to create a combined analog signal. In such embodiments, processor **334** may include a first filter **516** and a second filter **518** that receive the combined analog signal. First filter **516** may filter the combined analog signal to generate a first filtered signal. In some instances, first filter **516** may include a low-pass filter. The first filtered signal may be converted by a first converter **520** to generate the range rate signal. Second filter **518** may filter the combined analog signal to generate a second filtered signal. For instance, second filter **518** may include a high-pass filter. The second filtered signal may be converted by a second converter **522** to generate the range signal.

[0077] FIG. 6 illustrates a processor **334** according to yet another embodiment of the invention. Processor **334** may mix first combined target beam **362** and second combined target beam **364** optically to generate the range signal and the range rate signal. For example, processor **334** may include a detector **610** that receives first combined target beam **362** and second combined target beam **364** and generates a combined analog signal based on the detection. In such embodiments, processor **334** may include a first filter **612** and a second filter **614** that receive the combined analog signal. First filter **612** may filter the combined analog signal to generate a first filtered signal. First filter **612** may include a low-pass filter. The first filtered signal may be converted by a first converter

**616** to generate the range rate signal. Second filter **614** may filter the combined analog signal to generate a second filtered signal. Second filter **614** may include a high-pass filter. The second filtered signal may be converted by a second converter **618** to generate the range signal.

[0078] While the invention has been described herein in terms of various embodiments, it is not so limited and is limited only by the scope of the following claims, as would be apparent to one skilled in the art.

What is claimed is:

1. A system for remotely monitoring an individual, the system comprising:

a laser radar system that determines ranges and range rates of one or more points on one or more surfaces of the individual over a period of time; and

a monitor module that monitors one or more physiological functions or physical activities of the individual based on the ranges and range rates determined by the laser radar system.

2. The system of claim 1, wherein the monitor module determines one or more general trends in the ranges and range rates and one or more residual deviations in the ranges and range rates, and monitors the one or more physiological functions or physical activities of the individual based on the general trends in the ranges and range rates and/or the residual deviations in the ranges and range rates.

3. The system of claim 2, wherein the monitor module estimates body motion of the individual from the general trends in the ranges and range rates, estimates surface vibrations of the surfaces of the individual from the residual deviations from the general trends in the ranges and range rates, and monitors the one or more physiological functions or physical activities of the individual based on the estimated body motion and/or the estimated surface vibrations.

4. The system of claim 1, wherein the one or more physiological functions or physical activities comprise at least one of a cardiovascular function or a respiratory function.

5. The system of claim 4, wherein the one or more physiological functions or physical activities comprise at least one of a heart rate, a heart rate variability, a pulse transit time, a pulse shape, a respiration rate, or a respiratory effort.

6. The system of claim 1, wherein the one or more physiological functions or physical activities comprise at least one of speaking, coughing, sneezing, walking, or running.

7. A method of remotely monitoring an individual, the method comprising:

emitting a beam of radiation sequentially toward one or more points on one or more surfaces of the individual;

receiving a portion of the beam of radiation reflected from the points on the surfaces of the individual;

determining ranges and range rates of the points on the surfaces of the individual based on one or more aspects of the beam of radiation; and

monitoring one or more physiological functions or physical activities of the individual based on the ranges and range rates of the points on the surfaces of the individual.

8. The method of claim 7, further comprising determining one or more general trends in the ranges and range rates and one or more residual deviations in the ranges and range rates, and wherein monitoring the one or more physiological functions or physical activities of the individual comprises monitoring the one or more physiological functions or physi-

cal activities of the individual based on the general trends in the ranges and range rates and/or the residual deviations in the ranges and range rates.

9. The method of claim 8, further comprising:

estimating body motion of the individual from the general trends in the ranges and range rates; and

estimating surface vibrations of the surfaces of the individual from the residual deviations from the general trends in the ranges and range rates,

and wherein monitoring the one or more physiological functions or physical activities of the individual comprises monitoring the one or more physiological functions or physical activities of the individual based on the estimated body motion and/or the estimated surface vibrations.

10. The method of claim 7, wherein the one or more physiological functions or physical activities comprise at least one of a cardiovascular function or a respiratory function.

11. The method of claim 10, wherein the one or more physiological functions or physical activities comprise at least one of a heart rate, a heart rate variability, a pulse transit time, a pulse shape, a respiration rate, or a respiratory effort.

12. The method of claim 7, wherein the one or more physiological functions or physical activities comprise at least one of speaking, coughing, sneezing, walking, or running.

13. A system for monitoring an individual, the system comprising:

a first coherent laser radar section including:

a laser source that generates a first laser beam,

an interferometer that splits the first laser beam into a first target beam that is directed toward the individual and a first local oscillator beam, and generates a first combined target beam from a first reflected portion of the first target beam returning from the individual and the first local oscillator beam;

a second coherent laser radar section including:

a laser source that generates a second laser beam,

an interferometer that splits the second laser beam into a second target beam that is directed toward the individual with the first target beam and a second local

oscillator beam, and generates a second combined target beam from a second reflected portion of the second target beam returning from the individual and the second local oscillator beam;

a processor that determines ranges and range rates of one or more points on one or more surfaces of the individual over a period of time from the first combined target beam and the second combined target beam, and

wherein the processor monitors one or more physiological functions or physical activities of the individual based on the ranges and range rates determined by the processor.

14. The system of claim 13, wherein the processor determines one or more general trends in the ranges and range rates and one or more residual deviations in the ranges and range rates, and monitors the one or more physiological functions or physical activities of the individual based on the general trends in the ranges and range rates and/or the residual deviations in the ranges and range rates.

15. The system of claim 14, wherein the processor estimates body motion of the individual from the general trends in the ranges and range rates, estimates surface vibrations of the surfaces of the individual from the residual deviations from the general trends in the ranges and range rates, and monitors the one or more physiological functions or physical activities of the individual based on the estimated body motion and/or the estimated surface vibrations.

16. The system of claim 13, wherein the one or more physiological functions or physical activities comprise at least one of a cardiovascular function or a respiratory function.

17. The system of claim 16, wherein the one or more physiological functions or physical activities comprise at least one of a heart rate, a heart rate variability, a pulse transit time, a pulse shape, a respiration rate, or a respiratory effort.

18. The system of claim 13, wherein the one or more physiological functions or physical activities comprise at least one of speaking, coughing, sneezing, walking, or running.

\* \* \* \* \*

专利名称(译)	用于远程监测生理功能的系统和方法		
公开(公告)号	<a href="#">US20090216093A1</a>	公开(公告)日	2009-08-27
申请号	US12/393537	申请日	2009-02-26
[标]申请(专利权)人(译)	数字信号公司		
申请(专利权)人(译)	数字信号CORPORATION		
当前申请(专利权)人(译)	数字信号CORPORATION		
[标]发明人	SEBASTIAN RICHARD L BELSLEY KENDALL L		
发明人	SEBASTIAN, RICHARD L. BELSLEY, KENDALL L.		
IPC分类号	A61B5/00 A61B6/00		
CPC分类号	A61B5/021 A61B5/113 A61B5/1114 A61B5/1113 A61B5/0059 A61B5/0062 A61B5/11		
优先权	60/611295 2004-09-21 US 60/651989 2005-02-14 US		
其他公开文献	US9872639		
外部链接	<a href="#">Espacenet</a> <a href="#">USPTO</a>		

摘要(译)

根据本发明的一些实施例的用于远程监控个人的系统和方法。更具体地，可以监测个体的一种或多种生理功能和/或身体活动。为了监测个体，个体的一个或多个表面（例如，皮肤，衣服，嘴唇等）上的一个或多个点的范围和/或范围速率（即，速度）可以是确定一段时间。基于个体表面上的点的范围和/或范围速率的确定，可以监测个体的一个或多个生理功能和/或身体活动。这可以使得能够远离个体远程监测生理功能和/或身体活动，而无需访问或接近个体。

