



US 20080221410A1

(19) **United States**

(12) **Patent Application Publication**
Campbell et al.

(10) **Pub. No.: US 2008/0221410 A1**

(43) **Pub. Date: Sep. 11, 2008**

(54) **METHOD FOR IDENTIFICATION OF
SENSOR SITE BY LOCAL SKIN SPECTRUM
DATA**

(22) Filed: **Mar. 9, 2007**

Publication Classification

(75) Inventors: **Shannon E. Campbell**, Oakland,
CA (US); **Martin P. Debreczeny**,
Danville, CA (US); **Carine
Hoarau**, Lafayette, CA (US)

(51) **Int. Cl.**
A61B 5/00 (2006.01)

(52) **U.S. Cl.** **600/310; 600/323**

(57) **ABSTRACT**

Correspondence Address:
NELLCOR PURITAN BENNETT LLC
ATTN: IP LEGAL
60 Middletown Avenue
North Haven, CT 06473 (US)

A method is provided for determining the location of the sensor. The method comprises determining a physiological parameter based on detected light and determining the location of the sensor based on the physiological parameter. In addition, a method is provided for operating a sensor that includes calibrating a sensor based on a patient-specific physiological parameter, in which the patient-specific physiological parameter is skin color, age, gender, pooled blood, venous blood pulsation, or abnormal tissue.

(73) Assignee: **Nellcor Puritan Bennett LLC**

(21) Appl. No.: **11/716,264**

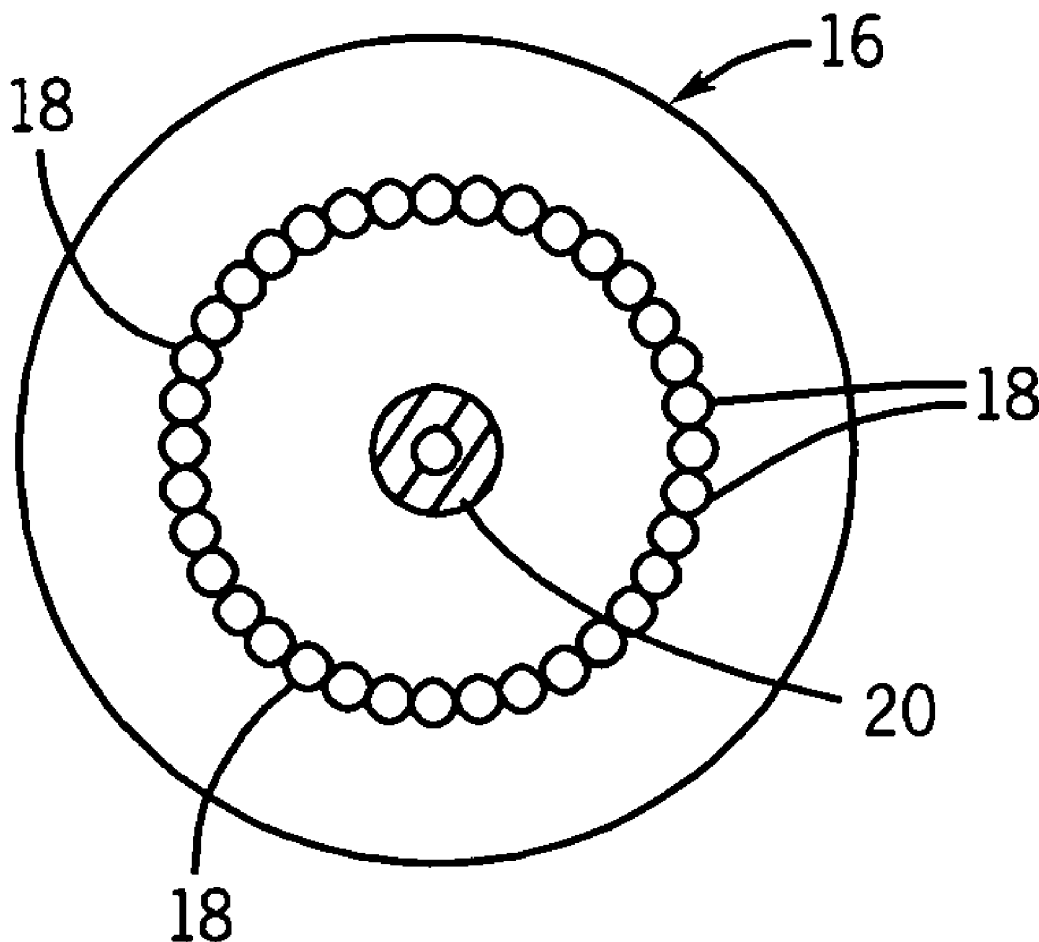

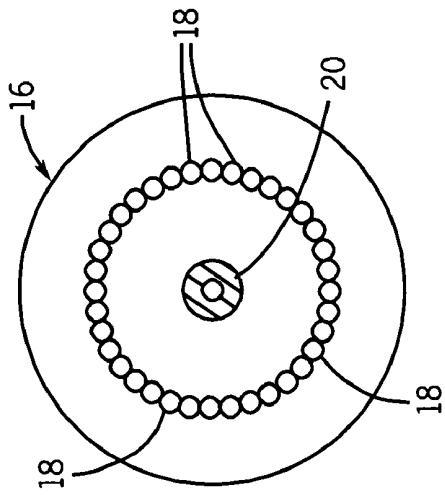

FIG. 2

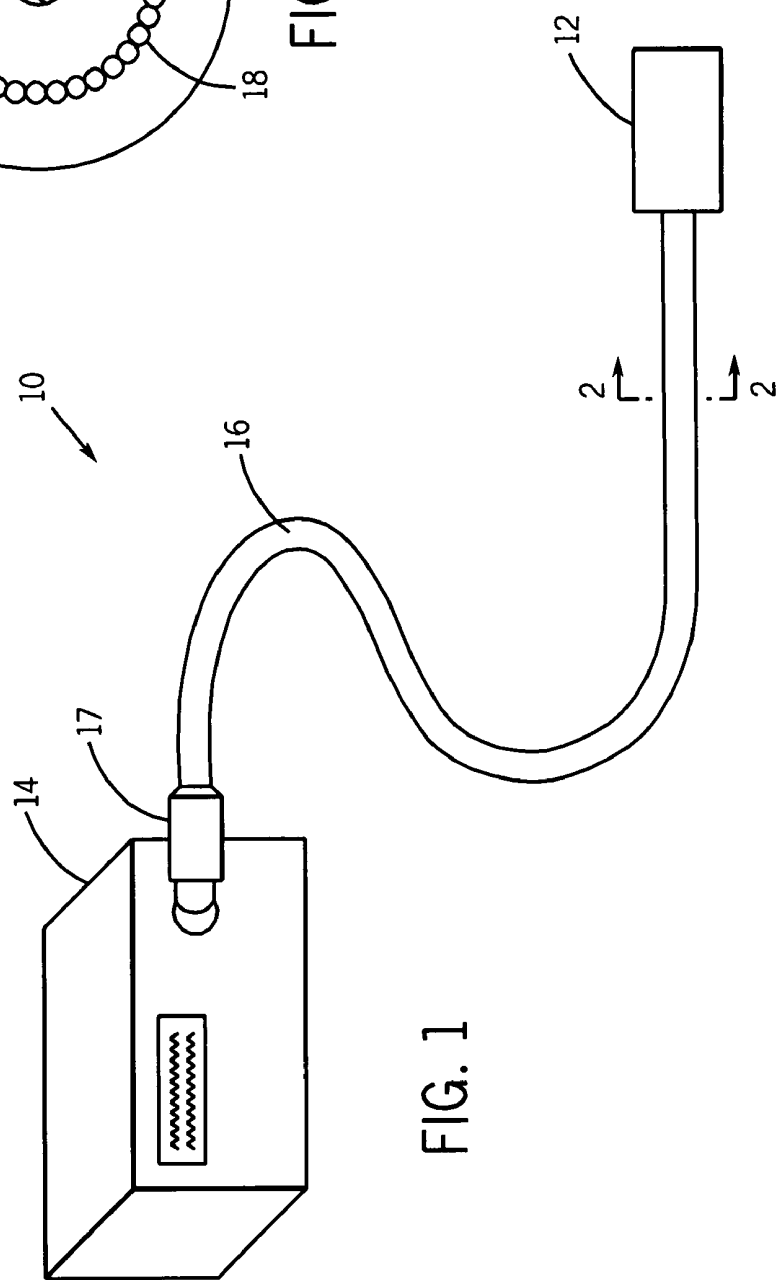

FIG. 1

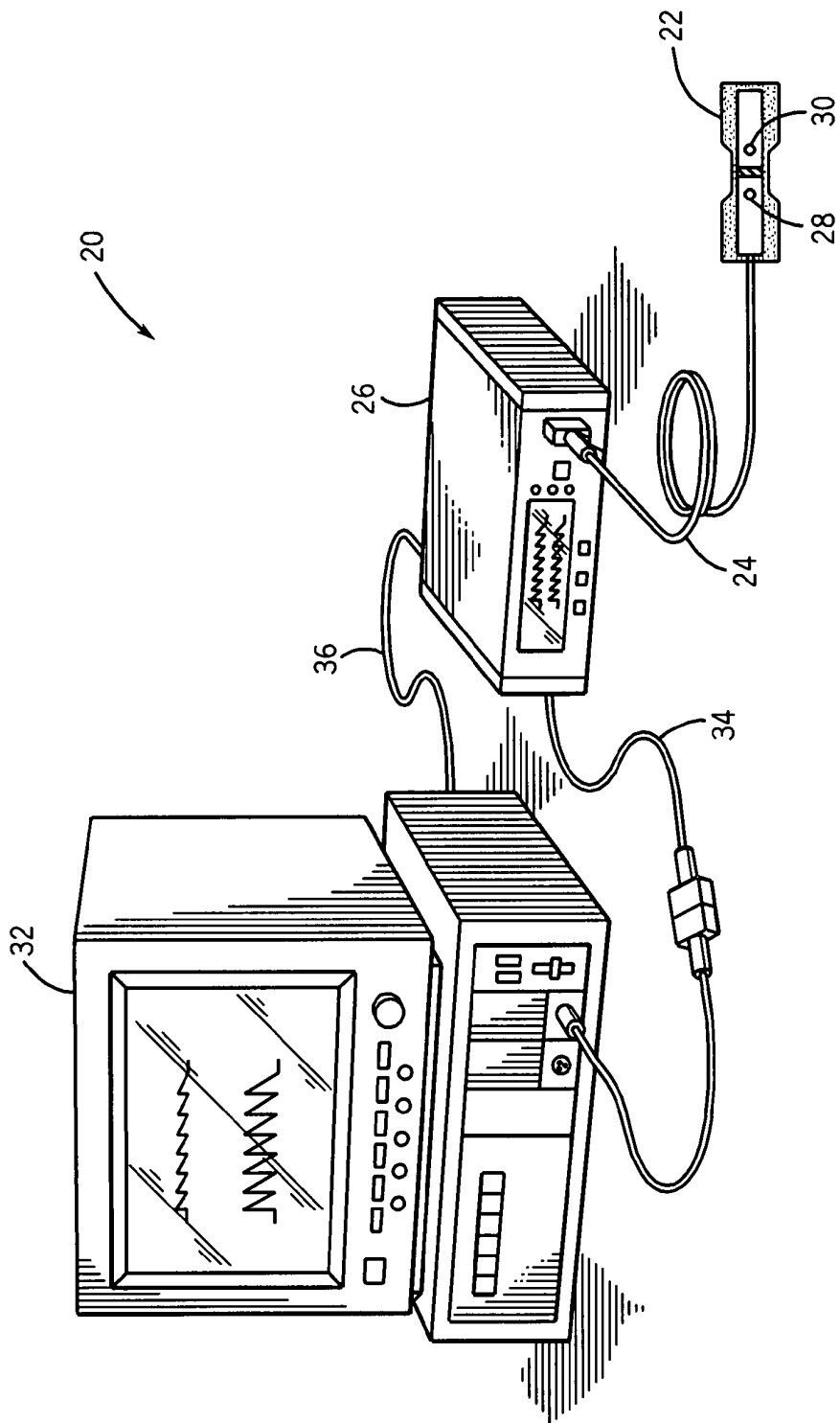
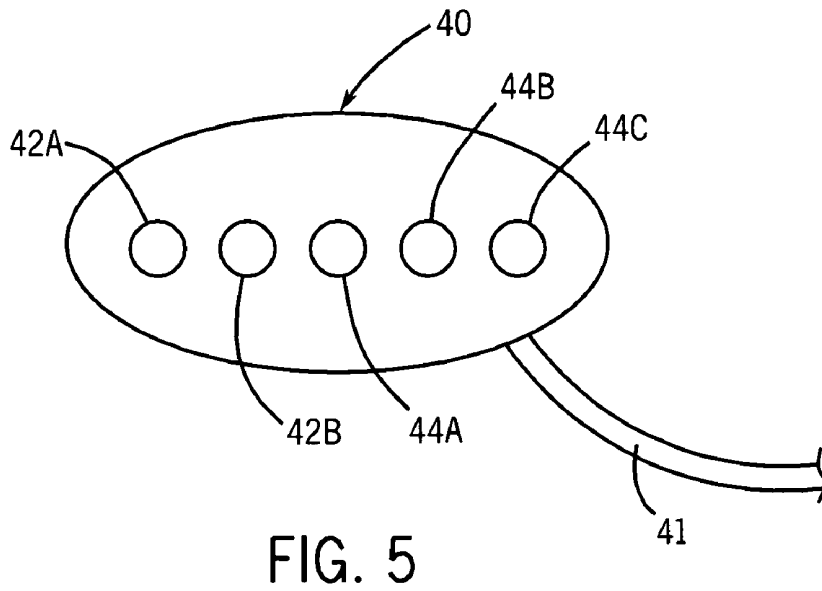
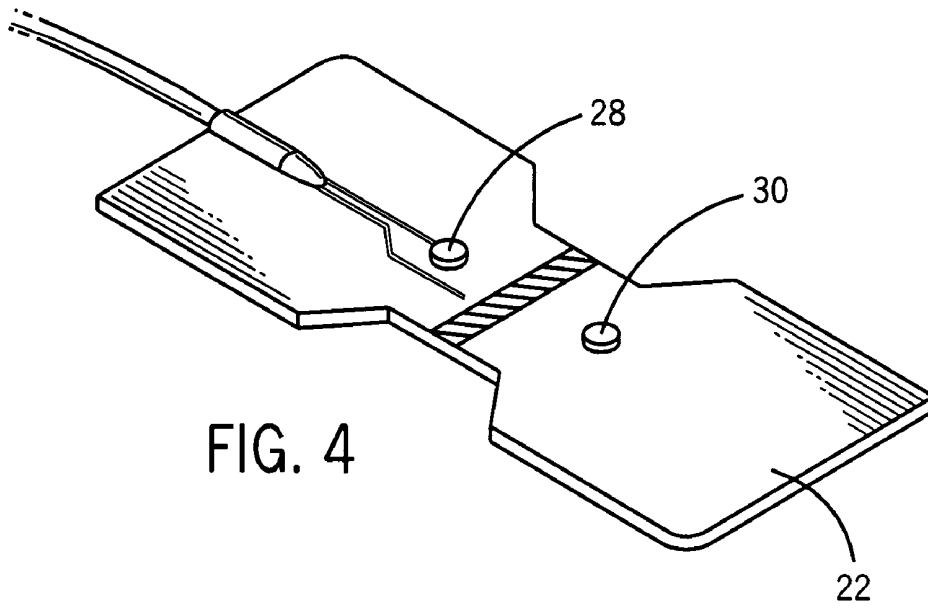

FIG. 3



METHOD FOR IDENTIFICATION OF SENSOR SITE BY LOCAL SKIN SPECTRUM DATA

BACKGROUND OF THE INVENTION

[0001] 1. Field of the Invention

[0002] The present invention relates generally to medical devices and, more particularly, to the determination of the location of and/or calibration of a medical device.

[0003] 2. Description of the Related Art

[0004] This section is intended to introduce the reader to various aspects of art that may be related to various aspects of the present invention, which are described and/or claimed below. This discussion is believed to be helpful in providing the reader with background information to facilitate a better understanding of the various aspects of the present invention. Accordingly, it should be understood that these statements are to be read in this light, and not as admissions of prior art.

[0005] In the field of medicine, doctors often desire to monitor certain physiological characteristics of their patients. For example, to measure certain characteristics, a non-invasive sensor may be utilized that transmits electromagnetic radiation, such as light, through a patient's tissue and then photo-electrically detects the absorption and/or scattering of the transmitted or reflected light in such tissue. The physiological characteristics of interest may then be calculated based upon the amount of light absorbed and/or scattered. In such measurement approaches, the light passed through the tissue is typically selected to be of one or more wavelengths that may be absorbed and/or scattered by one or more constituents of the blood or tissue in an amount correlative to the amount of the constituents present in the blood or tissue. In this manner, the measured amount of light absorbed and/or scattered may then be used to estimate the amount of blood or tissue constituent in the tissue using various algorithms.

[0006] One technique for monitoring the physiological characteristics of a patient is commonly referred to as pulse oximetry, and devices built based upon pulse oximetry techniques are commonly referred to as pulse oximeters. Pulse oximetry may be used to measure various blood characteristics, such as the blood-oxygen saturation of hemoglobin in arterial blood, the volume of blood pulsation supplying the tissue, and/or the rate of blood pulsations corresponding to each heart beat of a patient and/or other cardiovascular parameters of interest. Such physiological information allows doctors and other health care personnel to provide the best possible health care for their patients. Similar techniques may be used to measure tissue hydration. These techniques differ from pulse oximetry primarily in the wavelengths selected for use in the sensor, and in the algorithms used to calculate parameters related to tissue hydration.

[0007] The monitor used with pulse oximetry sensors and other non-invasive sensors are typically calibrated depending on the type of the sensor to ensure maximum accuracy and specificity. Sensors often contain a calibration element, such as a coded resistor or a memory, to provide calibration information to the monitor. For example, a bandage-style pulse oximetry sensor designed for use on the finger of a patient will provide calibration information for that tissue region and sensor type, while an adhesive-type sensor for use on the forehead of a patient will provide different calibration information.

[0008] Unfortunately, technicians or other medical personnel may place a sensor on an inappropriate region, for

example by attempting to use a finger sensor on the forehead, resulting in inaccurate measurements of the physiological characteristic of interest, such as blood oxygen saturation. A bandage-style sensor for use on the finger is typically a transmission-type sensor, in which an emitter and detector are placed on opposing sides of the sensor site. The emitter and detector must therefore have a minimum amount of space between them to accommodate the contours of finger. During operation, the emitter shines one or more wavelengths of light through the patient's finger or other tissue, and light received by the detector is processed to determine the blood oxygen saturation or other desired physiological characteristic of the patient.

[0009] In contrast, an adhesive-style sensor for use on the forehead, while generally operating by the same technique, is a reflectance-style sensor. Reflectance-style sensors include an emitter and detector that are typically placed on the same side of the sensor. The spacing between the emitter and detector in a reflectance-style sensor is typically much smaller than the spacing between the emitter and detector in a transmission style sensor. The light detected by the detector is light scattered back toward the tissue surface and processed to determine blood oxygen saturation or other physiological characteristic. Thus, if a technician misplaces a transmission-type bandage-style sensor intended for use on a finger on the forehead instead, the spacing between the emitter and detector is not optimized for reflectance-type pulse oximetry. Such misplacement could result in inaccurate measurements of blood oxygen saturation or other physiological characteristics.

[0010] Similarly, for tissue hydration assessment, it has been found that the site of sensor placement is important. Particularly, for the purpose of predicting whole body hydration from a local measurement of hydration, knowledge of the site of the sensor placement may critically affect the accuracy of the measurement. For example, placement of the sensor on a body location that is gravitationally above or below the heart, may affect the measurement.

SUMMARY

[0011] Certain aspects commensurate in scope with the originally claimed invention are set forth below. It should be understood that these aspects are presented merely to provide the reader with a brief summary of certain forms of the invention might take and that these aspects are not intended to limit the scope of the invention. Indeed, the invention may encompass a variety of aspects that may not be set forth below.

[0012] There is provided a method for determining the location of a sensor that includes: emitting light into a patient's tissue with at least one emitter disposed on a sensor body; detecting the light with at least one detector disposed on the sensor body; determining a physiological parameter based on the detected light; and determining the location of the sensor based on the parameter.

[0013] There is provided a method for operating a sensor that includes: emitting light into a patient's tissue with at least one emitter; detecting the light with at least one detector; determining a patient-specific physiological parameter wherein the patient-specific physiological parameter comprises at least one of skin color, age, gender, pooled blood, venous blood pulsation, or abnormal tissue; and determining calibration information based on the physiological parameter.

[0014] A sensor assembly is provided. The sensor assembly includes: a sensor body of a spectrophotometric sensor hav-

ing an emitter configured to emit light into a patient's tissue and a detector configured to detect the light; and a monitor. The monitor includes an algorithm configured to determine the location of the sensor based on the detected light.

[0015] There is also provided another sensor assembly, including: a sensor body of a spectrophotometric sensor having an emitter configured to emit light into a patient's tissue and a detector configured to detect the light; and a monitor. The monitor being configured to determine a physiological parameter from the detected light and configured to select at least one emitter from the plurality of the emitters and at least one detector from the plurality of the detectors based on the physiological parameter.

BRIEF DESCRIPTION OF THE DRAWINGS

[0016] Advantages of the invention may become apparent upon reading the following detailed description and upon reference to the drawings in which:

[0017] FIG. 1 depicts an exemplary system with a fiber optic sensor for use in accordance with the present techniques;

[0018] FIG. 2 depicts a cross-sectional view of the fiber optic sensor cable of FIG. 1 taken along line 2-2 in FIG. 1;

[0019] FIG. 3 depicts a pulse-oximetry system with a bandage-style sensor coupled to a patient monitor for use in accordance with the present techniques;

[0020] FIG. 4 depicts a close-up of the bandage-style sensor of FIG. 3 for use on a patient's finger, in accordance with the present techniques; and

[0021] FIG. 5 depicts an adhesive-type medical sensor for use in accordance with the present techniques.

DETAILED DESCRIPTION OF SPECIFIC EMBODIMENTS

[0022] One or more specific embodiments of the present invention will be described below. In an effort to provide a concise description of these embodiments, not all features of an actual implementation are described in the specification. It should be appreciated that in the development of any such actual implementation, as in any engineering or design project, numerous implementation-specific decisions must be made to achieve the developers' specific goals, such as compliance with system-related and business-related constraints, which may vary from one implementation to another. Moreover, it should be appreciated that such a development effort might be complex and time consuming, but would nevertheless be a routine undertaking of design, fabrication, and manufacture for those of ordinary skill having the benefit of this disclosure.

[0023] A number of techniques are presently disclosed. For example, it may be desirable to determine the location of a sensor, such as a pulse oximetry sensor or other sensor utilizing spectrophotometry, so that the location of the sensor may be used to calibrate a monitor coupled to the sensor to improve the accuracy of calculations performed by the monitor. The location of the sensor is determined from location-dependent spectra indicating the water content in the epidermis and the dermis, and the relative thickness of those layers. For example, the forehead and finger have a large variation in respective epidermal thickness and are distinguishable by analyzing spectra from each location. Based on a spectral determination of skin thickness as being indicative of the sensor having been placed on a patient's finger or on a

patient's forehead, a calibration coefficient specific to a finger or forehead may be chosen among those stored on the sensor and sent to a monitor, or the monitor may choose the calibration coefficient based on location information provided by the sensor.

[0024] Further, using a technique described herein, it may also be desirable to determine the skin thickness of a patient at the sensor site without regard to sensor location and to use that determination to calibrate a monitor coupled to the sensor. Instead of selecting a specific sensor location, the monitor may determine skin thickness at the sensor site and select a specific calibration coefficient for that skin thickness. The calibration coefficient may be sent from the sensor to the monitor or it may be selected among those stored on the monitor.

[0025] It also may be desirable to determine other physiological parameters, such as skin color, i.e. skin pigmentation, and to calibrate a monitor coupled to the sensor based on this determination. Skin color of a patient at the sensor site may be determined from the absorption of light in a specific spectral region. The monitor may select a calibration coefficient based on a skin color gradient.

[0026] Additionally, it may be also desirable to determine the approximate age group of the patient and calibrate a monitor coupled to the sensor based on this determination. Some age groups, e.g. neonates, have a relative higher water content and pooled venous blood than adults. The difference in spectra between a neonate and adult may be used by the monitor to select specific calibration coefficients.

[0027] It also may be desirable to identify a patient condition at the sensor site, such as the presence of pooled blood or a tissue edema, and provide a notification to a technician or other medical personnel. Although water content in different layers of the skin is typically responsible for absorption bands in a spectrum of the skin or tissue, other blood or tissue constituents may show absorption bands in various spectral regions. For example, pooled blood at the surface or the skin, or an accumulation of interstitial fluid, e.g. tissue edema, may also show absorption at different spectral regions. A monitor coupled to the sensor may determine the presence of pooled blood or tissue edema and provide the notification.

[0028] A multi-site sensor having multiple emitters and/or detectors at various spacings is also provided. Using the techniques described herein, an optimal emitter-detector combination may be chosen by evaluating the spectral information received from the emitters and detectors. Such a sensor may have one emitter-detector spacing suitable for transmission-based operation, and another emitter-detector spacing suitable for reflectance-based operation, for example. Further, such a sensor may provide calibration coefficients to a monitor based on the determination of physiological parameters such as sensor location, skin thickness, etc. For example, the use of more than one source-detector spacing may also aid in determining the thickness of tissue layers, or help resolve the composition of various layers.

[0029] The embodiments and techniques described herein rely on spectral analysis for determination of various patient-specific or location-specific physiological parameters or conditions, such as water content, epidermal thickness, skin color, tissue edema, etc. Specifically, for example, embodiments and techniques described herein may implement one of the methods for measuring water in tissue by NIR spectroscopy are described in U.S. Pat. No. 6,591,122; U.S. Pub. No. 2003-0220548; U.S. Pub. No. 2004-0230106; U.S. Pub. No.

2005-0203357; U.S. Ser. No. 11/528,154; U.S. Ser. No. 60/857045; U.S. Ser. No. 11/283,506; and U.S. Ser. No. 11/282,947 all of which are incorporated herein by reference. Alternatively, an embodiment of the present invention may implement techniques for measuring the analyte concentrations using spectral bandwidth absorption, as described in U.S. Ser. No. 11/528,154, which is also incorporated herein by reference.

[0030] For simplicity, the spectral analysis for determination of sensor location based on skin thickness and relative water content will be described below. The technique described below is not limited to water content, as determinations of skin thickness, pooled blood, tissue edema, or other patient or location specific physiological parameters or conditions may be performed in a similar manner. Further, the technique described herein is applicable to any spectrophotometric sensor and may be adapted to any applications requiring such a sensor.

[0031] Absorption of various spectral regions reflects the absorption characteristics of different blood and/or tissue constituents and the ability of the light at those spectral regions to penetrate different layers of tissue. Due to the different penetration of light in these spectral regions, the composition and/or thickness of different layers of skin may also be identified from a spectrum of the skin and comparison of relative water absorption bands. For example, light in the spectral region from about 1050 nm to about 1350 nm penetrates into the epidermis and dermis and is therefore useful at determining the composition and/or thickness of the epidermis and dermis. Light in this spectral region will be absorbed by blood and/or tissue constituents that are present in relatively high concentrations in the epidermis and dermis, e.g. water. In contrast, light emitted in the spectral region from about 2000 nm to about 2300 nm is limited to penetration of the stratum corneum layer of the epidermis and is therefore most useful at determining the composition of this layer. However, compared to the lower epidermis and dermis, water content in the stratum corneum is relatively low. Light emitted in the about 1350 to about 1550 nm region has intermediate absorbance between the shorter and longer wavelength regions described above, and is therefore expected to have an intermediate penetration depth. Thus, variations in the intensity ratio between the water absorption band between about 1350 to about 1550 and the water absorption band between about 2000 nm and about 2300 nm can be used to determine the composition and/or thickness of the skin at the measurement site. For example, the stratum corneum is relatively thin at the forehead and cheek, but relatively thick at the finger pad and palm. A spectrum taken at the forehead or cheek will indicate a strong water absorption band in the 1350 to 1550 nm spectral region (relatively high water content in the epidermis and dermis), while a spectrum taken at the finger or palm will indicate a weak water absorption band in the 2000 nm to 2300 nm spectral region (penetration limited to the stratum corneum). Through such an analysis, different spectra may be correlated to specific locations on the body.

[0032] In another example, a particularly sensitive method of determining skin thickness may take advantage of the distinctive absorption peaks of lipids. A layer of subcutaneous fat is located just below the dermis, and the relative absorbance by lipids in this layer is indicative of the relative penetration of light into this layer. Distinctive fat absorption bands are located in the vicinity of about 930 nm, about 1210 nm, about 1720 nm, and about 2300 nm wavelengths. For

example, for detection of dermal thickness in a patient, a source-detector spacing in the range of about 1 mm to about 5 mm and spectral measurement in the about 1700 nm to about 1800 nm range may be selected.

[0033] Further improvement in depth resolution may also be achieved by performing reflectance measurements at more than one source-detector spacing. For example, by comparing absorbance spectra measured at source-detector spacings in the range of about 0.05 mm to about 0.5 mm with spacings in the range of about 1 mm to about 5 mm, the composition of the epidermis and dermis may be respectively determined. Further improvement in the determination of multi-layer tissue composition may be achieved through the combination of both multiple source-detector spacings and multiple spectral regions. For example, a 0.1 mm source-detector separation as described above would be best suited to spectral measurements in the range of about 1800 nm to about 2500 nm, where tissue absorbance is high.

[0034] It should be appreciated that exemplary steps of the present technique are typically implemented in a sensor and a patient monitoring system. In accordance with some aspects of the present technique, reusable medical sensors and patient monitors are provided and configured to determine patient-specific physiological parameters.

Fiber Optic Sensor and Calibration of a Monitor Based on Skin Location

[0035] Referring now to FIG. 1, a system 10 depicting a fiber optic sensor 12 used in conjunction with a monitor 14 is shown. In the depicted embodiment, a sensor cable 16 connects the sensor 12 to the monitor 14 through a connector 17. The sensor cable 16 is typically used to transmit light, control and/or timing signals from the monitor 14 to the sensor 12 and/or to transmit acquired data from the sensor 12 to the monitor 14. The sensor 12 and/or the sensor cable 16 may include or incorporate one or more integrated circuit devices or electrical devices, such as a memory, processor chip, or resistor that may facilitate or enhance communication between the sensor 12 and the monitor 14.

[0036] The sensor cable 16 may contain multiple optic fibers 18 and a central detector fiber 20 as shown in the cross-section of sensor cable 16 taken along line 2-2 as illustrated in FIG. 2. The monitor 14 may contain one or more emitters that emit light through the optic fibers 18. In the exemplary system shown, the emitters used are multiple light emitting diodes (LEDs) or any other kind of emitter that emits light in the desirable wavelengths. Alternatively, the emitter may be a source capable of emitting across a broad range of wavelengths, such as a tunable laser. Each optic fiber 18 may connect to one LED, and a filter may be interposed between each LED and optic fiber 18. Regulation of the desired wavelength of light transmitted to the sensor and into the patient's tissue may be accomplished through the selection of LEDs as well as the filters between the LEDs and the optic fibers 18.

[0037] The fiber optic sensor 12 may be placed on a single location on a patient's body and the monitor 14 or the sensor 12 may correlate the spectrum to different locations on the body by analyzing different spectral regions. Specifically, the sensor 12 may be placed on a patient's finger, and a blood oxygen saturation measurement may be taken using the red and infrared spectral regions typical of pulse oximetry. In alternative applications, the sensor 12 may be placed on multiple locations of a patient's body to test for other conditions, such as tissue hydration, for example.

[0038] As discussed above, the spectral absorption regions vary according to different blood or tissue constituents and depth of penetration of light in those regions. For example, the relative water absorption bands of different spectral regions may be used to determine epidermal and dermal composition and/or thickness, and therefore sensor location. Accordingly, in addition to the red and infrared spectral regions, the system **10** and fiber optic sensor **12** may be configured to transmit light in the following regions: from about 1050 nm to about 1350 nm; from about 1550 nm to about 1850 nm, and/or from about 2000 nm to about 2300 nm. Variations in the water and fat absorption bands in these spectral regions can be analyzed to determine skin thickness and, therefore, sensor location. A thicker epidermis may indicate a sensor location of a finger, whereas a thinner epidermis may indicate a sensor location of a forehead. Calibration information for the monitor **14**, such as calibration coefficients, is selected based on the determination of the sensor location. Calibration coefficients may be stored in a memory on the sensor **12**, or they may be stored in the monitor **14** and selected based on information sent from the sensor **12** to the monitor **14**. Calibration coefficients may be stored for any number of sensor locations, e.g., the forehead, the finger, the cheek, etc.

[0039] Once the monitor is calibrated according to the specific sensor location, the blood oxygen saturation may be determined. The calibration of the monitor **14** for the specific sensor location increases the accuracy and specificity of the monitor's blood oxygen saturation determination.

Fiber Optic Sensor and Calibration of a Monitor Based on Skin Thickness

[0040] Accuracy of the system **10** and fiber optic sensor **12** described above may be increased by calibration of the monitor **14** coupled to the sensor **12** according to a determination of skin thickness. In this embodiment, the system **10** and fiber optic sensor **12** operate according to the techniques described above, and may provide additional wavelengths in the following regions: from about 1050 nm to about 1350 nm; from about 1550 nm to about 1850 nm, and from about 2000 nm to about 2300 nm. Methods and algorithms for determining fluid parameters are disclosed in U.S. Pub. No. 2004-0230106, and methods and algorithms for estimating tissue hydration from spectral absorption bandwidth measurements are disclosed in U.S. Ser. No. 11/528,154, both of which have been incorporated herein by reference. Using the relative water absorption bands in these spectral regions, the thickness of the skin may be determined. Instead of correlating the thickness of the skin to a sensor location, however, calibration information may be chosen based on the skin thickness without regard to sensor location. For example, calibration coefficients, either stored in the sensor **12** in a memory or stored in the monitor **14**, may be selected along a variable calibration curve, depending on the thickness of the skin, as opposed to discrete locations such as a finger, forehead, etc.

[0041] Once the monitor is calibrated according to the specific skin thickness at the sensor site, the blood oxygen saturation may be determined. The calibration of the monitor for

the specific skin thickness at the sensor location increases the accuracy and specificity of the monitor's blood oxygen saturation determination.

Fiber Optic Sensor and Calibration of a Monitor Based on Skin Color

[0042] Again referring to the exemplary system **10** and fiber optic sensor **12** of FIG. 1, in some embodiments the calibration information used by the monitor may be chosen based on a determination of skin color of the patient at the sensor site, e.g. skin pigmentation. Some wavelengths of light emitted by the optic fibers **18** may be affected by the amount and type of melanin or carotene in the skin. In situations of low blood oxygen saturation, for example, skin color has a relatively larger effect on the accuracy of the blood oxygen saturation determination as compared to patients with normal levels of blood oxygen saturation.

[0043] In this embodiment the system **10** and the fiber optic sensor **12** operate according to the techniques described above, and may provide additional wavelengths in the following region: from about 400 nm to about 800 nm. Absorption bands in this spectral region may indicate higher concentrations of melanin (darker skin) or lower concentrations of melanin (lighter skin). Calibration coefficients may be selected based on this determination, and the selection may depend on the on the complexity of the spectral analysis. For example, the selection of calibration coefficients may be based on a threshold, in which melanin concentrations indicative of a skin color darker than the threshold result in selection of one set of calibration coefficients. Conversely, melanin concentrations indicative of a skin color lighter than the threshold result in the selection of a different set of calibration coefficients. In alternate embodiments, instead of a discrete selection based on a threshold value, the calibration coefficients may be selected for ranges of skin color as represented by gradual changes in melanin concentration. Again, calibrating the monitor according to skin color/pigmentation can result in increasing the accuracy and specificity of the monitor's blood oxygen saturation determination, especially in patient's experiencing low levels of blood oxygen saturation.

Fiber Optic Sensor and Calibration of a Monitor Based on Age Group

[0044] In other embodiments, the calibration information used by the monitor **14** in the system **10** depicted in FIG. 1 may be chosen based on a determination of the age group of the patient, e.g. whether the patient is a neonate or an adult. In determining the age group of the patient, spectral regions that are indicative of water content and pooled blood are most useful. For example, neonates typically have higher relative water content and pooled blood than adults. A spectrum of the skin of a neonate will show different peak water absorption bands and different peak bands at wavelengths of light susceptible to pooled blood absorption.

[0045] As in the above embodiments, the system **10** and fiber optic sensor **12** operate according to the techniques described above, for example by using the red and infrared to determine blood oxygen saturation. The monitor **14** and fiber optic sensor **12** may provide additional wavelengths in the following regions: 510 nm (useful for identifying pooled blood); from about 1050 nm to about 1350 nm; from about 1550 nm to about 1850 nm; and from about 2000 nm to about 2300 nm (useful in identifying water content in different

layers of skin). The spectral analysis of these spectral regions may show absorption bands that can be used to determine if the patient is likely to be a neonate or an adult. For example, water absorption bands in the spectral region from about 2000 nm to about 2300 nm may indicate higher relative water content in comparison to a spectrum taken from an adult. Similarly, peak absorption bands around the 510 nm spectral region may indicate pooled blood at the sensor site. Thus, from a combination of these two indicators, the monitor may make a determination that the patient is a neonate and send this information to the monitor. The monitor may store different calibration coefficients specific to neonates or adults and make a selection based on the sensor determination. Alternatively, the sensor 12 can store calibration coefficients in a memory, and the monitor can select a calibration coefficient based on the age group of the patient, and then the sensor can send the appropriate selected calibration coefficient to the monitor 14.

[0046] Alternatively, steady-state (as opposed to photoplethysmographic) measurement of the tissue absorbance using standard pulse-oximetry wavelengths such as 660 nm and 890 nm, i.e. red and near infrared wavelengths, may also be useful as an indication of the amount of pooled blood at the measurement site. Advantageously, implementation of such a technique would require no change to the sensor except that calibration for the LED intensity output may be required. Such calibration could be readily accomplished through a separate measurement on a standard scattering material such as Teflon.

Bandage-Style Pulse Oximetry Sensor and Identification of Patient Conditions

[0047] Turning now to FIG. 3, a system 20 for use in conjunction with a conventional bandage-style pulse oximetry sensor 22 or the adhesive-style sensor is shown. A monitor 26 is shown connected to an bandage-style sensor 22 through a sensor cable 24. The sensor cable 24 of the sensor 22 may be directly coupled to a pulse oximetry monitor 26, or it may be coupled to a transmission device (not shown) to facilitate wireless transmission between the sensor 22 and the monitor 26. The sensor cable 24 is responsible for transmitting electrical and/or optical signals to and from the emitter 28 and detector 30 of the sensor 22. The monitor 26 may be any suitable pulse oximeter, such as those available from Nellcor Puritan Bennett Inc. Furthermore, to upgrade conventional pulse oximetry provided by the monitor 26 to provide additional functions, the monitor 26 may be coupled to a multi-parameter patient monitor 32 via a cable 34 connected to a sensor input port or via a cable 36 connected to a digital communication port.

[0048] A close-up of the exemplary bandage-style sensor 22 is shown in FIG. 4. The exemplary sensor 22 includes an emitter 28 and a detector 30 which may be of any suitable type. For example, the emitter 28 may be one or more LEDs adapted to transmit one or more wavelengths of light, such as in the visible light or red to infrared range, and the detector 30 may be one or more photodetectors, such as a silicon photodiode package, selected to receive light in the range emitted from the emitter 28. The type and number of detectors 30 present in the sensor 22 may depend on how many and what wavelengths are emitted by the emitter 28. In a conventional pulse-oximetry sensor, the emitter 28 emits light only in the red and infrared range. The exemplary sensor 22 has been modified from a conventional pulse-oximetry sensor so that

the emitter 28 may emit one or more wavelengths in addition to those used in pulse oximetry, such as through the addition of another LED.

[0049] The additional wavelengths of light emitted by emitter 28 are used to determine one or more patient-specific conditions. For example, a green LED, emitting light at wavelengths about 510 nm, may be added to identify pooled blood underneath the skin. In other embodiments, an LED emitting light at a wavelength of about 980 nm can be used to identify interstitial fluid, and therefore tissue edema, in the underlying tissue. Other LED's may be used depending on the blood or tissue constituent of interest. Regardless of the LED and additional wavelengths chose, operation of the sensor 22 and detection of the transmitted light is similar to conventional pulse oximetry and the spectral analysis described above. The sensor 22 is placed on a patient, for example on a patient's finger, and then light is emitted by the emitter 28, transmitted through the patient's tissue, and then received by the detector 30. The monitor 26 receives signals from the detector 30 and determines blood oxygen saturation from the ratio of the light absorbed emitted at the red and infrared wavelengths. In the exemplary system 20, the monitor 26 also receives signals based on the detected light at the additional wavelengths, for example at about 510 nm for example. The absorption of light at this additional wavelength, such as a peak absorption band around this region, may indicate pooled blood at the sensor site. If the monitor 26 determines there is such a peak absorption band in the spectral region, then the monitor 26 may provide an audio or visual notification. A technician may then take any necessary actions, such as relocating the sensor to a site less affected by the presence of pooled blood. Similar actions may be taken by the monitor 26 if the additional wavelengths emitted provide an indication of tissue edema or other conditions that may affect accuracy of the sensor.

Sensor with Multiple Emitters and Detectors

[0050] FIG. 5 illustrates an exemplary adhesive-type medical sensor 40 with multiple emitters and detectors for use in pulse oximetry or other spectrophotometric applications. The sensor 40 may be used in the system 20 depicted in FIG. 3 and connected to a monitor 26 by a sensor cable 41. The sensor cable 41 is responsible for transmitting electrical and/or optical signals to and from the emitters 42 and detectors 44 of the sensor 41.

[0051] The exemplary sensor 40 has two emitters 42A and 42B and three detectors 44A, 44B, and 44C, but any number of emitters and detectors may be used. The emitters and detectors are spaced inline along the body of the sensor 40, with emitters 42A and 42B grouped together and the three detectors 44A, 44B, and 44C grouped together. In alternate embodiments the spacing between the emitters and detectors and the number of emitters or detectors may vary according to the size of the sensor 40 and the desired spectrophotometric application, e.g. reflectance-based or transmission-based operation. The emitters 42A and 42B may be one or more LEDs adapted to transmit one or more wavelengths of light, such as in the red to infrared range, and the detectors 44A, 44B, and 44C may be one or more photodetectors, such as a silicon photodiode package, selected to receive light in the range emitted from the emitters 42A and 42B.

[0052] Operation of the sensor 40 may include emission of different wavelengths of light and detection and analysis of the absorption of those wavelengths to determine blood oxygen saturation, water content and skin composition and thickness, and to determine optimal emitter-detector combina-

tions. For example, emitter 42B may emit red and infrared wavelengths for determining blood oxygen saturation. Emitter 42A may emit wavelengths in the spectral regions useful for quantification of water content at different layers of the skin: from about 1050 nm to about 1350 nm; from about 1550 nm to about 1850 nm; and/or from about 2000 nm to about 2300 nm. The detectors 46A, 46B, and 46C may detect any or all of the emitted wavelengths of light as they are transmitted or reflected through the patient's skin or tissue. Further, the sensor may send calibration information to the monitor depending on the determinations of water content, skin thickness, skin composition, etc., as described above.

[0053] Additionally, the monitor 26 may select an optimal emitter-detection combination from the emitters 42A and 42B and detectors 44A, 44B, and 44C available on the sensor. The optimal emitter-detector combination may be that combination best arranged for reflectance-based operation or transmission-based operation, depending on the sensor location. Alternatively, the optimal emitter-detector combination may be that combination least susceptible to perturbations, i.e. the presence of venous pulsation or a large artery. It may also be the emitter-detector combination with the appropriate distance for the depth and/or specific optical properties of the tissue of interest, i.e. a closer emitter-detector spacing may be more appropriate for darker skin because of the absorptive characteristics of melanin.

[0054] During operation of the sensor, the monitor may receive signals of varying quality from detectors 44A, 44B, and 44C. For example, if the sensor 40 is applied to the finger as a bandage-style sensor, then emitter 42B and detector 44C are spaced on opposite sides of the finger. This arrangement is optimal for transmission-based operation. In contrast, detector 44A will be near the top of the finger, spaced relatively close to emitters 42A and 42B, in an arrangement suitable for reflectance-based operation. However, the thickness of the skin at the finger may inhibit the effectiveness of reflectance-type operation at that sensor site, and detector 44A may receive minimal reflected light from the emitters 42A and 42B, and therefore may transmit a poor quality signal to the monitor. Alternatively, if the sensor 40 is applied to the forehead, then all emitters and detectors are on the same side of the sensor site. In this application, light received at the detectors 44A, 44B, and 44C will be reflected from the skin, and the emitter-detector pairing that provides the best spacing for reflectance-based operation is optimal. In this case, emitter 42B and detector 44A are spaced in an arrangement best suited for reflectance-type operation, i.e. minimal space between the emitter 42B and detector 44A relative to the other emitter-detector spacings. The optimal source-detector spacing for reflectance may be chosen based on a balance among the following factors: (1) minimizing light shunting, i.e. LED light that reaches the detector without penetrating to the blood layer, by increasing the source-detector spacing; (2) maximizing the size of the plethysmographic signal relative to the steady-state signal by increasing source-detector spacing; (3) maximizing the signal to noise ratio of the plethysmograph signal by using an intermediate source-detector spacing; and (4) minimizing sensitivity to subject-to-subject scattering variations by optimizing at intermediate source-detector spacing.

[0055] Once the optimal emitter-detector pairing is selected, the monitor 26 may determine blood oxygen saturation from the absorption of the red and infrared light. Alternative embodiments may provide use of multiple emitter-

detector pairings, for example use of the detected light from all three detectors 44A, 44B, and 44C, and determine blood oxygen saturation based on an average or other weighted calculation.

[0056] The technique described herein may be used in additional sensor embodiments. For example, a multi-site adhesive-type sensor similar to the sensor described in FIG. 4 may be used, in which the appropriate spectral regions that serve as indicators of epidermal and dermal composition and/or thickness could be used to determine the location of the sensor. The location of the sensor can then be used to select the appropriate calibration information and/or algorithm for that particular location, as outlined in the techniques described above.

[0057] While the invention may be susceptible to various modifications and alternative forms, specific embodiments have been shown by way of example in the drawings and have been described in detail herein. However, it should be understood that the invention is not intended to be limited to the particular forms disclosed. Rather, the invention is to cover all modifications, equivalents, and alternatives falling within the spirit and scope of the invention as defined by the following appended claims. Indeed, the present techniques may not only be applied to transmission type sensors for use in pulse oximetry, but also to reflectance type sensors, other sensor designs, and measurement of other physiological characteristics such as tissue hydration. Likewise, the present techniques are not limited to any specific location on a patient but may be applied to placement on any body part.

What is claimed is:

1. A method for determining the location of a sensor, comprising:
 - emitting light into a patient's tissue with at least one emitter disposed on a sensor body;
 - detecting the light with at least one detector disposed on the sensor body;
 - determining a physiological parameter based on the detected light; and
 - determining the location of the sensor based on the parameter.
2. The method of claim 1, comprising determining calibration information based on the location of the sensor.
3. The method of claim 1, wherein the physiological parameter comprises water content.
4. The method of claim 1, wherein the physiological parameter comprises epidermal thickness.
5. The method of claim 1, wherein the physiological parameter comprises dermal thickness.
6. The method of claim 1, wherein the location of the sensor is the forehead of the patient.
7. The method of claim 1, wherein the location of the sensor is the finger of the patient.
8. The method of claim 1, wherein the sensor is a pulse oximetry sensor.
9. The method of claim 1, wherein the sensor is a fiber optic sensor.
10. A method of operating a sensor, comprising:
 - emitting light into a patient's tissue with at least one emitter;
 - detecting the light with at least one detector;
 - determining a patient-specific physiological parameter based on the detected light, wherein the patient-specific physiological parameter comprises at least one of skin color, age, gender, pooled blood, venous blood pulsation, or abnormal tissue; and

determining calibration information based on the patient-specific physiological parameter.

11. The method of claim **10**, comprising determining blood oxygen saturation from the detected light.

12. The method of claim **10**, wherein the abnormal tissue comprises tissue edema.

13. The method of claim **10**, comprising providing a notification based on the patient-specific physiological parameter.

14. The method of claim **10**, comprising selecting one emitter and one detector based on the patient-specific physiological parameter.

15. The method of claim **10**, wherein the sensor is a pulse oximetry sensor.

16. The method of claim **10**, wherein the sensor is a fiber optic sensor.

17. A sensor assembly, comprising:

a sensor body having an emitter configured to emit light into a patient's tissue and a detector configured to detect the light; and

a monitor comprising an algorithm configured to determine the location of the sensor based on the detected light.

18. The assembly of claim **17**, wherein the monitor comprises an algorithm configured to determine calibration information based on the location of the sensor.

19. The assembly of claim **17**, wherein the sensor assembly is configured to measure blood oxygen saturation.

20. The assembly of claim **17**, wherein the emitter comprises optic fibers.

21. A sensor assembly, comprising:

a sensor body having a plurality of emitters configured to emit light into a patient's tissue and a plurality of detectors configured to detect the light; and

a monitor comprising being configured to determine a physiological parameter from the detected light and configured to select at least one emitter from the plurality of the emitters and at least one detector from the plurality of the detectors based on the physiological parameter.

* * * * *

专利名称(译)	通过局部皮肤光谱数据识别传感器部位的方法		
公开(公告)号	US20080221410A1	公开(公告)日	2008-09-11
申请号	US11/716264	申请日	2007-03-09
[标]申请(专利权)人(译)	内尔科尔普里坦贝内特公司		
申请(专利权)人(译)	NELLCOR PURITAN BENNETT LLC		
当前申请(专利权)人(译)	COVIDIEN LP		
[标]发明人	CAMPBELL SHANNON E DEBRECZENY MARTIN P HOARAU CARINE		
发明人	CAMPBELL, SHANNON E. DEBRECZENY, MARTIN P. HOARAU, CARINE		
IPC分类号	A61B5/00		
CPC分类号	A61B5/0059 A61B5/14551 G01N21/474 A61B5/1495 A61B5/443 A61B5/14552		
其他公开文献	US8346327		
外部链接	Espacenet USPTO		

摘要(译)

提供了一种用于确定传感器位置的方法。该方法包括基于检测到的光确定生理参数并基于生理参数确定传感器的位置。另外，提供了一种用于操作传感器的方法，该方法包括基于患者特异性生理参数校准传感器，其中患者特异性生理参数是皮肤颜色，年龄，性别，合并血液，静脉血液脉动或异常。组织。

