



(19) **United States**

(12) **Patent Application Publication**

Lurie et al.

(10) **Pub. No.: US 2002/0069878 A1**

(43) **Pub. Date: Jun. 13, 2002**

(54) **APPARATUS AND METHODS FOR ENHANCING CARDIOPULMONARY BLOOD FLOW AND VENTILATION**

now patented, which is a continuation-in-part of application No. 08/149,204, filed on Nov. 9, 1993, now patented.

(75) Inventors: **Keith G. Lurie**, Minneapolis, MN (US); **Todd M. Zielinski**, Minneapolis, MN (US)

Publication Classification

(51) **Int. Cl.⁷** **A62B 7/00**; A62B 9/00
(52) **U.S. Cl.** **128/204.18**; 128/200.24

Correspondence Address:
TOWNSEND AND TOWNSEND AND CREW, LLP
TWO EMBARCADERO CENTER
EIGHTH FLOOR
SAN FRANCISCO, CA 94111-3834 (US)

(57) **ABSTRACT**

According to the invention, methods and devices for increasing cardiopulmonary circulation induced by chest compression and decompression when performing cardiopulmonary resuscitation are provided. According to one method, a pressure responsive inflow valve is coupled to a patient's airway. Chest compressions and chest decompressions are performed. During chest decompression the inflow valve prevents respiratory gases from entering the lungs until a certain negative intrathoracic pressure level is exceeded at which time the one inflow valve opens. In this way, the inflow valve assists in increasing the magnitude and duration of negative intrathoracic pressure during decompression to enhance the amount of blood flow into the heart and lungs. Further, the patient is supplied with a pressurized respiratory gas through the inflow valve when the inflow valve opens to ventilate the patient.

(73) Assignee: **CPRx LLC**, Minneapolis, MN

(21) Appl. No.: **09/854,238**

(22) Filed: **May 11, 2001**

Related U.S. Application Data

(63) Continuation-in-part of application No. 09/546,252, filed on Apr. 10, 2000, which is a continuation of application No. 08/950,702, filed on Oct. 15, 1997, now patented, which is a continuation-in-part of application No. 08/403,009, filed on Mar. 10, 1995,

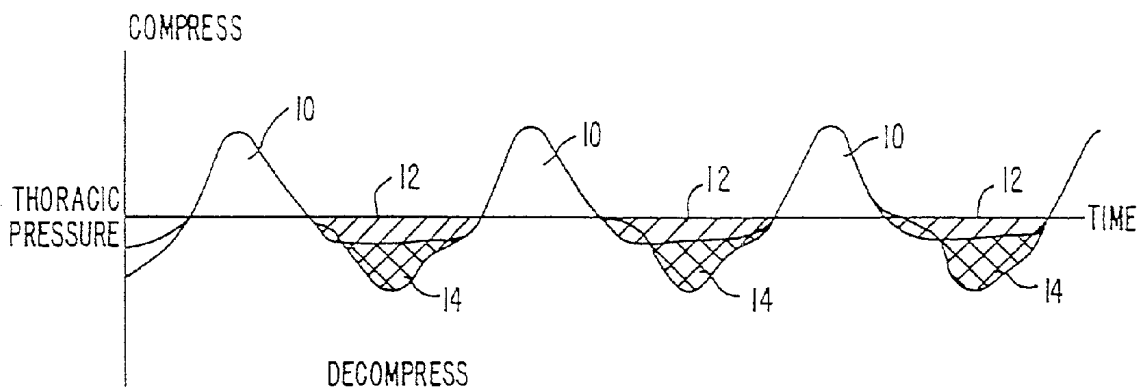

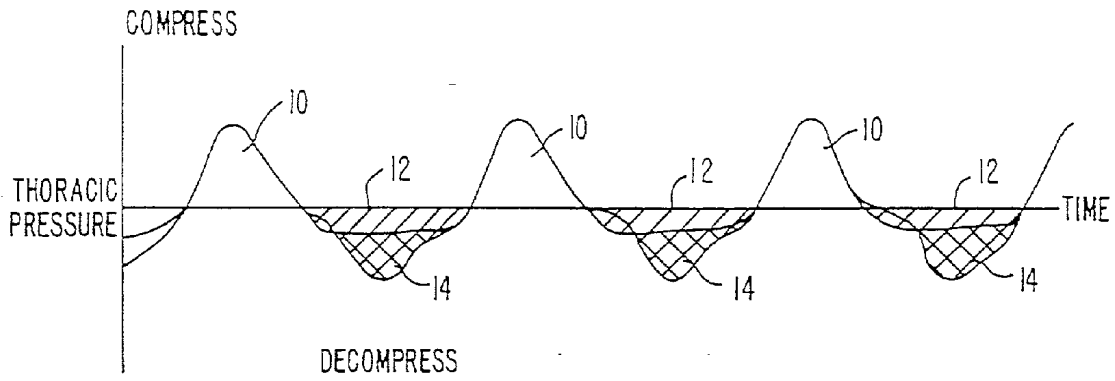

FIG. 1.

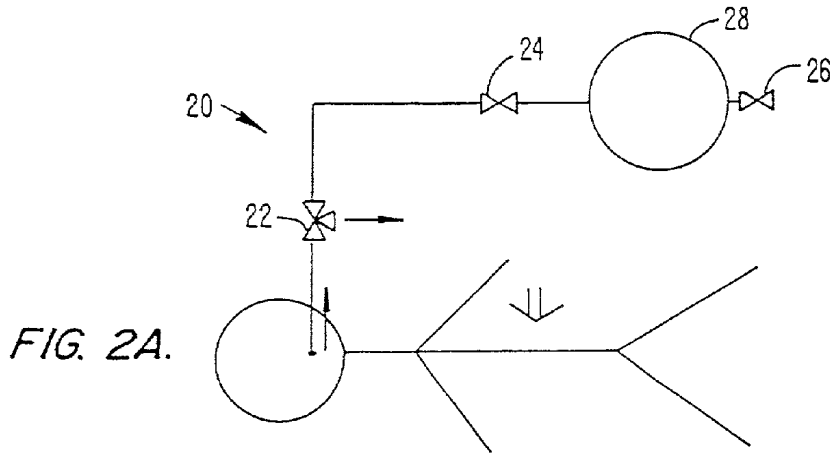

FIG. 2A.

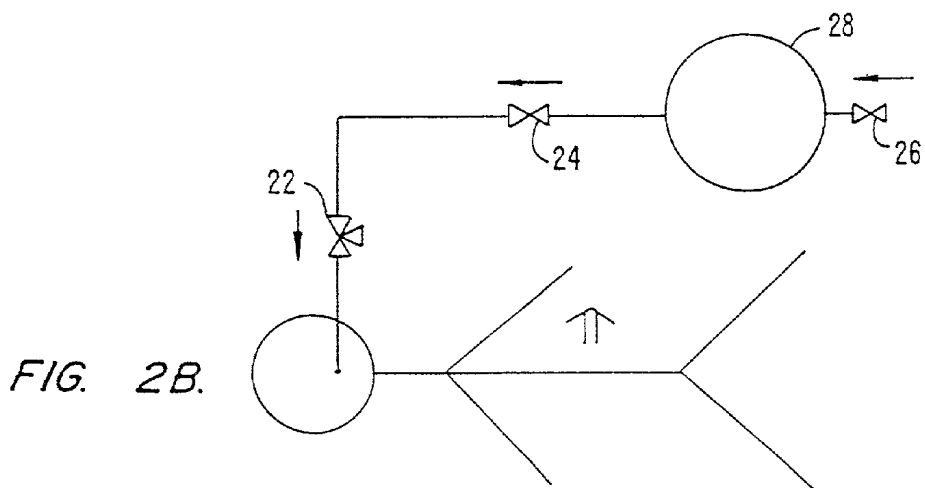

FIG. 2B.

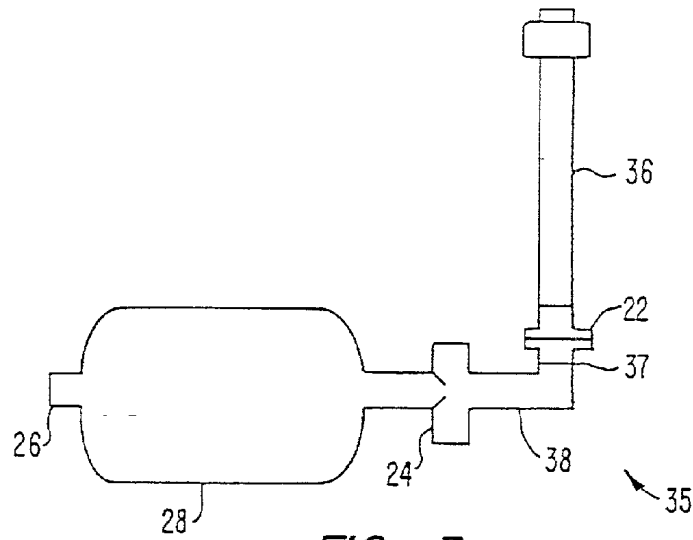

FIG. 3.

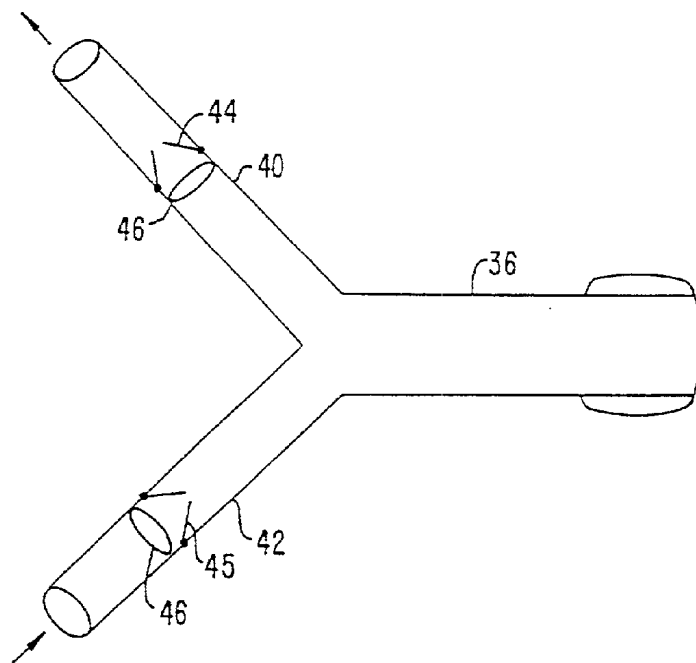

FIG. 4A.

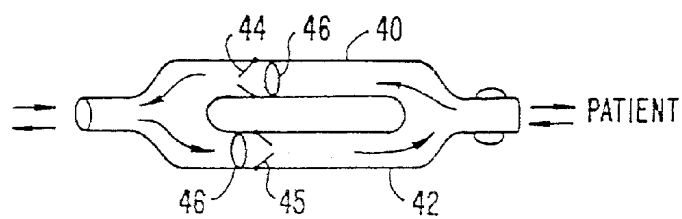

FIG. 4B

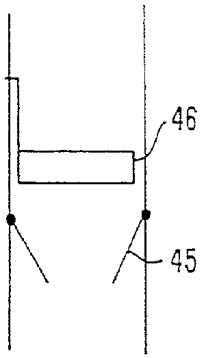

FIG. 5A.

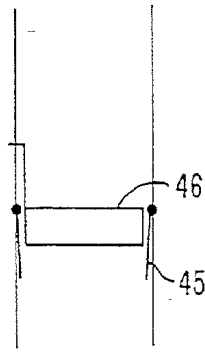

FIG. 5B.

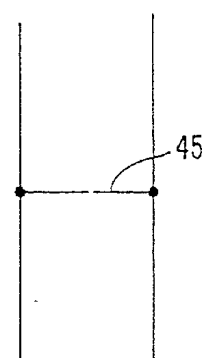

FIG. 5C.

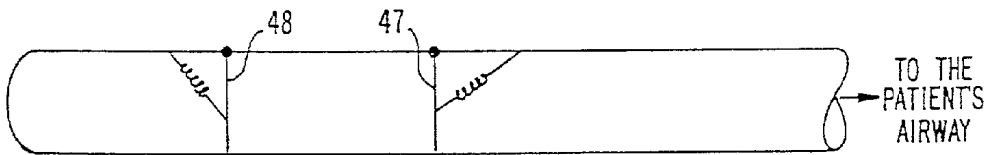

FIG. 6A.

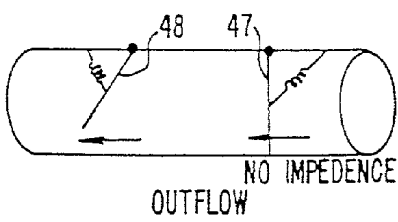

FIG. 6B.

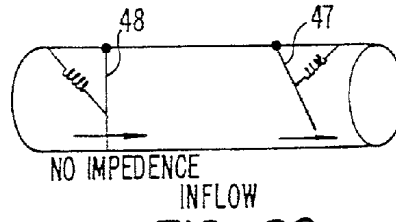

FIG. 6C.

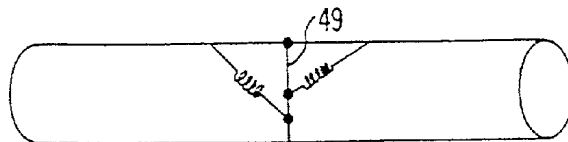

FIG. 7.

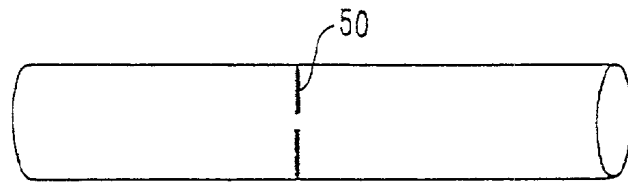

FIG. 8.

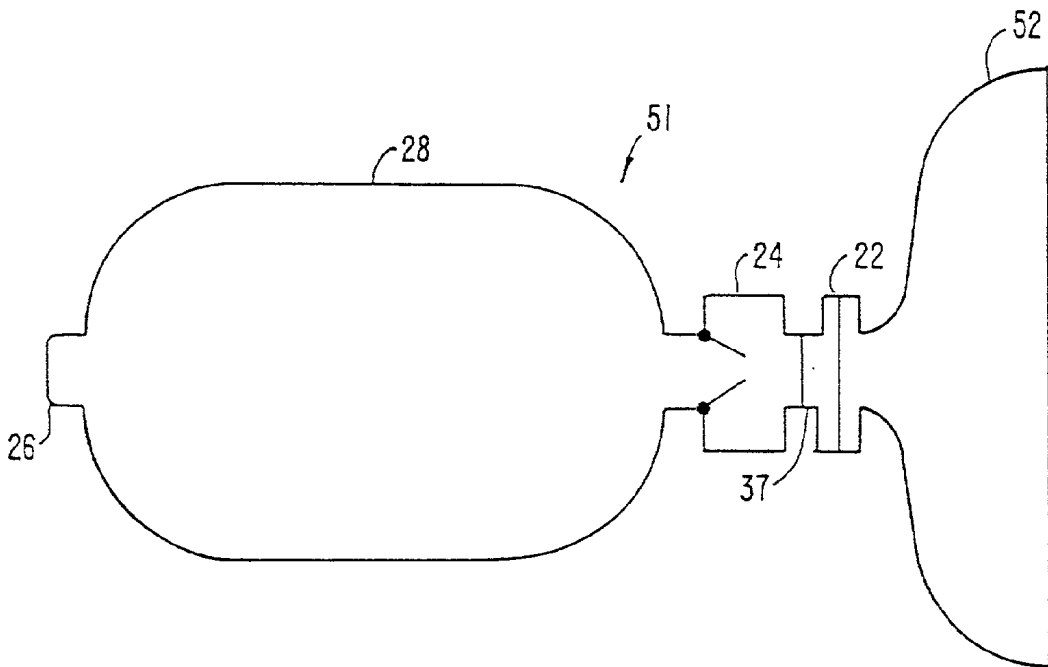

FIG. 9.

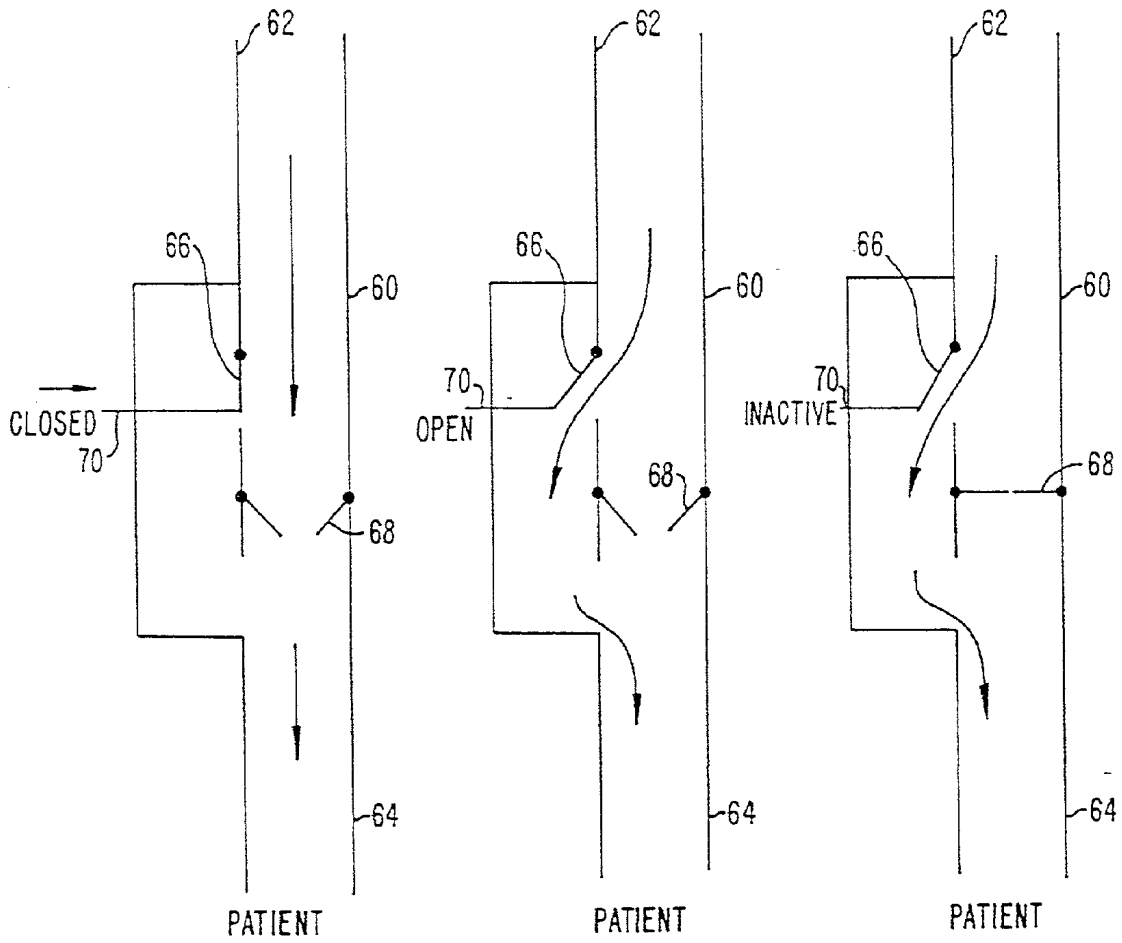

FIG. 10A.

FIG. 10B.

FIG. 10C.

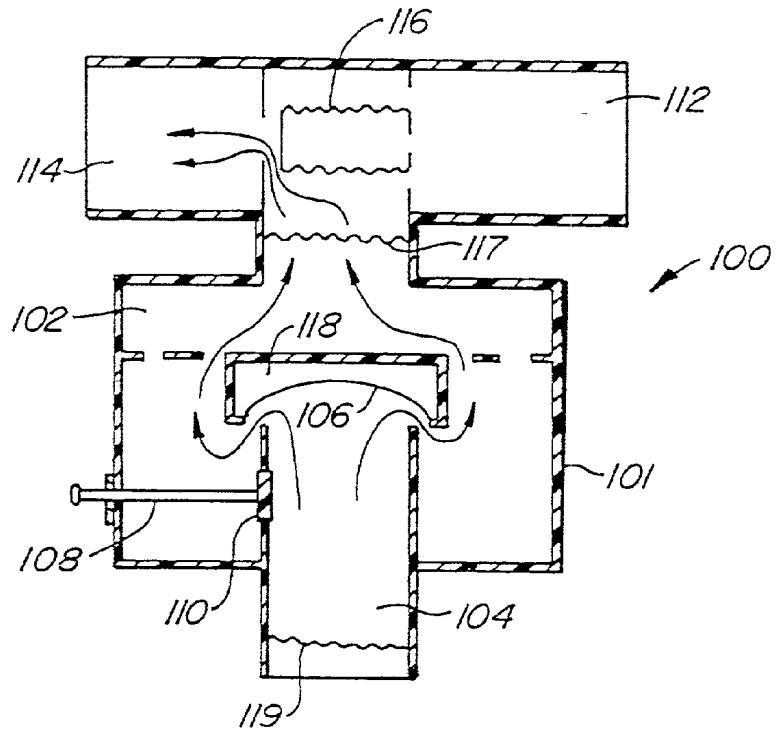

FIG. 11.

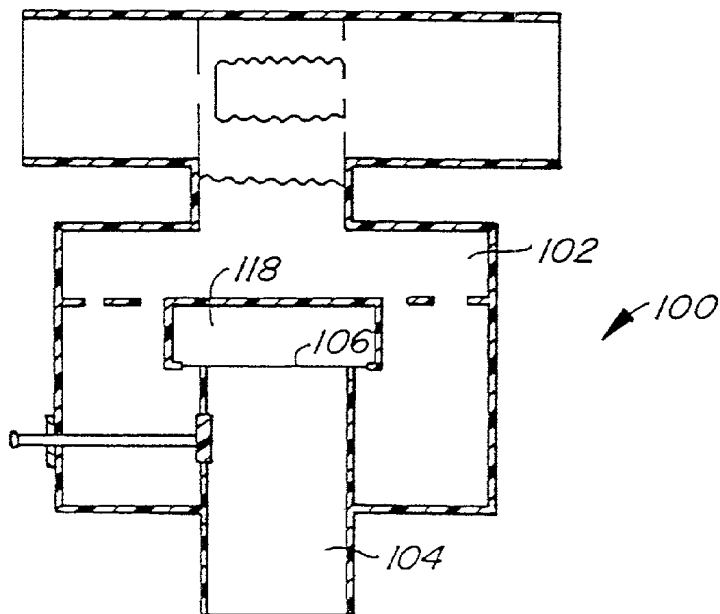

FIG. 12.

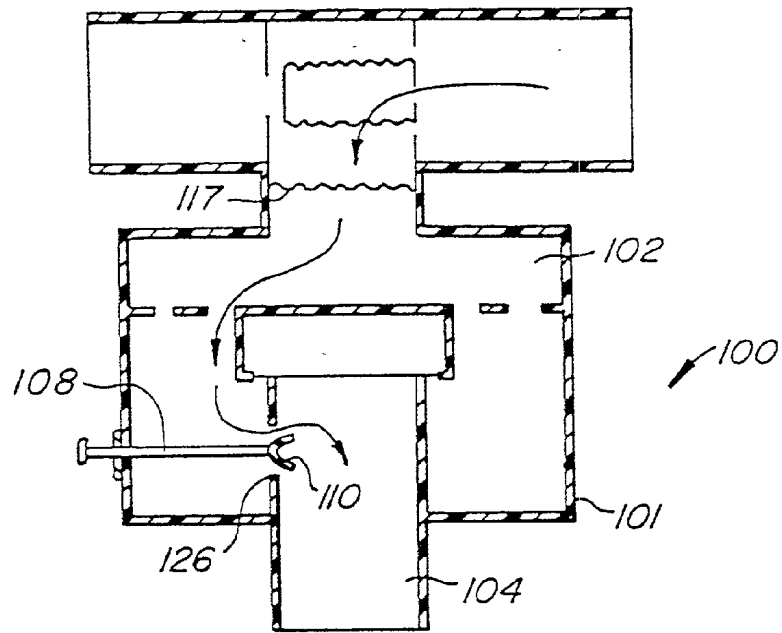

FIG. 13.

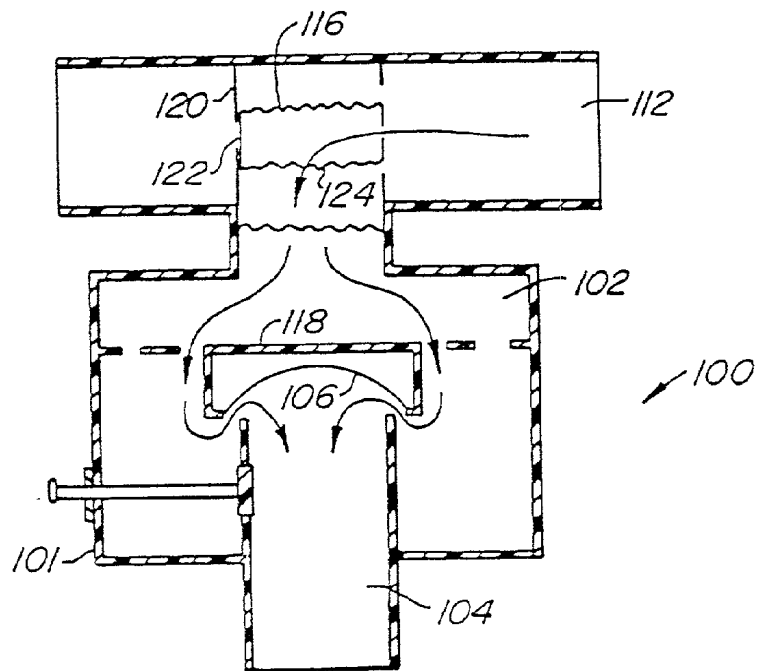

FIG. 14.

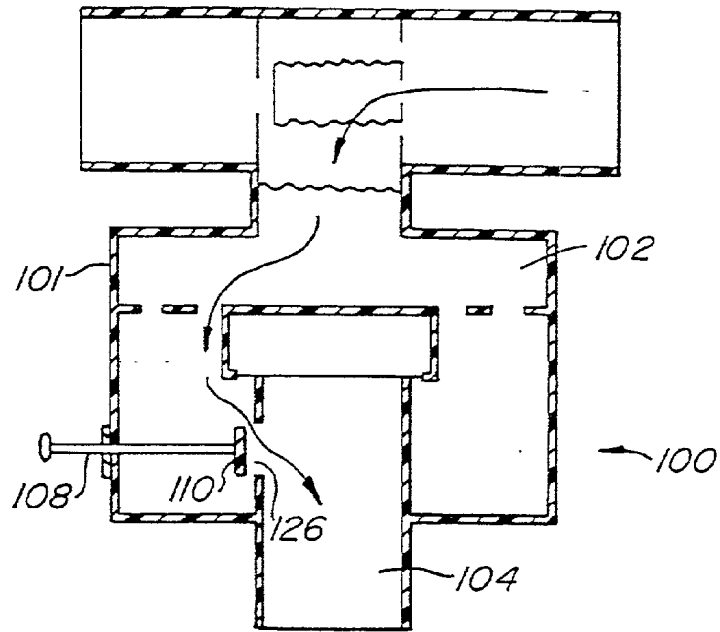

FIG. 15.

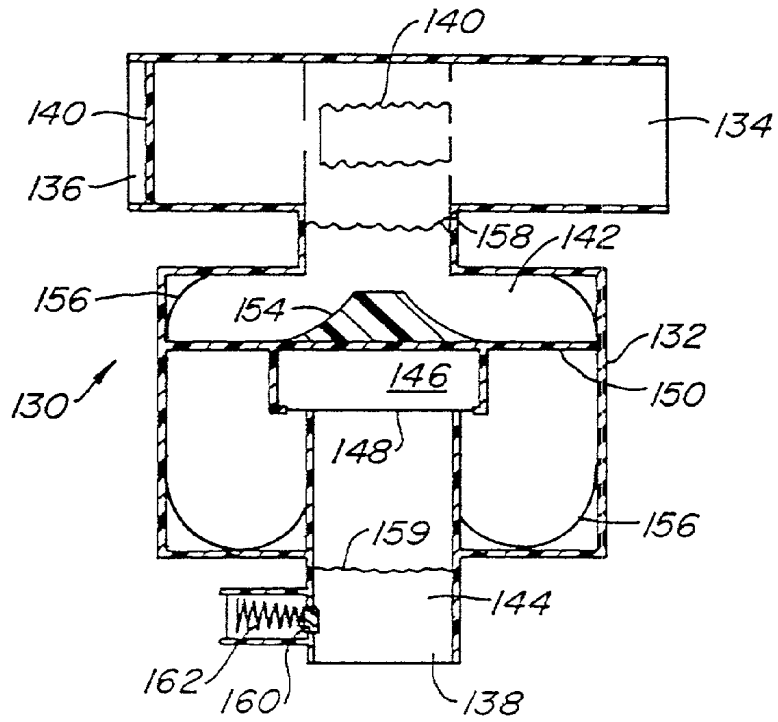

FIG. 16A.

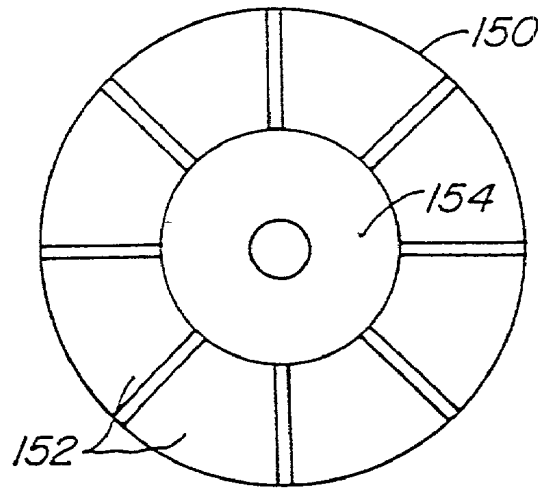

FIG. 16B.

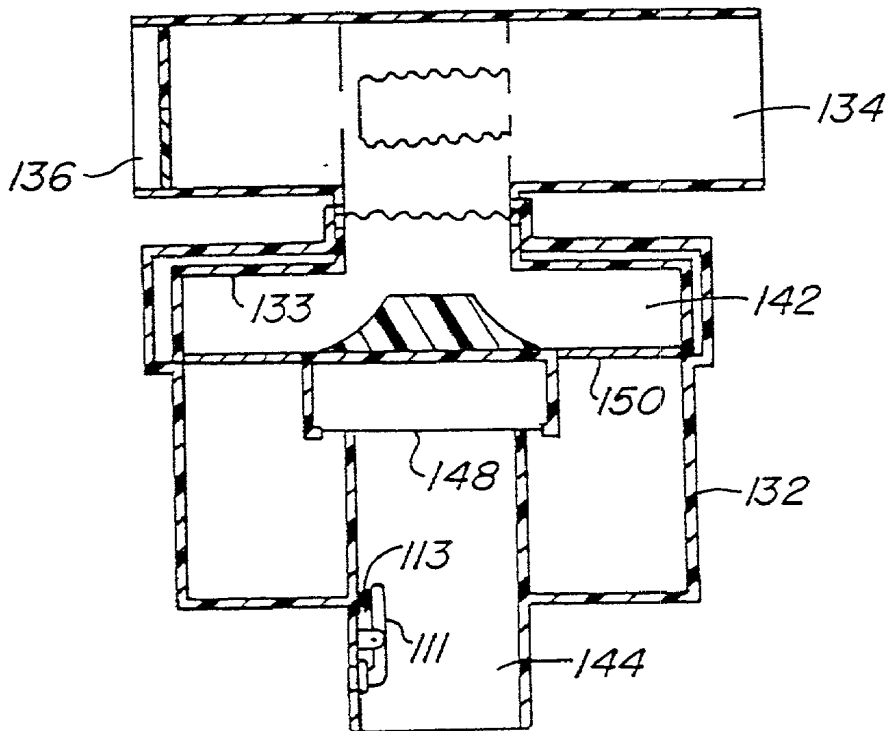

FIG. 16C.

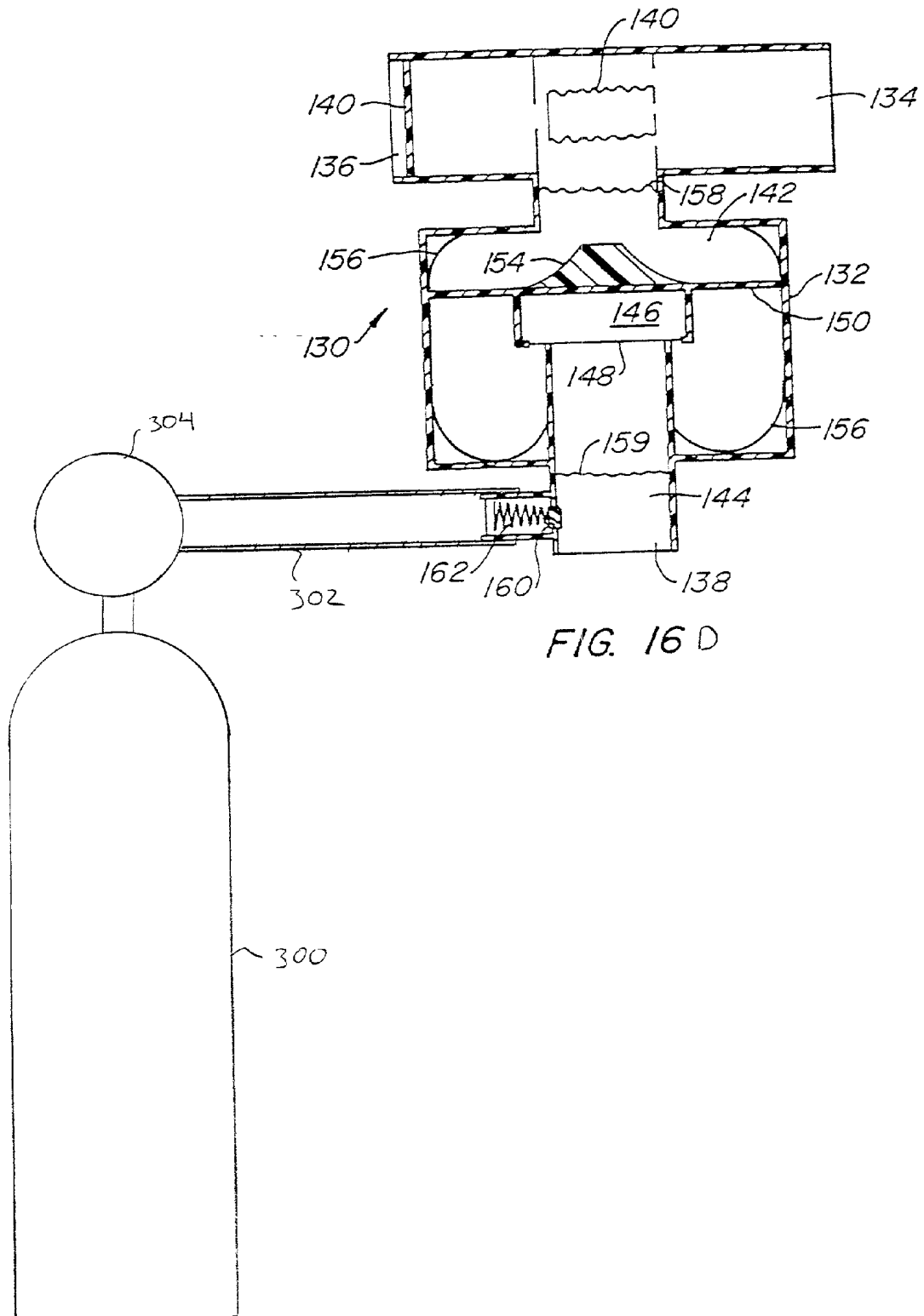

FIG. 16 D

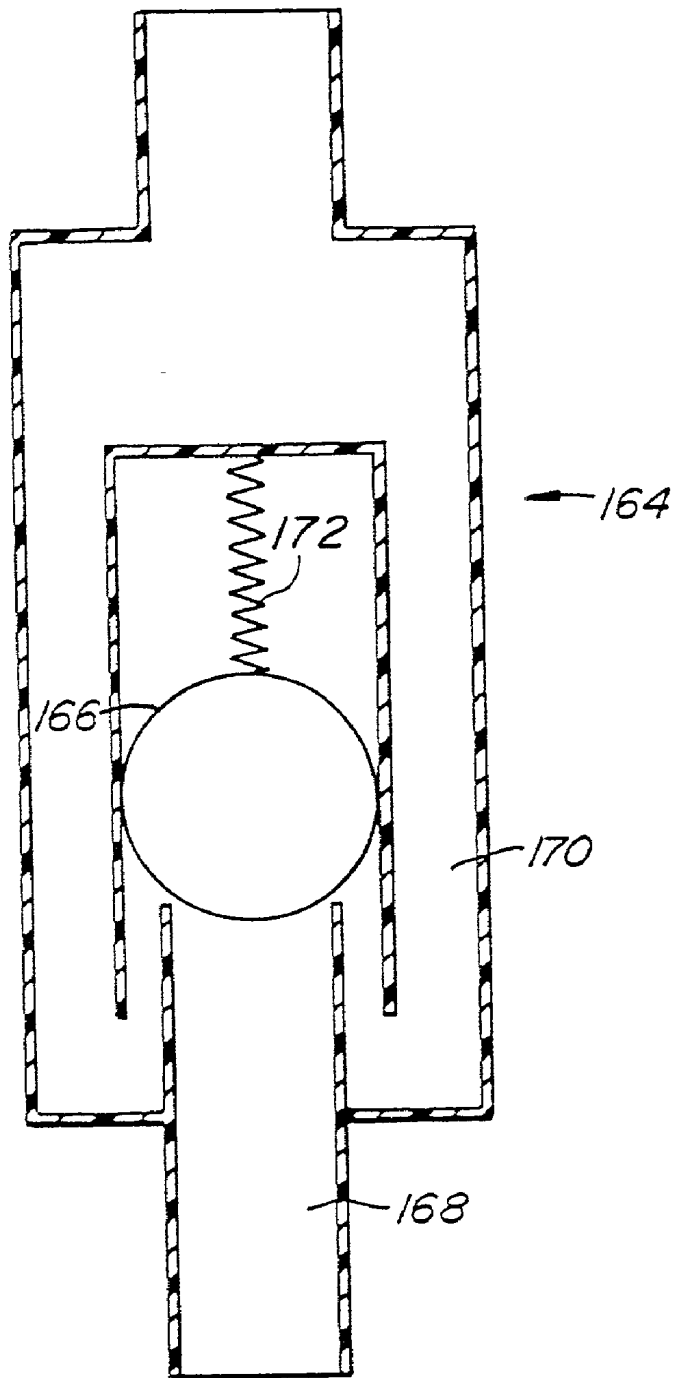

FIG. 17.

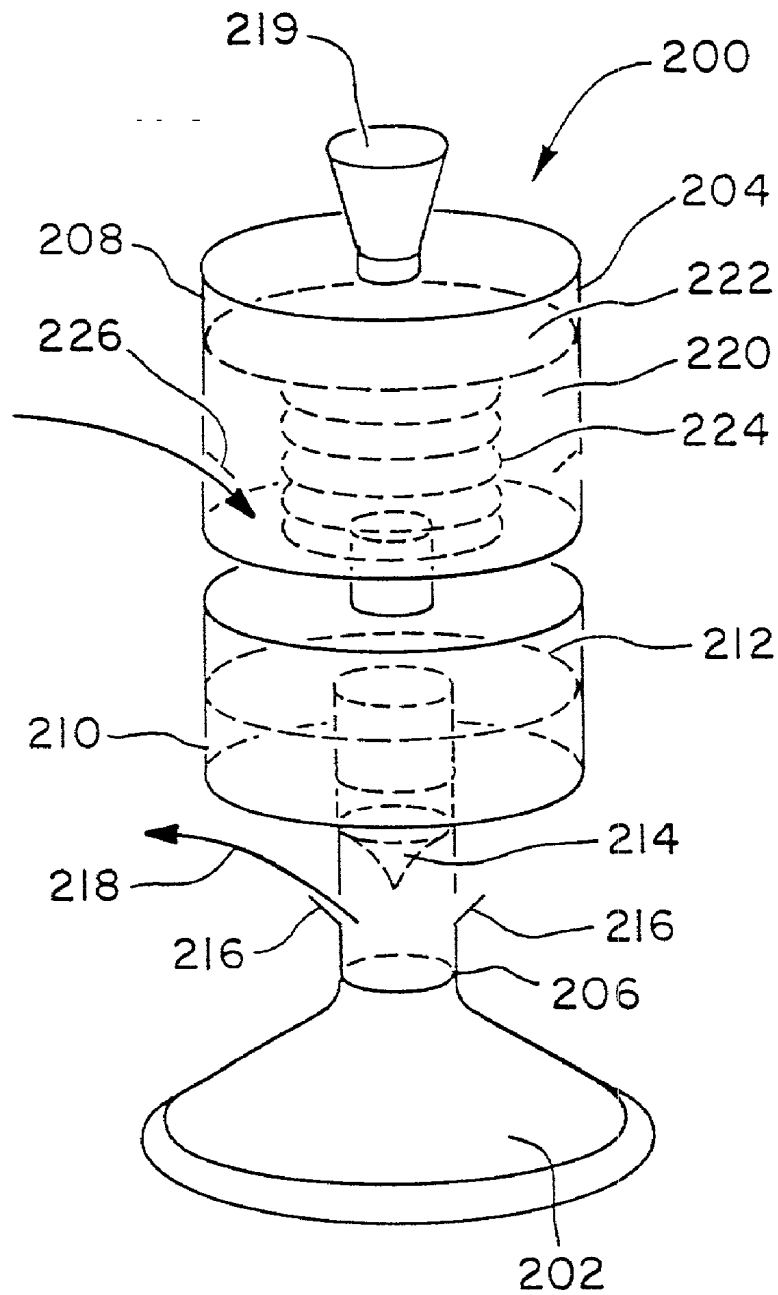

Fig. 18

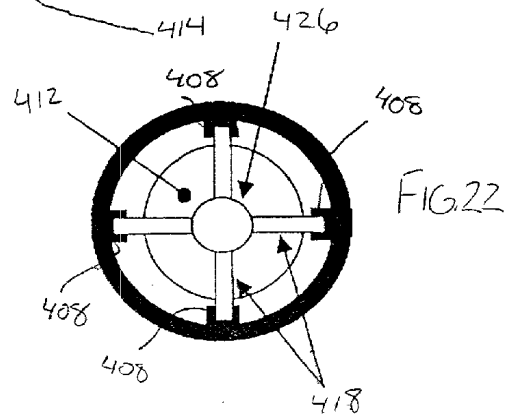
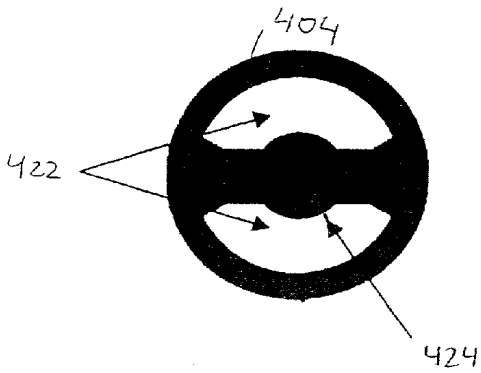
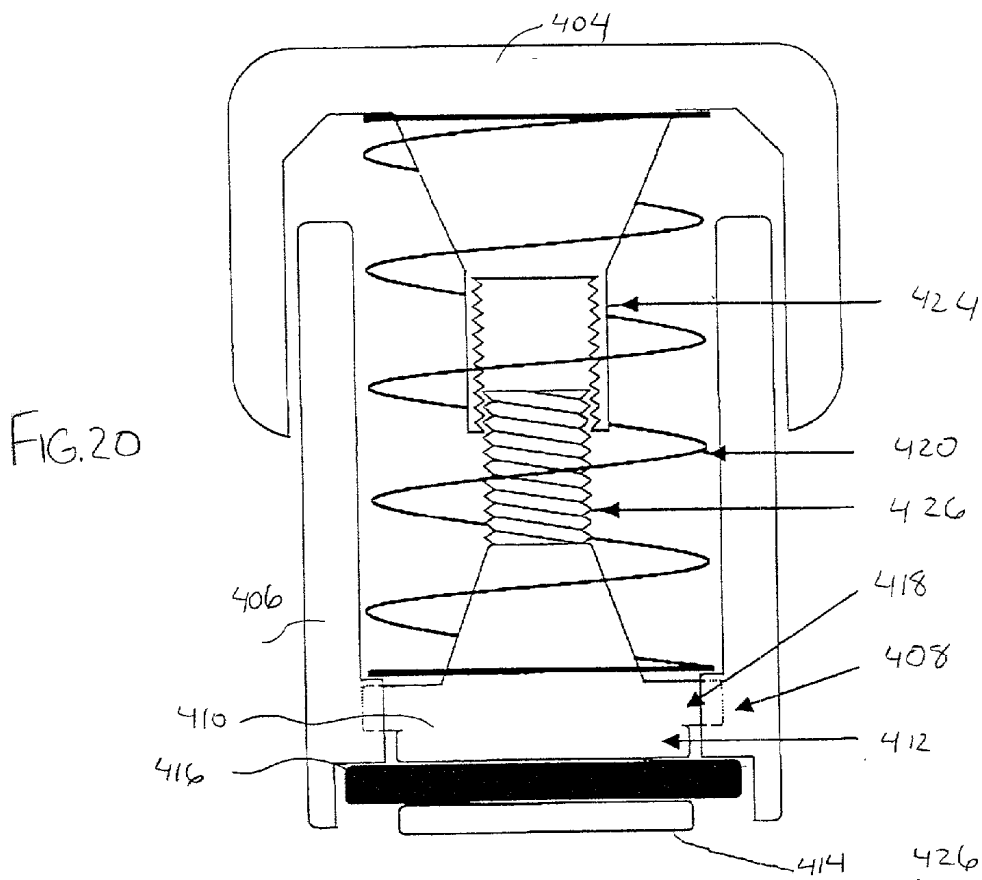
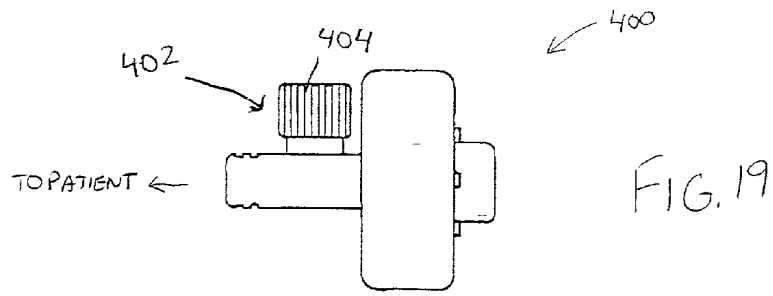

FIG.24

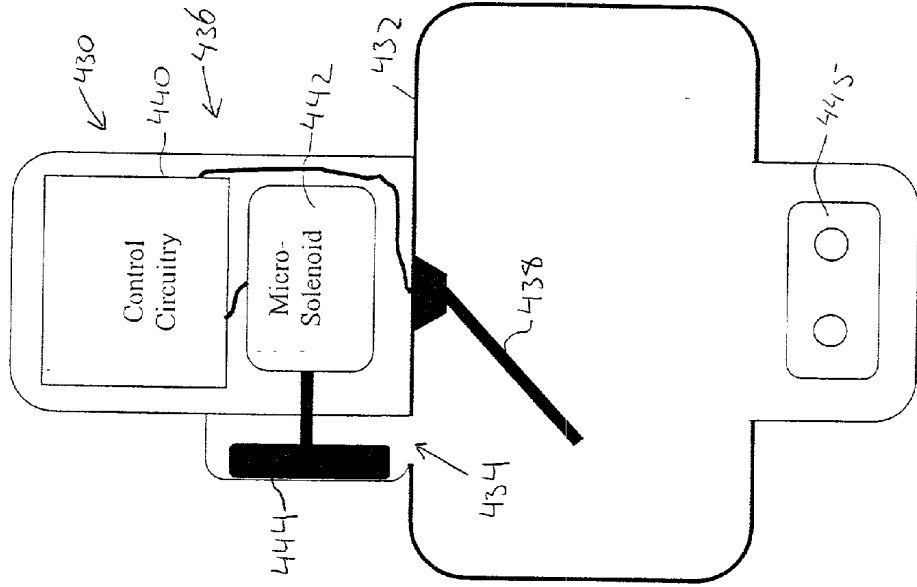
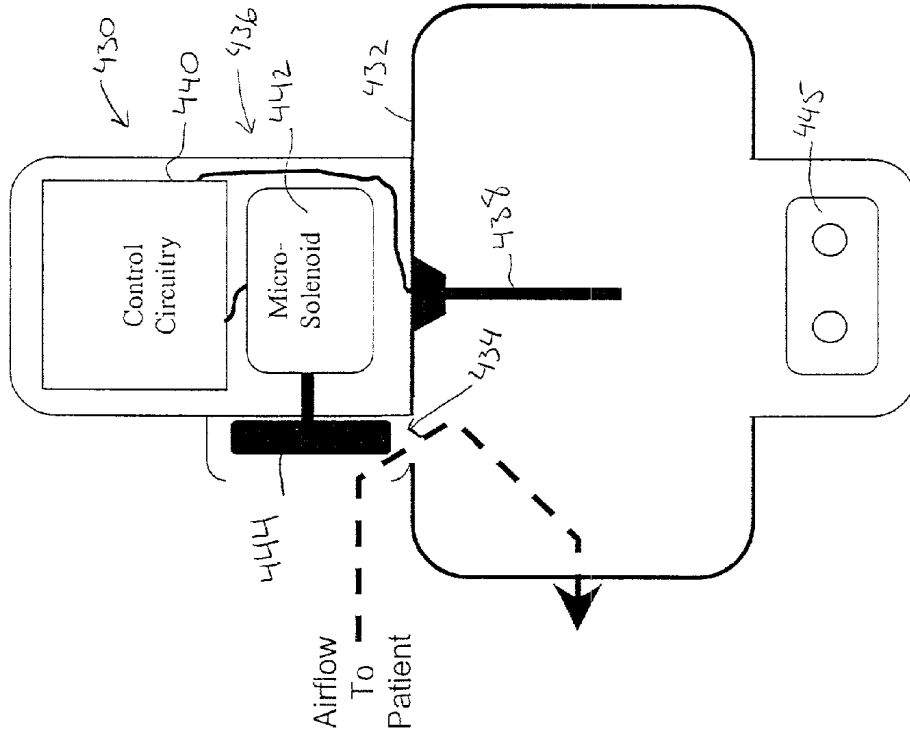

FIG.23



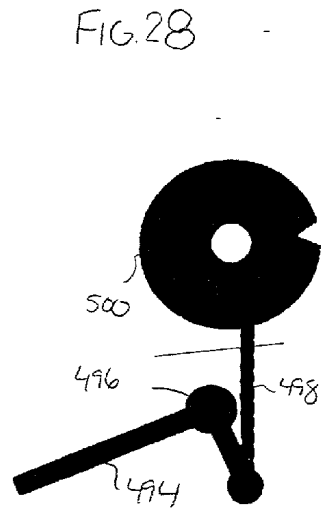
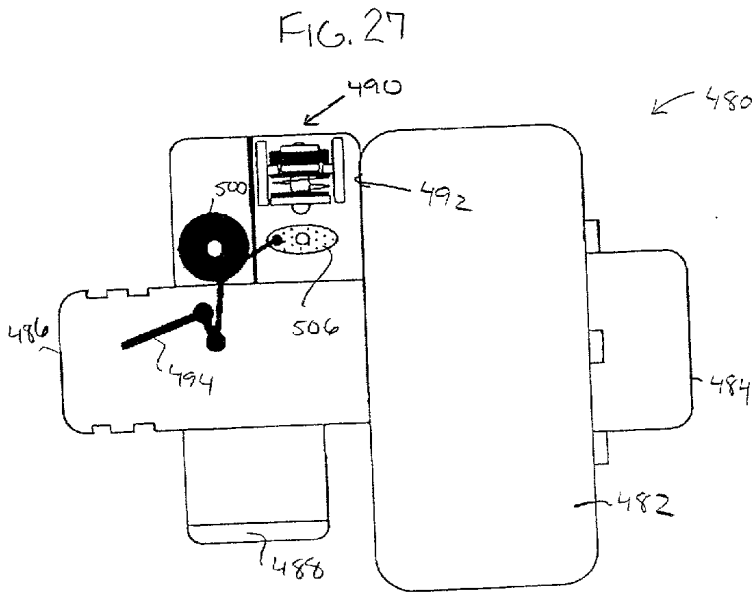
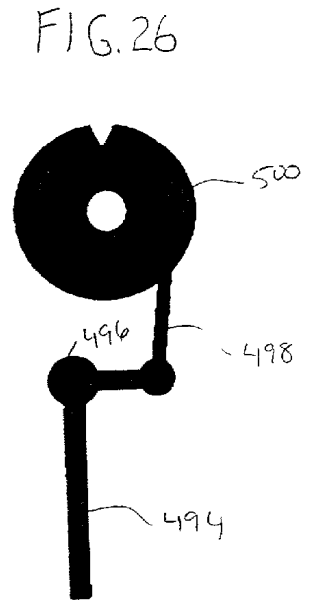
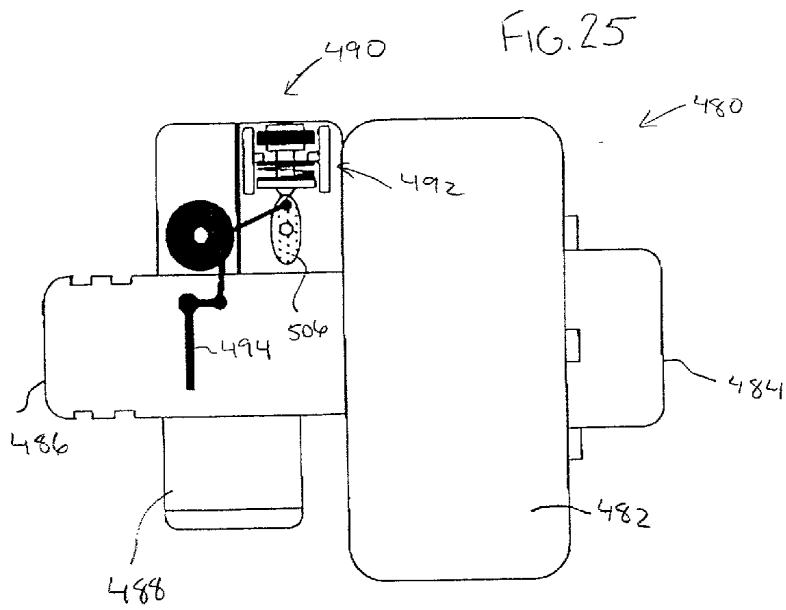
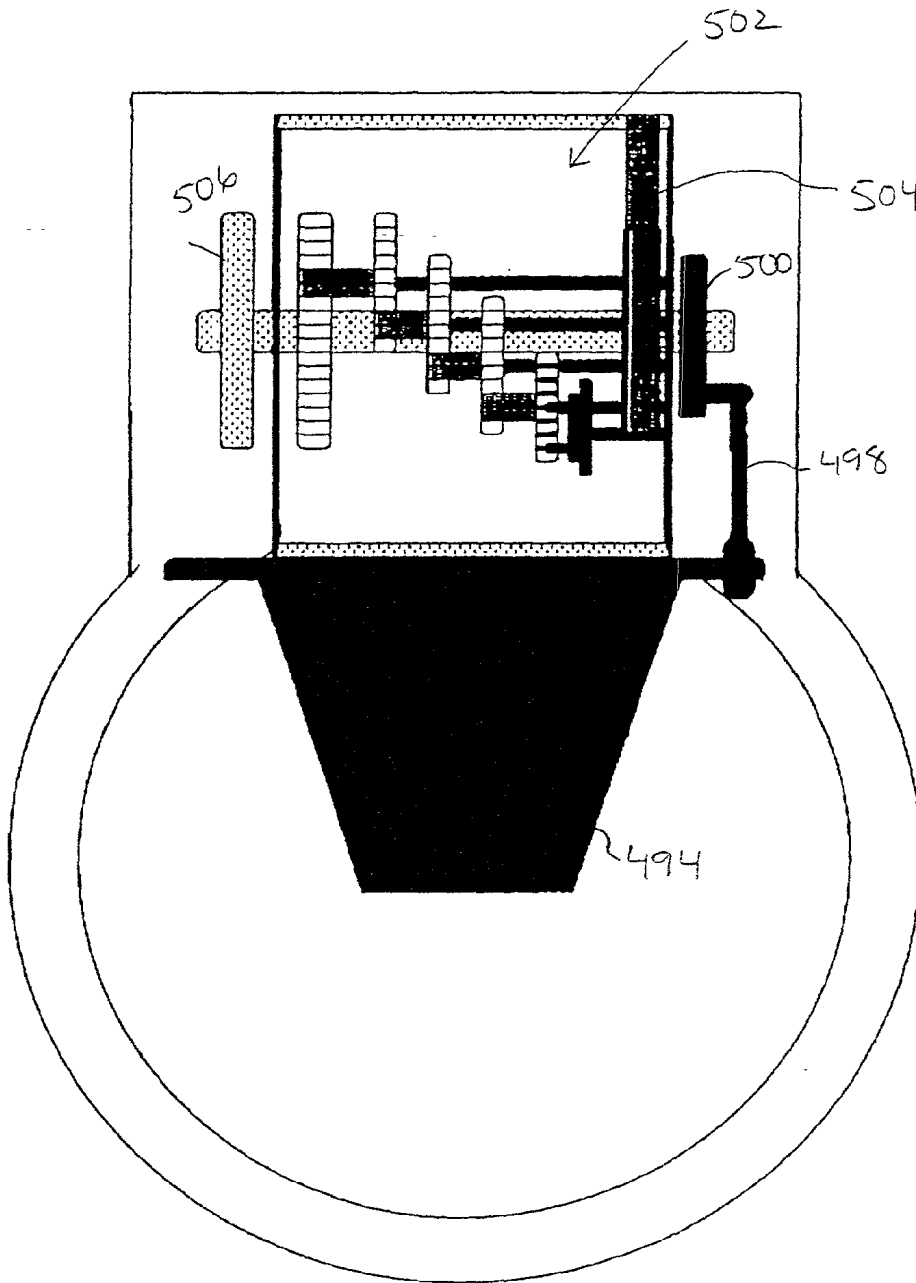

FIG. 29



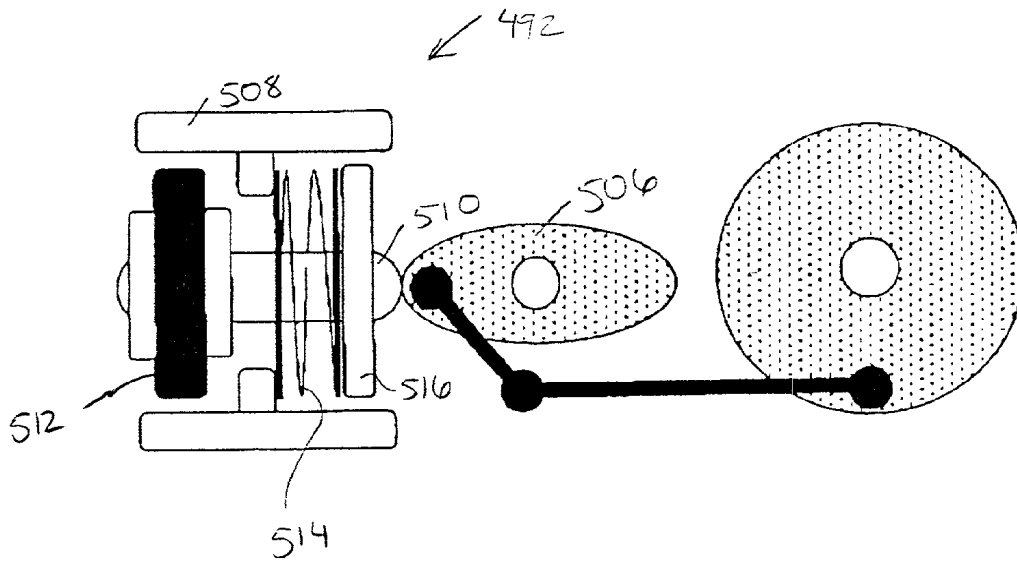

FIG. 30

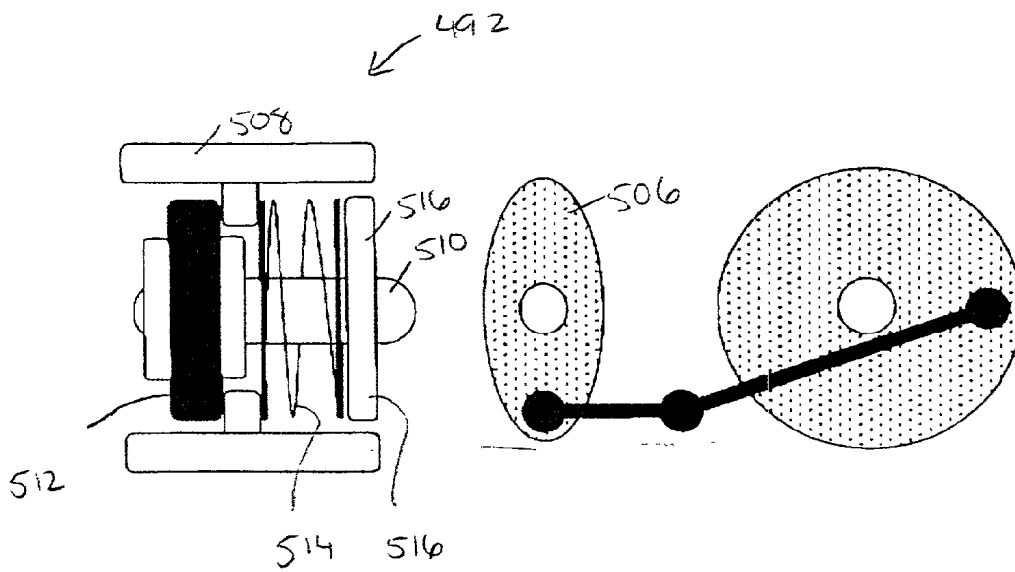

FIG. 31

FIG. 32

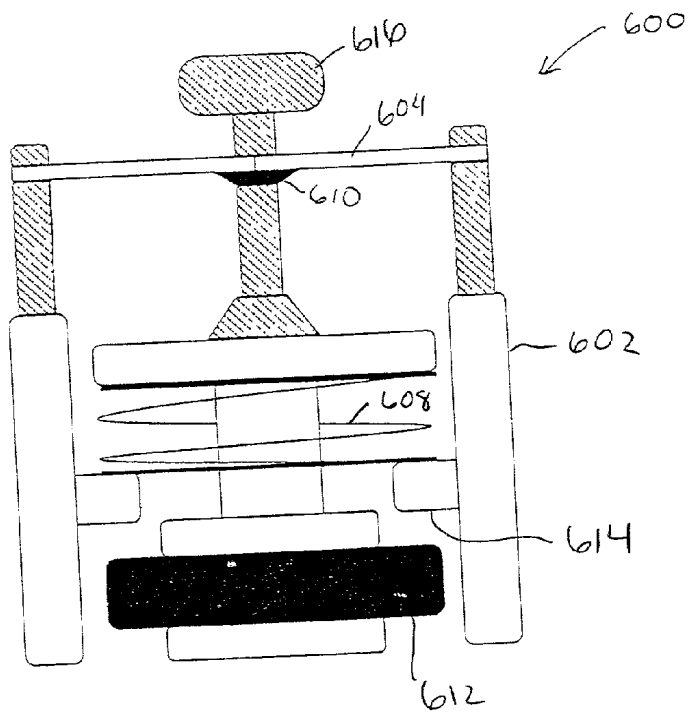
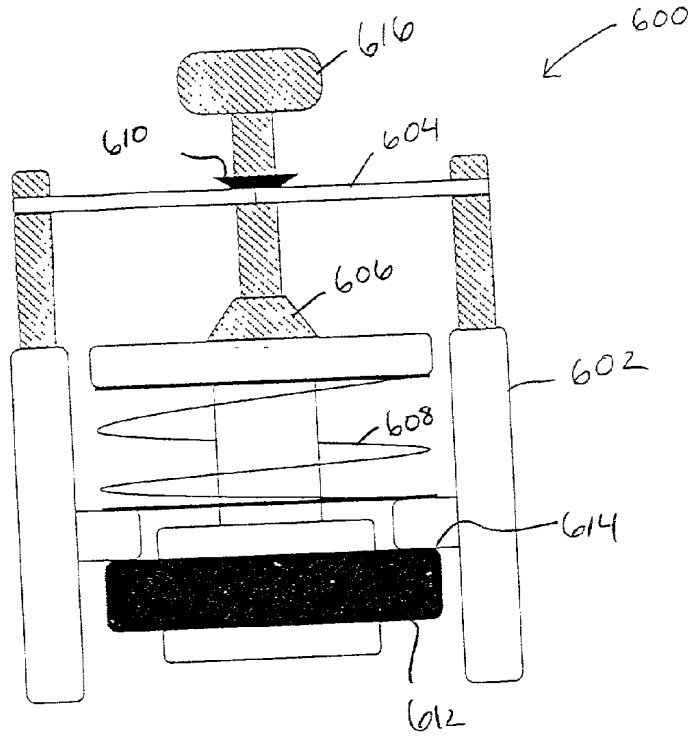

FIG. 33

FIG. 34

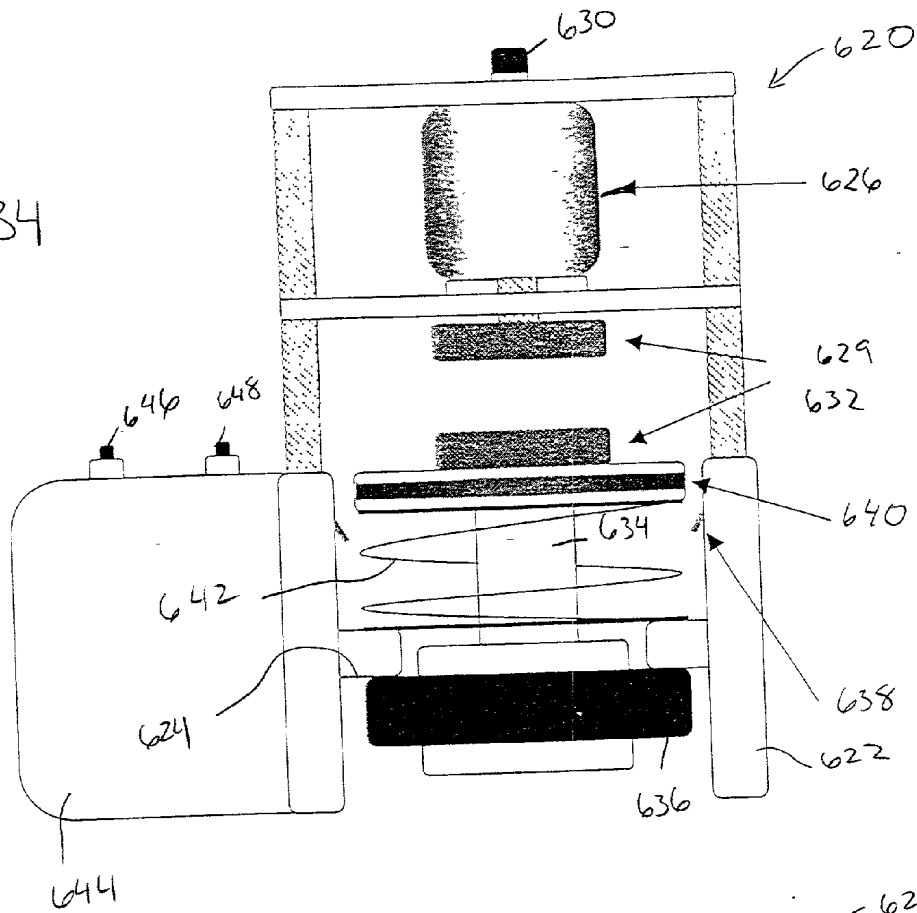

FIG. 35

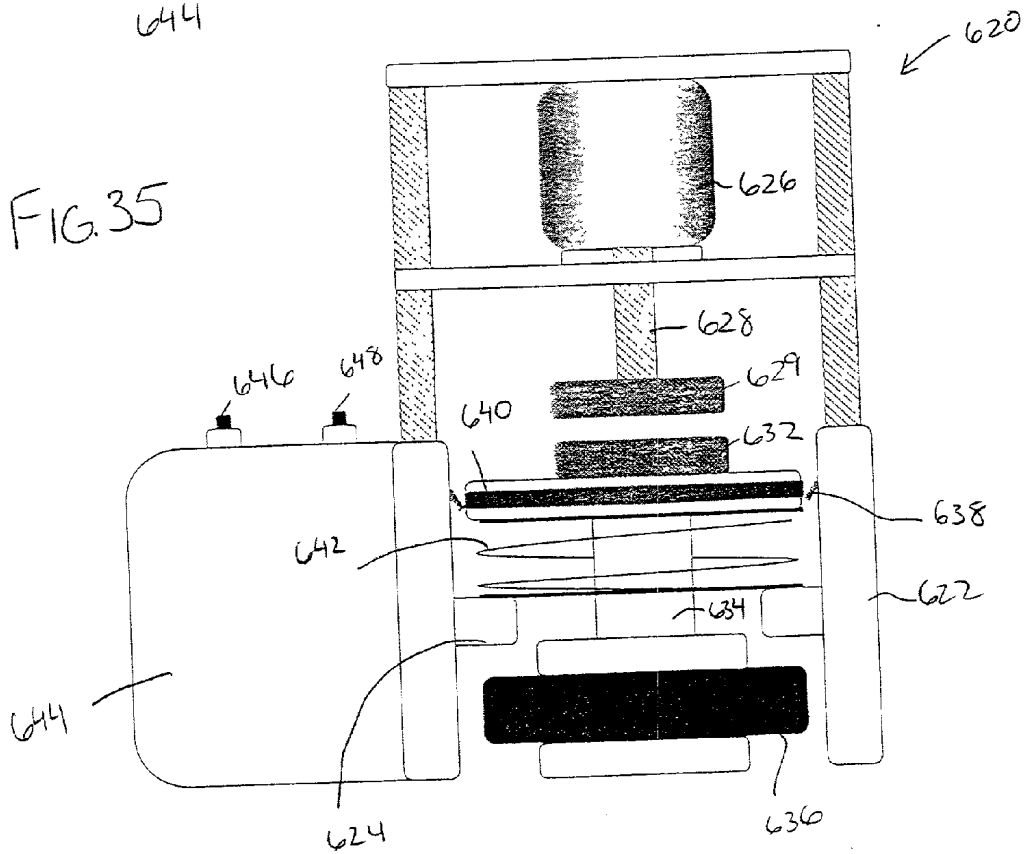

FIG. 36

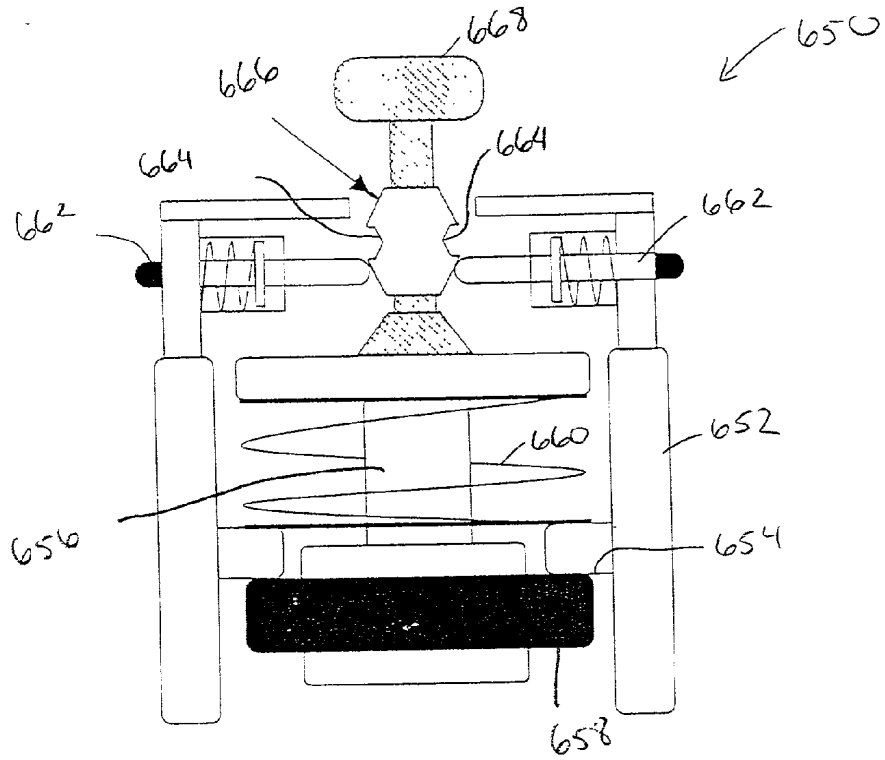
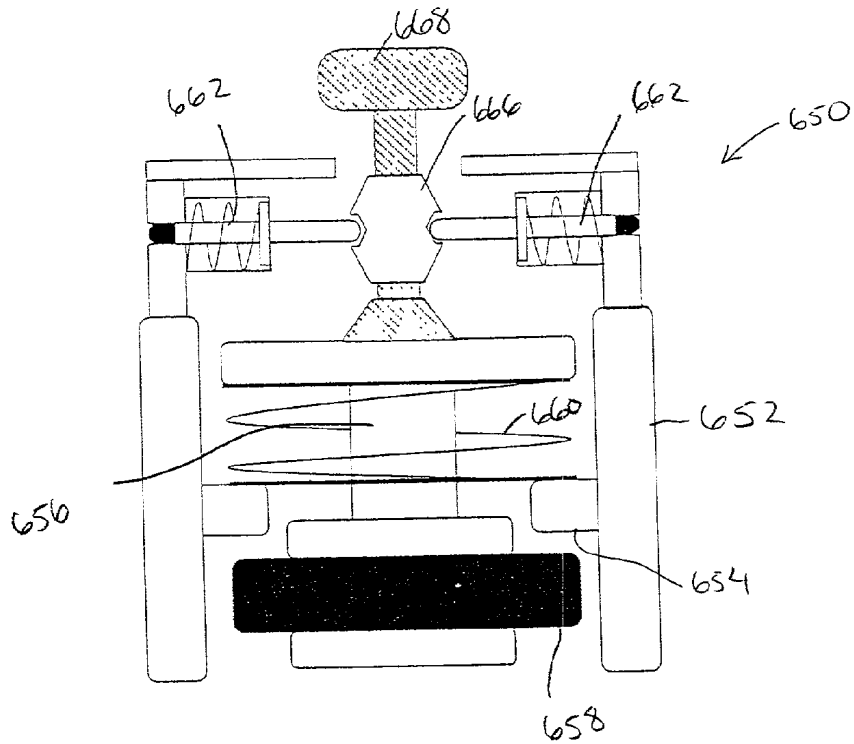

FIG. 37



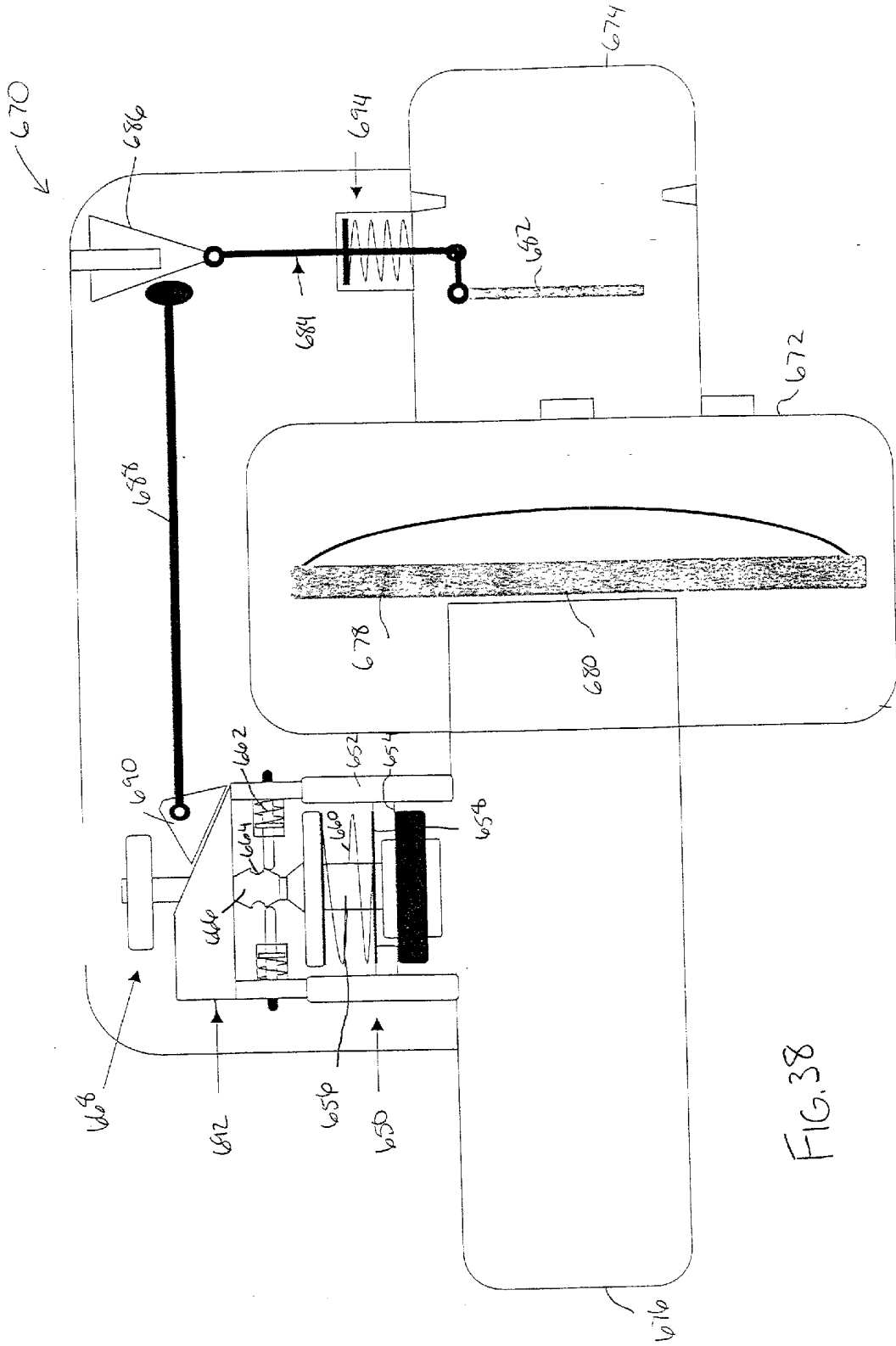

FIG. 38

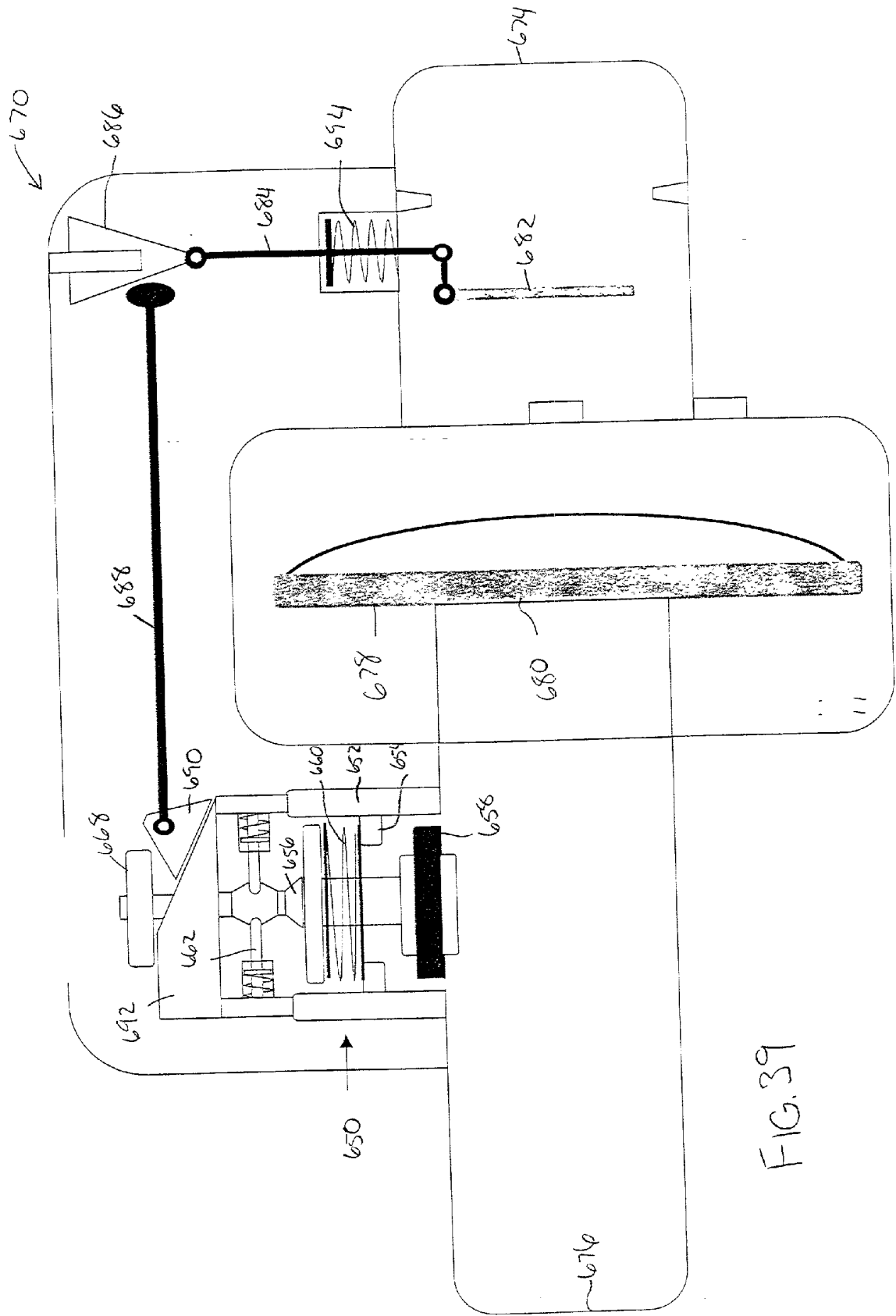
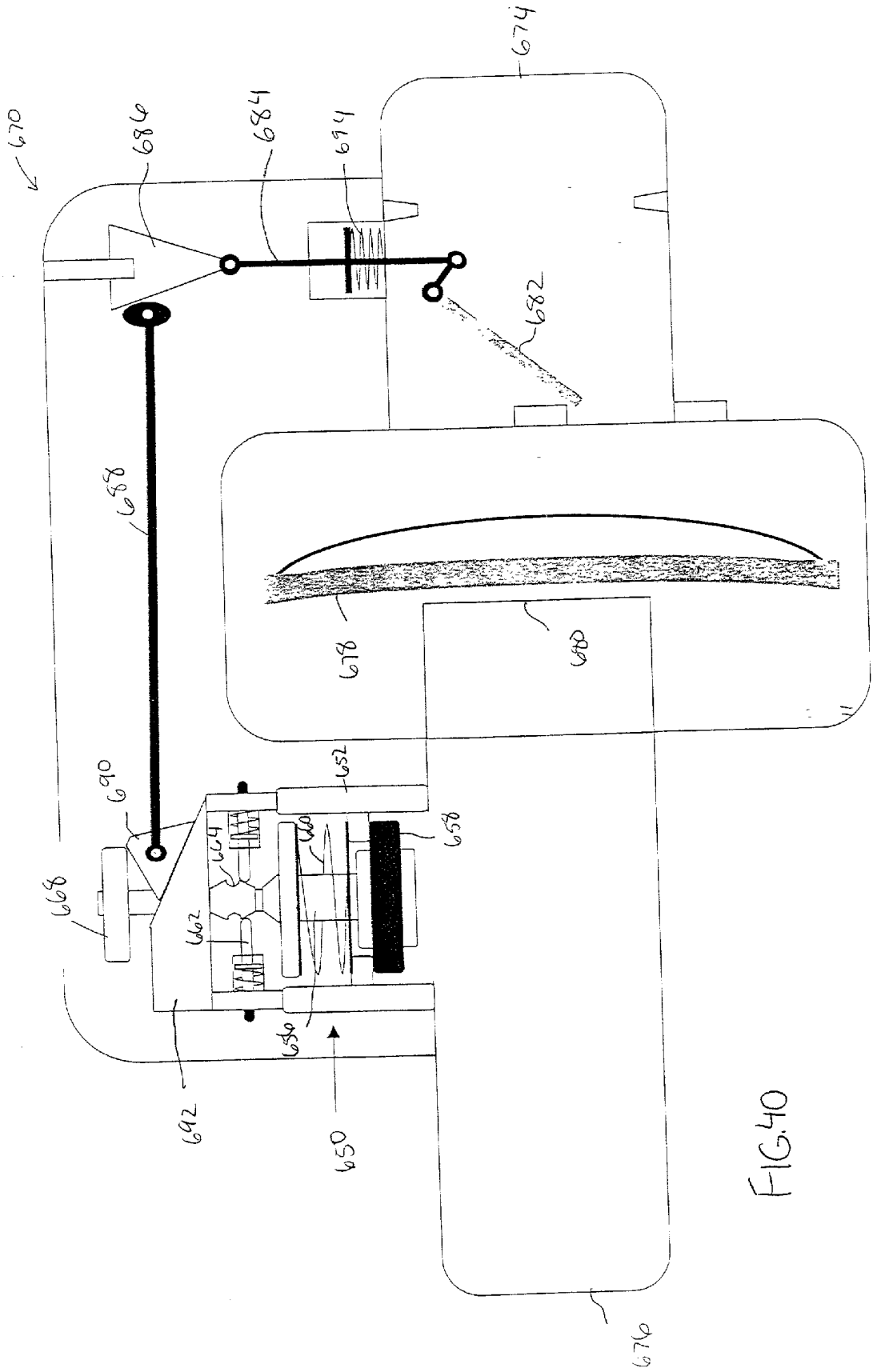

FIG. 39



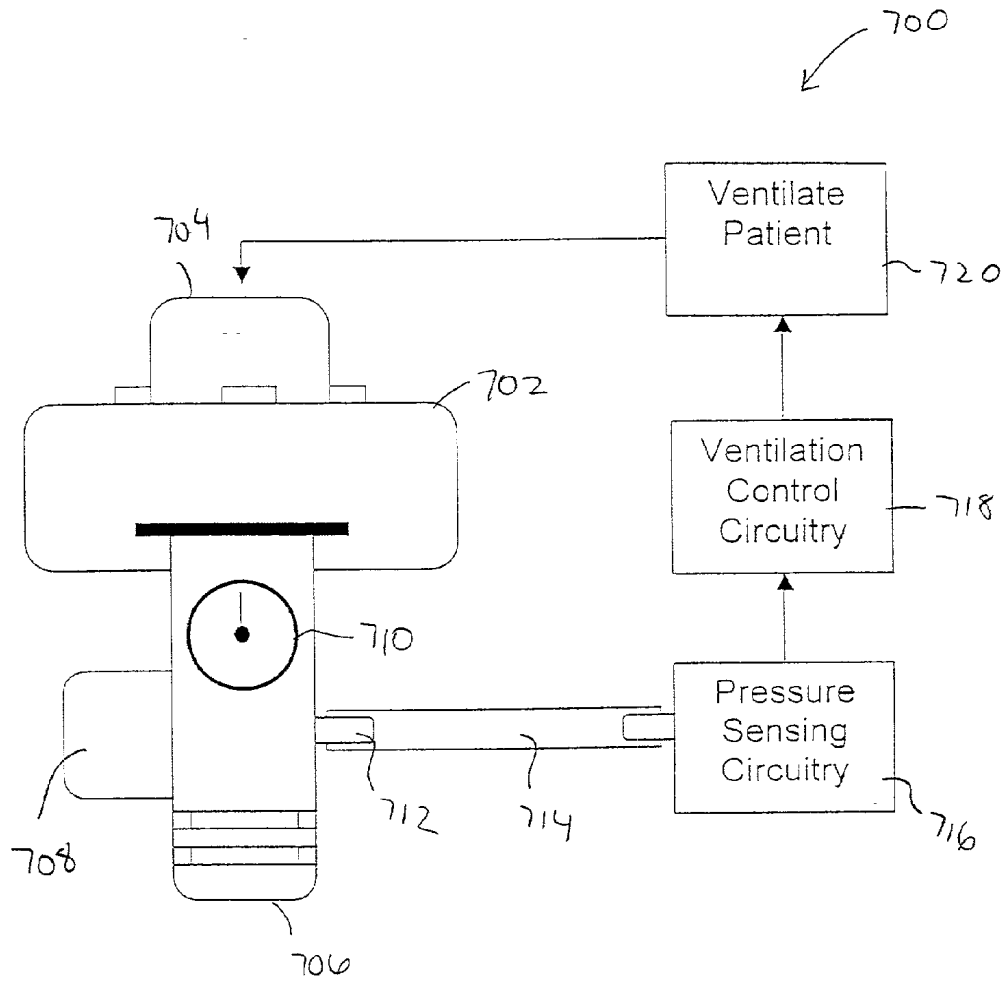

FIG. 41

APPARATUS AND METHODS FOR ENHANCING CARDIOPULMONARY BLOOD FLOW AND VENTILATION

CROSS-REFERENCES TO RELATED APPLICATIONS

[0001] This application is a continuation in part application of U.S. patent application Ser. No. 09/546,252, filed Apr. 10, 2000, which is a continuation of U.S. patent application Ser. No. 08/950,702, filed Oct. 15, 1997 (now U.S. Pat. No. 6,062,219), which is a continuation-in-part application of U.S. patent application Ser. No. 08/403,009, filed Mar. 10, 1995 (now U.S. Pat. No. 5,692,498), which is a continuation-in-part application of U.S. patent application Ser. No. 08/149,204, filed Nov. 9, 1993 (now U.S. Pat. No. 5,551,420), the disclosures of which are herein incorporated by reference.

BACKGROUND OF THE INVENTION

[0002] The present invention relates generally to devices and methods used in conjunction with cardiopulmonary resuscitation procedures. In particular, the present invention relates to devices and methods for increasing cardiopulmonary circulation in patients with severe low blood pressure or cardiac arrest.

[0003] Worldwide, sudden cardiac arrest is a major cause of death and is the result of a variety of circumstances, including heart disease and significant trauma. In the event of a cardiac arrest, several measures have been deemed to be essential in order to improve a patient's chance of survival. These measures must be taken as soon as possible to at least partially restore the patient's respiration and blood circulation. One common technique, developed approximately 40 years ago, is an external chest compression technique generally referred to as cardiopulmonary resuscitation (CPR). CPR techniques have remained largely unchanged over the past three decades.

[0004] With traditional CPR, pressure is applied to a patient's chest in order to increase intrathoracic pressure. An increase in intrathoracic pressure induces blood movement from the region of the heart and lungs towards the peripheral arteries. Such pressure partially restores the patient's circulation. Traditional CPR is performed by actively compressing the chest by direct application of an external pressure to the chest. After active compression, the chest is allowed to expand by its natural elasticity which causes expansion of the patient's chest wall. This expansion allows some blood to enter the cardiac chambers of the heart. The procedure as described, however, is insufficient to ventilate the patient. Consequently, conventional CPR also requires periodic ventilation of the patient. This is commonly accomplished by mouth-to-mouth technique or by using positive-pressure devices, such as a self-inflating bag which relies on squeezing an elastic bag to deliver air via a mask, endotracheal tube or other artificial airway.

[0005] In order to increase cardiopulmonary circulation induced by chest compression, a technique referred to as active compression-decompression (ACD) has been developed. According to ACD techniques, the active compression phase of traditional CPR is enhanced by pressing an applicator body against the patient's chest to compress the chest. Such an applicator body is able to distribute and apply force

substantially evenly over a portion of the patient's chest. More importantly, however, the applicator body is sealed against the patient's chest so that it may be lifted to actively expand the patient's chest during the decompression step. The resultant negative intrathoracic pressure induces venous blood to flow into the heart and lungs from the peripheral venous vasculature of the patient.

[0006] Also of importance to the invention are ventilation sources that are used in connection with CPR techniques to properly ventilate the patient. One type of ventilation source is the AMBU bag available from AMBU International, Copenhagen, Denmark. The AMBU bag can also be used in connection with a positive end-expiratory pressure (PEEP) valve, available from AMBU International, to treat some patients with pulmonary and cardiac diseases. However, until the present invention, a positive end-expiratory pressure valve in connection with a ventilation source has not been used with any CPR techniques.

[0007] With both traditional CPR and ACD-CPR techniques, an increase in the amount of venous blood flowing into the heart and lungs from the peripheral venous vasculature would be desirable to increase the volume of oxygenated blood leaving the thorax during the subsequent compression phase. It would therefore be desirable to provide improved methods and apparatus for enhancing venous blood flow into the heart and lungs of a patient from the peripheral venous vasculature during both conventional CPR and ACD-CPR techniques. It would be particularly desirable to provide techniques which would enhance oxygenation and increase the total blood return to the chest during the decompression step of CPR and ACD-CPR, more particularly of ACD-CPR. This can be accomplished according to the present invention by augmentation of both negative and positive intrathoracic pressure, thereby amplifying the total intrathoracic pressure swing. An invention for providing this crucial improvement is described.

[0008] Severe hypotension or very low blood pressure can lead to passing out and in some circumstances cardiac arrest. Like cardiac arrest, patients with low blood pressure often suffer from insufficient blood returning to the heart after each beat. This results in a decrease in forward blood flow out of the heart and eventually to low blood pressure. It would therefore be desirable to provide techniques or devices that would increase venous blood flow to the heart when a person suffers from low blood pressure. According to the invention, such an approach could help return blood flow to the heart and result in an increase in blood flow to the vital organs.

[0009] ACD-CPR techniques are described in detail in Todd J. Cohen et al., *Active Compression-Decompression Resuscitation: A Novel Method of Cardiopulmonary Resuscitation*, American Heart Journal, Vol. 124, No. 5, pp. 1145-1150, November 1992; and Todd J. Cohen et al., *Active Compression-Decompression: A New Method of Cardiopulmonary Resuscitation*, The Journal of the American Medical Association, Vol. 267, No. 21, Jun. 3, 1992. These references are hereby incorporated by reference.

[0010] The use of a vacuum-type cup for actively compressing and decompressing a patient's chest during ACD-CPR is described in a brochure of AMBU International A/S, Copenhagen, Denmark, entitled Directions for Use of AMBU® Cardiopump™, published in September 1992. The

AMBU® Cardiopump™ is also disclosed in European Patent Application No. 0 509 773 A1. These references are hereby incorporated by reference.

SUMMARY OF THE INVENTION

[0011] According to the invention, methods and devices for increasing cardiopulmonary circulation are provided. The methods and devices may be used in connection with any generally accepted CPR methods or with active compression decompression (ACD) CPR techniques. Preferably, the methods and devices will be used in connection with ACD-CPR. In one aspect, they may be used in patients with severe low blood pressure and who are not in cardiac arrest and breathe spontaneously.

[0012] Cardiopulmonary circulation is increased according to the invention by impeding airflow into a patient's lungs during the CPR decompression phase or during a spontaneous inhalation. This increases the magnitude and prolongs the duration of negative intrathoracic pressure during in the patient's chest, i.e., increases the duration and degree that the intrathoracic pressure is below or negative with respect to the pressure in the peripheral venous vasculature. By enhancing the amount of venous blood flow into the heart and lungs, since equilibration of intrathoracic pressure during decompression occurs to a greater extent from enhanced venous return rather than rapid inflow of gases into the chest via the patient's airway, cardiopulmonary circulation is increased.

[0013] In a specific embodiment, impeding the airflow into the patient's lungs is accomplished by decreasing or preventing ventilation during the decompression phase of CPR. The method employs the use of a flow restrictive or limiting member, such as a flow restrictive orifice disposed within or connected in series with a lumen of a ventilation tube, or a pressure-responsive valve within a lumen of the tube to impede the inflow of air. The pressure-responsive valve is biased to open to permit the inflow of air when the intrathoracic pressure falls below a threshold level. In order to properly ventilate the patient, the method preferably provides for periodically ventilating the patient through the ventilation tube after compression of the patient's chest. When periodic ventilation is performed, gases can be delivered either through the impeding step or in another embodiment they can bypass the impeding step. In some cases, an oxygen enriched gas may be supplied to the patient through the pressure-responsive valve once this valve opens.

[0014] An exemplary embodiment provides for covering the patient's mouth and nose with a facial mask. This mask contains means for impeding airflow into the patient's airway during decompression of the patient's chest, e.g. either an orifice or valve as just discussed.

[0015] A specific embodiment further provides means for impeding air from leaving the lungs during compression of the patient's chest to further enhance cardiopulmonary circulation by enhancing positive intrathoracic pressure during the compression phase.

[0016] When performing cardiopulmonary resuscitation to enhance circulation according to the invention, an operator compresses a patient's chest to force blood out of the patient's thorax. The patient's chest is then decompressed to induce venous blood to flow into the heart and lungs from

the peripheral venous vasculature either by actively lifting the chest (via ACD-CPR) or by permitting the chest to expand due to its own elasticity (via conventional CPR). During the decompression step, airflow is impeded from entering into the patient's lungs which enhances negative intrathoracic pressure and increases the time during which the thorax is at a lower pressure than the peripheral venous vasculature. Thus, venous blood flow into the heart and lungs from the peripheral venous vasculature is enhanced. This is because the intrathoracic pressure equilibrium during decompression occurs as a result of enhanced venous return rather than from inflow of air via the trachea. In a particular embodiment, compression and decompression of the patient's chest may be accomplished by pressing an applicator body against the patient's chest to compress the chest, and lifting the applicator to actively expand the patient's chest.

[0017] An apparatus for enhancing cardiopulmonary circulation according to the method comprises an improved endotracheal tube having a flow restrictive element for impeding airflow from the patient's lungs during chest decompression. A second apparatus according to the invention provides for an improved air-delivery system comprising a compressible structure having a flow restrictive element included in or attached to an opening of the compressible structure to impede the flow of gases to the patient's lungs. Also, a connector is provided for interfacing the compressible structure to the patient, preferably by attaching a facial mask or endotracheal tube to the structure.

[0018] In another aspect of the invention, a valving system is provided for regulating airflow into a patient's lungs when performing cardiopulmonary resuscitation. The system includes a housing having an upstream region and a downstream region. A means is provided between the upstream region and the downstream region for inhibiting air from flowing from the upstream region to the downstream region when the pressure in the downstream region is less than the pressure in the upstream region. In this manner, air is inhibited from flowing into the patient's lungs during decompression of the patient's chest thereby forcing more venous blood into the chest and enhancing vital organ perfusion. A means is further provided for allowing air to flow into the downstream region when ventilating the patient. In this way, adequate ventilation can be provided to the patient during the procedure.

[0019] In one particular aspect, the inhibiting means comprises a valve which inhibits airflow from the upstream region to the downstream region when the pressure in the downstream region is less than the pressure in the upstream region. The valve preferably includes a diaphragm which is closed when the pressure in the downstream region is less than or equal to the pressure in the upstream region. Such a configuration prevents air from flowing into the patient's lungs during decompression of the patient's chest while allowing air to be exhausted from the patient's lungs during compression. Preferably, the diaphragm is constructed of a flexible membrane. Alternatively, the diaphragm can be constructed using a ball.

[0020] In another particular aspect, the diaphragm is biased to open when the pressure in the downstream region is about 2 cm H₂O or greater, and more preferably at about 2 cm H₂O to 10 cm H₂O. Biasing of the diaphragm in this

manner increases intrathoracic pressure during compression of the patient's chest to further enhance vital organ perfusion.

[0021] In still a further aspect, the means for allowing air into the downstream region includes a means for opening the diaphragm when air is injected into the upstream region to ventilate the patient. The means for opening the diaphragm preferably includes an ambient pressure region that is adjacent the diaphragm. When air is injected into the upstream region, the pressure within the upstream region increases thereby drawing the diaphragm into the ambient pressure region and allowing the air to flow to the patient's lungs.

[0022] In yet another aspect, the means for allowing air into the downstream region includes a manually operable valve at the downstream region which is manually opened to allow air to flow into the downstream region upon return of spontaneous circulation. In this manner, a rescuer can manually open the valve when the patient begins breathing.

[0023] In an alternative aspect, the means for allowing air into the downstream region comprises a pressure-responsive valve at the downstream region. The pressure-responsive valve allows air into the downstream region when the pressure in the downstream region falls below a threshold level, usually in the range from -3 cm H_2O to -30 cm H_2O . The pressure responsive valve is advantageous in allowing ventilation to be provided to the patient while still employing the diaphragm to enhance the extent and duration of negative intrathoracic pressure. Examples of pressure-responsive valves that may be used include, for example, a spring biased valve, an electromagnetically driven valve, or a valve constructed of any deflectable material that will deflect when the threshold pressure is exceeded. As one specific example, the valve may be constructed of a magnetically charged piece of material with a narrow tolerance that is attracted to a gate. This valve will open when the magnetically charged gate pressure is exceeded. In this way, when the negative intrathoracic pressure is exceeded, the valve will be pulled away from the gate to permit gases to flow to the lungs. Such a valve could also be used in place of the diaphragm valve discussed above.

[0024] In one option, a source of oxygen-enriched gas may be coupled to the pressure-responsive valve to supply an oxygen-enriched gas to the patient when the pressure responsive valve is opened. A regulator may be employed to regulate the pressure and/or flow rate of the gas. For example, the pressure may be regulated to be less than the actuating pressure of the valve so that the pressurized gas will not flow to the patient's lungs until the valve is opened when the negative intrathoracic pressure is exceeded.

[0025] The system of the invention in another aspect is provided with an air exhaust opening in the housing at the upstream region for exhausting air from the housing. A valve is provided in the exhaust opening which inhibits air from flowing into the housing through the exhaust opening. In this manner, air exhausted from the patient is in turn exhausted from the housing through the exhaust opening. In a further aspect, means are provided for preventing air from exiting the housing through the exhaust opening during injection of air into the housing when ventilating the patient. Preferably air is injected into the housing from a respiratory device, such as a respiratory bag, a ventilator, or the like, or by mouth-to-mouth breathing through a port or a mouthpiece.

[0026] In still a further aspect of the invention, an endotracheal tube, a sealed facial mask, a laryngeal mask, or other airway tube, or the like is provided and is connected to the housing at the downstream region for attachment to the patient. The endotracheal tube or like device is for insertion into the patient's airway and provides a convenient attachment for the valving system to the patient.

[0027] The invention further provides an exemplary device for increasing cardiopulmonary circulation that is induced by chest compression and decompression when performing cardiopulmonary resuscitation. The device comprises a facial mask and a housing that is operably attached to the mask. The housing includes a mouth piece and at least one inflow valve which prevents respiratory gases from entering the lungs until a threshold negative intrathoracic pressure level is exceeded at which time the inflow valve opens. The housing further includes an air chamber in communication with the mouth piece, and a valve member to force air from the air chamber and into the facial mask when air is supplied through the mouth piece. In this way, a rescuer may blow into the mouth piece to periodically ventilate the patient with air or oxygen-enriched gas stored in the chamber, rather than introducing respiratory gases from the rescuer's lungs.

[0028] In a similar vein, the invention provides an exemplary method for increasing cardiopulmonary circulation that is induced by chest compression and decompression when performing cardiopulmonary resuscitation. According to the method, at least one inflow valve and an air chamber are interfaced to a patient's airway. Chest compression and chest decompression is then performed, with the inflow valve preventing respiratory gases from entering the lungs during decompression until a threshold negative intrathoracic pressure is exceeded. Air is periodically transferred from the air chamber into the patient's lungs so as to properly ventilate the patient with air. In one exemplary aspect, the air is transferred from the air chamber to the patient's lungs by manually blowing into the chamber. In this way, the rescuer may blow into the chamber to transfer air to the patient's lungs without introducing respiratory gases from the rescuer's lungs.

[0029] In one embodiment, the invention provides a mechanism to vary the actuating pressure of the inflow valve. In this way, the rescuer is able to operate the mechanism to vary the impedance depending upon the condition of the patient. In some cases, the valve systems of the invention may include a pressure gauge to display the intrathoracic pressures. By having this information readily available, the rescuer has more information to assist in setting the desired actuating pressure of the inflow valve.

[0030] In one aspect, the varying mechanism is configured to vary the actuating pressure to a pressure within the range from about 0 cm H_2O to about -30 cm H_2O . In another aspect, the inflow valve comprises a shaft having a seal that is configured to block an opening in the housing, and a spring that biases the seal against the housing. With such a configuration, the mechanism may comprise a knob that is movable to vary the biasing force of the spring. For example, the knob may be rotatably coupled to the shaft so that the rescuer may simply turn the knob to vary the actuating pressure.

[0031] In another embodiment, the valve systems of the invention may be provided with a safety ventilation passage.

If the valve system is inappropriately applied to a patient who is spontaneously breathing, the patient may breath through this passage while the valve system is coupled to the patient's airway. A safety mechanism is used to maintain the safety ventilation passageway open to permit respiratory gases to freely flow to the patient's lungs until actuated by a rescuer to close the safety ventilation passageway. With such an arrangement, the patient is able to freely breathe if they are capable of so doing. If the patient stops breathing on their own, the rescuer may set the valve system so that the ventilation passage is closed and the inflow valve provides the desired resistance during CPR. In this way, respiratory gases are permitted only once the cracking pressure of the threshold valve is exceeded, or when the patient is actively ventilated. As with other embodiments, the cracking pressure may be exceeded by decompressing the patient's chest during CPR, by the patient's own inhalation, or the like.

[0032] In one aspect, the safety ventilation passageway is provided through the inflow valve when the inflow valve is in an open position. With this configuration, the safety mechanism is configured to maintain the inflow valve in the open position until actuated by the rescuer to move the inflow valve to a closed position. A variety of ways may be used to actuate the safety mechanism. For example, the housing may include a ventilation port to permit respiratory gases to be injected into the housing, and the safety mechanism may comprise a sensor to sense when the rescuer injects respiratory gases into the housing. In one embodiment, a signal from the sensor is used by a control system to move the inflow valve from the open position to the closed position. As an example, the sensor may be movable upon injection of respiratory gases into the housing, and the control system may comprise a set of gears that are coupled to the sensor and a cam that is movable by the gears to close the inflow valve. Alternatively, the control system may comprise an electronic controller, a solenoid and a cam. This mechanism may be configured to take electrical signals from the sensor and to operate the solenoid to move the cam and thereby close the inflow valve. As another example, a flap may be moved upon injection of the gases. The flap may cause the movement of a variety of mechanical components that physically reset the inflow valve to the closed position.

[0033] A variety of sensors may be used to sense injection of the respiratory gases. For example, sensors that may be used include electronic switches that move in a gas stream, thermistors to sense temperature changes, CO₂ detectors, materials that experience a change of resistance when flexed, mechanical flaps that move in a gas stream, and the like.

[0034] The invention also provides methods for increasing the blood pressure in a spontaneously breathing person. According to the method, a pressure responsive inflow valve is coupled to the person's airway and the person inhales and exhales. During inhalation, the inflow valve prevents respiratory gases from entering the lungs until a negative intrathoracic pressure level in the range from about 0 cm H₂O to -20 cm H₂O is exceeded at which time the inflow valve opens. In this way, the inflow valve assists in increasing blood flow back to the right heart of the person and thereby enhances the person's blood pressure. Such a process may be used to treat a variety of conditions where the person's blood pressure is low. For example, such a procedure may be used where the person has low blood pressure

due to blood loss, due to the administration of a drug, due to a high gravitational state, due to vasodepressor syncope, or the like.

[0035] A further understanding of the nature and advantages of the invention will become apparent by reference to the remaining portions of the specification and drawings.

BRIEF DESCRIPTION OF THE DRAWINGS

[0036] FIG. 1 is a graph illustrating thoracic pressure changes over time when compressing and decompressing a patient's chest according to the present invention.

[0037] FIG. 2A is a schematic view illustrating airflow through a ventilation circuit when compressing a patient's chest according to the present invention.

[0038] FIG. 2B is a schematic view illustrating airflow through a ventilation circuit when decompressing a patient's chest according to the present invention.

[0039] FIG. 3 is a schematic illustration of a first alternative embodiment of a device for impeding airflow into a patient's lungs according to the present invention.

[0040] FIG. 4A is a schematic illustration of a second alternative embodiment of the device for impeding airflow into a patient's lungs according to the present invention.

[0041] FIG. 4B is a schematic illustration of the device in FIG. 4A with a common inhalation/exhalation port.

[0042] FIG. 5A is a schematic view of a one-way valve used in the device for impeding airflow according to the present invention.

[0043] FIG. 5B is a schematic view of the one-way valve in FIG. 5A that is held open after ACD-CPR has ceased.

[0044] FIG. 5C is a schematic view of a one-way valve that is closed until a threshold pressure is present in the tube according to the present invention.

[0045] FIG. 6A is a schematic view of a spring biased inflow valve and a spring biased expiration valve to be used in accordance with the present invention.

[0046] FIG. 6B is a schematic view of FIG. 6A showing the operation of the valves during outflow of air.

[0047] FIG. 6C is a schematic view of FIG. 6A showing the operation of the valves during inflow of air.

[0048] FIG. 7 is a schematic view of a single valve that is spring biased from both sides to be used as an inflow valve and an expiration valve according to the present invention.

[0049] FIG. 8 is a schematic view of a flow restricting orifice to be used with a flow restrictive device according to the present invention.

[0050] FIG. 9 is a schematic view of an exemplary embodiment of the device for impeding airflow into a patient's lungs according to the present invention.

[0051] FIGS. 10A-10C are schematic views illustrating another embodiment of the present invention allowing for periodic patient ventilation through a bypassing valve.

[0052] FIG. 11 is a schematic view of an exemplary valving system for regulating airflow into a patient's lungs according to the present invention. The valving system is

shown with air being exhausted from a patient's lungs during compression of the patient's chest.

[0053] FIG. 12 illustrates the valving system of FIG. 11 during decompression or resting of the patient's chest.

[0054] FIG. 13 illustrates the valving system of FIG. 11 with a pressure-responsive valve being opened when the negative intrathoracic pressure in the patient's chest exceeds a threshold amount during decompression of the patient's chest.

[0055] FIG. 14 illustrates the valving system of FIG. 11 with a diaphragm being opened during injection of air into the housing when ventilating the patient.

[0056] FIG. 15 illustrates the valving system of FIG. 11 with a manually operable valve being opened to allow air into the patient's lungs upon return of spontaneous circulation.

[0057] FIG. 16A is a cutaway side view of exemplary valving system according to the present invention.

[0058] FIG. 16B is a top view of a deflector and a fenestrated mount of the valving system of FIG. 16A.

[0059] FIG. 16C is an alternative embodiment of the valving system of FIG. 16A.

[0060] FIG. 16D illustrates the valving system of FIG. 16A with a source of pressurized gas coupled to a pressure-responsive valve according to the invention.

[0061] FIG. 17 is a schematic view of an alternative embodiment of a valving system having a ball as a diaphragm.

[0062] FIG. 18 is a schematic view of a device for impeding air flow into the patient's lungs and for providing air to the patient's lungs when needed for ventilation.

[0063] FIG. 19 is a side view of one embodiment of a valving system having an adjustable pressure responsive valve according to the invention.

[0064] FIG. 20 is a cross sectional side view of the adjustable pressure responsive valve of FIG. 19.

[0065] FIG. 21 is a top view of the valve of FIG. 20.

[0066] FIG. 22 illustrates the valve of FIG. 21 with a cap being removed.

[0067] FIG. 23 is a schematic side view of a safety mechanism for a valving system that permits respiratory gases to freely flow to the patient's lungs through a ventilation passage according to the invention.

[0068] FIG. 24 illustrates the safety mechanism of FIG. 23 when actuated to prevent respiratory gases from flowing through the ventilation passage.

[0069] FIG. 25 is a schematic side view of a valving system having an integrated safety mechanism that permits respiratory gases to freely flow to the patient's lungs through an inflow valve according to the invention.

[0070] FIG. 26 illustrates a flow sensor and lever arm of the safety mechanism of FIG. 25 prior to actuation by the rescuer.

[0071] FIG. 27 illustrates the valving system of FIG. 25 when the safety mechanism is actuated by the rescuer to closed the inflow valve.

[0072] FIG. 28 illustrates the flow sensor and lever arm of FIG. 26 when actuated by the rescuer.

[0073] FIG. 29 is an end view of the valving system of FIG. 25.

[0074] FIG. 30 is a more detailed view of the inflow valve of FIG. 25 when in the open position.

[0075] FIG. 31 illustrates the inflow valve of FIG. 30 when in the closed position.

[0076] FIG. 32 is a side schematic view of one embodiment of a safety valve shown in a closed position according to the invention.

[0077] FIG. 33 illustrates the safety valve of FIG. 32 in an open position.

[0078] FIG. 34 is a side schematic view of another embodiment of a safety valve shown in a closed position according to the invention.

[0079] FIG. 35 illustrates the safety valve of FIG. 34 in an open position.

[0080] FIG. 36 is a side schematic view of yet another embodiment of a safety valve shown in a closed position according to the invention.

[0081] FIG. 37 illustrates the safety valve of FIG. 36 in an open position.

[0082] FIG. 38 is a schematic side view of an embodiment of a valving system having a safety valve that is in a closed position according to the invention.

[0083] FIG. 39 illustrates the valving system of FIG. 38 when the safety valve is moved to the open position during a gasp by a patient.

[0084] FIG. 40 illustrates the valving system of FIG. 38 during ventilation which causes the safety valve to move back to the closed position.

[0085] FIG. 41 is a schematic diagram of a valving system having a pressure gauge to measure pressures within the valving system according to the invention.

DESCRIPTION OF THE SPECIFIC EMBODIMENTS

[0086] According to the present invention, methods and devices for increasing cardiopulmonary circulation induced by chest compression and decompression when performing cardiopulmonary resuscitation are provided. Such methods and devices may be used in connection with any method of CPR in which intrathoracic pressures are intentionally manipulated to improve cardiopulmonary circulation. For instance, the present invention would improve standard manual CPR, "vest" CPR where a circumferential collar is compressed in a repetitive manner to promote blood flow from the heart, CPR with a newly described Hiack Oscillator ventilatory system which operates essentially like an iron-lunglike device, phrenic nerve stimulators, including those described in copending U.S. application Nos. 09/095,916, filed Jun. 11, 1998; 09/197,286, filed Nov. 20, 1998; 09/315,396, filed May 20, 1999; and 09/533,880, filed Mar. 22,

2000, the complete disclosures of which are herein incorporated by reference, interposed abdominal compression-decompression CPR, and active compression-decompression (ACD) CPR techniques. Although the present invention may improve all such techniques, the following description will refer primarily to improvements of ACD-CPR techniques in order to simplify discussion. However, the claimed methods and devices are not exclusively limited to ACD-CPR techniques.

[0087] The proper performance of ACD-CPR to increase cardiopulmonary circulation is accomplished by actively compressing a patient's chest with an applicator body. Preferably, this applicator body will be a suction-type device that will adhere to the patient's chest, such as the AMBU® CardioPump™, available from AMBU International, Copenhagen, Denmark. After the compression step, the adherence of the applicator body to the patient's chest allows the patient's chest to be lifted to actively decompress the patient's chest. The result of such active compression-decompression is to increase intrathoracic pressure during the compression step, and to increase the negative intrathoracic pressure during the decompression step thus enhancing the blood-oxygenation process and enhancing cardiopulmonary circulation. ACD-CPR techniques are described in detail in Todd J. Cohen et al., *Active Compression-Decompression Resuscitation: A Novel Method of Cardiopulmonary Resuscitation*, American Heart Journal, Vol. 124, No. 5, pp. 1145-1150, November 1992; Todd J. Cohen et al., *Active Compression-Decompression: A New Method of Cardiopulmonary Resuscitation*, The Journal of the American Medical Association, Vol. 267, No. 21, Jun. 3, 1992; and J. Schultz, P. Coffeen, et al., *Circulation*, 89:684-693, 1994. These references are hereby incorporated by reference.

[0088] The present invention is especially useful in connection with standard and ACD-CPR techniques. In particular, the invention improves standard and ACD-CPR by providing methods and devices which impede airflow into a patient's lungs to enhance negative intrathoracic pressure during the decompression of the patient's chest, thus increasing the degree and duration of a pressure differential between the thorax (including the heart and lungs) and the peripheral venous vasculature. Enhancing negative intrathoracic pressure with simultaneous impedance of movement of gases into the airway thus enhances venous blood flow into the heart and lungs and increases cardiopulmonary circulation.

[0089] In a broad sense, the present invention provides for occluding a patient's airway to prevent foreign (outside) air from flowing to a patient's lungs during the active decompression step of ACD-CPR to enhance and sustain the duration of negative intrathoracic pressure and enhance blood oxygenation and cardiopulmonary circulation during both active decompression and the subsequent compression phase. The patient's airway may be occluded or inflow of gases impeded by any suitable device or mechanism such as by an endotracheal tube, a device attached to an endotracheal tube, a facial mask, a mouth piece used in mouth-to-mouth resuscitation, oropharyngeal airway, laryngeal mask airway, and the like.

[0090] A further aspect of the present invention provides for allowing impeded air to flow into the patient's lungs during the active decompression step of ACD-CPR in order

to provide some ventilation to the patient while still enhancing the extent and duration of negative intrathoracic pressure to enhance blood oxygenation. Impeding airflow to the patient's lungs may be accomplished by any flow restrictive element such as an orifice, a one-way valve, a spring biased or other valve which is set to open when the negative intrathoracic pressure is in the range from about 0 cm H₂O to -100 cm H₂O, and more preferably from about -3 cm H₂O to about -30 cm H₂O. A valve designed to open at a threshold pressure value may be either fixed or variable, i.e., the pressure at which the valve opens may be adjusted or may be permanently fixed. Further, examples of pressure-responsive valves that may be used include, for example, an electromagnetically driven valve or a valve constructed of any deflectable material that will deflect when the threshold pressure is exceeded. As one specific example, the valve may be constructed of a magnetically charged piece of material with a narrow tolerance that is attracted to a gate. This valve will open, i.e. separate from the gate, when the magnetically charged gate pressure is exceeded. In this way, when the negative intrathoracic pressure is exceeded, the valve will be pulled away from the gate to permit gases to flow to the lungs.

[0091] In some cases, a safety mechanism may be provided to permit respiratory gases to freely flow to the patient's lungs until the safety mechanism is actuated by the rescuer. In this way, the valving system may be coupled to the patient but will only impede patient inspiration until actuated by the rescuer.

[0092] Another aspect of the invention provides for air to be impeded from leaving the patient's lungs during compression of the patient's chest to further enhance cardiopulmonary circulation by enhancing intrathoracic pressure during the compression phase. Typically, air is impeded from leaving the lungs during the compression phase when the positive intrathoracic pressure is in the range from about 2 cm H₂O to 50 cm H₂O, and more preferably from about 2 cm H₂O to about 20 cm H₂O. Valves that may be used to accomplish such a feature include, for example, a spring valve, a diaphragm valve, include diaphragms constructed of silicone, and a magnetically charged plate that is coupled to a gate. In this manner, when the positive pressure exceeds the magnetic force, the plate is forced away from the gate to permit the gases to exit the lungs.

[0093] Another aspect of the present invention provides for ventilating the patient during CPR. Ventilation of the patient in one embodiment is performed at about every two to 20 compressions, preferably twice every fifteen compressions, thus providing sufficient fresh air for adequate gas exchange with the blood in the lungs to the patient. Ventilating the patient may be accomplished by any device or method suitable such as by mouth-to-mouth resuscitation, by a compressible or collapsible structure, by a ventilatory bag such as the AMBU bag available from AMBU, Copenhagen, Denmark, or the like. Ventilation could also be superimposed on the compression phase to further augment positive intrathoracic pressure. Furthermore, periodic ventilation could be performed either through the impeding step or by bypassing the impeding step altogether.

[0094] In an alternative embodiment, ventilation may be provided by introducing oxygen-enriched respiratory gases through the pressure-responsive valve that permits gases

into the lungs during the decompression step once a certain threshold negative intrathoracic pressure is exceeded. This could be introduced under pressure or at atmospheric pressure. In this way, during each decompression step, respiratory gases may be supplied to the lungs to ventilate the patient. Use of a pressurized gas is advantageous in that more respiratory gases may be supplied to the lungs once the pressure responsive valve opens. The pressurized gas may be supplied by connecting a pressurized gas source, such as a pressurized tank or bag of O₂, to the back side of the pressure-responsive valve using a length of tubing. Conveniently, a regulator may be positioned between the pressure source and the valve to regulate the pressure and/or flow rate of the gas supplied from the pressure source. The pressure may be regulated such that it is less than the actuating pressure of the valve, e.g. by about 1 to 3 cm H₂O, so that the valve will not prematurely open. For example, if respiratory gases are to be supplied to the patient when the negative intrathoracic pressure exceeds -14 cm H₂O, the pressure of the gas from the gas source must be set to less than 14 cm H₂O.

[0095] When ventilating a patient, the valves of the invention may be modified to regulate the flow rate of air into the lungs. This may be accomplished for example, by including a flow regulator, valve, restriction, reduced size orifice or the like within or associated with the valve so that as respiratory gases are injected into the valve, their flow rate is limited below a threshold amount as the gases enter the patient's airway. By regulating the flow rate of injected respiratory gases, the pressure on the esophagus may be kept within certain limits to prevent gastronomic distention. For example, a reduced size orifice may be provided at or near the exit opening of the valve system housing to regulate the gas flow rate before the gases enter the patient's airway. In this way, a technique is provided to ensure that substantially all of the injected respiratory gases enter the patient's lungs.

[0096] One significant advantage of the invention is the ability to increase a person's blood pressure. By interfacing the valving systems of the invention with spontaneously breathing patient's, the pressure responsive valve is able to increase the negative intrathoracic pressure when the person inhales. By so doing, more blood is returned to the right heart, thereby increasing the person's blood pressure. For such cases, the pressure responsive valve may be set to a pressure in the range from about 0 cm H₂O to about -20 cm H₂O.

[0097] Examples of situations where the valving systems of the invention may be used to increase blood pressure include those where a spontaneously breathing patient has experienced blood loss, or after receiving a drug (including an anesthetic agent) experiences a decrease in blood pressure. Patients with low blood pressure often suffer from insufficient blood returning to the heart after each beat. This results in a decrease in forward blood flow out of the heart and eventually to low blood pressure. By interfacing the pressure responsive inflow valve to the airway, the amount of venous return to the right heart is increased to increase blood pressure. Another example is where a spontaneously breathing patient is in shock secondary to profound blood loss, and needs increased blood flow to the right heart. As a further example, such techniques may be used with pilots or astronauts to increase blood flow back to the right heart in high gravitational states, and in patients who suffer from a

rapid decrease in blood pressure due to vasovagal or vasodepressor syncope. For example, a spontaneously breathing patient may be treated for low blood pressure secondary to vasovagal syncope using the valving systems of the invention.

[0098] On one option, any of the valving systems may include an electronic device and an associated speaker to produce voice prompts on how to perform CPR using the valving systems. Such voice prompts may have instructions for interfacing the valving system, applying chest compressions, giving ventilations, and the like. Also, a metronome may be provided to assist the rescuer in providing appropriate chest compressions. Such techniques are described in copending U.S. application No. _____, filed on the same date as the present application (attorney docket no. 16354-004300), the complete disclosure of which is herein incorporated by reference.

[0099] The valving systems of the invention may also incorporate or be associated with sensor that are used to detect changes in intrathoracic pressures. In this way, spontaneous patient breathing may be detected. This in turn may be used to control the valving system so that the patient may breathe without any resistance once the sensor is activated by achieving a certain intrathoracic pressure one or more times. Examples of such sensors are described in U.S. Pat. No. 6,155,257, the complete disclosure of which is herein incorporated by reference.

[0100] Referring now to FIG. 1, a graph illustrating thoracic pressure changes over time when compressing and decompressing the patient's chest is shown. Area 10 represents the amount of thoracic pressure during the compression phase of ACD-CPR. Cross-hatched area 12 represents the negative thoracic pressure during the decompression step of ACD-CPR without a flow restrictive means to restrict the flow of air into the patient's lungs. Double cross-hatched area 14 represents the increase in negative thoracic pressure when the patient's airway is occluded according to the present invention during the decompression step of ACD-CPR. The significance of the increase in negative intrathoracic pressure during the decompression step is that more venous blood is forced into the chest from the peripheral venous vasculature. Consequently, more blood is allowed to be oxygenated and more blood is forced out of the chest during the next compression.

[0101] In an exemplary embodiment, airflow may be impeded to the patient's lungs during decompression of the patient's chest by placing a ventilatory mask over the patient's mouth and nose. The ventilatory mask also has a pressure-responsive valve attached to prevent airflow to the patient's lungs until the negative intrathoracic pressure of the patient reaches a threshold amount. Also attached to the mask and the pressure-responsive valve is a ventilatory source to provide ventilation to the patient. The ventilatory source may be any device or apparatus suitable for properly ventilating the patient. Preferably, the ventilation source will be an AMBU bag. When ventilation is needed, the AMBU bag may be squeezed to force air into the patient's lungs. The AMBU bag is described in U.S. Pat. No. 5,163,424 which is incorporated herein by reference.

[0102] In an alternative embodiment, a ventilation source, preferably an AMBU bag, is used in connection with an improved endotracheal tube. A pressure-responsive valve or other flow restrictive element is placed between the AMBU

bag and the endotracheal tube. Preferably, the valve will be positioned within a tube that connects the AMBU bag to the endotracheal tube. The combination of the endotracheal tube with the AMBU bag with adapter can be included in the definition of a "ventilation tube." Before ACD-CPR is performed on the patient, the endotracheal tube is placed in the patient's trachea. During decompression of the patient's chest, the valve prevents airflow to the patient's lungs until the intrathoracic pressure reaches a threshold amount. Additionally, the AMBU bag may be used to ventilate the patient at a desired time. Also included in this embodiment is a one-way expiration valve. This valve allows for expiration of air from the patient during the compression step.

[0103] In a modification of either of the first two embodiments, a pressure-responsive expiration valve may also be inserted between the AMBU bag (or comparable ventilation source) and the mask or endotracheal tube. This valve works in a similar manner to the pressure-responsive valve which restricts airflow into the patient's lungs. However, the pressure-responsive expiration valve restricts airflow from the patient's lungs during the compression step of ACD-CPR. An equivalent valve is a positive end-expiratory pressure (PEEP) valve available from AMBU International, Copenhagen, Denmark. Use of such a pressure-responsive expiration valve during compression may further increase intrathoracic pressure and thereby force more blood out of the thorax.

[0104] In another alternative embodiment, an improved endotracheal tube is used to restrict airflow into the patient's lungs during the active decompression step. Included in the endotracheal tube is a flow restrictive element which operates to impede air from flowing into the patient's lungs. When the endotracheal tube is inserted into the patient's trachea and the patient's chest is actively decompressed, the flow restrictive element impedes air from flowing to the patient's lungs slowing the rise in intrathoracic pressure and thus enhancing blood oxygenation.

[0105] When using the improved endotracheal tube during ACD-CPR, periodic ventilation of the patient will usually still be performed to enhance gas exchange to the patient. With the improved endotracheal tube, such manual ventilation may be accomplished by placing a ventilation source at the opening of the endotracheal tube to force oxygen through the endotracheal tube and into the patient's lungs.

[0106] Referring now to FIG. 2A, a schematic view illustrating airflow through a ventilation circuit 20 when compressing a patient's chest according to the present invention is shown. During ACD-CPR, the chest is actively compressed forcing air out of the lungs. This air is allowed to expire through a one-way expiration valve 22 within a ventilation circuit 20.

[0107] Referring now to FIG. 2B, the same schematic is shown illustrating airflow through the ventilation circuit 20 when decompressing the patient's chest. When the patient's chest is actively decompressed, a negative intrathoracic pressure is created. When this pressure reaches a threshold amount, the inflow valve 24 will open causing air to flow through the ventilation circuit 20 into the patient's lungs. Air is allowed into the ventilation circuit 20 through a ventilation valve 26 and into a ventilation bag 28. From the ventilation bag 28, the air passes through the inflow valve 24 when the negative intrathoracic pressure reaches the thresh-

old amount. The ventilation bag 28 is also used to manually ventilate the patient during ACD-CPR as required.

[0108] The method as discussed in connection with FIGS. 2A and 2B requires the chest to be compressed in the range from about 3.5 cm to 5 cm per compression and at a rate from about 60 to 100 compressions per minute for adults.

[0109] Referring now to FIG. 3, a schematic illustration of a first alternative embodiment of a device 35 for impeding airflow into a patient's lungs according to the present invention is shown. The device 35 comprises an endotracheal tube 36 which is placed into the patient's trachea and provides a ventilation passageway. Connected to the endotracheal tube 36 is a transition tube 38 which connects the endotracheal tube 36 to the ventilation bag 28. Although the endotracheal tube 36 is shown connected to the ventilation bag 28, the endotracheal tube 36 can be used alone or in connection with the ventilation bag 28. The ventilation bag 28 can comprise any type of ventilation source capable of ventilating the patient such as a compressible or collapsible structure. Preferably, the ventilation bag 28 consists of an AMBU bag. Attached or connected to the end of the ventilation bag 28 is a one-way ventilation valve 26. The ventilation valve 26 serves to introduce air into the device 35. Attached or connected to the transition tube 38 is an inflow pressure-responsive valve 24. The inflow valve 24 is biased so that it opens when the negative intrathoracic pressure in the patient's chest reaches a threshold amount. As shown, only one inflow valve 24 is included in the device 35. However, the invention is not limited to only one inflow valve 24. Alternatively, a plurality of inflow valves 24 could be connected in series along the ventilation tube 38. The inflow valve 24 is also not limited to being connected in the center of the transition tube 38, but may be positioned anywhere along the transition tube 38. The inflow valve 24 could be permanently attached to the ventilation bag 28 or transition tube 38 or could be detachable. Alternatively, the inflow valve 24 could be connected to the ventilation bag 28 itself or to the endotracheal tube 36.

[0110] The device 35 also contains a one-way expiration valve 22 which allows for air to be expired from the patient's lungs. This generally occurs during the compression phase of ACD-CPR. To insure that the air expired from the patient's lungs will exit through the expiration valve 22, a one-way fish mouth valve 37 (the preferred valve) or any other type of one-way valve can be placed between the inflow valve 24 and the expiration valve 22. Alternatively, the inflow valve 24 itself may be configured as a one-way valve. In either case, air flowing from the endotracheal tube 36 toward the ventilation bag 28 will be forced to expire through the expiration valve 22.

[0111] The device 35 may be further modified to include a pressure-responsive expiration valve 39 (not shown) located between the endotracheal tube 36 and the transition tube 38. The pressure-responsive expiration valve works in a reverse manner to that of the inflow valve 24. Specifically, the pressure-responsive expiration valve is biased so that during the compression step of ACD-CPR, air will be allowed to expire from the patient's lungs only when the intrathoracic pressure reaches a threshold amount. The increase in intrathoracic pressure caused by the pressure-responsive expiration valve 39 during compression may assist in forcing more blood out of the thorax and reduce atelectasis of the lungs.

[0112] The purpose of the ventilation bag 28 is to provide ventilation to the patient during ACD-CPR. When the ventilation bag 28 comprises an AMBU bag or similar bag used for ventilation, ventilation of the patient may be performed by merely squeezing the AMBU bag with a human hand. This forces air to the patient's lungs as desired.

[0113] Referring to FIG. 4A, a second alternative embodiment of the device for impeding airflow into a patient's lungs according to the present invention is shown. This particular embodiment is a modified and improved endotracheal tube. Hence, the second alternative embodiment comprises an endotracheal tube 36 having two lumens at its proximal end. The first lumen is an outflow lumen 40, and the second lumen is an inflow lumen 42. Located within outflow lumen 40 is a one-way pressure-responsive expiration valve 44 which operates in a manner similar to that discussed in connection with FIG. 3, except that the expiration valve 44 is specifically designed as a one-way valve. Located within inflow lumen 42 is a one-way pressure-responsive inflow valve 45 which operates to impede airflow to the lungs as discussed in connection with FIG. 3, except that the inflow valve 45 is also specifically designed as a one-way valve. Also shown in inflow lumen 42 and outflow lumen 40 is an O-ring 46 which will be discussed subsequently. Inflow valve 45 and expiration valve 44 are designed as one-way valves so that during the compression phase, air can only be expired from the patient through the endotracheal tube 36 when the intrathoracic pressure reaches a threshold amount. At that moment, expiration valve 44 opens and air expires from the patient through the outflow lumen 40. During decompression, air cannot flow through the endotracheal tube 36 to the patient's lungs until the negative intrathoracic pressure reaches a threshold amount. At that moment, inflow valve 45 opens allowing air to flow through inflow lumen 42 to the patient's lungs. Air is prevented from entering through the outflow lumen 40 because of the one-way expiration valve 44.

[0114] Ventilation is possible with the embodiment disclosed in FIGS. 4A and 4B if the inflow lumen 42 is connected to a ventilation source such as a ventilation bag. When the ventilation bag is squeezed, air is allowed to flow through the inflow lumen 42, through the endotracheal tube 36, and to the patient's lungs. In this embodiment, expiration valve 44 is designed so that during ventilation, expiration valve 44 will remain temporarily closed preventing air flowing through inflow lumen 42 escape through outflow lumen 40.

[0115] FIG. 5A is a schematic view of a one-way inflow valve 45 used in a device for impeding airflow according to the present invention. The inflow valve 45 operates so as to allow air only to flow in one direction. As shown, the spring biased inflow valve 45 is completely open. However, the invention also functions properly if the spring biased inflow valve 45 or the spring biased expiration valve 44 are not fully open. Upon successful completion of ACD-CPR, the O-ring 46 that is positioned above the inflow valve 45 is repositioned so that inflow valve 45 is held open as shown in FIG. 5B. Such a positioning of O-ring 46 allows for unimpeded airflow to the patient once there is a return of spontaneous circulation and the inflow valve 45 is no longer needed. An O-ring 46 is also used in a similar manner to lock the one-way expiration valve 44 in an open position upon return of spontaneous circulation. FIG. 5C illustrates the

one-way inflow valve 45 in a closed position. When closed, the inflow of air through the inflow valve 45 is occluded.

[0116] FIG. 6A illustrates an inflow valve 47 that is spring biased and an expiration valve 48 that is also spring biased. The inflow valve 47 and the expiration valve 48 are connected in series and may be used in the first alternative embodiment as discussed in connection with FIG. 3, or with the preferred embodiment discussed following in connection with FIG. 9. As shown in FIG. 6C, during the active decompression step, the inflow valve 47 is biased such that it will open when the negative intrathoracic pressure reaches a threshold amount. During the compression phase of ACD-CPR the expiration valve 48 will open to allow air to expire from the patient's lungs when the intrathoracic pressure within the patient's chest reaches a threshold amount as shown in FIG. 6B. Since neither inflow valve 47 nor expiration valve 48 are one-way valves, a fish mouth valve 37 used in connection with a one-way expiration valve 22 as discussed in connection with FIG. 3 must be used. Other valves designed upon a similar principle as the fish mouth valve combination with a one-way expiration valve could also be used. Only one inflow valve 24 and one positive end pressure valve 44 are shown in FIGS. 6A-6C. However, a plurality of inflow valves 47 and/or expiration valves 48 may be connected in a permanent or detachable manner in series to impede the inflow and outflow of air.

[0117] Although the valves in FIGS. 6A-6C are shown as being spring-biased, any other valves designed upon a similar principle would work equally as well. The use of such valves as disclosed in FIGS. 6A-6C is only one embodiment and valves constructed according to various other methods and materials is also within the scope of the invention.

[0118] As shown in FIG. 7, the inflow valve 47 and the expiration valve 48 may be combined into one joint valve 49 as shown. The joint valve 49 will operate in a manner similar to the two valves 47 and 48 as described in connection with FIG. 6.

[0119] FIG. 8 illustrates a flow restricting orifice 50 to be used to either impede the airflow into or out of a patient's lungs. The flow restricting orifice 50 operates so that during the decompression step of ACD-CPR airflow is impeded from entering into the patient's lungs, thus increasing the negative intrathoracic pressure. During the compression step, the flow restricting orifice 50 operates to increase the thoracic pressure in the patient's chest by restricting air from existing from the patient's lungs.

[0120] FIG. 9 illustrates an exemplary embodiment for impeding airflow into a patient's lungs according to the present invention. As shown, the device 51 comprises a ventilation bag 28 that is connected to a facial mask 52 by an inflow valve 24 and an expiration valve 22. Although the facial mask 52 is shown connected to the ventilation bag 28, the facial mask 52 can be used alone or in connection with the ventilation bag. Between the inflow valve 24 and the expiration valve 22 is a one-way fish mouth valve 37 or any other type of one-way valve to prevent air from exiting the patient's lungs and flowing to the ventilation bag 28. The ventilation bag 28 also contains a one-way ventilation valve 26 for allowing air to inflow into the device 51. The exemplary embodiment operates in a manner similar to that of the first alternative embodiment as discussed in connec-

tion with **FIG. 3**. However, instead of inserting an endotracheal tube **36** into the patient's airway, the facial mask **52** is placed over the patient's mouth and nose. A facial strap **54** (not shown) may also be wrapped around the head of the patient to secure the ventilation mask **52** to the patient's face.

[0121] Device **51** is preferably used in connection with an oral airway device (not shown) to prevent the patient's airway from becoming occluded, e.g. by the patient's tongue. The oral airway device can be any device that is used to keep the patient's tongue from slipping backward and occluding the airway. Preferably, the oral airway device will be curved and constructed of a plastic material and may or may not be attached to the device **51**.

[0122] During the decompression phase of ACD-CPR, air is prevented from entering into the patient's lungs through the threshold inflow valve **24** thus increasing the negative intrathoracic pressure. During the compression phase, air is allowed to expire from the patient's lungs through the expiration valve **22**. Also, the patient can be ventilated during ACD-CPR by manually squeezing the ventilation bag **28**. Consequently, the preferred embodiment serves to enhance cardiopulmonary circulation by increasing the negative intrathoracic pressure to force more blood into the chest from the peripheral venous vasculature.

[0123] **FIGS. 10A-10C** show another embodiment of the present invention which allows the patient to be ventilated by bypassing the impeding step. The embodiment comprises a ventilation tube **60** with a proximal end **62** and a distal end **64** that is connected to the patient. The ventilation tube **60** has a one-way bypass valve **66** and a one-way pressure responsive valve **68**. The ventilation tube **60** may also have a manual switch **70** attached to the bypass valve **66** and extending through a side of the ventilation tube **60**. As shown in **FIG. 10A**, the switch **70** may be set in a closed position so that the one-way pressure responsive valve **68** opens when the threshold pressure of the valve **68** has been exceeded. At this point, the valve **68** opens allowing for ventilation of the patient. As shown in **FIG. 10B**, the one-way pressure responsive valve **68** may be bypassed altogether by manually placing the switch **70** in the open position so that the bypass valve **66** is opened allowing air to flow to the patient. **FIG. 10C** illustrates the operation of the bypass valve **66** with the switch **70** in an inactive mode. Here, the rescuer performing ventilation may do so without added resistance from the impedance step as in **FIG. 10A**. Instead, bypass valve **66** opens only when the pressure at the proximal end of the tube **62** is greater than atmospheric pressure (0 mmHg), preferably in a range from about 0 mmHg to 5 mmHg. During decompression of the patient's chest, the one-way bypass valve **66** remains closed unless atmospheric pressure is exceeded. Thus, the patient is ventilated only when the rescuer performing ventilation causes the pressure at the proximal end of the tube **62** to exceed atmospheric pressure. The function of the one-way bypass valve **66** may be performed by many different threshold valve designs which are known in the art.

[0124] In another aspect of the invention, an exemplary valving system is provided for enhancing the duration and extent of negative intrathoracic pressure during the decompression phase of CPR while still providing adequate ventilation to the patient. The valving system is employed to

slow the rapid equilibrium of intrathoracic pressure in the chest during decompression by impeding or inhibiting the flow of air into the patient's chest. Lowering of the intrathoracic pressure in this manner provides a greater coronary perfusion pressure and hence forces more venous blood into the thorax. The valving system can be employed in a variety of CPR methods where intrathoracic pressures are intentionally manipulated to improve cardiopulmonary circulation, including "vest" CPR, CPR incorporating a Heimlich ventilatory system, intraposed abdominal compression-decompression CPR, standard manual CPR, and the like, and will find its greatest use with ACD-CPR.

[0125] Referring to **FIGS. 11-15**, an exemplary embodiment of a valving system **100** is shown schematically. The valving system **100** includes a housing **101** having an upstream region **102** and a downstream region **104**. Held between the upstream region **102** and downstream region **104** is a diaphragm **106**. The diaphragm **106** is preferably a flexible or elastomeric membrane that is held over the downstream region **104** to inhibit air from flowing from the upstream region **102** to the downstream region **104** when the pressure in the downstream region **104** is less than the pressure in the upstream region **102**, except when positive pressure, i.e. greater than atmospheric, is developed in the upstream region **102** when ventilating the patient. The valving system **100** further includes a valve **108** having a plug **110**. As described in greater detail hereinafter, the valve **108** is included to provide ventilation to the patient when opened. The valve **108** can be manually opened by axial translation or it can be automatically opened when the pressure in the downstream region **104** reaches or exceeds a threshold amount, or both. Included at the upstream region **102** is an air intake opening **112** and an air exhaust opening **114**. Air is delivered into the housing **101** through the air intake opening **112**, while air is exhausted from the housing **101** through the air exhaust opening **114**. An accordion valve **116**, fish mouth valve, or the like is provided between the air intake opening **112** and the air exhaust opening **114**. As described in greater detail hereinafter, the accordion valve **116** is used to prevent air that is injected into the air intake opening **112** from exiting the air exhaust opening **114** when ventilating the patient. A filter **117** is provided for filtering air injected into the housing **101**. Optionally, a filter **119** can be provided in the downstream region **104** for preventing excess body fluids and airborne pathogens from entering into the system **100**.

[0126] Operation of the valving system **100** during compression of a patient's chest is illustrated in **FIG. 11**. As the patient's chest is compressed, air is forced from the patient's lungs and into the downstream region **104**. The air forced into the downstream region **104** is directed against the diaphragm **106** forcing the diaphragm into an ambient pressure region **118**. Air in the downstream region **104** is then allowed to escape into the upstream region **102** where it is exhausted through the air exhaust opening **114**. Optionally, the diaphragm **106** can be biased so that it will not be forced into the ambient pressure region **118** until the pressure within the downstream region **104** is about 2 cm H₂O or greater, and more preferably at about 2 cm H₂O to 4 cm H₂O.

[0127] Operation of the valving system **100** during decompression (or resting) of the patient's chest is illustrated in **FIG. 12**. As the patient's chest is actively lifted (or allowed

to expand on its own), air is drawn from the downstream region 104 and into the patient's lungs, thereby reducing the pressure in the downstream region 104. The resulting pressure differential between the regions 102, 104 holds the diaphragm 106 over the downstream region 104 to prevent air from the upstream region 102 from flowing to the downstream region 104. In this way, air is inhibited from flowing into the patient's lungs during decompression of the patient's chest, thereby lowering the intrathoracic pressure to increase the coronary perfusion pressure and to force more venous blood into the thorax.

[0128] Various ways of providing ventilation to the patient using the valving system 100 are described in FIGS. 13-15. FIG. 13 illustrates airflow into the downstream region 104 and to the patient's lungs during decompression of the patient's chest after a threshold amount of negative intrathoracic pressure has been reached. Ventilation in this manner is advantageous in that the valving system 100 can be employed to produce at least a threshold amount of intrathoracic pressure to enhance blood flow into the heart and lungs. Once such a pressure is reached, some air is allowed to flow to the patient's lungs to ventilate the patient.

[0129] Air is allowed to enter the downstream region 104 when the threshold amount of intrathoracic pressure is reached by configuring the valve 108 to be a threshold valve. The valve 108 can be configured in a variety of ways, with a primary function being that the valve 108 allows air to flow into the downstream region 104 when a threshold amount of intrathoracic pressure is reached. This is preferably accomplished by configuring the plug 110 to be flexible in one direction so that when the pressure in the downstream region 104 reaches or exceeds the threshold amount, the plug 110 is flexed to provide an opening 126 between the upstream region 102 and downstream region 104. When the plug 110 is flexed, air flows from the lower pressure upstream region 102 into the downstream region 104 and to the patient's lungs. The plug 110 therefore acts as a one-way valve allowing air to flow from the upstream region 102 into the downstream region 104 when the threshold amount is reached, but does not allow airflow from the downstream region 104 to the upstream region 102. Preferably, the plug 110 will flex to open when the pressure within the downstream region 104 is in the range from about 0 mm H₂O to 50 cm H₂O, more preferably at about 10 cm H₂O to 40 cm H₂O, and more preferably at 15 cm H₂O to about 20 cm H₂O. Alternatively, the valve 108 can be placed in the downstream region 104 so that air flows into the downstream region 104 directly from the atmosphere when the valve 108 is open. Although shown as a flexible plug, it will be appreciated that other types of valve arrangements may be used. For example, plug 110 could be replaced with a spring biased valve that closes opening 126 until the negative intrathoracic pressure overcomes the force of the spring to open the valve in a manner similar to that described in connection with FIG. 16A.

[0130] Ventilating the patient by injecting air into the upstream region 102 is illustrated in FIG. 14. As air is injected through the intake opening 112, it passes into the accordion valve 116 and forces the valve 116 against a wall 120 and covers a hole 122 in the wall 120 to prevent airflow through the exhaust opening 114. When the accordion valve 116 is closed, air flows through a wall 124 of the valve 116 and into the upstream region 102. Alternatively, a fish mouth

valve can be used in place of the accordion valve 116. Upon injection of the air into the upstream region 102, the pressure within the upstream region 102 becomes greater than the pressure in the ambient pressure region 118 and causes the diaphragm 106 to be drawn into the ambient pressure region 118. An opening between the upstream region 102 and the downstream region 104 is created allowing air to flow into the downstream region 104 and into the patient's lungs. Preferably, the patient will be manually ventilated by injecting air into the intake opening 112 one time every five compressions of the chest, and more preferably about two times every 15 compressions of the chest using two rescuers. Similarly, ventilating the patient can occur through the same port where the spring-biased valve is located, such as through valve 160 of FIG. 16A.

[0131] Configuration of the valving system 100 upon return of spontaneous circulation is illustrated in FIG. 15. When the patient's circulation is restored, the valve 108 is manually opened by translating the valve 108 to remove the plug 110 from aperture 126. The upstream region 102 and downstream region 104 are then placed in communication to allow air to be freely exchanged between each of the regions 102, 104. Although shown extending through the upstream region 102, the valve 108 can alternatively be placed anywhere along the downstream region 104.

[0132] The valve 108 can be configured as a pressure-responsive valve (see FIG. 13), as a manually operable valve (see FIG. 15), or both. Further, the valving system 100 can alternatively be provided with two or more valves that are similar to the valve 108. For example, one valve could be non-translatably held in the housing 101 and provided with a pressure-responsive plug 110, with the other valve being translatably mounted. In this manner, the valve with the flexible plug functions as a pressure-responsive valve and opens when the threshold pressure is reached, while the translatable valve functions to place the regions 102, 104 in communication upon manual operation after spontaneous circulation is achieved.

[0133] Referring to FIGS. 16A and 16B, an exemplary embodiment of a valving system 130 will be described. The valving system 130 is constricted of a housing 132 having an intake opening 134, an exhaust opening 136, and a delivery opening 138. Included in the exhaust opening 136 is a one-way valve 140 which allows air to flow from the housing 132 and out the exhaust opening 136. An accordion valve 140 is provided between the intake opening 134 and an exhaust opening 136 to prevent air injected into the intake opening 134 from exiting through the exhaust opening 136. Preferably, the intake opening 134 is configured to be attachable to a respiratory device, such as a respiratory bag (including an AMBU bag), a ventilator, a mouthpiece or port for mouth-to-mouth breathing through the system 130, or the like. The delivery opening 138 is preferably configured for connection to an endotracheal tube or other airway tube, a sealed facial mask, a laryngeal mask, or the like.

[0134] Within the housing 132 is an upstream region 142, a downstream region 144, and an ambient pressure region 146. Separating the upstream region 142 from the downstream region 144 is a diaphragm 148. The diaphragm 148 is preferably constructed of an elastomeric material. The housing 132 is preferably cylindrical in geometry at the downstream region 144, with the diaphragm 148 resting on

the cylinder during ambient conditions. During decompression of the patient's chest, the reduction in pressure in the downstream region 144 draws the diaphragm 148 against the end of the cylinder to prevent exchange of air between the upstream region 142 and downstream region 144. During compression of the patient's chest, air is forced into the downstream region 144 to force the diaphragm 148 into the ambient pressure region 146 so that the air exhausted from the patient's chest can be exhausted through the exhaust opening 136.

[0135] As shown best in FIG. 16B, the valving system 130 is further provided with a fenestrated mount 150. In one aspect, the fenestrated mount 150 serves as a mount for holding the diaphragm 148 over the downstream region 144. The fenestrated mount 150 further provides the ambient pressure region 146. Fenestrations 152 are provided in the mount 150 to allow air to be exchanged through the mount 150. Included on the mount 150 is a deflector 154 for deflecting air around the fenestrated mount 150. Various other deflectors 156 are provided in the housing 132 for directing airflows between the regions 142 and 144. A filter 158 is provided in the housing 132 to filter air injected into the housing 132. Optionally, a filter 159 can be provided to prevent excess body fluids from entering into the system 130.

[0136] The valving system 130 further includes a threshold valve 160 at the downstream region 144. When the pressure within the downstream region 144 is less than the threshold amount, the threshold valve 160 is opened to allow air to flow into the downstream region 144. The threshold valve 160 includes a spring 162 which is configured to extend when the threshold amount is reached. Alternatively, the threshold valve 160 can be configured similar to the valve 110. Other configurations which allow the for air to enter the downstream region 144 when the desired intrathoracic pressure is reached or exceeded can also be provided. For example, in a further alternative, the diaphragm 148 can be constructed to function as a threshold valve to allow air to flow into the patient's lungs when a threshold amount of intrathoracic pressure is reached. The diaphragm 148 can be fashioned as a threshold valve by constructing the diaphragm 148 of an elastomeric material and by providing at least one hole near the periphery. When the diaphragm rests on the cylinder forming the downstream region 144, the hole is positioned beyond the periphery of the cylinder and in the upstream region 142. As a vacuum is created in the downstream region 144, the diaphragm is drawn into the downstream region 144 until the hole is stretched over the cylinder and overlaps with both the upstream region 142 and the downstream region 144.

[0137] In this way, a fluid path is provided between the regions 142 and 144 when the threshold pressure is reached in the downstream region 144. Another alternative of a threshold valve 111 is illustrated in FIG. 16C. The valve 111 is pivot mounted within the downstream region 144 and is biased closed by a spring 113. When the threshold pressure within the downstream region 144 is reached, the spring 113 is compressed and air is drawn into the downstream region 144.

[0138] Referring back to FIG. 16A, the threshold valve 160 can optionally be provided within the housing 132 at the upstream region 142. The threshold valve 160 can further

optionally be provided with an on/off switch for opening the valve 160 when spontaneous circulation is achieved. In this manner, a rescuer can open the valve 160 to allow for free exchange of air to the patient's lungs when needed. In one alternative as shown in FIG. 16C, the mount 150 can be slidably mounted within the housing 132 so that the mount 150 can be vertically raised to lift the diaphragm 148 from the downstream region 144 upon successful resuscitation of the patient, thereby providing a free flow of air to the patient. The mount 150 can be slidably mounted within the housing 132 by attaching the mount 150 to an extension member 133 that is slidable within the housing 132. The member 133 preferably includes the intake and exhaust openings 134 and 136. In this way, an easy grasping surface is provided when translating the member 133 to open or close the diaphragm 148. If the diaphragm 148 were also fashioned as a threshold valve as previously described, the need for the valves 108 or 111 could be eliminated.

[0139] The housing 132 can conveniently be constructed in several parts which are connected together at various connection points. In this manner, the housing can be taken apart for connection to other devices, for repair, for cleaning, and the like. For example, one connection point can be conveniently provided near the filter 158 for removably connecting the portion of the housing having the intake opening 134, the valve 140, and the exhaust opening 136. Alternatively, a connection point can be provided near the mount 150 to provide easy access to the mount 150 for cleaning.

[0140] The valving system 130 can conveniently be incorporated with a variety of devices useful in CPR procedures. For example, the valving system 130 can be incorporated within a respiratory bag, such as an AMBU bag. Alternatively, the valving system 130 can be included as part of a respiratory circuit having both a respiratory bag and an endotracheal tube or other airway tube, with the valving system 130 positioned between the bag and the tube. In further alternative, the valving system 130 can be added to an endotracheal tube alone. Alternatively, the valving system can be incorporated into a mask, an oralpharyngeal airway, a laryngeal mask or other ventilatory devices.

[0141] In some cases, patient ventilation may be provided through threshold valve 160 as shown in FIG. 16D. In such a case, intake opening and valve 140 are optional since all ventilation may occur through threshold valve 160. Of course, ventilation could be provided through both avenues. Further, although shown in the context of valving system 130, it will be appreciated that the other embodiments described herein may be modified to include a pressure source that is coupled to the threshold valve.

[0142] As shown in FIG. 16D, a tank 300 of pressurized gas, such as O₂, is coupled to housing 132 by a length of tubing 302. In this way, a pressurized gas may be supplied to the back side of threshold valve 160. A regulator 304 is coupled to tank 300 to regulate the pressure supplied to threshold valve 160 so that it is less than the pressure required to open valve 160. For example, if respiratory gases are to be supplied to the patient when the negative intrathoracic pressure exceeds -14 cm H₂O, then the actuating valve pressure may be set at -14 cm H₂O, and the pressure of the gas from tank 300 may be set less than -14 cm H₂O. In this

way, valve **160** will not prematurely open. In some cases, regulator **304** may also be used to regulate the flow rate of the gas through valve **160**.

[**0143**] By coupling tank **300** to valve **160**, respiratory gases are pulled into downstream region **144** when valve **160** opens due to the decrease in negative intrathoracic pressure as previously described. In this way, more respiratory gases are supplied to the patient each time the patient's chest is decompressed. This approach allows for negative pressure ventilation, unlike positive pressure ventilation which impedes venous return to the chest with each active rescuer ventilation. The negative pressure ventilation with this approach allows for adequate oxygenation and maximum venous blood return during CPR. Tank **300** may also function to provide oxygen once the trigger pressure has been achieved.

[**0144**] Referring to **FIG. 17**, an alternative valving system **164** will be described. The valving system **164** is shown schematically and operates essentially identical to the valving system **100**, the difference being that the valving system **164** includes a ball or spherical member **166** as the diaphragm. During decompression of the patient's chest, the pressure in a downstream region **168** is less than the pressure in an upstream region **170** which draws the ball **166** over the downstream region **168**. The valving system **164** can optionally be provided with a spring **172** or other biasing mechanism to hold the ball **166** over the downstream region **168** during compression of the patient's chest until a threshold pressure is reached or exceeded in the downstream region **168** as previously described.

[**0145**] Referring now to **FIG. 18**, another exemplary device **200** which is useful when performing cardiopulmonary resuscitation will be described. As described in greater detail hereinafter, one important feature of device **200** is that it may be interfaced to the patient's airway to periodically supply air to the patient's lungs when performing cardiopulmonary resuscitation. In this way, the patient may be ventilated with air (or other desired gases, such as O₂) rather than with respiratory gases from the rescuer's lungs as is typically the case when performing mouth-to-mouth resuscitation.

[**0146**] Device **200** comprises a facial mask **202** and a housing **204** that is operably attached to facial mask **202** at an interface **206**. Housing **204** includes an upper region **208** and a lower region **210**. Lower region **210** includes a pressure responsive valving system **212** which operates in a manner similar to the embodiments previously described herein to prevent the flow of gases into the patient's lungs until a threshold negative intrathoracic pressure is exceeded. At this point, pressure responsive valving system **212** allows gases to flow into the patient's lungs in a manner similar to that previously described herein. Lower region **210** further includes a fish mouth valve **214** and one-way outflow valves **216**. Valves **214** and **216** operate together to allow gases exhausted from the patient's lungs to exit device **200** as indicated by arrow **218**. In particular, when gases are forced out of the patient's lungs, fish mouth valve **214** will be closed and the exhausted gases will escape from device **200** through valves **216**.

[**0147**] Upper region **208** includes a mouth piece **219** to allow a rescuer to blow into device **200** when attempting to ventilate a patient (similar to conventional CPR). Upper

region **208** defines an air chamber **220** for holding room air and has a volume of about 200 ml to about 800 ml. Chamber **200** may also be connected to an oxygen source. Disposed within upper region **208** is a diaphragm **222** and a spring **224**. With this configuration, when a rescuer blows air into mouth piece **219**, spring **224** will compress as diaphragm **222** moves downward. In turn, air or oxygen held within air chamber **220** will be compressed and hence forced through valving system **212** and into facial mask **202**. In this way, air (rather than respiratory gases) from the rescuer will be supplied to the patient when the rescuer performs mouth-to-mouth resuscitation by blowing into mouth piece **219**.

[**0148**] Upper region **208** further includes a one-way inflow valve **226** which allows air chamber **220** to be replenished with room air following ventilation. In particular, as spring **224** expands valve **226** will open to allow room air to fill chamber **230** due to the negative pressure created in chamber **230** by spring **224**. Inflow valve **226** will also open when the threshold negative intrathoracic pressure is exceeded causing pressure responsive valving system **212** to open. In this way, inflow valve **226** also serves as a venting mechanism to vent air into housing **204** when the negative intrathoracic pressure limit is exceeded.

[**0149**] Hence, device **200** allows a rescuer to ventilate a patient with room air simply by blowing into mouth piece **219**. Of course, it will be appreciated that other desirable gases may be placed within air chamber **220** so that such gases may be supplied to the patient when the rescuer blows into mouth piece **219**. For example, a volume of **02** may be placed within chamber **220**.

[**0150**] As previously described, one aspect of the invention is the ability to prevent respiratory gasses from entering the lungs until a certain negative intrathoracic pressure is met or exceeded. One aspect of the invention is the ability to vary the pressure at which respiratory gasses are permitted to flow to the lungs. In some cases, this may be accomplished by varying the actuating or cracking pressure of the pressure-responsive inflow valve. However, other mechanisms may be provided to vary the pressure at which respiratory gasses are permitted to flow to the lungs without modifying the cracking pressure of the pressure-responsive inflow valve. Hence, mechanisms for varying the pressure at which respiratory gasses are permitted to flow to the lungs may be incorporated in the pressure-responsive inflow valve, another valve in the valving system, or may be a separate part of the overall valving system.

[**0151**] Such a system may be configured so that the actuating pressure may vary between about 0 cm H₂O to about -30 cm H₂O. Further, such a valving system may be used alone with a spontaneous breathing patient or with a patient receiving standard manual closed-chest CPR. Such a valving system may also be used in conjunction with other resuscitation techniques and/or devices, including, for example, ACD CPR, Vest CPR, or the like. In some cases, such a valving system may be used in connection with a diaphragmatic stimulator for purposes of resuscitation from cardiac arrest as well as for increasing blood pressure by advancing venous return. Exemplary systems and techniques for diaphragmatic stimulation for purposes of resuscitation are described in U.S. patent application Nos. 09/095,916, filed Jun. 11, 1998; 09/197,286, filed Nov. 20, 1998; 09/315,396, filed May 20, 1999; and 09/533,880, filed Mar.

22, 2000, incorporated herein by reference. As a further example, such a valving system may be used to improve central blood return to the heart in patients in cardiac arrest, patients with low blood pressure and patients in right heart failure and in shock.

[0152] A variety of mechanisms may be used to vary the degree at which respiratory gasses are permitted to flow to the lungs. For example, such a mechanism may be mechanical or electronic or may include various combinations of mechanical and electronic components, and may be regulated within a larger system by, for example, electronic communication between the device used for resuscitation and the pressure-responsive inflow valve. Such a mechanism may also be adjustable based upon the in-line measurement of gasses, such as the measurement of end-tidal CO₂, the average minute ventilations, peak negative inspiratory pressures, and the like.

[0153] Referring to FIG. 19, one embodiment of a valving system 400 having an adjustable pressure-responsive inflow valve 402 will be described. Valving system 400 is shown schematically and may be constructed similar to any of the embodiments described herein. As such, when valving system 400 is interfaced with a patient's airway, the patient may freely exhale through valving system 400. When attempting to inhale, or during a decompression step of CPR, respiratory gasses are prevented from entering the lungs until a threshold actuating pressure is reached. At such time, respiratory gasses are permitted to flow to the lungs through inflow valve 402 in a manner similar to that previously described with other embodiments.

[0154] Inflow valve 402 includes a tension adjust knob 404 that may be turned by the rescuer to adjust the threshold actuating pressure of inflow valve 402 and will be described in greater detail with reference to FIGS. 20-22. As best shown in FIG. 20, inflow valve 402 comprises an outer housing 406 having a set of tracking channels 408 (see FIG. 22). Outer housing 406 is configured to hold an O-ring housing 410 having a top segment 412 and a bottom segment 414. Disposed between top segment 412 and bottom segment 414 is an O-ring 416. Top segment 412 further includes a set of tracking rails 418 that slide within tracking channels 408. A tension spring 420 sits between tension adjust knob 404 and top segment 412 and biases O-ring 416 against outer housing 406. When O-ring 416 is biased against outer housing 406 the valve is in the closed position where respiratory gasses are prevented from passing through ventilation ports 422 and to the patient's lungs. When the negative intrathoracic pressure meets or exceeds the threshold actuating pressure of inflow valve 402, the tension in spring 420 is overcome, causing O-ring 416 to separate from outer housing 406. At this point, respiratory gasses are free to rush through ventilation ports 422 and to the patient's lungs.

[0155] To vary the actuating pressure of inflow valve 402, knob 404 is turned to advance or retract a threaded nut 424 along a threaded bolt 426 that in turn is coupled to top segment 412. In so doing, the tension of spring 420 is varied to vary the actuating pressure of inflow valve 402. Hence, knob 404 provides a convenient way for a rescuer to adjust the actuating pressure simply by turning knob 404. Although not shown, a pressure gauge may be disposed within valving system 400 and a display may be provided to display the

negative intrathoracic pressure. In this way, the rescuer may readily visualize the pressures generated within valving system 400 and may adjust knob 404 to vary the pressure at which respiratory gasses are permitted to flow to the lungs.

[0156] Another feature of the invention is the use of a safety mechanism to permit respiratory gasses to freely flow to the patient through the valving system until the rescuer places the valving system in an operative mode. Once in the operative mode, the valving system will remain in that mode indefinitely or for a finite period of time, at which the safety mechanism would revert back to its initial state where respiratory gasses may freely flow to the lungs. In some embodiments, this may be accomplished by having the safety mechanism maintain the pressure responsive inflow valve in the open position (without any impedance to inspiratory air flow) until actuated by the rescuer. Actuation may be accomplished in a variety of ways, such as by injected respiratory gasses into the valving system (such as when ventilating the patient), by operating a button or switch on the valving system, or the like.

[0157] One advantage of such a safety mechanism is that it ensures that the patient can freely breathe through the valving system (assuming the patient is spontaneously breathing or begins to spontaneously breathe) without any resistance from the pressure responsive inflow valve. Once the rescuer is ready to begin a procedure, such as performing CPR, the valving system is placed in the operative mode where respiratory gas flow to the lungs is prevented through the pressure-responsive inflow valve until the threshold negative intrathoracic pressure is met or exceeded. As with other embodiments described herein, respiratory gasses may also be injected into the patient's lungs through the valving system, thereby bypassing the pressure-responsive inflow valve.

[0158] The safety mechanism may operate as a purely mechanical device, a purely electronic device, or may include various combinations of mechanical and electronic components. One way for placing the valving system in the operative mode is by utilizing a sensor to detect when respiratory gasses are injected into the valving system through the ventilator port. The signal from the sensor may then be used to close a ventilation passage within the valving system. In some cases, the ventilation passage may extend through the pressure-responsive inflow valve. To close this passage, the inflow valve is simply closed. In some embodiments, if rescuer ventilation is not provided within a certain time, the safety mechanism may be used to take the valving system out of its operative mode so that respiratory gasses may freely flow to the patient's lungs.

[0159] Referring now to FIGS. 23 and 24, one embodiment of a valving system 430 with such a safety feature will be described. This configuration may be used in series with any of the previously described valving systems so that it will have a means of impeding airflow to the patient's lungs. Hence, it will be appreciated that valving system 430 may be constructed to have, or used in combination with, components similar to the other valving systems described herein and will not be illustrated to simplify discussion. Valving system 430 includes a housing 432 that may be similar to the housings of the other valving systems described herein except that housing 432 includes a safety ventilation port 434 that permits respiratory gasses to flow into and through

housing 432 so that respiratory gasses may flow to the patient's lungs as shown by the dashed line in FIG. 23. Hence, as shown in FIG. 23, valving system 430 is in a passive mode where the patient may freely breathe through housing 432.

[0160] Valving system 430 further includes a safety mechanism 436 that is operative to maintain ventilation port 434 open until actuated by a rescuer. When actuated, safety mechanism 436 closes ventilation port 434 to place valving system 430 in the operative mode where respiratory gasses are prevented from reaching the lungs through a pressure-responsive inflow valve until a threshold negative intrathoracic pressure is met or exceeded in a manner similar to that described in other embodiments.

[0161] Safety mechanism 436 comprises an electronic air flow sensor 438 that is electrically connected to control circuitry 440. In turn, control circuitry 440 is electrically connected to a micro-solenoid 442 having a valve stop 444. A battery 445 is used to supply power to the electrical components. When a rescuer is ready to place valving system 430 in the operative mode, the rescuer injects respiratory gasses into housing 432 (such as by blowing air or injecting a pressurized gas into a ventilation port, not shown). As the respiratory gasses flow to the patient's lungs through housing 432, sensor 438 is moved to trigger a switch and to send an electrical signal to control circuitry 440. Control circuitry 440 then sends a signal to solenoid 442 to move stop 444 and thereby close the valve, thus preventing airflow to the patient through safety ventilation port 434. Such a state is illustrated in FIG. 24 where valving system 430 is in the operative mode. At this point, a spontaneously breathing patient will need to breathe through a pressure-responsive inflow valve. For a non-breathing patient, respiratory gasses will be prevented from reaching the lungs during the performance of CPR until a threshold negative intrathoracic pressure is overcome, at which point respiratory gasses may flow through the inflow valve and to the patient's lungs in a manner similar to that described with other embodiments. If, after a certain time, sensor 438 is not actuated by the rescuer, control circuitry 440 may be configured to operate solenoid 442 to take valving system 430 out of the operative mode where respiratory gasses may flow through safety ventilation port 434.

[0162] In some embodiments, the valving systems of the invention may incorporate a safety mechanism having essentially all mechanical elements. One such embodiment of a valving system 480 is illustrated in FIGS. 25 through 33 and 36 through 40. Valving system 480 comprises a housing 482 that houses various components that may be similar to the other embodiments described herein. As such, housing 482 includes a ventilation port 484 and an exit opening 486. Valving system 480 further includes a pressure-responsive inflow valve 488 that prevents respiratory gasses from flowing to the patient's lungs until a certain negative intrathoracic pressure level has been met or exceeded in a manner similar to that described with other embodiments. Valving system 480 further includes a safety mechanism 490 to permit respiratory gasses to freely flow to the patient's lungs until operated to place valving system 480 in an operative mode where pressure-responsive inflow valve 488 controls when respiratory gasses are permitted to flow to the lungs. As described in greater detail hereinafter, safety mechanism 490 also includes an inflow valve 492. In

some embodiments, inflow valve 492 may be configured as a pressure-responsive inflow valve and thereby eliminate the need for inflow valve 488.

[0163] Safety mechanism 490 further comprises a flow sensor 494 that is in the form of a flap. Flow sensor 494 pivots about a pivot point 496 to move a cam mechanism 498, thereby rotating a wheel 500. In FIGS. 25 and 30, valving system 480 is in the inactive state where flow sensor 494 has not yet been activated. When respiratory gasses are directed through housing 482, flow sensor 494 pivots about pivot point 496 as previously described to rotate wheel 500 as illustrated in FIGS. 27, 28 and 30.

[0164] As best shown in FIG. 29, wheel 500 is connected to a gear system 502 having a recoil spring 504 and a valve cam 506. Recoil spring 504 is employed to bias cam 506 in the position illustrated in FIGS. 25 and 30 where valve 492 is in the open position. When gasses flow through housing 482, flow sensor 494 is moved to cause wheel 500 to rotate and thereby operate gear system 502. In so doing, cam 506 is rotated to the position shown in FIGS. 27 and 31 where valve 492 moves to the closed position. Gear system 502 and recoil spring 504 operate to open valve 492 after a certain period of time has elapsed, such as about 10 to 20 seconds.

[0165] As best shown in FIGS. 30 and 31, valve 492 comprises a valve housing 508 in which is held a valve shaft 510 that holds an O-ring 512. A tension spring 514 is positioned between housing 508 and a projection 516 on shaft 510 to bias the valve 492 in the closed position as illustrated in FIG. 31. When a rescuer injects respiratory gasses into the housing of the valving system, cam 506 moves to the position shown in FIG. 30 where it engages shaft 510 and disengages O-ring 512 from housing 508 to place valve 492 in the open position. In the open position, respiratory gasses are free to flow through valve 492 and into housing 482 where they may flow to the patient's lungs through exit opening 486.

[0166] The invention further provides systems having safety features that allow for the patient to inhale to a given degree to release the mechanism that is used to impede or prevent respiratory gases from flowing to the lungs, thereby allowing for resistance free inspiration until a timer resets the systems or until the rescuer resets the system. One embodiment of a safety valve 600 that may be used with such systems is illustrated in FIGS. 32 and 33. Safety valve 600 may be used as a replacement for any of the pressure responsive valves described herein, such as, for example, valves 108, 160 and 111. Valve 600 comprises a housing 602 which is covered by a slit membrane 604. A valve member 606 is biased by a spring 608 into a closed position as shown in FIG. 32. In the closed position, a wedge 610, that may conveniently be colored for easy identification, extends above the slit in membrane 604. As such, wedge 610 serves as a visual indicator to the rescuer that valve 600 is in the closed position. When interfaced with a patient and in the closed position, respiratory gases may be prevented from flowing to the lungs until the negative intrathoracic pressure meets or exceeds a threshold value in a manner similar to that described with other embodiments. At such time, a seal 612 on valve member 606 moves away from a stop 614 on housing 602 to permit respiratory gases to flow to the lungs. Spring 608 then forces valve member 606 back to the closed position.

[0167] If the patient gasps and begins to breathe, the amount of negative pressure created by the patient compresses spring 608 far enough so that wedge 610 is pulled through the slit in membrane 604 as shown in FIG. 33. Wedge 610 then holds valve 600 in the open position where gases may freely flow to the lungs. The rescuer may easily determine valve 600 is in the open position by noticing that wedge 610 is no longer visible. The rescuer may reset valve 600 at any time by simply pulling on a pull tab 616 to pull wedge 610 back through membrane 604.

[0168] Another embodiment of a safety valve 620 that may be used in the systems described herein is illustrated in FIGS. 34 and 35. Valve 620 comprises a housing 622 having a stop 624. A micro-solenoid 626 is disposed within housing 622 and includes an arm 628 having a pole magnet 629 and a visual indicator 630 at an opposite end. Spaced apart from pole magnet 629 is another pole magnet 632 of opposite polarity that is coupled to a valve member 634 having a seal 636. Coupled to housing 622 is a normally open contact strip switch 638, and valve member 634 includes a conductive strip 640. A spring 642 is disposed between strip 640 and stop 624.

[0169] FIG. 34 illustrates valve 620 in the closed or active position. During CPR, seal 636 will separate from stop 624 to permit respiratory gases to flow to the lungs when the negative intrathoracic pressure exceeds a threshold value. Valve 620 then returns back to the closed position. If the patient gasps, valve member 634 moves to the position shown in FIG. 35 where conductive strip 640 contacts switch 638. (During normal CPR, valve member 634 is not moved far enough for this contact to occur). This closes the open circuit and activates solenoid 626 to extend arm 628 and trigger a timing circuit within a control circuitry and battery compartment 644. Magnets 629 and 632 have opposite poles causing valve to remain in the open and inactive position as shown in FIG. 35 as long as solenoid 626 is actuated. In this way, the patient may continue to freely breathe through valve 620. Although shown with opposing pole magnets, it will be appreciated that magnets may be substituted with a solenoid arm that may act as a plunger to make physical contact with valve member 634, and thus hold the valve open and inactive. The rescuer may note that valve 620 is in the open position by noting that indicator 630 has been retracted and is no longer visible.

[0170] Valve 620 may include an auto/manual switch 646 that may be set in automatic mode. In this mode, the timing circuit automatically deactivates solenoid 626 and returns valve 620 back to the closed and active position shown in FIG. 34 after a preset timing interval has expired. If switch 646 is set to manual, solenoid 626 remains active and valve 620 remains open and inactive as shown in FIG. 35 where respiratory gases may freely flow to the lungs. Valve 620 remains open until the rescuer manually resets solenoid 626 by pressuring a manual reset switch 648. The rescuer may note that valve 620 is closed and active by observing indicator 630 that is now extended.

[0171] FIGS. 36 and 37 illustrate a further embodiment of a safety valve 650 that may be used with the systems described herein. Valve 650 comprises a housing 652 having a stop 654. Disposed within housing 652 is a valve member 656 having a seal 658 that contacts stop 654 to prevent gases from flowing through valve 650 when in the closed or active

position shown in FIG. 36. In the closed position, a spring 660 biases seal 658 against stop 654 until the negative intrathoracic pressure exceeds a threshold value and seal 658 moves away from stop 654 to permit respiratory gases to flow to the lungs. Once the negative intrathoracic pressure falls below the threshold value, valve 650 moves back to the closed position.

[0172] When the patient gasps, the force created is great enough to move valve member 656 such that a pair of spring loaded pins 662 lodge within grooves 664 of a locking pin receptacle 666 on valve member 656 as shown in FIG. 37. In this way, valve 650 is locked into an open or inactive position that is created by the patient's gasp. As pins 662 move into grooves 664, the ends of pins 662 move into housing 652 to indicate to the rescuer that the valve is inactive. Conveniently, the ends of pins 662 may be colored to make them more visible to the rescuer. To reactivate valve 650, the rescuer may pull upward on a pull tab 668 on valve member 656. This releases pins 662 from grooves 664 and permit the valve to spring back to the closed position of FIG. 36.

[0173] Referring now to FIGS. 38-40, a modified version valve 650 is shown incorporated into a valve system 670 that may be coupled to a patient's airway in a manner similar to the other valve system embodiments described herein to regulate the airflow to the patient's lungs during a CPR procedure. For convenience of discussion, identical elements of valve 650 will use the same reference numerals in describing FIGS. 38-40. The use of valve 650 allows the patient to gasp and breathe free of airway resistance after the initial gasp has occurred. Alternatively, valve 650 may be initially set in the inactive position and placed in the active state upon the initial ventilation through valve system 670, or upon subsequent ventilations if the patient gasps and locks valve 650 open and inactive.

[0174] Valve 650 is incorporated into a system housing 672 having an inlet end 674 and an outlet end 676. Conveniently, patient ventilation may occur through inlet end 674 using a ventilatory source similar to other embodiments. Outlet end 676 may be coupled to an interface that permits system 670 to be interfaced with the patient's airway. Disposed within housing 672 is a one way membrane valve 678 that is spaced apart from port 680. In FIG. 38, system 670 is in the resting state where no gasp or ventilation has occurred. When performing CPR, the chest is compressed and air forced from the patient is permitted to flow through port 680 and through valve 678. During decompression of the patient's chest, valve membrane 678 moves against port 680 to close the valve as the negative intrathoracic pressure is increased. If a threshold pressure is overcome, valve 650 opens to permit respiratory gases to flow through opening 676 after passing through valve 650. Valve 650 then moves back to the closed position and the cycle is repeated. If valve system 670 is coupled to a patient's airway and the patient gasps or begins spontaneously breathing, valve system 670 automatically adjusts to the configuration shown in FIG. 39 so that the patient may breathe through a resistance free airway path so that respiratory gas exchange may occur. When the patient gasps or begins to breathe, valve 678 closes and the negative pressure causes valve 650 to open and lock in place in a manner similar to that previously

described in connection with FIG. 37. In this way, valve 650 remains open and inactive until reset by the rescuer by pulling on pull tab 668.

[0175] Another way to place valve 650 back into the closed or active position is by ventilating the patient through inlet 674 as shown in FIG. 40. When injecting a respiratory gas into inlet 674, the injected gases flow through valve 678 and through port 680 where the exit through outlet 676 and to the patient. In so doing, the flow of gases moves a ventilation flap 682 that in turn moves an arm 684 that is coupled to a wedge 686. Movement of wedge 686 causes lateral movement of an arm 688 that is connected to a reset wedge 690. Wedge 690 rests on top of an upward movement ramp 692. As arm 688 is laterally moved, wedge 690 moves up ramp 692 and contacts pull tab 668. In so doing, valve member 656 is pulled up until pins 662 are pulled from grooves 664 and valve 650 moves back to the closed and active position by force of spring 660. A reset spring 694 then resets ventilation flap 682 back to its home position and wedge 690 slides back down ramp 692 so that valve 650 may be reset back to the closed position if subsequently needed. Valve 650 remains in the closed and active position until another gasp or spontaneous breathing occurs.

[0176] FIG. 41 schematically illustrates another embodiment of a valving system 700 that is configured to display the pressure within the patient's chest during CPR. Valving system 700 may be configured to be similar to any of the valving systems described herein. Hence, for convenience of discussion, valving system 700 will only be briefly described. Valving system 700 comprises a housing 702 having an inlet 704 and an outlet 706. A pressure responsive valve 708 is used to control the inflow of gases into housing 702 during decompression of the patient's chest in a manner similar to that described with other embodiments. A pressure gauge 710 is provided to measure and display the pressure within housing 702 which corresponds to the pressure within the patient's chest. In this way, pressure gauge 710 may be used to provide immediate feedback to the rescuer and may be used as a guide to determine if chest compressions and/or decompressions are being appropriately performed.

[0177] A pressure sensing port 712 is connected to a tube 714 that is connected to a pressure sensing control unit 716. In this manner, a change in pressure may be detected during either chest compressions or decompressions and act as a counting circuit to trigger ventilation control circuitry 718 to automatically ventilate the patient using a ventilator 720 after a certain number have been detected.

[0178] Alternatively, a digital control unit may be used that displays the pressure within the chest as well as the number of compressions between ventilations. With such a configuration, pressure sensing port 712 transmits pneumatically the pressure information. As such, a pressure gauge on housing 702 would not be required.

[0179] Although the foregoing invention has been described in some detail by way of illustration and example, for purposes of clarity of understanding, it will be obvious that certain changes and modifications may be practiced within the scope of the appended claims.

What is claimed is:

1. A method for increasing cardiopulmonary circulation induced by chest compression and decompression when

performing cardiopulmonary resuscitation, by augmenting negative intrathoracic pressures, said method comprising the steps of:

interfacing a pressure responsive inflow valve to a patient's airway;

performing chest compression and chest decompression, wherein during chest decompression the inflow valve prevents respiratory gases from entering the lungs until a negative intrathoracic pressure level in the range from about -3 cm H_2O to -30 cm H_2O is exceeded at which time the inflow valve opens, said inflow valve assisting in increasing the magnitude and duration of negative intrathoracic pressure during decompression and thereby enhancing the amount of blood flow into the heart and lungs; and

supplying the patient with a pressurized respiratory gas through the inflow valve when the inflow valve opens to ventilate the patient.

2. The method of claim 1, further comprising interfacing an exhalation valve to the patient's airway, wherein the exhalation valve prevents air from leaving the lungs until a positive intrathoracic pressure threshold is exceeded at which time said exhalation valve opens, said exhalation valve assisting in forcing more blood out of the thorax.

3. The method of claim 2, wherein the positive intrathoracic pressure is in the range from about 2 cm H_2O to 20 cm H_2O .

4. The method of claim 1, further comprising providing a pressurized respiratory gas source that is operably coupled to the inflow valve, with the respiratory gas being at a pressure that is less than the opening pressure of the inflow valve, and wherein the respiratory gas is supplied from the respiratory gas source.

5. The method of claim 1, wherein the decompressing step comprises allowing the patient's chest to expand in response to the chest's resilience.

6. The method of claim 1, wherein the decompressing step comprises lifting or actively expanding the patient's chest to expand the thorax.

7. The method of claim 1, wherein the chest is compressed in the range from about 3.5 cm to 5 cm per compression, and wherein the chest is compressed in the rate from 60 to 100 per minute.

8. A method for increasing cardiopulmonary circulation induced by chest compression and decompression when performing cardiopulmonary resuscitation, by augmenting negative intrathoracic pressures, said method comprising the steps of:

interfacing a valving system with a patient's airway, the valving system comprising a housing having an upstream region and a downstream region, a pressure responsive valve between the upstream region and the downstream region for preventing respiratory gases from flowing from the upstream region to the downstream region until the pressure in the downstream region falls below a threshold level;

performing chest compression and decompression, wherein said pressure responsive valve is closed to prevent respiratory gases from entering the lungs until a certain negative intrathoracic pressure is exceeded at which time the pressure-responsive valve opens, said pressure-responsive valve assisting in increasing the

magnitude and duration of negative intrathoracic pressure during decompression and thereby enhancing the amount of blood flow into the heart and lungs; and

supplying the patient with a pressurized respiratory gas through the pressure-responsive valve when the pressure-responsive valve opens to ventilate the patient.

9. The method of claim 8, further comprising, during chest compression, preventing air from leaving the lungs until a positive intrathoracic pressure threshold is exceeded to assist in forcing more blood out of the thorax.

10. The method of claim 9, wherein the positive intrathoracic pressure is in the range from about 2 cm H₂O to 20 cm H₂O.

11. The method of claim 8, further comprising providing a pressurized respiratory gas source that is operably coupled to the pressure-responsive valve, with the respiratory gas being at a pressure that is less than the opening pressure of the pressure responsive valve and wherein the respiratory gas is supplied from the respiratory gas source.

12. The method of claim 8, wherein the decompressing step comprises allowing the patient's chest to expand in response to the chest's resilience.

13. The method of claim 8, wherein the decompressing step comprises lifting or actively expanding the patient's chest to expand the thorax.

14. The method of claim 8, wherein the chest is compressed in the range from about 3.5 cm to 5 cm per compression, and wherein the chest is compressed in the rate from 60 to 100 per minute.

15. A device for increasing cardiopulmonary circulation induced by chest compression and decompression when performing cardiopulmonary resuscitation, said device comprising:

a housing having an opening that is adapted to be interfaced with a patient's airway;

a pressure responsive inflow flow valve which prevents respiratory gases from entering the lungs through the housing until a threshold negative intrathoracic pressure level is exceeded during decompression of the patient's chest at which time the inflow valve opens, the inflow valve assisting in increasing the magnitude and duration of negative intrathoracic pressure during decompression and thereby enhancing the amount of blood flow into the heart and lungs; and

a source of pressurized gas operably coupled to the inflow valve to supply a pressurized gas to the patient through the housing when the inflow valve is open.

16. A device as in claim 15, further comprising a one way valve disposed in the housing to permit respiratory gases to exit the housing during compression of the patient's chest.

17. A device as in claim 15, further comprising a regulator disposed between the gas source and the inflow valve to regulate the pressure of the gas such that the gas pressure is less than the actuating pressure of the inflow valve.

18. A device as in claim 15, wherein the inflow valve is configured to open when the negative intrathoracic pressure is in the range from -3 cm H₂O to -30 cm H₂O.

19. A method for increasing cardiopulmonary circulation induced by chest compression and decompression when performing cardiopulmonary resuscitation, by augmenting negative intrathoracic pressures, said method comprising the steps of:

interfacing a housing having a pressure responsive inflow valve to a patient's airway;

performing chest compression and chest decompression, wherein during chest decompression, the inflow valve prevents respiratory gases from entering the lungs until a threshold negative intrathoracic pressure level is exceeded at which time the one inflow valve opens, the inflow valve assisting in increasing the magnitude and duration of negative intrathoracic pressure during decompression and thereby enhancing the amount of blood flow into the heart and lungs; and

supplying a pressurized gas to the patient through the inflow valve when the inflow valve opens to ventilate the patient through the inflow valve.

20. A method as in claim 19, wherein the inflow valve opens when the negative intrathoracic pressure in the range from -3 cm H₂O to -30 cm H₂O, and wherein the pressurized gas is less than the opening pressure of the inflow valve.

21. A device for increasing cardiopulmonary circulation induced by chest compression and decompression when performing cardiopulmonary resuscitation, said device comprising:

a housing having an opening that is adapted to be interfaced with a patient's airway;

a pressure responsive inflow flow valve which prevents respiratory gases from entering the lungs through the housing until a threshold negative intrathoracic pressure level is exceeded during decompression of the patient's chest at which time an actuating pressure of the inflow valve is exceeded and the inflow valve opens, the inflow valve assisting in increasing the magnitude and duration of negative intrathoracic pressure during decompression and thereby enhancing the amount of blood flow into the heart and lungs; and

a mechanism for varying the actuating pressure of the inflow valve.

22. A device as in claim 21, wherein the mechanism is configured to vary the actuating pressure to a pressure within the range from about 0 cm H₂O to about -30 cm H₂O.

23. A device as in claim 21, wherein the inflow valve comprises a threaded shaft having a seal that is configured to block an opening in the housing, and a spring that biases the seal against the housing, and wherein the mechanism comprises a threaded knob that is rotatable to vary the biasing force of the spring by increasing or decreasing the longitudinal distance of the shaft.

24. A device as in claim 23, further comprising a pressure gauge in the housing to sense the amount of pressure within the chest.

25. A device for increasing cardiopulmonary circulation induced by chest compression and decompression when performing cardiopulmonary resuscitation, said device comprising:

a housing having an exit opening that is adapted to be interfaced with a patient's airway and a safety ventilation passageway;

a pressure responsive inflow flow valve which prevents respiratory gases from entering the lungs through the housing until a threshold negative intrathoracic pressure level is exceeded during decompression of the

patient's chest at which time the inflow valve opens, the inflow valve assisting in increasing the magnitude and duration of negative intrathoracic pressure during decompression and thereby enhancing the amount of blood flow into the heart and lungs; and

a safety mechanism to maintain the safety ventilation passageway open to permit respiratory gases to freely flow to the patient's lungs until actuated by a rescuer to close the safety ventilation passageway.

26. A device as in claim 25, wherein the safety ventilation passageway is provided through the inflow valve when the inflow valve is in an open position, and wherein the safety mechanism is configured to maintain the inflow valve in the open position until actuated by the rescuer to move the inflow valve to a closed position.

27. A device as in claim 26, wherein the housing includes a ventilation port to permit respiratory gases to be injected into the housing, and wherein the safety mechanism comprises a sensor to sense when the rescuer injects respiratory gases into the housing and a control system to move the inflow valve from the open position to the closed position.

28. A device as in claim 27, wherein the sensor is movable upon injection of respiratory gases into the housing, and wherein control system comprises a set of gears that are coupled to the sensor and a cam that is movable by the gears to close the inflow valve.

29. A device as in claim 27, wherein the sensor comprises a movable flap that moves upon injection of respiratory gases into the housing, and wherein control system comprises a set of mechanical components that move a wedge against the safety mechanism upon movement of the flap to close the inflow valve.

29. A device as in claim 27, wherein the sensor is selected from a group of sensors consisting of electronic switches, thermistors, mechanical flaps, and materials that experience of change of resistance when flexed.

30. A device as in claim 26, wherein the inflow valve comprises a shaft having a seal that is configured to block an opening in the housing, and a spring that biases the seal against the housing.

31. A device for increasing cardiopulmonary circulation induced by chest compression and decompression when performing cardiopulmonary resuscitation, said device comprising:

a housing having an opening that is adapted to be interfaced with a patient's airway;

a pressure responsive inflow flow valve having a closed position and an open position, wherein the inflow valve prevents respiratory gases from entering the lungs through the housing when in the closed position, and wherein the inflow valve moves to the open position when a threshold negative intrathoracic pressure level is exceeded during decompression of the patient's chest, the inflow valve assisting in increasing the magnitude and duration of negative intrathoracic pressure during decompression when in the closed position and thereby enhancing the amount of blood flow into the heart and lungs; and

a safety mechanism to maintain the inflow valve in the open position to permit respiratory gases to freely flow to the lungs until actuated by a rescuer to place the inflow valve in the closed position.

32. A device as in claim 31, wherein the housing includes a ventilation port to permit respiratory gases to be injected into the housing, and wherein the safety mechanism comprises a sensor to sense when the rescuer injections respiratory gases into the housing and a control system to move the inflow valve from the open position to the closed position.

33. A device as in claim 32, wherein the sensor is movable upon injection of respiratory gases into the housing, and wherein control system comprises a set of gears that are coupled to the sensor and a cam that is movable by the gears to close the inflow valve.

34. A device as in claim 32, wherein the sensor comprises a movable flap that moves upon injection of respiratory gases into the housing, and wherein control system comprises a set of mechanical components that move a wedge against the safety mechanism upon movement of the flap to close the inflow valve.

35. A device as in claim 32, wherein the sensor is selected from a group of sensors consisting of electronic switches, thermistors, mechanical flaps, and materials that experience of change of resistance when flexed.

36. A device as in claim 31, wherein the inflow valve comprises a shaft having a seal that is configured to block an opening in the housing, and a spring that biases the seal against the housing.

37. A method for increasing cardiopulmonary circulation induced by chest compression and decompression when performing cardiopulmonary resuscitation, by augmenting negative intrathoracic pressures, said method comprising the steps of:

interfacing a valve system comprising a housing, a pressure responsive inflow valve, a safety gas flow passage and a safety mechanism to a patient's airway, wherein during chest decompression the inflow valve is configured to prevent respiratory gases from entering the lungs until a negative intrathoracic pressure level in the range from about 0 cm H₂O to -30 cm H₂O is exceeded at which time the inflow valve is configured to open, said inflow valve assisting in increasing the magnitude and duration of negative intrathoracic pressure during decompression and thereby enhancing the amount of blood flow into the heart and lungs, and wherein the safety mechanism is configured to permit respiratory gases to freely flow to the patient's lungs until actuated; and

actuating the safety mechanism to close the gas passage.

38. A method as in claim 37, further comprising performing chest compressions and decompressions after actuating the safety mechanism.

39. A method as in claim 37, wherein the actuating step comprises injecting a respiratory gas into the housing, wherein the injection is sensed by a sensor to cause the safety mechanism to close the gas passage.

40. A method as in claim 37, wherein the gas passage passes through the inflow valve, and wherein the actuating step comprises closing the inflow valve to close the gas passage.

41. A method for increasing the blood pressure in a spontaneously breathing person, said method comprising the steps of:

interfacing a pressure responsive inflow valve to the person's airway;

inhaling and exhaling while the inflow valve is coupled to the person's airway,

wherein during inhalation the inflow valve prevents respiratory gases from entering the lungs until a negative intrathoracic pressure level in the range from about 0 cm H₂O to -30 cm H₂O is exceeded at which time the inflow valve opens, said inflow valve assisting in increasing blood flow back to the right heart of the person and thereby enhancing the person's blood pressure.

42. A method as in claim 41, wherein the person has low blood pressure due to blood loss.

43. A method as in claim 41, wherein the person has low blood pressure due to the administration of a drug.

44. A method as in claim 41, wherein the person has low blood pressure due to a high gravitational state.

46. A method as in claim 41, wherein the person has low blood pressure secondary to vasovagal syncope.

* * * * *

专利名称(译)	用于增强心肺血流和通气的装置和方法		
公开(公告)号	US20020069878A1	公开(公告)日	2002-06-13
申请号	US09/854238	申请日	2001-05-11
[标]申请(专利权)人(译)	CPRX公司		
申请(专利权)人(译)	CPRX LLC		
当前申请(专利权)人(译)	ZOLL医疗公司		
[标]发明人	LURIE KEITH G ZIELINSKI TODD M		
发明人	LURIE, KEITH G. ZIELINSKI, TODD M.		
IPC分类号	A62B7/04 A61B5/00 A61B5/021 A61B5/08 A61B5/083 A61B5/087 A61B5/145 A61H31/00 A61M16/00 A61M16/04 A61M16/20 A62B9/00 A62B9/02 A62B18/02 C09K5/04 F25B9/00 F25B9/02 F25B31/00 A62B7/00		
CPC分类号	A61H31/005 A61M16/202 A61H31/007 A61H2201/0173 A61H2201/1238 A61H2201/5007 A61H2201 /5048 A61H2201/5058 A61H2201/5071 A61H2201/5089 A61H2201/5097 A61H2230/207 A61H2230/42 A61M16/00 A61M16/0078 A61M16/04 A61M16/20 A61M16/208 A61M2016/0021 C09K5/042 A61M16 /0084 A61H31/006 A61M16/022 A61M16/0858 A61M16/1055 A61M16/106 A61M16/209 A61M2016 /0027 A61M2016/0033		
优先权	10/119203 2002-04-08 US		
其他公开文献	US6604523		
外部链接	Espacenet USPTO		

摘要(译)

根据本发明，提供了用于在进行心肺复苏时增加由胸部按压和减压引起的心肺循环的方法和装置。根据一种方法，压力响应流入阀连接到患者的气道。进行胸部按压和胸部减压。在胸部减压期间，流入阀防止呼吸气体进入肺部，直到超过某个负胸腔内压力水平，此时一个流入阀打开。以这种方式，流入阀有助于在减压期间增加负胸内压的幅度和持续时间，以增强进入心脏和肺的血流量。此外，当流入阀打开以使患者通气时，通过流入阀向患者供应加压呼吸气体。

