



US006671529B2

(12) **United States Patent**
Claire et al.

(10) **Patent No.:** **US 6,671,529 B2**
(45) **Date of Patent:** **Dec. 30, 2003**

(54) **SYSTEM AND METHOD FOR CLOSED LOOP CONTROLLED INSPIRED OXYGEN CONCENTRATION**

(75) Inventors: **Nelson R. Claire**, Miami, FL (US);
Eduardo H. Bancalari, Miami, FL (US)

(73) Assignee: **University of Miami**, Miami, FL (US)

(*) Notice: Subject to any disclaimer, the term of this patent is extended or adjusted under 35 U.S.C. 154(b) by 0 days.

(21) Appl. No.: **10/306,643**

(22) Filed: **Nov. 27, 2002**

(65) **Prior Publication Data**

US 2003/0078480 A1 Apr. 24, 2003

Related U.S. Application Data

(62) Division of application No. 09/735,319, filed on Dec. 12, 2000, now Pat. No. 6,512,938.

(51) **Int. Cl.⁷** **A61B 5/00**

(52) **U.S. Cl.** **600/323**

(58) **Field of Search** 600/323, 322, 600/326, 328, 301; 128/204.22, 204.23, 204.21, 205.11

(56) **References Cited**

U.S. PATENT DOCUMENTS

2,414,747 A 1/1947 Kirschbaum
3,734,091 A 5/1973 Taplin

(List continued on next page.)

FOREIGN PATENT DOCUMENTS

EP 0658331 6/1995

OTHER PUBLICATIONS

P.E. Morozoff & R.W. Evans. "Closed-Loop Control of Sao₂ in the Neonate". (Biomedical Instrumentation & Technology 1992; 26:117-123).

(List continued on next page.)

Primary Examiner—Kevin Shaver

Assistant Examiner—Anuradha Ramana

(74) *Attorney, Agent, or Firm*—Stetina Brunda Garred & Brucker

(57) **ABSTRACT**

A system and method for delivering fractionally inspired oxygen (FiO₂) to a patient in response to receiving an arterial hemoglobin oxygen saturation signal (SpO₂) are disclosed. The SpO₂ is measured, for example, by using a pulse oximeter. An algorithm receives a signal indicating the SpO₂. The algorithm determines whether the SpO₂ is in the normoxemia range, hypoxemia range or hyperoxemia range. The algorithm also determines trends by calculating a slope of second-to-second changes in the SpO₂. Based on the current SpO₂ and the trend, the algorithm determines the appropriate FiO₂ for the patient and instructs a device, such as a mechanical ventilator or an air oxygen mixer as to the appropriate FiO₂ to be delivered to the patient. The system initializes various parameters with default values, but a user (e.g., a nurse) can also update the settings at any time. The system also provides alerts for various conditions, for example, standard pulse oximeter alarms, as well as notification when an episode of hyperoxemia or hypoxemia occurs, when it lasts for more than a specified period of time (e.g., two minutes) in spite of FiO₂ adjustments and when the adjustments set the FiO₂ at certain levels. The user is also alerted when SpO₂ signal is lost.

5 Claims, 39 Drawing Sheets

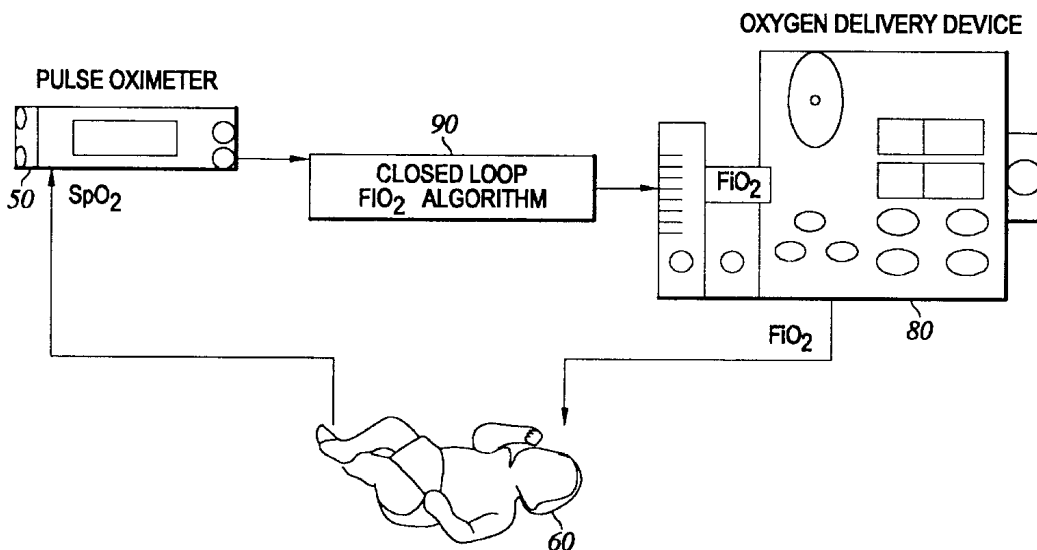

U.S. PATENT DOCUMENTS

4,121,578	A	10/1978	Torzala	
4,326,513	A	4/1982	Schulz et al.	
4,612,928	A	9/1986	Tiep et al.	
4,665,911	A	5/1987	Williams et al.	
4,671,297	A	6/1987	Schulze, Jr.	
4,869,253	A	9/1989	Craig et al.	
4,889,116	A	12/1989	Taube	
4,932,402	A	6/1990	Snook et al.	
4,972,842	A	11/1990	Korten et al.	
4,986,268	A	1/1991	Tehrani	
5,103,814	A	4/1992	Maher	
5,119,815	A	6/1992	Chance	
5,251,632	A	10/1993	Delpy	
5,315,990	A	5/1994	Mondry	
5,365,922	A	11/1994	Raemer	
5,388,575	A	2/1995	Taube	
5,560,352	A	10/1996	Heim et al.	
5,682,877	A	11/1997	Mondry	
5,752,509	A	5/1998	Lachmann et al.	
6,035,223	A	3/2000	Baker, Jr.	
6,148,814	A	11/2000	Clemmer et al.	
6,186,142	B1	* 2/2001	Schmidt et al.	128/204.23
6,192,260	B1	2/2001	Chance	
6,272,363	B1	8/2001	Casciani et al.	
6,371,114	B1	* 4/2002	Schmidt et al.	128/204.23
6,387,324	B1	5/2002	Patterson et al.	

OTHER PUBLICATIONS

Thomas East et al. "Can Pulse Oximetry be Used to Reliably Predict Arterial Oxygenation". (Society of Critical Care Medicine Jan.-Feb. 1995; poster presentation).

Vinod K. Bhutani et al. "Adaptive Control of Inspired Oxygen Delivery to the Neonate" (Pediatric Pulmonology 1992; 14:110-117).

Fleur T. Tehrani. "A Microcomputer Oxygen Control System for Ventilatory Therapy". (Annals of Biomedical Engineering 1992; vol. 20:547-558).

Thomas P. Laubscher et al. "Automatic Selection of Tidal Volume, . . . for Close-Loop Controlled Ventilation". (International Journal of Clinical Monitoring and Computing 1994; 11:10-30).

Michael Jastremski et al. "A Model for Technology Assessment as Applied to Closed Loop Infusion Systems". (Critical Care Medicine Oct. 1995; vol. 23:1-18).

F. Lemaire & Alain Hart. "A Knowledge-Based System for Assisted Ventilation of Patients in ICU". (International Journal of Clinical Monitoring and Computing 1992; 9:239-250).

Dwayne R. Westenskow. "Automating Patient Care with Closed-Loop Control". (Images, Signals and Devices 1986; vol. 3, No. 2, pp. 14-20).

M. Blasovszky et al. "Improving Instrumentation for Hospital Care of Neonates in Hungary". (IEEE Engineering In Medicine and Biology Mar.-Apr. 1998; pp. 59-65).

Norbert Weiler et al. "Adaptive Lung Ventilation . . . Automatic Response to Transitions to and from One-Lung Ventilation". (Journal of Clinical Monitoring and Computing 1998; 14:245-252).

1999 Abstract Form from 1999 ALA/ATS International Conference (2 pages) with hard copy of Power Point presentation (22 pages) presented at American Thoracic Society-American Lung Association meeting in Apr. of 1999 in San Diego California and at the Society of Pediatric Research-American Academy of Pediatric meeting in May of 1999 in San Francisco, California. Abstract and documents apply to both meetings.

James H. Strickland et al. "A Computer-Controlled Ventilator Weaning System". (Chest 1991; vol. 100:pp. 1096-1099).

Suzanne M. Burns. "Weaning from Mechanical Ventilation: A Method for Assessment and Planning". (Clinical Issues Aug. 1991; vol. 2, No. 3, pp. 372-387).

Hillary Don. "Hypoxemia". pp. 62-63.

* cited by examiner

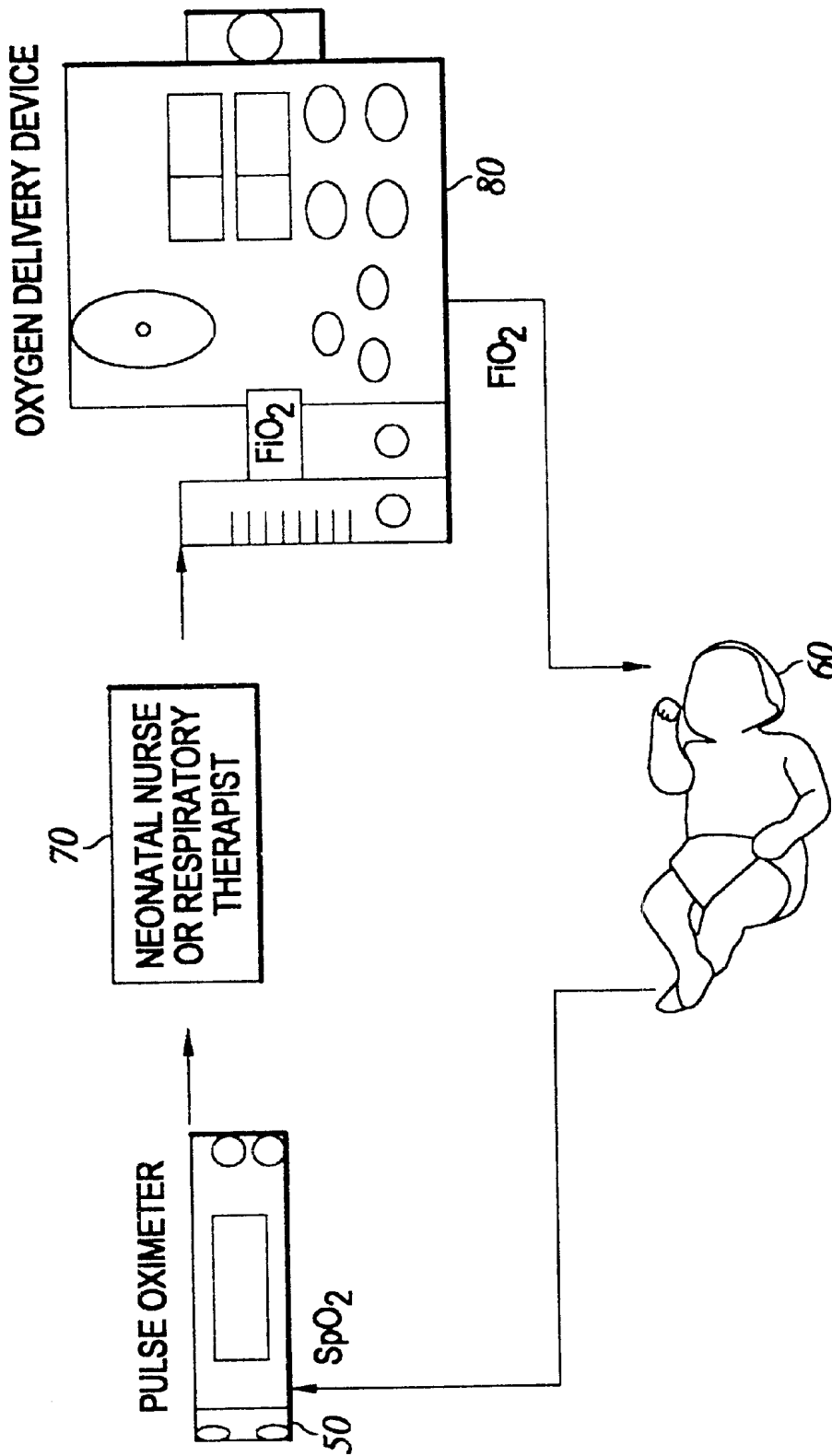

(PRIOR ART)
Fig. 1

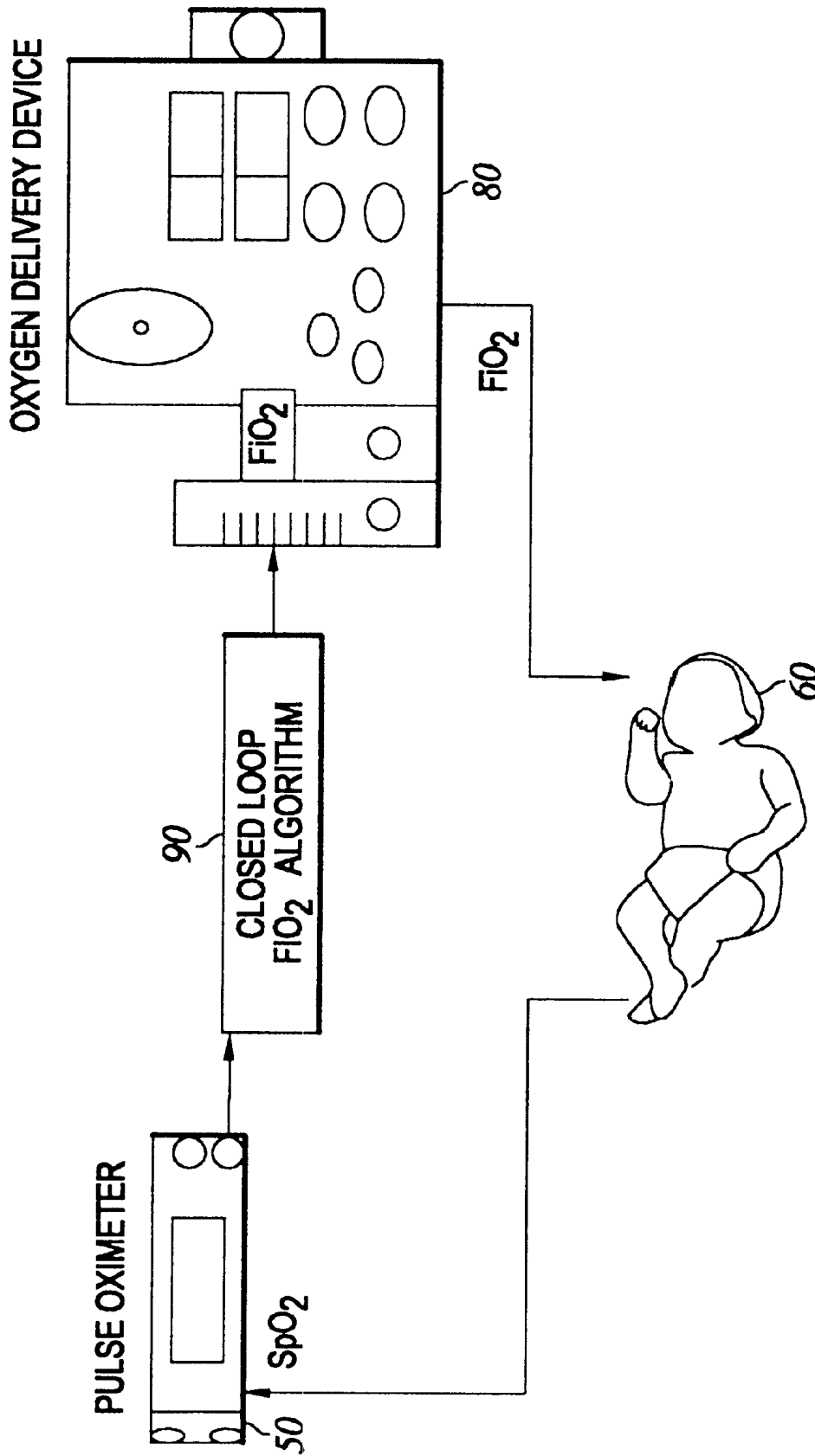

Fig. 2

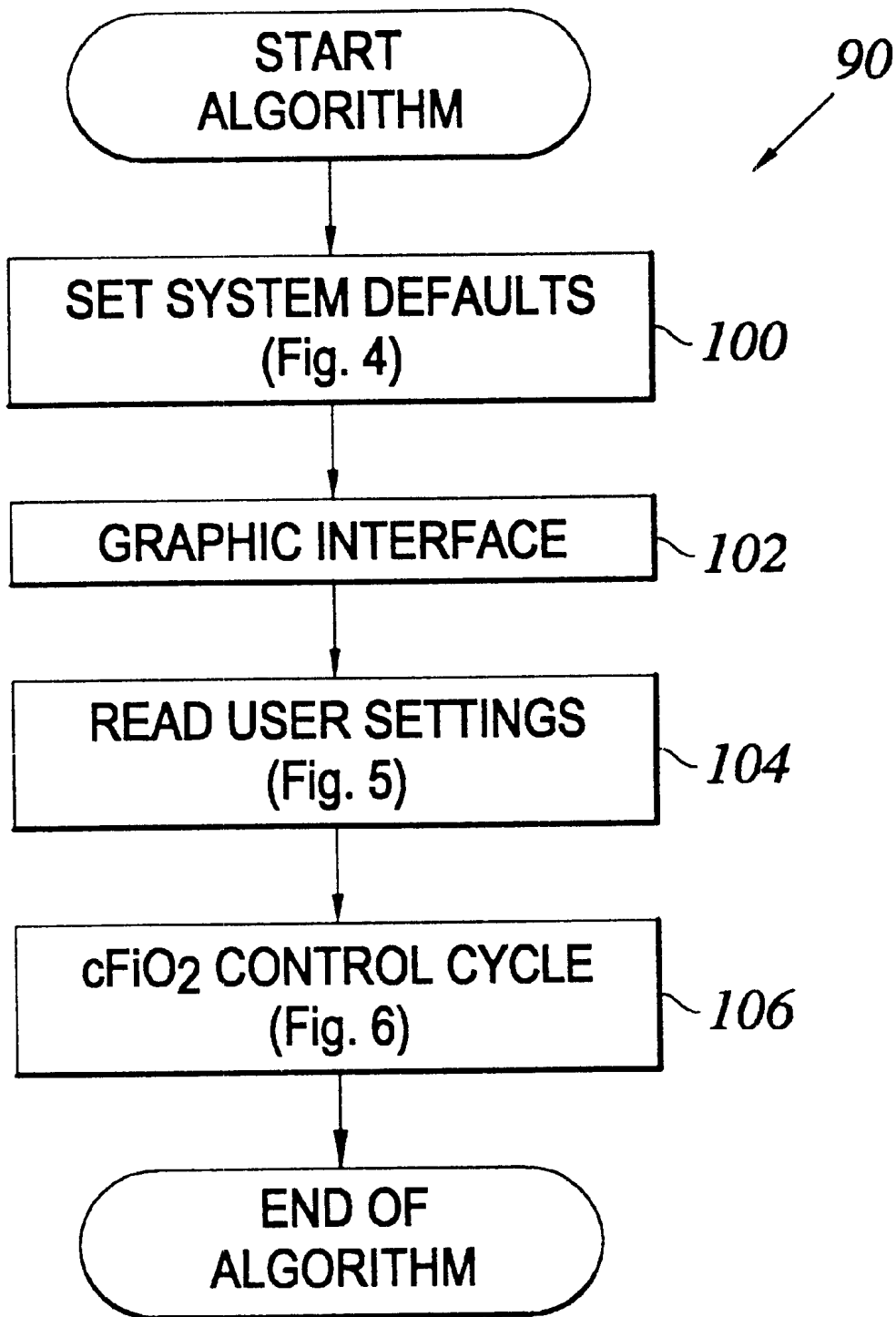

Fig. 3

<u>Parameter</u>	<u>Default Value</u>
Sampling/Update Rate	1 Hz
SpO ₂ OK High Limit	100%
SpO ₂ OK Low Limit	20%
SpO ₂ OK Time Min	5 sec.
SpO ₂ Out Time Min	5 sec.
SpO ₂ Time in High Norm Low Range Min	3 sec.
SpO ₂ Time to Zero Counters	10 sec.
SpO ₂ Norm Adjust Interval	40 sec., 20 - 60 sec.
SpO ₂ Norm Wean Interval	45 sec.
SpO ₂ Norm Base Calc Min Interval	30 sec.
SpO ₂ Normal Base	94%
SpO ₂ Slope High Limit	5%/sec.
SpO ₂ Slope Low Limit	-5%/sec.
SpO ₂ High Wean Level	30 sec.
SpO ₂ Hight Adjust Interval	30 sec., 20 - 60 sec.
SpO ₂ Low Adjust Interval	20 sec., 5 - 40 sec.
SpO ₂ Low Alarm Limit	60 sec.
FiO ₂ Base High Limit	60%
FiO ₂ Base Calc Interval	300 sec.
FiO ₂ at Min for Base Calc Interval	30 sec.
FiO ₂ at Max for Base Calc Interval	60 sec.
FiO ₂ Max	100%

Fig. 4

<u>User Setting</u>	<u>Valid Range</u>	<u>Default Value</u>
SpO ₂ Target Range High Limit	94 - 100%	96%
SpO ₂ Target Range Low Limit	85 - 94%	88%
FiO ₂ Base	21 - 60%	30%
FiO ₂ Backup	21 - 100%	40%
FiO ₂ Min		21%
FiO ₂ Set	(same as FiO ₂ Base on control start)	
Control Switch	ON or OFF	OFF
FiO ₂ Base Calculation Switch	ON or OFF	OFF

Fig. 5

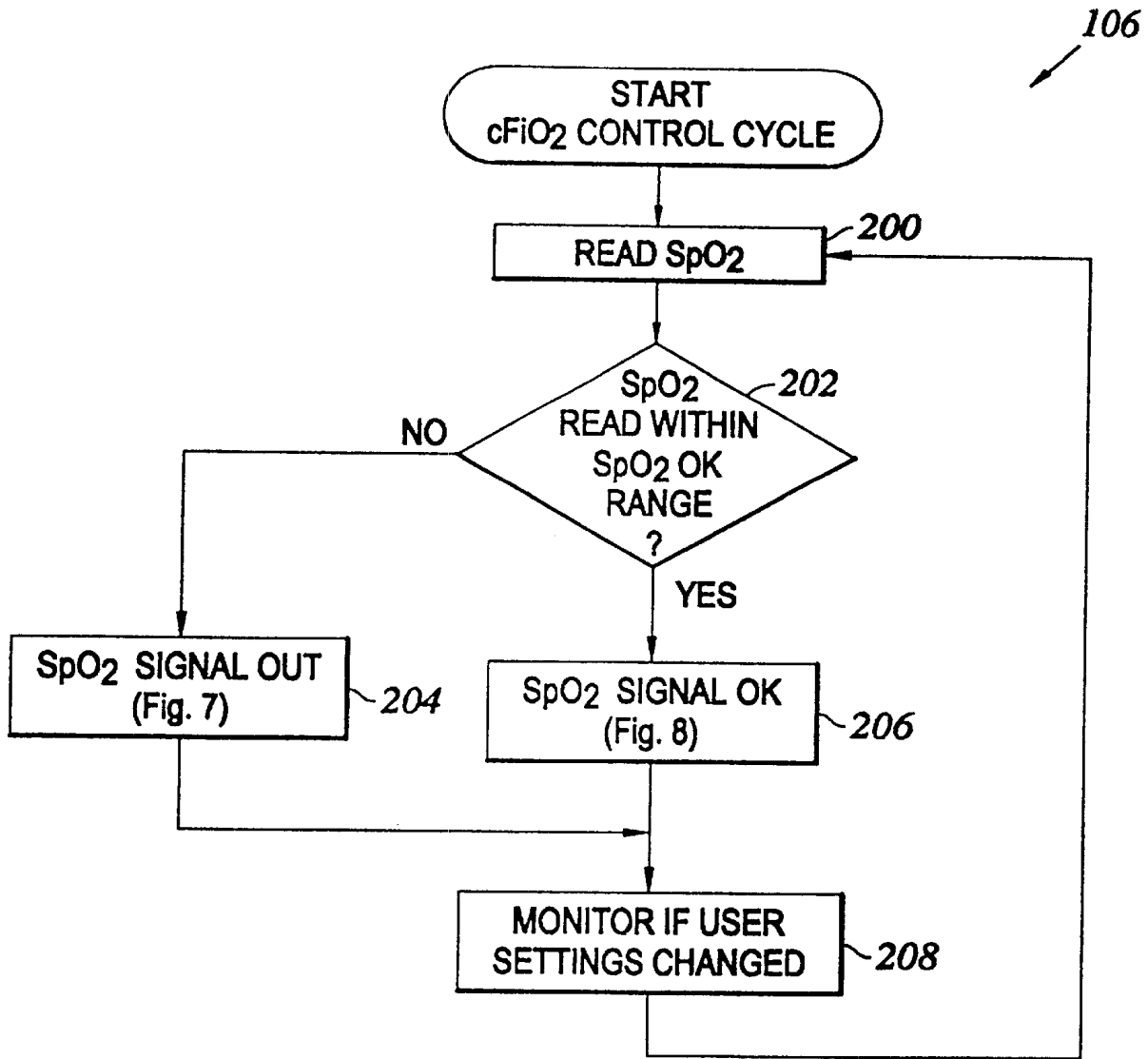

Fig. 6

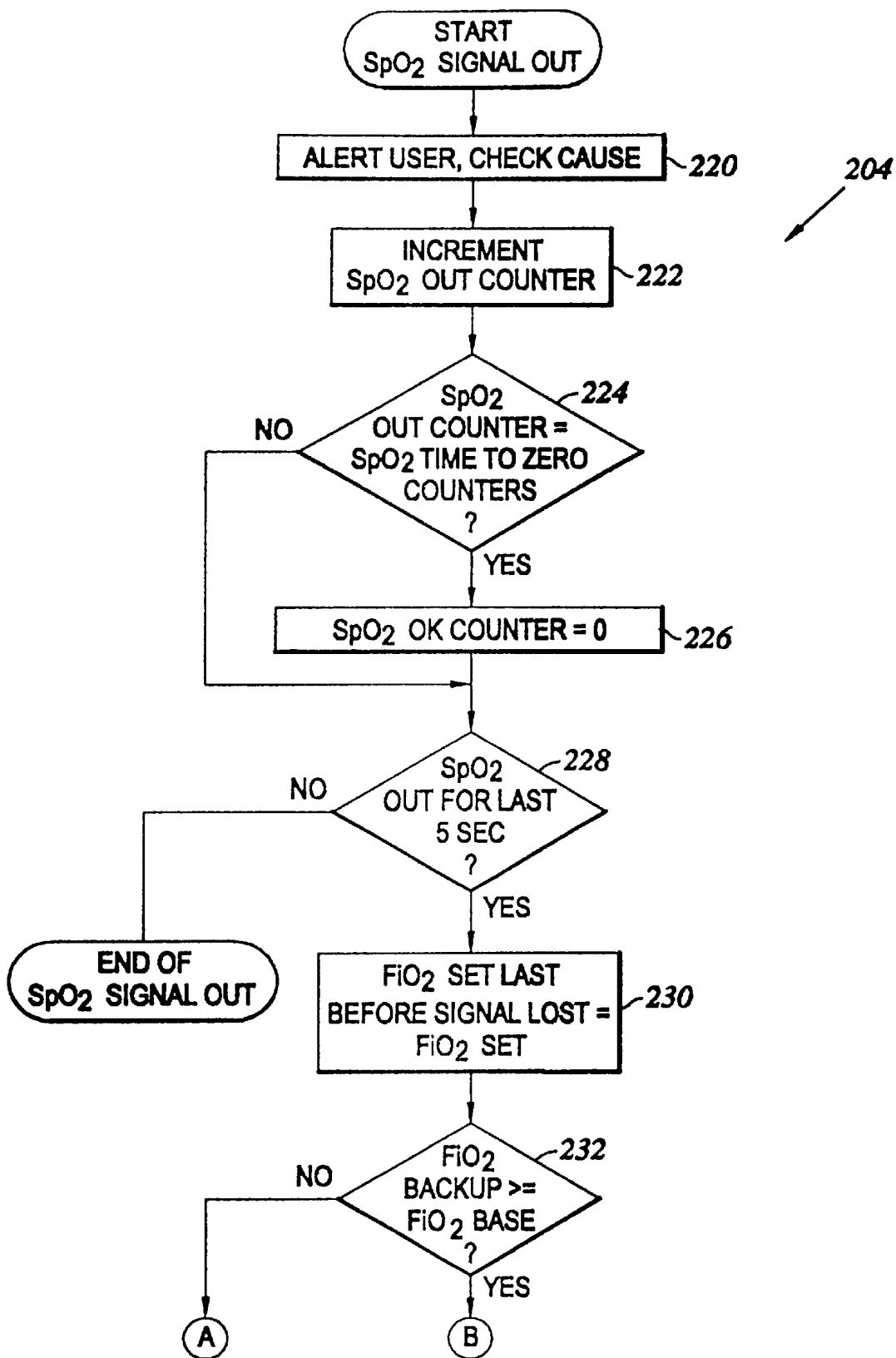

Fig. 7A

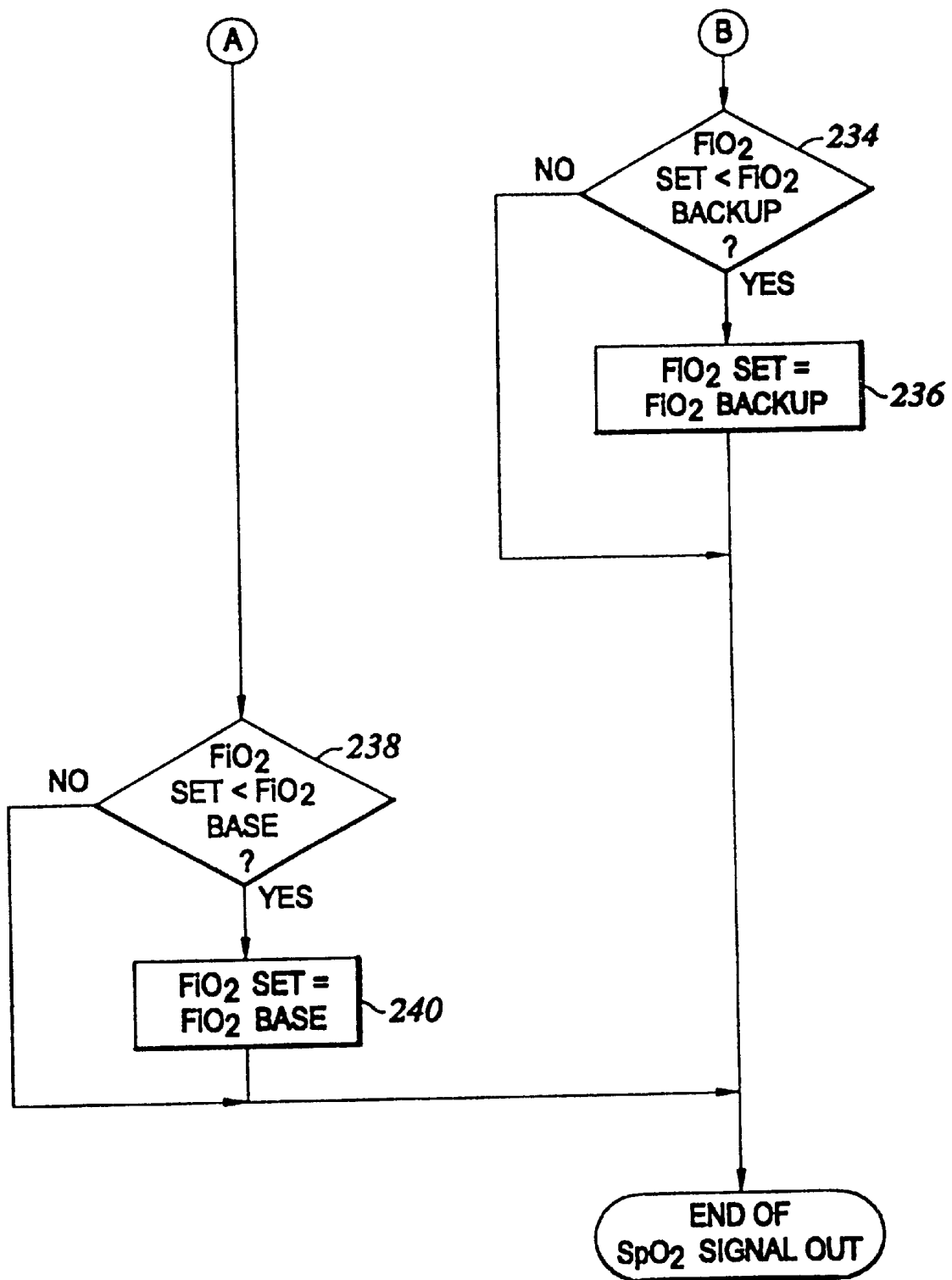

Fig. 7B

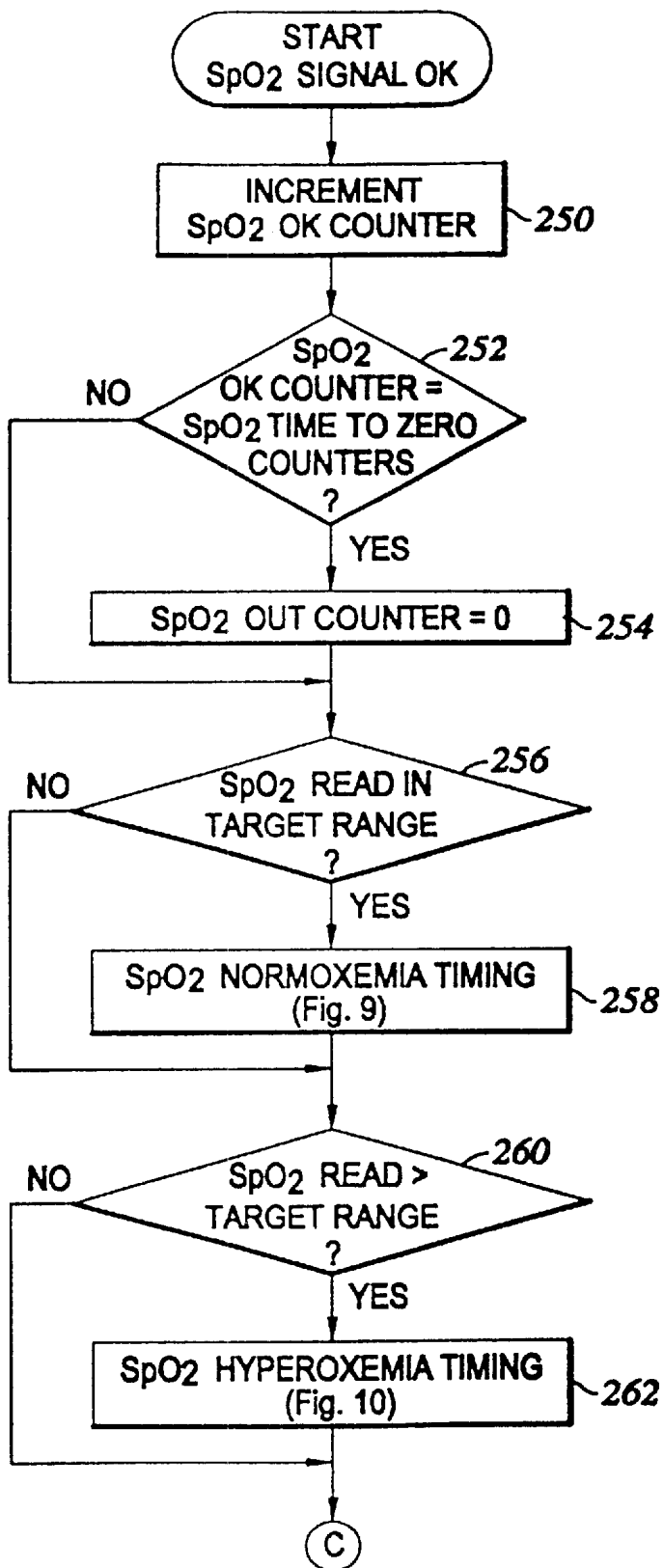

Fig. 8A

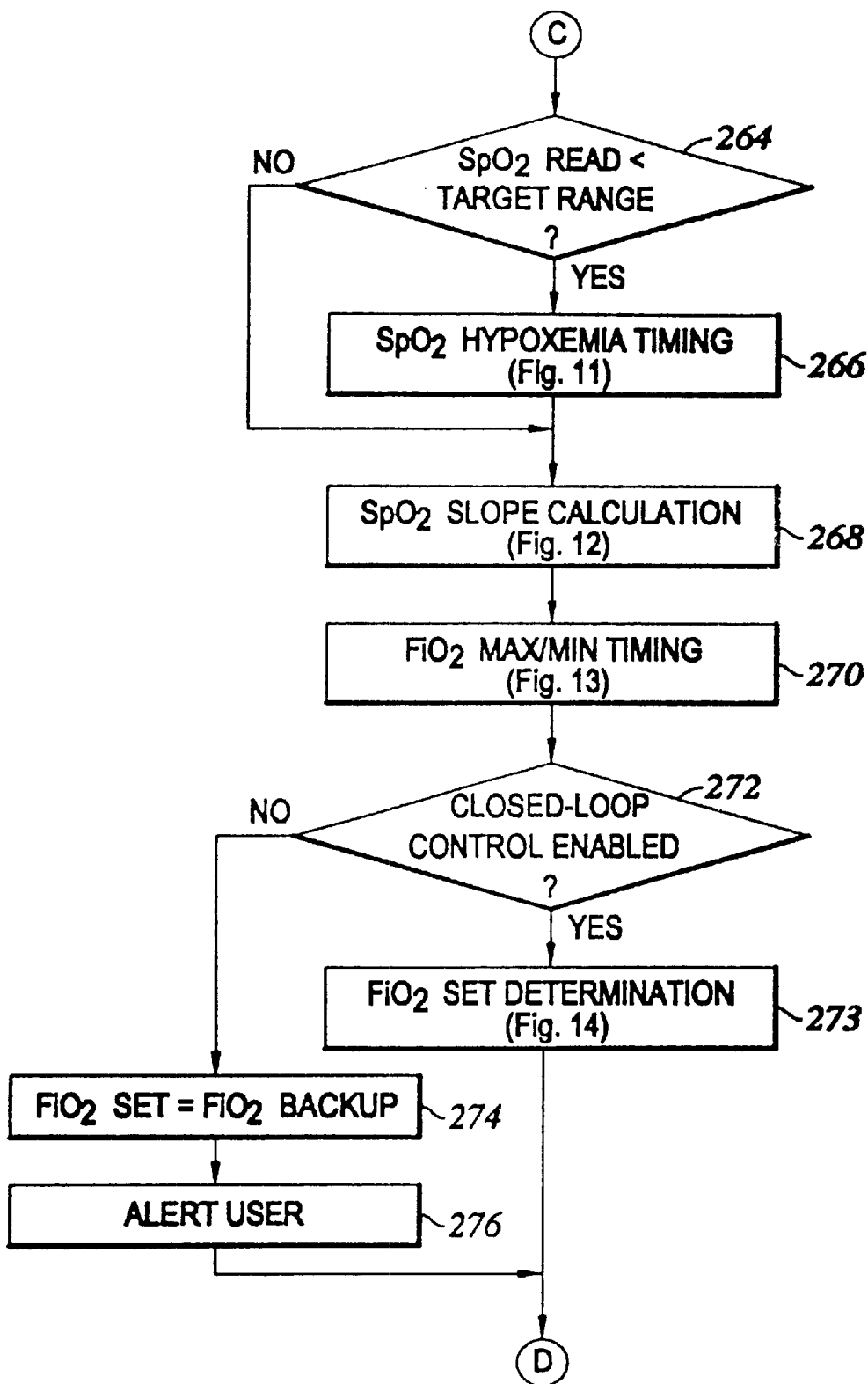

Fig. 8B

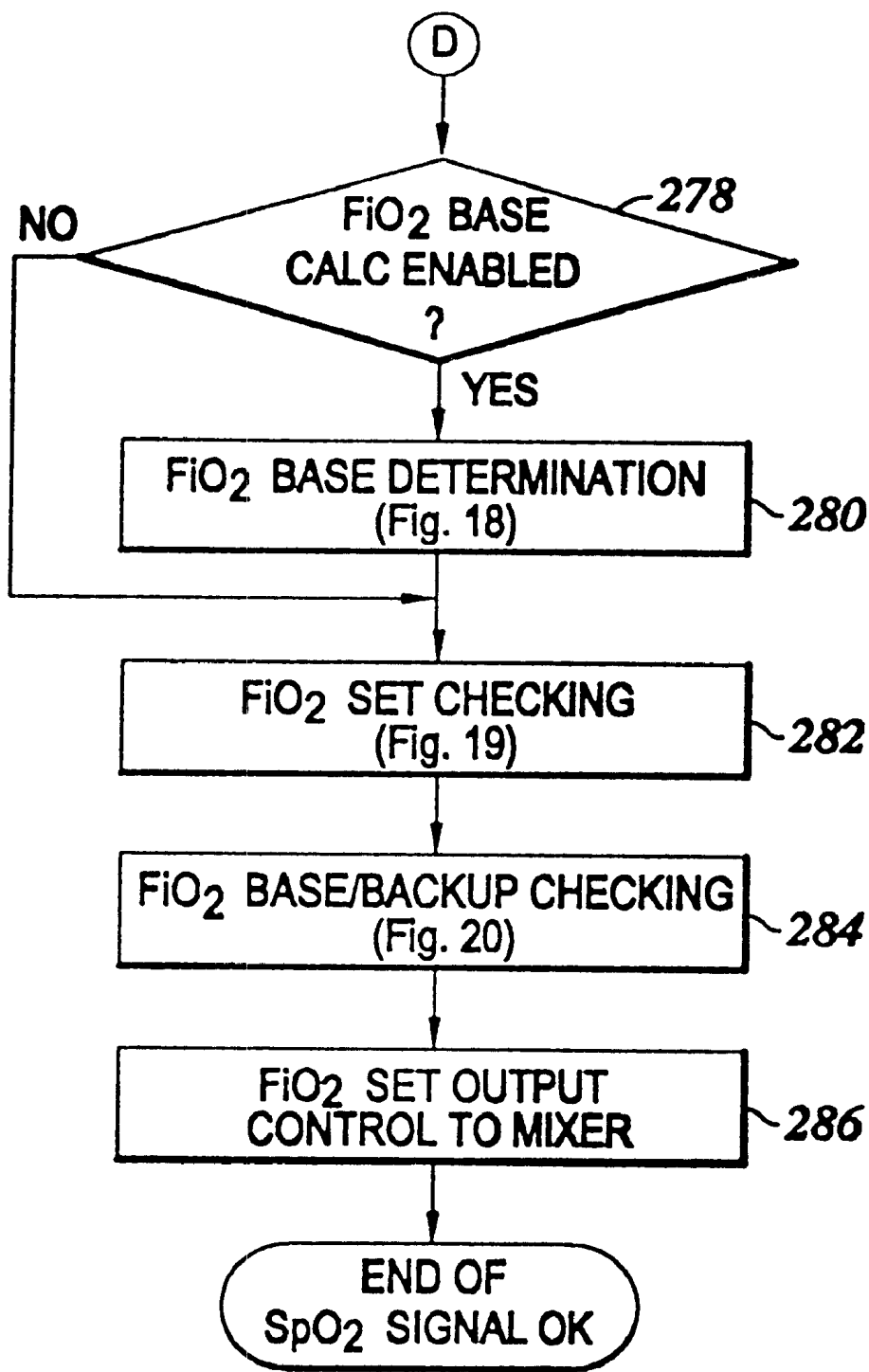

Fig. 8C

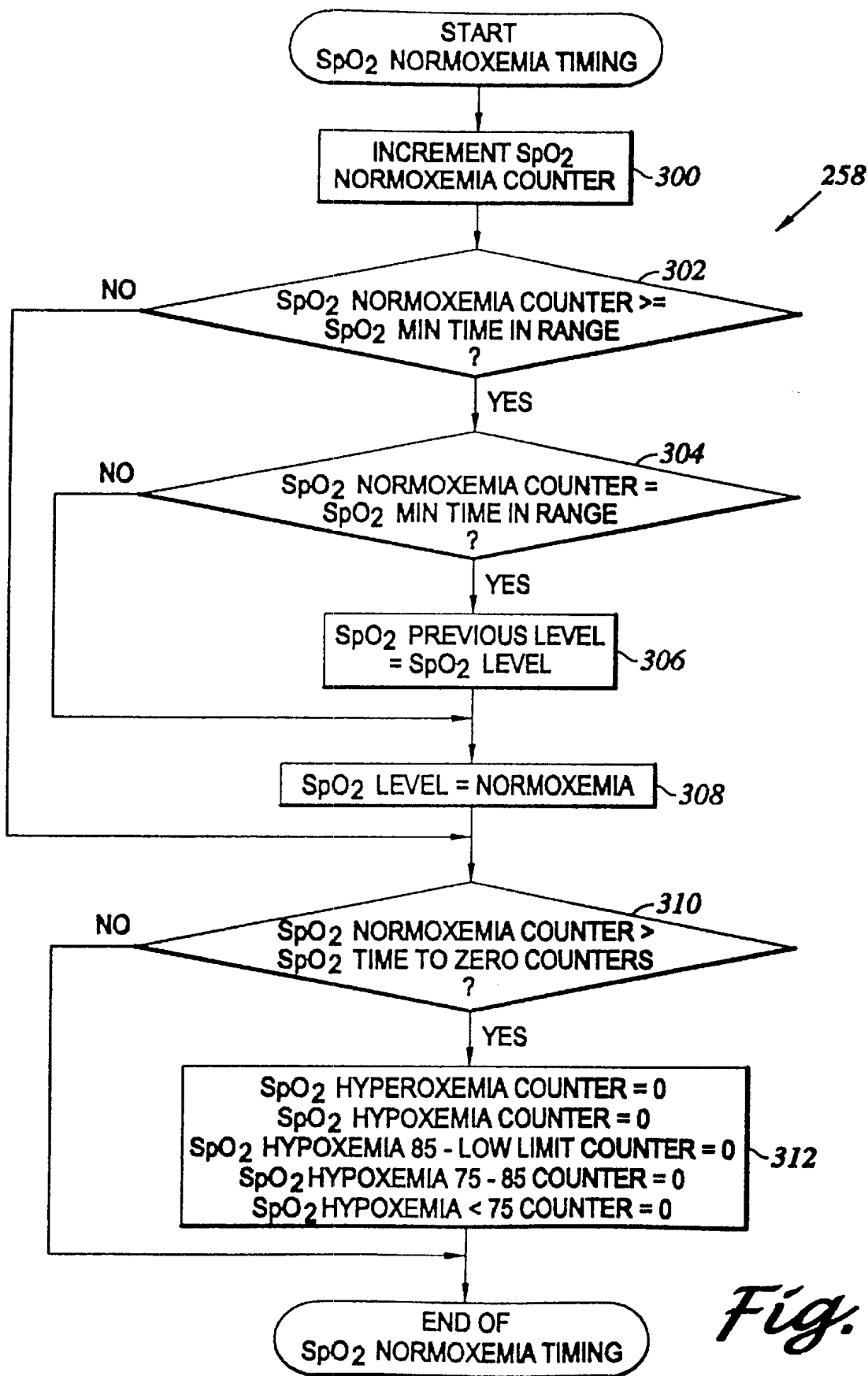

Fig. 9

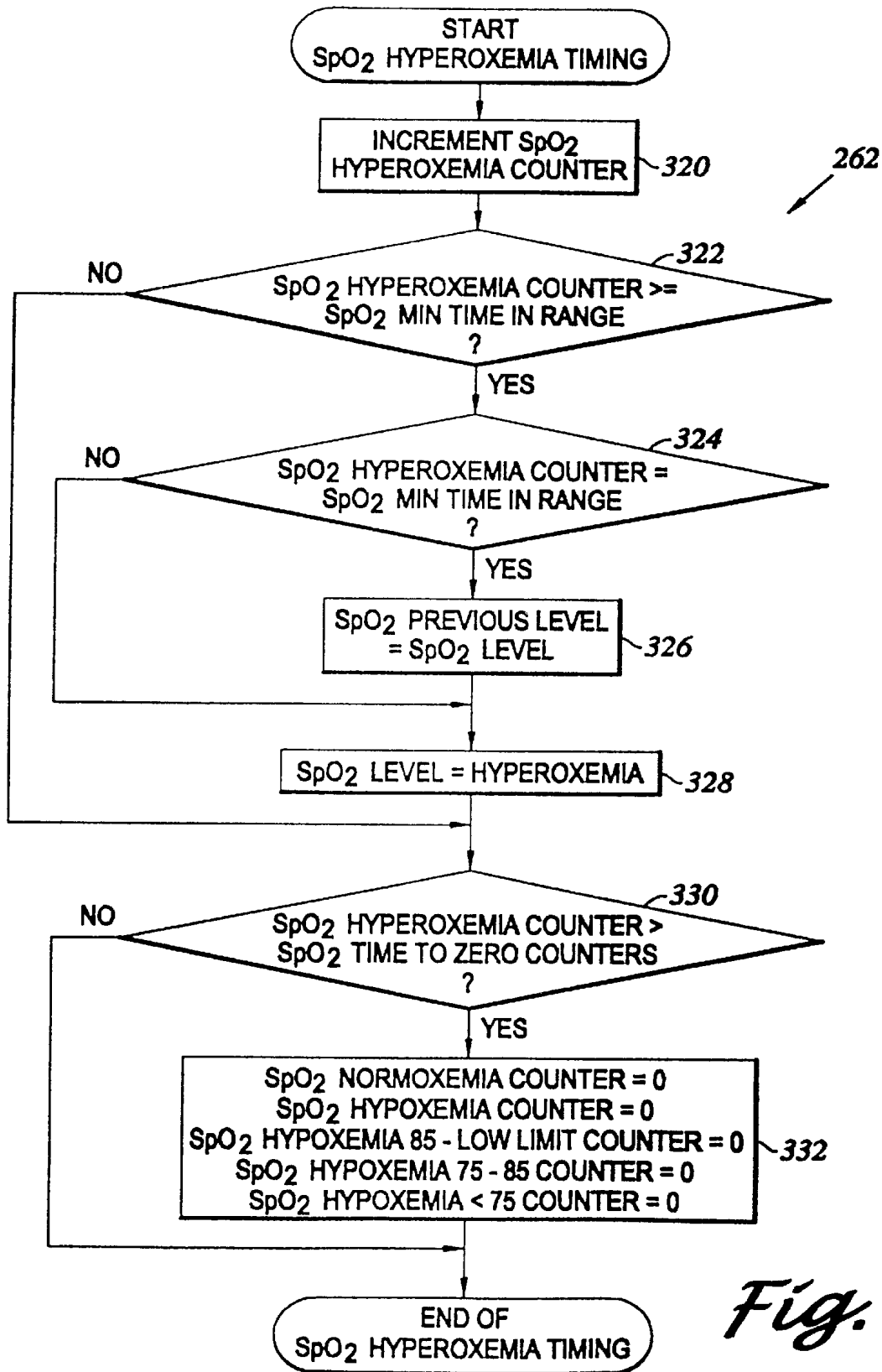

Fig. 10

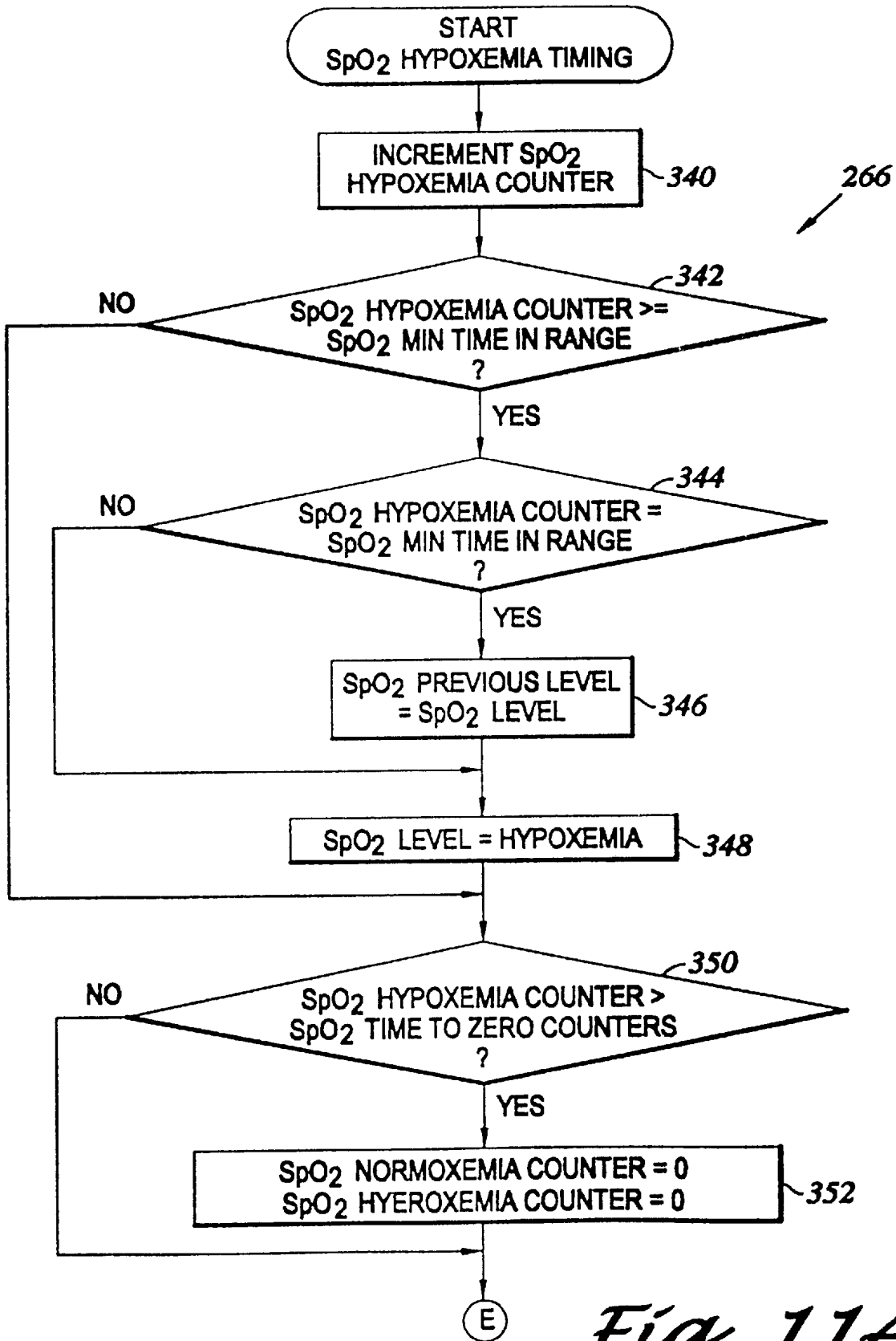

Fig. 11A

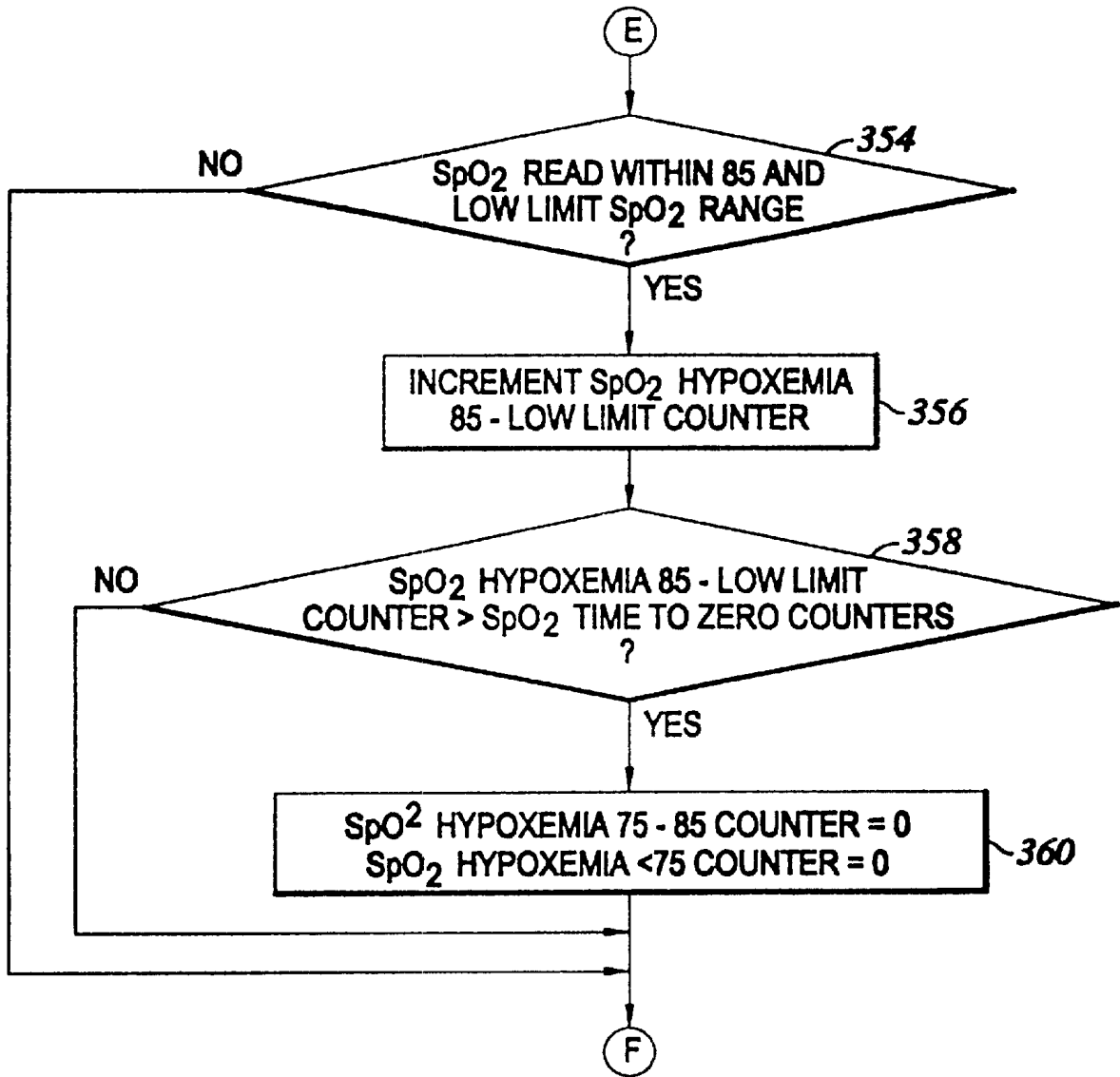

Fig. 11B

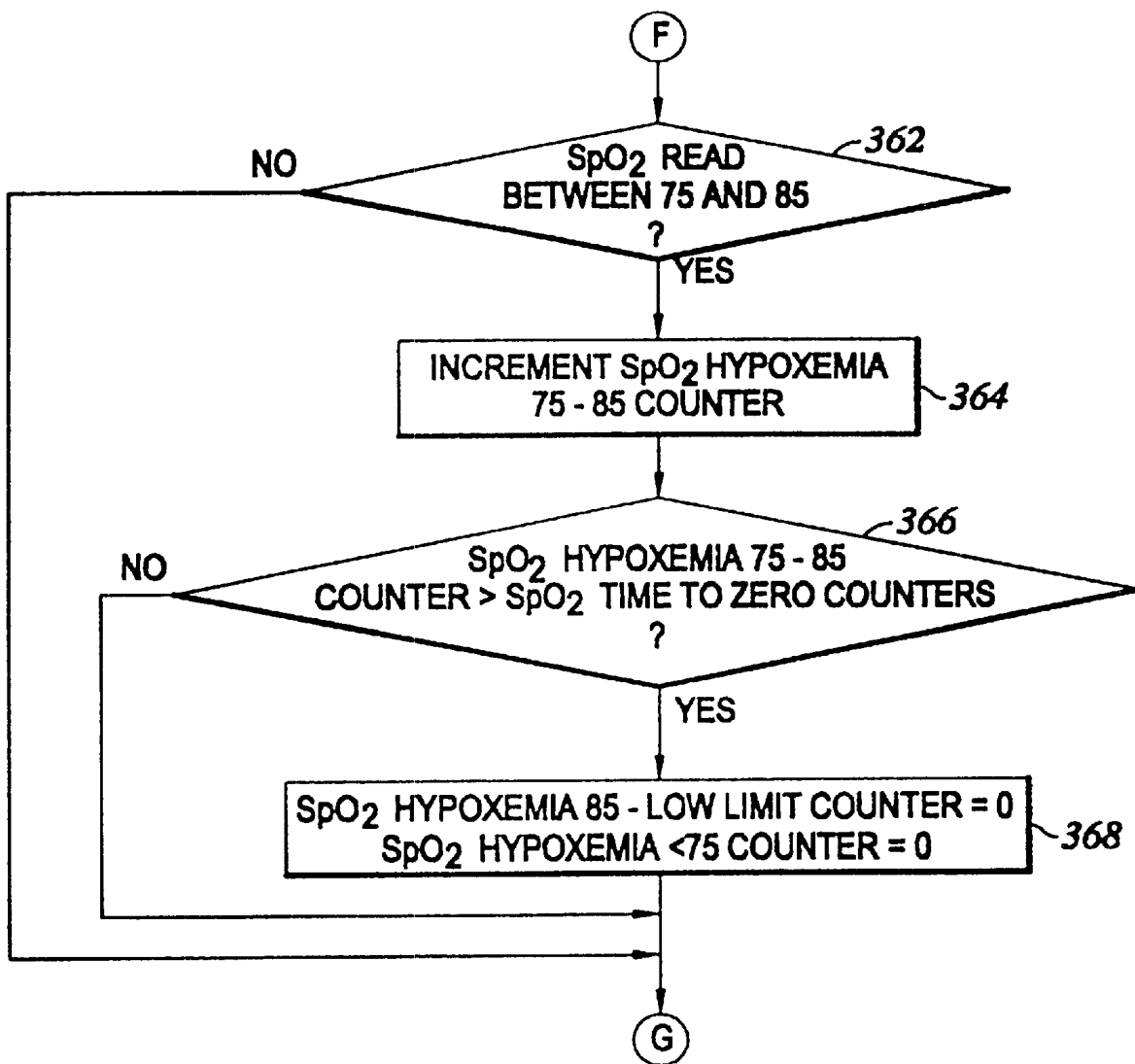

Fig. 11C

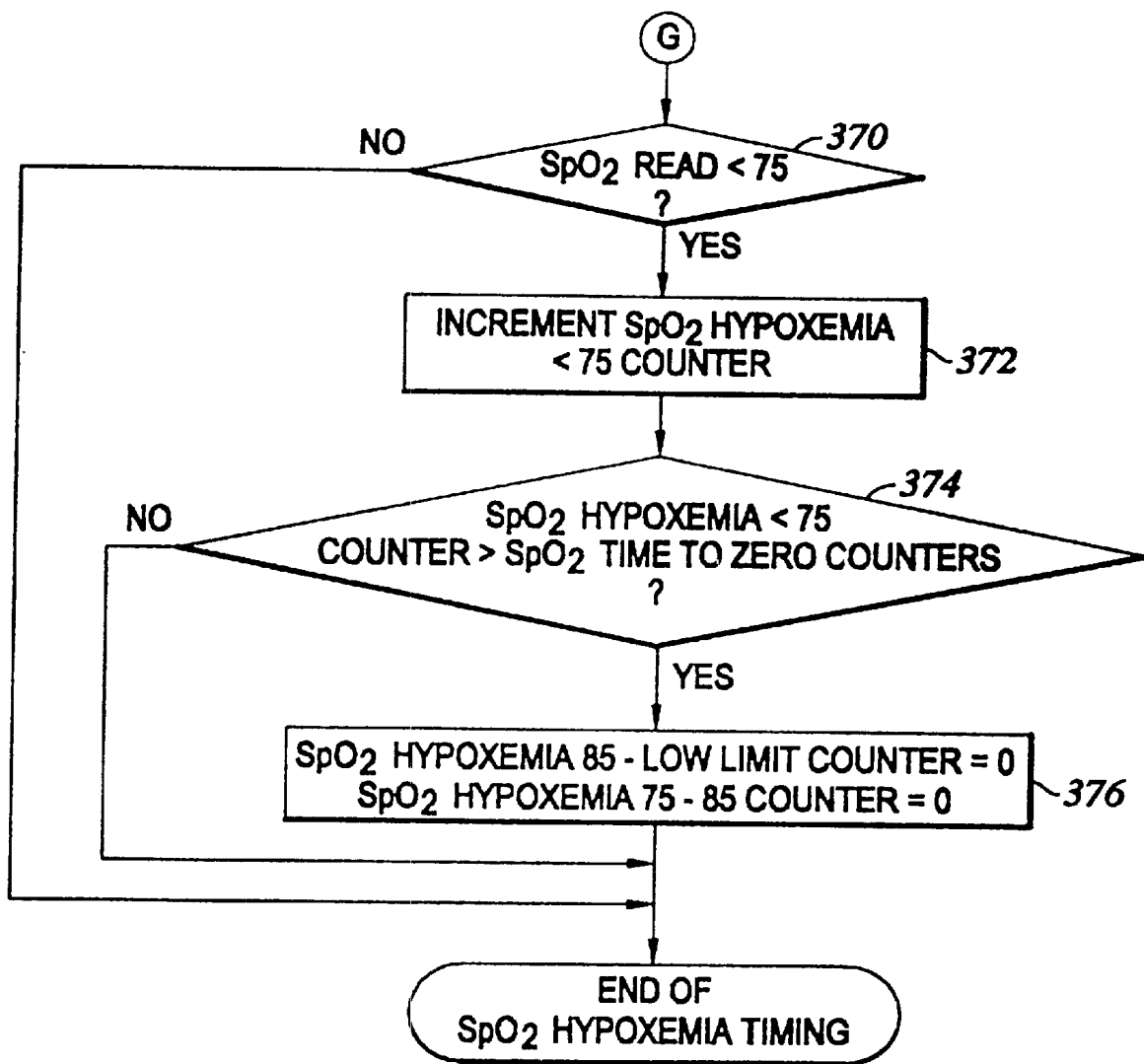

Fig. 11D

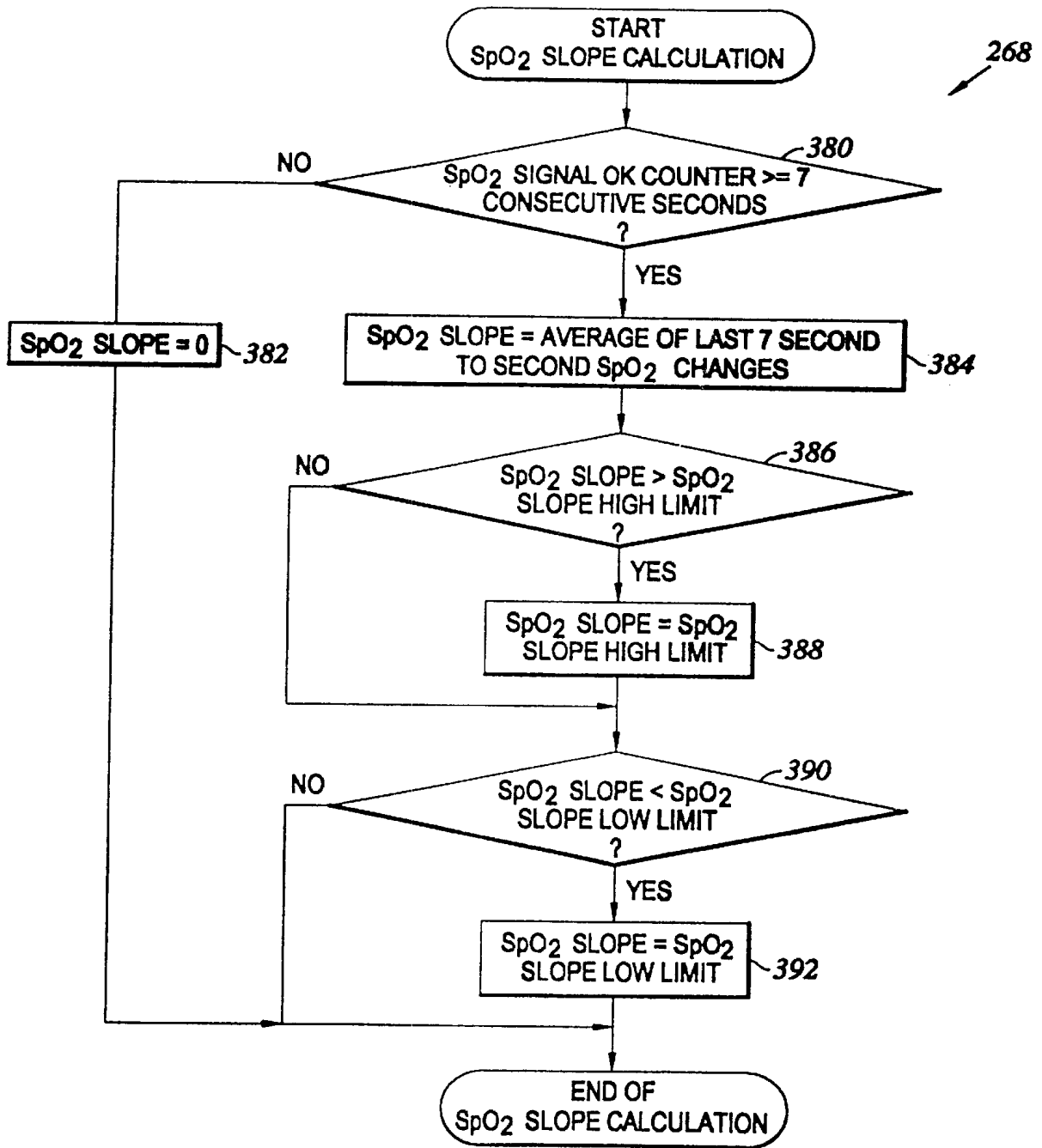

Fig. 12

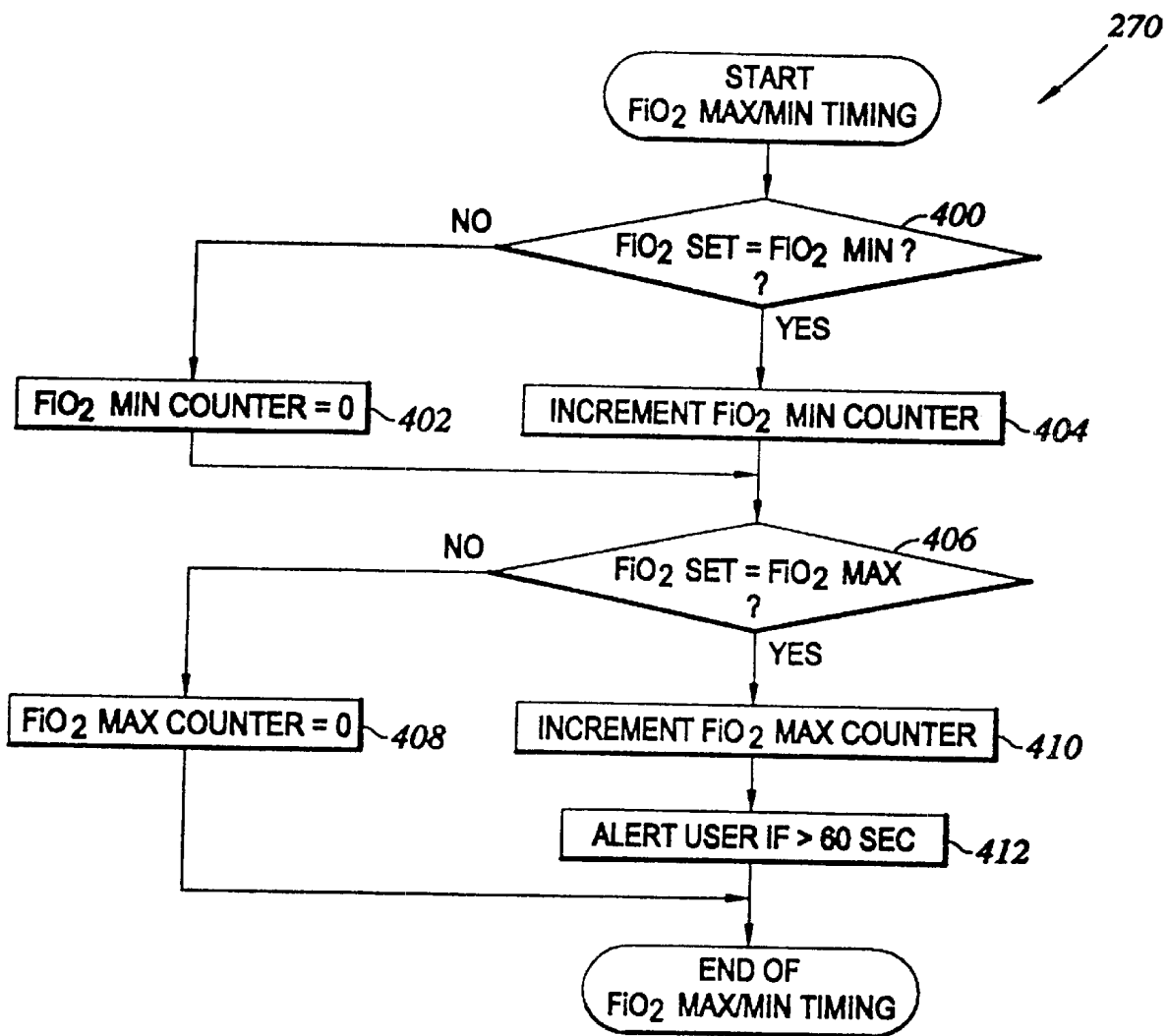

Fig. 13

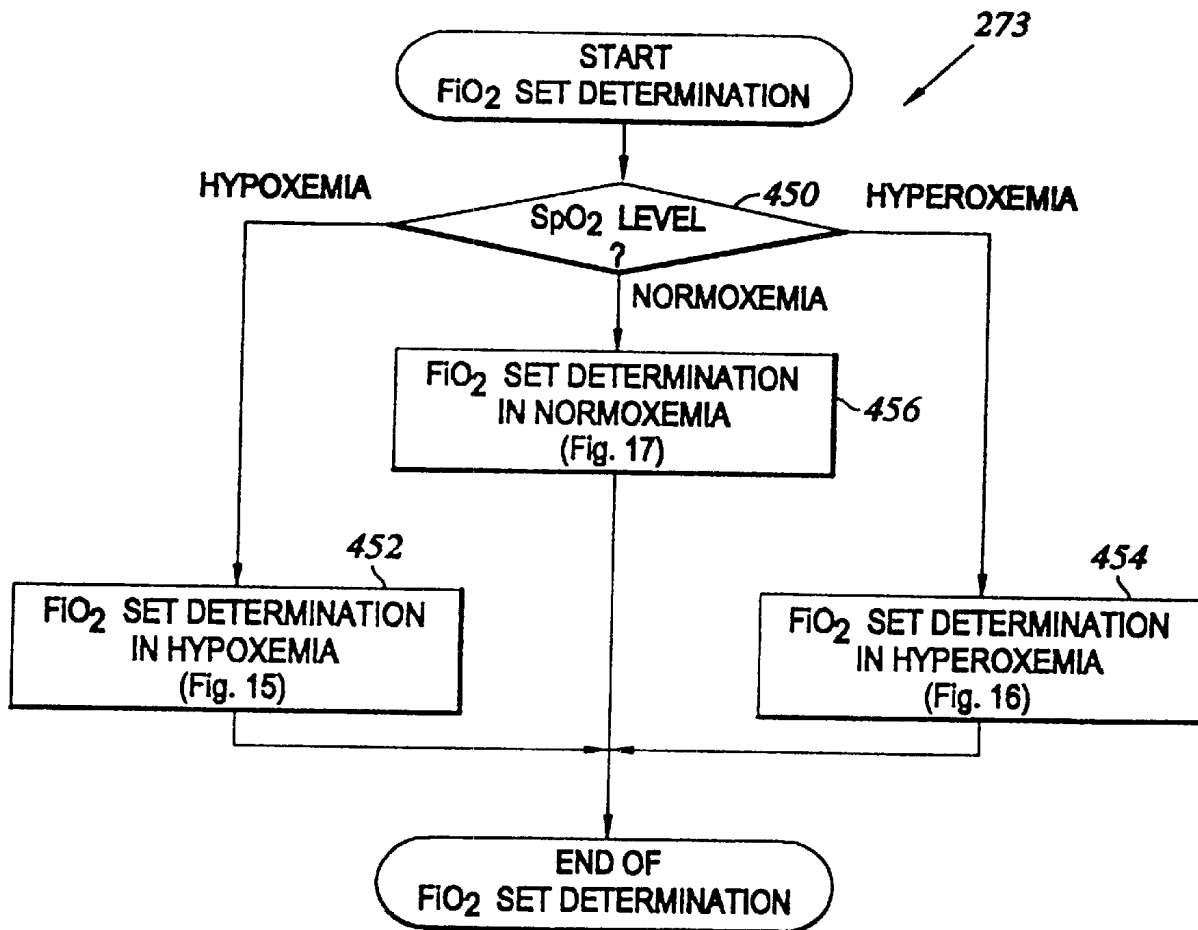

Fig. 14

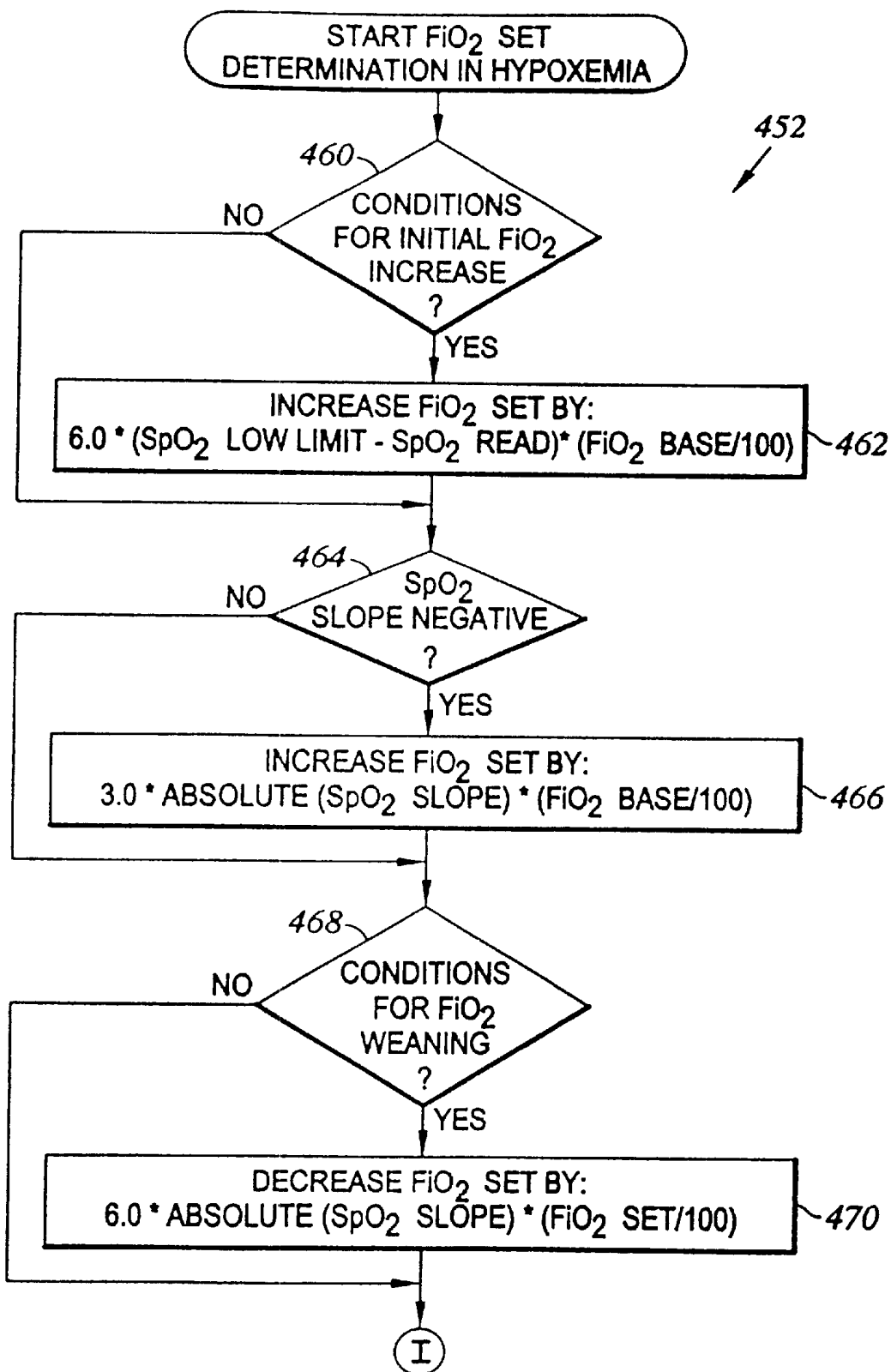

Fig. 15A

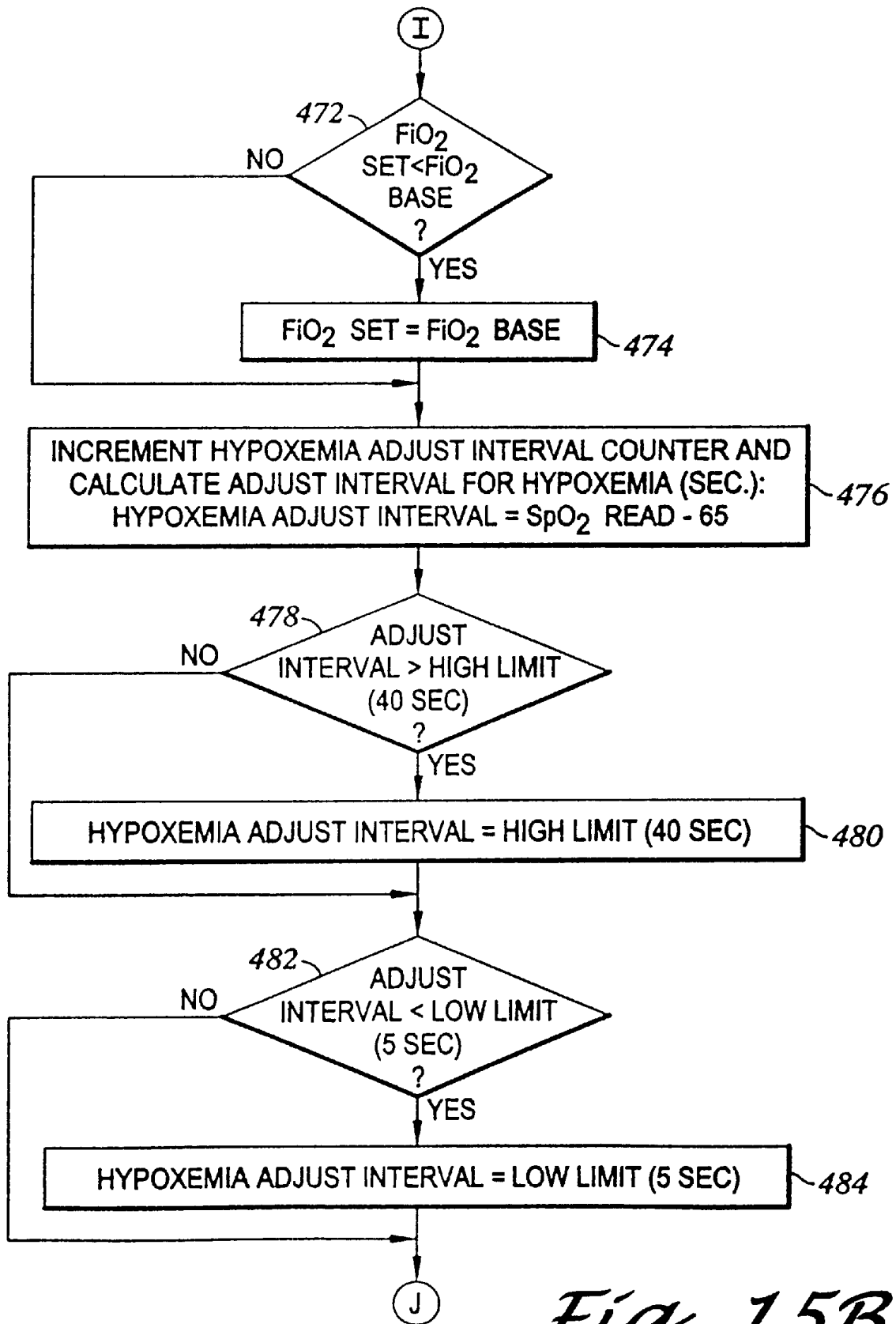

Fig. 15B

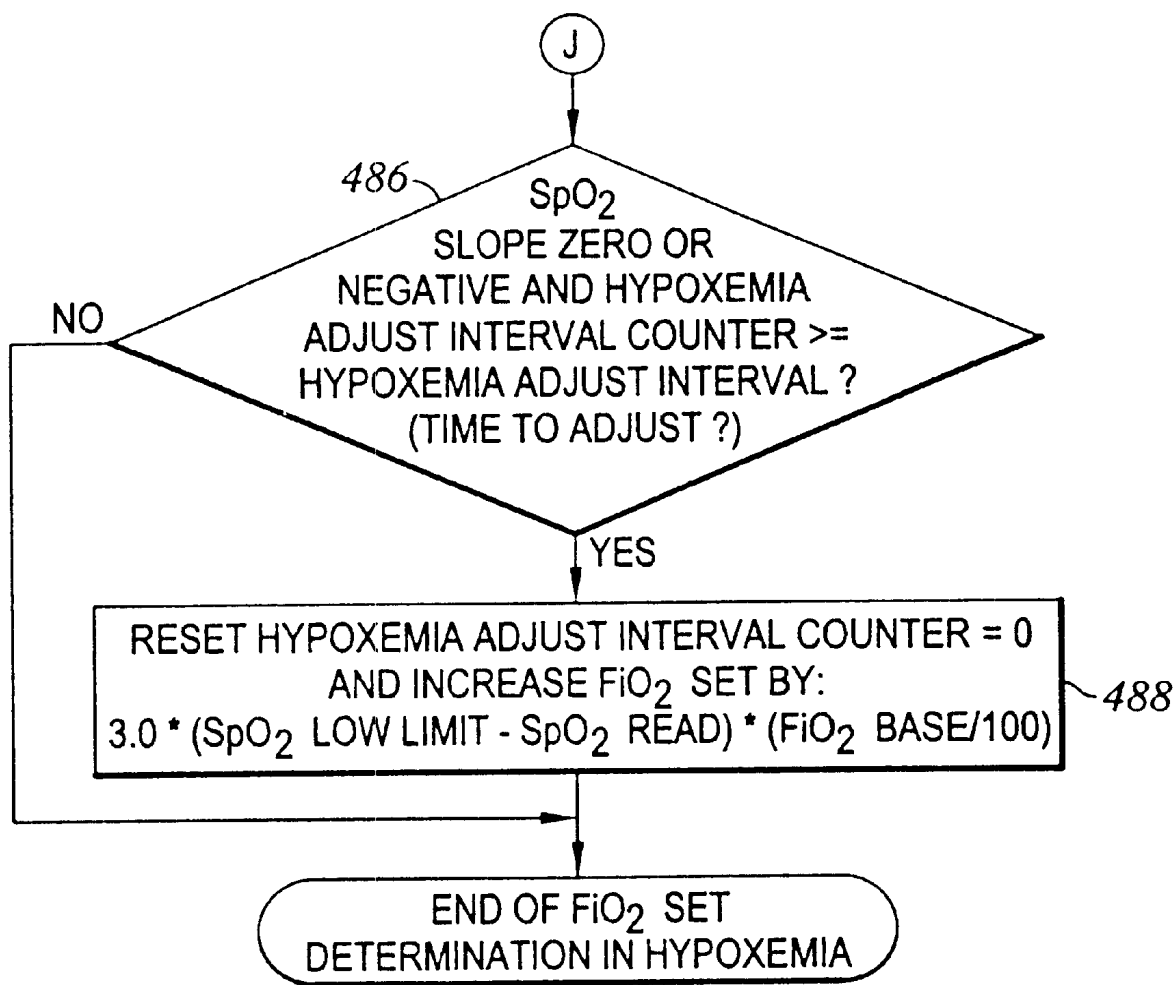

Fig. 15C

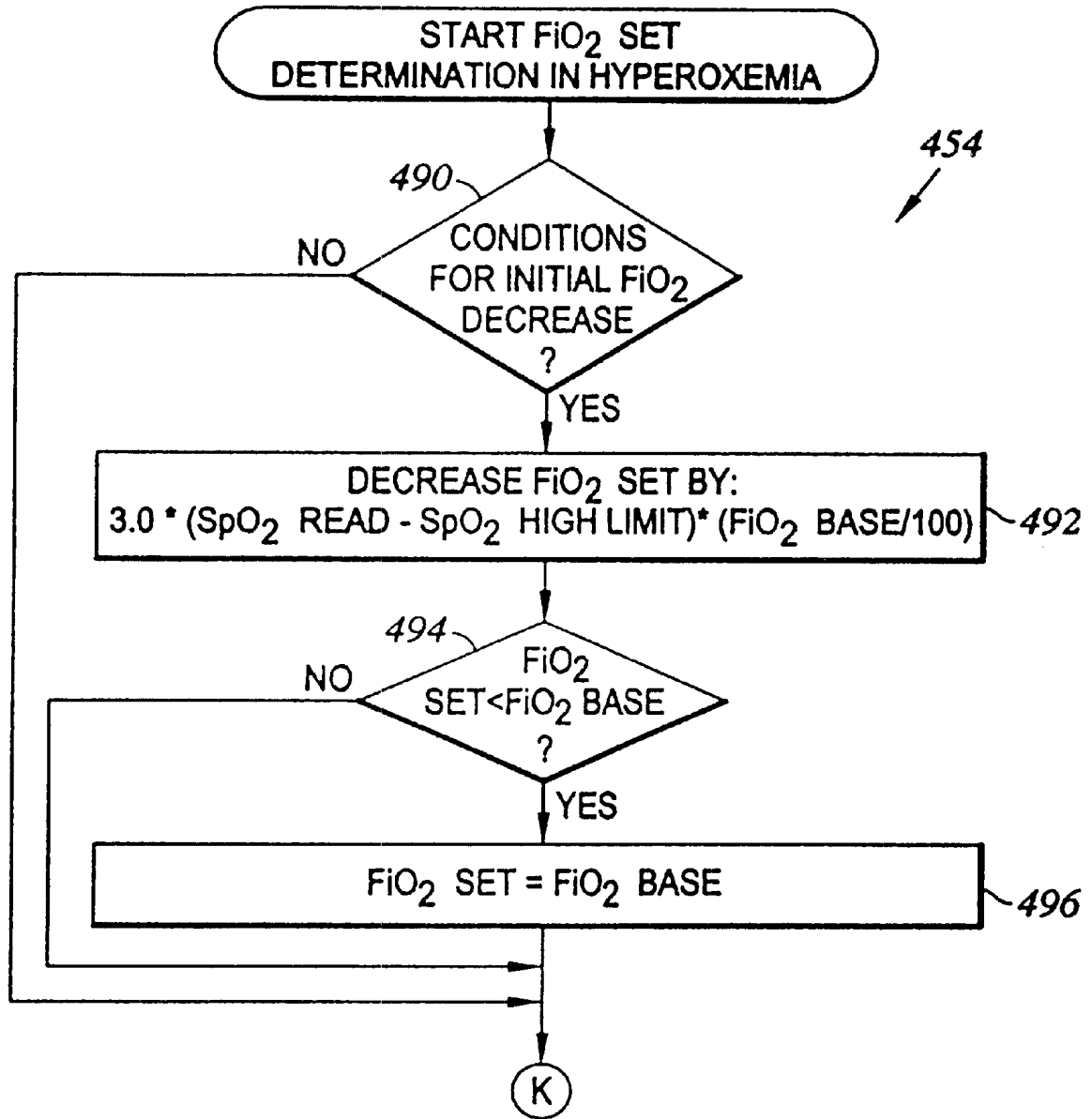

Fig. 16A

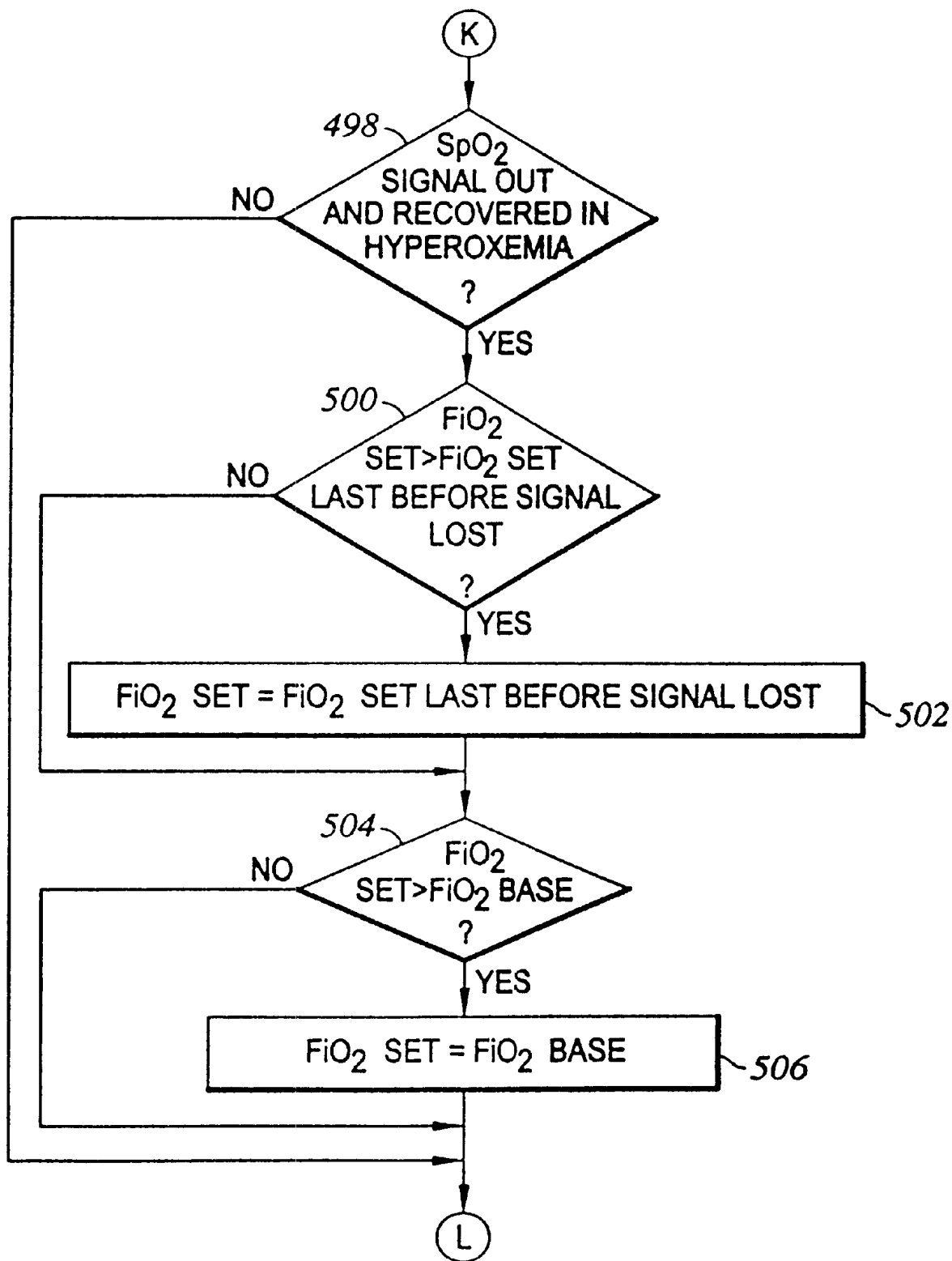

Fig. 16B

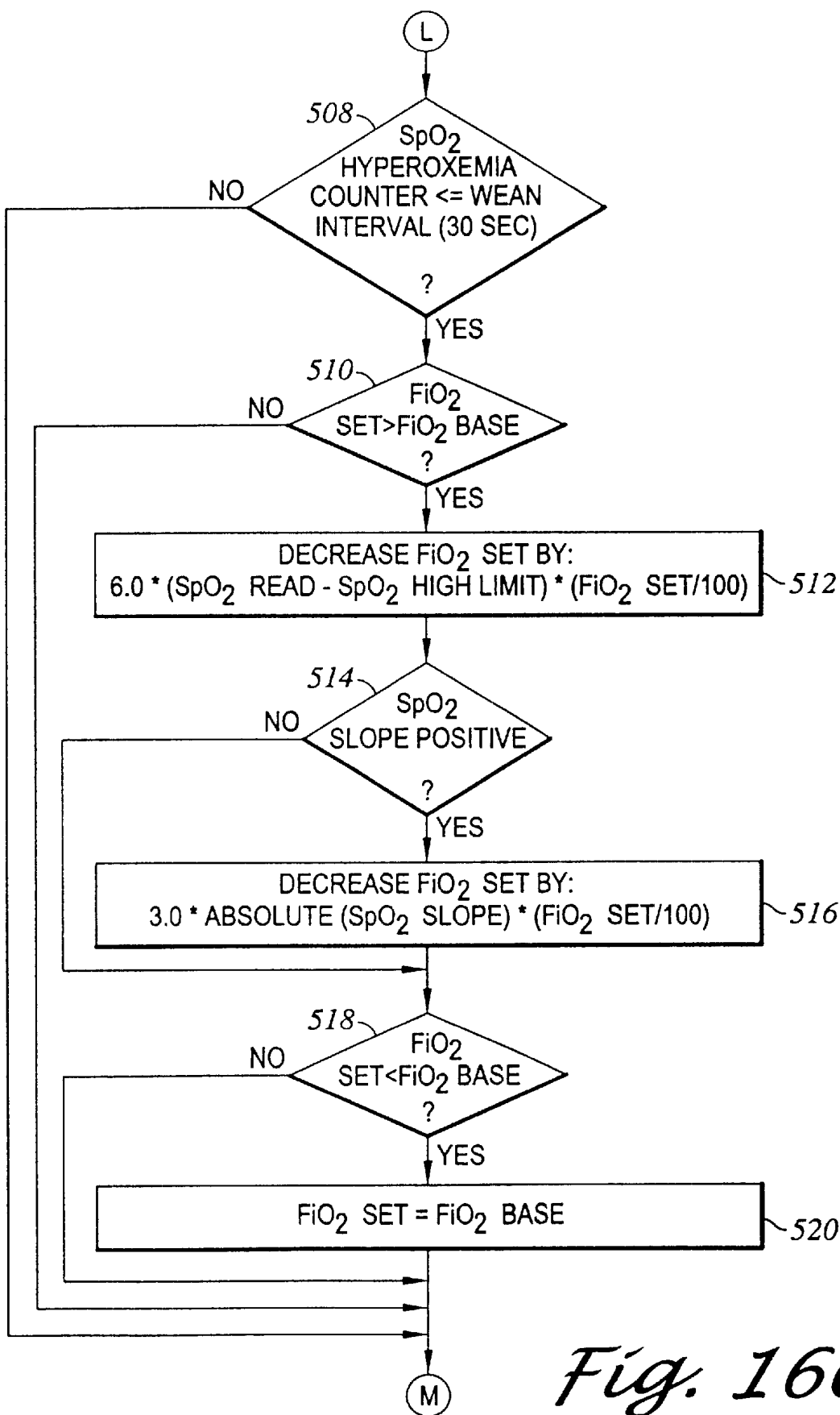

Fig. 16C

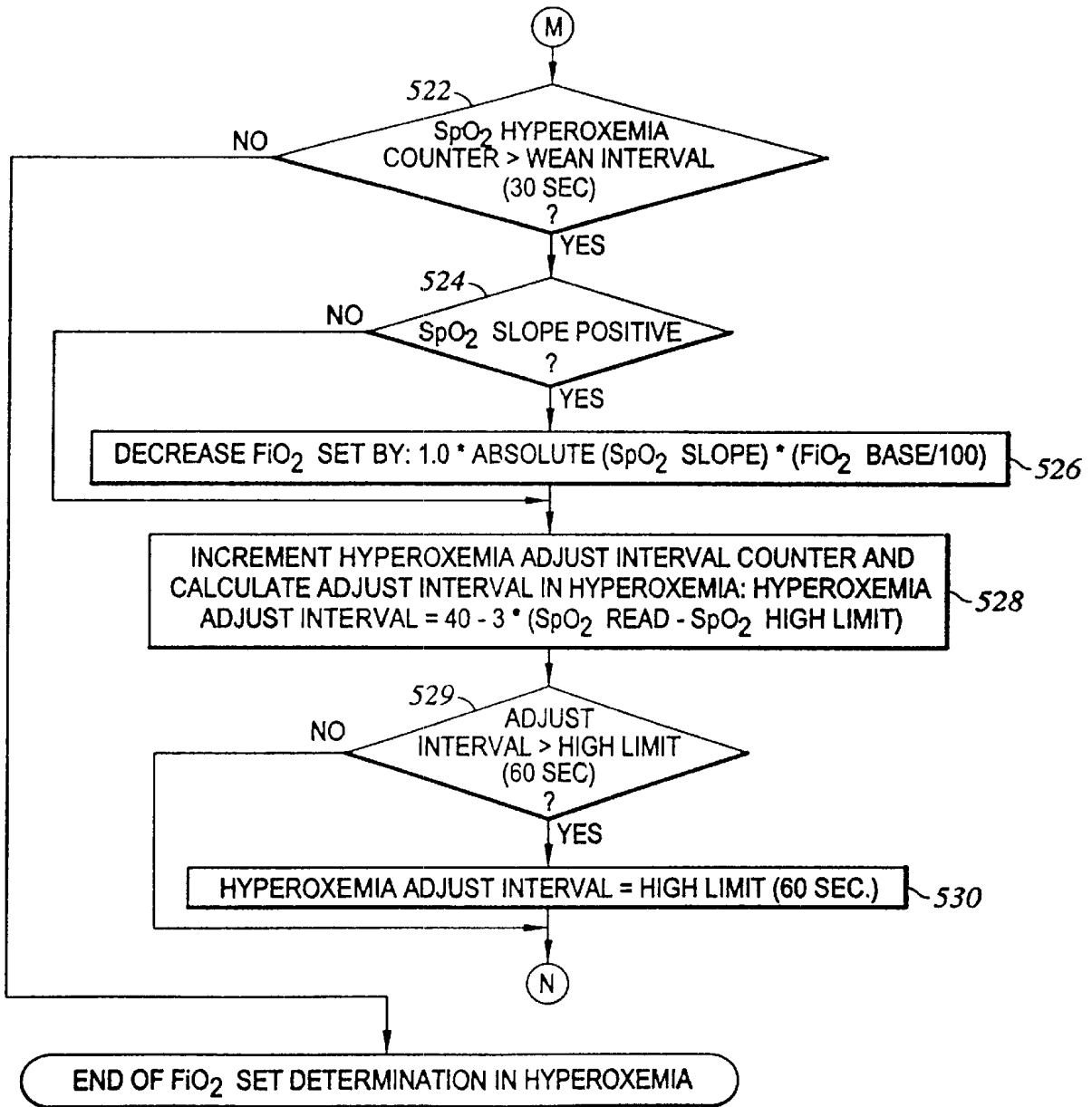

Fig. 16D

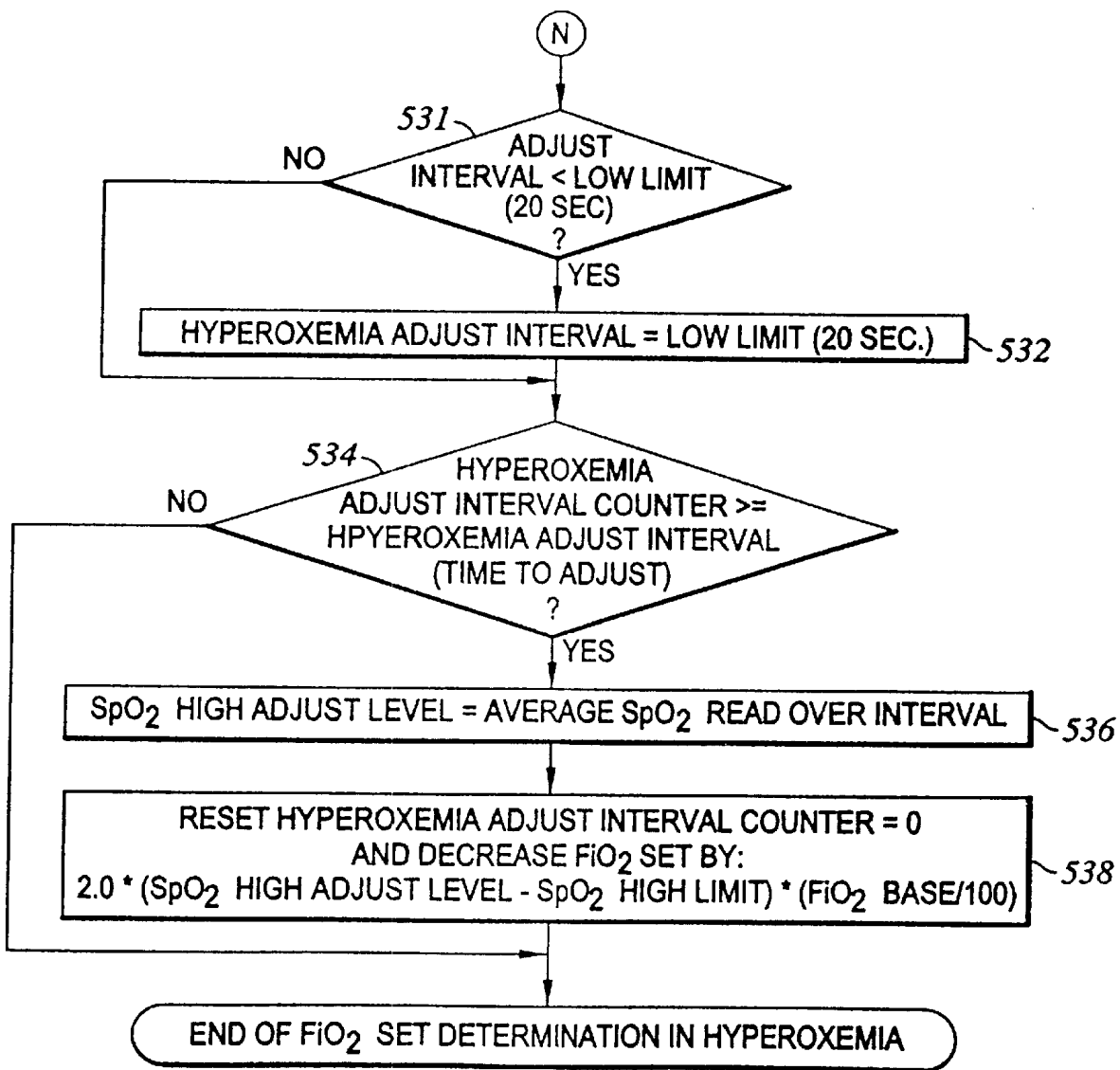

Fig. 16E

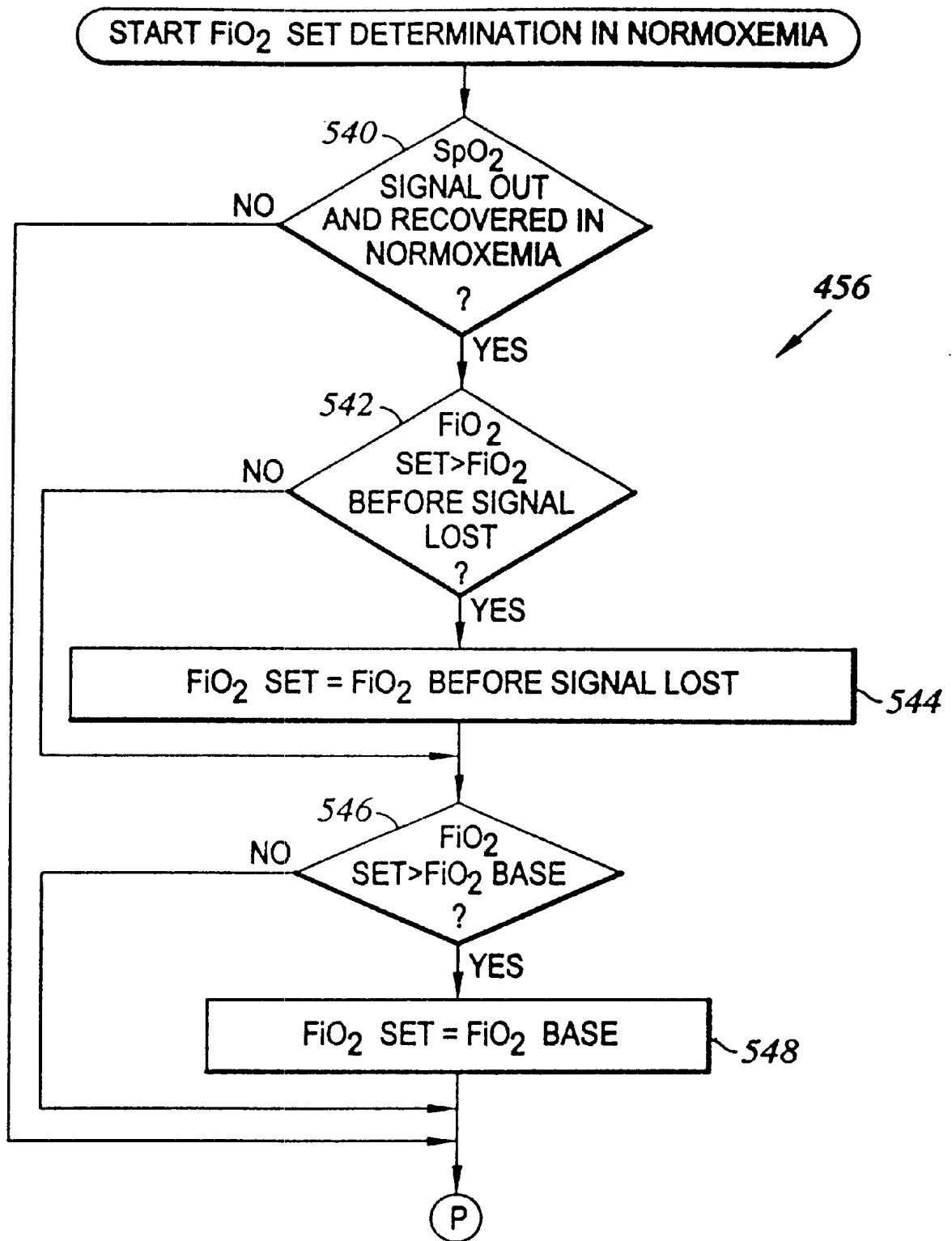

Fig. 17A

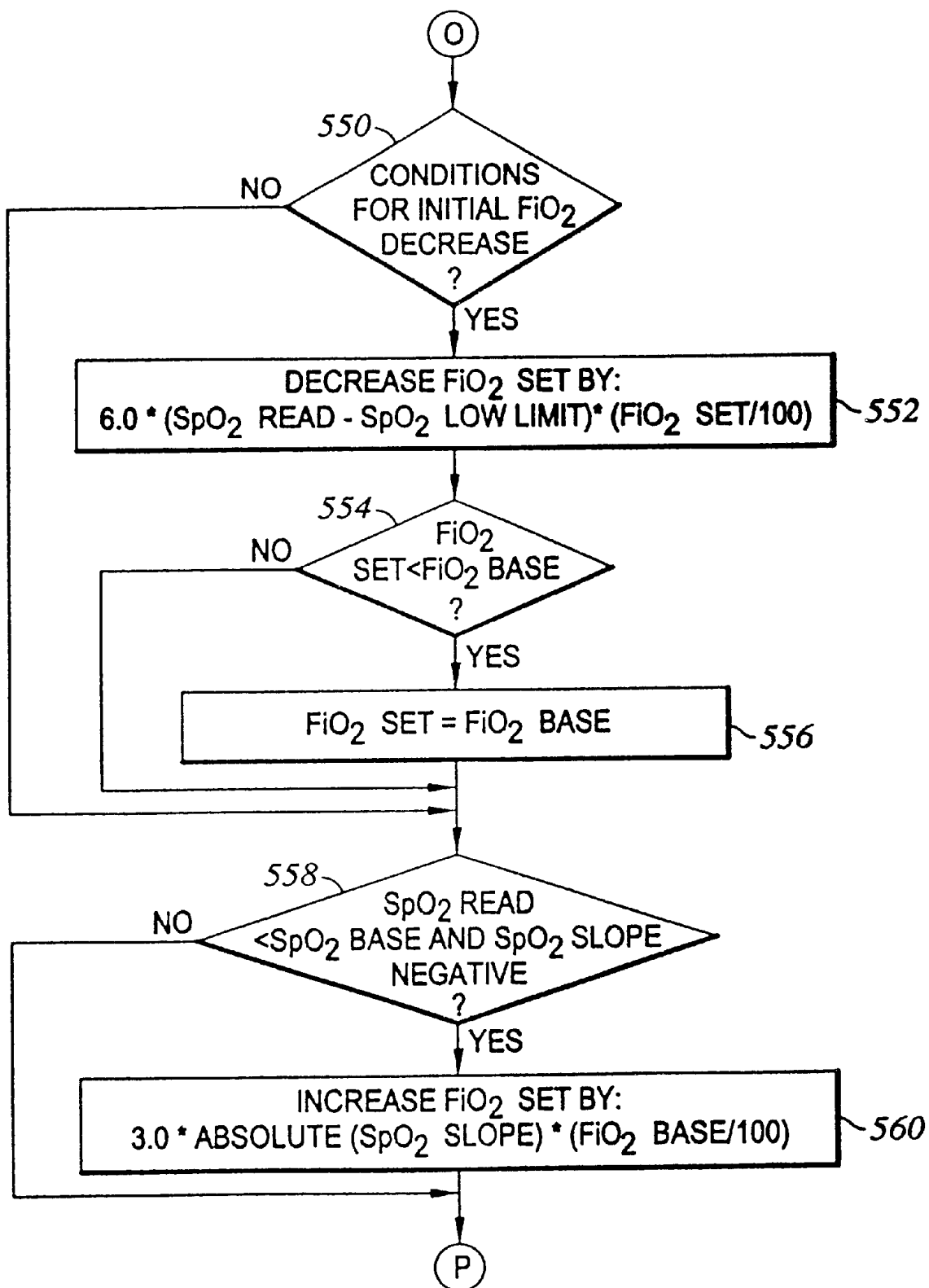

Fig. 17B

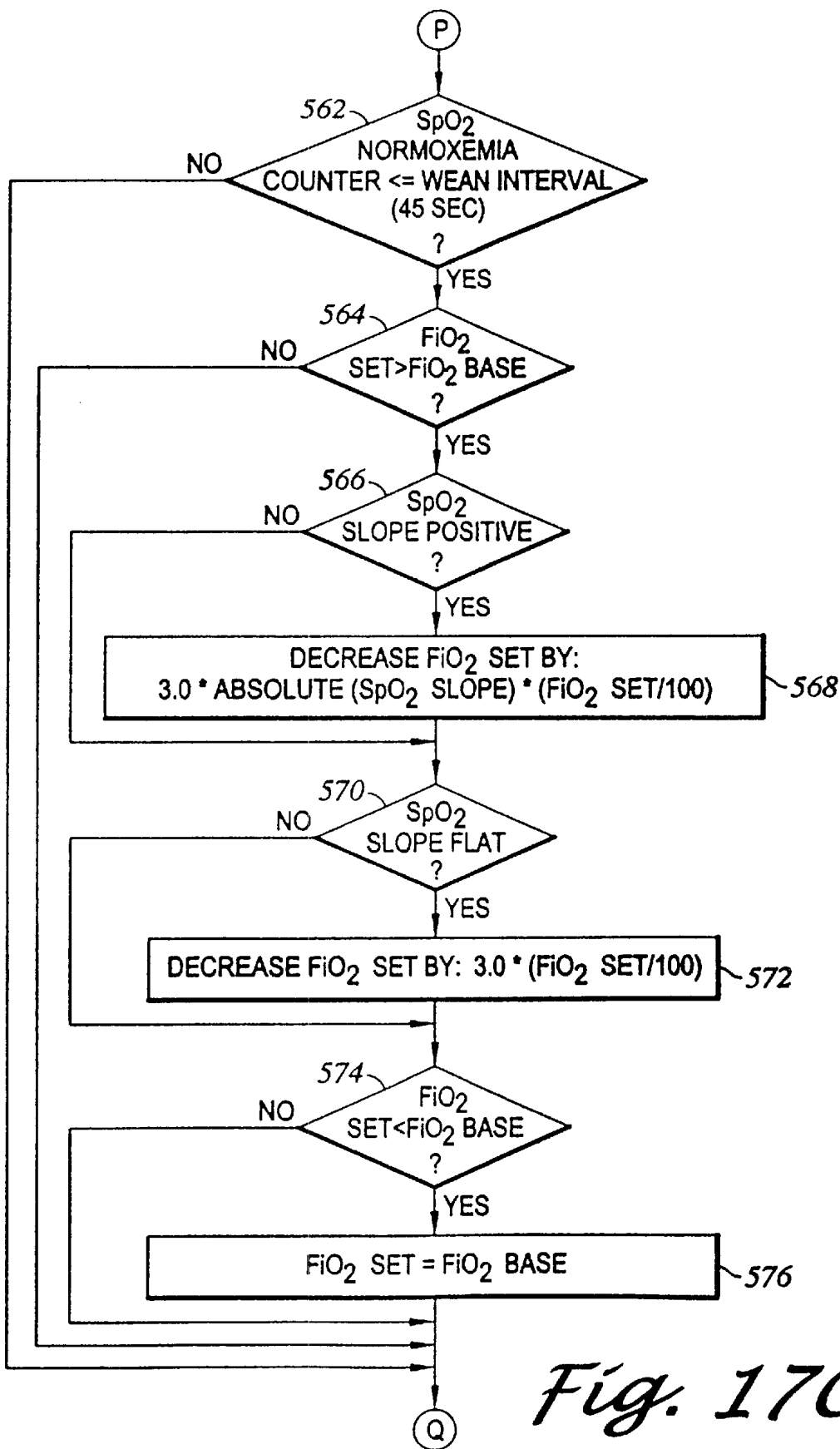

Fig. 17C

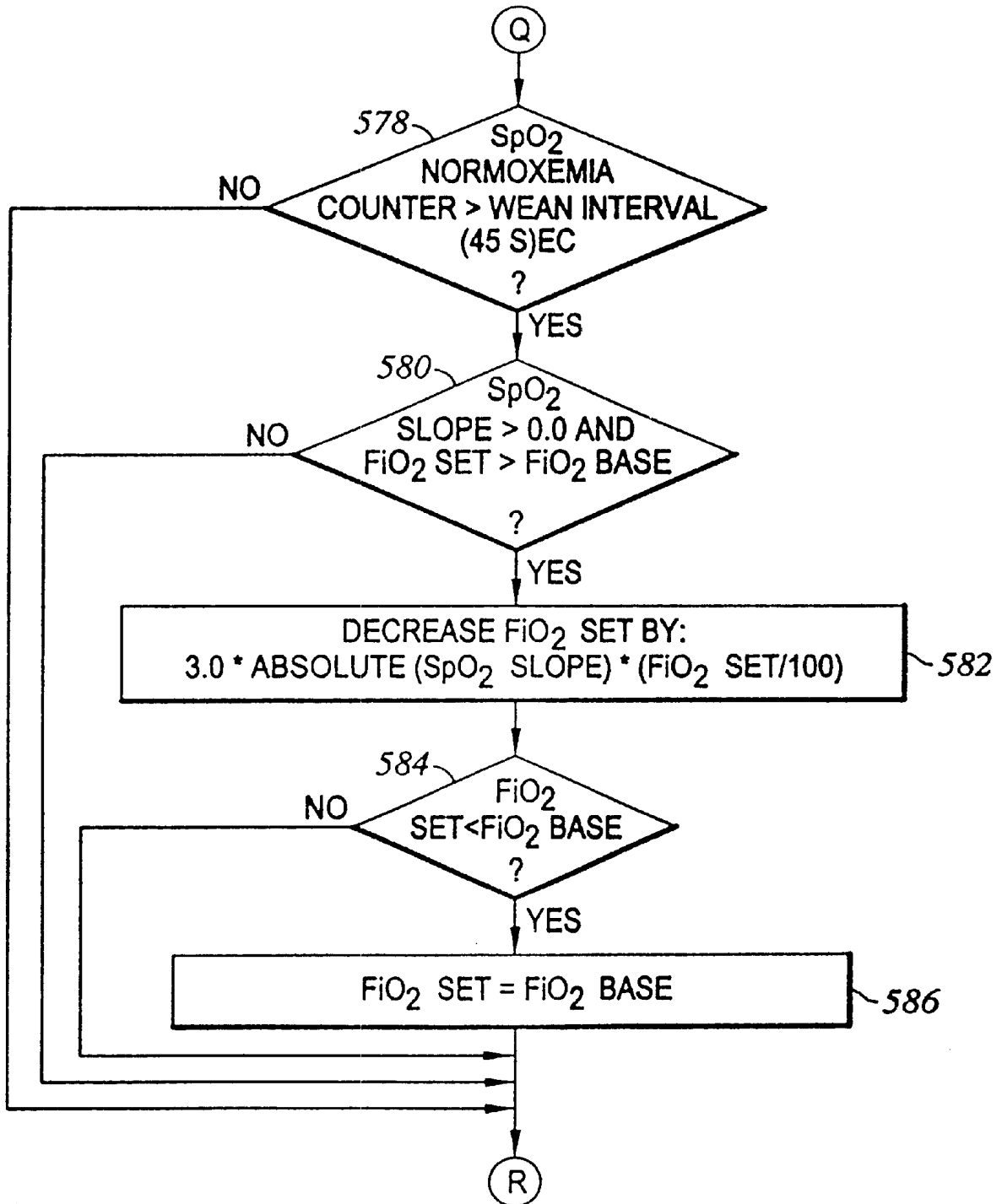

Fig. 17D

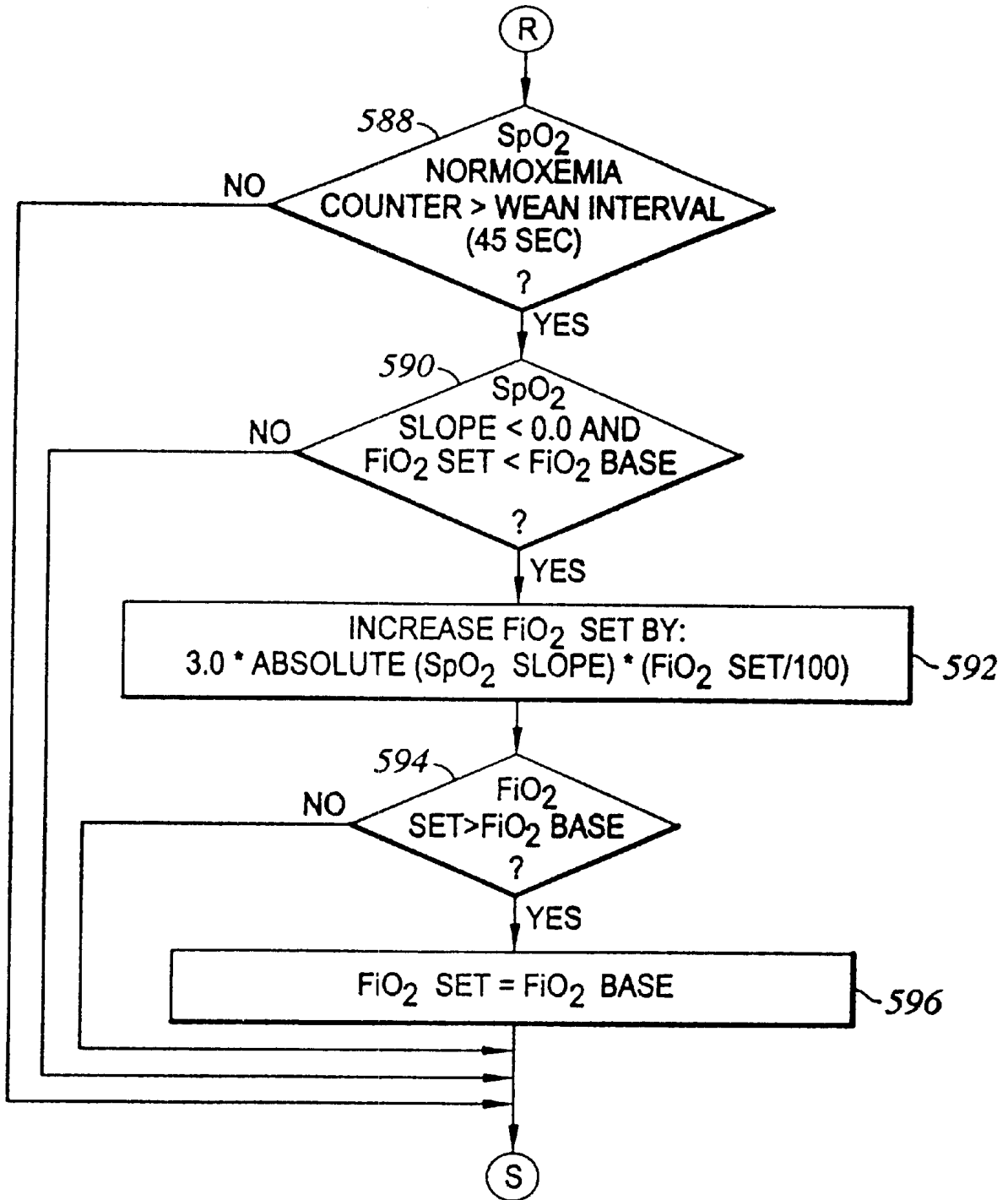

Fig. 17E

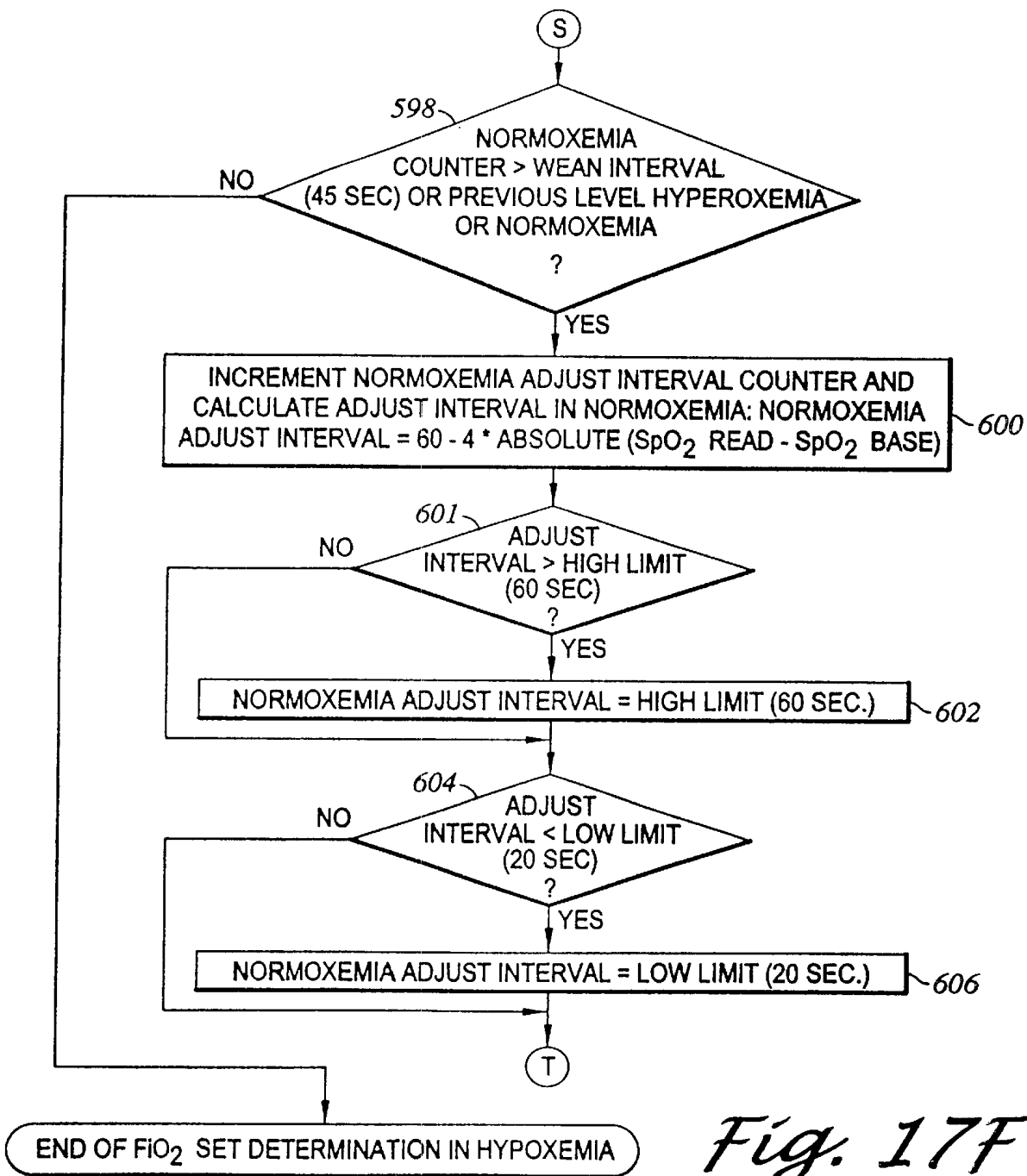
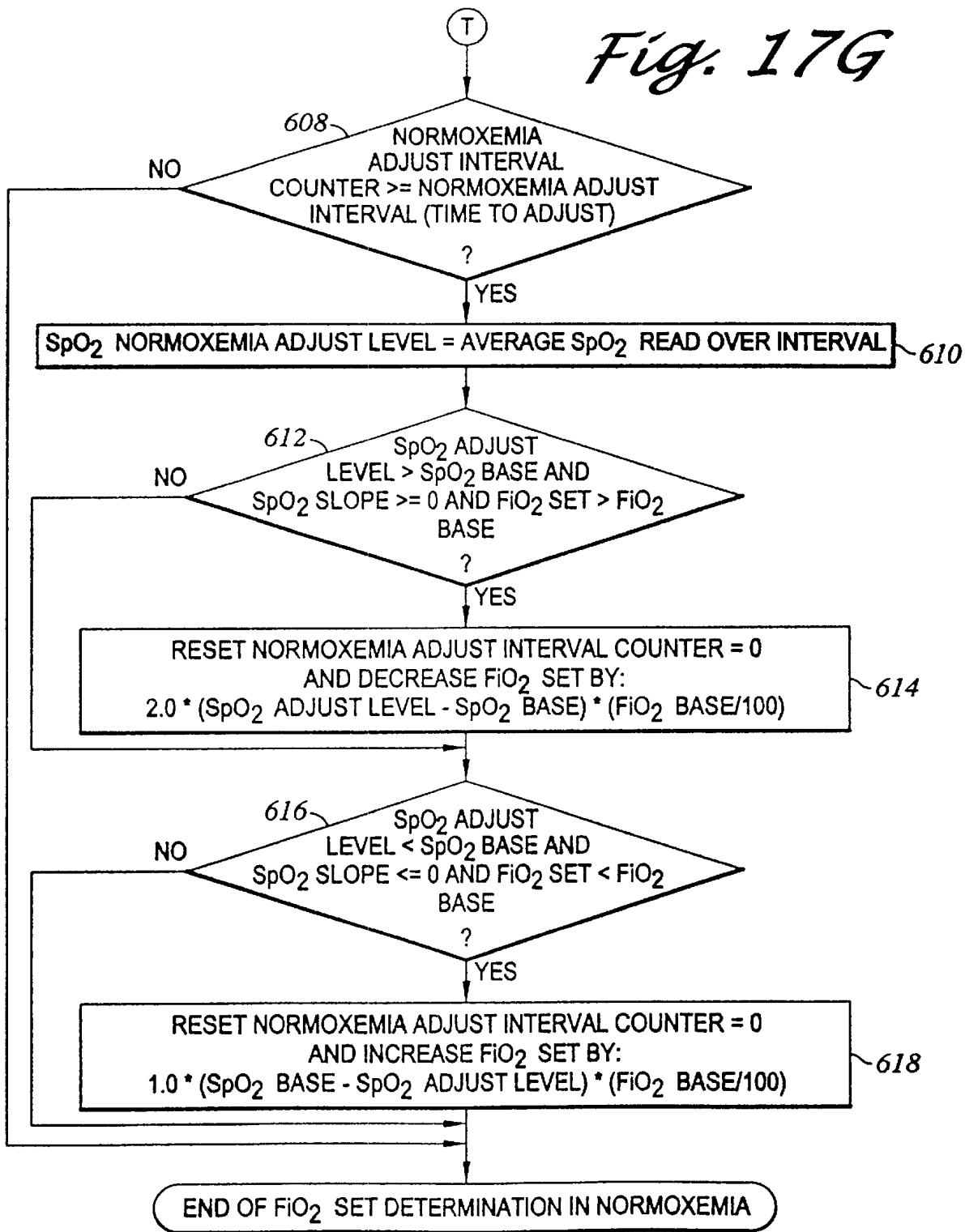

Fig. 17F

Fig. 17G



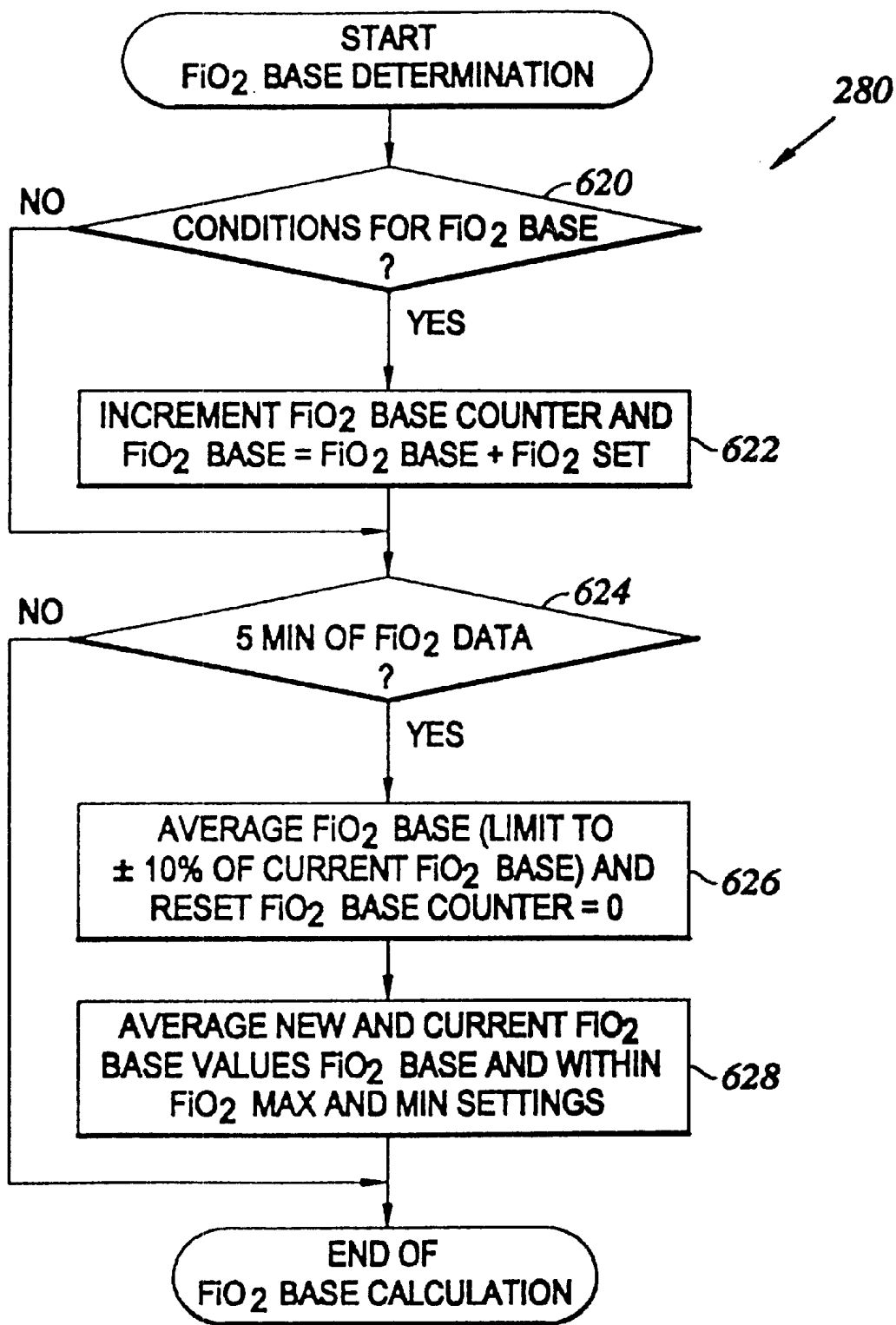

Fig. 18

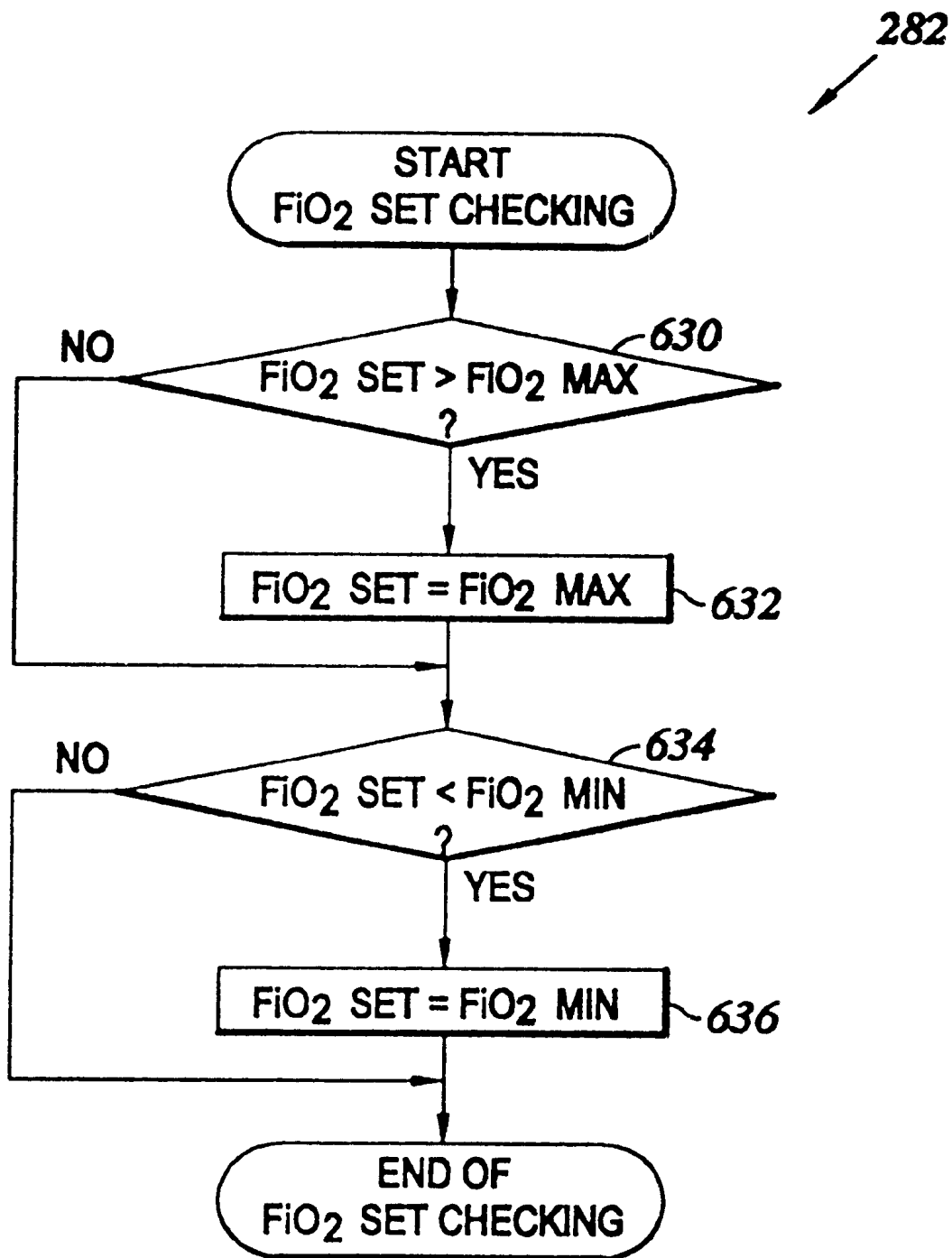

Fig. 19

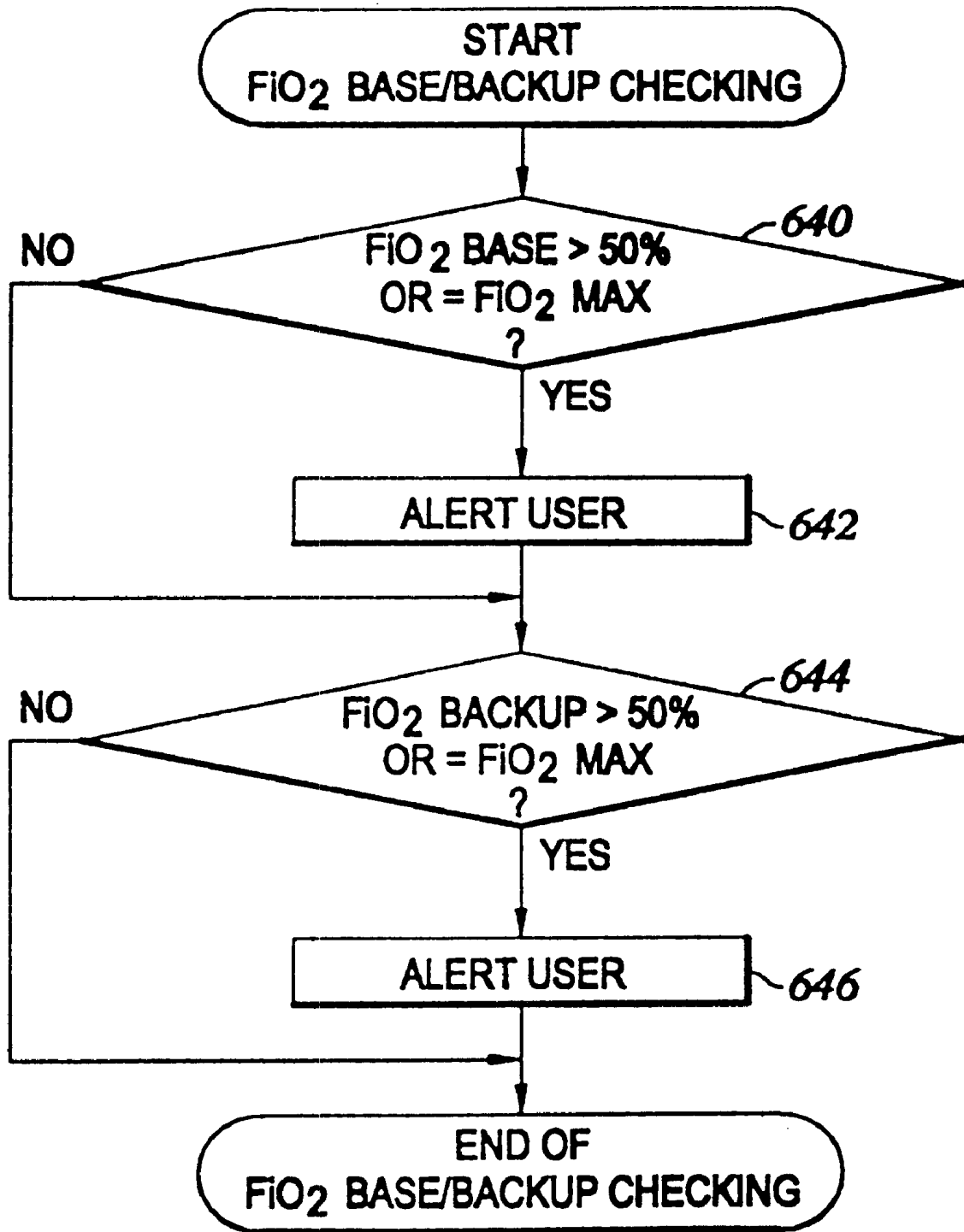
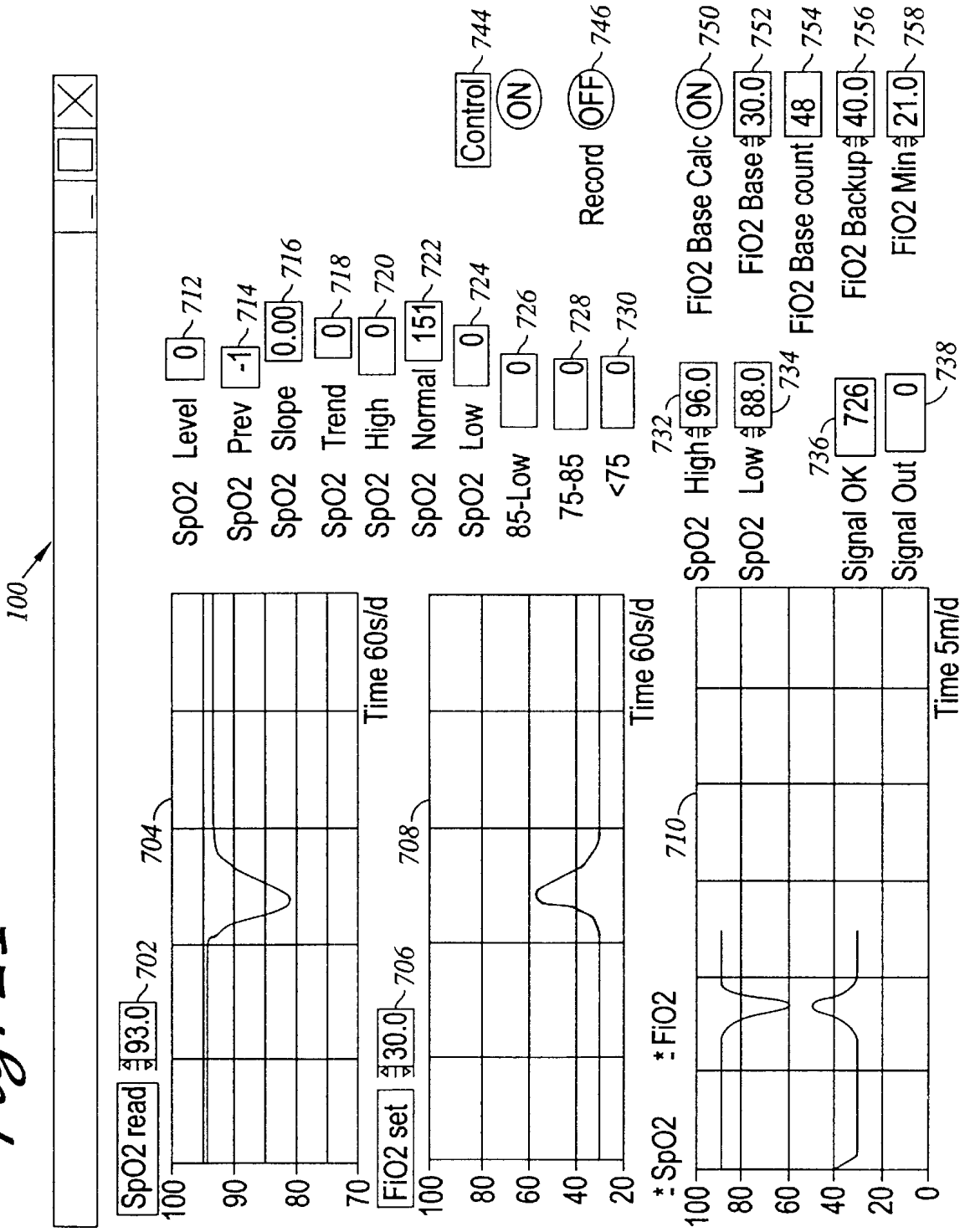

Fig. 20

Fig. 21



1

SYSTEM AND METHOD FOR CLOSED LOOP CONTROLLED INSPIRED OXYGEN CONCENTRATION

CROSS REFERENCE TO RELATED APPLICATIONS

This application is a division application of U.S. patent application Ser. No. 09/735,319 filed Dec. 12, 2000 now U.S. Pat. No. 6,512,938.

STATEMENT RE: FEDERALLY SPONSORED RESEARCH/DEVELOPMENT

(Not Applicable)

BACKGROUND OF THE INVENTION

The present invention relates generally to oxygen delivery systems and more particularly to a closed loop system and method for automatically delivering fractionally inspired oxygen (FiO_2).

Very low birth weight infants often present with episodes of hypoxemia. These episodes are detected by arterial oxygen saturation monitoring by pulse oximetry (SpO_2) and are usually assisted with a transient increase in the fraction of inspired oxygen (FiO_2).

Given the rapid onset and frequency at which most of these episodes of hypoxemia occur, maintaining SpO_2 within a normal range by manual FiO_2 adjustment during each episode is a difficult and time-consuming task. Nurses and respiratory therapists respond to high/low SpO_2 alarms. Under routine clinical conditions, the response time is variable and the FiO_2 adjustment is not well defined. This exposes the infants to periods of hypoxemia and hyperoxemia which may increase the risk of neonatal chronic lung disease and retinopathy of prematurity.

Thus, a need exists for a system that can automatically adjust FiO_2 . Prior art systems exist which automatically adjust FiO_2 . Such systems have had positive results. However, existing systems fail to respond to rapid SpO_2 changes and require manual intervention. Thus, a need exists for an automated system for adjusting FiO_2 which will respond to rapid SpO_2 changes. The system should not require manual intervention, but should allow for manual intervention, if desired. The system should also allow for gradually weaning the FiO_2 as soon as an episode begins to resolve.

BRIEF SUMMARY OF THE INVENTION

In accordance with the present invention, a system is provided for delivering fractionally inspired oxygen (FiO_2) to a patient. The system includes a device, such as a pulse oximeter, for obtaining an arterial hemoglobin oxygen saturation signal (SpO_2). An algorithm uses the SpO_2 to determine the appropriate FiO_2 to deliver to the patient. The algorithm adjusts the FiO_2 level of an air-oxygen mixer of an oxygen delivery device, such as a mechanical ventilator.

In accordance with other aspects of the invention, SpO_2 levels, including a target (normoxemia) range, are defined. SpO_2 values above the normoxemia range are considered to be hyperoxemic and values below the normoxemia range are considered to be hypoxemic.

In accordance with further aspects of the invention, a determination is made as to whether the SpO_2 signal is a valid signal. If the SpO_2 signal is not a valid signal, the FiO_2 to be delivered to the patient is determined based on a

2

backup value. If the SpO_2 signal is a valid signal and closed loop mode is not enabled, the FiO_2 to be delivered to the patient is determined based on a backup value. If the signal is valid and closed loop mode is enabled, the FiO_2 to be delivered to the patient is determined based on the current SpO_2 and the trend. The trend is determined by calculating a slope using previous SpO_2 values. The determined FiO_2 is then delivered to the patient, for example, using a ventilator or an air-oxygen gas mixer.

In accordance with still further aspects of the invention, a user interface is provided. The user interface displays status information. The user interface also displays alerts. The user interface can also be used to view and modify user settings/parameters.

BRIEF DESCRIPTION OF THE DRAWINGS

These, as well as other features of the present invention, will become more apparent upon reference to the drawings wherein:

FIG. 1 is a block diagram of a prior art system for manually adjusting the fraction of inspired oxygen (FiO_2);

FIG. 2 is a block diagram of a system for automatically adjusting FiO_2 in accordance with the present invention;

FIG. 3 is a flow diagram illustrating exemplary logic for automatically adjusting FiO_2 in accordance with the present invention;

FIG. 4 is a table of exemplary variables and defaults values used in the present invention;

FIG. 5 is a table of exemplary user settings and default values used in the present invention;

FIG. 6 is flow diagram illustrating exemplary logic for performing a control cycle as shown in FIG. 3;

FIG. 7 is a flow diagram illustrating exemplary logic for performing backup processing when a valid SpO_2 signal is not received as shown in FIG. 6;

FIGS. 8–20 are a flow diagram illustrating exemplary logic for processing a valid SpO_2 signal as shown in FIG. 6; and

FIG. 21 is an exemplary graphical user interface illustrating SpO_2 and FiO_2 values over a specified period of time.

DETAILED DESCRIPTION OF THE INVENTION

Traditionally, as shown in FIG. 1, a device, such as a pulse oximeter 50, is used to determine arterial hemoglobin oxygen saturation of a patient 60. A nurse 70 monitors the pulse oximeter 50. The nurse 70 adjusts the fractionally inspired oxygen (FiO_2) delivered to the patient 60 using a mechanical ventilator or air-oxygen mixer 80. Typically, ventilator device 80 mixes pure oxygen with air to give the patient a mixture of air having a percentage of oxygen. For example, a ventilator 80 may deliver a 90% oxygen/10% air mixture to the patient 60. The exact mixture of air required varies among patients and can vary for a given patient over a period of time. When a patient receives too much oxygen, a condition known as hyperoxemia occurs and if a patient does not receive enough oxygen, a condition known as hypoxemia occurs. "Normoxemia" occurs if the proper amount of oxygen is delivered (i.e., neither hyperoxemia nor hypoxemia occurs). A traditional system, such as the one shown in FIG. 1, is an "open system" because it requires human intervention (e.g., by a nurse 70).

As shown in FIG. 2, the present invention is a "closed system" which uses an algorithm 90 (described in detail

below) to deliver FiO_2 in response to receiving an arterial hemoglobin oxygen saturation signal (SpO_2). In exemplary embodiments of the invention, the algorithm acquires information on arterial oxygen-hemoglobin oxygen saturation (SpO_2) measured by a pulse oximeter **50** and uses this measurement as input to determine the adjustment required, if any, to the fractionally inspired oxygen concentration (FiO_2) delivered to a patient on a continuous basis via a ventilator **80**. It will be appreciated that the algorithm described herein can be applied to various modes of oxygen delivery, for example, mechanical ventilators, oxy-hood, nasal cannulas, and/or Continuous Positive Airway Pressure (CPAP) systems or incubators. The delay between the new FiO_2 setting and the actual oxygen concentration change is important. In most oxygen delivery modes the delay is relatively short (e.g., less than 15 seconds). However, there are significantly longer delays in large hoods or incubators. The closed-loop control system of the present invention is capable of changing the inspired gas concentration fast enough to follow rapid and frequent hypoxemic episodes. In exemplary embodiments of the present invention, SpO_2 is read from the analog output of a pulse oximeter. However, alternative embodiments allow for reading from other outputs, e.g., from any serial output.

Even though the invention does not require human intervention, manual adjustments and overrides can be performed. The system described herein is ideally suited for patients who are very low birth weight infants. However, it will be appreciated that the present invention is not so limited. The invention can be used for patients of all ages.

The present invention includes an algorithm **90** that continuously acquires the patient's SpO_2 information and adjusts the FiO_2 delivered to the patient (e.g., via a mechanical ventilator **80**) to maintain SpO_2 within a specific range set by a user (e.g., a nurse). In exemplary embodiments, the algorithm **90** calculates and adjusts the FiO_2 once per second on a "closed loop" basis using a direct electronic interface between the algorithm **90** and the ventilator's air-oxygen blender control.

The algorithm **90** defines SpO_2 ranges based on a user-defined target range of normoxemia. Hyperoxemia is assumed to occur when SpO_2 exceeds the normoxemia target range and hypoxemia is assumed to occur when SpO_2 falls below the normoxemia target range. The differential control feedback functions are used to deal with the patient variability changes in FiO_2 which in combination with the algorithm's rules modulate the magnitude and timing of FiO_2 adjustments during periods of normoxemia or during a hypoxemic or hyperoxemic episode. The factors used to determine the adjustments are the current SpO_2 level, direction and rate of SpO_2 change, degree and duration of the hypoxemic or hyperoxemic episode, current FiO_2 setting, and the individual patient's basal FiO_2 requirement during normoxemia.

FiO_2 adjustments during hyperoxemia and normoxemia are of smaller magnitude and slower pace than those occurring during hypoxemia. However, the rules and control functions in the algorithm are designed to enable the algorithm to modify its responses to changing conditions, from slow and subtle SpO_2 changes during periods of stability to rapidly falling SpO_2 during an acute period of hypoxemia.

The algorithm **90** also has a backup function in the event that there is missing SpO_2 information. The backup function locks the FiO_2 after a short wait period at a back-up level preset by the user or at the current FiO_2 level, whichever is higher until SpO_2 information is available again.

In addition to the standard pulse oximeter alarms, the algorithm alerts the user when an episode of hyperoxemia or hypoxemia occurs, when it lasts for more than a specified period of time (e.g., two minutes) in spite of FiO_2 adjustments, and when the adjustments set the FiO_2 at certain levels for example, a low level of 0.21 (room air) and a high level of 1.0 (pure oxygen). The user is also alerted when SpO_2 signal is lost. These alerts are intended to notify the user (e.g., nurse) to verify proper function of the SpO_2 measurement, FiO_2 delivery and communication links.

FIG. **3** is a flow diagram illustrating exemplary logic performed by algorithm **90**. The algorithm classifies SpO_2 according to ranges set by the user. The user sets a target range for normoxemia (e.g., an exemplary default range is 88%–96%). An SpO_2 above the range for normoxemia (e.g., greater than 96%) is considered hyperoxemic. An SpO_2 below the range for normoxemia (e.g., less than 88%) is considered hypoxemic. Because of its importance, hypoxemia is further subdivided. In exemplary embodiments, hypoxemia is further subdivided into the following ranges: less than 75%; 75–85%; and 85% to the low limit of the target range, (for example, using the exemplary default range, 85%–88%). FiO_2 is adjusted based on the current SpO_2 , the SpO_2 trend and the time that SpO_2 has been within the range, as well as basal and current FiO_2 settings.

The logic of FIG. **3** moves from a start block to block **100** where system defaults are set. Various system defaults or parameters, such as those shown in the table of FIG. **4** are preset. The parameters (variables) in Table 4 are described in further detail later. These variables can be modified by the application and/or by the user.

After system defaults are set, the logic of FIG. **3** moves to block **102** where a user interface is displayed. An exemplary user interface is illustrated in FIG. **21** and described later.

The logic of FIG. **3** then moves to block **104** where user settings are read. User settings, such as those shown in FIG. **5**, should be set prior to commencement of the closed loop execution (i.e., prior to entering the control cycle). Preferably, the settings can also be set or modified during execution of the algorithm. Preferably, a suitable user interface (such as the one shown in FIG. **21**) is provided to allow the user to set/modify these values. Although the user can set/modify these values, preferably system defaults (such as those shown in FIG. **5**) are provided.

In exemplary embodiments of the invention SpO_2 Target Range High Limit and SpO_2 Target Range Low Limit define the patient's desired target range. In the exemplary embodiment shown in FIG. **5**, SpO_2 Target Range Low Limit must be in the range between 85%–94% and has a default value of 88% and SpO_2 Target Range High Limit must be in the range between 94%–100% and has a default value of 96%. Thus, the default target range is 88%–96%.

FiO_2 Base is the patient's basal oxygen requirement to maintain normal SpO_2 . FiO_2 Base can be kept fixed at the user setting or automatically adjusted by the algorithm to changes in the basal oxygen needs. FiO_2 Base is also the initial level for FiO_2 Set when closed loop is switched ON. The default setting for FiO_2 Base can alternatively be obtained from the user setting during manual (normal) mode used before closed loop is ON. In the exemplary embodiment shown in FIG. **5**, FiO_2 Base must be in the range between 21%–60% and has a default value of 30%.

FiO_2 Backup is the default value for FiO_2 Set when the system is started, when SpO_2 Signal is OUT or when closed-loop switch is OFF. FiO_2 Backup should not be lower than the basal (FiO_2 Base). In the exemplary embodiment

shown in FIG. 5, FiO₂ Backup must be in the range between 21%–100% and has a default value of 40%.

FiO₂ Min is the minimum level at which FiO₂ Set, FiO₂ Base and FiO₂ Backup can be set. In the exemplary embodiment shown in FIG. 5, FiO₂ Min has a default value of 21% (room air).

FiO₂ Max (not shown in FIG. 5) is a default parameter. For example, FiO₂ Max is initially set at a default of 100% (pure oxygen), but can be user selectable.

After the user settings are read, the logic of FIG. 3 proceeds to block 106 where a control cycle is performed as shown in FIG. 6 and described in detail next. The control cycle is initiated when the user switches closed-loop to ON. If closed-loop is set to OFF, the control cycle loop continues, but FiO₂ Set is returned to the FiO₂ Backup level. FiO₂ Set is the actual parameter set at the air-oxygen mixer.

FIG. 6 is a flow diagram illustrating exemplary logic for performing a control cycle in accordance with the present invention. The logic moves from a start block to block 200 where SpO₂ (e.g., SpO₂ output signal from pulse oximeter 50) is read. The SpO₂ that is read is stored as SpO₂ Read. Next, the logic moves to decision block 202 where a test is made to determine if SpO₂ Read is within the acceptable SpO₂ range. For example, as shown in FIG. 4, in exemplary embodiments, the default range is between 20 and 100%. If SpO₂ Read is not within the acceptable range (no in decision block 202), the logic moves to block 204 where SpO₂ signal OUT processing is performed as shown in FIG. 7 and described below. Most oximeters provide a 0% reading when signal is OUT when communication between the oximeter and algorithm is by means of the analog output of the pulse oximeter. Alternatively, if serial communication exists between the oximeter and the algorithm, SpO₂ information can be monitored by proper communication handshake. If SpO₂ is within the SpO₂ OK range (yes in decision block 202), the logic moves to block 206 where SpO₂ Signal OK processing is performed as shown in detail in FIG. 8 and described later. After SpO₂ signal OUT processing has been performed (block 204) or SpO₂ OK processing has been performed (block 206), the logic moves to block 208 to monitor whether user settings have been changed. Preferably, the user can change various settings at any time. If user settings have been changed, variables are updated accordingly. The logic then returns to block 200 where SpO₂ is read and processed again. In exemplary embodiments, SpO₂ is read and processed (e.g., FiO₂ adjusted accordingly) every second. Thus, the SpO₂ is continuously monitored every second until the system is shut off.

FIG. 7 illustrates exemplary logic for performing SpO₂ Signal OUT (e.g., backup mode) processing in accordance with the present invention. In backup mode processing, FiO₂ Set (i.e., the actual parameter set at the air-oxygen mixer) is locked at the FiO₂ Backup level, at the FiO₂ Base level or at the current level (whichever is higher) until feedback information is available again.

The logic of FIG. 7 moves from a start block to block 220 where the user is alerted and the cause is checked. There are various reason why a pulse oximeter may fail to provide information, for example, poor signal quality during motion or low perfusion (or both), a loose probe or a probe no longer in place, or a break on the communication link between the oximeter and the algorithm 90. Next, the logic moves to block 222 where SpO₂ Out Counter is incremented. SpO₂ Out Counter is used to confirm that signal loss is not related to some type of temporary variability or error. Only after a minimum interval has passed is SpO₂ Signal OK Counter

reset. This allows activities to resume normally if there was a short drop-out period. Next, the logic moves to decision block 224 where a test is made to determine if SpO₂ Out Counter is equal to SpO₂ Time to Zero Counters. If so, the logic moves to block 226 where SpO₂ OK Counter is set to zero. For example, in the exemplary embodiment shown in FIG. 4, the default value is ten seconds. Thus, if SpO₂ Out Counter is equal to ten, SpO₂ OK Counter will be reset to zero. The illustrated embodiment assumes that SpO₂ is read and processed once a second. However, it will be appreciated that the algorithm can be modified to accommodate reading and processing SpO₂ values at a different interval.

Next, the logic moves to decision block 228 where a test is made to determine if SpO₂ Out Counter has been set for the last five seconds (e.g., SpO₂ Out Counter is greater than or equal to five). While the logic illustrated is based on a lost SpO₂ signal for five consecutive seconds, it will be appreciated that other time periods can be used. Preferably, the default value can be modified by the user. A short wait will provide early additional oxygen if hypoxemia is accompanied by motion of the extremities (which is often observed), whereas a longer wait will generally apply to cases where hypoxemia is not frequent and signal loss is not accompanied by hypoxemia. If SpO₂ has not been set for the specified period of time (e.g., five seconds), the logic of FIG. 7 ends.

If, however, SpO₂ has been lost (OUT) for the last five seconds or other specified period of time (yes in decision block 228), the logic moves to block 230 where FiO₂ Set Last Before Signal Lost is set to FiO₂ Set. When FiO₂ is set to the backup level, the algorithm stores the last FiO₂ value in memory. This FiO₂ Set Last Before Signal Lost value is used under some conditions to set FiO₂ as soon as SpO₂ is available again. Next, the logic moves to decision block 232 where a test is made to determine if FiO₂ Backup is greater than or equal to FiO₂ Base. If so, the logic moves to decision block 234 where a test is made to determine if FiO₂ Set is less than FiO₂ Backup. If so, the logic moves to block 236 where FiO₂ Set is set to FiO₂ Backup. The logic of FIG. 7 then ends and processing returns to FIG. 6.

If FiO₂ Backup is less than FiO₂ Base (no in decision block 232), the logic moves to decision block 238 where a test is made to determine if FiO₂ Set is less than FiO₂ Base. If so, the logic moves to block 240 where FiO₂ Set is set to FiO₂ Base. If not, FiO₂ set does not get changed. The logic of FIG. 7 then ends and processing returns to FIG. 6.

FIG. 8 illustrates exemplary logic for performing SpO₂ Signal OK processing in accordance with the present invention. The counters of time spent with SpO₂ within each range are updated continuously. These counters are used to classify and confirm the actual SpO₂ level (normoxemia, hyperoxemia or hypoxemia) and discriminate against short variability. Only after a minimum time has elapsed since SpO₂ has reached any specific range is it considered to be a new SpO₂ level. In the exemplary embodiment illustrated in FIG. 4, the default time period before being considered a new level defaults to three seconds (SpO₂ Time in High Norm Low Range Min). This short interval can be affected by short variability, therefore, other counters for previous SpO₂ ranges are reset only after a longer interval (SpO₂ Time to Zero Counters, which defaults to ten seconds in the exemplary embodiment shown in FIG. 4) has elapsed. In this way, SpO₂ Read is confirmed to be out of any specific range only after the longer time period (e.g., ten seconds) SpO₂ Read is confirmed to be in the new range after three seconds (or whatever value SpO₂ Time in High Norm Low Range Min is set to) but it is confirmed to be out of the previous range only after ten seconds (or whatever value Time to Zero

Counters is set to). In this way, if SpO₂ Read returns shortly after to the previous range, all activities in that range will resume immediately.

The logic of FIG. 8 moves from a start block to block 250 where SpO₂ OK Counter is incremented. Next, the logic moves to decision block 252 where a test is made to determine if SpO₂ OK Counter is equal to SpO₂ Time to Zero Counters. If so, the logic moves to block 254 where SpO₂ Out Counter is set to zero. Next, appropriate timing processing is performed based on SpO₂ Read. If SpO₂ Read is in the target range for normoxemia, for example, 88%–96%, (yes in decision block 256), the logic moves to block 258 where normoxemia timing is performed as shown in detail in FIG. 9 and described next.

FIG. 9 illustrates exemplary logic for performing normoxemia timing in accordance with the present invention. As shown in FIG. 9, and described below, normoxemia is considered the new SpO₂ level only after a specified period of time (e.g., three seconds) has elapsed since SpO₂ entered the target range, however, counters for other SpO₂ ranges are reset only after a longer interval (e.g., ten seconds) has elapsed. The logic of FIG. 9 moves from a start block to block 300 where SpO₂ Normoxemia Counter is incremented. Next, the logic moves to decision block 302 where a test is made to determine if SpO₂ Normoxemia Counter is greater than or equal to SpO₂ Min Time in Range (SpO₂ Time in High Norm Low Range, e.g., three seconds). If so, the logic moves to decision block 304 where a test is made to determine if SpO₂ Normoxemia Counter is equal to SpO₂ Min Time in Range. If so, the logic moves to block 306 where SpO₂ Previous Level is set to SpO₂ Level. Regardless of the outcome of decision block 304, the logic proceeds to block 308 where SpO₂ Level is set to Normoxemia. Regardless of the outcome of decision block 302, the logic moves to decision block 310 where a test is made to determine if SpO₂ Normoxemia Counter is greater than SpO₂ Time to Zero Counters. If so, the logic moves to block 312 where counters (SpO₂ Hyperoxemia Counter, SpO₂ Hypoxemia Counter, SpO₂ Hypoxemia 85-Low Limit Counter, SpO₂ Hypoxemia 75–85 Counter and SpO₂ Hypoxemia less than 75 Counter) are set to zero. The logic of FIG. 9 then ends and processing returns to FIG. 8.

Returning to FIG. 8, if SpO₂ Read is greater than the target range (yes in decision block 260), the logic moves to block 262 where hyperoxemia timing is performed as shown in detail in FIG. 10 and described next.

FIG. 10 illustrates exemplary logic for performing hyperoxemia timing in accordance with the present invention. As shown in FIG. 10 and described below, hyperoxemia is considered the new SpO₂ level only after a specified period of time (e.g., three seconds) has elapsed since SpO₂ entered the hyperoxemia range, however, counters for other SpO₂ ranges are reset only after a longer interval (e.g., ten seconds) has elapsed. The logic of FIG. 10 moves from a start block to block 320 where SpO₂ Hyperoxemia Counter is incremented. Next, the logic moves to decision block 322 where a test is made to determine if SpO₂ Hyperoxemia Counter is greater than or equal to SpO₂ Min Time in Range. If so, the logic moves to decision block 324 where a test is made to determine if SpO₂ Hyperoxemia Counter is equal to the SpO₂ Min Time in Range. If so, the logic moves to block 326 where SpO₂ Previous Level is set to SpO₂ Level. Regardless of the outcome of decision block 324, the logic proceeds to block 328 where SpO₂ Level is set to Hyperoxemia. Regardless of the outcome of decision block 322, the logic moves to decision block 330 where a test is made to determine if SpO₂ Hyperoxemia Counter is greater than

SpO₂ Time to Zero Counters. If so, the logic moves to block 332 where counters (SpO₂ Normoxemia Counter, SpO₂ Hypoxemia Counter, SpO₂ Hypoxemia 85-Low Limit Counter, SpO₂ Hypoxemia 75–85 Counter and SpO₂ Hypoxemia less than 75 Counter) are set to zero. The logic of FIG. 10 then ends and processing returns to FIG. 8.

Returning to FIG. 8, if SpO₂ Read is less than the target range (yes in decision block 264), the logic moves to block 266 where hypoxemia timing is performed as shown in detail in FIG. 11 and described next.

FIG. 11 illustrates exemplary logic for performing hypoxemia timing in accordance with the present invention. As shown in FIG. 11, and described below, hypoxemia is considered the new SpO₂ level only after a specified period of time (e.g., three seconds) has elapsed since SpO₂ entered the hypoxemia range, however, counters for other SpO₂ ranges are reset only after a longer interval (e.g., ten seconds) has elapsed. The logic of FIG. 11 moves from a start block to block 340 where SpO₂ Hypoxemia Counter is incremented. Next, the logic moves to decision block 342 where a test is made to determine if SpO₂ Hypoxemia Counter is greater than or equal to SpO₂ Min Time in Range. If so, the logic moves to decision block 344 where a test is made to determine if SpO₂ Hypoxemia Counter is equal to SpO₂ Min Time in Range. If so, the logic moves to block 346 where SpO₂ Previous Level is set to SpO₂ Level. Regardless of the outcome of decision block 344, the logic proceeds to block 348 where SpO₂ Level is set to Hypoxemia. Regardless of the outcome of decision block 342, the logic of FIG. 11 proceeds to decision block 350 where a test is made to determine if SpO₂ Hypoxemia Counter is greater than SpO₂ Time to Zero Counters. If so, the logic moves to block 352 where counters (SpO₂ Normoxemia Counter and SpO₂ Hyperoxemia Counter) are set to zero.

As described above, hypoxemia is subdivided into ranges, for example, less than 75%, 75%–85% and 85% to the low limit for normoxemia. Hypoxemia counters for the various sub-ranges are set based on SpO₂ Read, as appropriate. If SpO₂ Read is between 85 and SpO₂ Target Range Low Limit, for example, using the exemplary default range, between 85%–88%, (yes in decision block 354), the logic moves to block 356 where SpO₂ Hypoxemia 85-Low Limit Counter is incremented. The logic then moves to decision block 358 where a test is made to determine if SpO₂ Hypoxemia 85-Low Limit Counter is greater than Time to Zero Counters. If so, the logic moves to block 360 where counters (SpO₂ Hypoxemia 75–85 Counter and SpO₂ Hypoxemia less than 75 Counter) are set to zero. If SpO₂ Read is between 75 and 85 (yes in decision block 362), the logic moves to block 364 where SpO₂ Hypoxemia 75–85 Counter is incremented. The logic then moves to decision block 366 where a test is made to determine if SpO₂ Hypoxemia 75–85 Counter is greater than SpO₂ Time to Zero Counters. If so, the logic moves to block 368 where counters (SpO₂ Hypoxemia 85-Low Limit Counter and SpO₂ Hypoxemia less than 75 Counter) are set to zero. If SpO₂ Read is less than 75 (yes in decision block 370), the logic moves to block 372 where SpO₂ Hypoxemia less than 75 Counter is incremented. The logic then proceeds to decision block 374 where a test is made to determine if SpO₂ Hypoxemia less than 75 Counter is greater than SpO₂ Time to Zero Counters. If so, the logic moves to block 376 where counters (SpO₂ Hypoxemia 85-Low Limit Counter and SpO₂ Hypoxemia 75–85 Counter) are set to zero. The logic of FIG. 11 then ends and processing returns to FIG. 8.

Returning to FIG. 8, after appropriate timing processing has been performed (e.g., normoxemia timing in block 258,

hyperoxemia timing in block 262 or hypoxemia in block 266), the logic of FIG. 8 moves to block 268 where the SpO₂ slope calculation is performed as illustrated in detail in FIG. 12 and described next.

FIG. 12 illustrates exemplary logic for performing the SpO₂ slope calculation in accordance with the present invention. Since SpO₂ is read and processed every second, the slope is calculated every second. When a slope is calculated, it is calculated based on the current SpO₂ reading and the previous seven consecutive SpO₂ readings. It will be appreciated that a value other than seven may be used for the number of previous values to use when calculating the slope. All of the readings used in calculating the slope should be within the range where SpO₂ signal is considered OK. The slope is the average of the second-to-second SpO₂ change. The calculated slope is limited to a specified range. For example, in the illustrated embodiment shown in FIG. 4, the range defaults to +/-5% per second (SpO₂ Slope High Limit and SpO₂ Slope Low Limit). In various embodiments, multiple slopes can be calculated to track fast, medium, and slow changes simultaneously. The multiple slopes can then be used at different times within the FiO₂ Set Determination procedure (shown in FIG. 14).

The logic of FIG. 12 moves from a start block to decision block 380 where a test is made to determine if SpO₂ Signal OK Counter is greater than or equal to seven consecutive seconds. If not, the logic moves to block 382 where SpO₂ Slope is set to zero and the logic of FIG. 12 ends and processing returns to FIG. 8.

If however, SpO₂ Signal OK Counter is greater than or equal to seven consecutive seconds (yes in decision block 380), the logic moves to block 384 where SpO₂ Slope is set to the average of the last seven second-to-second SpO₂ changes. Next, logic is performed to ensure that the slope is within the allowable limits. If in decision block 386 it is determined that SpO₂ Slope is greater than SpO₂ Slope High Limit (e.g., a change of more than 5%), the logic moves to block 388 where SpO₂ Slope is set to SpO₂ Slope High limit (e.g., SpO₂ Slope is set to +5%). If it is determined in decision block 390 that SpO₂ Slope is less than SpO₂ Slope Low Limit, the logic moves to block 392 where SpO₂ Slope is set to SpO₂ Slope Low Limit (e.g., SpO₂ Slope is set to -5%). The logic of FIG. 12 then ends and processing returns to FIG. 8.

Returning to FIG. 8, after the slope has been calculated (block 268), the logic moves to block 270 where FiO₂ Max/Min timing is performed as illustrated in detail in FIG. 13 and described next.

The logic of FIG. 13 illustrates exemplary logic for performing FiO₂ Max/Min timing in accordance with the present invention. The algorithm monitors the actual value for FiO₂ Set by counting the time at the maximum and minimum FiO₂ limits. If FiO₂ has been continuously at the maximum limit longer than FiO₂ Max Alarm Interval, the user is alerted. The time in FiO₂ max and min is also used later for calculation of FiO₂ Base (FIG. 18).

The logic of FIG. 13 moves from a start block to decision block 400 where a test is made to determine if FiO₂ Set is equal to FiO₂ Min. If not, the logic moves to block 402 where FiO₂ Min Counter is set to zero. If so, the logic moves to block 404 where FiO₂ Min Counter is incremented. Next, the logic moves to decision block 406 where a test is made to determine if FiO₂ Set is equal to FiO₂ Max. If not, the logic moves to block 408 where FiO₂ Max Counter is set to zero and the logic of FIG. 13 ends and processing returns to FIG. 8.

If, however, FiO₂ Set is not equal to FiO₂ Max, the logic moves from decision block 406 to block 410 where FiO₂ Max Counter is incremented. The logic then moves to block 412 where the user is alerted if it (FiO₂ Max Counter) is greater than 60 seconds. It will be appreciated that the time may be set to some value other than 60 seconds in various embodiments. The logic of FIG. 13 then ends and processing returns to FIG. 8.

Returning to FIG. 8, after FiO₂ Max/Min timing has been performed, the logic moves to decision block 272 where a test is made to determine if closed-loop control is enabled. If so, the logic moves to block 273 where FiO₂ Set Determination is performed as illustrated in detail in FIG. 14 and described next.

The logic of FIG. 14 illustrates exemplary logic for performing FiO₂ Set Determination in accordance with the present invention. SpO₂ Read values are classified into SpO₂ levels: normoxemia, hyperoxemia and hypoxemia. The updated FiO₂ Set value is calculated in different ways according to the oxygenation range (SpO₂ level) that SpO₂ Read is currently in. The logic of FIG. 14 moves from a start block to decision block 450 where a test is made to determine the SpO₂ level. Appropriate processing is then performed based on the SpO₂ level. If the SpO₂ level indicates hypoxemia, the logic moves to block 452 where FiO₂ Set Determination in Hypoxemia is performed as illustrated in detail in FIG. 15 and described below. If the SpO₂ level indicates hyperoxemia, the logic moves to block 454 where FiO₂ Set Determination in Hyperoxemia is performed as illustrated in detail in FIG. 16 and described below. If the SpO₂ level indicates normoxemia, the logic moves to block 456 where FiO₂ Set Determination in Normoxemia is performed as illustrated in detail in FIG. 17 and described below.

FIG. 15 illustrates exemplary logic for performing FiO₂ Set Determination in Hypoxemia in accordance with the present invention. When hypoxemia occurs, the algorithm of the present invention determines an initial increase in FiO₂ Set of significant magnitude sufficient to offset the initial cascade effect of hypoxia as well as any lag time in changing the inspired O₂ concentration by the delivery mode. As soon as the SpO₂ Read value drops below the low limit of the target range set by the user and remains for the minimum required time (e.g., three seconds), the algorithm increases FiO₂ Set (occurring once for every time it drops to the hypoxemic range). Simultaneously, if the calculated SpO₂ slope is negative (trend is a decrease in SpO₂), FiO₂ Set is increased in direct proportion to the speed of change (e.g., every second). To prevent overshoot because of the system and intrinsic delays from the time inspired O₂ concentration changes until SpO₂ returns to normoxemia, FiO₂ Set is weaned down in steps proportional to the actual FiO₂ Set (e.g., every second) as soon as the SpO₂ shows signs of recovery (positive slope). Weaning (reduction) of the excess inspired oxygen concentration prevents arterial unnecessary supplemental oxygen exposure while oxygen saturation levels are in the normal range. FiO₂ is not weaned down below the basal level. Weaning is halted if the SpO₂ slope is flat or negative. If SpO₂ remains in the hypoxemia range and does not show signs of recovery (slope is flat or negative), successive increments of magnitude proportional to the difference between the target range and the SpO₂ Read are made. The intervals at which these steps occur vary in duration in inverse proportion to the degree of hypoxemia (a lower SpO₂ Read will cause larger increments at shorter intervals).

The logic of FIG. 15 moves from a start block to decision block 460 where a test is made to determine if conditions for

11

initial FiO₂ increase are present. In exemplary embodiments, conditions for initial FiO₂ increase when SpO₂ has just dropped below range are:

- SpO₂ signal lost and recovered in Hypoxemia
- OR
- SpO₂ in Hypoxemia 85-Low Limit and previously SpO₂ in Normoxemia
- OR
- SpO₂ in Hypoxemia 75–85% and previously SpO₂ in Normoxemia or SpO₂ in Hypoxemia 85-Low Limit
- OR
- SpO₂ in Hypoxemia less than 75% and previously SpO₂ in Normoxemia or SpO₂ in Hypoxemia 85-Low Limit or SpO₂ in Hypoxemia 75–85%.

If conditions for initial FiO₂ increase (such as those described above) are present, the logic moves to block 462 where FiO₂ Set is increased using the following equation:

$$\text{FiO}_2 \text{ Set} = \text{FiO}_2 \text{ Set} + 6.0 * (\text{SpO}_2 \text{ Low Limit} - \text{SpO}_2 \text{ Read}) * (\text{FiO}_2 \text{ Base} / 100) \quad (1)$$

Next, the logic moves to decision block 464 where a test is made to determine if the slope is negative. If so, the logic moves to block 466 where FiO₂ Set is increased in direct proportion to the speed of change using the following equation:

$$\text{FiO}_2 \text{ Set} = \text{FiO}_2 \text{ Set} + 3.0 * \text{absolute} (\text{SpO}_2 \text{ Slope}) * (\text{FiO}_2 \text{ Base} / 100) \quad (2)$$

The logic then moves to decision block 468 where a test is made to determine whether conditions for FiO₂ weaning are present. In exemplary embodiments, conditions for FiO₂ weaning when SpO₂ begins to recover include:

- SpO₂ Read > 75
- AND
- SpO₂ Slope > 0
- AND
- FiO₂ Set > FiO₂ Base
- AND
- SpO₂ Signal OK Counter > SpO₂ OK Time Min (e.g., five seconds).

If conditions for weaning are present, the logic moves to block 470 where FiO₂ Set is decreased using the following equation:

$$\text{FiO}_2 \text{ Set} = \text{FiO}_2 \text{ Set} - 6.0 * \text{absolute} (\text{SpO}_2 \text{ Slope}) * (\text{FiO}_2 \text{ Set} / 100) \quad (3)$$

Next, the logic moves to decision block 472 where a test is made to determine if FiO₂ Set is less than FiO₂ Base. If so, the logic moves to block 474 where FiO₂ Set is set to FiO₂ Base. The logic then moves to block 476 where Hypoxemia Adjust Interval Counter (in seconds) is incremented and Hypoxemia Adjust Interval is calculated using the following equation:

$$\text{Hypoxemia Adjust Interval} = \text{SpO}_2 \text{ Read} - 65 \quad (4)$$

The Hypoxemia Adjust Interval is limited to a specific range. The logic moves to decision block 478 where a test is made to determine if the Hypoxemia Adjust Interval is greater than the High Limit (SpO₂ Low Adjust Interval High Limit), for example, 40 seconds. If so, the logic moves to block 480 where the Hypoxemia Adjust Interval is set to the High Limit, e.g., 40 seconds. The logic proceeds to decision block 482 where a test is made to determine if the Hypox-

12

emia Adjust Interval is less than the Low Limit (SpO₂ Low Adjust Interval Low Limit), for example, 5 seconds. If so, the logic moves to block 484 where the Hypoxemia Adjust Interval is set to the Low Limit, e.g., five seconds.

Next, a determination must be made as to whether it is time to adjust. The logic moves to decision block 486 where a test is made to determine if SpO₂ Slope is negative or zero and Hypoxemia Adjust Interval Counter is greater than or equal to Hypoxemia Adjust Interval. If so, the logic moves to block 488 where Hypoxemia Adjust Interval Counter is reset to zero and FiO₂ Set is increased using the following equation:

$$\text{FiO}_2 \text{ Set} = \text{FiO}_2 \text{ Set} + 3.0 * (\text{SpO}_2 \text{ Low Limit} - \text{SpO}_2 \text{ Read}) * (\text{FiO}_2 \text{ Base} / 100) \quad (5)$$

The logic of FIG. 15 then ends and processing returns to FIG. 14.

FIG. 16 illustrates exemplary logic for performing FiO₂ Set Determination in Hyperoxemia in accordance with the present invention. When hyperoxemia occurs, the system determines an appropriate initial decrease of FiO₂ Set that is of significant magnitude. This reduction is smaller than that occurring initially with hypoxemia. As soon as SpO₂ Read exceeds the limit of the target range set by the user and remains for the minimum required time within each range (e.g., three seconds), the algorithm decreases FiO₂ Set (once each time it reaches the hyperoxemic range). If SpO₂ signal was lost (OUT) and when recovered shows values in hyperoxemia, the FiO₂ Set value is changed to the FiO₂ Set value that was last recorded when SpO₂ dropped out. The new FiO₂ Set value should not exceed the FiO₂ Base level. When SpO₂ Read values reach the hyperoxemic range, the algorithm allows for weaning of FiO₂ Set during a wean interval (e.g., 30 seconds) occurring every second only if the current FiO₂ Set value is above the FiO₂ Base level or the SpO₂ Slope is positive (more hyperoxemic). Under both circumstances the FiO₂ Set value is weaned down only to the FiO₂ Base level. Once SpO₂ Read values have been in the hyperoxemic range longer than the initial wean interval (e.g., 30 seconds), the current FiO₂ Set value is decreased in proportion to a positive SpO₂ Slope (every second, but smaller adjustments). FiO₂ Set value can be lowered below the FiO₂ Base level. After the initial wean interval (e.g., 30 seconds) has elapsed, FiO₂ Set value is decreased at steps of magnitude proportional to the difference between the hyperoxemic SpO₂ Read value and the target SpO₂ range and the FiO₂ Base level. These adjustments, however, are smaller than those observed during hypoxemia. The intervals at which these adjustments occur are in inverse proportion to the degree of hyperoxemia. Therefore, an SpO₂ reading average of 97% will result in a smaller reduction than a 99% reading and at longer intervals. These reductions can lower FiO₂ Set below FiO₂ Base level.

The logic of FIG. 16 moves from a start block to decision block 490 where a test is made to determine if conditions for initial FiO₂ decrease are present. In exemplary embodiments of the invention, conditions for initial FiO₂ decrease when SpO₂ has just crossed the high limit of the target range are:

- SpO₂ Hyperoxemia Counter = Min Time in Range (e.g., three seconds)
- AND
- SpO₂ previously in Normoxemia OR SpO₂ Previously in Hypoxemia
- AND
- FiO₂ Set > FiO₂ Base.

If conditions for initial FiO₂ decrease are present, the logic moves to block 492 where FiO₂ Set is decreased using the following equation:

$$\text{FiO}_2 \text{ Set} = \text{FiO}_2 \text{ Set} - 3.0 * (\text{SpO}_2 \text{ Read} - \text{SpO}_2 \text{ High Limit}) * (\text{FiO}_2 \text{ Base} / 100) \quad (6)$$

Next, the logic moves to decision block 494 where a test is made to determine if FiO₂ Set is less than FiO₂ Base. If so, the logic moves to block 496 where FiO₂ Set is set to FiO₂ Base. Next, the logic moves to decision block 498 where a test is made to determine if SpO₂ Signal was OUT and recovered in hyperoxemia. If so, the logic moves from decision block 498 to decision block 500 where a test is made to determine if FiO₂ Set is greater than FiO₂ Set Last Before Signal Lost. If the outcomes of decision blocks 498 and 500 are both true, the logic moves to block 502 where FiO₂ Set is set to FiO₂ Set Last Before Signal Lost. If the outcome of decision block 498 is true, the logic proceeds to decision block 504 where a test is made to determine if FiO₂ Set is greater than FiO₂ Base. If so, the logic moves to block 506 where FiO₂ Set is set to FiO₂ Base.

Regardless of the outcome of decision block 498, the logic proceeds to decision block 508 where a test is made to determine if SpO₂ Hyperoxemia Counter is less than or equal to Wean Interval (e.g., 30 seconds). If so, the logic moves to decision block 510 where a test is made to determine if FiO₂ Set is greater than FiO₂ Base. If so, the logic moves to block 512 where FiO₂ Set is decreased according to the following equation:

$$\text{FiO}_2 \text{ Set} = \text{FiO}_2 \text{ Set} - 6.0 * (\text{SpO}_2 \text{ Read} - \text{SpO}_2 \text{ High Limit}) * (\text{FiO}_2 \text{ Set} / 100) \quad (7)$$

The logic proceeds to decision block 514 where a test is made to determine if SpO₂ Slope is positive (e.g., greater than zero). If SpO₂ Slope is positive, the logic moves to block 516 where FiO₂ is decreased using the following equation:

$$\text{FiO}_2 \text{ Set} = \text{FiO}_2 \text{ Set} - 3.0 * \text{absolute} (\text{SpO}_2 \text{ Slope}) * (\text{FiO}_2 \text{ Set} / 100) \quad (8)$$

Regardless of the outcome of decision block 514, the logic proceeds to decision block 518 where a test is made to determine if FiO₂ Set is less than FiO₂ Base. If so, the logic moves to block 520 where FiO₂ Set is set to FiO₂ Base. Regardless of the outcome of decision blocks 508, 510, 514 and 518, the logic proceeds to decision block 522 where a test is made to determine if SpO₂ Hyperoxemia Counter is greater than Wean Interval (e.g., 30 seconds). If so, the logic moves to decision block 524 where a test is made to determine if SpO₂ Slope is positive. If so, the logic moves to block 526 where FiO₂ Set is decreased using the following equation:

$$\text{FiO}_2 \text{ Set} = \text{FiO}_2 \text{ Set} - \text{absolute} (\text{SpO}_2 \text{ Slope}) * (\text{FiO}_2 \text{ Base} / 100) \quad (9)$$

Regardless of the outcome of decision block 524, the logic proceeds to block 528 where Hyperoxemia Adjust Interval Counter is incremented and Hyperoxemia Adjust Interval is calculated using the following equation:

$$\text{Hyperoxemia Adjust Interval} = 40.0 - 3.0 * (\text{SpO}_2 \text{ Read} - \text{SpO}_2 \text{ High Limit}) \quad (10)$$

Hyperoxemia Adjust Interval is limited to a specific range. The logic proceeds to decision block 529 where a test is made to determine if Hyperoxemia Adjust Interval is greater than SpO₂ High Adjust Interval High Limit (e.g., 60 seconds). If so, the logic moves to block 530 where Hyper-

oxemia Adjust Interval is set to SpO₂ High Adjust Interval High Limit, (e.g., 60 seconds). Next, the logic moves to decision block 531 where a test is made to determine if Hyperoxemia Adjust Interval is less than SpO₂ High Adjust Interval Low Limit (e.g., 20 seconds). If so, the logic moves to block 532 where Hyperoxemia Adjust Interval is set to SpO₂ High Adjust Interval Low Limit (e.g., 20 seconds). The logic then moves to decision block 534 where a test is made to determine whether it is time to adjust (i.e., whether the Hyperoxemia Adjust Interval Counter is greater than or equal to Hyperoxemia Adjust Interval). If it is time to adjust, the logic moves to block 536 where SpO₂ High Adjust Level is calculated as the average of the SpO₂ over the Hyperoxemia Adjust Interval. Next, the logic moves to block 538 where Hyperoxemia Adjust Interval Counter is reset to zero and FiO₂ is decreased based on the following equation:

$$\text{FiO}_2 \text{ Set} = \text{FiO}_2 \text{ Set} - 2.0 * (\text{SpO}_2 \text{ High Adjust Level} - \text{SpO}_2 \text{ High Limit}) * (\text{FiO}_2 \text{ Base} / 100) \quad (11)$$

The logic of FIG. 16 then ends and processing returns to FIG. 14.

FIG. 17 illustrates exemplary logic for performing FiO₂ Set Determination in Normoxemia in accordance with the present invention. If the SpO₂ signal was lost (OUT) and when recovered it shows values in normoxemia and FiO₂ Set is greater than the FiO₂ Set value that was last recorded when SpO₂ dropped out, the FiO₂ Set value is changed to that recorded value. This new FiO₂ Set value should not exceed the FiO₂ Base level. When SpO₂ Read values reach the normoxemic range after recovering from hypoxemia while the current FiO₂ Set value is above the FiO₂ Set Base level and the SpO₂ Slope does not show a decrease (is not negative), the algorithm decreases the FiO₂ Set value (one time). The FiO₂ Set value is not weaned down below the FiO₂ Base level. When SpO₂ Read values fall in the lower half of the normoxemic range (between the low limit of the target range of normoxemia and the default mid-value SpO₂ Base) and it shows signs of worsening (negative SpO₂ Slope), the FiO₂ Set value is increased in proportion to SpO₂ slope and the FiO₂ Base level. This is done to avert any onset of hypoxemia. When SpO₂ Read values reach the normoxemic range, the algorithm allows for weaning of FiO₂ Set every second during a wean interval (e.g., 45 seconds). This weaning occurs if the current FiO₂ Set value is above the FiO₂ Base level and the SpO₂ Slope is positive (towards hyperoxemia). The reduction is proportional to the slope. If the current FiO₂ Set value is above the FiO₂ Base level but the SpO₂ Slope is flat, the reduction is proportional only to the actual FiO₂ Set value. Under both conditions, the FiO₂ Set value is not weaned down below the FiO₂ Base level.

Once SpO₂ read values have been in the normoxemic range longer than initial wean interval (e.g., 45 seconds) and the current FiO₂ Set value is greater than the FiO₂ Base level and there is a positive SpO₂ Slope, the FiO₂ Set value is decreased (every second) in proportion to the slope and actual FiO₂ Set value. FiO₂ Set value is not weaned down below the FiO₂ Base level. After the initial wean interval (e.g., 45 seconds) has elapsed and the FiO₂ Set value is less than the FiO₂ Base level and there is a negative SpO₂ Slope and the FiO₂ Set value is increased in proportion to the SpO₂ Slope and the current FiO₂ Set level. This increase cannot cause the FiO₂ Set level to be above the FiO₂ Base level.

Once SpO₂ Read values have been in the normoxemic range longer than the initial wean interval (e.g., 45 seconds) or previous SpO₂ level was hyperoxemia or normoxemia and SpO₂ was lost and recovered (even before the initial wean interval of 45 seconds in both cases) the algorithm

15

averages SpO₂ Read values. The duration of these averaging intervals is in proportion to the departure of SpO₂ Read from the mid-point of normoxemia (e.g., SpO₂ Base=94%). If the average SpO₂ adjust value exceeds the SpO₂ Base level (e.g., 94%) and FiO₂ Set value is greater than the FiO₂ Base level, FiO₂ Set value is decreased in proportion to the difference of averaged to base SpO₂ and FiO₂ Base level. If the averaged SpO₂ adjust value is below the SpO₂ Base level (e.g., 94%) and FiO₂ Set value is less than the FiO₂ Base level, FiO₂ Set value is increased in proportion to the difference of averaged to base SpO₂ and FiO₂ Base level. The magnitude of the FiO₂ Set change is larger when the average SpO₂ is above the mid SpO₂ Base and FiO₂ Set is above FiO₂ Base than when the average SpO₂ is below the mid SpO₂ Base and FiO₂ Set is below FiO₂ Base. The purpose of this difference is to allow lower O₂, provided that SpO₂ is within normoxemia.

The logic of FIG. 17 moves from a start block to decision block 540 where a test is made to determine if SpO₂ Signal was OUT and recovered in Normoxemia. If so, the logic moves to decision block 542 where a test is made to determine if FiO₂ Set is greater than FiO₂ Before Signal Lost. If so, the logic moves to block 544 where FiO₂ Set is set to FiO₂ Before Signal Lost. Regardless of the outcome of decision block 542, the logic proceeds to decision block 546 where a test is made to determine if FiO₂ Set is greater than FiO₂ Base. If so, the logic proceeds to block 548 where FiO₂ Set is set to FiO₂ Base. Regardless of the outcome of decision block 540, the logic proceeds to decision block 550 where a test is made to determine if conditions for initial FiO₂ decrease are present. In exemplary embodiments of the invention, conditions for initial FiO₂ decrease when SpO₂ just crossed the low limit of the target range recovering from hypoxemia are:

SpO₂ Normoxemia Counter=Min Time in Range (e.g., 3 seconds)

AND

SpO₂ was previously in Hypoxemia

AND

FiO₂ Set>FiO₂ Base

AND

SpO₂ Slope is flat (zero) or positive.

If conditions for initial FiO₂ decrease are present, the logic moves from decision block 550 to block 552 where FiO₂ Set is decreased using the following equation:

$$FiO_2 \text{ Set} = FiO_2 \text{ Set} - 6.0 * (SpO_2 \text{ Read} - SpO_2 \text{ Low Limit}) * (FiO_2 \text{ Set} / 100) \quad (12)$$

The logic then moves to decision block 554 where a test is made to determine if FiO₂ Set is less than FiO₂ Base. If so, the logic moves to block 556 where FiO₂ Set is set to FiO₂ Base. Regardless of the outcome of decision block 550, the logic proceeds to decision block 558 where a test is made to determine if SpO₂ Read is less than SpO₂ Base and SpO₂ Slope is negative. If so, the logic moves to block 560 where FiO₂ Set is increased according to the following equation:

$$FiO_2 \text{ Set} = FiO_2 \text{ Set} + 3.0 * \text{absolute} (SpO_2 \text{ Slope}) * (FiO_2 \text{ Base} / 100) \quad (13)$$

Regardless of the outcome of decision block 558, the logic proceeds to decision block 562 where a test is made to determine if SpO₂ Normoxemia Counter is less than or equal to Wean interval (e.g., 45 seconds) If so, the logic moves to decision block 564 where a test is made to determine if FiO₂ Set is greater than FiO₂ Base. If so, FiO₂ may be decreased

16

based on the slope. If SpO₂ Slope is positive (yes in decision block 566), the logic moves to block 568 where FiO₂ Set is decreased using the following equation:

$$FiO_2 \text{ Set} = FiO_2 \text{ Set} - 3.0 * \text{absolute} (SpO_2 \text{ Slope}) * (FiO_2 \text{ Set} / 100) \quad (14)$$

If SpO₂ Slope is flat, i.e., zero (yes in decision block 570), the logic moves to block 572 where FiO₂ is decreased using the following equation:

$$FiO_2 \text{ Set} = FiO_2 \text{ Set} - 3.0 * (FiO_2 \text{ Set} / 100) \quad (15)$$

The logic then moves to decision block 574 where a test is made to determine if FiO₂ Set is less than FiO₂ Base. If so, the logic moves to block 576 where FiO₂ Set is set to FiO₂ Base.

Regardless of the outcome of decision block 562, the logic proceeds to decision block 578 where a test is made to determine if SpO₂ Normoxemia Counter is greater than Wean Interval (e.g., 45 seconds). If so, the logic moves to decision block 580 where a test is made to determine if SpO₂ Slope is greater than zero and FiO₂ Set is greater than FiO₂ Base. If so, the logic moves to block 582 where FiO₂ Set is decreased using the following equation:

$$FiO_2 \text{ Set} = FiO_2 \text{ Set} - 3.0 * \text{absolute} (SpO_2 \text{ Slope}) * (FiO_2 \text{ Set} / 100) \quad (16)$$

The logic then moves to decision block 584 where a test is made to determine if FiO₂ Set is less than FiO₂ Base. If so, the logic moves to block 586 where FiO₂ Set is set to FiO₂ Base.

Regardless of the outcome of decision block 578, the logic proceeds to decision block 588 where a test is made to determine if SpO₂ Normoxemia Counter is greater than Wean Interval (e.g., 45 seconds). If so, the logic moves to decision block 590 where a test is made to determine if SpO₂ Slope is greater than zero and FiO₂ Set is less than FiO₂ Base. If so, the logic moves to block 592 where FiO₂ Set is increased using the following equation:

$$FiO_2 \text{ Set} = FiO_2 \text{ Set} + 3.0 * \text{absolute} (SpO_2 \text{ Slope}) * (FiO_2 \text{ Set} / 100) \quad (17)$$

The logic then moves to decision block 594 where a test is made to determine if FiO₂ Set is greater than FiO₂ Base. If so, the logic moves to block 596 where FiO₂ Set is set to FiO₂ Base.

Regardless of the outcome of decision block 588, the logic proceeds to decision block 598 where a test is made to determine if SpO₂ Counter is greater than Wean interval (e.g. 45 seconds) or if the previous level is Hyperoxemia or Normoxemia. If so, the logic moves to block 600 where Normoxemia Adjust Interval Counter is incremented and Normoxemia Adjust Level is calculated using the following equation:

$$\text{Normoxemia Adjust Interval} = 60.0 - 4.0 * \text{absolute} (SpO_2 \text{ Read} - SpO_2 \text{ Base}) \quad (18)$$

Normoxemia Adjust Interval is limited to a specific range. The logic moves to decision block 601 where a test is made to determine if Normoxemia Adjust Interval is greater than SpO₂ Normal Adjust Interval High Limit (e.g., 60 seconds). If so, the logic moves to block 602 where Normoxemia Adjust Interval is set to SpO₂ Normal Adjust Interval High Limit (e.g., 60 seconds). Next, the logic moves to decision block 604 where a test is made to determine if Normoxemia Adjust Interval is less than SpO₂ Normal Adjust Interval Low Limit (e.g., 20 seconds). If so, the logic moves to block 606 where Normoxemia Adjust Interval is set to SpO₂ Normal Adjust Interval Low Limit (e.g., 20 seconds). The logic then moves to decision block 608 where a test is made

17

to determine if it is time to adjust (i.e., Normoxemia Adjust Interval Counter is greater than or equal to Normoxemia Adjust Interval). If so, the logic moves to block 610 where SpO₂ Normoxemia Adjust Level is calculated as the average of the SpO₂ over the Normoxemia Interval. Next, the logic moves to decision block 612 where a test is made to determine if SpO₂ Adjust Level is greater than SpO₂ Base AND SpO₂ Slope is greater than or equal to zero AND FiO₂ Set is greater than FiO₂ Base. If so, the logic moves to block 614 where Normoxemia Adjust Interval Counter is reset to zero and FiO₂ Set is decreased using the following equation:

$$FiO_2 \text{ Set} = FiO_2 \text{ Set} - 2.0 * (SpO_2 \text{ Adjust Level} - SpO_2 \text{ Base}) * (FiO_2 \text{ Base} / 100) \quad (19)$$

The logic then moves to decision block 616 where a test is made to determine if SpO₂ Adjust Level is less than SpO₂ Base AND SpO₂ Slope is less than or equal to zero AND FiO₂ Set is less than FiO₂ Base. If so, the logic moves to block 618 where FiO₂ Set is increased using the following equation:

$$FiO_2 \text{ Set} = FiO_2 \text{ Set} + (SpO_2 \text{ Base} - SpO_2 \text{ Adjust Level}) * (FiO_2 \text{ Base} / 100) \quad (20)$$

The logic of FIG. 17 then ends and processing returns to FIG. 14.

Returning to FIG. 14, after the appropriate processing has been performed based on the SpO₂ level (hypoxemia in block 452, hyperoxemia in block 454 or normoxemia in block 456), the logic of FIG. 14 ends and processing returns to FIG. 8.

Returning to FIG. 8, if closed-loop control is not enabled (no in decision block 272), the logic moves to block 274 where FiO₂ Set is set to FiO₂ Backup. Next, the logic moves to block 276 where the user is alerted. Regardless of whether closed-loop control is enabled (decision block 272), the logic proceeds to decision block 278 where a test is made to determine if FiO₂ Base Calc is enabled. If so, the logic moves to block 280 where FiO₂ Base Determination is performed as shown in detail in FIG. 18 and described next.

FIG. 18 illustrates in detail exemplary logic for performing FiO₂ Base Determination in accordance with the present invention. When FiO₂ Base Calc is enabled, the algorithm automatically updates the basal oxygen when specific conditions are met as shown in FIG. 18. In exemplary embodiments, when FiO₂ Base Calc is enabled by the user, the algorithm averages five minutes (not necessarily continuous) worth of FiO₂ Set values occurring during specific conditions. The calculated average for FiO₂ Base is limited to +/-10% of the current FiO₂ Base value. The newly calculated FiO₂ Base value is averaged with the current FiO₂ Base value. The resulting value is the new FiO₂ Base value. The average interval duration is five minutes. This parameter can be modified according to the patient condition, either as a system default, by the user or automatically.

The logic of FIG. 18 moves from a start block to decision block 620 where a test is made to determine if there are conditions for FiO₂ Base. Exemplary conditions for inclusion of current FiO₂ Set value in FiO₂ base determination are:

- SpO₂ in Normoxemia AND SpO₂ Normoxemia Counter > SpO₂ Normoxemia Base Min (e.g., 30 sec)
- OR
- SpO₂ in Hyperoxemia AND FiO₂ Set = FiO₂ Min AND FiO₂ Min Counter > FiO₂ Base Min (e.g., 30 sec)
- OR

18

SpO₂ in Hypoxemia AND FiO₂ Set = FiO₂ Max AND FiO₂ Max Counter > FiO₂ Base Max (e.g., 60 sec)

OR

SpO₂ in Hyperoxemia AND FiO₂ Set < FiO₂ Base AND SpO₂ Hyperoxemia Counter > SpO₂ High wean interval (e.g., 30 sec)

OR

SpO₂ in Hypoxemia AND FiO₂ Set > FiO₂ Base AND SpO₂ Hypoxemia Counter > SpO₂ Low Alarm Limit (e.g., 60 sec).

In exemplary embodiments, at least one of the following conditions must be met to include a specific FiO₂ value in the calculation of FiO₂ base:

- (1) Current SpO₂ should be in normoxemia and SpO₂ has been in normoxemia for at last 30 seconds (base min);
- (2) Current SpO₂ should be in hyperoxemia and FiO₂ is at the FiO₂ minimum level and FiO₂ has been at the minimum FiO₂ level for at least 30 seconds (base min);
- (3) Current SpO₂ should be in hypoxemia and FiO₂ is at the FiO₂ max level and FiO₂ has been at the max FiO₂ level for at least 60 seconds (base max);
- (4) Current SpO₂ in Hyperoxemia and current FiO₂ is below FiO₂ base and SpO₂ has been in hyperoxemia longer than 30 seconds; or
- (5) Current SpO₂ in Hypoxemia and current FiO₂ is above FiO₂ Base and SpO₂ has been in hypoxemia longer than 60 seconds.

If conditions for FiO₂ base exist, the logic moves to block 622 where FiO₂ Base Counter is incremented using the following equation:

$$FiO_2 \text{ Base} = FiO_2 \text{ Base} + FiO_2 \text{ Set} \quad (21)$$

Regardless of the outcome of decision block 620, the logic proceeds to decision block 624 where a test is made to determine if there are 5 minutes (or whatever value is specified) of FiO₂ data. If so, the logic moves to block 626 where FiO₂ Base is averaged and set to be within the specified limit (e.g., +/-10%) of the current FiO₂ Base. FiO₂ Base Counter is reset to zero. The logic then moves to block 628 where the new and current FiO₂ Base values are averaged and set to be within the Max and Min settings. The logic of FIG. 18 then ends and processing returns to FIG. 8.

Returning to FIG. 8, regardless of whether FiO₂ Base Calc is enabled (decision block 278), the logic proceeds to block 282 where FiO₂ Set checking is performed as shown in detail in FIG. 19 and described next.

FIG. 19 illustrates exemplary logic for performing FiO₂ Set checking in accordance with the present invention. The logic of FIG. 19 ensures that FiO₂ Set is within the allowable range. If it is determined in decision block 630 that FiO₂ Set is greater than FiO₂ Max, FiO₂ Set is set to FiO₂ Max in block 632. If it is determined in decision block 634 that FiO₂ Set is less than FiO₂ Min, FiO₂ Set is set to FiO₂ Min in block 636. The logic of FIG. 19 then ends and processing returns to FIG. 8.

Returning to FIG. 8, the logic proceeds to block 284 where FiO₂ Base/Backup checking is performed as shown in detail in FIG. 20 and described next.

FIG. 20 illustrates exemplary logic for performing FiO₂ Base/Backup checking in accordance with the present invention. New FiO₂ Base and Backup values determined by the algorithm or set by the user are checked to ensure that they fall within the minimum and maximum ranges. If they don't, the user is alerted. In exemplary embodiments, if the value is not within acceptable limits, the value is set to an

appropriate value. The logic of FIG. 20 alerts the user (block 642) if it is determined that FiO₂ Base is greater than 5% or if FiO₂ Base is equal to FiO₂ Max as determined in decision block 640.

Similarly, if it is determined in decision block 644 that FiO₂ Backup is greater than 50% or FiO₂ Backup is equal to FiO₂ Max, the user is alerted in block 646. The logic of FIG. 20 then ends and processing returns to FIG. 8.

Returning to FIG. 8, the logic then proceeds to block 286 where FiO₂ Set Output Control to Mixer. Once the new FiO₂ value is confirmed, the updated FiO₂ Set value should be passed to the output routine that controls the air-oxygen blender. In exemplary embodiments, the output routine outputs a specific voltage to drive an external blender. In various embodiments, additional monitoring is provided to ensure correct mixing by monitoring data from a built-in FiO₂ analyzer. The logic of FIG. 8 then ends and processing returns to FIG. 6.

FIG. 21 illustrates an exemplary graphical user interface 700. The exemplary user interface 700 shown in FIG. 21 displays SpO₂ and FiO₂ parameters over a period of time. In an exemplary embodiment, the last five minutes and thirty minutes of data are displayed simultaneously. It will be appreciated that various other user displays are possible, for example in alternate embodiments, the user can select the time interval(s) for display data. The user interface also allows the user to interactively change various parameters. More specifically, the exemplary user interface 700 shown in FIG. 21 displays:

- the current SpO₂ value read by the oximeter 702;
- five minutes of tracing of SpO₂ at 60 second divisions 704;
- the current FiO₂ set at the blender 706;
- five minutes of tracing of FiO₂ Set values at 60 second divisions 708;
- 30 minutes of tracing of SpO₂ Read and FiO₂ Set values at five minute divisions 710;
- the SpO₂ level (e.g., 0=normoxemia, 1=hypoxemia and 2=hyperoxemia) 712;
- the previous SpO₂ level 714;
- the calculated SpO₂ Slope 716;
- the calculated SpO₂ trend based on SpO₂ slope magnitude 718;
- an SpO₂ high counter (hyperoxemia) 720;
- an SpO₂ normal counter (normoxemia) 722;
- an SpO₂ low counter (hypoxemia) 724;
- is an SpO₂ low counter for the range of 85%—the low SpO₂ limit 726;
- an SpO₂ low counter for the range of 75%—85% 728;
- an SpO₂ low counter for the range of less than 75% 730;
- an SpO₂ High Limit of the target range 732;
- an SpO₂ Low Limit of the target range 734;
- an SpO₂ signal OK counter 736;
- an SpO₂ signal OUT counter 738;
- a control button 744 which is the main switch to start closed loop adjustments (i.e., when OFF, FiO₂ is at backup level);

- a record button 746 which is used to record certain parameters (e.g., write to a file);
- an FiO₂ Base Cal switch 750 which is switched on and off to calculate the basal oxygen requirement;
- the FiO₂ Base value 752;
- a FiO₂ Base counter 754 which is used when FiO₂ Base Calc is enabled;
- an FiO₂ backup value 756; and
- an FiO₂ Minimum level 758.

As discussed earlier, the user can modify various parameters at any time. For example, in the exemplary embodiment shown in FIG. 21, the user can use the arrows to modify the values for the associated parameters.

Additional modifications and improvements of the present invention may also be apparent to those of ordinary skill in the art. Thus, the particular parts described and illustrated herein is intended to represent only one embodiment of the present invention, and is not intended to serve as limitations of alternative devices within the spirit and scope of the invention.

What is claimed is:

1. A computer-controlled system for automatically adjusting fractionally inspired oxygen delivery to a patient, said system comprising:

- a. a device for determining arterial hemoglobin oxygen saturation for the patient, wherein said device outputs a signal specifying said arterial hemoglobin oxygen saturation;
- b. a device for delivering the fractionally inspired oxygen to the patient; and
- c. a computer algorithm, wherein said computer algorithm determines an appropriate fractionally inspired oxygen value in response to the signal specifying said arterial hemoglobin oxygen saturation and communicates the appropriate fractionally inspired oxygen value to the device for delivering the fractionally inspired oxygen to the patient, wherein when the signal is unavailable after a predetermined wait time, the computer algorithm further includes a backup function to lock the fractionally inspired oxygen value at the higher of a backup level and a current inspired oxygen value until the signal is available.

2. The computer-controlled system according to claim 1, wherein the device for determining arterial hemoglobin oxygen saturation for the patient is a pulse oximeter.

3. The computer-controlled system according to claim 1, wherein the device for delivering the fractionally inspired oxygen to the patient is a mechanical ventilator.

4. The computer-controlled system according to claim 1, further comprising an alert device activated when an episode of hyperoxemia or hypoxemia occurs, when the episode lasts more than a predetermined period of time in spite that an adjustment of the fractional inspired oxygen value has been made, and the adjustment sets the fractional inspired oxygen value at a preset level.

5. The computer-controlled system according to claim 1, further comprising an alert device activated when the signal specifying said arterial hemoglobin oxygen saturation is lost.

专利名称(译)	用于闭环控制的吸入氧浓度的系统和方法		
公开(公告)号	US6671529	公开(公告)日	2003-12-30
申请号	US10/306643	申请日	2002-11-27
[标]申请(专利权)人(译)	CLAURE NELSON - [R BANCALARI EDUARDO ^ h		
申请(专利权)人(译)	CLAURE NELSON R. BANCALARI EDUARDO H.		
当前申请(专利权)人(译)	迈阿密大学		
[标]发明人	CLAURE NELSON R BANCALARI EDUARDO H		
发明人	CLAURE, NELSON R. BANCALARI, EDUARDO H.		
IPC分类号	A61M16/10 A61M16/00 A61M16/12 A61B5/00		
CPC分类号	A61M16/0051 A61M16/12 A61M2230/205 A61M16/024		
代理机构(译)	STETINA BRUNDA GARRED & BRUCKER		
审查员(译)	刨, KEVIN		
助理审查员(译)	拉玛纳, ANURADHA		
其他公开文献	US20030078480A1		
外部链接	Espacenet USPTO		

摘要(译)

公开了一种用于响应于接收动脉血红蛋白氧饱和度信号 (SpO₂) 而向患者输送分数吸入氧 (FiO₂) 的系统和方法。例如, 通过使用脉搏血氧计测量SpO₂。算法接收指示SpO₂的信号。该算法确定SpO₂处于正常血氧范围, 低氧血症范围或高氧血症范围。该算法还通过计算SpO₂中第二到第二变化的斜率来确定趋势。基于当前的SpO₂和趋势, 该算法确定患者的适当FiO₂, 并指示诸如机械呼吸机或空气氧气混合器的设备将适当的FiO₂输送给患者。系统使用默认值初始化各种参数, 但是用户 (例如, 护士) 也可以在任何时间更新设置。该系统还提供各种条件的警报, 例如标准脉搏血氧仪警报, 以及当发生高氧血症或低氧血症发作时的通知, 当它持续超过指定的时间段 (例如, 两分钟) 时, 尽管FiO₂调整以及调整时将FiO₂设置为特定水平。当SpO₂信号丢失时, 用户也会收到警报。

